



Project Number: U2716.0385.241

June 13, 2024

Sunmodo
14800 NE 65th Street
Vancouver, WA 98682

**REFERENCE: SunModo Sunturf Ground Mount A16 – Standard Panels
Ground Mount PV Array Installation**

To Whom It May Concern:

Per request of SunModo, we have been asked to prepare the structural design of a ground-mounted PV solar array system with several foundation options as shown in the attached calculations. The adopted building code in this jurisdiction is the 2021 Washington State Building Code (2021 IBC). Vector Structural Engineering requires that we review each site-specific install, and we are not liable for installs at site-specific locations we have not reviewed. This document does not address site-specific installations. The following design parameters are used in our analysis:

- Minimum Design Loads for Buildings and Other Structures (ASCE 7-22)
- Design wind speed for risk category I structures: 140 mph
- Wind exposure: C
- Ground snow load: 70 psf
- The ground screws and helical piers must be tested to 1.5 times uplift and 2.0 times lateral reactions found in the table below. A minimum of one ground screw or helical pier must be tested.

Load (ASD)	Value (lbs)	Factor of Safety	Test Value (lbs)
UPLIFT	2554	1.5	3831
LATERAL	1940	2	3880

Foundation concrete shall have a minimum compressive strength of 2500 psi at 28 days. Cement for all concrete shall be Type I or II with a water/cement ratio of 0.50. Maximum aggregate size shall be 3/4". No special inspection of concrete strength is required.

Footings are designed based on an allowable soil bearing pressure of 1500 psf an allowable skin friction of 250 psf, an allowable lateral bearing pressure of 150 pcf, and a coefficient of friction of 0.3. Vector Structural Engineering strongly recommends independent soils testing be performed by a licensed geotechnical engineer to verify the assumed soil parameters.

All ground mounts are to be installed per manufacturer’s recommendations. The use of solar panel support span tables provided by the manufacturer is allowed only where the site conditions and solar panel configuration match the description of the span tables. Electrical engineering is beyond our scope. All work performed must be in accordance with accepted industry-wide methods and applicable safety standards. Vector Structural Engineering assumes no responsibility for improper installation of the solar panels.

Very truly yours,

VECTOR STRUCTURAL ENGINEERING, LLC
Firm License: 2202

Wells Holmes, S.E.
License: 51006 - Expires: 10/06/2024
Project Engineer

Enclosures

WLH/reh

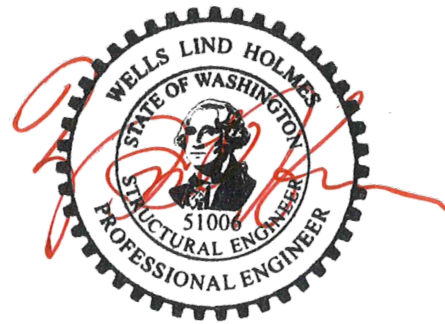

06/13/2024



JOB NO. U2716-0385-241
 PROJECT SUNMODO SUNTURF GROUND MOUNT A16
 SUBJECT ALL OPTIONS

651 W GALENA PARK BLVD. #101 (801) 990-1775
 DRAPER, UTAH 84020 (801) 990-1776 FAX

Vector Structural Engineering requires that we review each site-specific install, and we are not liable for installs at site-specific locations we have not reviewed. This document does not address site-specific installations.

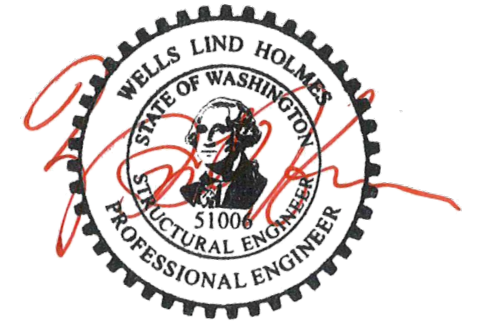

06/13/2024

NOTES:

1. SEE SUNMODO SHOP DRAWINGS FOR GROUND MOUNT MEMBER SIZES, GEOMETRY, AND POST SPACING

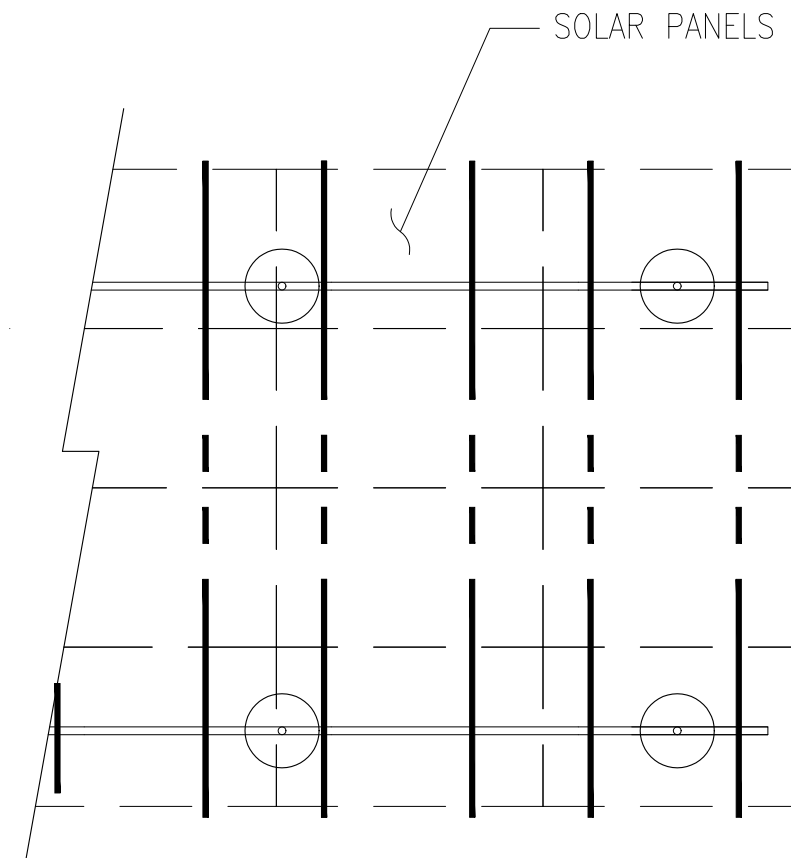
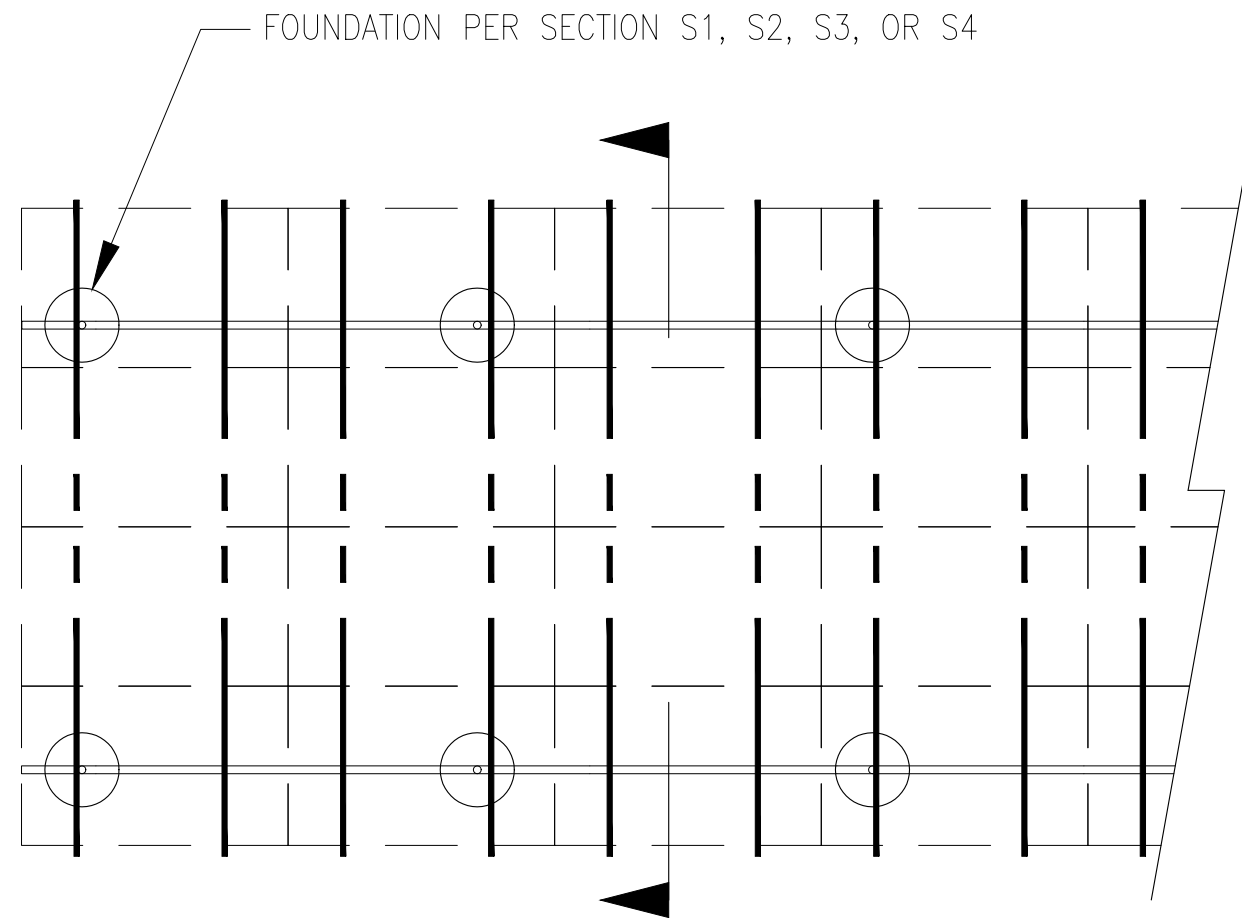

PV ARRAY PLAN

N.T.S.

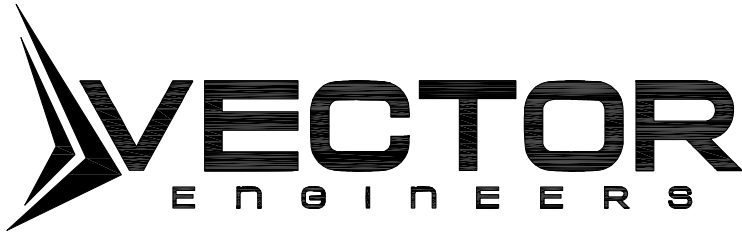

JOB NO. U2716-0385-241

PROJECT SUNMODO SUNTURF GROUND MOUNT A16

SUBJECT DRILLED PIER OPTION

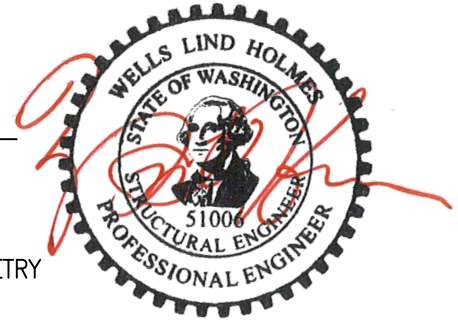

06/13/2024

NOTES:

- 1. SEE SUNMODO SHOP DRAWINGS FOR GROUND MOUNT MEMBER SIZES AND GEOMETRY

Vector Structural Engineering requires that we review each site-specific install, and we are not liable for installs at site-specific locations we have not reviewed. This document does not address site-specific installations.

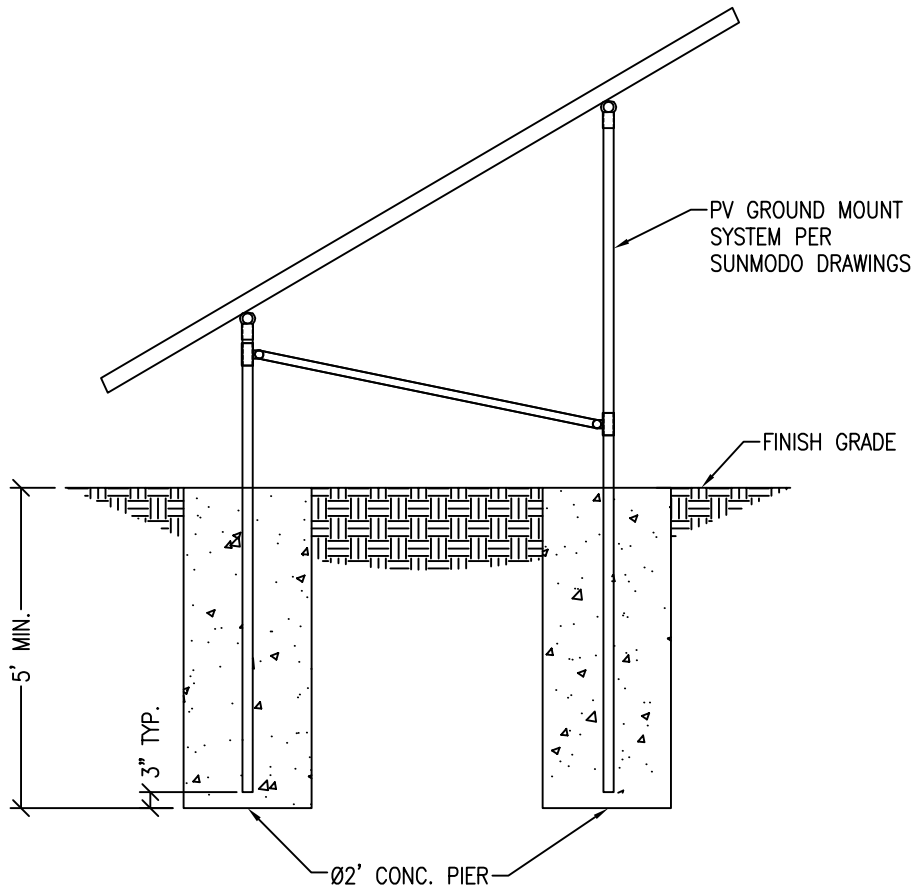

DRILLED PIER SECTION

NTS.

S1



JOB NO. U2716-0385-241

PROJECT SUNMODO SUNTURF GROUND MOUNT A16

SUBJECT HELICAL PIER OPTION

NOTES:

1. SEE SUNMODOD SHOP DRAWINGS FOR GROUND MOUNT MEMBER SIZES AND GEOMETRY
2. A MINIMUM OF (1) HELICAL PIER SHALL BE LOAD TESTED PER THE TEST LOADS LISTED ON THE COVER PAGE OF THIS LETTER. FAILURE CRITERIA IS AS FOLLOWS:
 - 2.1. LATERAL DEFLECTION OF 1" MEASURED AT GRADE UNDER LATERAL LOAD
 - 2.2. VERTICAL DEFLECTION OF 1/2" UNDER AXIAL LOAD
3. LOAD TESTS SHALL BE PERFORMED BY A LICENSED CONTRACTOR AS APPROVED BY THE AHJ

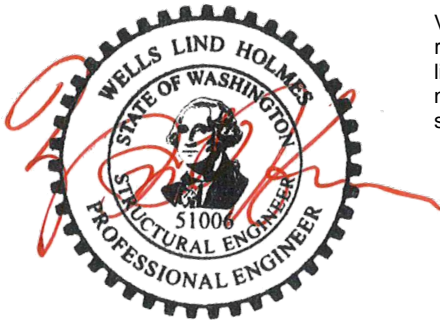

06/13/2024

Vector Structural Engineering requires that we review each site-specific install, and we are not liable for installs at site-specific locations we have not reviewed. This document does not address site-specific installations.

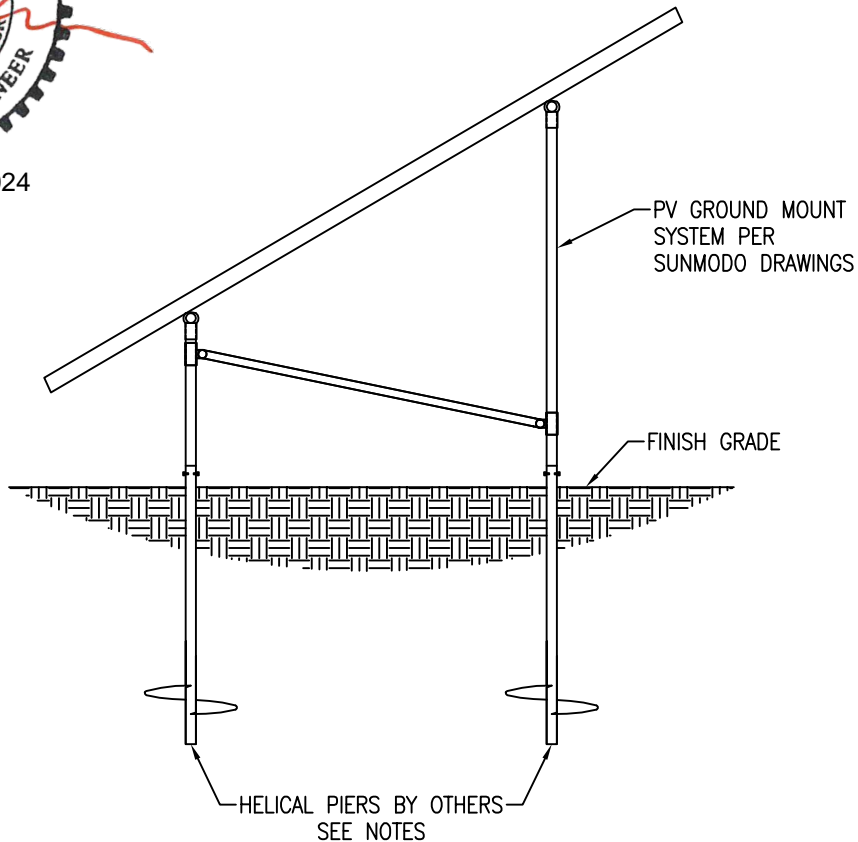

HELICAL PIER SECTION

NTS.



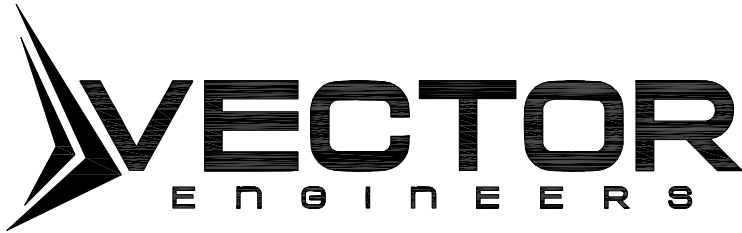

JOB NO. U2716-0385-241

PROJECT SUNMODO SUNTURF GROUND MOUNT A16

SUBJECT GROUND SCREW OPTION

NOTES:

1. SEE SUNMODOD SHOP DRAWINGS FOR GROUND MOUNT MEMBER SIZES AND GEOMETRY
2. A MINIMUM OF (1) HELICAL PIER SHALL BE LOAD TESTED PER THE TEST LOADS LISTED ON THE COVER PAGE OF THIS LETTER. FAILURE CRITERIA IS AS FOLLOWS:
 - 2.1. LATERAL DEFLECTION OF 1" MEASURED AT GRADE UNDER LATERAL LOAD
 - 2.2. VERTICAL DEFLECTION OF 1/2" UNDER AXIAL LOAD
3. LOAD TESTS SHALL BE PERFORMED BY A LICENSED CONTRACTOR AS APPROVED BY THE AHJ

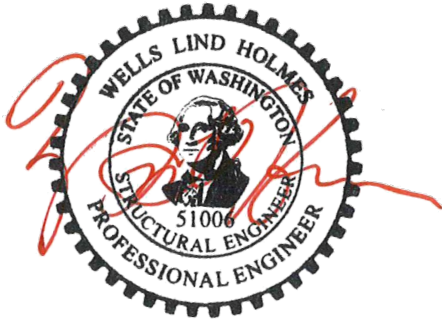

06/13/2024

Vector Structural Engineering requires that we review each site-specific install, and we are not liable for installs at site-specific locations we have not reviewed. This document does not address site-specific installations.

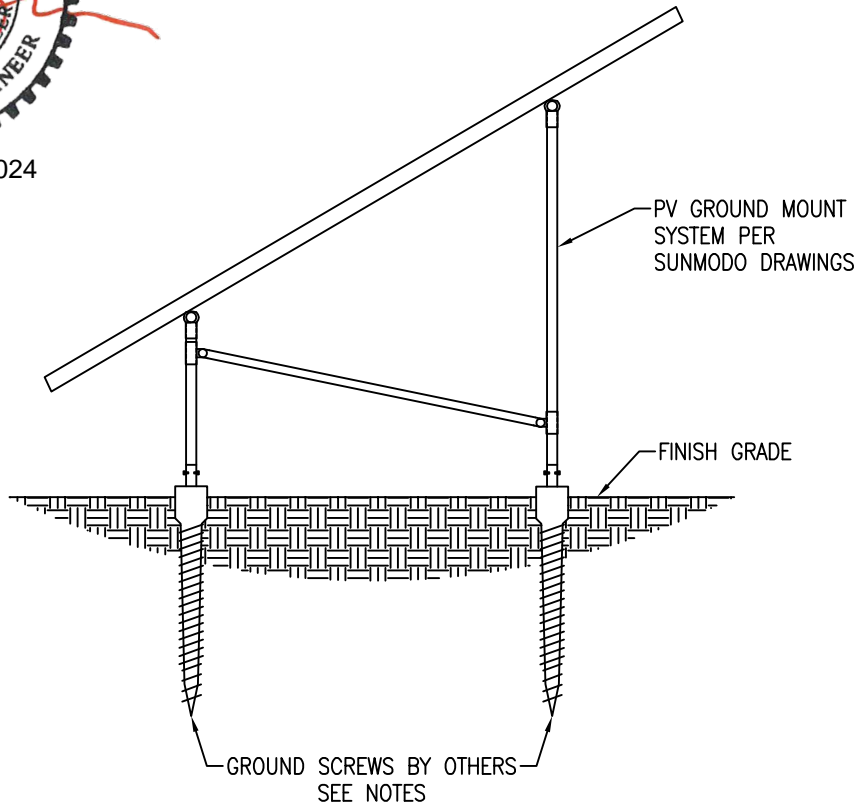

GROUND SCREW SECTION

NTS.



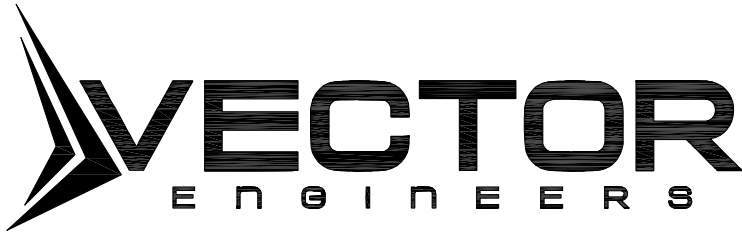

JOB NO. U2716-0385-241

PROJECT SUNMODO SUNTURF GROUND MOUNT A16

SUBJECT BALLAST BLOCK OPTION

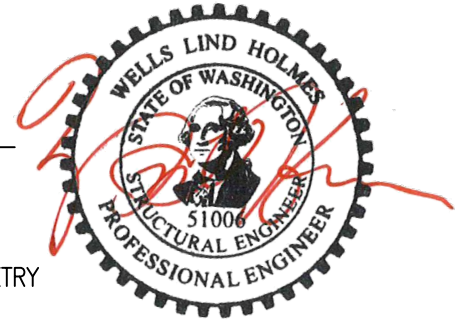

06/13/2024

NOTES:

- 1. SEE SUNMODO SHOP DRAWINGS FOR GROUND MOUNT MEMBER SIZES AND GEOMETRY

Vector Structural Engineering requires that we review each site-specific install, and we are not liable for installs at site-specific locations we have not reviewed. This document does not address site-specific installations.

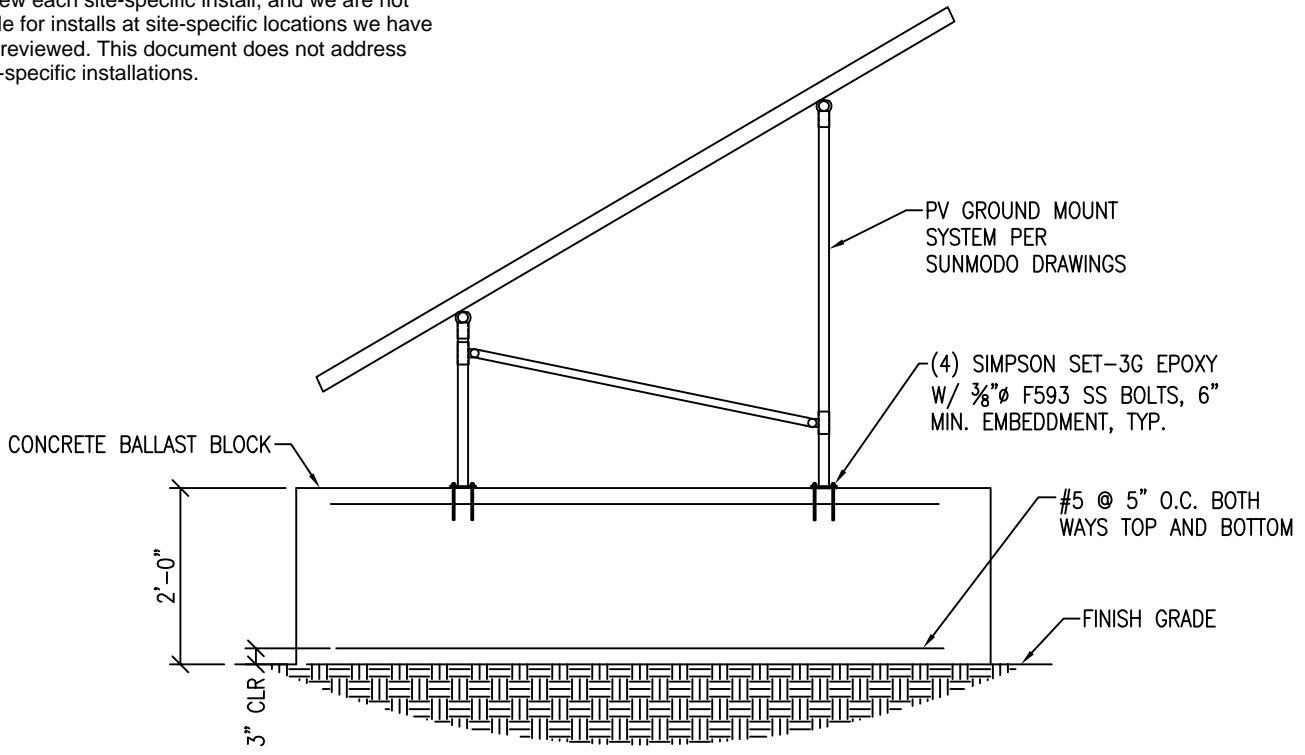

SECTION VIEW

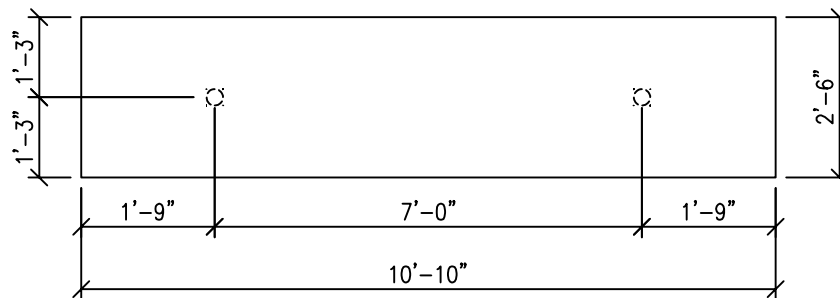

PLAN VIEW

BALLAST BLOCK SECTION

NTS.





PROJECT: Sunturf Package A16 Ground Mount

SNOW LOADS

Calculations Per:	ASCE 7-22	
Snow Ground Load, p_g [psf]:	70.0	(Section 7.2)
Risk Category:	I	(Table 1.5-1)
Terrain Category:	C	(Section 26.7)
Exposure of Roof:	Fully Exposed	(Table 7-2)
Exposure Factor, C_e :	0.9	(Table 7-2)
Thermal Factor, C_t :	1.2	(Table 7-3)
Flat Roof Snow Load, p_f [psf]:	53	(Equation 7.3-1)
Min. Roof Snow Load, p_m [psf]:	25	(Section 7.3.3)
Panel Slope from Horizontal [°]:	20.0	
Unobstructed Slippery Surface?	Yes	(Section 7.4)
Slope Factor Figure:	Figure 7-2c	(Section 7.4)
Roof Slope Factor, C_s :	0.64	
Sloped Roof Snow Load, p_s [psf]:	34	(Equation 7.4-1)
Array Width [ft]	11.0	
Required Leading Edge Height [ft]	3.7	
Leading Edge Height [ft]	3.0	
Design Snow Load, S [psf]:	53	(1.0 Snow)



PROJECT: Sunturf Package A16 Ground Mount

WIND PRESSURES

Calculations per:	ASCE 7-22	
Design Wind Speed, V [mph]:	140	
Risk Category:	I	(Table 1.5-1)
Exposure Category:	C	(Section 26.7)
Elevation [ft]:	-156.2	
Ground Elevation Factor, K_e :		(Not applicable)
α :	9.8	(Table 26.11-1)
z_g [ft]:	2460	(Table 26.11-1)
Velocity Pressure Exposure Coefficient, K_h :	0.85	(Table 26.10-1)
Topographic Factor, K_{ht} :	1.0	(Section 26.8)
Wind Directionality Factor, K_d :	0.85	(Table 26.6-1)
Internal Pressure Coefficient, GC_{pi} :	0.00	(Figure 26.13-1)
Velocity Pressure, q_h [psf]:	42.71	(Equation 26.10-1)
Gust Effect Factor, G:	0.85	(Section 26.11.4)
Panel Slope [degrees]:	20.0	
Wind Flow:	Clear	
Roof Configuration:	Monoslope	

Wind Pressures in Transverse (N-S) Direction

Net Pressure Coefficients per Figure 27.3-4

Clear Wind Flow	C_{NW}	C_{NL}
Case 1 ($\gamma = 0^\circ$, Load Case A)	-1.3	-1.5
Case 2 ($\gamma = 0^\circ$, Load Case B)	-2.2	-0.2
Case 3 ($\gamma = 180^\circ$, Load Case A)	1.6	1.7
Case 4 ($\gamma = 180^\circ$, Load Case B)	2.1	0.7

Design Wind Pressures per Equation 27.3-2 [psf]

Clear Wind Flow	$k_d q_h GC_{NW}$	$k_d q_h GC_{NL}$
Case 1 ($\gamma = 0^\circ$, Load Case A)	-40.1	-46.3
Case 2 ($\gamma = 0^\circ$, Load Case B)	-67.9	-6.2
Case 3 ($\gamma = 180^\circ$, Load Case A)	49.4	52.5
Case 4 ($\gamma = 180^\circ$, Load Case B)	64.8	21.6
Case 5 ($\gamma = 0^\circ$, 16 psf Min. Horiz.)	-16.0	-16.0
Case 6 ($\gamma = 180^\circ$, 16 psf Min. Horiz.)	16.0	16.0



PROJECT: Sunturf Package A16 Ground Mount

SNOW LOADS

Calculations Per:	ASCE 7-22	
Snow Ground Load, p_g [psf]:	70.0	(Section 7.2)
Risk Category:	I	(Table 1.5-1)
Terrain Category:	C	(Section 26.7)
Exposure of Roof:	Fully Exposed	(Table 7-2)
Exposure Factor, C_e :	0.9	(Table 7-2)
Thermal Factor, C_t :	1.2	(Table 7-3)
Flat Roof Snow Load, p_f [psf]:	53	(Equation 7.3-1)
Min. Roof Snow Load, p_m [psf]:	25	(Section 7.3.3)
Panel Slope from Horizontal [°]:	35.0	
Unobstructed Slippery Surface?	Yes	(Section 7.4)
Slope Factor Figure:	Figure 7-2c	(Section 7.4)
Roof Slope Factor, C_s :	0.64	
Sloped Roof Snow Load, p_s [psf]:	34	(Equation 7.4-1)
Array Width [ft]	15.0	
Required Leading Edge Height [ft]	3.9	
Leading Edge Height [ft]	3.0	
Design Snow Load, S [psf]:	53	(1.0 Snow)



PROJECT: Sunturf Package A16 Ground Mount

WIND PRESSURES

Calculations per:	ASCE 7-22	
Design Wind Speed, V [mph]:	140	
Risk Category:	I	(Table 1.5-1)
Exposure Category:	C	(Section 26.7)
Elevation [ft]:	-156.2	
Ground Elevation Factor, K_e :		(Not applicable)
α :	9.8	(Table 26.11-1)
z_g [ft]:	2460	(Table 26.11-1)
Velocity Pressure Exposure Coefficient, K_h :	0.85	(Table 26.10-1)
Topographic Factor, K_{ht} :	1.0	(Section 26.8)
Wind Directionality Factor, K_d :	0.85	(Table 26.6-1)
Internal Pressure Coefficient, GC_{pi} :	0.00	(Figure 26.13-1)
Velocity Pressure, q_h [psf]:	42.71	(Equation 26.10-1)
Gust Effect Factor, G:	0.85	(Section 26.11.4)
Panel Slope [degrees]:	35.0	
Wind Flow:	Clear	
Roof Configuration:	Monoslope	

Wind Pressures in Transverse (N-S) Direction

Net Pressure Coefficients per Figure 27.3-4

Clear Wind Flow	C_{NW}	C_{NL}
Case 1 ($\gamma = 0^\circ$, Load Case A)	-1.8	-1.8
Case 2 ($\gamma = 0^\circ$, Load Case B)	-2.4	-0.6
Case 3 ($\gamma = 180^\circ$, Load Case A)	2.1	2.1
Case 4 ($\gamma = 180^\circ$, Load Case B)	2.7	1.1

Design Wind Pressures per Equation 27.3-2 [psf]

Clear Wind Flow	$k_d q_h GC_{NW}$	$k_d q_h GC_{NL}$
Case 1 ($\gamma = 0^\circ$, Load Case A)	-55.5	-55.5
Case 2 ($\gamma = 0^\circ$, Load Case B)	-74.1	-18.5
Case 3 ($\gamma = 180^\circ$, Load Case A)	64.8	64.8
Case 4 ($\gamma = 180^\circ$, Load Case B)	83.3	33.9
Case 5 ($\gamma = 0^\circ$, 16 psf Min. Horiz.)	-16.0	-16.0
Case 6 ($\gamma = 180^\circ$, 16 psf Min. Horiz.)	16.0	16.0



JOB NO.: U2716.0385.241

PROJECT: Sunturf Package A16 Ground Mount

SNOW LOADS

Framing Analysis

SP - 20 deg

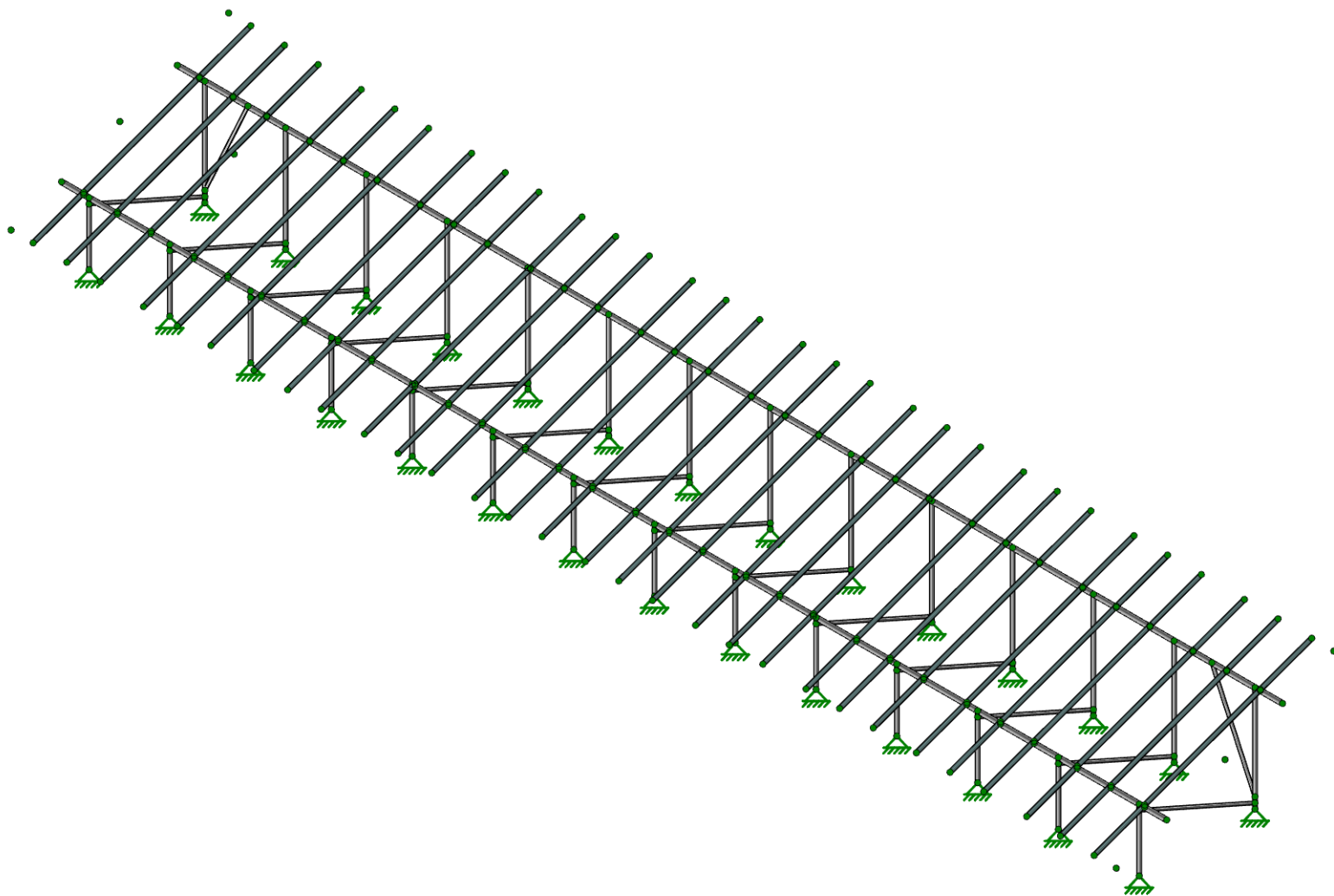
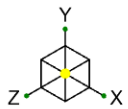

Vector Structural Engineering
CJT
U2716.0385.241

A16 Standard Panels - 20 Degree Tilt

SK-1
Mar 20, 2024
Sunturf A16 - SP - 20deg.r3d

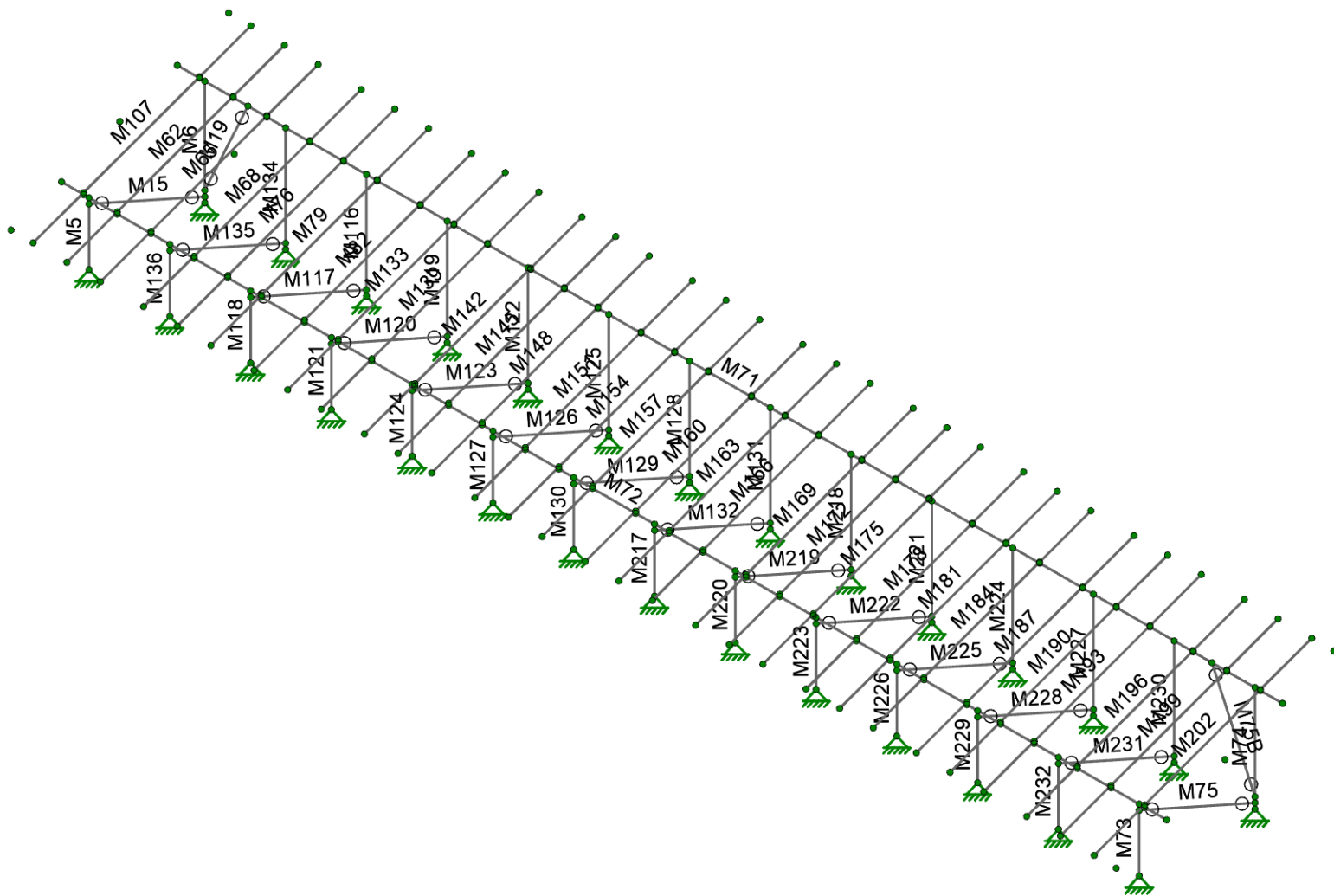
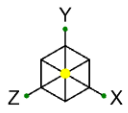

Vector Structural Engineering
CJT
U2716.0385.241

A16 Standard Panels - 20 Degree Tilt

SK-2
Mar 20, 2024
Sunturf A16 - SP - 20deg.r3d

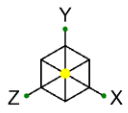

Section Sets

- █ Post
- █ Cross Beam
- █ Diagonal Brace
- █ RIGID
- █ AL Rails

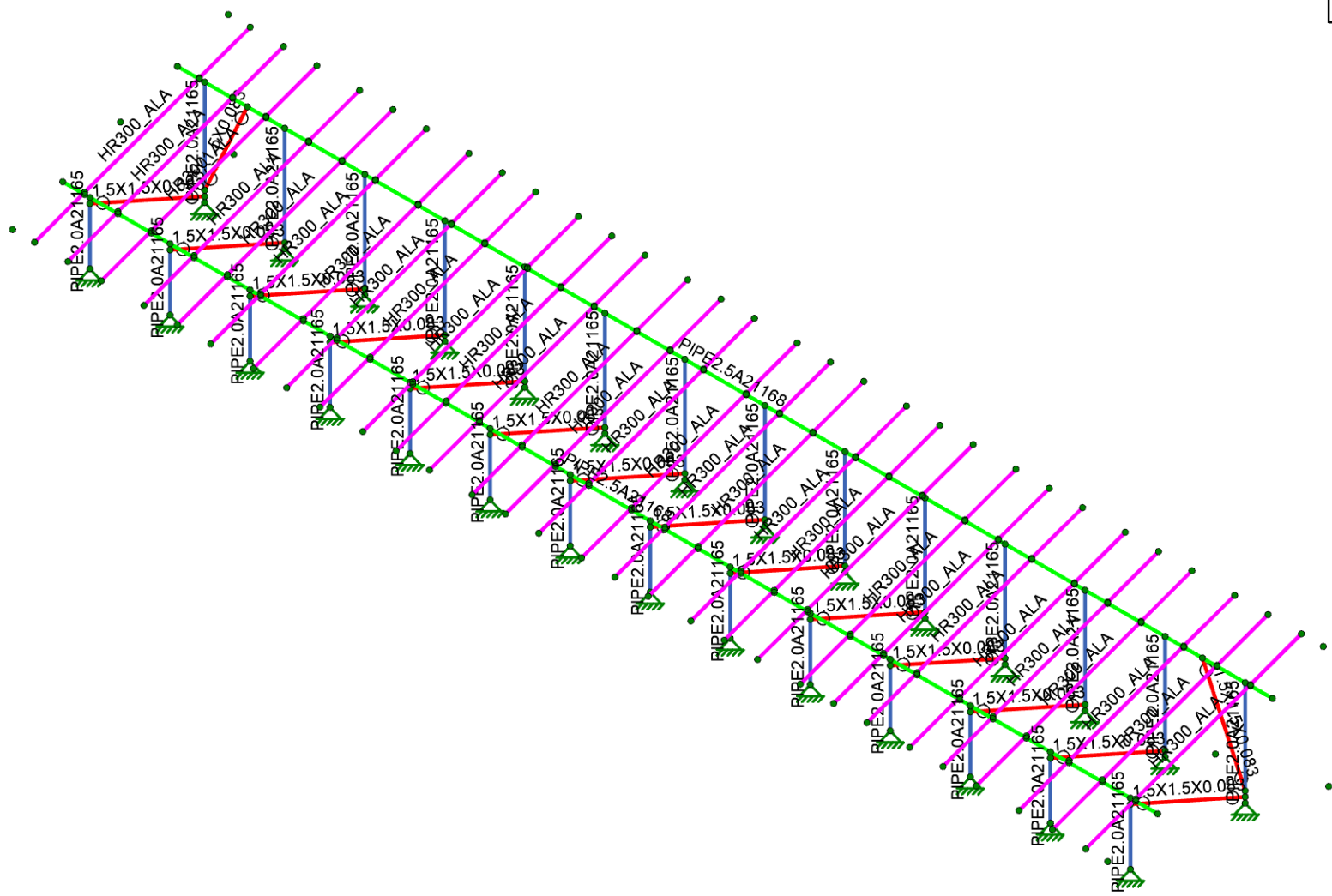

Vector Structural Engineering
 CJT
 U2716.0385.241

A16 Standard Panels - 20 Degree Tilt

SK-3
 Mar 20, 2024
 Sunturf A16 - SP - 20deg.r3d

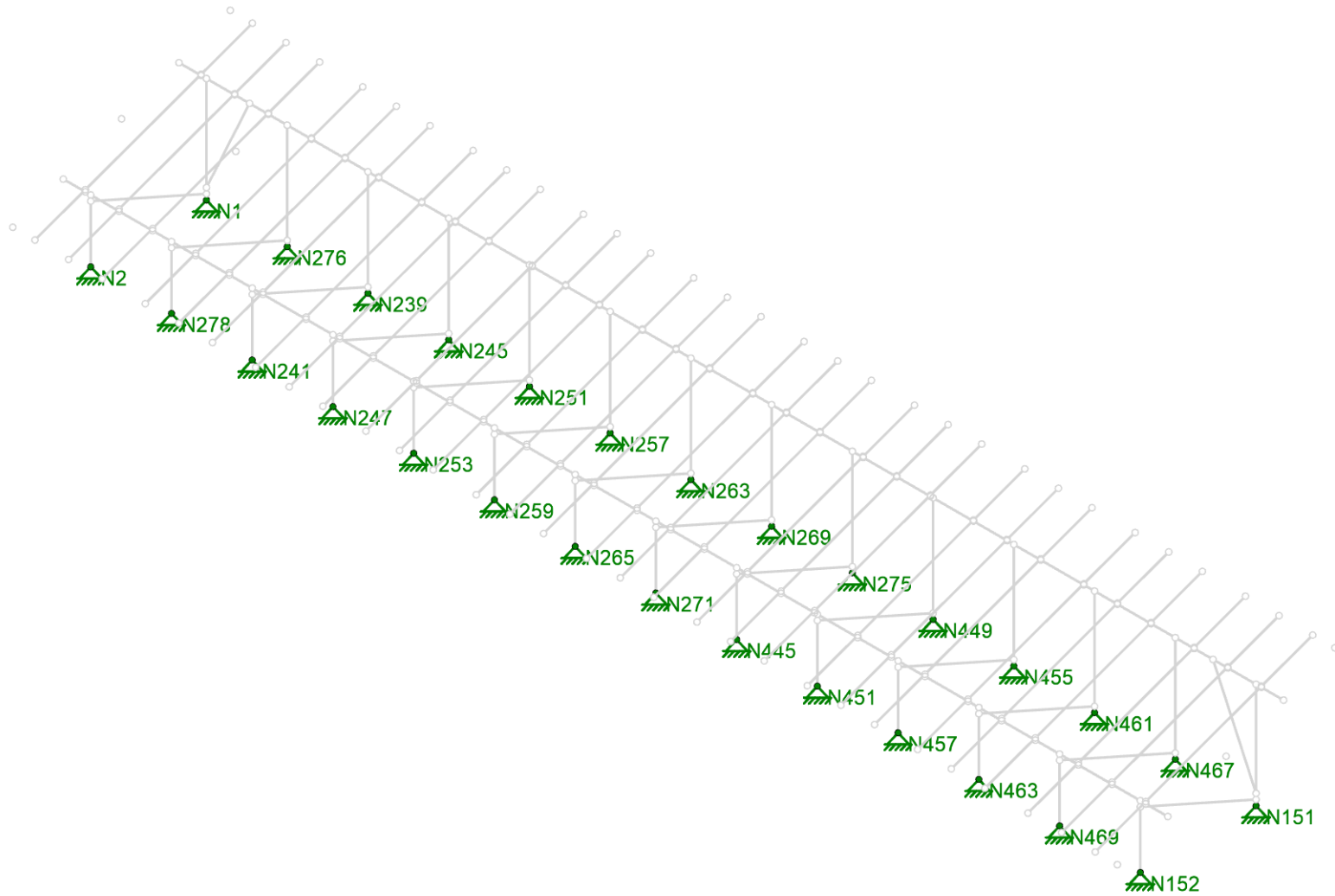
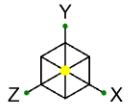

Vector Structural Engineering
CJT
U2716.0385.241

A16 Standard Panels - 20 Degree Tilt

SK-4
Mar 20, 2024
Sunturf A16 - SP - 20deg.r3d

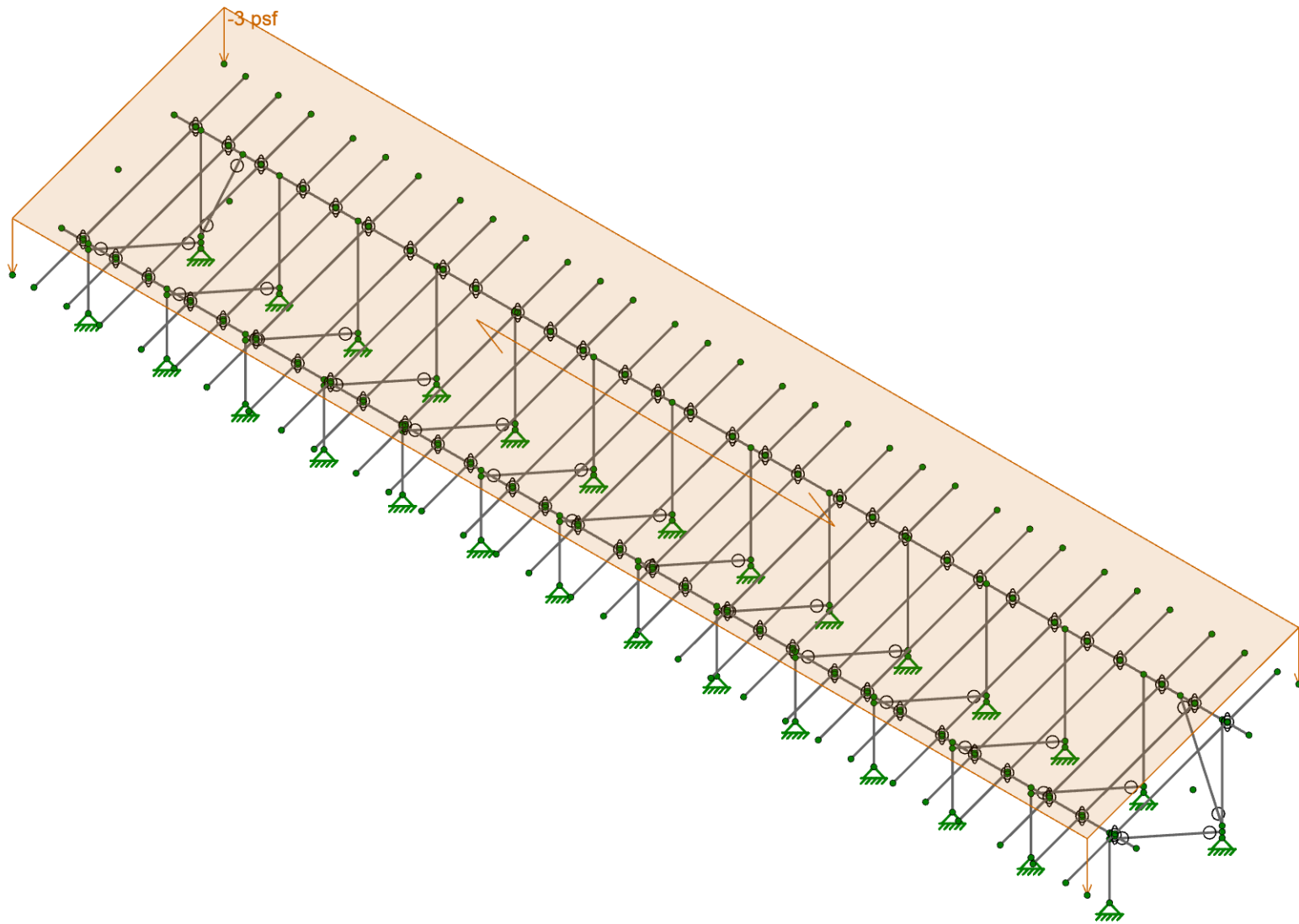
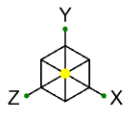

Loads: BLC 2, Solar Panel Weight



Vector Structural Engineering
CJT
U2716.0385.241

A16 Standard Panels - 20 Degree Tilt

SK-5
Mar 20, 2024
Sunturf A16 - SP - 20deg.r3d

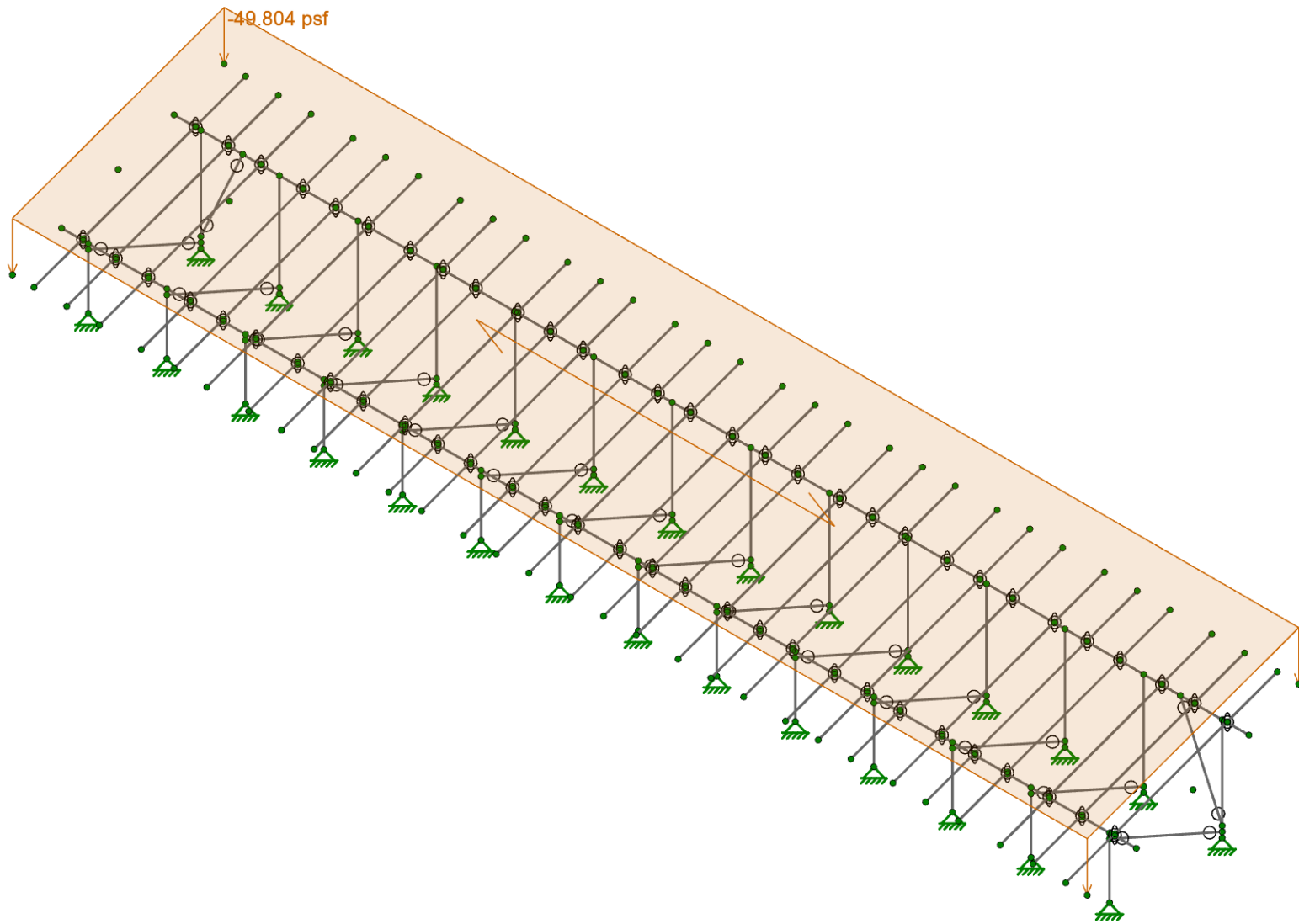
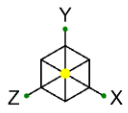

Loads: BLC 3, Roof Live/Snow



Vector Structural Engineering
CJT
U2716.0385.241

A16 Standard Panels - 20 Degree Tilt

SK-6
Mar 20, 2024
Sunturf A16 - SP - 20deg.r3d

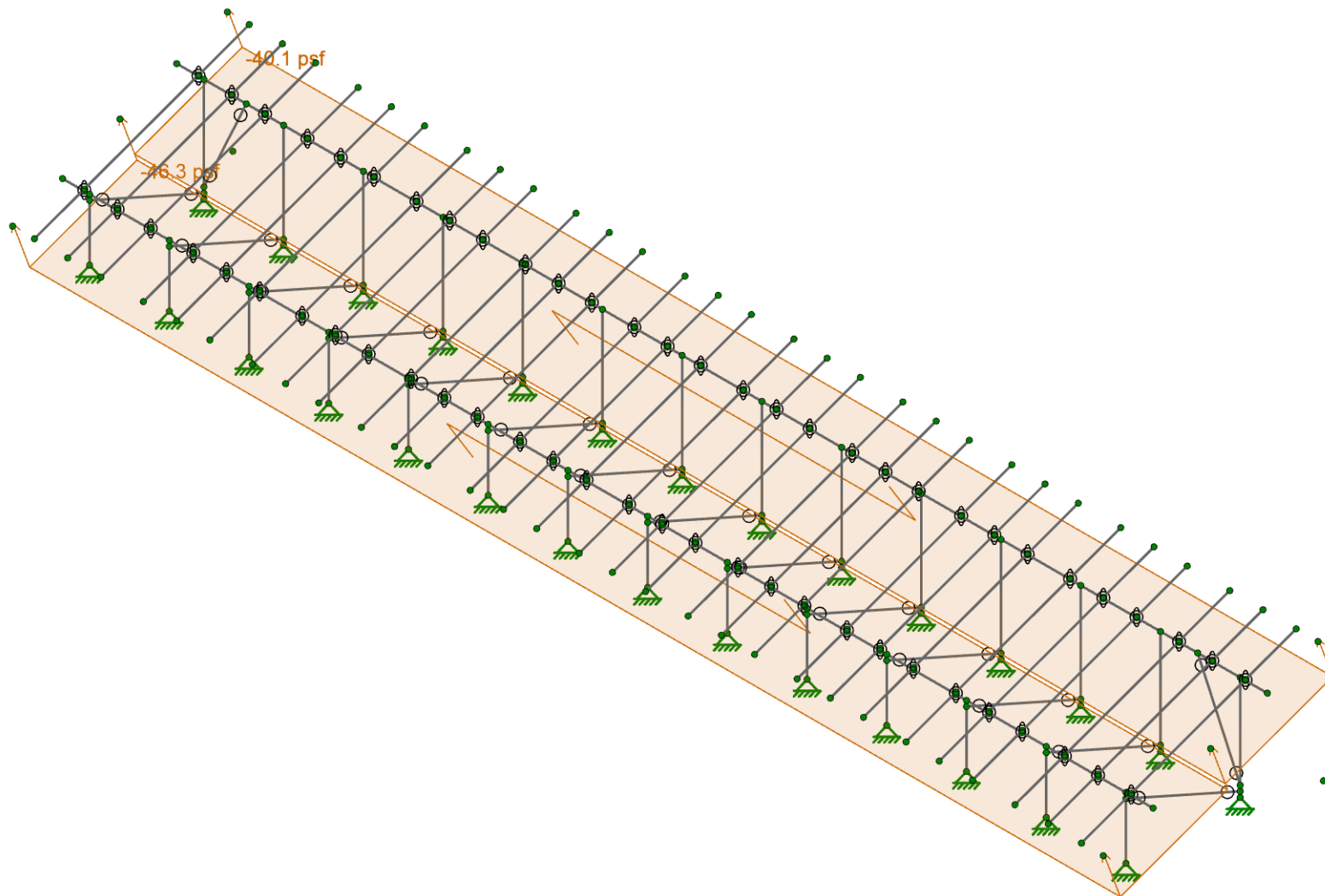
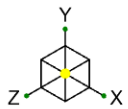

Loads: BLC 4, Wind A 0 deg



Vector Structural Engineering
CJT
U2716.0385.241

A16 Standard Panels - 20 Degree Tilt

SK-7
Mar 20, 2024
Sunturf A16 - SP - 20deg.r3d

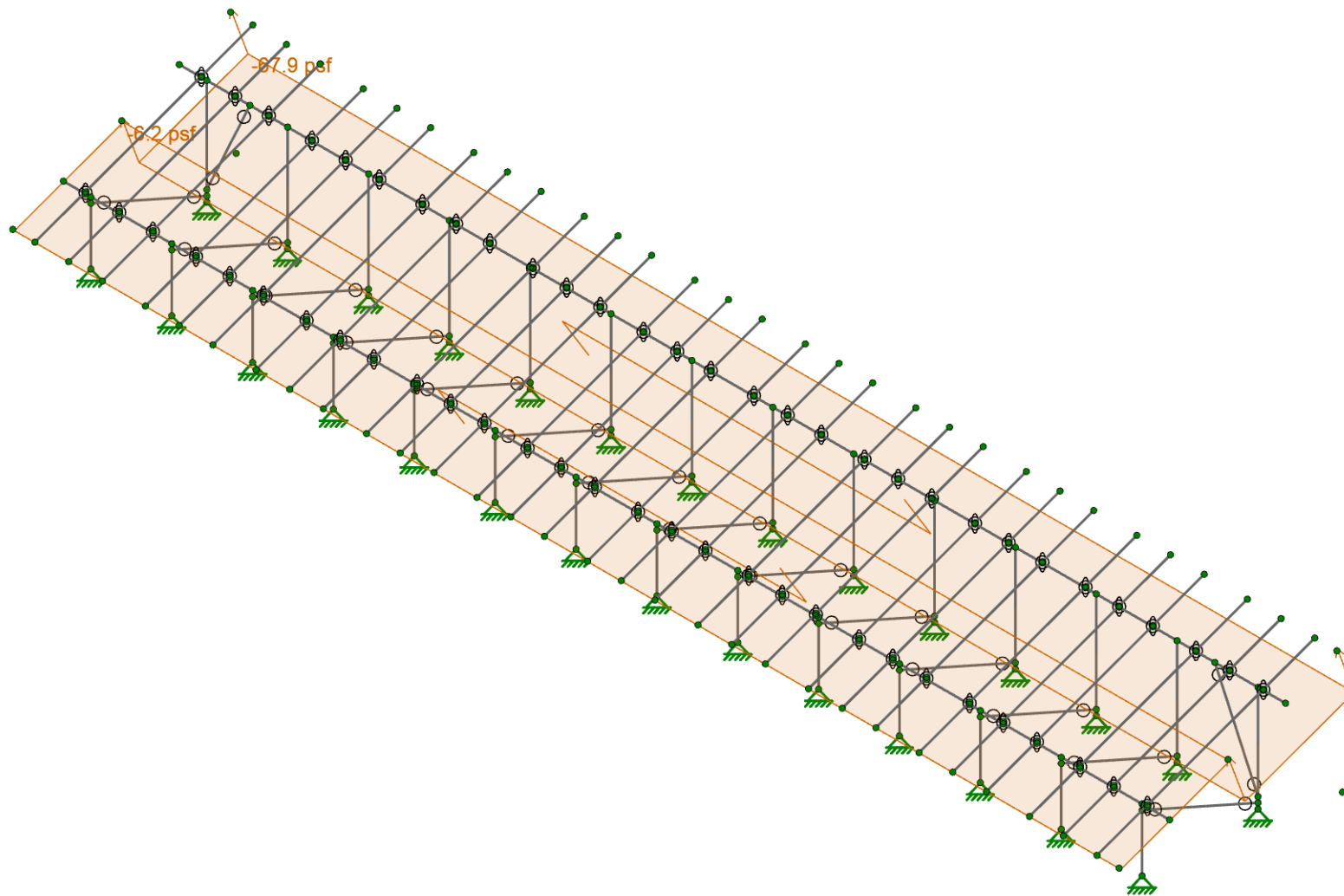
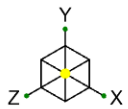

Loads: BLC 5, Wind B 0 deg



Vector Structural Engineering
CJT
U2716.0385.241

A16 Standard Panels - 20 Degree Tilt

SK-8
Mar 20, 2024
Sunturf A16 - SP - 20deg.r3d

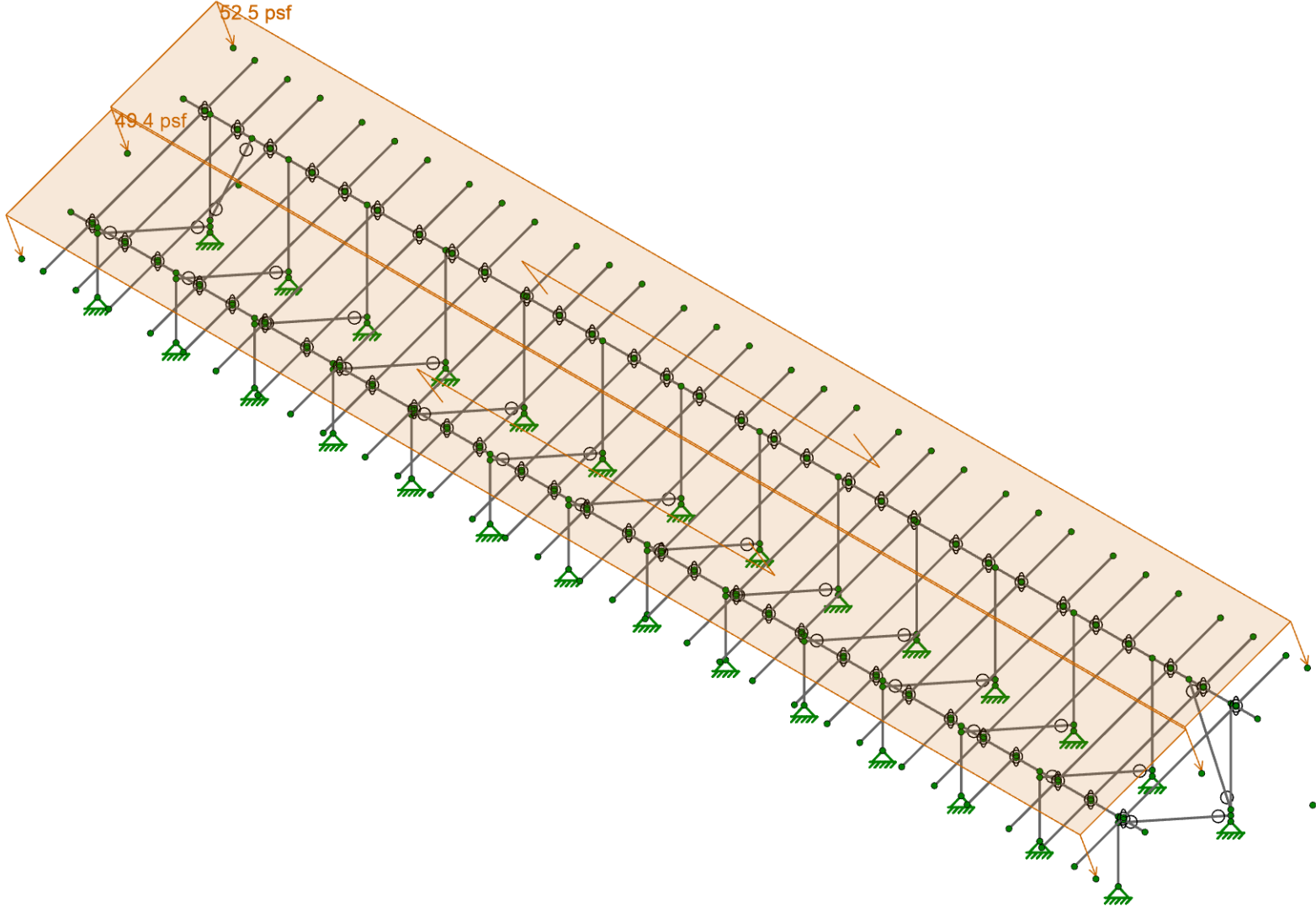
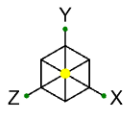

Loads: BLC 6, Wind A 180 deg

	Vector Structural Engineering
	CJT
	U2716.0385.241

A16 Standard Panels - 20 Degree Tilt

SK-9
Mar 20, 2024
Sunturf A16 - SP - 20deg.r3d

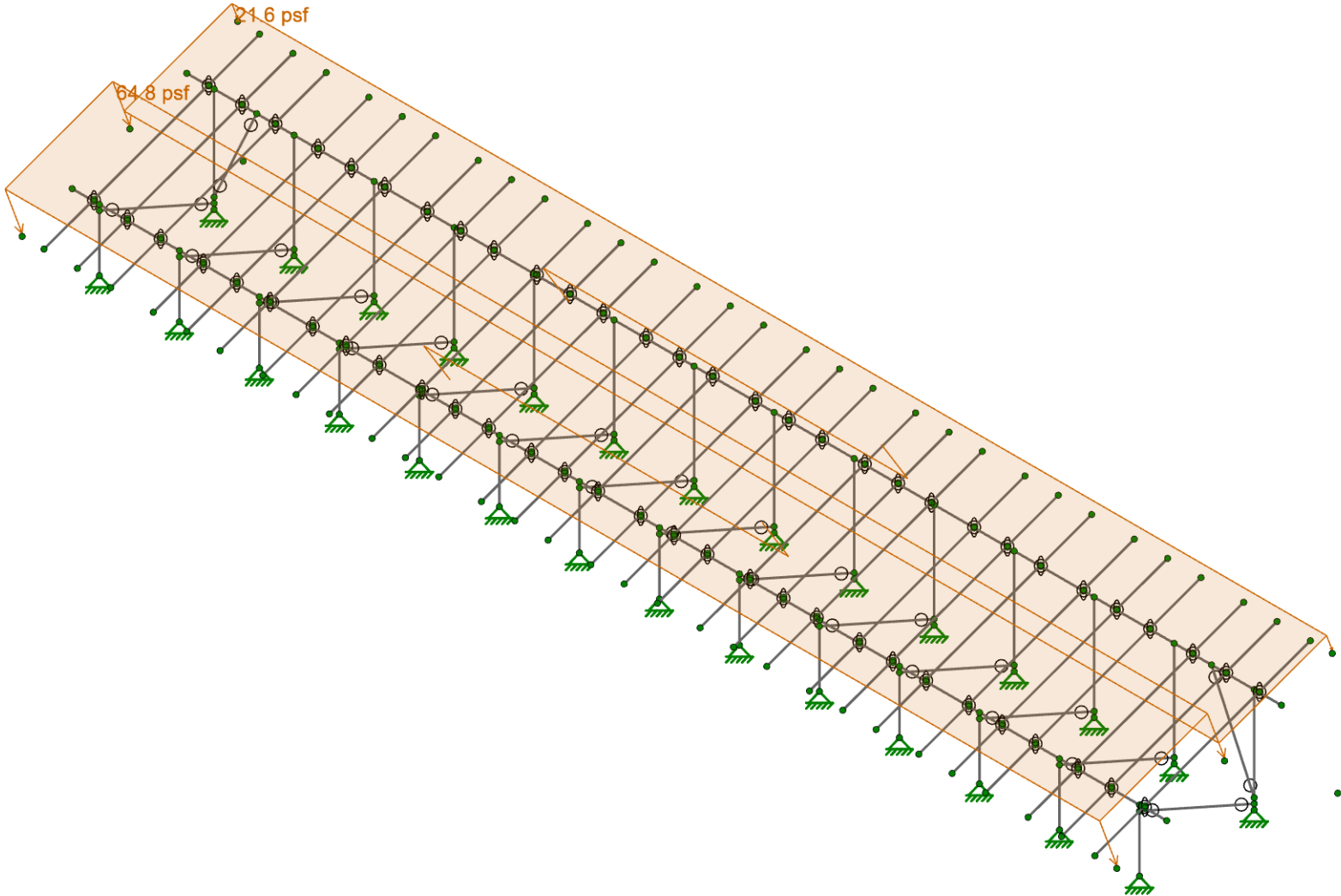
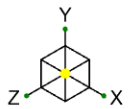

Loads: BLC 7, Wind B 180 deg

 IRISA A NEMETSCHKE COMPANY	Vector Structural Engineering
	CJT
	U2716.0385.241

A16 Standard Panels - 20 Degree Tilt

SK-10
Mar 20, 2024
Sunturf A16 - SP - 20deg.r3d

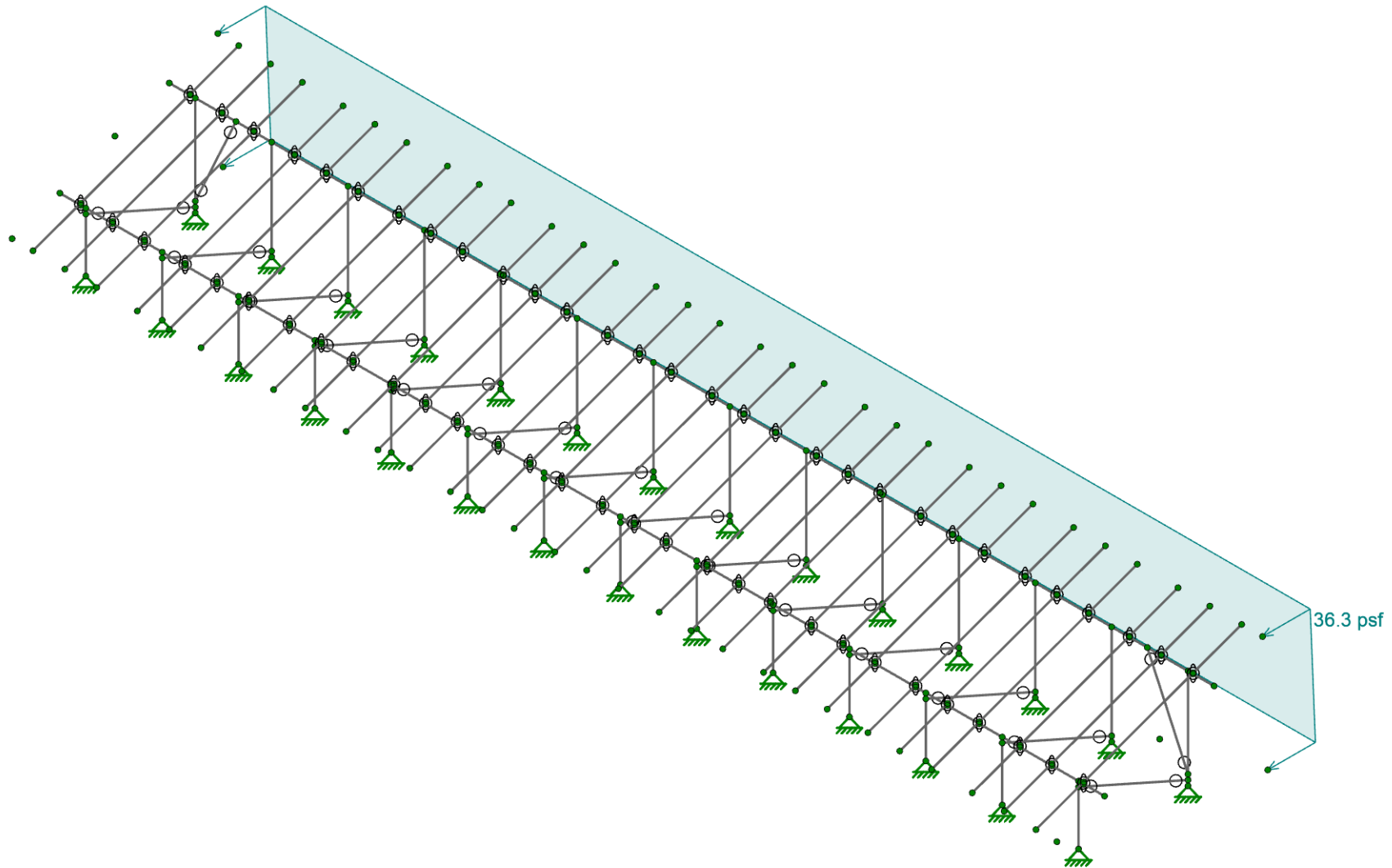
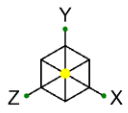

Loads: BLC 8, Wind Z



Vector Structural Engineering
CJT
U2716.0385.241

A16 Standard Panels - 20 Degree Tilt

SK-11
Mar 20, 2024
Sunturf A16 - SP - 20deg.r3d

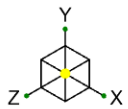

Code Check (Env)

- No Calc
- > 1.0
- .90-1.0
- .75-.90
- .50-.75
- 0-.50

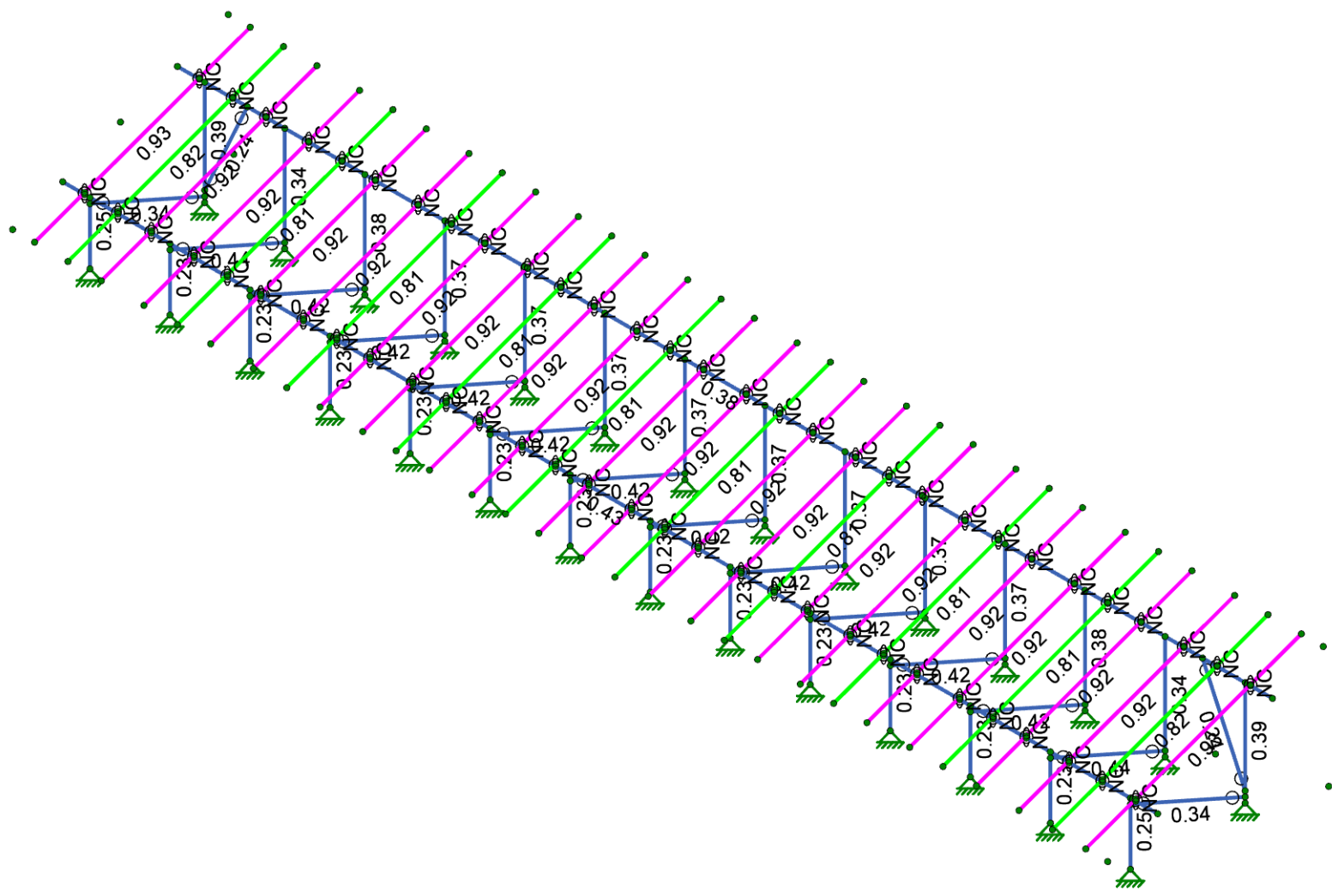

Member Code Checks Displayed (Enveloped)

	Vector Structural Engineering	A16 Standard Panels - 20 Degree Tilt	SK-12
	CJT		Mar 20, 2024
	U2716.0385.241		Sunturf A16 - SP - 20deg.r3d

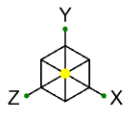

Shear Check (Env)

- No Calc
- > 1.0
- .90-1.0
- .75-.90
- .50-.75
- 0.-.50

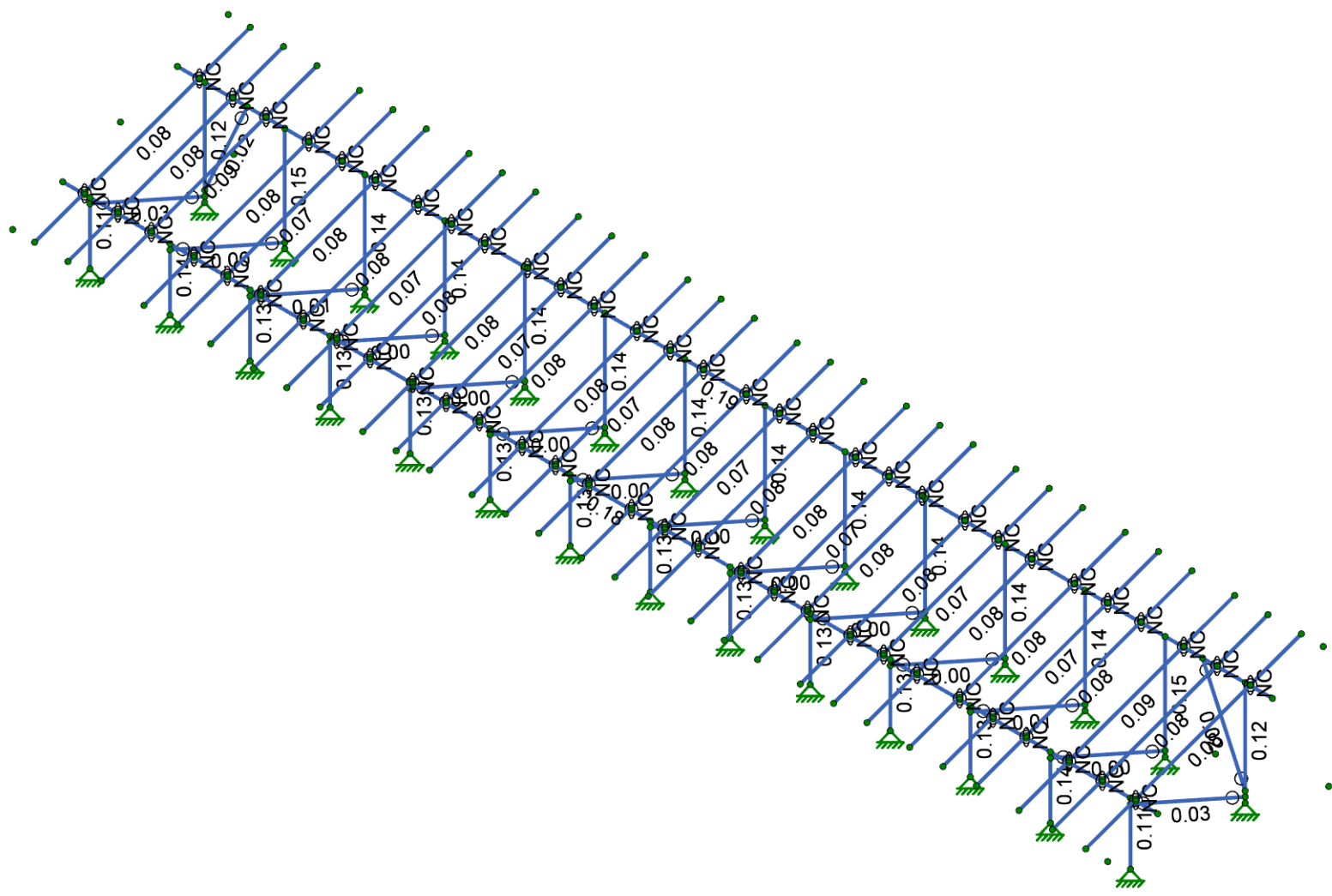

Member Shear Checks Displayed (Enveloped)

 <p>IRISA A NEMETSCHKE COMPANY</p>	Vector Structural Engineering	A16 Standard Panels - 20 Degree Tilt	SK-13
	CJT		Mar 20, 2024
	U2716.0385.241		Sunturf A16 - SP - 20deg.r3d

Model Settings

Number of Reported Sections	5
Number of Internal Sections	100
Member Area Load Mesh Size (in ²)	144
Consider Shear Deformation	Yes
Consider Torsional Warping	Yes
Approximate Mesh Size (in)	24
Transfer Forces Between Intersecting Wood Walls	Yes
Increase Wood Wall Nailing Capacity for Wind Loads	Yes
Include P-Delta for Walls	Yes
Optimize Masonry and Wood Walls	Yes
Maximum Number of Iterations	3
Single	No
Multiple (Optimum)	Yes
Maximum	No

Global Axis corresponding to vertical direction	Y
Convert Existing Data	Yes
Default Global Plane for z-axis	XZ
Plate Local Axis Orientation	Nodal

Hot Rolled Steel	AISC 15th (360-16): ASD
Stiffness Adjustment	Yes (Iterative)
Notional Annex	None
Connections	None
Cold Formed Steel	None
Stiffness Adjustment	Yes (Iterative)
Wood	None
Temperature	< 100F
Concrete	ACI 318-19
Masonry	None
Aluminum	AA ADM1-20: ASD
Structure Type	Building
Stiffness Adjustment	Yes (Iterative)
Stainless	None
Stiffness Adjustment	Yes (Iterative)

Compression Stress Block	Rectangular Stress Block
Analyze using Cracked Sections	No
Leave room for horizontal rebar splices (2*d bar spacing)	Yes
List forces which were ignored for design in the Detail Report	Yes

Column Min Steel	1
Column Max Steel	8
Rebar Material Spec	ASTM A615
Warn if beam-column framing arrangement is not understood	No
Number of Shear Regions	4
Region 2 & 3 Spacing Increase Increment (in)	3.999992



Company : Vector Structural Engineering
Designer : CJT
Job Number : U2716.0385.241
Model Name : A16 Standard Panels - 20 Degre...

3/20/2024
4:17:07 PM
Checked By : MIH

Model Settings (Continued)

T Z (sec)	
T X (sec)	
C _Z	0.02
C _X	0.02
R Z	3
R X	3

Hot Rolled Steel Properties

	Label	E [ksi]	G [ksi]	Nu	Therm. Coeff. [1e ⁵ F ⁻¹]	Density [lb/ft ³]	Yield [psi]	Ry	Fu [psi]	Rt
1	A992	29000	11154	0.3	0.65	490	50000	1.1	65000	1.1
2	A36 Gr.36	29000	11154	0.3	0.65	490	36000	1.5	58000	1.2
3	A572 Gr.50	29000	11154	0.3	0.65	490	50000	1.1	65000	1.1
4	A500 Gr.B RND	29000	11154	0.3	0.65	527	42000	1.4	58000	1.3
5	A500 Gr.B Rect	29000	11154	0.3	0.65	527	46000	1.4	58000	1.3
6	A53 Gr.B	29000	11154	0.3	0.65	490	35000	1.6	60000	1.2
7	A1085	29000	11154	0.3	0.65	490	50000	1.4	65000	1.3

Aluminum Properties

	Label	E [ksi]	G [ksi]	Nu	Therm. Coeff. [1e ⁵ F ⁻¹]	Density [lb/ft ³]	Table B.4	kt	Ftu [psi]	Fty [psi]	Fcy [psi]	Fsu [psi]	Ct
1	3003-H14	10100	3787.5	0.33	1.3	172.8	Table B.4-1	1	19000	16000	13000	12000	141
2	6061-T6	10100	3787.5	0.33	1.3	172.8	Table B.4-2	1	38000	35000	35000	24000	141
3	6063-T5	10100	3787.5	0.33	1.3	172.8	Table B.4-2	1	22000	16000	16000	13000	141
4	6063-T6	10100	3787.5	0.33	1.3	172.8	Table B.4-2	1	30000	25000	25000	19000	141
5	5052-H34	10200	3787.5	0.33	1.3	172.8	Table B.4-1	1	34000	26000	24000	20000	141
6	6061-T6 W	10100	3787.5	0.33	1.3	172.8	Table B.4-1	1	24000	15000	15000	15000	141
7	6005-T5	10100	3787.5	0.33	1.3	172.8	Table B.4-1	1	38000	35000	35000	24000	141

Hot Rolled Steel Section Sets

	Label	Shape	Type	Design List	Material	Design Rule	Area [in ²]	Iyy [in ⁴]	Izz [in ⁴]	J [in ⁴]
1	Post	PIPE2.0A21165	Column	Pipe	A572 Gr.50	Typical	0.776	0.499	0.499	0.998
2	Cross Beam	PIPE2.5A21168	Beam	Wide Flange	A572 Gr.50	Typical	0.947	0.907	0.907	1.814
3	Diagonal Brace	1.5X1.5X0.083	HBrace	SquareTube	A572 Gr.50	Typical	0.47	0.158	0.158	0.236

Aluminum Section Sets

	Label	Shape	Type	Design List	Material	Design Rule	Area [in ²]	Iyy [in ⁴]	Izz [in ⁴]	J [in ⁴]
1	AL Posts	2.375ODX0.188	Column	Pipe	6005-T5	Typical	1.29	0.778	0.778	1.54
2	AL Brace	RT1.5X2X0.15625	VBrace	Rectangular Tubes	6005-T5	Typical	0.996	0.327	0.524	0.602
3	AL Rails	HR300 ALA	Beam	Rectangular Tubes	6005-T5	Typical	0.736	0.214	0.727	0.734
4	AL Cross Beam	CROSSRAIL	Beam	Rectangular Tubes	6005-T5	Typical	1.909	1.97	4.366	4.017

Basic Load Cases

	BLC Description	Category	Y Gravity	Distributed	Area(Member)
1	Self Weight	DL	-1.05		
2	Solar Panel Weight	DL			1
3	Roof Live/Snow	RLL			1
4	Wind A 0 deg	OL1			2
5	Wind B 0 deg	OL2			2
6	Wind A 180 deg	OL3			2
7	Wind B 180 deg	OL4			2
8	Wind Z	WLZ			1
9	BLC 2 Transient Area Loads	None		54	
10	BLC 3 Transient Area Loads	None		54	
11	BLC 4 Transient Area Loads	None		184	
12	BLC 5 Transient Area Loads	None		184	
13	BLC 6 Transient Area Loads	None		184	
14	BLC 7 Transient Area Loads	None		184	
15	BLC 8 Transient Area Loads	None		120	

Member Area Loads (BLC 2 : Solar Panel Weight)

	Node A	Node B	Node C	Node D	Direction	Load	Direction	A Magnitude [psf]	B Magnitude [psf]	C Magnitude [psf]	D Magnitude [psf]	Exclude Braces
1	N197	N200	N199	N196	Y	A-B		-3	-3	-3	-3	Yes

Member Area Loads (BLC 3 : Roof Live/Snow)

	Node A	Node B	Node C	Node D	Direction	Load	Direction	A Magnitude [psf]	B Magnitude [psf]	C Magnitude [psf]	D Magnitude [psf]	Exclude Braces
1	N197	N200	N199	N196	PY	A-B		-53	-53	-53	-53	Yes

Member Area Loads (BLC 4 : Wind A 0 deg)

	Node A	Node B	Node C	Node D	Direction	Load	Direction	A Magnitude [psf]	B Magnitude [psf]	C Magnitude [psf]	D Magnitude [psf]	Exclude Braces
1	N197	N200	N201	N198	Perp	A-B		-40.1	-40.1	-40.1	-40.1	Yes
2	N198	N201	N199	N196	Perp	A-B		-46.3	-46.3	-46.3	-46.3	Yes

Member Area Loads (BLC 5 : Wind B 0 deg)

	Node A	Node B	Node C	Node D	Direction	Load	Direction	A Magnitude [psf]	B Magnitude [psf]	C Magnitude [psf]	D Magnitude [psf]	Exclude Braces
1	N197	N200	N201	N198	Perp	A-B		-67.9	-67.9	-67.9	-67.9	Yes
2	N198	N201	N199	N196	Perp	A-B		-6.2	-6.2	-6.2	-6.2	Yes

Member Area Loads (BLC 6 : Wind A 180 deg)

	Node A	Node B	Node C	Node D	Direction	Load	Direction	A Magnitude [psf]	B Magnitude [psf]	C Magnitude [psf]	D Magnitude [psf]	Exclude Braces
1	N197	N200	N201	N198	Perp	A-B		52.5	52.5	52.5	52.5	Yes
2	N198	N201	N199	N196	Perp	A-B		49.4	49.4	49.4	49.4	Yes

Member Area Loads (BLC 7 : Wind B 180 deg)

	Node A	Node B	Node C	Node D	Direction	Load	Direction	A Magnitude [psf]	B Magnitude [psf]	C Magnitude [psf]	D Magnitude [psf]	Exclude Braces
1	N197	N200	N201	N198	Perp	A-B		21.6	21.6	21.6	21.6	Yes
2	N198	N201	N199	N196	Perp	A-B		64.8	64.8	64.8	64.8	Yes

Member Area Loads (BLC 8 : Wind Z)

	Node A	Node B	Node C	Node D	Direction	Load	Direction	A Magnitude [psf]	B Magnitude [psf]	C Magnitude [psf]	D Magnitude [psf]	Exclude Braces
1	N200	N197	N307	N308	Z	Open Structure		36.3	36.3	36.3	36.3	Yes

Load Combinations

	Description	Solve	P-Delta	BLC	Factor	BLC	Factor	BLC	Factor	BLC	Factor
1	ASD Loads		Y								
2	1.0 D	Yes	Y	DL	1						
3	1.0 D + 1.0 S	Yes	Y	DL	1	RLL	1				
4	1.0 D + 0.6 W1	Yes	Y	DL	1	RLL		OL1	0.6	WLZ	0.6
5	1.0 D + 0.6 W2	Yes	Y	DL	1	RLL		OL2	0.6	WLZ	0.6
6	1.0 D + 0.6 W3	Yes	Y	DL	1	RLL		OL3	0.6	WLZ	-0.6
7	1.0 D + 0.6 W4	Yes	Y	DL	1	RLL		OL4	0.6	WLZ	-0.6
8	1.0 D + 0.45 W1 + 0.75 S	Yes	Y	DL	1	RLL	0.75	OL1	0.45	WLZ	0.45
9	1.0 D + 0.45 W2 + 0.75 S	Yes	Y	DL	1	RLL	0.75	OL2	0.45	WLZ	0.45
10	1.0 D + 0.45 W3 + 0.75 S	Yes	Y	DL	1	RLL	0.75	OL3	0.45	WLZ	-0.45
11	1.0 D + 0.45 W4 + 0.75 S	Yes	Y	DL	1	RLL	0.75	OL4	0.45	WLZ	-0.45
12	0.6 D + 0.6 W1	Yes	Y	DL	0.6	RLL		OL1	0.6	WLZ	0.6
13	0.6 D + 0.6 W2	Yes	Y	DL	0.6	RLL		OL2	0.6	WLZ	0.6

Load Combinations (Continued)

	Description	Solve	P-Delta	BLC	Factor	BLC	Factor	BLC	Factor	BLC	Factor
14	0.6 D + 0.6 W3	Yes	Y	DL	0.6	RLL		OL3	0.6	WLZ	-0.6
15	0.6 D + 0.6 W4	Yes	Y	DL	0.6	RLL		OL4	0.6	WLZ	-0.6
16			Y								
17	LRFD Loads		Y								
18	1.4 D		Y	DL	1.4	RLL					
19	1.2 D + 1.6 S + 0.5 W1		Y	DL	1.2	RLL	1.6	OL1	0.5		
20	1.2 D + 1.6 S + 0.5 W2		Y	DL	1.2	RLL	1.6	OL2	0.5		
21	1.2 D + 1.6 S + 0.5 W3		Y	DL	1.2	RLL	1.6	OL3	0.5		
22	1.2 D + 1.6 S + 0.5 W4		Y	DL	1.2	RLL	1.6	OL4	0.5		
23	1.2 D + 1.0 W1		Y	DL	1.2	RLL		OL1	1		
24	1.2 D + 1.0 W2		Y	DL	1.2	RLL		OL2	1		
25	1.2 D + 1.0 W3		Y	DL	1.2	RLL		OL3	1		
26	1.2 D + 1.0 W4		Y	DL	1.2	RLL		OL4	1		
27	0.9 D + 1.0 W1		Y	DL	0.9	RLL		OL1	1		
28	0.9 D + 1.0 W2		Y	DL	0.9	RLL		OL2	1		
29	0.9 D + 1.0 W3		Y	DL	0.9	RLL		OL3	1		
30	0.9 D + 1.0 W4		Y	DL	0.9	RLL		OL4	1		

Envelope Node Reactions

	Node Label	X [lb]	LC	Y [lb]	LC	Z [lb]	LC	MX [lb-ft]	LC	MY [lb-ft]	LC	MZ [lb-ft]	LC	
1	N2	max	57.248	11	1671.117	11	55.184	4	0	15	0	15	0	15
2		min	-18.551	12	-237.959	12	-67.39	6	0	2	0	2	0	2
3	N1	max	336.66	10	2732.535	10	772.633	6	0	15	0	15	0	15
4		min	-194.83	13	-1724.379	13	-670.087	4	0	2	0	2	0	2
5	N151	max	194.831	13	2732.512	10	772.616	6	0	15	0	15	0	15
6		min	-336.665	10	-1724.378	13	-670.072	4	0	2	0	2	0	2
7	N152	max	18.551	12	1671.143	11	55.182	4	0	15	0	15	0	15
8		min	-57.242	11	-237.964	12	-67.388	6	0	2	0	2	0	2
9	N276	max	10.225	10	2362.054	10	985.342	6	0	15	0	15	0	15
10		min	-6.083	13	-1536.029	13	-851.53	4	0	2	0	2	0	2
11	N278	max	3.856	12	2146.696	11	62.963	4	0	15	0	15	0	15
12		min	-12.716	11	-311.934	12	-77.432	6	0	2	0	2	0	2
13	N239	max	2.862	13	2874.659	10	956.869	6	0	15	0	15	0	15
14		min	-4.638	10	-1847.846	13	-828.234	4	0	2	0	2	0	2
15	N241	max	1.803	12	2055.621	11	64.333	4	0	15	0	15	0	15
16		min	-4.299	11	-288.813	12	-78.845	6	0	2	0	2	0	2
17	N245	max	2.868	10	2786.221	10	949.904	6	0	15	0	15	0	15
18		min	-1.652	13	-1786.892	13	-821.638	4	0	2	0	2	0	2
19	N247	max	4.924	11	2084.983	11	64.376	4	0	15	0	15	0	15
20		min	-1.126	12	-306.046	12	-79.008	6	0	2	0	2	0	2
21	N251	max	4.743	10	2797.989	10	959.538	6	0	15	0	15	0	15
22		min	-2.69	13	-1798.887	13	-829.794	4	0	2	0	2	0	2
23	N253	max	11.476	11	2056.46	11	64.684	4	0	15	0	15	0	15
24		min	-3.444	12	-290.728	12	-79.314	6	0	2	0	2	0	2
25	N257	max	2.793	13	2774.611	10	944.358	6	0	15	0	15	0	15
26		min	-4.441	10	-1776.029	13	-817.302	4	0	2	0	2	0	2
27	N259	max	2.645	12	2051.79	11	64.194	4	0	15	0	15	0	15
28		min	-9.899	11	-297.879	12	-78.757	6	0	2	0	2	0	2
29	N263	max	1.655	13	2809.016	10	957.08	6	0	15	0	15	0	15
30		min	-2.734	10	-1805.299	13	-827.772	4	0	2	0	2	0	2
31	N265	max	1.995	12	2080.898	11	64.59	4	0	15	0	15	0	15
32		min	-6.659	11	-299.567	12	-79.27	6	0	2	0	2	0	2
33	N269	max	2.734	10	2809.006	10	957.08	6	0	15	0	15	0	15
34		min	-1.655	13	-1805.293	13	-827.773	4	0	2	0	2	0	2
35	N271	max	6.658	11	2080.887	11	64.59	4	0	15	0	15	0	15

Envelope Node Reactions (Continued)

Node Label		X [lb]	LC	Y [lb]	LC	Z [lb]	LC	MX [lb-ft]	LC	MY [lb-ft]	LC	MZ [lb-ft]	LC
36		min	12	-1.995	12	-299.564	12	-79.27	6	0	2	0	2
37	N275	max	10	4.441	10	2774.584	10	944.353	6	0	15	0	15
38		min	13	-2.794	13	-1776.011	13	-817.298	4	0	2	0	2
39	N445	max	11	9.898	11	2051.779	11	64.193	4	0	15	0	15
40		min	12	-2.645	12	-297.879	12	-78.756	6	0	2	0	2
41	N449	max	13	2.689	13	2797.99	13	959.529	6	0	15	0	15
42		min	10	-4.742	10	-1798.884	10	-829.788	4	0	2	0	2
43	N451	max	12	3.444	12	2056.458	12	64.684	4	0	15	0	15
44		min	11	-11.476	11	-290.732	11	-79.313	6	0	2	0	2
45	N455	max	13	1.652	13	2786.222	13	949.905	6	0	15	0	15
46		min	10	-2.868	10	-1786.893	10	-821.64	4	0	2	0	2
47	N457	max	12	1.126	12	2084.979	12	64.376	4	0	15	0	15
48		min	11	-4.925	11	-306.045	11	-79.008	6	0	2	0	2
49	N461	max	10	4.639	10	2874.648	10	956.86	6	0	15	0	15
50		min	13	-2.863	13	-1847.839	13	-828.226	4	0	2	0	2
51	N463	max	11	4.299	11	2055.639	11	64.332	4	0	15	0	15
52		min	12	-1.803	12	-288.822	12	-78.845	6	0	2	0	2
53	N467	max	13	6.083	13	2362.077	13	985.318	6	0	15	0	15
54		min	10	-10.223	10	-1536.009	10	-851.51	4	0	2	0	2
55	N469	max	11	12.711	11	2146.689	11	62.963	4	0	15	0	15
56		min	12	-3.855	12	-311.957	12	-77.431	6	0	2	0	2
57	Totals:	max	14	0	14	62160.608	14	11971.359	6				
58		min	5	0	5	-21234.357	5	-10412.021	12				

Envelope AISC 15TH (360-16): ASD Member Steel Code Checks

Member	Shape	Code Check	Loc[in]	LC	Shear Check	Loc[in]	LC	DirLC	Pnc/om [lb]	Pnt/om [lb]	Mnyy/om [lb-ft]	Mnzz/om [lb-ft]	Cb	Eqn
1	M5	PIPE2.0A21165	0.247	42.418	11	0.106	42.418	6	18213.687	23232.186	1397.505	1397.505	1	H1-1b
2	M6	PIPE2.0A21165	0.395	7.333	10	0.118	0	6	11590.702	23232.186	1397.505	1397.505	1	H1-1a
3	M15	1.5X1.5X0.083	0.344	48.047	6	0.03	94.133	y 10	2679.684	14085.15	624.421	624.421	1.136	H1-1a
4	M19	1.5X1.5X0.083	0.24	43.406	10	0.018	77.166	y 6	3987.65	14085.15	624.421	624.421	1.136	H1-1a
5	M73	PIPE2.0A21165	0.247	42.418	11	0.106	42.418	6	18213.687	23232.186	1397.505	1397.505	1	H1-1b
6	M74	PIPE2.0A21165	0.395	7.333	10	0.118	0	6	11590.702	23232.186	1397.505	1397.505	1	H1-1a
7	M75	1.5X1.5X0.083	0.344	48.047	6	0.03	94.132	y 10	2679.701	14085.15	624.421	624.421	1.136	H1-1a
8	M75B	1.5X1.5X0.083	0.24	43.406	10	0.018	77.166	y 6	3987.65	14085.15	624.421	624.421	1.136	H1-1a
9	M71	PIPE2.5A21168	0.378	136.813	10	0.186	316.381	10	20336.2	28358.413	2081.747	2081.747	1	H1-1b
10	M72	PIPE2.5A21168	0.432	76.958	11	0.178	316.381	11	20336.2	28358.413	2081.747	2081.747	1	H1-1b
11	M134	PIPE2.0A21165	0.337	3.259	10	0.145	0	6	11590.702	23232.186	1397.505	1397.505	1	H1-1a
12	M135	1.5X1.5X0.083	0.436	48.047	6	0.005	94.132	y 5	2679.701	14085.15	624.421	624.421	1.136	H1-1a
13	M136	PIPE2.0A21165	0.231	42.418	6	0.136	42.418	6	18213.687	23232.186	1397.505	1397.505	1	H1-1b
14	M116	PIPE2.0A21165	0.378	4.074	10	0.142	0	6	11590.702	23232.186	1397.505	1397.505	1	H1-1a
15	M117	1.5X1.5X0.083	0.424	48.047	6	0.005	94.132	y 10	2679.701	14085.15	624.421	624.421	1.136	H1-1a
16	M118	PIPE2.0A21165	0.233	42.418	6	0.131	42.418	6	18213.687	23232.186	1397.505	1397.505	1	H1-1b
17	M119	PIPE2.0A21165	0.37	4.074	10	0.141	0	6	11590.702	23232.186	1397.505	1397.505	1	H1-1a
18	M120	1.5X1.5X0.083	0.421	48.047	6	0.003	94.132	y 3	2679.701	14085.15	624.421	624.421	1.136	H1-1a
19	M121	PIPE2.0A21165	0.234	42.418	6	0.13	42.418	6	18213.687	23232.186	1397.505	1397.505	1	H1-1b
20	M122	PIPE2.0A21165	0.372	4.074	10	0.142	0	6	11590.702	23232.186	1397.505	1397.505	1	H1-1a
21	M123	1.5X1.5X0.083	0.425	48.047	6	0.005	94.132	y 11	2679.701	14085.15	624.421	624.421	1.136	H1-1a
22	M124	PIPE2.0A21165	0.235	42.418	6	0.131	42.418	6	18213.687	23232.186	1397.505	1397.505	1	H1-1b
23	M125	PIPE2.0A21165	0.368	4.074	10	0.14	0	6	11590.702	23232.186	1397.505	1397.505	1	H1-1a
24	M126	1.5X1.5X0.083	0.418	48.047	6	0.004	94.132	y 3	2679.701	14085.15	624.421	624.421	1.136	H1-1a
25	M127	PIPE2.0A21165	0.233	42.418	6	0.129	42.418	6	18213.687	23232.186	1397.505	1397.505	1	H1-1b
26	M128	PIPE2.0A21165	0.373	4.074	10	0.142	0	6	11590.702	23232.186	1397.505	1397.505	1	H1-1a
27	M129	1.5X1.5X0.083	0.424	48.047	6	0.004	94.132	y 10	2679.701	14085.15	624.421	624.421	1.136	H1-1a
28	M130	PIPE2.0A21165	0.235	42.418	6	0.131	42.418	6	18213.687	23232.186	1397.505	1397.505	1	H1-1b
29	M131	PIPE2.0A21165	0.373	4.074	10	0.142	0	6	11590.702	23232.186	1397.505	1397.505	1	H1-1a

Envelope AISC 15TH (360-16): ASD Member Steel Code Checks (Continued)

Member	Shape	Code Check	Loc[in]	LcShear	Check	Loc[in]	DirLcPnc/om	[lb]	Pnt/om	[lb]	Mnyy/om	[lb-ft]	Mnz/om	[lb-ft]	Cb	Eqn
30	M132	1.5X1.5X0.083	0.424	48.047	6	0.004	94.132	y	10	2679.701	14085.15	624.421	624.421	1.136	H1-1a	
31	M217	PIPE2.0A21165	0.235	42.418	6	0.131	42.418		6	18213.687	23232.186	1397.505	1397.505	1	H1-1b	
32	M218	PIPE2.0A21165	0.368	4.074	10	0.14	0		6	11590.702	23232.186	1397.505	1397.505	1	H1-1a	
33	M219	1.5X1.5X0.083	0.418	48.047	6	0.004	94.132	y	3	2679.701	14085.15	624.421	624.421	1.136	H1-1a	
34	M220	PIPE2.0A21165	0.233	42.418	6	0.129	42.418		6	18213.687	23232.186	1397.505	1397.505	1	H1-1b	
35	M221	PIPE2.0A21165	0.372	4.074	10	0.142	0		6	11590.702	23232.186	1397.505	1397.505	1	H1-1a	
36	M222	1.5X1.5X0.083	0.425	48.047	6	0.005	94.132	y	11	2679.701	14085.15	624.421	624.421	1.136	H1-1a	
37	M223	PIPE2.0A21165	0.235	42.418	6	0.131	42.418		6	18213.687	23232.186	1397.505	1397.505	1	H1-1b	
38	M224	PIPE2.0A21165	0.37	4.074	10	0.141	0		6	11590.702	23232.186	1397.505	1397.505	1	H1-1a	
39	M225	1.5X1.5X0.083	0.421	48.047	6	0.003	94.132	y	3	2679.701	14085.15	624.421	624.421	1.136	H1-1a	
40	M226	PIPE2.0A21165	0.234	42.418	6	0.13	42.418		6	18213.687	23232.186	1397.505	1397.505	1	H1-1b	
41	M227	PIPE2.0A21165	0.378	4.074	10	0.142	0		6	11590.702	23232.186	1397.505	1397.505	1	H1-1a	
42	M228	1.5X1.5X0.083	0.424	48.047	6	0.005	94.132	y	10	2679.701	14085.15	624.421	624.421	1.136	H1-1a	
43	M229	PIPE2.0A21165	0.233	42.418	6	0.131	42.418		6	18213.687	23232.186	1397.505	1397.505	1	H1-1b	
44	M230	PIPE2.0A21165	0.337	3.259	10	0.145	0		6	11590.702	23232.186	1397.505	1397.505	1	H1-1a	
45	M231	1.5X1.5X0.083	0.436	48.047	6	0.005	94.132	y	5	2679.701	14085.15	624.421	624.421	1.136	H1-1a	
46	M232	PIPE2.0A21165	0.231	42.418	6	0.136	42.418		6	18213.687	23232.186	1397.505	1397.505	1	H1-1b	

Envelope AA ADM1-20: ASD - BUILDING Member Aluminum Code Checks

Member	Shape	Code Check	Loc[in]	LcShear	Check	Loc[in]	DirLcPnc/Om	[lb]	Pnt/Om	[lb]	Mny/Om	[lb-ft]	Mnz/Om	[lb-ft]	Vny/Om	[lb]	Vnz/Om	[lb]	Cb	Eqn
1	M107	HR300_ALA	0.932	39.417	11	0.084	41.208	y	11	6230.805	14342.564	533.921	934.619	7307.692	3206.154	1.662	H.1-1			
2	M62	HR300_ALA	0.817	39.417	11	0.079	41.208	y	11	6230.805	14342.564	533.921	934.619	7307.692	3206.154	1.62	H.1-1			
3	M65	HR300_ALA	0.918	39.417	11	0.09	41.208	y	11	6230.805	14342.564	533.921	934.619	7307.692	3206.154	1.635	H.1-1			
4	M68	HR300_ALA	0.917	39.417	11	0.08	41.208	y	11	6230.805	14342.564	533.921	934.619	7307.692	3206.154	1.627	H.1-1			
5	M76	HR300_ALA	0.806	39.417	11	0.071	130.792	y	10	6230.805	14342.564	533.921	934.619	7307.692	3206.154	1.629	H.1-1			
6	M79	HR300_ALA	0.918	39.417	11	0.081	41.208	y	11	6230.805	14342.564	533.921	934.619	7307.692	3206.154	1.634	H.1-1			
7	M82	HR300_ALA	0.917	39.417	11	0.08	41.208	y	11	6230.805	14342.564	533.921	934.619	7307.692	3206.154	1.625	H.1-1			
8	M133	HR300_ALA	0.807	39.417	11	0.07	41.208	y	11	6230.805	14342.564	533.921	934.619	7307.692	3206.154	1.636	H.1-1			
9	M139	HR300_ALA	0.917	39.417	11	0.079	41.208	y	11	6230.805	14342.564	533.921	934.619	7307.692	3206.154	1.624	H.1-1			
10	M142	HR300_ALA	0.918	39.417	11	0.079	41.208	y	11	6230.805	14342.564	533.921	934.619	7307.692	3206.154	1.637	H.1-1			
11	M145	HR300_ALA	0.806	39.417	11	0.07	41.208	y	11	6230.805	14342.564	533.921	934.619	7307.692	3206.154	1.621	H.1-1			
12	M148	HR300_ALA	0.918	39.417	11	0.081	41.208	y	11	6230.805	14342.564	533.921	934.619	7307.692	3206.154	1.635	H.1-1			
13	M151	HR300_ALA	0.917	39.417	11	0.08	41.208	y	11	6230.805	14342.564	533.921	934.619	7307.692	3206.154	1.626	H.1-1			
14	M154	HR300_ALA	0.807	39.417	11	0.071	41.208	y	11	6230.805	14342.564	533.921	934.619	7307.692	3206.154	1.632	H.1-1			
15	M157	HR300_ALA	0.917	39.417	11	0.08	41.208	y	11	6230.805	14342.564	533.921	934.619	7307.692	3206.154	1.629	H.1-1			
16	M160	HR300_ALA	0.917	39.417	11	0.08	41.208	y	11	6230.805	14342.564	533.921	934.619	7307.692	3206.154	1.629	H.1-1			
17	M163	HR300_ALA	0.807	39.417	11	0.071	41.208	y	11	6230.805	14342.564	533.921	934.619	7307.692	3206.154	1.632	H.1-1			
18	M166	HR300_ALA	0.917	39.417	11	0.08	41.208	y	11	6230.805	14342.564	533.921	934.619	7307.692	3206.154	1.626	H.1-1			
19	M169	HR300_ALA	0.918	39.417	11	0.081	41.208	y	11	6230.805	14342.564	533.921	934.619	7307.692	3206.154	1.635	H.1-1			
20	M172	HR300_ALA	0.806	39.417	11	0.07	41.208	y	11	6230.805	14342.564	533.921	934.619	7307.692	3206.154	1.621	H.1-1			
21	M175	HR300_ALA	0.918	39.417	11	0.079	41.208	y	11	6230.805	14342.564	533.921	934.619	7307.692	3206.154	1.637	H.1-1			
22	M178	HR300_ALA	0.917	39.417	11	0.079	41.208	y	11	6230.805	14342.564	533.921	934.619	7307.692	3206.154	1.624	H.1-1			
23	M181	HR300_ALA	0.807	39.417	11	0.07	41.208	y	11	6230.805	14342.564	533.921	934.619	7307.692	3206.154	1.636	H.1-1			
24	M184	HR300_ALA	0.917	39.417	11	0.08	41.208	y	11	6230.805	14342.564	533.921	934.619	7307.692	3206.154	1.625	H.1-1			
25	M187	HR300_ALA	0.918	39.417	11	0.081	41.208	y	11	6230.805	14342.564	533.921	934.619	7307.692	3206.154	1.634	H.1-1			
26	M190	HR300_ALA	0.806	39.417	11	0.071	130.792	y	10	6230.805	14342.564	533.921	934.619	7307.692	3206.154	1.629	H.1-1			
27	M193	HR300_ALA	0.917	39.417	11	0.08	41.208	y	11	6230.805	14342.564	533.921	934.619	7307.692	3206.154	1.627	H.1-1			
28	M196	HR300_ALA	0.918	39.417	11	0.09	41.208	y	11	6230.805	14342.564	533.921	934.619	7307.692	3206.154	1.635	H.1-1			
29	M199	HR300_ALA	0.817	39.417	11	0.079	41.208	y	11	6230.805	14342.564	533.921	934.619	7307.692	3206.154	1.62	H.1-1			
30	M202	HR300_ALA	0.932	39.417	11	0.084	41.208	y	11	6230.805	14342.564	533.921	934.619	7307.692	3206.154	1.662	H.1-1			



JOB NO.: U2716.0385.241

PROJECT: SunTurf Package A16

SUBJECT: CALCULATIONS

DESIGN APPROACH ASD

CONNECTION CAPACITY

Location: Column Base (set screws)

Connection Type: M16 Conical Set Screws

Tensile Capacity: 2600 lbs

Tension Load: 1264 lbs

Check Connection: 48.6%

Result: **Select M16 Conical Set Screws**

Note: Uplift capacity. FOS of (2)

CONNECTION CAPACITY

Location: Column to Cross Beam

Connection Type: K10341-002

Tensile Capacity: 2195 lbs

Tension Load: 1032 lbs

Check Connection: 47.0%

Result: **Select K10341-002**

Note: Uplift capacity. FOS of (2)



JOB NO.: U2716.0385.241

PROJECT: SunTurf Package A16

SUBJECT: CALCULATIONS

CONNECTION CAPACITY

Location: Brace to Column

Connection Type: K10219-001

Capacity: 1566 lbs

Tension Load: 784 lbs

Check Connection: 50.1%

Result: **Select K10219-001**

Note: Axial capacity. FOS of (2)

BOLTED TENSION CONNECTION

Location: Rail to Cross Beam

Bolt Grade: A304 SS (A2-70)

Bolt Diameter: 0.375 in

Number of Bolts: 2

Bolt Capacity: 8410 lbs (AISC Equation J3-1)

Tension Load: 721 lbs

Check Bolt: 8.6%

Result: **Select (2) 0.375 in. dia. A304 SS (A2-70) bolts.**

Note:



JOB NO.: U2716.0385.241

PROJECT: Sunturf Package A16 Ground Mount

Framing Analysis

SP - 35 deg

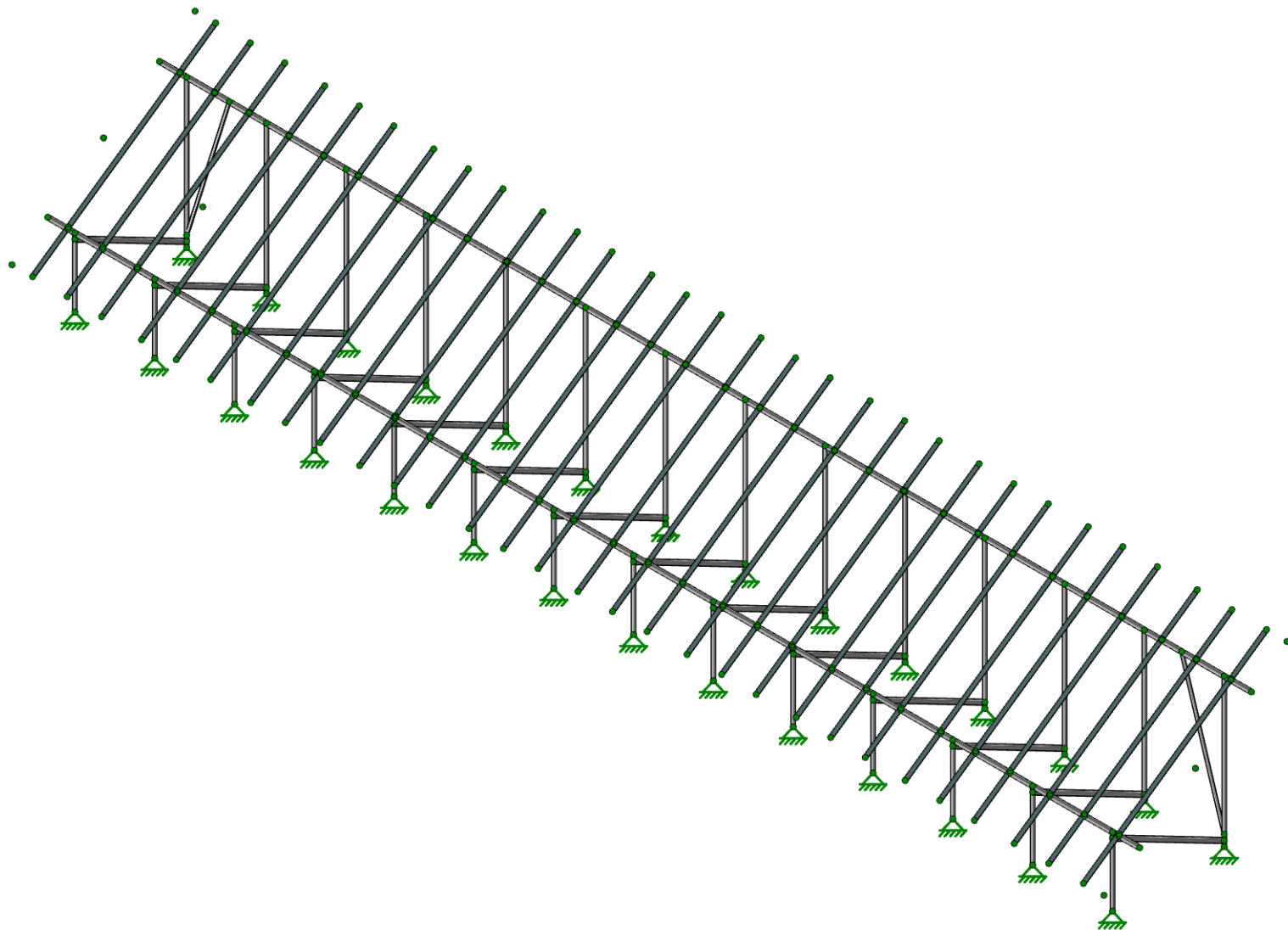
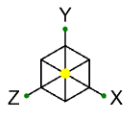

Vector Structural Engineering
CJT
U2716.0385.241

A16 Standard Panels - 35 Degree Tilt

SK-1
Mar 20, 2024
Sunturf A16 - SP - 35deg.r3d

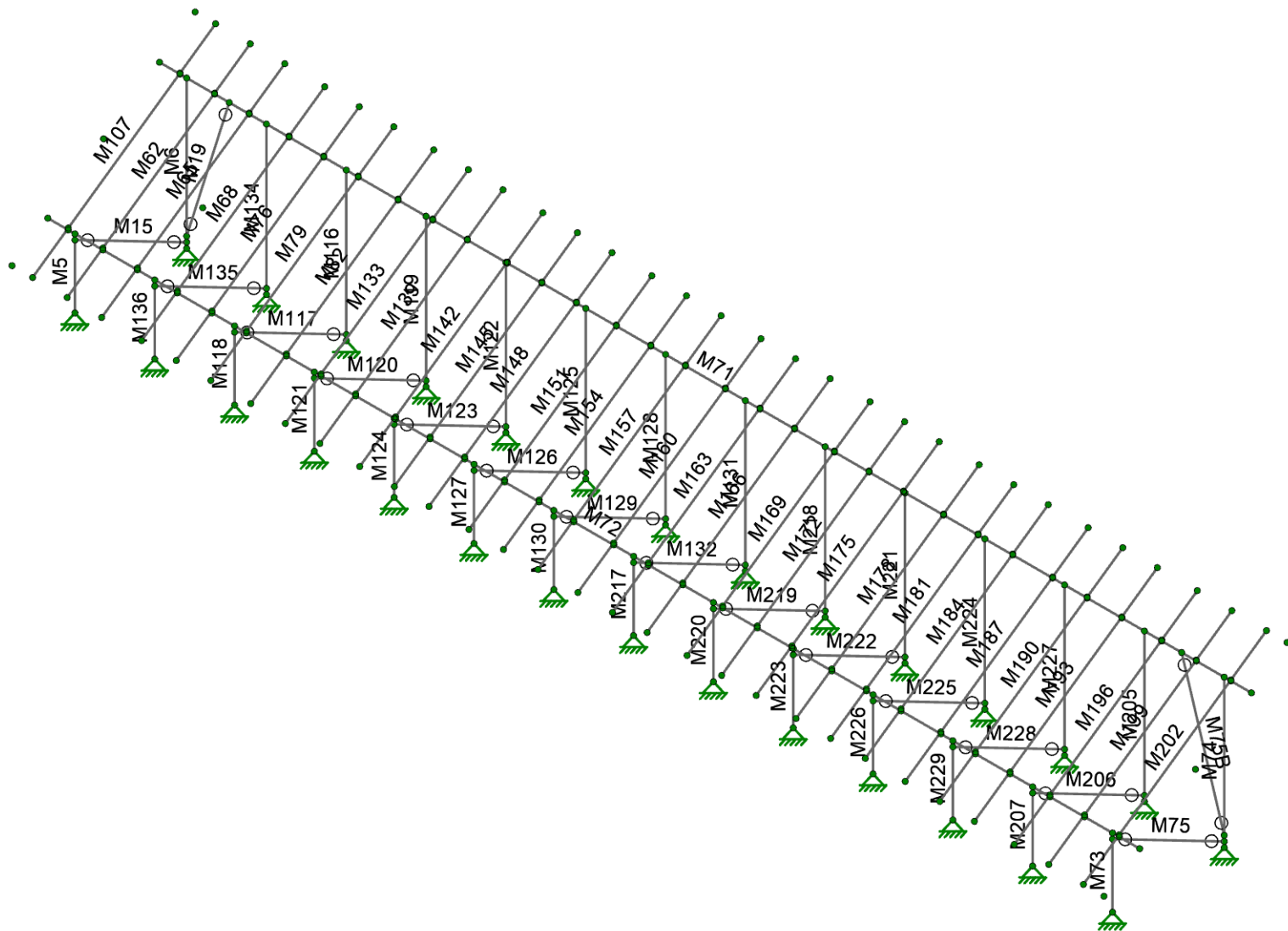
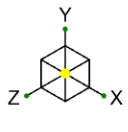

Vector Structural Engineering
CJT
U2716.0385.241

A16 Standard Panels - 35 Degree Tilt

SK-2
Mar 20, 2024
Sunturf A16 - SP - 35deg.r3d

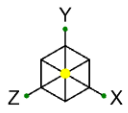

Section Sets

- Post
- Cross Beam
- Diagonal Brace
- Double Brace
- RIGID
- AL Rails

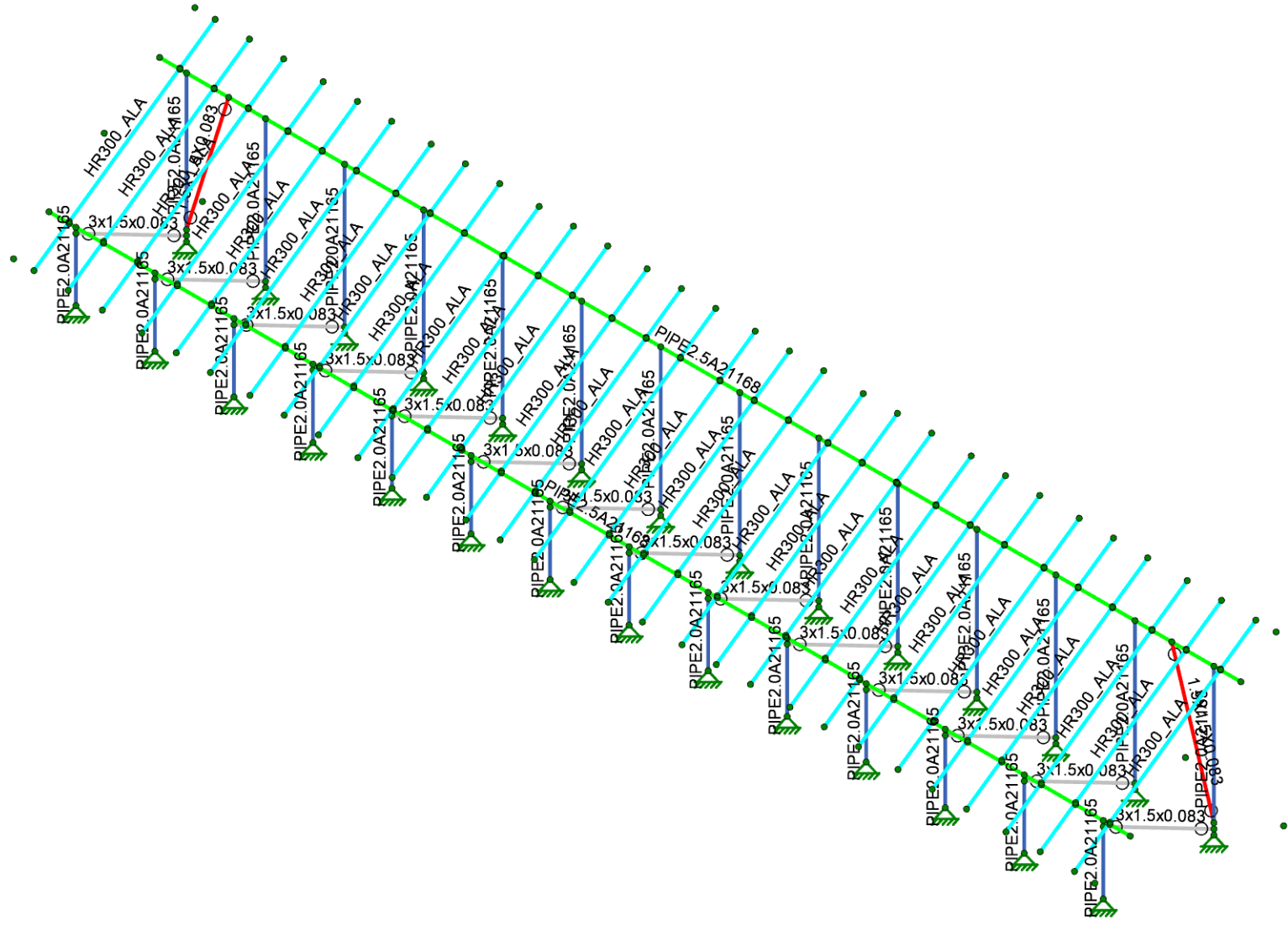

Vector Structural Engineering
 CJT
 U2716.0385.241

A16 Standard Panels - 35 Degree Tilt

SK-3
 Mar 20, 2024
 Sunturf A16 - SP - 35deg.r3d

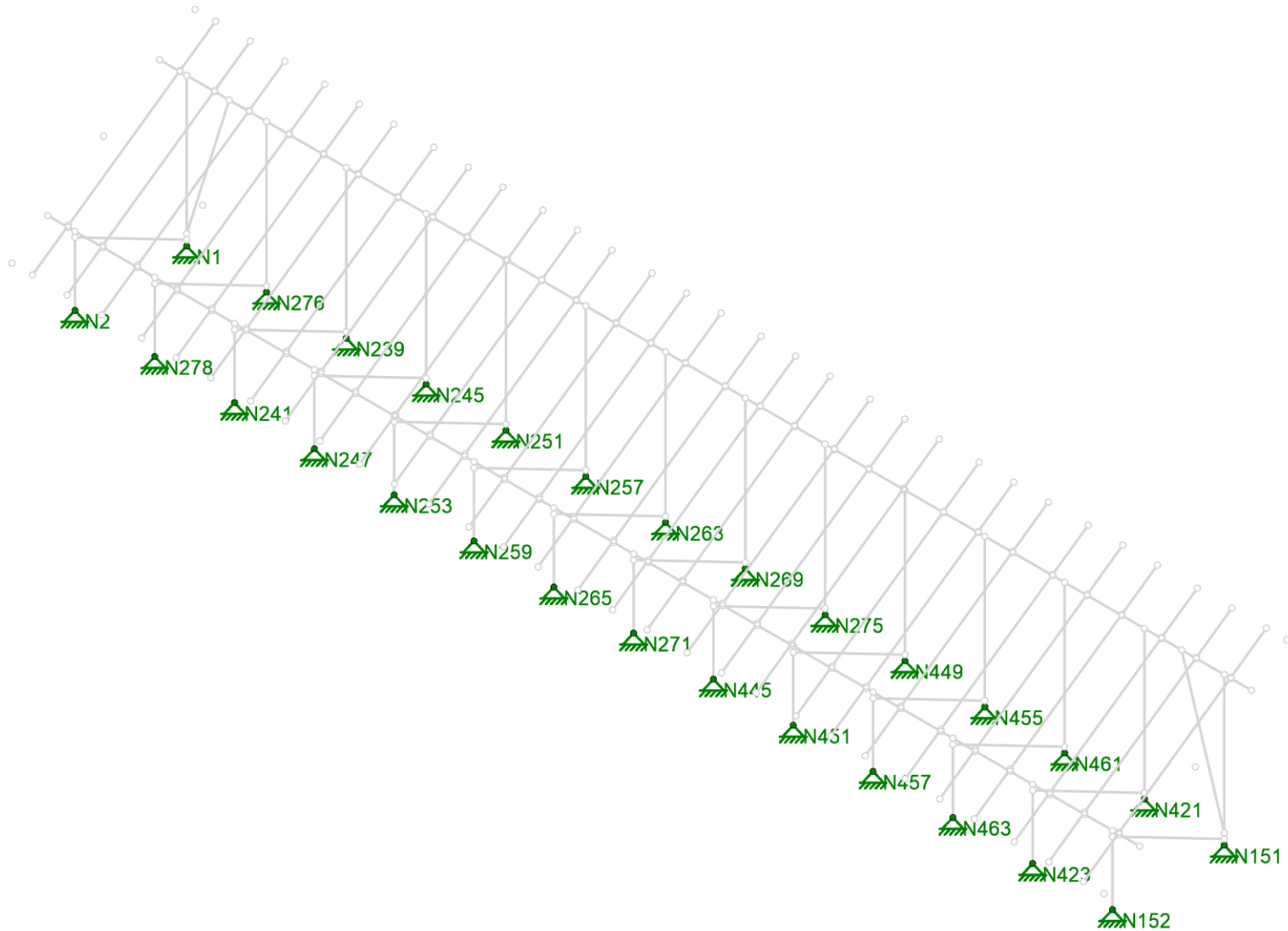
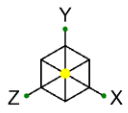

Vector Structural Engineering
 CJT
 U2716.0385.241

A16 Standard Panels - 35 Degree Tilt

SK-4
 Mar 20, 2024
 Sunturf A16 - SP - 35deg.r3d

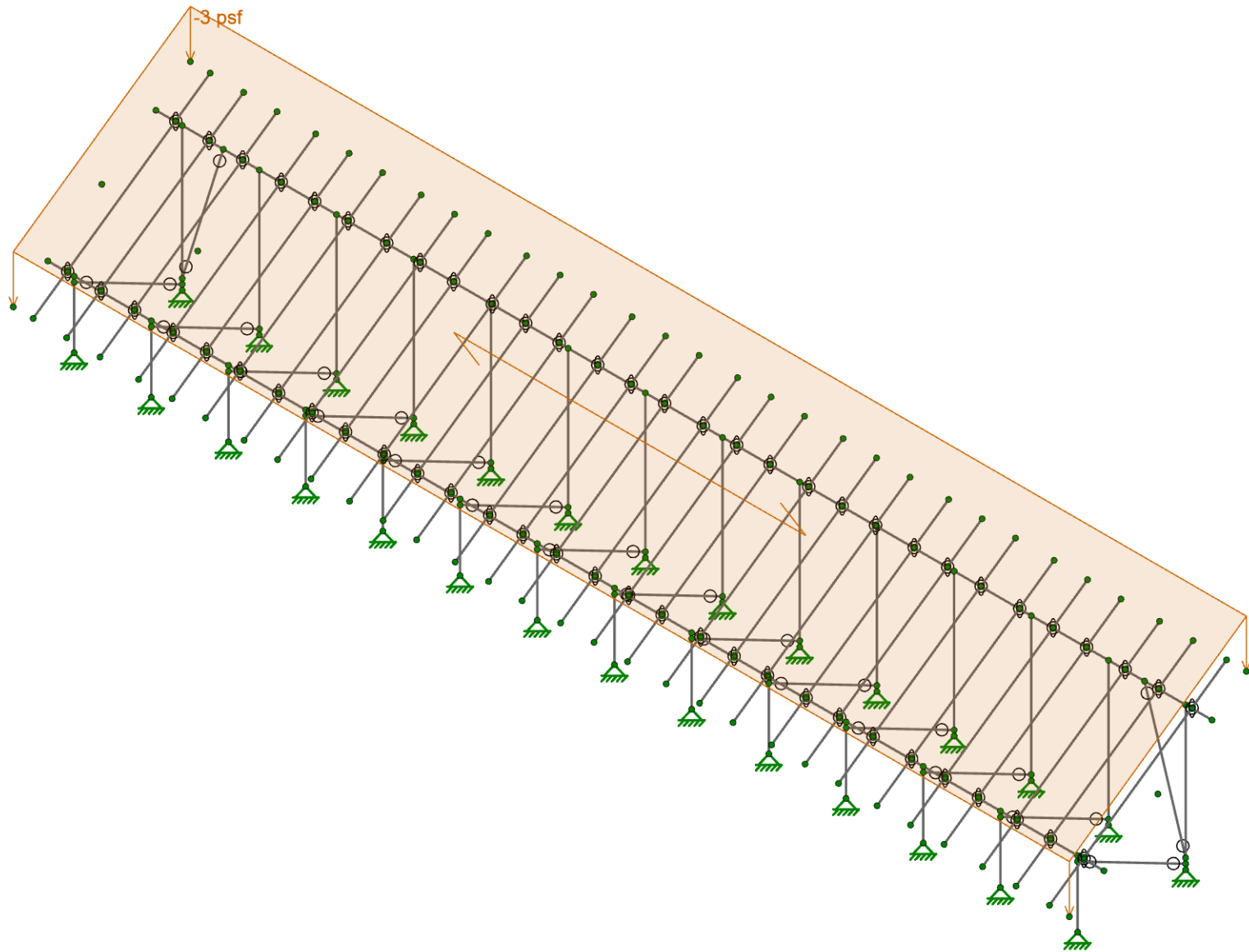
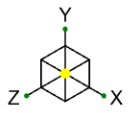

Loads: BLC 2, Solar Panel Weight

	Vector Structural Engineering	A16 Standard Panels - 35 Degree Tilt	SK-5
	CJT		Mar 20, 2024
	U2716.0385.241		Sunturf A16 - SP - 35deg.r3d

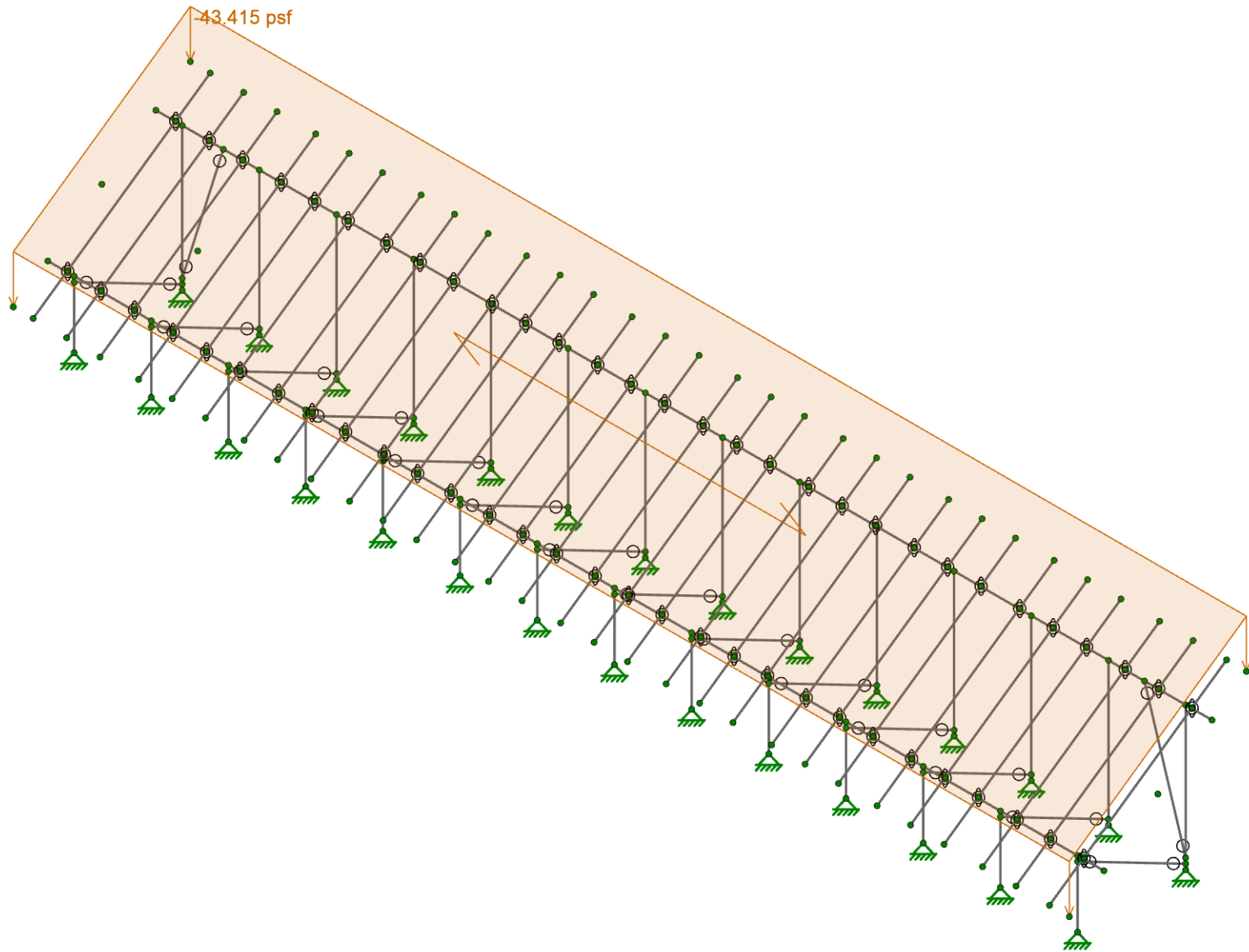
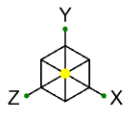

Loads: BLC 3, Roof Live/Snow

	Vector Structural Engineering
	CJT
	U2716.0385.241

A16 Standard Panels - 35 Degree Tilt

SK-6
Mar 20, 2024
Sunturf A16 - SP - 35deg.r3d

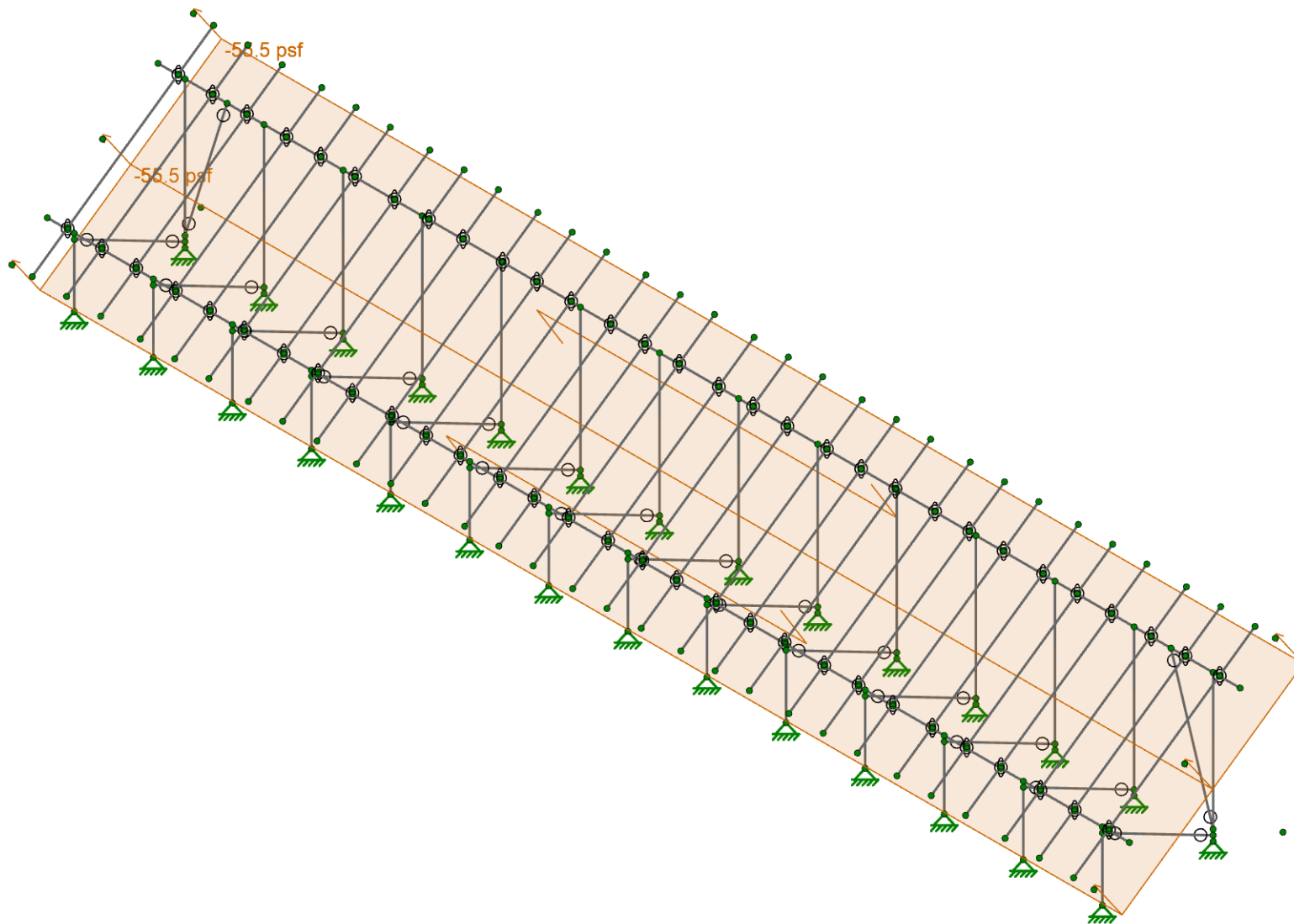
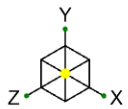

Loads: BLC 4, Wind A 0 deg



Vector Structural Engineering
CJT
U2716.0385.241

A16 Standard Panels - 35 Degree Tilt

SK-7
Mar 20, 2024
Sunturf A16 - SP - 35deg.r3d

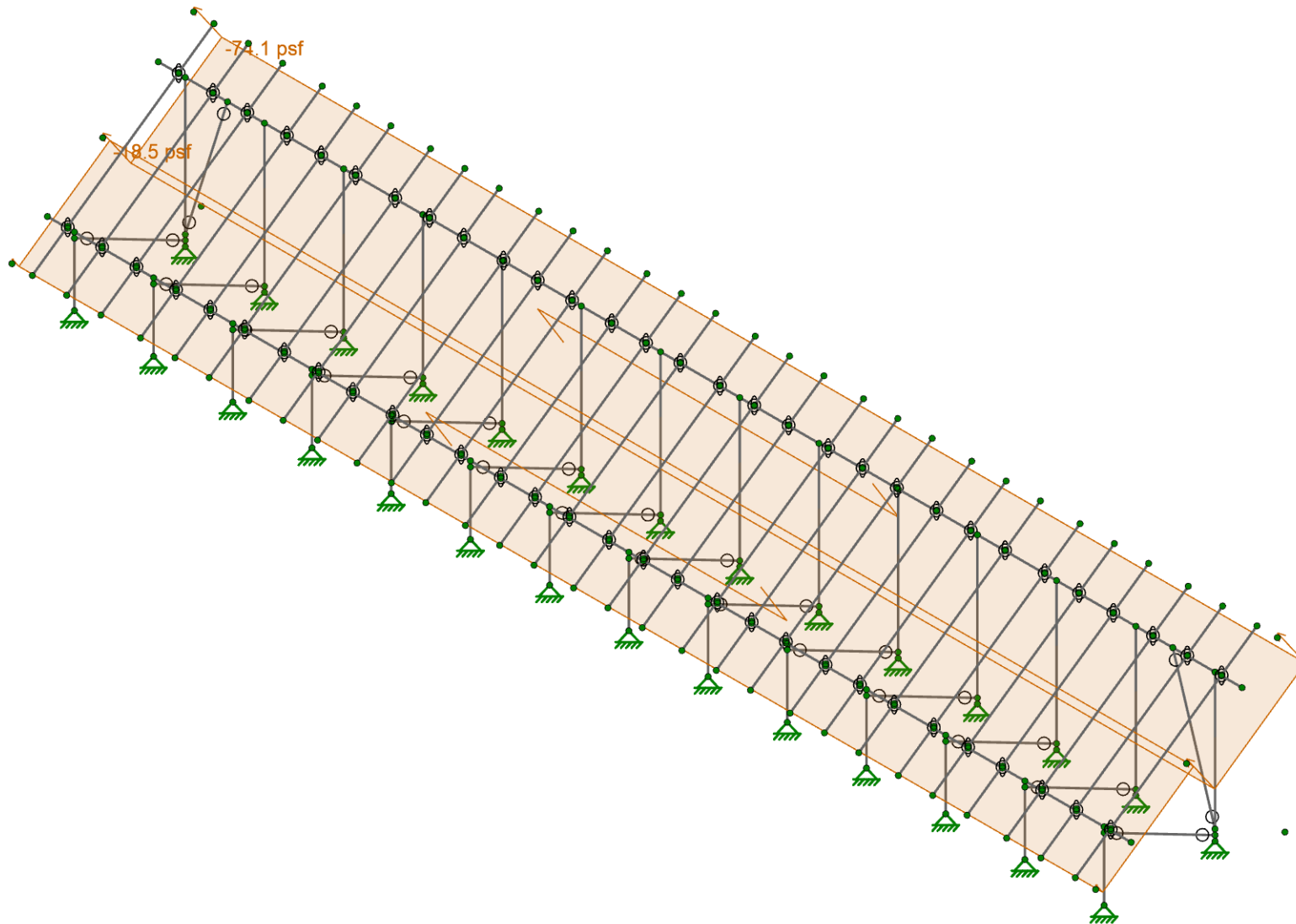
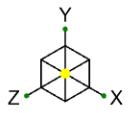

Loads: BLC 5, Wind B 0 deg



Vector Structural Engineering
CJT
U2716.0385.241

A16 Standard Panels - 35 Degree Tilt

SK-8
Mar 20, 2024
Sunturf A16 - SP - 35deg.r3d

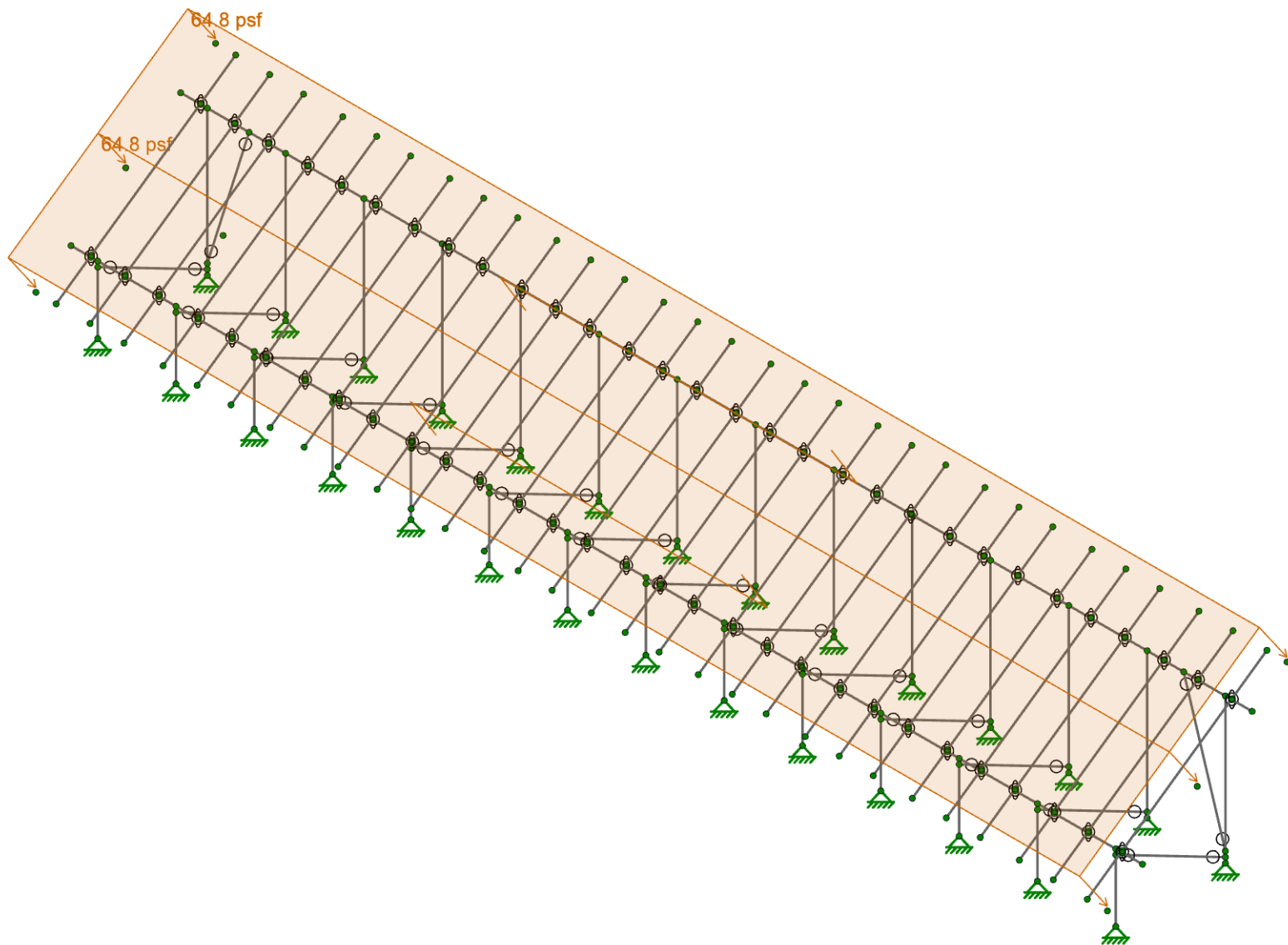
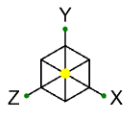

Loads: BLC 6, Wind A 180 deg



Vector Structural Engineering
CJT
U2716.0385.241

A16 Standard Panels - 35 Degree Tilt

SK-9
Mar 20, 2024
Sunturf A16 - SP - 35deg.r3d

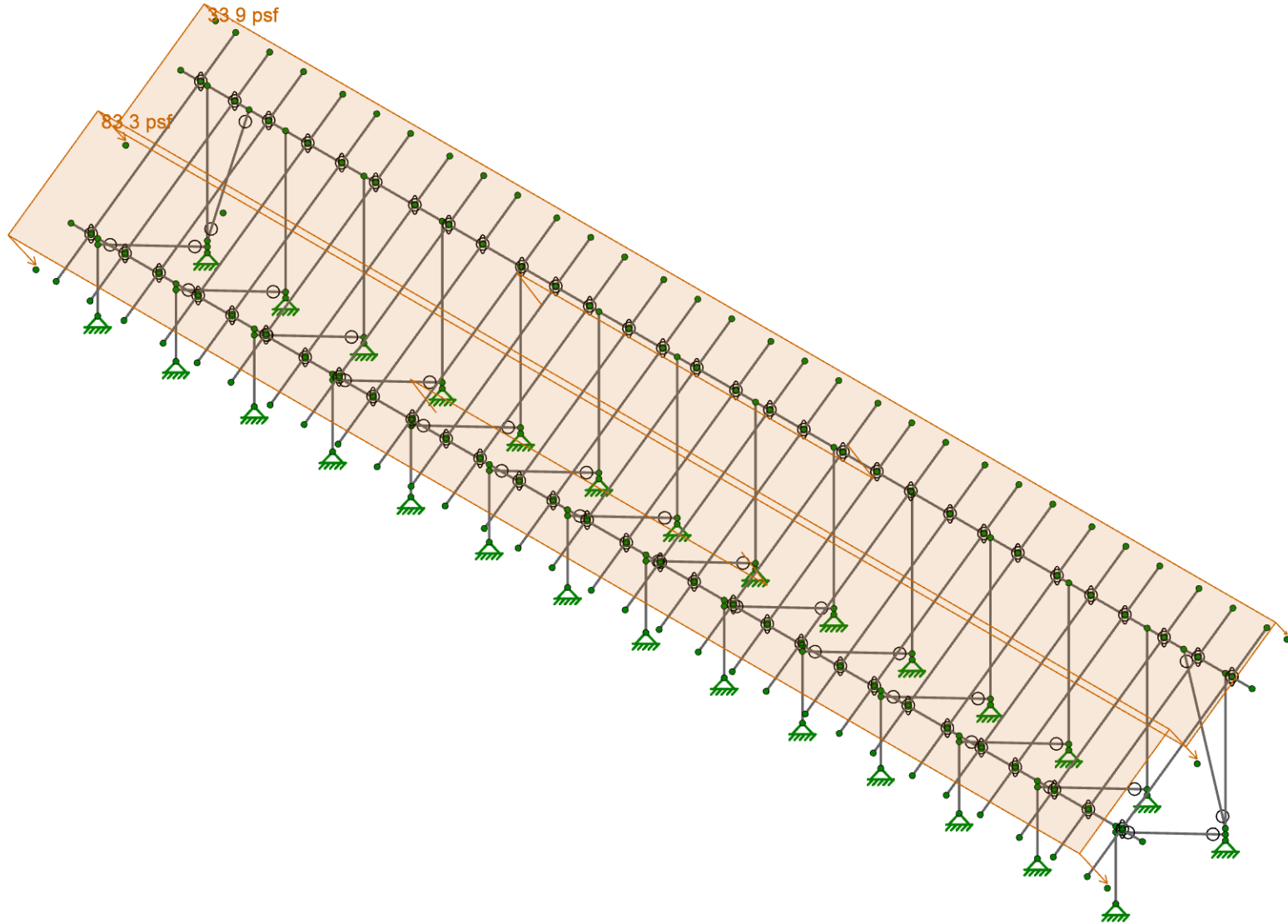
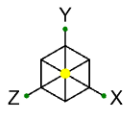

Loads: BLC 7, Wind B 180 deg



Vector Structural Engineering
CJT
U2716.0385.241

A16 Standard Panels - 35 Degree Tilt

SK-10
Mar 20, 2024
Sunturf A16 - SP - 35deg.r3d

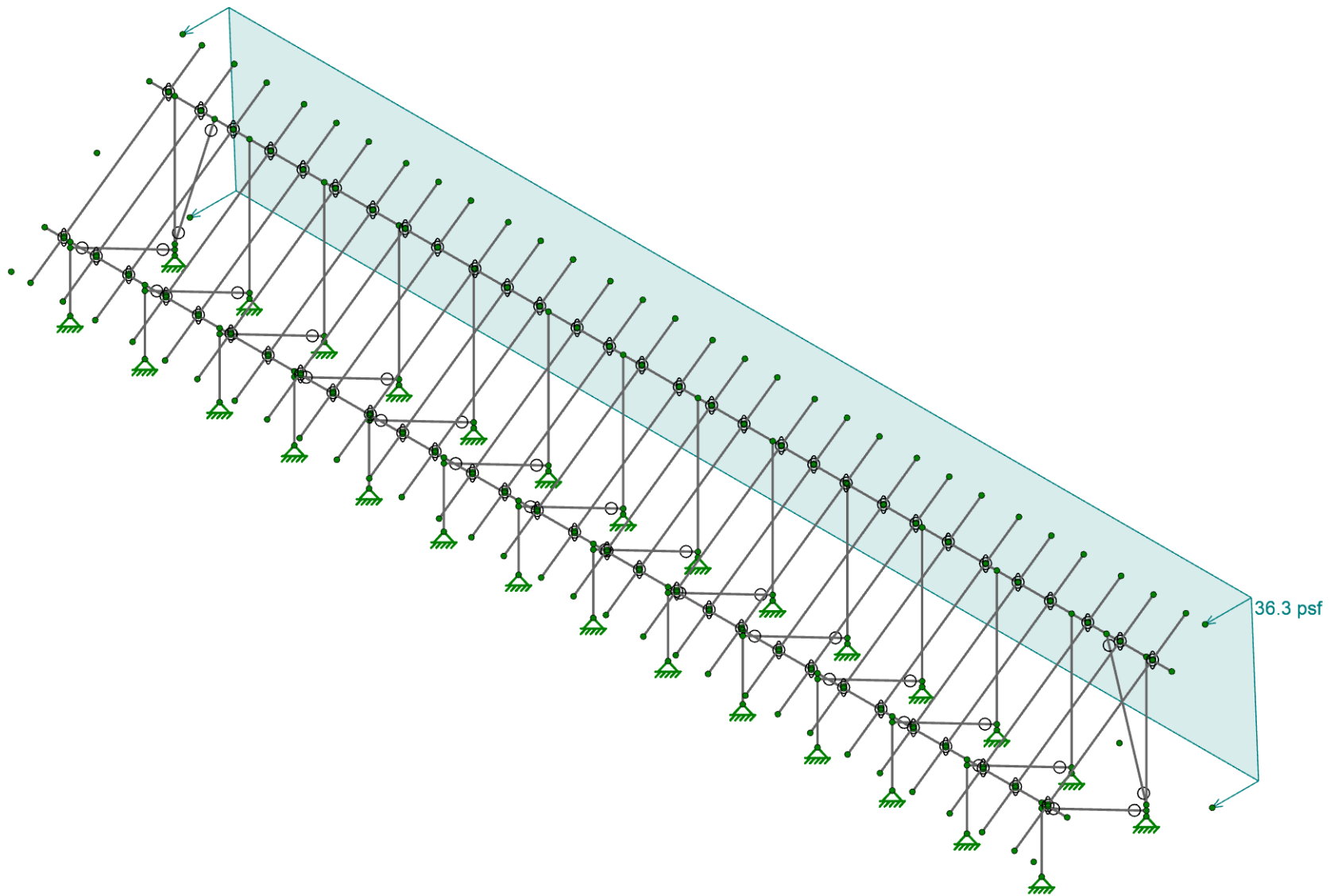
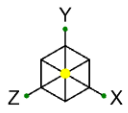

Loads: BLC 8, Wind Z



Vector Structural Engineering
CJT
U2716.0385.241

A16 Standard Panels - 35 Degree Tilt

SK-11
Mar 20, 2024
Sunturf A16 - SP - 35deg.r3d

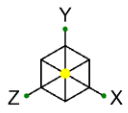

Code Check (Env)

- No Calc
- > 1.0
- .90-1.0
- .75-.90
- .50-.75
- 0-.50

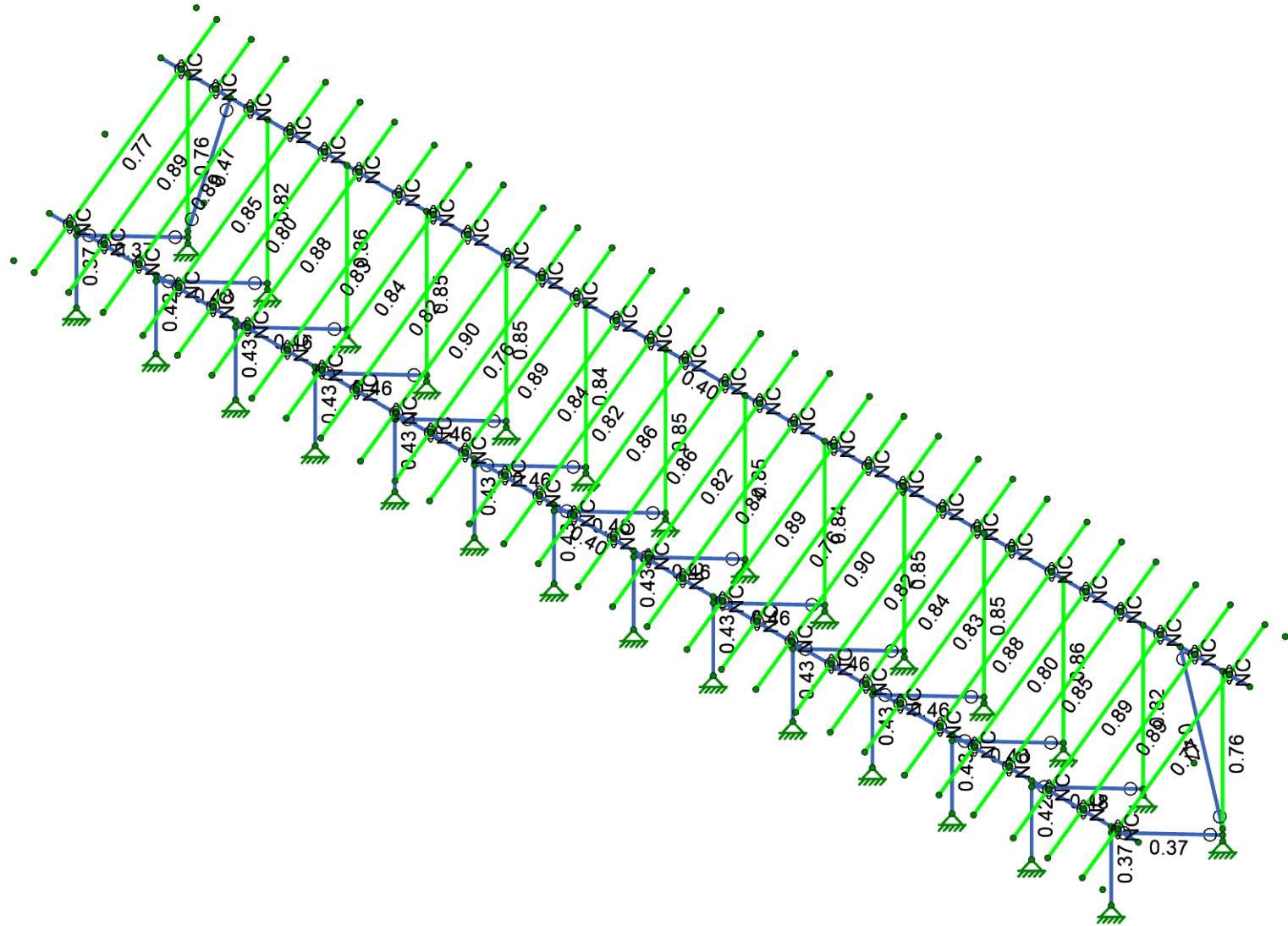

Member Code Checks Displayed (Enveloped)

 <p>IRISA A NEMETSCHKE COMPANY</p>	Vector Structural Engineering	A16 Standard Panels - 35 Degree Tilt	SK-12
	CJT		Mar 20, 2024
	U2716.0385.241		Sunturf A16 - SP - 35deg.r3d

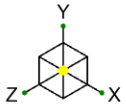

Shear Check
(Env)

- No Calc
- > 1.0
- .90-1.0
- .75-90
- .50-75
- 0-.50

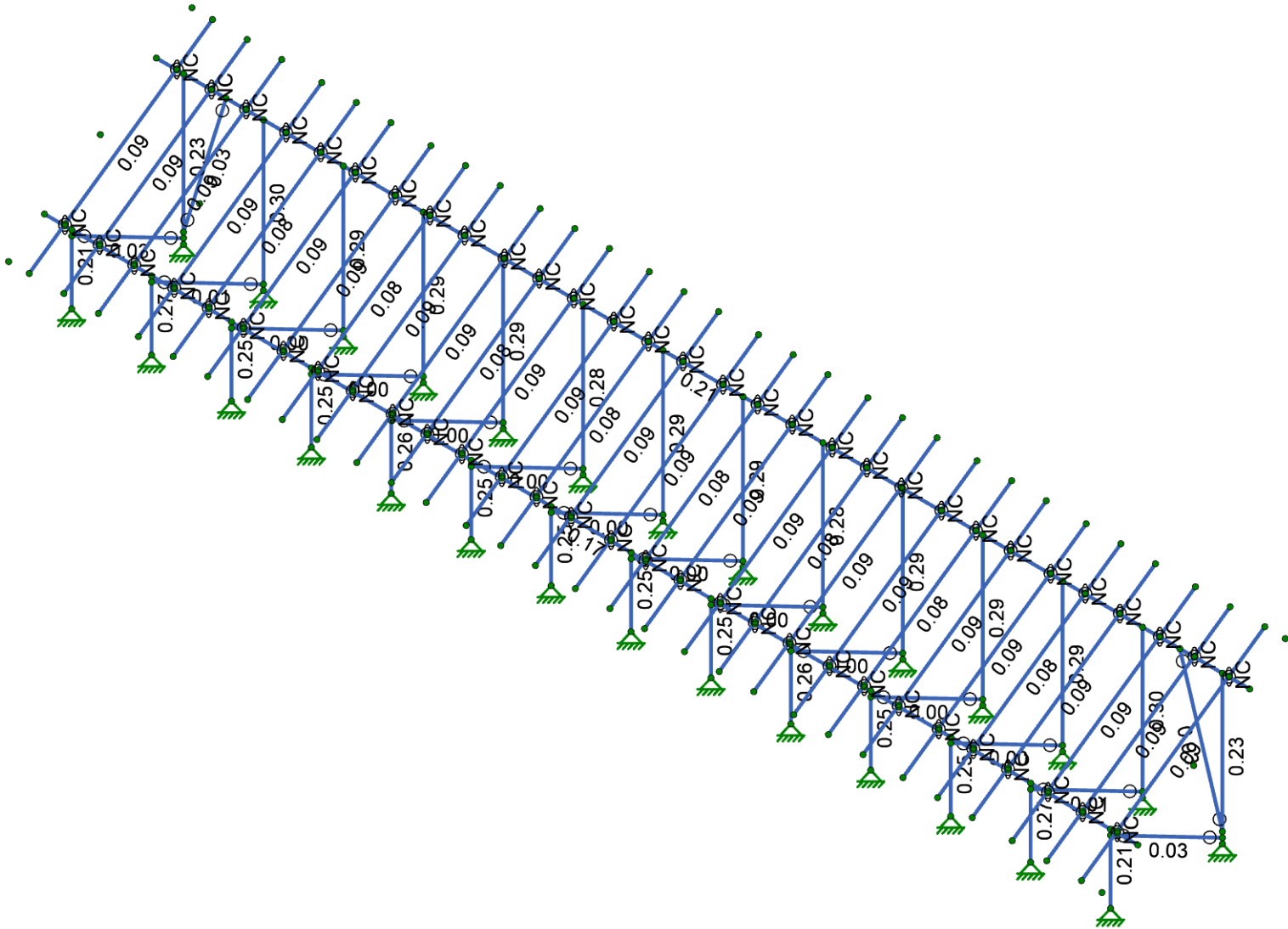

Member Shear Checks Displayed (Enveloped)



Vector Structural Engineering
CJT
U2716.0385.241

A16 Standard Panels - 35 Degree Tilt

SK-13
Mar 20, 2024
Sunturf A16 - SP - 35deg.r3d

Model Settings

Number of Reported Sections	5
Number of Internal Sections	100
Member Area Load Mesh Size (in ²)	144
Consider Shear Deformation	Yes
Consider Torsional Warping	Yes
Approximate Mesh Size (in)	24
Transfer Forces Between Intersecting Wood Walls	Yes
Increase Wood Wall Nailing Capacity for Wind Loads	Yes
Include P-Delta for Walls	Yes
Optimize Masonry and Wood Walls	Yes
Maximum Number of Iterations	3
Single	No
Multiple (Optimum)	Yes
Maximum	No

Global Axis corresponding to vertical direction	Y
Convert Existing Data	Yes
Default Global Plane for z-axis	XZ
Plate Local Axis Orientation	Nodal

Hot Rolled Steel	AISC 15th (360-16): ASD
Stiffness Adjustment	Yes (Iterative)
Notional Annex	None
Connections	None
Cold Formed Steel	None
Stiffness Adjustment	Yes (Iterative)
Wood	None
Temperature	< 100F
Concrete	ACI 318-19
Masonry	None
Aluminum	AA ADM1-20: ASD
Structure Type	Building
Stiffness Adjustment	Yes (Iterative)
Stainless	None
Stiffness Adjustment	Yes (Iterative)

Compression Stress Block	Rectangular Stress Block
Analyze using Cracked Sections	No
Leave room for horizontal rebar splices (2*d bar spacing)	Yes
List forces which were ignored for design in the Detail Report	Yes

Column Min Steel	1
Column Max Steel	8
Rebar Material Spec	ASTM A615
Warn if beam-column framing arrangement is not understood	No
Number of Shear Regions	4
Region 2 & 3 Spacing Increase Increment (in)	3.999992



Company : Vector Structural Engineering
Designer : CJT
Job Number : U2716.0385.241
Model Name : A16 Standard Panels - 35 Degre...

3/20/2024
3:33:22 PM
Checked By : MIH

Model Settings (Continued)

T Z (sec)	
T X (sec)	
C _Z	0.02
C _X	0.02
R Z	3
R X	3

Hot Rolled Steel Properties

	Label	E [ksi]	G [ksi]	Nu	Therm. Coeff. [1e ⁵ F ⁻¹]	Density [lb/ft ³]	Yield [psi]	Ry	Fu [psi]	Rt
1	A992	29000	11154	0.3	0.65	490	50000	1.1	65000	1.1
2	A36 Gr.36	29000	11154	0.3	0.65	490	36000	1.5	58000	1.2
3	A572 Gr.50	29000	11154	0.3	0.65	490	50000	1.1	65000	1.1
4	A500 Gr.B RND	29000	11154	0.3	0.65	527	42000	1.4	58000	1.3
5	A500 Gr.B Rect	29000	11154	0.3	0.65	527	46000	1.4	58000	1.3
6	A53 Gr.B	29000	11154	0.3	0.65	490	35000	1.6	60000	1.2
7	A1085	29000	11154	0.3	0.65	490	50000	1.4	65000	1.3

Aluminum Properties

	Label	E [ksi]	G [ksi]	Nu	Therm. Coeff. [1e ⁵ F ⁻¹]	Density [lb/ft ³]	Table B.4	kt	Ftu [psi]	Fty [psi]	Fcy [psi]	Fsu [psi]	Ct
1	3003-H14	10100	3787.5	0.33	1.3	172.8	Table B.4-1	1	19000	16000	13000	12000	141
2	6061-T6	10100	3787.5	0.33	1.3	172.8	Table B.4-2	1	38000	35000	35000	24000	141
3	6063-T5	10100	3787.5	0.33	1.3	172.8	Table B.4-2	1	22000	16000	16000	13000	141
4	6063-T6	10100	3787.5	0.33	1.3	172.8	Table B.4-2	1	30000	25000	25000	19000	141
5	5052-H34	10200	3787.5	0.33	1.3	172.8	Table B.4-1	1	34000	26000	24000	20000	141
6	6061-T6 W	10100	3787.5	0.33	1.3	172.8	Table B.4-1	1	24000	15000	15000	15000	141
7	6005-T5	10100	3787.5	0.33	1.3	172.8	Table B.4-1	1	38000	35000	35000	24000	141

Hot Rolled Steel Section Sets

	Label	Shape	Type	Design List	Material	Design Rule	Area [in ²]	Iyy [in ⁴]	Izz [in ⁴]	J [in ⁴]
1	Post	PIPE2.0A21165	Column	Pipe	A572 Gr.50	Typical	0.776	0.499	0.499	0.998
2	Cross Beam	PIPE2.5A21168	Beam	Wide Flange	A572 Gr.50	Typical	0.947	0.907	0.907	1.814
3	Diagonal Brace	1.5X1.5X0.083	HBrace	Square Tube	A572 Gr.50	Typical	0.47	0.158	0.158	0.236
4	Double Brace	3x1.5x0.083	HBrace	Tube	A572 Gr.50	Typical	0.719	0.283	0.845	0.654

Aluminum Section Sets

	Label	Shape	Type	Design List	Material	Design Rule	Area [in ²]	Iyy [in ⁴]	Izz [in ⁴]	J [in ⁴]
1	AL Posts	2.375ODX0.188	Column	Pipe	6005-T5	Typical	1.29	0.778	0.778	1.54
2	AL Brace	RT1.5X2X0.15625	VBrace	Rectangular Tubes	6005-T5	Typical	0.996	0.327	0.524	0.602
3	AL Rails	HR300 ALA	Beam	Rectangular Tubes	6005-T5	Typical	0.736	0.214	0.727	0.734
4	AL Cross Beam	CROSSRAIL	Beam	Rectangular Tubes	6005-T5	Typical	1.909	1.97	4.366	4.017

Basic Load Cases

	BLC Description	Category	Y Gravity	Distributed	Area(Member)
1	Self Weight	DL	-1.05		
2	Solar Panel Weight	DL			1
3	Roof Live/Snow	RLL			1
4	Wind A 0 deg	OL1			2
5	Wind B 0 deg	OL2			2
6	Wind A 180 deg	OL3			2
7	Wind B 180 deg	OL4			2
8	Wind Z	WLZ			1
9	BLC 2 Transient Area Loads	None		50	
10	BLC 3 Transient Area Loads	None		50	
11	BLC 4 Transient Area Loads	None		184	
12	BLC 5 Transient Area Loads	None		184	
13	BLC 6 Transient Area Loads	None		184	
14	BLC 7 Transient Area Loads	None		184	
15	BLC 8 Transient Area Loads	None		120	

Member Area Loads (BLC 2 : Solar Panel Weight)

Node A	Node B	Node C	Node D	Direction	Load	Direction	A Magnitude [psf]	B Magnitude [psf]	C Magnitude [psf]	D Magnitude [psf]	Exclude Braces
1	N197	N200	N199	N196	Y	A-B	-3	-3	-3	-3	Yes

Member Area Loads (BLC 3 : Roof Live/Snow)

Node A	Node B	Node C	Node D	Direction	Load	Direction	A Magnitude [psf]	B Magnitude [psf]	C Magnitude [psf]	D Magnitude [psf]	Exclude Braces
1	N197	N200	N199	N196	PY	A-B	-53	-53	-53	-53	Yes

Member Area Loads (BLC 4 : Wind A 0 deg)

Node A	Node B	Node C	Node D	Direction	Load	Direction	A Magnitude [psf]	B Magnitude [psf]	C Magnitude [psf]	D Magnitude [psf]	Exclude Braces
1	N197	N200	N201	N198	Perp	A-B	-55.5	-55.5	-55.5	-55.5	Yes
2	N198	N201	N199	N196	Perp	A-B	-55.5	-55.5	-55.5	-55.5	Yes

Member Area Loads (BLC 5 : Wind B 0 deg)

Node A	Node B	Node C	Node D	Direction	Load	Direction	A Magnitude [psf]	B Magnitude [psf]	C Magnitude [psf]	D Magnitude [psf]	Exclude Braces
1	N197	N200	N201	N198	Perp	A-B	-74.1	-74.1	-74.1	-74.1	Yes
2	N198	N201	N199	N196	Perp	A-B	-18.5	-18.5	-18.5	-18.5	Yes

Member Area Loads (BLC 6 : Wind A 180 deg)

Node A	Node B	Node C	Node D	Direction	Load	Direction	A Magnitude [psf]	B Magnitude [psf]	C Magnitude [psf]	D Magnitude [psf]	Exclude Braces
1	N197	N200	N201	N198	Perp	A-B	64.8	64.8	64.8	64.8	Yes
2	N198	N201	N199	N196	Perp	A-B	64.8	64.8	64.8	64.8	Yes

Member Area Loads (BLC 7 : Wind B 180 deg)

Node A	Node B	Node C	Node D	Direction	Load	Direction	A Magnitude [psf]	B Magnitude [psf]	C Magnitude [psf]	D Magnitude [psf]	Exclude Braces
1	N197	N200	N201	N198	Perp	A-B	33.9	33.9	33.9	33.9	Yes
2	N198	N201	N199	N196	Perp	A-B	83.3	83.3	83.3	83.3	Yes

Member Area Loads (BLC 8 : Wind Z)

Node A	Node B	Node C	Node D	Direction	Load	Direction	A Magnitude [psf]	B Magnitude [psf]	C Magnitude [psf]	D Magnitude [psf]	Exclude Braces
1	N200	N197	N307	N308	Z	Open Structure	36.3	36.3	36.3	36.3	Yes

Load Combinations

	Description	Solve	P-Delta	BLC	Factor	BLC	Factor	BLC	Factor	BLC	Factor
1	ASD Loads		Y								
2	1.0 D	Yes	Y	DL	1						
3	1.0 D + 1.0 S	Yes	Y	DL	1	RLL	1				
4	1.0 D + 0.6 W1	Yes	Y	DL	1	RLL		OL1	0.6	WLZ	0.6
5	1.0 D + 0.6 W2	Yes	Y	DL	1	RLL		OL2	0.6	WLZ	0.6
6	1.0 D + 0.6 W3	Yes	Y	DL	1	RLL		OL3	0.6	WLZ	-0.6
7	1.0 D + 0.6 W4	Yes	Y	DL	1	RLL		OL4	0.6	WLZ	-0.6
8	1.0 D + 0.45 W1 + 0.75 S	Yes	Y	DL	1	RLL	0.75	OL1	0.45	WLZ	0.45
9	1.0 D + 0.45 W2 + 0.75 S	Yes	Y	DL	1	RLL	0.75	OL2	0.45	WLZ	0.45
10	1.0 D + 0.45 W3 + 0.75 S	Yes	Y	DL	1	RLL	0.75	OL3	0.45	WLZ	-0.45
11	1.0 D + 0.45 W4 + 0.75 S	Yes	Y	DL	1	RLL	0.75	OL4	0.45	WLZ	-0.45
12	0.6 D + 0.6 W1	Yes	Y	DL	0.6	RLL		OL1	0.6	WLZ	0.6
13	0.6 D + 0.6 W2	Yes	Y	DL	0.6	RLL		OL2	0.6	WLZ	0.6

Load Combinations (Continued)

	Description	Solve	P-Delta	BLC	Factor	BLC	Factor	BLC	Factor	BLC	Factor
14	0.6 D + 0.6 W3	Yes	Y	DL	0.6	RLL		OL3	0.6	WLZ	-0.6
15	0.6 D + 0.6 W4	Yes	Y	DL	0.6	RLL		OL4	0.6	WLZ	-0.6
16			Y								
17	LRFD Loads		Y								
18	1.4 D		Y	DL	1.4	RLL					
19	1.2 D + 1.6 S + 0.5 W1		Y	DL	1.2	RLL	1.6	OL1	0.5		
20	1.2 D + 1.6 S + 0.5 W2		Y	DL	1.2	RLL	1.6	OL2	0.5		
21	1.2 D + 1.6 S + 0.5 W3		Y	DL	1.2	RLL	1.6	OL3	0.5		
22	1.2 D + 1.6 S + 0.5 W4		Y	DL	1.2	RLL	1.6	OL4	0.5		
23	1.2 D + 1.0 W1		Y	DL	1.2	RLL		OL1	1		
24	1.2 D + 1.0 W2		Y	DL	1.2	RLL		OL2	1		
25	1.2 D + 1.0 W3		Y	DL	1.2	RLL		OL3	1		
26	1.2 D + 1.0 W4		Y	DL	1.2	RLL		OL4	1		
27	0.9 D + 1.0 W1		Y	DL	0.9	RLL		OL1	1		
28	0.9 D + 1.0 W2		Y	DL	0.9	RLL		OL2	1		
29	0.9 D + 1.0 W3		Y	DL	0.9	RLL		OL3	1		
30	0.9 D + 1.0 W4		Y	DL	0.9	RLL		OL4	1		

Envelope Node Reactions

	Node Label	X [lb]	LC	Y [lb]	LC	Z [lb]	LC	MX [lb-ft]	LC	MY [lb-ft]	LC	MZ [lb-ft]	LC	
1	N239	max	1.246	13	3479.79	10	1852.577	6	0	15	0	15	0	15
2		min	-1.801	10	-2553.417	13	-1613.674	4	0	2	0	2	0	2
3	N461	max	1.833	10	3480.421	10	1852.531	6	0	15	0	15	0	15
4		min	-1.251	13	-2553.36	13	-1613.662	4	0	2	0	2	0	2
5	N449	max	0.918	13	3407.439	10	1865.509	6	0	15	0	15	0	15
6		min	-1.625	10	-2503.852	13	-1622.393	4	0	2	0	2	0	2
7	N251	max	1.641	10	3407.378	10	1865.524	6	0	15	0	15	0	15
8		min	-0.923	13	-2503.835	13	-1622.404	4	0	2	0	2	0	2
9	N269	max	1.178	10	3408.885	10	1860.088	6	0	15	0	15	0	15
10		min	-0.747	13	-2498.941	13	-1617.146	4	0	2	0	2	0	2
11	N263	max	0.741	13	3408.865	10	1860.087	6	0	15	0	15	0	15
12		min	-1.162	10	-2498.929	13	-1617.145	4	0	2	0	2	0	2
13	N455	max	0.991	13	3382.376	10	1853.811	6	0	15	0	15	0	15
14		min	-1.629	10	-2473.743	13	-1610.367	4	0	2	0	2	0	2
15	N245	max	1.641	10	3382.472	10	1853.798	6	0	15	0	15	0	15
16		min	-0.997	13	-2473.73	13	-1610.367	4	0	2	0	2	0	2
17	N275	max	1.994	10	3376.878	10	1843.692	6	0	15	0	15	0	15
18		min	-1.342	13	-2468.505	13	-1602.611	4	0	2	0	2	0	2
19	N257	max	1.336	13	3376.837	10	1843.676	6	0	15	0	15	0	15
20		min	-1.979	10	-2468.467	13	-1602.598	4	0	2	0	2	0	2
21	N151	max	160.336	13	3241.671	10	1486.384	6	0	15	0	15	0	15
22		min	-252.57	10	-2310.828	13	-1295.463	4	0	2	0	2	0	2
23	N1	max	252.762	10	3246.907	10	1486.43	6	0	15	0	15	0	15
24		min	-160.314	13	-2310.568	13	-1295.489	4	0	2	0	2	0	2
25	N421	max	4.265	13	2961.309	10	1939.773	6	0	15	0	15	0	15
26		min	-6.52	10	-2215.403	13	-1681.835	4	0	2	0	2	0	2
27	N276	max	6.454	10	2965.262	10	1939.779	6	0	15	0	15	0	15
28		min	-4.272	13	-2215.315	13	-1681.868	4	0	2	0	2	0	2
29	N241	max	1.964	13	2062.871	9	119.706	4	0	15	0	15	0	15
30		min	-1.793	6	-471.145	14	-137.698	6	0	2	0	2	0	2
31	N463	max	1.791	6	2062.274	9	119.705	4	0	15	0	15	0	15
32		min	-1.963	13	-471.106	14	-137.697	6	0	2	0	2	0	2
33	N278	max	1.185	12	2132.865	9	117.918	4	0	15	0	15	0	15
34		min	-6.917	11	-467.899	14	-135.824	6	0	2	0	2	0	2
35	N423	max	7.149	11	2136.538	9	117.919	4	0	15	0	15	0	15

Envelope Node Reactions (Continued)

Node Label		X [lb]	LC	Y [lb]	LC	Z [lb]	LC	MX [lb-ft]	LC	MY [lb-ft]	LC	MZ [lb-ft]	LC
36		min	12	-1.17	12	-467.653	14	-135.826	6	0	2	0	2
37	N253	max	11	4	11	2062.566	9	120.55	4	0	15	0	15
38		min	12	-0.465	12	-466.554	14	-138.809	6	0	2	0	2
39	N451	max	12	0.468	12	2062.538	9	120.549	4	0	15	0	15
40		min	11	-3.979	11	-466.545	14	-138.809	6	0	2	0	2
41	N271	max	9	2.569	9	2065.692	9	120.323	4	0	15	0	15
42		min	14	0.031	14	-458.914	14	-138.663	6	0	2	0	2
43	N265	max	14	-0.031	14	2065.694	9	120.323	4	0	15	0	15
44		min	9	-2.502	9	-458.91	14	-138.663	6	0	2	0	2
45	N247	max	9	3.389	9	2052.301	9	120.045	4	0	15	0	15
46		min	14	-1.034	14	-444.248	14	-138.496	6	0	2	0	2
47	N457	max	14	1.034	14	2052.396	9	120.045	4	0	15	0	15
48		min	9	-3.314	9	-444.248	14	-138.496	6	0	2	0	2
49	N445	max	9	5.015	9	2039.467	9	119.847	4	0	15	0	15
50		min	14	-0.554	14	-441.491	14	-138.298	6	0	2	0	2
51	N259	max	14	0.554	14	2039.452	9	119.846	4	0	15	0	15
52		min	9	-4.946	9	-441.457	14	-138.297	6	0	2	0	2
53	N2	max	11	37.608	11	1655.089	9	102.926	4	0	15	0	15
54		min	12	-13.381	12	-358.723	14	-119.323	6	0	2	0	2
55	N152	max	12	13.36	12	1660.419	9	102.924	4	0	15	0	15
56		min	11	-38.041	11	-358.371	14	-119.321	6	0	2	0	2
57	Totals:	max	10	0.001	10	58624.518	10	23509.445	14				
58		min	12	0	12	-23384.558	12	-20444.397	4				

Envelope AISC 15TH (360-16): ASD Member Steel Code Checks

Member	Shape	Code Check	Loc[in]	LC	Shear Check	Loc[in]	LC	DirLC	Pnc/om [lb]	Pnt/om [lb]	Mnyy/om [lb-ft]	Mnzz/om [lb-ft]	Cb	Eqn
1	M5	PIPE2.0A21165	0.374	47.233	14	0.208	47.77	6	17180.649	23232.186	1397.505	1397.505	1	H1-1b
2	M6	PIPE2.0A21165	0.762	3.468	10	0.23	0	6	6091.968	23232.186	1397.505	1397.505	1	H1-1a
3	M15	3x1.5x0.083	0.371	50.26	6	0.03	94.608	y 10	4754.191	21540.24	952.46	1737.715	1.136	H1-1a
4	M19	1.5X1.5X0.083	0.469	67.399	10	0.029	107.838	y 6	2041.834	14085.15	624.421	624.421	1.136	H1-1a
5	M73	PIPE2.0A21165	0.374	47.233	14	0.208	47.77	6	17180.649	23232.186	1397.505	1397.505	1	H1-1b
6	M74	PIPE2.0A21165	0.761	3.468	10	0.23	0	6	6091.968	23232.186	1397.505	1397.505	1	H1-1a
7	M75	3x1.5x0.083	0.371	50.26	6	0.03	94.608	y 10	4754.225	21540.24	952.46	1737.715	1.136	H1-1a
8	M75B	1.5X1.5X0.083	0.469	67.399	10	0.029	107.838	y 6	2041.834	14085.15	624.421	624.421	1.136	H1-1a
9	M71	PIPE2.5A21168	0.405	684.067	10	0.211	615.66	10	20336.2	28358.413	2081.747	2081.747	1	H1-1b
10	M72	PIPE2.5A21168	0.396	743.923	11	0.172	743.923	11	20336.2	28358.413	2081.747	2081.747	1	H1-1b
11	M134	PIPE2.0A21165	0.819	3.468	6	0.297	0	6	6091.968	23232.186	1397.505	1397.505	1	H1-1a
12	M135	3x1.5x0.083	0.483	50.26	6	0.008	94.608	y 10	4754.225	21540.24	952.46	1737.715	1.136	H1-1a
13	M136	PIPE2.0A21165	0.422	47.233	14	0.269	47.77	6	17180.649	23232.186	1397.505	1397.505	1	H1-1b
14	M116	PIPE2.0A21165	0.861	3.468	6	0.286	0	6	6091.968	23232.186	1397.505	1397.505	1	H1-1a
15	M117	3x1.5x0.083	0.462	50.26	6	0.005	94.608	y 10	4754.225	21540.24	952.46	1737.715	1.136	H1-1a
16	M118	PIPE2.0A21165	0.427	47.233	14	0.255	47.77	6	17180.649	23232.186	1397.505	1397.505	1	H1-1b
17	M119	PIPE2.0A21165	0.847	3.468	6	0.286	0	6	6091.968	23232.186	1397.505	1397.505	1	H1-1a
18	M120	3x1.5x0.083	0.462	50.26	6	0.003	94.608	y 9	4754.225	21540.24	952.46	1737.715	1.136	H1-1a
19	M121	PIPE2.0A21165	0.428	47.233	14	0.254	47.77	6	17180.649	23232.186	1397.505	1397.505	1	H1-1b
20	M122	PIPE2.0A21165	0.855	3.468	6	0.287	0	6	6091.968	23232.186	1397.505	1397.505	1	H1-1a
21	M123	3x1.5x0.083	0.465	50.26	6	0.002	94.608	y 3	4754.225	21540.24	952.46	1737.715	1.136	H1-1a
22	M124	PIPE2.0A21165	0.43	47.233	14	0.255	47.77	6	17180.649	23232.186	1397.505	1397.505	1	H1-1b
23	M125	PIPE2.0A21165	0.845	3.468	6	0.284	0	6	6091.968	23232.186	1397.505	1397.505	1	H1-1a
24	M126	3x1.5x0.083	0.459	50.26	6	0.004	94.608	y 9	4754.225	21540.24	952.46	1737.715	1.136	H1-1a
25	M127	PIPE2.0A21165	0.427	47.233	14	0.253	47.77	6	17180.649	23232.186	1397.505	1397.505	1	H1-1b
26	M128	PIPE2.0A21165	0.853	3.468	6	0.287	0	6	6091.968	23232.186	1397.505	1397.505	1	H1-1a
27	M129	3x1.5x0.083	0.464	50.26	6	0.002	94.608	y 9	4754.225	21540.24	952.46	1737.715	1.136	H1-1a
28	M130	PIPE2.0A21165	0.429	47.233	14	0.255	47.77	6	17180.649	23232.186	1397.505	1397.505	1	H1-1b
29	M131	PIPE2.0A21165	0.853	3.468	6	0.287	0	6	6091.968	23232.186	1397.505	1397.505	1	H1-1a

Envelope AISC 15TH (360-16): ASD Member Steel Code Checks (Continued)

Member	Shape	Code Check	Loc[in]	LC	Shear	Check	Loc[in]	Dir	LC	Pnc/om [lb]	Pnt/om [lb]	Mnyy/om [lb-ft]	Mnzz/om [lb-ft]	Cb	Eqn
30	M132	3x1.5x0.083	0.464	50.26	6	0.002	94.608	y	9	4754.225	21540.24	952.46	1737.715	1.136	H1-1a
31	M217	PIPE2.0A21165	0.429	47.233	14	0.255	47.77		6	17180.649	23232.186	1397.505	1397.505	1	H1-1b
32	M218	PIPE2.0A21165	0.845	3.468	6	0.284	0		6	6091.968	23232.186	1397.505	1397.505	1	H1-1a
33	M219	3x1.5x0.083	0.459	50.26	6	0.004	94.608	y	9	4754.225	21540.24	952.46	1737.715	1.136	H1-1a
34	M220	PIPE2.0A21165	0.427	47.233	14	0.253	47.77		6	17180.649	23232.186	1397.505	1397.505	1	H1-1b
35	M221	PIPE2.0A21165	0.855	3.468	6	0.287	0		6	6091.968	23232.186	1397.505	1397.505	1	H1-1a
36	M222	3x1.5x0.083	0.465	50.26	6	0.003	94.608	y	3	4754.225	21540.24	952.46	1737.715	1.136	H1-1a
37	M223	PIPE2.0A21165	0.43	47.233	14	0.255	47.77		6	17180.649	23232.186	1397.505	1397.505	1	H1-1b
38	M224	PIPE2.0A21165	0.847	3.468	6	0.286	0		6	6091.968	23232.186	1397.505	1397.505	1	H1-1a
39	M225	3x1.5x0.083	0.462	50.26	6	0.003	94.608	y	9	4754.225	21540.24	952.46	1737.715	1.136	H1-1a
40	M226	PIPE2.0A21165	0.428	47.233	14	0.254	47.77		6	17180.649	23232.186	1397.505	1397.505	1	H1-1b
41	M227	PIPE2.0A21165	0.861	3.468	6	0.286	0		6	6091.968	23232.186	1397.505	1397.505	1	H1-1a
42	M228	3x1.5x0.083	0.462	50.26	6	0.005	94.608	y	10	4754.225	21540.24	952.46	1737.715	1.136	H1-1a
43	M229	PIPE2.0A21165	0.427	47.233	14	0.255	47.77		6	17180.649	23232.186	1397.505	1397.505	1	H1-1b
44	M205	PIPE2.0A21165	0.819	3.468	6	0.297	0		6	6091.968	23232.186	1397.505	1397.505	1	H1-1a
45	M206	3x1.5x0.083	0.483	50.26	6	0.008	94.608	y	10	4754.225	21540.24	952.46	1737.715	1.136	H1-1a
46	M207	PIPE2.0A21165	0.422	47.233	14	0.269	47.77		6	17180.649	23232.186	1397.505	1397.505	1	H1-1b

Envelope AA ADM1-20: ASD - BUILDING Member Aluminum Code Checks

Member	Shape	Code Check	Loc[in]	LC	Shear	Check	Loc[in]	Dir	LC	Pnc/Om [lb]	Pnt/Om [lb]	Mny/Om [lb-ft]	Mnz/Om [lb-ft]	Vny/Om [lb]	Vnz/Om [lb]	Cb	Eqn
1	M107	HR300_ALA	0.77	84	10	0.088	33.25	y	11	3550.267	14342.564	533.921	934.619	7307.692	3206.154	1.403	H.1-1
2	M62	HR300_ALA	0.893	84	10	0.091	33.25	y	11	3550.267	14342.564	533.921	934.619	7307.692	3206.154	1.413	H.1-1
3	M65	HR300_ALA	0.889	84	10	0.092	33.25	y	11	3550.267	14342.564	533.921	934.619	7307.692	3206.154	1.41	H.1-1
4	M68	HR300_ALA	0.851	84	10	0.087	33.25	y	11	3550.267	14342.564	533.921	934.619	7307.692	3206.154	1.408	H.1-1
5	M76	HR300_ALA	0.797	84	10	0.081	33.25	y	11	3550.267	14342.564	533.921	934.619	7307.692	3206.154	1.409	H.1-1
6	M79	HR300_ALA	0.881	84	10	0.086	33.25	y	11	3550.267	14342.564	533.921	934.619	7307.692	3206.154	1.41	H.1-1
7	M82	HR300_ALA	0.834	84	10	0.086	33.25	y	11	3550.267	14342.564	533.921	934.619	7307.692	3206.154	1.408	H.1-1
8	M133	HR300_ALA	0.836	84	10	0.079	33.25	y	11	3550.267	14342.564	533.921	934.619	7307.692	3206.154	1.41	H.1-1
9	M139	HR300_ALA	0.819	84	10	0.086	33.25	y	11	3550.267	14342.564	533.921	934.619	7307.692	3206.154	1.407	H.1-1
10	M142	HR300_ALA	0.9	84	10	0.085	33.25	y	11	3550.267	14342.564	533.921	934.619	7307.692	3206.154	1.41	H.1-1
11	M145	HR300_ALA	0.759	84	10	0.08	33.25	y	11	3550.267	14342.564	533.921	934.619	7307.692	3206.154	1.407	H.1-1
12	M148	HR300_ALA	0.892	84	10	0.085	33.25	y	11	3550.267	14342.564	533.921	934.619	7307.692	3206.154	1.41	H.1-1
13	M151	HR300_ALA	0.838	84	10	0.086	33.25	y	11	3550.267	14342.564	533.921	934.619	7307.692	3206.154	1.408	H.1-1
14	M154	HR300_ALA	0.818	84	10	0.079	33.25	y	11	3550.267	14342.564	533.921	934.619	7307.692	3206.154	1.41	H.1-1
15	M157	HR300_ALA	0.857	84	10	0.086	33.25	y	11	3550.267	14342.564	533.921	934.619	7307.692	3206.154	1.409	H.1-1
16	M160	HR300_ALA	0.857	84	10	0.086	33.25	y	11	3550.267	14342.564	533.921	934.619	7307.692	3206.154	1.409	H.1-1
17	M163	HR300_ALA	0.818	84	10	0.079	33.25	y	11	3550.267	14342.564	533.921	934.619	7307.692	3206.154	1.41	H.1-1
18	M166	HR300_ALA	0.838	84	10	0.086	33.25	y	11	3550.267	14342.564	533.921	934.619	7307.692	3206.154	1.408	H.1-1
19	M169	HR300_ALA	0.892	84	10	0.085	33.25	y	11	3550.267	14342.564	533.921	934.619	7307.692	3206.154	1.41	H.1-1
20	M172	HR300_ALA	0.759	84	10	0.08	33.25	y	11	3550.267	14342.564	533.921	934.619	7307.692	3206.154	1.407	H.1-1
21	M175	HR300_ALA	0.9	84	10	0.085	33.25	y	11	3550.267	14342.564	533.921	934.619	7307.692	3206.154	1.41	H.1-1
22	M178	HR300_ALA	0.819	84	10	0.086	33.25	y	11	3550.267	14342.564	533.921	934.619	7307.692	3206.154	1.407	H.1-1
23	M181	HR300_ALA	0.836	84	10	0.079	33.25	y	11	3550.267	14342.564	533.921	934.619	7307.692	3206.154	1.41	H.1-1
24	M184	HR300_ALA	0.834	84	10	0.086	33.25	y	11	3550.267	14342.564	533.921	934.619	7307.692	3206.154	1.408	H.1-1
25	M187	HR300_ALA	0.881	84	10	0.086	33.25	y	11	3550.267	14342.564	533.921	934.619	7307.692	3206.154	1.41	H.1-1
26	M190	HR300_ALA	0.797	84	10	0.081	33.25	y	11	3550.267	14342.564	533.921	934.619	7307.692	3206.154	1.409	H.1-1
27	M193	HR300_ALA	0.851	84	10	0.087	33.25	y	11	3550.267	14342.564	533.921	934.619	7307.692	3206.154	1.408	H.1-1
28	M196	HR300_ALA	0.889	84	10	0.092	33.25	y	11	3550.267	14342.564	533.921	934.619	7307.692	3206.154	1.41	H.1-1
29	M199	HR300_ALA	0.894	84	10	0.092	33.25	y	11	3550.267	14342.564	533.921	934.619	7307.692	3206.154	1.413	H.1-1
30	M202	HR300_ALA	0.77	84	10	0.089	33.25	y	11	3550.267	14342.564	533.921	934.619	7307.692	3206.154	1.403	H.1-1



JOB NO.: U2716.0385.241

PROJECT: SunTurf Package A16

SUBJECT: CALCULATIONS

DESIGN APPROACH ASD

CONNECTION CAPACITY

Location: Column Base (set screws)

Connection Type: M16 Conical Set Screws

Tensile Capacity: 2600 lbs

Tension Load: 2554 lbs

Check Connection: 98.2%

Result: **Select M16 Conical Set Screws**

Note: Uplift capacity. FOS of (2)

CONNECTION CAPACITY

Location: Column to Cross Beam

Connection Type: K10341-002

Tensile Capacity: 2195 lbs

Tension Load: 1850 lbs

Check Connection: 84.3%

Result: **Select K10341-002**

Note: Uplift capacity. FOS of (2)



JOB NO.: U2716.0385.241

PROJECT: SunTurf Package A16

SUBJECT: CALCULATIONS

CONNECTION CAPACITY

Location: Brace to Column

Connection Type: K10219-001

Capacity: 3118 lbs

Tension Load: 2260 lbs

Check Connection: 72.5%

Result: **Select K10219-001**

Note: Axial capacity. FOS of (2)

BOLTED TENSION CONNECTION

Location: Rail to Cross Beam

Bolt Grade: A304 SS (A2-70)

Bolt Diameter: 0.375 in

Number of Bolts: 2

Bolt Capacity: 8410 lbs (AISC Equation J3-1)

Tension Load: 1108 lbs

Check Bolt: 13.2%

Result: **Select (2) 0.375 in. dia. A304 SS (A2-70) bolts.**

Note:



JOB NO.: U2716.0385.241

PROJECT: Sunturf Package A16 Ground Mount

SNOW LOADS

ALTERNATE FOUNDATION OPTION 1: DRILLED CONCRETE PIER



PROJECT: Sunturf Package A16 Ground Mount

DRILLED CONCRETE PIER DESIGN

Column Reactions:

Max. Shear, V [k]:	1.9	Max. Down, P _d [k]:	3.6
Max. Moment, M [k-ft]:	0.0	Max. Uplift, P _u [k]:	2.6

Pier Properties:

Pier Shape:	Round	Volume of Concrete [ft ³]:	16
Pier Diameter, b [ft]:	2.0	Volume of Concrete [yd ³]:	0.6
Top of Pier Elevation [ft]:	0.00	Weight of Concrete [k]:	2.4
Pier Depth, d [ft]:	5.0		

Soil Properties:

Allow. Bearing Pressure [psf]:	1,500	<u>Optional Parameters for Uplift:</u>	
1/3 increase for short term loads?	No	Skin Friction* [psf]:	250
Lateral Bearing, S [pcf]:	150	Top Length to Ignore [ft]:	0
Max. Lateral Bearing (opt'l) [psf]:		1/3 increase for short term loads?	No
Top Depth to Ignore [ft]:	0	Combine w/ Bearing:	No
1/3 increase for short term loads?	No		
1/2" deflection at t/o pier allowed:	Yes		

*per IBC Section 1810.3.3.1.4

Check Bearing:

Bearing Capacity [k]:	7.9
-----------------------	-----

Bearing capacity OK.

Check Uplift:

Uplift Capacity [k]:	10.0
----------------------	------

Uplift capacity OK.

Check Lateral Bearing:

Top of Pier Constrained?:	No	IBC Section 1807.3.2.1
Applied Lateral Force, P [lb]:	1,940	
Point of Application, h [ft]:	0.0	
S _{max} [psf]:		
S [psf]:	500	
A = 2.34*P/(S _b):	4.54	
Required Pier Depth, d _{reqd} [ft]:	4.50	IBC Eq. 18-1

Result: **Lateral bearing capacity OK.**



JOB NO.: U2716.0385.241

PROJECT: Sunturf Package A16 Ground Mount

ALTERNATE FOUNDATION OPTION 2: CONCRETE BALLAST BLOCK

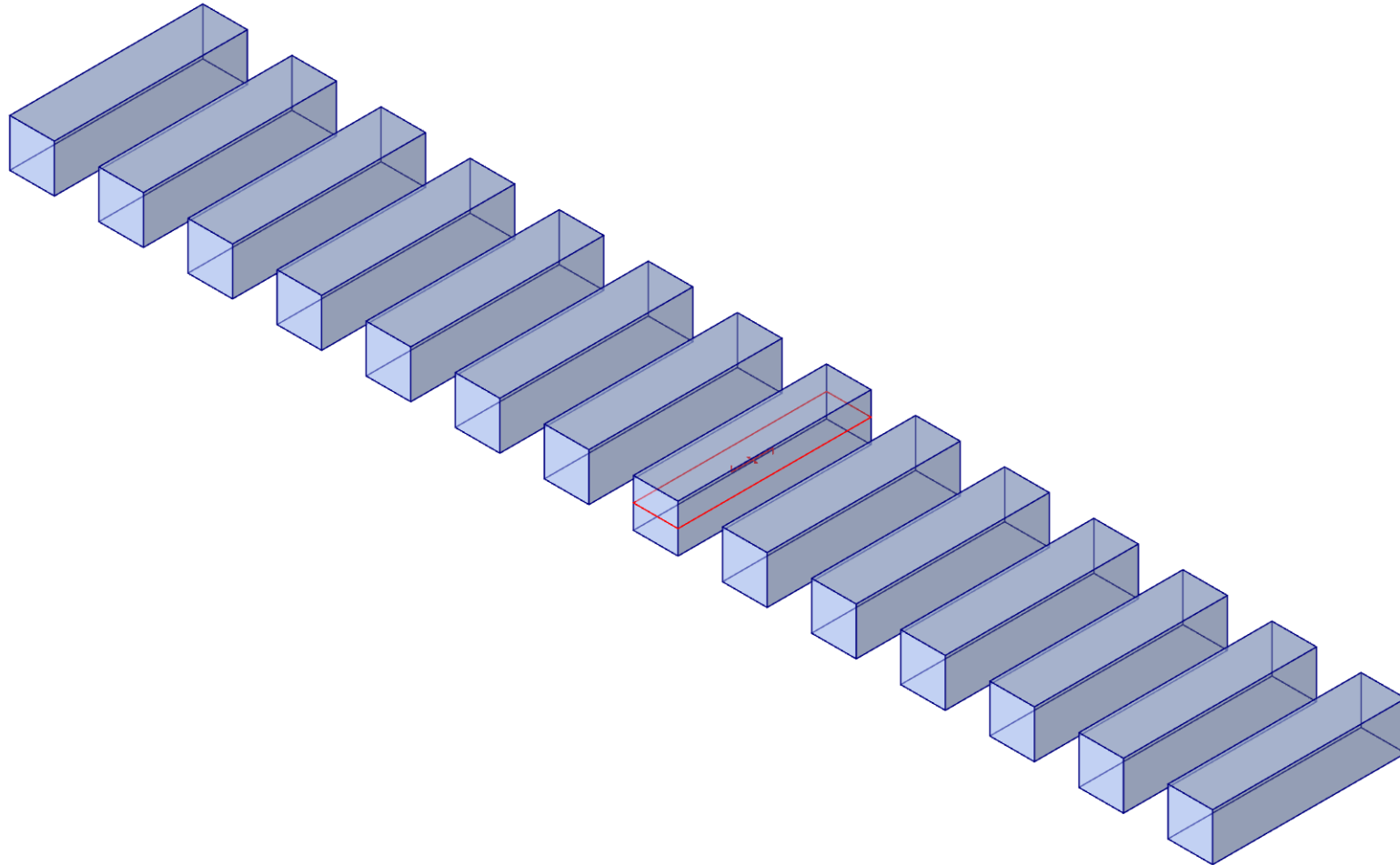

Vector Structural Engineering
CJT
U2716.0385.241

Ground Mount

SK-1
Mar 20, 2024
Sunturf A16 - SP - 35deg.r3d

Concrete Properties

Label	E [ksi]	G [ksi]	Nu	Therm. Coeff. [$1e^{-5}F^{-1}$]	Density [lb/ft ³]	f _c [psi]	Lambda	Flex Steel [psi]	Shear Steel [psi]
1 Conc3000NW	3156	1372	0.15	0.6	145	3000	1	60000	60000
2 Conc3500NW	3409	1482	0.15	0.6	145	3500	1	60000	60000
3 Conc4000NW	3644	1584	0.15	0.6	145	4000	1	60000	60000
4 Conc3000LW	2085	907	0.15	0.6	109.999	3000	0.75	60000	60000
5 Conc3500LW	2252	979	0.15	0.6	109.999	3500	0.75	60000	60000
6 Conc4000LW	2408	1047	0.15	0.6	109.999	4000	0.75	60000	60000
7 Conc2500NW	3156	1372	0.15	0.6	145	2500	1	60000	60000

Design Rules - Mat Slab

Label	Max Bending Chk	Max Shear Chk	Top Bar	Bottom Bar	Min Top Bar Spacing [in]	Max Top Bar Spacing [in]	Min Bot Bar Spacing [in]	Max Bot Bar Spacing [in]	Spacing Increment [in]	Top Cover [in]	Bottom Cover [in]	Side Cover [in]	Rebar Options
1 Typical	1	1	#5	#5	3	12	3	12	1	3	3	0	Optimize

Soil Definitions

Label	Layers	Subgrade Modulus [lb/ft ³]	Allowable Bearing [psf]	Default
1 Default	Single	1e+5	1499.99999	Yes

Slab

Label	Thickness [in]	Material	Local Axis Angle [deg]	Analysis Offset [in]	Passive Pressure [psf]	Soil Overburden [psf]	Icr Factor
1 S1	32	Conc3000NW	0	0	0	0	0.25
2 S2	32	Conc3000NW	0	0	0	0	0.25
3 S3	32	Conc3000NW	0	0	0	0	0.25
4 S4	32	Conc3000NW	0	0	0	0	0.25
5 S5	32	Conc3000NW	0	0	0	0	0.25
6 S6	32	Conc3000NW	0	0	0	0	0.25
7 S7	32	Conc3000NW	0	0	0	0	0.25
8 S8	32	Conc3000NW	0	0	0	0	0.25
9 S9	32	Conc3000NW	0	0	0	0	0.25
10 S10	32	Conc3000NW	0	0	0	0	0.25
11 S11	32	Conc3000NW	0	0	0	0	0.25
12 S12	32	Conc3000NW	0	0	0	0	0.25
13 S13	32	Conc3000NW	0	0	0	0	0.25
14 S14	32	Conc3000NW	0	0	0	0	0.25

Load Category

Category	Node Loads
1 DL	32
2 RLL	59
3 WLZ	58
4 OL1	80
5 OL2	84
6 OL3	80
7 OL4	80

Load Combination

Label	Solve	Service	SF	Category	Factor	Category	Factor	Category	Factor
1 ASD Loads									
2 1.0 D	Yes	Yes	1.5	DL	1				
3 1.0 D + 1.0 S	Yes	Yes	1.5	DL	1	RLL	1		

Load Combination (Continued)

	Label	Solve	Service	SF	Category	Factor	Category	Factor	Category	Factor
4	1.0 D + 0.6 W1	Yes	Yes	1.5	DL	1	RLL		OL1	0.6
5	1.0 D + 0.6 W2	Yes	Yes	1.5	DL	1	RLL		OL2	0.6
6	1.0 D + 0.6 W3	Yes	Yes	1.5	DL	1	RLL		OL3	0.6
7	1.0 D + 0.6 W4	Yes	Yes	1.5	DL	1	RLL		OL4	0.6
8	1.0 D + 0.45 W1 + 0.75 S	Yes	Yes	1.5	DL	1	RLL	0.75	OL1	0.45
9	1.0 D + 0.45 W2 + 0.75 S	Yes	Yes	1.5	DL	1	RLL	0.75	OL2	0.45
10	1.0 D + 0.45 W3 + 0.75 S	Yes	Yes	1.5	DL	1	RLL	0.75	OL3	0.45
11	1.0 D + 0.45 W4 + 0.75 S	Yes	Yes	1.5	DL	1	RLL	0.75	OL4	0.45
12	0.6 D + 0.6 W1	Yes	Yes		DL	0.6	RLL		OL1	0.6
13	0.6 D + 0.6 W2	Yes	Yes		DL	0.6	RLL		OL2	0.6
14	0.6 D + 0.6 W3	Yes	Yes		DL	0.6	RLL		OL3	0.6
15	0.6 D + 0.6 W4	Yes	Yes		DL	0.6	RLL		OL4	0.6
16										
17	LRFD Loads									
18	1.4 D	Yes			DL	1.4	RLL			
19	1.2 D + 1.6 S + 0.5 W1	Yes			DL	1.2	RLL	1.6	OL1	0.5
20	1.2 D + 1.6 S + 0.5 W2	Yes			DL	1.2	RLL	1.6	OL2	0.5
21	1.2 D + 1.6 S + 0.5 W3	Yes			DL	1.2	RLL	1.6	OL3	0.5
22	1.2 D + 1.6 S + 0.5 W4	Yes			DL	1.2	RLL	1.6	OL4	0.5
23	1.2 D + 1.0 W1	Yes			DL	1.2	RLL		OL1	1
24	1.2 D + 1.0 W2	Yes			DL	1.2	RLL		OL2	1
25	1.2 D + 1.0 W3	Yes			DL	1.2	RLL		OL3	1
26	1.2 D + 1.0 W4	Yes			DL	1.2	RLL		OL4	1
27	0.9 D + 1.0 W1	Yes			DL	0.9	RLL		OL1	1
28	0.9 D + 1.0 W2	Yes			DL	0.9	RLL		OL2	1
29	0.9 D + 1.0 W3	Yes			DL	0.9	RLL		OL3	1
30	0.9 D + 1.0 W4	Yes			DL	0.9	RLL		OL4	1

Design Strips

	Label	Rebar Angle from Plan Horizontal (deg)	No. of Design Cuts	Design Rule
1	DS1	90	50	Typical
2	DS2	0	50	Typical

Strip Reinforcing

Label	UC Top	LC Top	Top Bars	Gov Design Cut	UC Top	UC Bot	LC Bot	Bot Bars	Mid Bars	Gov Design Cut	UC Bot	UC Shear	LC Gov Design Cut	UC Shear
1	DS1	0.001	27	#5@5in	DS1-X26	0.002	21	#5@5in	DS1-X25	0.009	21	DS1-X50		
2	DS2	0.01	21	#5@5in	DS2-X26	0.007	28	#5@5in	DS2-X26	0.055	21	DS2-X15		

Slab Soil Pressures

	LC	Label	UC	Soil Pressure[psf]	Allowable Bearing[psf]	Node
1	2	S1	0.27	405.157	1500	N25
2	2	S2	0.268	401.941	1500	N128
3	2	S3	0.269	403.085	1500	N129
4	2	S4	0.268	402.582	1500	N133
5	2	S5	0.268	402.634	1500	N137
6	2	S6	0.268	402.584	1500	N141
7	2	S7	0.268	402.662	1500	N145
8	2	S8	0.268	402.668	1500	N149
9	2	S9	0.268	402.584	1500	N153
10	2	S10	0.268	402.635	1500	N157
11	2	S11	0.268	402.581	1500	N161
12	2	S12	0.269	403.091	1500	N165

Slab Soil Pressures (Continued)

	LC	Label	UC	Soil Pressure[psf]	Allowable Bearing[psf]	Node
13	2	S13	0.268	401.983	1500	N172
14	2	S14	0.27	405.087	1500	N173
15	3	S1	0.369	552.878	1500	N25
16	3	S2	0.37	554.373	1500	N128
17	3	S3	0.364	546.275	1500	N129
18	3	S4	0.36	540.068	1500	N133
19	3	S5	0.36	540.661	1500	N137
20	3	S6	0.36	539.998	1500	N141
21	3	S7	0.361	541.078	1500	N145
22	3	S8	0.361	541.13	1500	N149
23	3	S9	0.36	540	1500	N153
24	3	S10	0.36	540.668	1500	N157
25	3	S11	0.36	540.053	1500	N161
26	3	S12	0.364	546.372	1500	N165
27	3	S13	0.37	555.027	1500	N172
28	3	S14	0.368	551.807	1500	N173
29	4	S1	0.337	504.98	1500	N28
30	4	S2	0.345	517.721	1500	N127
31	4	S3	0.351	527.219	1500	N131
32	4	S4	0.348	522.609	1500	N135
33	4	S5	0.35	525.308	1500	N139
34	4	S6	0.348	522.134	1500	N143
35	4	S7	0.35	524.459	1500	N147
36	4	S8	0.35	524.696	1500	N151
37	4	S9	0.348	522.138	1500	N155
38	4	S10	0.35	525.308	1500	N159
39	4	S11	0.348	522.61	1500	N163
40	4	S12	0.351	527.207	1500	N167
41	4	S13	0.345	517.756	1500	N171
42	4	S14	0.337	505.037	1500	N175
43	5	S1	0.371	556.831	1500	N28
44	5	S2	0.385	577.733	1500	N127
45	5	S3	0.392	587.933	1500	N131
46	5	S4	0.389	583.181	1500	N135
47	5	S5	0.391	585.943	1500	N139
48	5	S6	0.388	582.085	1500	N143
49	5	S7	0.39	585.319	1500	N147
50	5	S8	0.39	585.613	1500	N151
51	5	S9	0.388	582.089	1500	N155
52	5	S10	0.391	585.942	1500	N159
53	5	S11	0.389	583.183	1500	N163
54	5	S12	0.392	587.921	1500	N167
55	5	S13	0.385	577.767	1500	N171
56	5	S14	0.371	556.89	1500	N175
57	6	S1	0.462	692.762	1500	N25
58	6	S2	0.458	686.739	1500	N125
59	6	S3	0.484	725.979	1500	N129
60	6	S4	0.477	716.248	1500	N133
61	6	S5	0.48	719.962	1500	N137
62	6	S6	0.477	715.555	1500	N141
63	6	S7	0.479	719.249	1500	N145
64	6	S8	0.48	719.541	1500	N149
65	6	S9	0.477	715.561	1500	N153
66	6	S10	0.48	719.965	1500	N157
67	6	S11	0.477	716.248	1500	N161

Slab Soil Pressures (Continued)

	LC	Label	UC	Soil Pressure[psf]	Allowable Bearing[psf]	Node
68	6	S12	0.484	725.979	1500	N165
69	6	S13	0.458	686.694	1500	N169
70	6	S14	0.462	692.686	1500	N173
71	7	S1	0.397	595.046	1500	N25
72	7	S2	0.398	596.671	1500	N125
73	7	S3	0.413	620.217	1500	N129
74	7	S4	0.409	613.931	1500	N133
75	7	S5	0.411	616.364	1500	N137
76	7	S6	0.409	613.553	1500	N141
77	7	S7	0.411	615.859	1500	N145
78	7	S8	0.411	616.038	1500	N149
79	7	S9	0.409	613.558	1500	N153
80	7	S10	0.411	616.365	1500	N157
81	7	S11	0.409	613.931	1500	N161
82	7	S12	0.413	620.218	1500	N165
83	7	S13	0.398	596.628	1500	N169
84	7	S14	0.397	594.971	1500	N173
85	8	S1	0.358	536.799	1500	N27
86	8	S2	0.39	585.699	1500	N128
87	8	S3	0.385	578.035	1500	N132
88	8	S4	0.384	576.376	1500	N136
89	8	S5	0.385	577.898	1500	N140
90	8	S6	0.384	575.42	1500	N144
91	8	S7	0.385	577.945	1500	N148
92	8	S8	0.385	577.768	1500	N152
93	8	S9	0.384	575.422	1500	N156
94	8	S10	0.385	577.894	1500	N160
95	8	S11	0.384	576.389	1500	N164
96	8	S12	0.385	577.953	1500	N168
97	8	S13	0.391	586.195	1500	N172
98	8	S14	0.358	537.568	1500	N176
99	9	S1	0.385	578.062	1500	N27
100	9	S2	0.424	635.943	1500	N128
101	9	S3	0.418	627.427	1500	N132
102	9	S4	0.417	625.907	1500	N136
103	9	S5	0.418	627.396	1500	N140
104	9	S6	0.416	624.409	1500	N144
105	9	S7	0.418	627.705	1500	N148
106	9	S8	0.418	627.479	1500	N152
107	9	S9	0.416	624.411	1500	N156
108	9	S10	0.418	627.392	1500	N160
109	9	S11	0.417	625.919	1500	N164
110	9	S12	0.418	627.345	1500	N168
111	9	S13	0.424	636.439	1500	N172
112	9	S14	0.386	578.832	1500	N176
113	10	S1	0.488	731.652	1500	N25
114	10	S2	0.461	691.812	1500	N125
115	10	S3	0.502	752.647	1500	N129
116	10	S4	0.494	740.946	1500	N133
117	10	S5	0.496	744.15	1500	N137
118	10	S6	0.494	740.373	1500	N141
119	10	S7	0.496	743.914	1500	N145
120	10	S8	0.496	744.169	1500	N149
121	10	S9	0.494	740.378	1500	N153
122	10	S10	0.496	744.157	1500	N157

Slab Soil Pressures (Continued)

	LC	Label	UC	Soil Pressure[psf]	Allowable Bearing[psf]	Node
123	10	S11	0.494	740.935	1500	N161
124	10	S12	0.502	752.718	1500	N165
125	10	S13	0.461	691.362	1500	N169
126	10	S14	0.487	730.826	1500	N173
127	11	S1	0.439	658.364	1500	N25
128	11	S2	0.416	624.26	1500	N125
129	11	S3	0.449	673.326	1500	N129
130	11	S4	0.443	664.208	1500	N133
131	11	S5	0.444	666.451	1500	N137
132	11	S6	0.443	663.872	1500	N141
133	11	S7	0.444	666.371	1500	N145
134	11	S8	0.444	666.542	1500	N149
135	11	S9	0.443	663.876	1500	N153
136	11	S10	0.444	666.457	1500	N157
137	11	S11	0.443	664.198	1500	N161
138	11	S12	0.449	673.397	1500	N165
139	11	S13	0.416	623.813	1500	N169
140	11	S14	0.438	657.539	1500	N173
141	12	S1	0.232	348.411	1500	N28
142	12	S2	0.24	359.372	1500	N127
143	12	S3	0.248	372.643	1500	N131
144	12	S4	0.245	366.806	1500	N135
145	12	S5	0.247	369.897	1500	N139
146	12	S6	0.244	366.286	1500	N143
147	12	S7	0.246	368.973	1500	N147
148	12	S8	0.246	369.266	1500	N151
149	12	S9	0.244	366.291	1500	N155
150	12	S10	0.247	369.897	1500	N159
151	12	S11	0.245	366.808	1500	N163
152	12	S12	0.248	372.631	1500	N167
153	12	S13	0.24	359.391	1500	N171
154	12	S14	0.232	348.448	1500	N175
155	13	S1	0.27	404.973	1500	N28
156	13	S2	0.282	422.739	1500	N127
157	13	S3	0.298	446.702	1500	N131
158	13	S4	0.292	437.96	1500	N135
159	13	S5	0.295	442.183	1500	N139
160	13	S6	0.291	436.582	1500	N143
161	13	S7	0.294	441.344	1500	N147
162	13	S8	0.295	441.776	1500	N151
163	13	S9	0.291	436.587	1500	N155
164	13	S10	0.295	442.184	1500	N159
165	13	S11	0.292	437.962	1500	N163
166	13	S12	0.298	446.688	1500	N167
167	13	S13	0.282	422.759	1500	N171
168	13	S14	0.27	405.054	1500	N175
169	14	S1	0.354	530.7	1500	N25
170	14	S2	0.351	526.929	1500	N125
171	14	S3	0.376	564.745	1500	N129
172	14	S4	0.37	555.215	1500	N133
173	14	S5	0.373	558.909	1500	N137
174	14	S6	0.37	554.521	1500	N141
175	14	S7	0.372	558.184	1500	N145
176	14	S8	0.372	558.474	1500	N149
177	14	S9	0.37	554.527	1500	N153

Slab Soil Pressures (Continued)

	LC	Label	UC	Soil Pressure[psf]	Allowable Bearing[psf]	Node
178	14	S10	0.373	558.911	1500	N157
179	14	S11	0.37	555.216	1500	N161
180	14	S12	0.376	564.742	1500	N165
181	14	S13	0.351	526.898	1500	N169
182	14	S14	0.354	530.651	1500	N173
183	15	S1	0.289	432.983	1500	N25
184	15	S2	0.291	436.86	1500	N125
185	15	S3	0.306	458.983	1500	N129
186	15	S4	0.302	452.899	1500	N133
187	15	S5	0.304	455.31	1500	N137
188	15	S6	0.302	452.52	1500	N141
189	15	S7	0.303	454.794	1500	N145
190	15	S8	0.303	454.971	1500	N149
191	15	S9	0.302	452.524	1500	N153
192	15	S10	0.304	455.311	1500	N157
193	15	S11	0.302	452.899	1500	N161
194	15	S12	0.306	458.981	1500	N165
195	15	S13	0.291	436.832	1500	N169
196	15	S14	0.289	432.936	1500	N173

Slab Stability - Overturning

	LC	Slab	Angle[deg]	Mo-xx[lb-ft]	Ms-xx[lb-ft]	Mo-zz[lb-ft]	Ms-zz[lb-ft]	Ms-xx/Mo-xx	Ms-zz/Mo-zz
1	2	S1	0	0	58258.821	0	13583.178	9.99+	9.99+
2	2	S2	0	0	58459.415	0	13521.046	9.99+	9.99+
3	2	S3	0	0	58471.028	0	13555.336	9.99+	9.99+
4	2	S4	0	0	58466.794	0	13550.019	9.99+	9.99+
5	2	S5	0	0	58463.989	0	13549.984	9.99+	9.99+
6	2	S6	0	0	58460.638	0	13548.919	9.99+	9.99+
7	2	S7	0	0	58470.236	0	13551.396	9.99+	9.99+
8	2	S8	0	0	58470.236	0	13551.397	9.99+	9.99+
9	2	S9	0	0	58460.635	0	13548.92	9.99+	9.99+
10	2	S10	0	0	58463.982	0	13549.987	9.99+	9.99+
11	2	S11	0	0	58466.848	0	13550.02	9.99+	9.99+
12	2	S12	0	0	58470.699	0	13555.334	9.99+	9.99+
13	2	S13	0	0	58461.692	0	13521.121	9.99+	9.99+
14	2	S14	0	0	58261.957	0	13487.968	9.99+	9.99+
15	3	S1	0	0	72093.564	0	17909.929	9.99+	9.99+
16	3	S2	0	0	74862.85	0	17423.401	9.99+	9.99+
17	3	S3	0	0	75025.074	0	17844.192	9.99+	9.99+
18	3	S4	0	0	74940.03	0	17787.125	9.99+	9.99+
19	3	S5	0	0	74920.925	0	17789.253	9.99+	9.99+
20	3	S6	0	0	74873.603	0	17753.477	9.99+	9.99+
21	3	S7	0	0	74997.6	0	17793.723	9.99+	9.99+
22	3	S8	0	0	74997.587	0	17804.807	9.99+	9.99+
23	3	S9	0	0	74873.573	0	17779.923	9.99+	9.99+
24	3	S10	0	0	74920.837	0	17769.731	9.99+	9.99+
25	3	S11	0	0	74940.655	0	17775.49	9.99+	9.99+
26	3	S12	0	0	75020.488	0	17850.868	9.99+	9.99+
27	3	S13	0	0	74897.552	0	17427.089	9.99+	9.99+
28	3	S14	0	0	72142.269	0	16845.636	9.99+	9.99+
29	4	S1	0	20755.794	58652.705	2899.8	13583.178	2.826	4.684
30	4	S2	0	21328.718	58338.937	2354.28	13521.046	2.735	5.743
31	4	S3	0	23485.696	58593.934	2706.075	13555.336	2.495	5.009
32	4	S4	0	22958.175	58556.825	2654.953	13550.019	2.551	5.104
33	4	S5	0	23156.419	58559.355	2665.963	13549.984	2.529	5.083

Slab Stability - Overturning (Continued)

	LC	Slab	Angle[deg]	Mo-xx[lb-ft]	Ms-xx[lb-ft]	Mo-zz[lb-ft]	Ms-zz[lb-ft]	Ms-xx/Mo-xx	Ms-zz/Mo-zz
34	4	S6	0	22900.467	58554.427	2648.167	13548.919	2.557	5.116
35	4	S7	0	23130.54	58564.085	2664.962	13551.396	2.532	5.085
36	4	S8	0	23130.63	58564.094	2668.448	13551.397	2.532	5.078
37	4	S9	0	22900.757	58554.435	2654.289	13548.92	2.557	5.105
38	4	S10	0	23156.533	58559.389	2657.628	13549.987	2.529	5.099
39	4	S11	0	22958.257	58556.781	2654.282	13550.02	2.551	5.105
40	4	S12	0	23485.433	58594.244	2718.624	13555.334	2.495	4.986
41	4	S13	0	21328.321	58337.238	2343.697	13521.121	2.735	5.769
42	4	S14	0	20755.403	58649.114	2384.678	13491.51	2.826	5.658
43	5	S1	0	21617.047	58652.705	2696.701	13583.178	2.713	5.037
44	5	S2	0	20884.792	58338.937	1795.397	13521.046	2.793	7.531
45	5	S3	0	23869.581	58593.934	2283.921	13555.336	2.455	5.935
46	5	S4	0	23193.244	58556.825	2205.401	13550.019	2.525	6.144
47	5	S5	0	23444.571	58559.355	2224.23	13549.984	2.498	6.092
48	5	S6	0	23145.235	58554.427	2215.076	13548.919	2.53	6.117
49	5	S7	0	23401.847	58564.085	2223.902	13551.396	2.503	6.094
50	5	S8	0	23401.954	58564.094	2222.66	13551.397	2.503	6.097
51	5	S9	0	23145.553	58554.435	2209.973	13548.92	2.53	6.131
52	5	S10	0	23444.746	58559.389	2222.908	13549.987	2.498	6.096
53	5	S11	0	23193.325	58556.781	2209.832	13550.02	2.525	6.132
54	5	S12	0	23869.364	58594.244	2300.679	13555.334	2.455	5.892
55	5	S13	0	20884.34	58337.238	1759.562	13521.121	2.793	7.684
56	5	S14	0	21616.696	58649.114	2234.632	13491.51	2.713	6.037
57	6	S1	0	1504.642	58258.821	0	16968.891	9.99+	9.99+
58	6	S2	0	3578.629	58459.415	0	16269.828	9.99+	9.99+
59	6	S3	0	2798.6	58471.028	0	16714.861	9.99+	9.99+
60	6	S4	0	2706.687	58466.794	0	16649.857	9.99+	9.99+
61	6	S5	0	2873.104	58463.989	0	16662.676	9.99+	9.99+
62	6	S6	0	2670.112	58460.638	0	16640.833	9.99+	9.99+
63	6	S7	0	2798.233	58470.236	0	16662.919	9.99+	9.99+
64	6	S8	0	2798.234	58470.236	0	16666.99	9.99+	9.99+
65	6	S9	0	2670.341	58460.635	0	16647.982	9.99+	9.99+
66	6	S10	0	2872.959	58463.982	0	16652.948	9.99+	9.99+
67	6	S11	0	2706.717	58466.848	0	16649.074	9.99+	9.99+
68	6	S12	0	2798.082	58470.699	0	16729.512	9.99+	9.99+
69	6	S13	0	3578.203	58461.692	0	16257.546	9.99+	9.99+
70	6	S14	0	1504.085	58261.957	0	15948.907	9.99+	9.99+
71	7	S1	0	0	59634.59	0	16398.314	9.99+	9.99+
72	7	S2	0	0	59228.223	0	16156.648	9.99+	9.99+
73	7	S3	0	0	59536.052	0	16389.086	9.99+	9.99+
74	7	S4	0	0	59657.296	0	16360.85	9.99+	9.99+
75	7	S5	0	0	59511.566	0	16364.686	9.99+	9.99+
76	7	S6	0	0	59630.932	0	16341.512	9.99+	9.99+
77	7	S7	0	0	59596.998	0	16365.638	9.99+	9.99+
78	7	S8	0	0	59596.993	0	16370.911	9.99+	9.99+
79	7	S9	0	0	59630.711	0	16353.57	9.99+	9.99+
80	7	S10	0	0	59511.672	0	16350.886	9.99+	9.99+
81	7	S11	0	0	59657.337	0	16357.34	9.99+	9.99+
82	7	S12	0	0	59536.15	0	16396.747	9.99+	9.99+
83	7	S13	0	0	59230.798	0	16169.543	9.99+	9.99+
84	7	S14	0	0	59638.214	0	15680.805	9.99+	9.99+
85	8	S1	0	15566.845	70684.32	2174.85	16828.242	4.541	7.738
86	8	S2	0	15996.538	68798.341	1765.71	16447.813	4.301	9.315
87	8	S3	0	17614.272	71208.306	2029.556	16771.978	4.043	8.264
88	8	S4	0	17218.631	70875.471	1991.215	16727.849	4.116	8.401

Slab Stability - Overturning (Continued)

	LC	Slab	Angle[deg]	Mo-xx[lb-ft]	Ms-xx[lb-ft]	Mo-zz[lb-ft]	Ms-zz[lb-ft]	Ms-xx/Mo-xx	Ms-zz/Mo-zz
89	8	S5	0	17367.314	70887.957	1999.473	16729.436	4.082	8.367
90	8	S6	0	17175.351	70840.23	1986.125	16702.337	4.125	8.41
91	8	S7	0	17347.905	70938.908	1998.721	16733.142	4.089	8.372
92	8	S8	0	17347.972	70938.996	2001.336	16741.454	4.089	8.365
93	8	S9	0	17175.568	70840.297	1990.717	16722.172	4.124	8.4
94	8	S10	0	17367.4	70888.277	1993.221	16714.795	4.082	8.386
95	8	S11	0	17218.693	70875.093	1990.711	16719.123	4.116	8.399
96	8	S12	0	17614.075	71211.548	2038.968	16776.985	4.043	8.228
97	8	S13	0	15996.241	68778.619	1757.773	16450.597	4.3	9.359
98	8	S14	0	15566.553	70641.589	1788.509	16143.115	4.538	9.026
99	9	S1	0	16212.785	70684.32	2022.526	16828.242	4.36	8.32
100	9	S2	0	15663.594	68798.341	1346.548	16447.813	4.392	9.99+
101	9	S3	0	17902.185	71208.306	1712.941	16771.978	3.978	9.791
102	9	S4	0	17394.933	70875.471	1654.051	16727.849	4.074	9.99+
103	9	S5	0	17583.428	70887.957	1668.173	16729.436	4.032	9.99+
104	9	S6	0	17358.926	70840.23	1661.307	16702.337	4.081	9.99+
105	9	S7	0	17551.386	70938.908	1667.926	16733.142	4.042	9.99+
106	9	S8	0	17551.465	70938.996	1666.995	16741.454	4.042	9.99+
107	9	S9	0	17359.165	70840.297	1657.48	16722.172	4.081	9.99+
108	9	S10	0	17583.559	70888.277	1667.181	16714.795	4.032	9.99+
109	9	S11	0	17394.993	70875.093	1657.374	16719.123	4.074	9.99+
110	9	S12	0	17902.023	71211.548	1725.509	16776.985	3.978	9.723
111	9	S13	0	15663.255	68778.619	1319.672	16450.597	4.391	9.99+
112	9	S14	0	16212.522	70641.589	1675.974	16143.115	4.357	9.632
113	10	S1	0	1128.482	68634.878	0	19367.526	9.99+	9.99+
114	10	S2	0	2683.972	70761.992	0	18509.399	9.99+	9.99+
115	10	S3	0	2098.95	70886.562	0	19141.622	9.99+	9.99+
116	10	S4	0	2030.015	70821.721	0	19052.727	9.99+	9.99+
117	10	S5	0	2154.828	70806.691	0	19063.955	9.99+	9.99+
118	10	S6	0	2002.584	70770.362	0	19021.273	9.99+	9.99+
119	10	S7	0	2098.675	70865.759	0	19066.784	9.99+	9.99+
120	10	S8	0	2098.675	70865.749	0	19078.149	9.99+	9.99+
121	10	S9	0	2002.756	70770.338	0	19046.469	9.99+	9.99+
122	10	S10	0	2154.719	70806.623	0	19042.016	9.99+	9.99+
123	10	S11	0	2030.038	70822.203	0	19043.413	9.99+	9.99+
124	10	S12	0	2098.561	70883.041	0	19157.618	9.99+	9.99+
125	10	S13	0	2683.652	70788.587	0	18502.916	9.99+	9.99+
126	10	S14	0	1128.063	68672.191	0	17851.923	9.99+	9.99+
127	11	S1	0	0	69666.706	0	18939.594	9.99+	9.99+
128	11	S2	0	0	71338.598	0	18424.514	9.99+	9.99+
129	11	S3	0	0	71685.331	0	18897.29	9.99+	9.99+
130	11	S4	0	0	71714.598	0	18835.971	9.99+	9.99+
131	11	S5	0	0	71592.373	0	18840.463	9.99+	9.99+
132	11	S6	0	0	71648.082	0	18796.782	9.99+	9.99+
133	11	S7	0	0	71710.83	0	18843.823	9.99+	9.99+
134	11	S8	0	0	71710.817	0	18856.09	9.99+	9.99+
135	11	S9	0	0	71647.895	0	18825.66	9.99+	9.99+
136	11	S10	0	0	71592.391	0	18815.469	9.99+	9.99+
137	11	S11	0	0	71715.07	0	18824.613	9.99+	9.99+
138	11	S12	0	0	71682.129	0	18908.045	9.99+	9.99+
139	11	S13	0	0	71365.416	0	18436.914	9.99+	9.99+
140	11	S14	0	0	69704.384	0	17650.847	9.99+	9.99+
141	12	S1	0	20755.794	35191.623	2899.8	8149.907	1.696	2.811
142	12	S2	0	21328.718	35003.362	2354.28	8112.628	1.641	3.446
143	12	S3	0	23485.696	35156.36	2706.075	8133.202	1.497	3.006

Slab Stability - Overturning (Continued)

	LC	Slab	Angle[deg]	Mo-xx[lb-ft]	Ms-xx[lb-ft]	Mo-zz[lb-ft]	Ms-zz[lb-ft]	Ms-xx/Mo-xx	Ms-zz/Mo-zz
144	12	S4	0	22958.175	35134.095	2654.953	8130.011	1.53	3.062
145	12	S5	0	23156.419	35135.613	2665.963	8129.99	1.517	3.05
146	12	S6	0	22900.467	35132.656	2648.167	8129.351	1.534	3.07
147	12	S7	0	23130.54	35138.451	2664.962	8130.837	1.519	3.051
148	12	S8	0	23130.63	35138.457	2668.448	8130.838	1.519	3.047
149	12	S9	0	22900.757	35132.661	2654.289	8129.352	1.534	3.063
150	12	S10	0	23156.533	35135.633	2657.628	8129.992	1.517	3.059
151	12	S11	0	22958.257	35134.068	2654.282	8130.012	1.53	3.063
152	12	S12	0	23485.433	35156.546	2718.624	8133.2	1.497	2.992
153	12	S13	0	21328.321	35002.343	2343.697	8112.672	1.641	3.461
154	12	S14	0	20755.403	35189.469	2384.678	8094.906	1.695	3.395
155	13	S1	0	21617.047	35191.623	2696.701	8149.907	1.628	3.022
156	13	S2	0	20884.792	35003.362	1795.397	8112.628	1.676	4.519
157	13	S3	0	23869.581	35156.36	2283.921	8133.202	1.473	3.561
158	13	S4	0	23193.244	35134.095	2205.401	8130.011	1.515	3.686
159	13	S5	0	23444.571	35135.613	2224.23	8129.99	1.499	3.655
160	13	S6	0	23145.235	35132.656	2215.076	8129.351	1.518	3.67
161	13	S7	0	23401.847	35138.451	2223.902	8130.837	1.502	3.656
162	13	S8	0	23401.954	35138.457	2222.66	8130.838	1.502	3.658
163	13	S9	0	23145.553	35132.661	2209.973	8129.352	1.518	3.678
164	13	S10	0	23444.746	35135.633	2222.908	8129.992	1.499	3.657
165	13	S11	0	23193.325	35134.068	2209.832	8130.012	1.515	3.679
166	13	S12	0	23869.364	35156.546	2300.679	8133.2	1.473	3.535
167	13	S13	0	20884.34	35002.343	1759.562	8112.672	1.676	4.611
168	13	S14	0	21616.696	35189.469	2234.632	8094.906	1.628	3.622
169	14	S1	0	1504.642	34955.293	0	11535.62	9.99+	9.99+
170	14	S2	0	3578.629	35075.649	0	10861.409	9.801	9.99+
171	14	S3	0	2798.6	35082.617	0	11292.727	9.99+	9.99+
172	14	S4	0	2706.687	35080.076	0	11229.849	9.99+	9.99+
173	14	S5	0	2873.104	35078.393	0	11242.683	9.99+	9.99+
174	14	S6	0	2670.112	35076.383	0	11221.265	9.99+	9.99+
175	14	S7	0	2798.233	35082.142	0	11242.361	9.99+	9.99+
176	14	S8	0	2798.234	35082.142	0	11246.431	9.99+	9.99+
177	14	S9	0	2670.341	35076.381	0	11228.414	9.99+	9.99+
178	14	S10	0	2872.959	35078.389	0	11232.953	9.99+	9.99+
179	14	S11	0	2706.717	35080.109	0	11229.066	9.99+	9.99+
180	14	S12	0	2798.082	35082.419	0	11307.378	9.99+	9.99+
181	14	S13	0	3578.203	35077.015	0	10849.097	9.803	9.99+
182	14	S14	0	1504.085	34957.174	0	10553.72	9.99+	9.99+
183	15	S1	0	0	36331.062	0	10965.043	9.99+	9.99+
184	15	S2	0	0	35844.457	0	10748.23	9.99+	9.99+
185	15	S3	0	0	36147.641	0	10966.952	9.99+	9.99+
186	15	S4	0	0	36270.578	0	10940.842	9.99+	9.99+
187	15	S5	0	0	36125.97	0	10944.692	9.99+	9.99+
188	15	S6	0	0	36246.677	0	10921.944	9.99+	9.99+
189	15	S7	0	0	36208.904	0	10945.08	9.99+	9.99+
190	15	S8	0	0	36208.898	0	10950.352	9.99+	9.99+
191	15	S9	0	0	36246.457	0	10934.002	9.99+	9.99+
192	15	S10	0	0	36126.079	0	10930.891	9.99+	9.99+
193	15	S11	0	0	36270.598	0	10937.332	9.99+	9.99+
194	15	S12	0	0	36147.87	0	10974.614	9.99+	9.99+
195	15	S13	0	0	35846.121	0	10761.094	9.99+	9.99+
196	15	S14	0	0	36333.431	0	10285.618	9.99+	9.99+

Slab Stability - Sliding

	LC	Slab	Angle[deg]	Va-xx[lb]	Vr-xx[lb]	Va-zz[lb]	Vr-zz[lb]	SR-xx	SR-zz
1	2	S1	0	17.841	3237.55	0	3237.55	9.99+	9.99+
2	2	S2	0	0	3234.416	0	3234.416	9.99+	9.99+
3	2	S3	0	0	3241.799	0	3241.799	9.99+	9.99+
4	2	S4	0	0	3240.654	0	3240.654	9.99+	9.99+
5	2	S5	0	0	3240.646	0	3240.646	9.99+	9.99+
6	2	S6	0	0	3240.417	0	3240.417	9.99+	9.99+
7	2	S7	0	0	3240.95	0	3240.95	9.99+	9.99+
8	2	S8	0	0	3240.951	0	3240.951	9.99+	9.99+
9	2	S9	0	0	3240.417	0	3240.417	9.99+	9.99+
10	2	S10	0	0	3240.647	0	3240.647	9.99+	9.99+
11	2	S11	0	0	3240.654	0	3240.654	9.99+	9.99+
12	2	S12	0	0	3241.798	0	3241.798	9.99+	9.99+
13	2	S13	0	0	3234.432	0	3234.432	9.99+	9.99+
14	2	S14	0	17.841	3237.537	0	3237.537	9.99+	9.99+
15	3	S1	0	199.387	4064.91	2.148	4064.91	9.99+	9.99+
16	3	S2	0	0.387	4074.858	6.261	4074.858	9.99+	9.99+
17	3	S3	0	1.295	4165.98	6.838	4165.98	9.99+	9.99+
18	3	S4	0	2.214	4151.678	3.761	4151.678	9.99+	9.99+
19	3	S5	0	3.171	4151.587	1.051	4151.587	9.99+	9.99+
20	3	S6	0	4.972	4148.56	0	4148.56	9.99+	9.99+
21	3	S7	0	2.051	4155.548	0	4155.548	9.99+	9.99+
22	3	S8	0	2.101	4155.551	0	4155.551	9.99+	9.99+
23	3	S9	0	4.942	4148.561	0	4148.561	9.99+	9.99+
24	3	S10	0	4.165	4151.596	1.066	4151.596	9.99+	9.99+
25	3	S11	0	2.155	4151.682	3.839	4151.682	9.99+	9.99+
26	3	S12	0	1.227	4165.97	7.038	4165.97	9.99+	9.99+
27	3	S13	0	0.563	4075.107	6.463	4075.107	9.99+	9.99+
28	3	S14	0	199.382	4064.714	2.227	4064.714	9.99+	9.99+
29	4	S1	0	130.671	2698.461	1054.626	2698.461	9.99+	2.559
30	4	S2	0	1.983	2728.652	1406.843	2728.652	9.99+	1.94
31	4	S3	0	2.349	2657.803	1336.28	2657.803	9.99+	1.989
32	4	S4	0	0.127	2669.086	1335.201	2669.086	9.99+	1.999
33	4	S5	0	1.569	2667.536	1344.794	2667.536	9.99+	1.984
34	4	S6	0	1.146	2669.58	1327.563	2669.58	9.99+	2.011
35	4	S7	0	0.651	2666.781	1340.528	2666.781	9.99+	1.989
36	4	S8	0	0.652	2666.779	1340.529	2666.779	9.99+	1.989
37	4	S9	0	1.146	2669.578	1327.575	2669.578	9.99+	2.011
38	4	S10	0	1.568	2667.53	1344.784	2667.53	9.99+	1.984
39	4	S11	0	0.128	2669.085	1335.206	2669.085	9.99+	1.999
40	4	S12	0	2.349	2657.797	1336.258	2657.797	9.99+	1.989
41	4	S13	0	1.984	2728.669	1406.825	2728.669	9.99+	1.94
42	4	S14	0	130.671	2698.446	1054.598	2698.446	9.99+	2.559
43	5	S1	0	151.212	2753.985	881.803	2753.985	9.99+	3.123
44	5	S2	0	6.718	2851.704	1169.399	2851.704	9.99+	2.439
45	5	S3	0	3.137	2748.244	1117.203	2748.244	9.99+	2.46
46	5	S4	0	0.83	2765.33	1112.592	2765.33	9.99+	2.485
47	5	S5	0	0.255	2761.892	1124.778	2761.892	9.99+	2.456
48	5	S6	0	0.961	2764.039	1104.951	2764.039	9.99+	2.502
49	5	S7	0	0.235	2762.255	1118.997	2762.255	9.99+	2.469
50	5	S8	0	0.236	2762.252	1118.998	2762.252	9.99+	2.469
51	5	S9	0	0.961	2764.034	1104.963	2764.034	9.99+	2.501
52	5	S10	0	0.255	2761.884	1124.769	2761.884	9.99+	2.456
53	5	S11	0	0.83	2765.33	1112.597	2765.33	9.99+	2.485
54	5	S12	0	3.137	2748.238	1117.181	2748.238	9.99+	2.46
55	5	S13	0	6.718	2851.722	1169.376	2851.722	9.99+	2.439

Slab Stability - Sliding (Continued)

	LC	Slab	Angle[deg]	Va-xx[lb]	Vr-xx[lb]	Va-zz[lb]	Vr-zz[lb]	SR-xx	SR-zz
56	5	S14	0	151.212	2753.97	881.776	2753.97	9.99+	3.123
57	6	S1	0	191.239	3866.973	1231.347	3866.973	9.99+	3.14
58	6	S2	0	2.316	3824.929	1642.584	3824.929	9.99+	2.329
59	6	S3	0	2.742	3923.654	1560.197	3923.654	9.99+	2.515
60	6	S4	0	0.148	3907.998	1558.937	3907.998	9.99+	2.507
61	6	S5	0	1.832	3909.792	1570.138	3909.792	9.99+	2.49
62	6	S6	0	1.338	3906.908	1550.02	3906.908	9.99+	2.521
63	6	S7	0	0.761	3911.332	1565.158	3911.332	9.99+	2.499
64	6	S8	0	0.761	3911.335	1565.158	3911.335	9.99+	2.499
65	6	S9	0	1.338	3906.911	1550.033	3906.911	9.99+	2.521
66	6	S10	0	1.831	3909.8	1570.126	3909.8	9.99+	2.49
67	6	S11	0	0.149	3908	1558.944	3908	9.99+	2.507
68	6	S12	0	2.743	3923.659	1560.171	3923.659	9.99+	2.515
69	6	S13	0	2.316	3824.944	1642.563	3824.944	9.99+	2.329
70	6	S14	0	191.238	3866.963	1231.315	3866.963	9.99+	3.141
71	7	S1	0	134.524	3776.684	1111.758	3776.684	9.99+	3.397
72	7	S2	0	2.404	3803.27	1489.188	3803.27	9.99+	2.554
73	7	S3	0	1.433	3852.759	1408.757	3852.759	9.99+	2.735
74	7	S4	0	0.66	3845.478	1410.915	3845.478	9.99+	2.726
75	7	S5	0	2.592	3845.194	1417.328	3845.194	9.99+	2.713
76	7	S6	0	2.26	3842.991	1403.979	3842.991	9.99+	2.737
77	7	S7	0	0.987	3847.454	1414.798	3847.454	9.99+	2.719
78	7	S8	0	0.987	3847.456	1414.799	3847.456	9.99+	2.719
79	7	S9	0	2.26	3842.992	1403.989	3842.992	9.99+	2.737
80	7	S10	0	2.592	3845.2	1417.317	3845.2	9.99+	2.713
81	7	S11	0	0.66	3845.48	1410.921	3845.48	9.99+	2.726
82	7	S12	0	1.434	3852.763	1408.737	3852.763	9.99+	2.735
83	7	S13	0	2.404	3803.286	1489.176	3803.286	9.99+	2.554
84	7	S14	0	134.524	3776.675	1111.732	3776.675	9.99+	3.397
85	8	S1	0	42.616	3453.754	792.58	3453.754	9.99+	4.358
86	8	S2	0	1.778	3485.425	1050.437	3485.425	9.99+	3.318
87	8	S3	0	0.79	3496.938	1007.338	3496.938	9.99+	3.471
88	8	S4	0	1.565	3495.246	998.58	3495.246	9.99+	3.5
89	8	S5	0	1.202	3494.019	1009.384	3494.019	9.99+	3.462
90	8	S6	0	2.87	3493.396	995.672	3493.396	9.99+	3.509
91	8	S7	0	1.05	3496.271	1005.396	3496.271	9.99+	3.478
92	8	S8	0	1.087	3496.272	1005.397	3496.272	9.99+	3.478
93	8	S9	0	2.847	3493.395	995.681	3493.395	9.99+	3.509
94	8	S10	0	1.948	3494.021	1009.387	3494.021	9.99+	3.462
95	8	S11	0	1.521	3495.248	998.525	3495.248	9.99+	3.5
96	8	S12	0	0.842	3496.926	1007.471	3496.926	9.99+	3.471
97	8	S13	0	1.91	3485.616	1050.271	3485.616	9.99+	3.319
98	8	S14	0	42.613	3453.602	792.619	3453.602	9.99+	4.357
99	9	S1	0	27.21	3495.396	662.963	3495.396	9.99+	5.272
100	9	S2	0	5.329	3577.714	872.354	3577.714	9.99+	4.101
101	9	S3	0	1.382	3564.769	843.031	3564.769	9.99+	4.229
102	9	S4	0	2.283	3567.429	831.623	3567.429	9.99+	4.29
103	9	S5	0	2.187	3564.786	844.372	3564.786	9.99+	4.222
104	9	S6	0	4.45	3564.24	828.713	3564.24	9.99+	4.301
105	9	S7	0	1.715	3567.877	839.248	3567.877	9.99+	4.251
106	9	S8	0	1.752	3567.877	839.249	3567.877	9.99+	4.251
107	9	S9	0	4.427	3564.238	828.722	3564.238	9.99+	4.301
108	9	S10	0	2.932	3564.786	844.376	3564.786	9.99+	4.222
109	9	S11	0	2.239	3567.431	831.568	3567.431	9.99+	4.29
110	9	S12	0	1.433	3564.757	843.164	3564.757	9.99+	4.228

Slab Stability - Sliding (Continued)

	LC	Slab	Angle[deg]	Va-xx[lb]	Vr-xx[lb]	Va-zz[lb]	Vr-zz[lb]	SR-xx	SR-zz
111	9	S13	0	5.461	3577.905	872.185	3577.905	9.99+	4.102
112	9	S14	0	27.207	3495.245	663.002	3495.245	9.99+	5.272
113	10	S1	0	284.049	4330.137	921.899	4330.137	9.99+	4.697
114	10	S2	0	1.446	4307.633	1236.633	4307.633	9.99+	3.483
115	10	S3	0	3.028	4446.326	1165.02	4446.326	9.99+	3.817
116	10	S4	0	1.772	4424.43	1172.024	4424.43	9.99+	3.775
117	10	S5	0	3.752	4425.711	1176.815	4425.711	9.99+	3.761
118	10	S6	0	4.732	4421.392	1162.515	4421.392	9.99+	3.803
119	10	S7	0	2.109	4429.685	1173.868	4429.685	9.99+	3.774
120	10	S8	0	2.146	4429.689	1173.869	4429.689	9.99+	3.774
121	10	S9	0	4.71	4421.396	1162.525	4421.396	9.99+	3.803
122	10	S10	0	4.497	4425.723	1176.795	4425.723	9.99+	3.761
123	10	S11	0	1.728	4424.434	1172.087	4424.434	9.99+	3.775
124	10	S12	0	2.977	4446.323	1164.85	4446.323	9.99+	3.817
125	10	S13	0	1.315	4307.822	1236.769	4307.822	9.99+	3.483
126	10	S14	0	284.045	4329.989	921.816	4329.989	9.99+	4.697
127	11	S1	0	241.513	4262.421	832.207	4262.421	9.99+	5.122
128	11	S2	0	2.094	4291.388	1121.586	4291.388	9.99+	3.826
129	11	S3	0	2.046	4393.155	1051.44	4393.155	9.99+	4.178
130	11	S4	0	2.155	4377.54	1061.008	4377.54	9.99+	4.126
131	11	S5	0	4.323	4377.263	1062.208	4377.263	9.99+	4.121
132	11	S6	0	5.425	4373.454	1052.984	4373.454	9.99+	4.153
133	11	S7	0	2.278	4381.776	1061.099	4381.776	9.99+	4.129
134	11	S8	0	2.316	4381.78	1061.099	4381.78	9.99+	4.129
135	11	S9	0	5.402	4373.456	1052.992	4373.456	9.99+	4.153
136	11	S10	0	5.068	4377.273	1062.189	4377.273	9.99+	4.121
137	11	S11	0	2.111	4377.544	1061.07	4377.544	9.99+	4.126
138	11	S12	0	1.995	4393.15	1051.275	4393.15	9.99+	4.179
139	11	S13	0	2.225	4291.579	1121.729	4291.579	9.99+	3.826
140	11	S14	0	241.509	4262.273	832.129	4262.273	9.99+	5.122
141	12	S1	0	137.807	1403.441	1054.626	1403.441	9.99+	1.331
142	12	S2	0	1.983	1434.886	1406.843	1434.886	9.99+	1.02
143	12	S3	0	2.349	1361.083	1336.28	1361.083	9.99+	1.019
144	12	S4	0	0.127	1372.825	1335.201	1372.825	9.99+	1.028
145	12	S5	0	1.569	1371.277	1344.794	1371.277	9.99+	1.02
146	12	S6	0	1.146	1373.413	1327.563	1373.413	9.99+	1.035
147	12	S7	0	0.651	1370.401	1340.528	1370.401	9.99+	1.022
148	12	S8	0	0.652	1370.398	1340.529	1370.398	9.99+	1.022
149	12	S9	0	1.146	1373.411	1327.575	1373.411	9.99+	1.035
150	12	S10	0	1.568	1371.271	1344.784	1371.271	9.99+	1.02
151	12	S11	0	0.128	1372.823	1335.206	1372.823	9.99+	1.028
152	12	S12	0	2.349	1361.078	1336.258	1361.078	9.99+	1.019
153	12	S13	0	1.984	1434.896	1406.825	1434.896	9.99+	1.02
154	12	S14	0	137.807	1403.431	1054.598	1403.431	9.99+	1.331
155	13	S1	0	158.349	1458.965	881.803	1458.965	9.214	1.655
156	13	S2	0	6.718	1557.938	1169.399	1557.938	9.99+	1.332
157	13	S3	0	3.137	1451.525	1117.203	1451.525	9.99+	1.299
158	13	S4	0	0.83	1469.069	1112.592	1469.069	9.99+	1.32
159	13	S5	0	0.255	1465.633	1124.778	1465.633	9.99+	1.303
160	13	S6	0	0.961	1467.872	1104.951	1467.872	9.99+	1.328
161	13	S7	0	0.235	1465.875	1118.997	1465.875	9.99+	1.31
162	13	S8	0	0.236	1465.872	1118.998	1465.872	9.99+	1.31
163	13	S9	0	0.961	1467.867	1104.963	1467.867	9.99+	1.328
164	13	S10	0	0.255	1465.625	1124.769	1465.625	9.99+	1.303
165	13	S11	0	0.83	1469.068	1112.597	1469.068	9.99+	1.32

Slab Stability - Sliding (Continued)

	LC	Slab	Angle[deg]	Va-xx[lb]	Vr-xx[lb]	Va-zz[lb]	Vr-zz[lb]	SR-xx	SR-zz
166	13	S12	0	3.137	1451.519	1117.181	1451.519	9.99+	1.299
167	13	S13	0	6.718	1557.949	1169.376	1557.949	9.99+	1.332
168	13	S14	0	158.348	1458.955	881.776	1458.955	9.214	1.655
169	14	S1	0	184.102	2571.953	1231.347	2571.953	9.99+	2.089
170	14	S2	0	2.316	2531.163	1642.584	2531.163	9.99+	1.541
171	14	S3	0	2.742	2626.934	1560.197	2626.934	9.99+	1.684
172	14	S4	0	0.148	2611.736	1558.937	2611.736	9.99+	1.675
173	14	S5	0	1.832	2613.533	1570.138	2613.533	9.99+	1.665
174	14	S6	0	1.338	2610.741	1550.02	2610.741	9.99+	1.684
175	14	S7	0	0.761	2614.952	1565.158	2614.952	9.99+	1.671
176	14	S8	0	0.761	2614.955	1565.158	2614.955	9.99+	1.671
177	14	S9	0	1.338	2610.744	1550.033	2610.744	9.99+	1.684
178	14	S10	0	1.831	2613.541	1570.126	2613.541	9.99+	1.665
179	14	S11	0	0.149	2611.738	1558.944	2611.738	9.99+	1.675
180	14	S12	0	2.743	2626.94	1560.171	2626.94	9.99+	1.684
181	14	S13	0	2.316	2531.171	1642.563	2531.171	9.99+	1.541
182	14	S14	0	184.102	2571.948	1231.315	2571.948	9.99+	2.089
183	15	S1	0	127.388	2481.664	1111.758	2481.664	9.99+	2.232
184	15	S2	0	2.404	2509.504	1489.188	2509.504	9.99+	1.685
185	15	S3	0	1.433	2556.04	1408.757	2556.04	9.99+	1.814
186	15	S4	0	0.66	2549.216	1410.915	2549.216	9.99+	1.807
187	15	S5	0	2.592	2548.936	1417.328	2548.936	9.99+	1.798
188	15	S6	0	2.26	2546.824	1403.979	2546.824	9.99+	1.814
189	15	S7	0	0.987	2551.074	1414.798	2551.074	9.99+	1.803
190	15	S8	0	0.987	2551.076	1414.799	2551.076	9.99+	1.803
191	15	S9	0	2.26	2546.825	1403.989	2546.825	9.99+	1.814
192	15	S10	0	2.592	2548.941	1417.317	2548.941	9.99+	1.798
193	15	S11	0	0.66	2549.218	1410.921	2549.218	9.99+	1.807
194	15	S12	0	1.434	2556.043	1408.737	2556.043	9.99+	1.814
195	15	S13	0	2.404	2509.513	1489.176	2509.513	9.99+	1.685
196	15	S14	0	127.388	2481.66	1111.732	2481.66	9.99+	2.232



JOB NO.: U2716.0385.241

PROJECT: Sunturf Package A16 Ground Mount

ANCHORAGE DESIGN FOR CONCRETE BALLAST BLOCK

Load Combinations

	Description	Solve	P-Delta	BLC	Factor	BLC	Factor	BLC	Factor	BLC	Factor
1	ASD Loads		Y								
2	1.0 D		Y	DL	1						
3	1.0 D + 1.0 S		Y	DL	1	RLL	1				
4	1.0 D + 0.6 W1		Y	DL	1	RLL		OL1	0.6	WLZ	0.6
5	1.0 D + 0.6 W2		Y	DL	1	RLL		OL2	0.6	WLZ	0.6
6	1.0 D + 0.6 W3		Y	DL	1	RLL		OL3	0.6	WLZ	-0.6
7	1.0 D + 0.6 W4		Y	DL	1	RLL		OL4	0.6	WLZ	-0.6
8	1.0 D + 0.45 W1 + 0.75 S		Y	DL	1	RLL	0.75	OL1	0.45	WLZ	0.45
9	1.0 D + 0.45 W2 + 0.75 S		Y	DL	1	RLL	0.75	OL2	0.45	WLZ	0.45
10	1.0 D + 0.45 W3 + 0.75 S		Y	DL	1	RLL	0.75	OL3	0.45	WLZ	-0.45
11	1.0 D + 0.45 W4 + 0.75 S		Y	DL	1	RLL	0.75	OL4	0.45	WLZ	-0.45
12	0.6 D + 0.6 W1		Y	DL	0.6	RLL		OL1	0.6	WLZ	0.6
13	0.6 D + 0.6 W2		Y	DL	0.6	RLL		OL2	0.6	WLZ	0.6
14	0.6 D + 0.6 W3		Y	DL	0.6	RLL		OL3	0.6	WLZ	-0.6
15	0.6 D + 0.6 W4		Y	DL	0.6	RLL		OL4	0.6	WLZ	-0.6
16			Y								
17	LRFD Loads		Y								
18	1.4 D	Yes	Y	DL	1.4	RLL					
19	1.2 D + 1.6 S + 0.5 W1	Yes	Y	DL	1.2	RLL	1.6	OL1	0.5		
20	1.2 D + 1.6 S + 0.5 W2	Yes	Y	DL	1.2	RLL	1.6	OL2	0.5		
21	1.2 D + 1.6 S + 0.5 W3	Yes	Y	DL	1.2	RLL	1.6	OL3	0.5		
22	1.2 D + 1.6 S + 0.5 W4	Yes	Y	DL	1.2	RLL	1.6	OL4	0.5		
23	1.2 D + 1.0 W1	Yes	Y	DL	1.2	RLL		OL1	1		
24	1.2 D + 1.0 W2	Yes	Y	DL	1.2	RLL		OL2	1		
25	1.2 D + 1.0 W3	Yes	Y	DL	1.2	RLL		OL3	1		
26	1.2 D + 1.0 W4	Yes	Y	DL	1.2	RLL		OL4	1		
27	0.9 D + 1.0 W1	Yes	Y	DL	0.9	RLL		OL1	1		
28	0.9 D + 1.0 W2	Yes	Y	DL	0.9	RLL		OL2	1		
29	0.9 D + 1.0 W3	Yes	Y	DL	0.9	RLL		OL3	1		
30	0.9 D + 1.0 W4	Yes	Y	DL	0.9	RLL		OL4	1		

Envelope Node Reactions

Node Label	X [lb]	LC	Y [lb]	LC	Z [lb]	LC	MX [lb-ft]	LC	MY [lb-ft]	LC	MZ [lb-ft]	LC
1 N2 max	60.091	22	2698.693	20	169.29	23	0	30	0	30	0	30
2 min	-22.721	27	-428.567	29	-198.167	25	0	18	0	18	0	18
3 N1 max	399.548	21	4700.451	21	2248.43	25	0	30	0	30	0	30
4 min	-263.514	28	-3677.612	28	-1928.177	23	0	18	0	18	0	18
5 N151 max	263.549	28	4689.964	21	2248.33	25	0	30	0	30	0	30
6 min	-399.265	21	-3677.969	28	-1928.11	23	0	18	0	18	0	18
7 N152 max	22.689	27	2709.706	20	169.287	23	0	30	0	30	0	30
8 min	-60.96	22	-427.995	29	-198.163	25	0	18	0	18	0	18
9 N276 max	9.992	21	4183.852	25	2965.673	25	0	30	0	30	0	30
10 min	-6.961	28	-3506.019	28	-2534.995	23	0	18	0	18	0	18
11 N278 max	2.299	27	3491.894	20	192.455	23	0	30	0	30	0	30
12 min	-11.03	22	-579.406	29	-224.393	25	0	18	0	18	0	18
13 N239 max	2.055	28	4968.217	21	2825.275	25	0	30	0	30	0	30
14 min	-2.899	21	-4058.201	28	-2423.768	23	0	18	0	18	0	18
15 N241 max	3.063	28	3367.013	20	195.115	23	0	30	0	30	0	30
16 min	-2.727	25	-586.638	29	-227.267	25	0	18	0	18	0	18
17 N245 max	2.504	21	4825.224	21	2827.633	25	0	30	0	30	0	30
18 min	-1.619	28	-3930.704	28	-2420.354	23	0	18	0	18	0	18
19 N247 max	5.306	20	3360.624	20	195.68	23	0	30	0	30	0	30
20 min	-1.387	29	-544.228	29	-228.484	25	0	18	0	18	0	18
21 N251 max	2.608	21	4854.475	21	2845.506	25	0	30	0	30	0	30

Envelope Node Reactions (Continued)

Node Label		X [lb]	LC	Y [lb]	LC	Z [lb]	LC	MX [lb-ft]	LC	MY [lb-ft]	LC	MZ [lb-ft]	LC
22		min	28	-3977.474	28	-2438.009	23	0	18	0	18	0	18
23	N253	max	22	3367.549	20	196.414	23	0	30	0	30	0	30
24		min	27	-579.072	29	-228.976	25	0	18	0	18	0	18
25	N257	max	28	4817.756	21	2811.734	25	0	30	0	30	0	30
26		min	21	-3922.354	28	-2407.907	23	0	18	0	18	0	18
27	N259	max	29	3341.171	20	195.361	23	0	30	0	30	0	30
28		min	20	-540.653	29	-228.164	25	0	18	0	18	0	18
29	N263	max	28	4860.371	21	2837.315	25	0	30	0	30	0	30
30		min	21	-3970.472	28	-2430.302	23	0	18	0	18	0	18
31	N265	max	27	3376.84	20	196.076	23	0	30	0	30	0	30
32		min	22	-566.757	29	-228.757	25	0	18	0	18	0	18
33	N269	max	21	4860.383	21	2837.284	25	0	30	0	30	0	30
34		min	28	-3970.464	28	-2430.278	23	0	18	0	18	0	18
35	N271	max	20	3376.826	20	196.075	23	0	30	0	30	0	30
36		min	27	-566.726	29	-228.755	25	0	18	0	18	0	18
37	N275	max	21	4817.698	21	2811.689	25	0	30	0	30	0	30
38		min	28	-3922.312	28	-2407.871	23	0	18	0	18	0	18
39	N445	max	20	3341.169	20	195.359	23	0	30	0	30	0	30
40		min	29	-540.609	29	-228.162	25	0	18	0	18	0	18
41	N449	max	28	4854.549	21	2845.478	25	0	30	0	30	0	30
42		min	21	-3977.472	28	-2437.988	23	0	18	0	18	0	18
43	N451	max	27	3367.511	20	196.413	23	0	30	0	30	0	30
44		min	22	-579.035	29	-228.976	25	0	18	0	18	0	18
45	N455	max	28	4825.061	21	2827.682	25	0	30	0	30	0	30
46		min	21	-3930.769	28	-2420.381	23	0	18	0	18	0	18
47	N457	max	29	3360.825	20	195.682	23	0	30	0	30	0	30
48		min	20	-544.262	29	-228.487	25	0	18	0	18	0	18
49	N461	max	21	4969.71	21	2825.324	25	0	30	0	30	0	30
50		min	28	-4058.243	28	-2423.838	23	0	18	0	18	0	18
51	N463	max	25	3365.874	20	195.119	23	0	30	0	30	0	30
52		min	28	-586.719	29	-227.27	25	0	18	0	18	0	18
53	N421	max	28	4183.486	25	2965.713	25	0	30	0	30	0	30
54		min	21	-3506.206	28	-2534.993	23	0	18	0	18	0	18
55	N423	max	22	3499.5	20	192.458	23	0	30	0	30	0	30
56		min	27	-579.104	29	-224.399	25	0	18	0	18	0	18
57	Totals:	max	22	97420.694	21	35594.647	29						
58		min	27	-39430.772	27	-30486.187	23						



Company:	Vector Structural Engineers	Date:	3/20/2024
Engineer:	CJT	Page:	1/6
Project:	Sunturf Ground Mount A16		
Address:			
Phone:			
E-mail:			

1. Project information

Customer company: SunModo
 Customer contact name:
 Customer e-mail:
 Comment:

Project description:
 Location:
 Fastening description: Anchorage to concrete ballast block

2. Input Data & Anchor Parameters

General

Design method: ACI 318-19
 Units: Imperial units

Anchor Information:

Anchor type: Bonded anchor
 Material: F593 304/316SS
 Diameter (inch): 0.375
 Effective Embedment depth, h_{ef} (inch): 6.000
 Code report: ICC-ES ESR-4057
 Anchor category: -
 Anchor ductility: Yes
 h_{min} (inch): 7.25
 c_{ac} (inch): 10.99
 C_{min} (inch): 1.75
 S_{min} (inch): 1.00

Base Material

Concrete: Normal-weight
 Concrete thickness, h (inch): 32.00
 State: Cracked
 Compressive strength, f'_c (psi): 2500
 $\Psi_{c,v}$: 1.0
 Reinforcement condition: Supplementary reinforcement not present
 Supplemental edge reinforcement: Not applicable
 Reinforcement provided at corners: No
 Ignore concrete breakout in tension: No
 Ignore concrete breakout in shear: No
 Hole condition: Dry concrete
 Inspection: Periodic
 Temperature range, Short/Long: 150/110°F
 Reduced installation torque (for AT-3G): Not applicable
 Ignore 6do requirement: Not applicable
 Build-up grout pad: No

Base Plate

Length x Width x Thickness (inch): 4.75 x 4.75 x 0.31

Recommended Anchor

Anchor Name: SET-3G™ - SET-3G w/ 3/8"Ø F593 CW (304/316SS)
 Code Report: ICC-ES ESR-4057





Company:	Vector Structural Engineers	Date:	3/20/2024
Engineer:	CJT	Page:	2/6
Project:	Sunturf Ground Mount A16		
Address:			
Phone:			
E-mail:			

Load and Geometry

Load factor source: ACI 318 Section 5.3

Load combination: not set

Seismic design: No

Anchors subjected to sustained tension: No

Apply entire shear load at front row: No

Anchors only resisting wind and/or seismic loads: No

Strength level loads:

N_{ua} [lb]: 4059

V_{uax} [lb]: 400

V_{uay} [lb]: 2966

M_{ux} [ft-lb]: 0

M_{uy} [ft-lb]: 0

M_{uz} [ft-lb]: 0

<Figure 1>

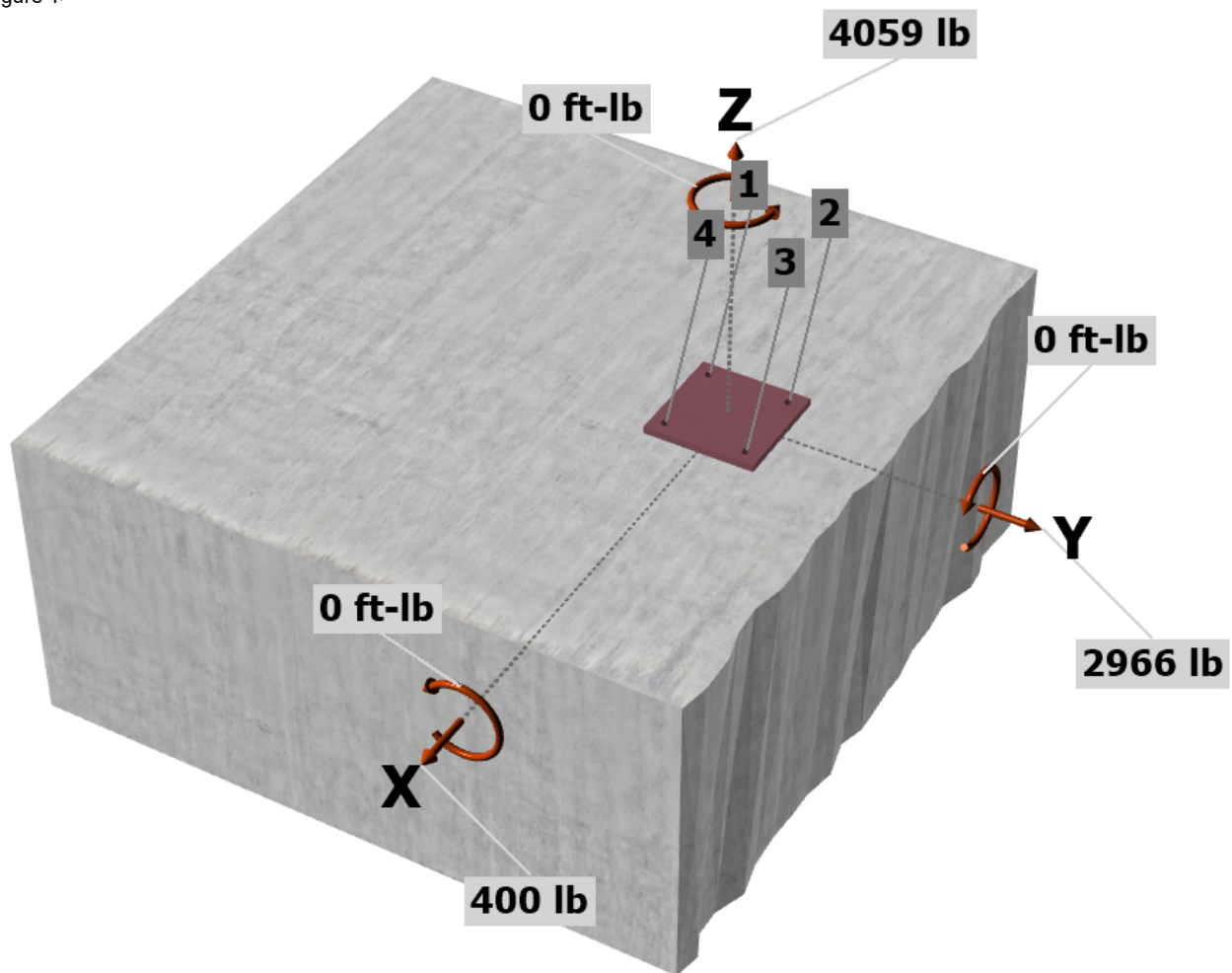

Input data and results must be checked for agreement with the existing circumstances, the standards and guidelines must be checked for plausibility.



Anchor Designer™
Software
Version 3.1.2303.1

Company:	Vector Structural Engineers	Date:	3/20/2024
Engineer:	CJT	Page:	3/6
Project:	Sunturf Ground Mount A16		
Address:			
Phone:			
E-mail:			

<Figure 2>

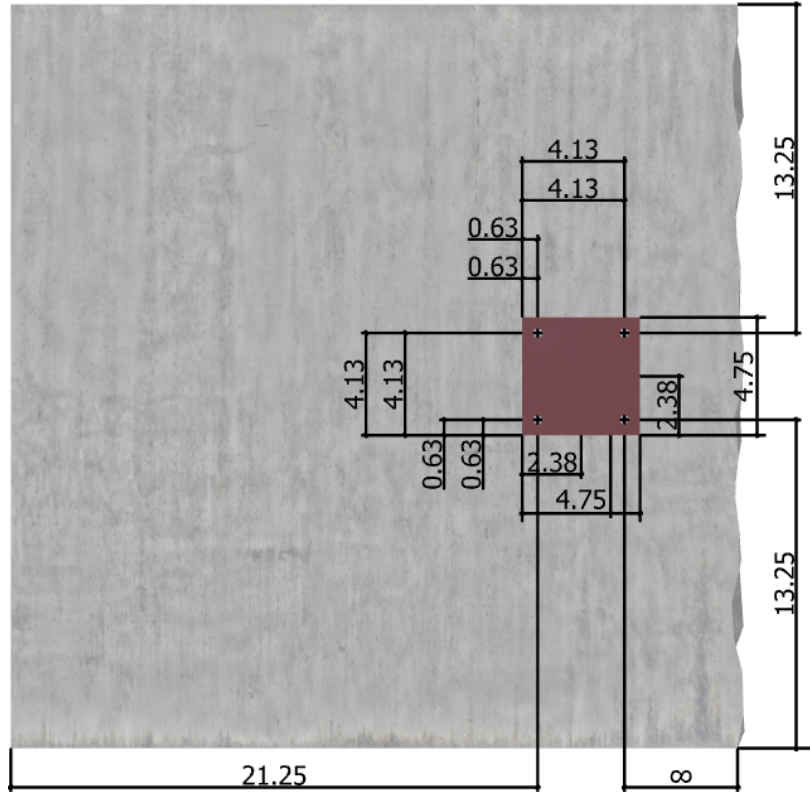



Company:	Vector Structural Engineers	Date:	3/20/2024
Engineer:	CJT	Page:	4/6
Project:	Sunturf Ground Mount A16		
Address:			
Phone:			
E-mail:			

3. Resulting Anchor Forces

Anchor	Tension load, N_{ua} (lb)	Shear load x, V_{uax} (lb)	Shear load y, V_{uay} (lb)	Shear load combined, $\sqrt{(V_{uax})^2 + (V_{uay})^2}$ (lb)
1	1014.8	100.0	741.5	748.3
2	1014.8	100.0	741.5	748.3
3	1014.8	100.0	741.5	748.2
4	1014.8	100.0	741.5	748.2
Sum	4059.0	400.0	2966.0	2992.9

Maximum concrete compression strain (%): 0.00
 Maximum concrete compression stress (psi): 0
 Resultant tension force (lb): 4059
 Resultant compression force (lb): 0
 Eccentricity of resultant tension forces in x-axis, e'_{Nx} (inch): 0.00
 Eccentricity of resultant tension forces in y-axis, e'_{Ny} (inch): 0.00
 Eccentricity of resultant shear forces in x-axis, e'_{Vx} (inch): 0.00
 Eccentricity of resultant shear forces in y-axis, e'_{Vy} (inch): 0.00

<Figure 3>

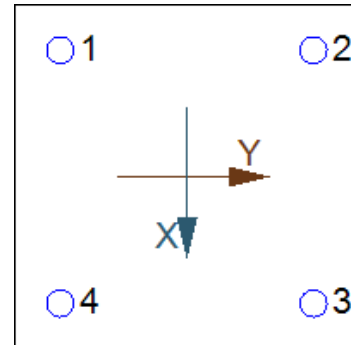

4. Steel Strength of Anchor in Tension (Sec. 17.6.1)

N_{sa} (lb)	ϕ	ϕN_{sa} (lb)
7800	0.75	5850

5. Concrete Breakout Strength of Anchor in Tension (Sec. 17.6.2)

$N_b = K_c \lambda_a \sqrt{f_c} h_{ef}^{1.5}$ (Eq. 17.6.2.2.1)

K_c	λ_a	f_c (psi)	h_{ef} (in)	N_b (lb)
17.0	1.00	2500	6.000	12492

$\phi N_{cbg} = \phi (A_{Nc} / A_{Nco}) \Psi_{ec,N} \Psi_{ed,N} \Psi_{c,N} \Psi_{cp,N} N_b$ (Sec. 17.5.1.2 & Eq. 17.6.2.1a)

A_{Nc} (in ²)	A_{Nco} (in ²)	$C_{a,min}$ (in)	$\Psi_{ec,N}$	$\Psi_{ed,N}$	$\Psi_{c,N}$	$\Psi_{cp,N}$	N_b (lb)	ϕ	ϕN_{cbg} (lb)
462.25	324.00	13.25	1.000	1.000	1.00	1.000	12492	0.65	11585

6. Adhesive Strength of Anchor in Tension (Sec. 17.6.5)

$\tau_{k,cr} = \tau_{k,cr,short-term} K_{sat} (f_c / 2,500)^0$

$\tau_{k,cr}$ (psi)	$f_{short-term}$	K_{sat}	f_c (psi)	n	$\tau_{k,cr}$ (psi)
1346	1.00	1.00	2500	0.24	1346

$N_{ba} = \lambda_a \tau_{cr} \pi d_a h_{ef}$ (Eq. 17.6.5.2.1)

λ_a	τ_{cr} (psi)	d_a (in)	h_{ef} (in)	N_{ba} (lb)
1.00	1346	0.38	6.000	9514

$\phi N_{ag} = \phi (A_{Na} / A_{Na0}) \Psi_{ec,Na} \Psi_{ed,Na} \Psi_{cp,Na} N_{ba}$ (Sec. 17.5.1.2 & Eq. 17.6.5.1b)

A_{Na} (in ²)	A_{Na0} (in ²)	C_{Na} (in)	$C_{a,min}$ (in)	$\Psi_{ec,Na}$	$\Psi_{ed,Na}$	$\Psi_{cp,Na}$	N_{ba} (lb)	ϕ	ϕN_{ag} (lb)
198.45	112.09	5.29	13.25	1.000	1.000	1.000	9514	0.55	9265

Input data and results must be checked for agreement with the existing circumstances, the standards and guidelines must be checked for plausibility.



Company:	Vector Structural Engineers	Date:	3/20/2024
Engineer:	CJT	Page:	5/6
Project:	Sunturf Ground Mount A16		
Address:			
Phone:			
E-mail:			

8. Steel Strength of Anchor in Shear (Sec. 17.7.1)

V_{sa} (lb)	ϕ_{grout}	ϕ	$\phi_{grout}\phi V_{sa}$ (lb)
4680	1.0	0.65	3042

9. Concrete Breakout Strength of Anchor in Shear (Sec. 17.7.2)

Shear perpendicular to edge in x-direction:

$$V_{bx} = \min|7(l_e / d_a)^{0.2} \sqrt{d_a} \lambda_a \sqrt{f_c} c_{a1}^{1.5}; 9 \lambda_a \sqrt{f_c} c_{a1}^{1.5}| \text{ (Eq. 17.7.2.2.1a \& Eq. 17.7.2.2.1b)}$$

l_e (in)	d_a (in)	λ_a	f_c (psi)	c_{a1} (in)	V_{bx} (lb)
3.00	0.375	1.00	2500	16.75	22270

$$\phi V_{cbgx} = \phi (A_{vc} / A_{vco}) \psi_{ec,v} \psi_{ed,v} \psi_{c,v} \psi_{h,v} V_{bx} \text{ (Sec. 17.5.1.2 \& Eq. 17.7.2.1b)}$$

A_{vc} (in ²)	A_{vco} (in ²)	$\psi_{ec,v}$	$\psi_{ed,v}$	$\psi_{c,v}$	$\psi_{h,v}$	V_{bx} (lb)	ϕ	ϕV_{cbgx} (lb)
1253.11	1262.53	1.000	0.954	1.000	1.000	22270	0.70	14756

Shear parallel to edge in y-direction:

$$V_{bx} = \min|7(l_e / d_a)^{0.2} \sqrt{d_a} \lambda_a \sqrt{f_c} c_{a1}^{1.5}; 9 \lambda_a \sqrt{f_c} c_{a1}^{1.5}| \text{ (Eq. 17.7.2.2.1a \& Eq. 17.7.2.2.1b)}$$

l_e (in)	d_a (in)	λ_a	f_c (psi)	c_{a1} (in)	V_{bx} (lb)
3.00	0.375	1.00	2500	21.25	31823

$$\phi V_{cbgy} = \phi (2)(A_{vc} / A_{vco}) \psi_{ec,v} \psi_{ed,v} \psi_{c,v} \psi_{h,v} V_{bx} \text{ (Sec. 17.5.1.2, 17.7.2.1(c) \& Eq. 17.7.2.1b)}$$

A_{vc} (in ²)	A_{vco} (in ²)	$\psi_{ec,v}$	$\psi_{ed,v}$	$\psi_{c,v}$	$\psi_{h,v}$	V_{bx} (lb)	ϕ	ϕV_{cbgy} (lb)
956.25	2032.03	1.000	1.000	1.000	1.000	31823	0.70	20966

Shear parallel to edge in x-direction:

$$V_{by} = \min|7(l_e / d_a)^{0.2} \sqrt{d_a} \lambda_a \sqrt{f_c} c_{a1}^{1.5}; 9 \lambda_a \sqrt{f_c} c_{a1}^{1.5}| \text{ (Eq. 17.7.2.2.1a \& Eq. 17.7.2.2.1b)}$$

l_e (in)	d_a (in)	λ_a	f_c (psi)	c_{a1} (in)	V_{by} (lb)
3.00	0.375	1.00	2500	13.25	15668

$$\phi V_{cbgx} = \phi (2)(A_{vc} / A_{vco}) \psi_{ec,v} \psi_{ed,v} \psi_{c,v} \psi_{h,v} V_{by} \text{ (Sec. 17.5.1.2, 17.7.2.1(c) \& Eq. 17.7.2.1b)}$$

A_{vc} (in ²)	A_{vco} (in ²)	$\psi_{ec,v}$	$\psi_{ed,v}$	$\psi_{c,v}$	$\psi_{h,v}$	V_{by} (lb)	ϕ	ϕV_{cbgx} (lb)
859.59	790.03	1.000	1.000	1.000	1.000	15668	0.70	23867

10. Concrete Pryout Strength of Anchor in Shear (Sec. 17.7.3)

$$\phi V_{cp} = \phi \min|k_{cp} N_{ag}; k_{cp} N_{cbg}| = \phi \min|k_{cp} (A_{Na} / A_{Na0}) \psi_{ec,Na} \psi_{ed,Na} \psi_{cp,Na} N_{ba}; k_{cp} (A_{Nc} / A_{Nco}) \psi_{ec,N} \psi_{ed,N} \psi_{c,N} \psi_{cp,N} N_b| \text{ (Sec. 17.5.1.2 \& Eq. 17.7.3.1b)}$$

k_{cp}	A_{Na} (in ²)	A_{Na0} (in ²)	$\psi_{ed,Na}$	$\psi_{ec,Na}$	$\psi_{cp,Na}$	N_{ba} (lb)	N_a (lb)
2.0	198.45	112.09	1.000	1.000	1.000	9514	16844

A_{Nc} (in ²)	A_{Nco} (in ²)	$\psi_{ec,N}$	$\psi_{ed,N}$	$\psi_{c,N}$	$\psi_{cp,N}$	N_b (lb)	N_{cb} (lb)	ϕ
462.25	324.00	1.000	1.000	1.000	1.000	12492	17822	0.70

$$\phi V_{cp} \text{ (lb)}$$

23581

11. Results

Interaction of Tension and Shear Forces (Sec. 17.8)

Tension	Factored Load, N_{ua} (lb)	Design Strength, ϕN_n (lb)	Ratio	Status
---------	------------------------------	----------------------------------	-------	--------

Input data and results must be checked for agreement with the existing circumstances, the standards and guidelines must be checked for plausibility.



Anchor Designer™
Software
Version 3.1.2303.1

Company:	Vector Structural Engineers	Date:	3/20/2024
Engineer:	CJT	Page:	6/6
Project:	Sunturf Ground Mount A16		
Address:			
Phone:			
E-mail:			

Steel	1015	5850	0.17	Pass
Concrete breakout	4059	11585	0.35	Pass
Adhesive	4059	9265	0.44	Pass (Governs)

Shear	Factored Load, V_{ua} (lb)	Design Strength, ϕV_n (lb)	Ratio	Status
Steel	748	3042	0.25	Pass (Governs)
T Concrete breakout x+	400	14756	0.03	Pass
Concrete breakout y-	200	20966	0.01	Pass
Concrete breakout x-	1483	23867	0.06	Pass
Concrete breakout, combined	-	-	0.06	Pass
Pryout	2993	23581	0.13	Pass

Interaction check	$N_{ua}/\phi N_n$	$V_{ua}/\phi V_n$	Combined Ratio	Permissible	Status
Sec. 17.8.1	0.44	0.00	43.8%	1.0	Pass

SET-3G w/ 3/8"Ø F593 CW (304/316SS) with hef = 6.000 inch meets the selected design criteria.

12. Warnings

- Designer must exercise own judgement to determine if this design is suitable.
- Refer to manufacturer's product literature for hole cleaning and installation instructions.