



Project Number: U2716.0385.241

June 13, 2024

Sunmodo  
14800 NE 65<sup>th</sup> Street  
Vancouver, WA 98682

**REFERENCE: SunModo Sunturf Ground Mount A16 – Large Format Panels  
Ground Mount PV Array Installation**

To Whom It May Concern:

Per request of SunModo, we have been asked to prepare the structural design of a ground-mounted PV solar array system with several foundation options as shown in the attached calculations. The adopted building code in this jurisdiction is the 2021 Washington State Building Code (2021 IBC). Vector Structural Engineering requires that we review each site-specific install, and we are not liable for installs at site-specific locations we have not reviewed. This document does not address site-specific installations. The following design parameters are used in our analysis:

- Minimum Design Loads for Buildings and Other Structures (ASCE 7-22)
- Design wind speed for risk category I structures: 140 mph
- Wind exposure: C
- Ground snow load: 70 psf
- The ground screws and helical piers must be tested to 1.5 times uplift and 2.0 times lateral reactions found in the table below. A minimum of one ground screw or helical pier must be tested.

Load (ASD)	Value (lbs)	Factor of Safety	Test Value (lbs)
UPLIFT	2583	1.5	3875
LATERAL	1934	2	3868

Foundation concrete shall have a minimum compressive strength of 2500 psi at 28 days. Cement for all concrete shall be Type I or II with a water/cement ratio of 0.50. Maximum aggregate size shall be 3/4". No special inspection of concrete strength is required.

Footings are designed based on an allowable soil bearing pressure of 1500 psf an allowable skin friction of 250 psf, an allowable lateral bearing pressure of 150 pcf, and a coefficient of friction of 0.3. Vector Structural Engineering strongly recommends independent soils testing be performed by a licensed geotechnical engineer to verify the assumed soil parameters.

All ground mounts are to be installed per manufacturer’s recommendations. The use of solar panel support span tables provided by the manufacturer is allowed only where the site conditions and solar panel configuration match the description of the span tables. Electrical engineering is beyond our scope. All work performed must be in accordance with accepted industry-wide methods and applicable safety standards. Vector Structural Engineering assumes no responsibility for improper installation of the solar panels.

Very truly yours,

VECTOR STRUCTURAL ENGINEERING, LLC  
Firm License: 2202

\_\_\_\_\_  
Wells Holmes, S.E.  
License: 51006 - Expires: 10/06/2024  
Project Engineer

Enclosures

WLH/reh

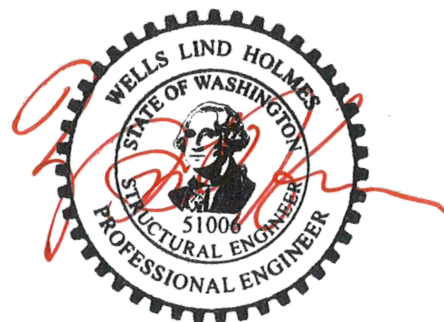

06/13/2024



JOB NO. U2716-0385-241  
 PROJECT SUNMODO SUNTURF GROUND MOUNT A16  
 SUBJECT ALL OPTIONS

651 W GALENA PARK BLVD. #101 (801) 990-1775  
 DRAPER, UTAH 84020 (801) 990-1776 FAX

Vector Structural Engineering requires that we review each site-specific install, and we are not liable for installs at site-specific locations we have not reviewed. This document does not address site-specific installations.



06/13/2024

NOTES:

- SEE SUNMODO SHOP DRAWINGS FOR GROUND MOUNT MEMBER SIZES, GEOMETRY, AND POST SPACING

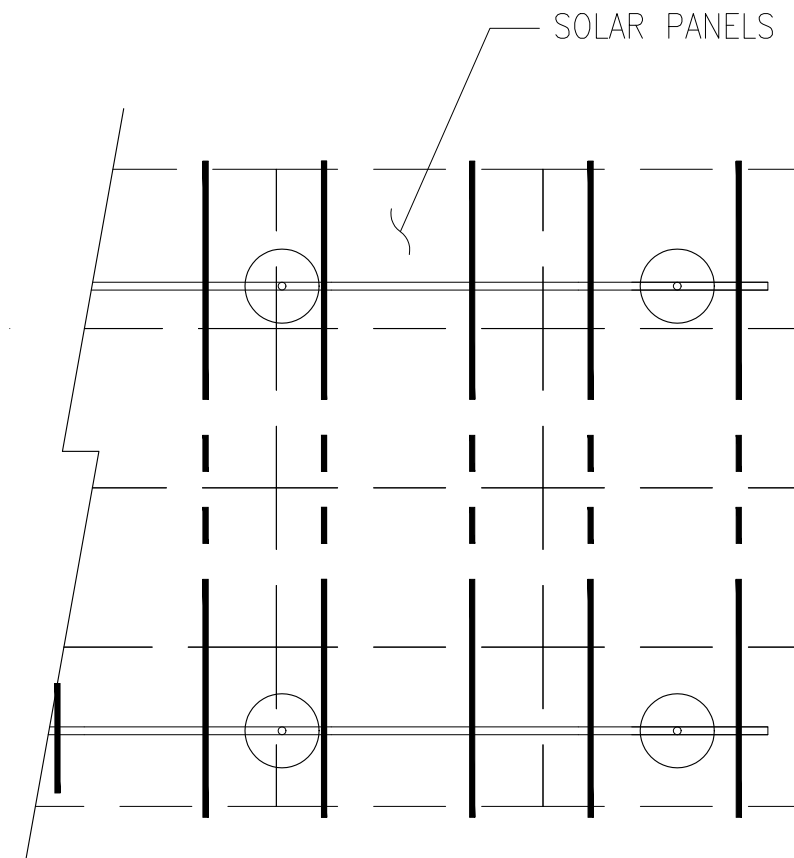
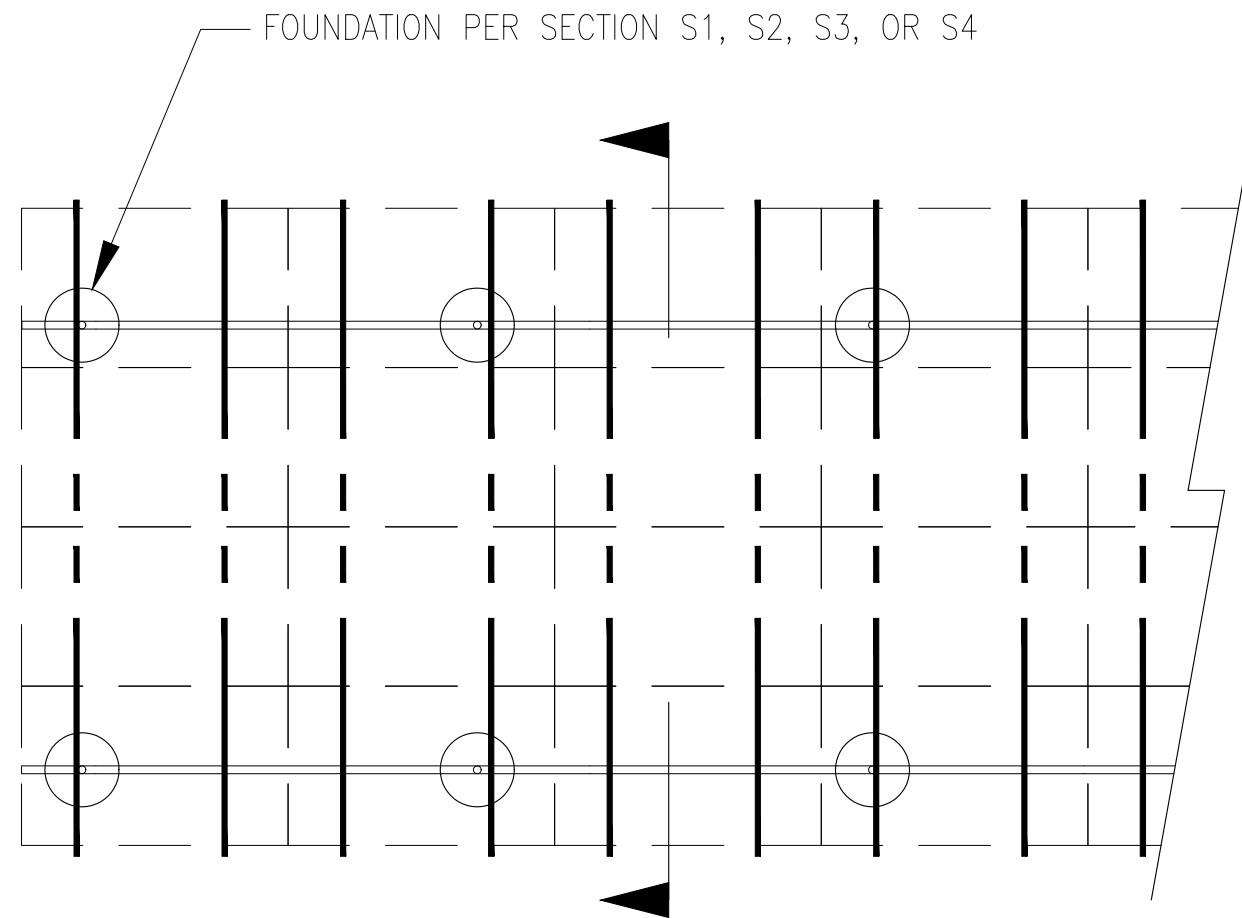

**PV ARRAY PLAN**

N.T.S.

**P1**

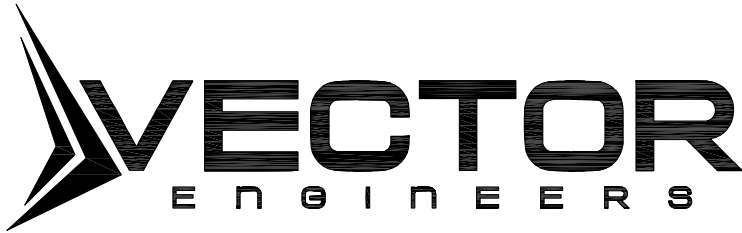

JOB NO. U2716-0385-241

PROJECT SUNMODO SUNTURF GROUND MOUNT A16

SUBJECT DRILLED PIER OPTION

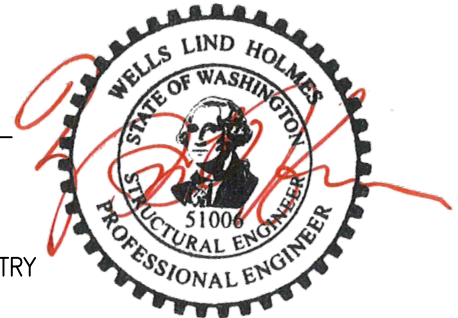

06/13/2024

NOTES:

- 1. SEE SUNMODO SHOP DRAWINGS FOR GROUND MOUNT MEMBER SIZES AND GEOMETRY

Vector Structural Engineering requires that we review each site-specific install, and we are not liable for installs at site-specific locations we have not reviewed. This document does not address site-specific installations.

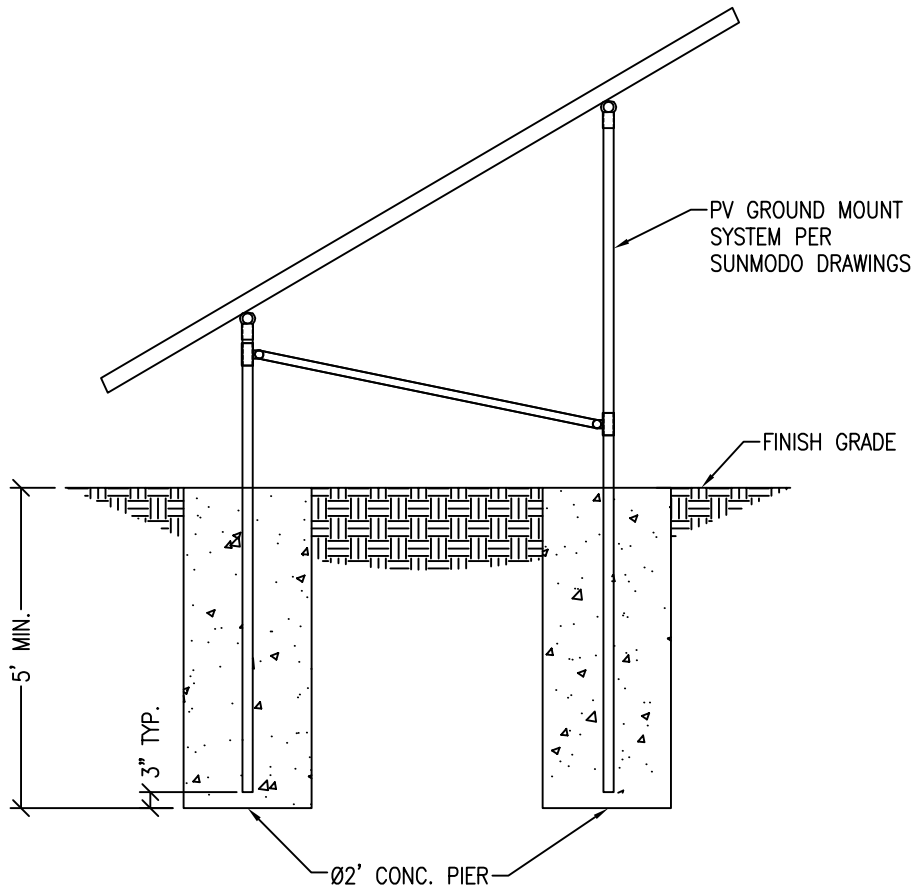

**DRILLED PIER SECTION**

NTS.



PROJECT SUNMODO SUNTURF GROUND MOUNT A16SUBJECT HELICAL PIER OPTION**NOTES:**

1. SEE SUNMODOD SHOP DRAWINGS FOR GROUND MOUNT MEMBER SIZES AND GEOMETRY
2. A MINIMUM OF (1) HELICAL PIER SHALL BE LOAD TESTED PER THE TEST LOADS LISTED ON THE COVER PAGE OF THIS LETTER. FAILURE CRITERIA IS AS FOLLOWS:
  - 2.1. LATERAL DEFLECTION OF 1" MEASURED AT GRADE UNDER LATERAL LOAD
  - 2.2. VERTICAL DEFLECTION OF 1/2" UNDER AXIAL LOAD
3. LOAD TESTS SHALL BE PERFORMED BY A LICENSED CONTRACTOR AS APPROVED BY THE AHJ

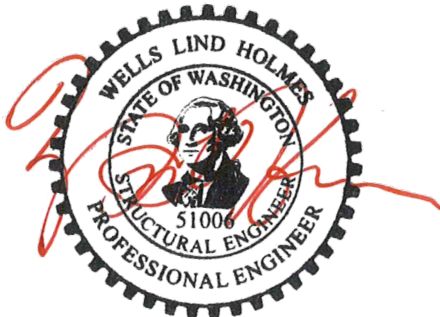

06/13/2024

Vector Structural Engineering requires that we review each site-specific install, and we are not liable for installs at site-specific locations we have not reviewed. This document does not address site-specific installations.

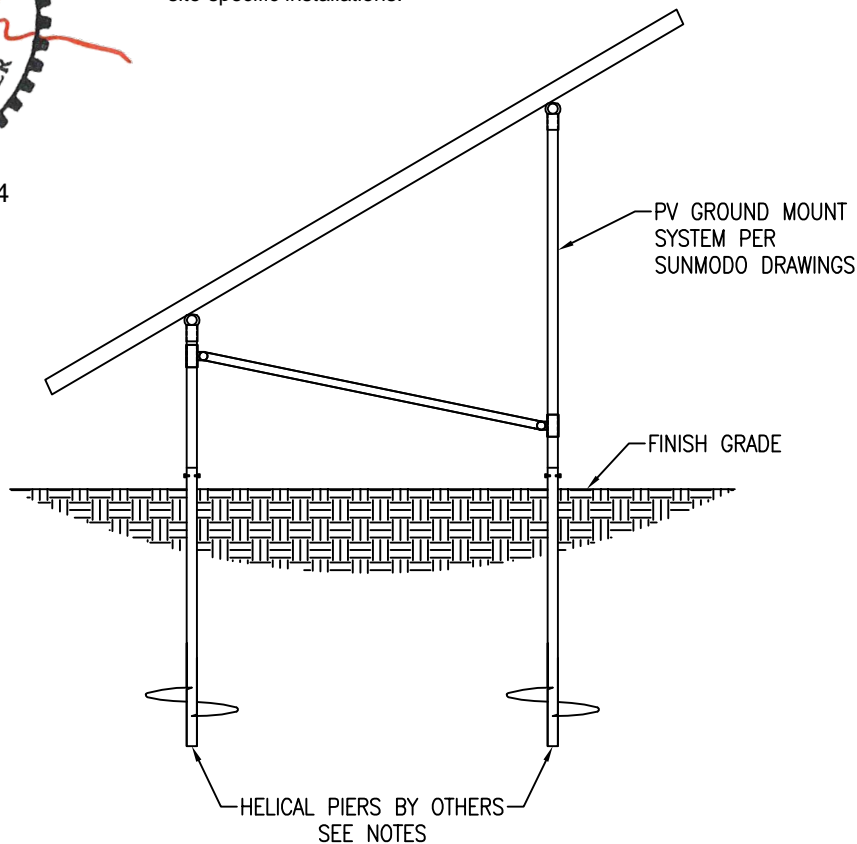
**HELICAL PIER SECTION**

NTS.

**S2**

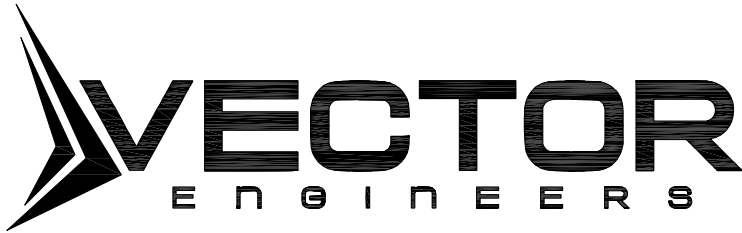

JOB NO. U2716-0385-241

PROJECT SUNMODO SUNTURF GROUND MOUNT A16

SUBJECT GROUND SCREW OPTION

**NOTES:**

1. SEE SUNMODOD SHOP DRAWINGS FOR GROUND MOUNT MEMBER SIZES AND GEOMETRY
2. A MINIMUM OF (1) HELICAL PIER SHALL BE LOAD TESTED PER THE TEST LOADS LISTED ON THE COVER PAGE OF THIS LETTER. FAILURE CRITERIA IS AS FOLLOWS:
  - 2.1. LATERAL DEFLECTION OF 1" MEASURED AT GRADE UNDER LATERAL LOAD
  - 2.2. VERTICAL DEFLECTION OF 1/2" UNDER AXIAL LOAD
3. LOAD TESTS SHALL BE PERFORMED BY A LICENSED CONTRACTOR AS APPROVED BY THE AHJ

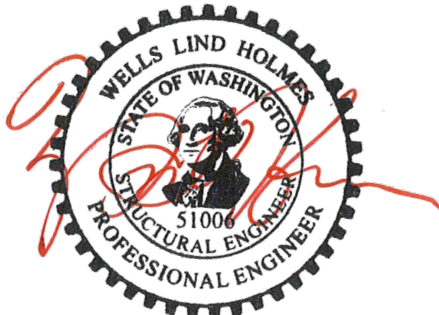

06/13/2024

Vector Structural Engineering requires that we review each site-specific install, and we are not liable for installs at site-specific locations we have not reviewed. This document does not address site-specific installations.

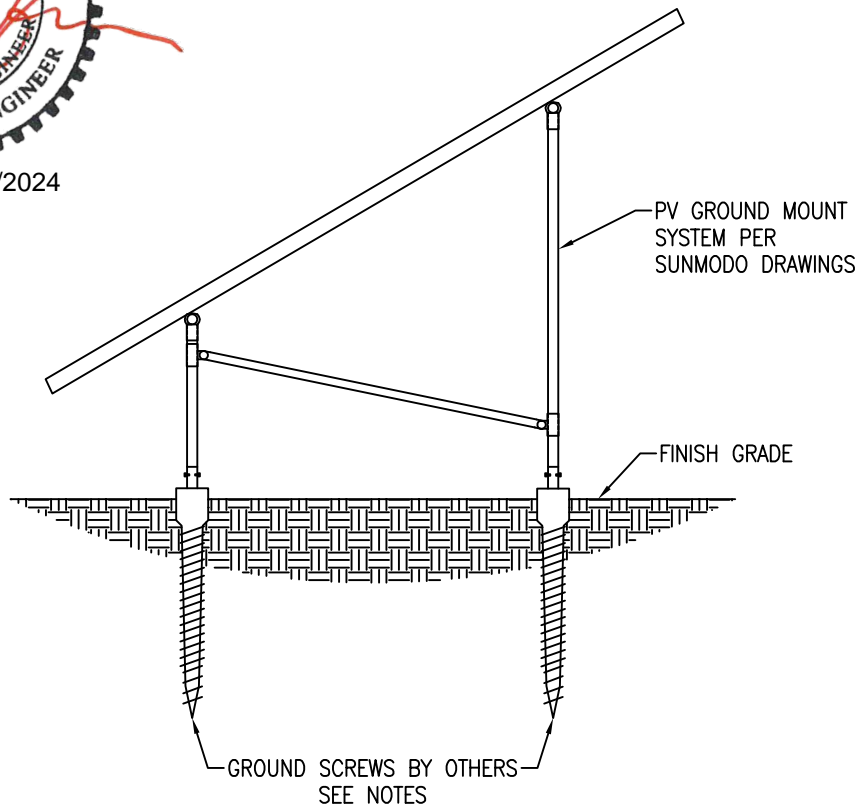

**GROUND SCREW SECTION**

NTS.



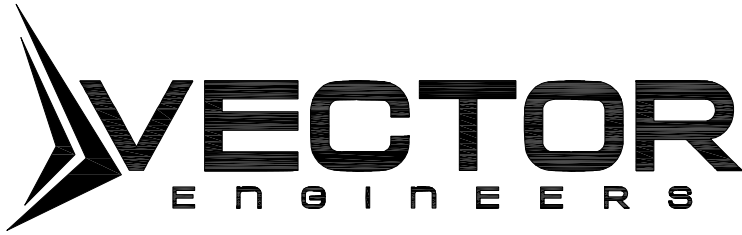

JOB NO. U2716-0385-241

PROJECT SUNMODO SUNTURF GROUND MOUNT A16

SUBJECT BALLAST BLOCK OPTION



06/13/2024

NOTES:

- 1. SEE SUNMODO SHOP DRAWINGS FOR GROUND MOUNT MEMBER SIZES AND GEOMETRY

Vector Structural Engineering requires that we review each site-specific install, and we are not liable for installs at site-specific locations we have not reviewed. This document does not address site-specific installations.

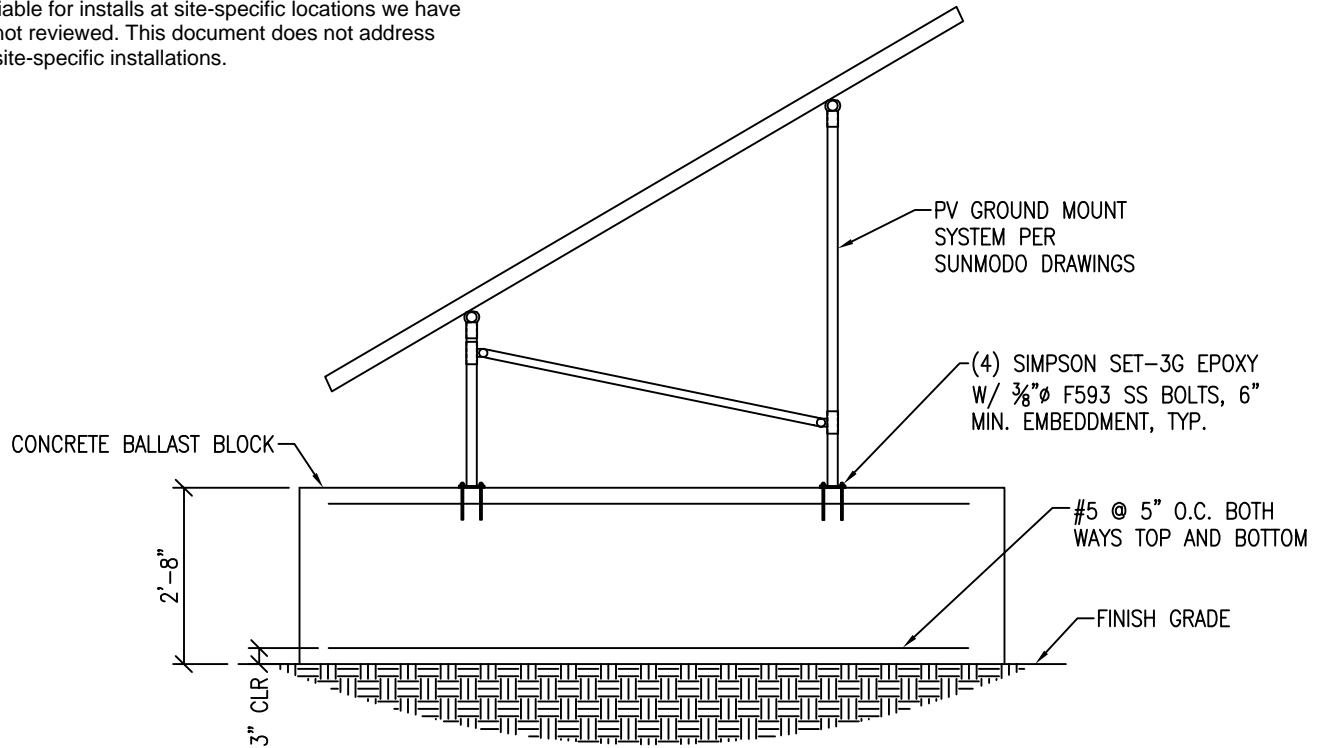

SECTION VIEW

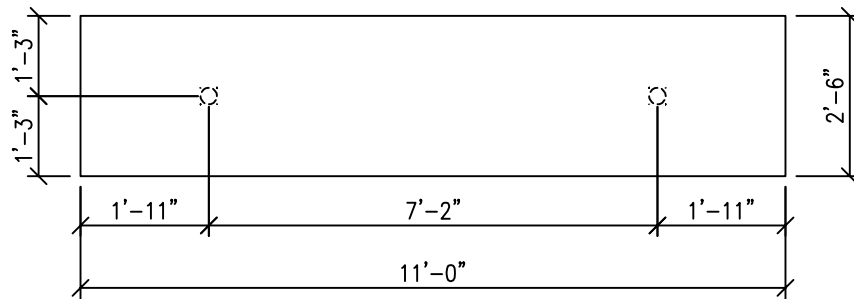

PLAN VIEW

**BALLAST BLOCK SECTION**

NTS.





**PROJECT:** Sunturf Package A16 Ground Mount

**SNOW LOADS**

Calculations Per:	ASCE 7-22	
Snow Ground Load, $p_g$ [psf]:	70.0	(Section 7.2)
Risk Category:	I	(Table 1.5-1)
Terrain Category:	C	(Section 26.7)
Exposure of Roof:	Fully Exposed	(Table 7-2)
Exposure Factor, $C_e$ :	0.9	(Table 7-2)
Thermal Factor, $C_t$ :	1.2	(Table 7-3)
Flat Roof Snow Load, $p_f$ [psf]:	53	(Equation 7.3-1)
Min. Roof Snow Load, $p_m$ [psf]:	25	(Section 7.3.3)
Panel Slope from Horizontal [°]:	20.0	
Unobstructed Slippery Surface?	Yes	(Section 7.4)
Slope Factor Figure:	Figure 7-2c	(Section 7.4)
Roof Slope Factor, $C_s$ :	0.64	
Sloped Roof Snow Load, $p_s$ [psf]:	34	(Equation 7.4-1)
Array Width [ft]	11.0	
Required Leading Edge Height [ft]	3.7	
Leading Edge Height [ft]	3.0	
Design Snow Load, $S$ [psf]:	53	(1.0 Snow)



**PROJECT:** Sunturf Package A16 Ground Mount

**WIND PRESSURES**

Calculations per:	ASCE 7-22	
Design Wind Speed, V [mph]:	140	
Risk Category:	I	(Table 1.5-1)
Exposure Category:	C	(Section 26.7)
Elevation [ft]:	-156.2	
Ground Elevation Factor, $K_e$ :		(Not applicable)
$\alpha$ :	9.8	(Table 26.11-1)
$z_g$ [ft]:	2460	(Table 26.11-1)
Velocity Pressure Exposure Coefficient, $K_h$ :	0.85	(Table 26.10-1)
Topographic Factor, $K_{ht}$ :	1.0	(Section 26.8)
Wind Directionality Factor, $K_d$ :	0.85	(Table 26.6-1)
Internal Pressure Coefficient, $GC_{pi}$ :	0.00	(Figure 26.13-1)
Velocity Pressure, $q_h$ [psf]:	42.71	(Equation 26.10-1)
Gust Effect Factor, G:	0.85	(Section 26.11.4)
Panel Slope [degrees]:	20.0	
Wind Flow:	Clear	
Roof Configuration:	Monoslope	

Wind Pressures in Transverse (N-S) Direction

Net Pressure Coefficients per Figure 27.3-4

Clear Wind Flow	$C_{NW}$	$C_{NL}$
Case 1 ( $\gamma = 0^\circ$ , Load Case A)	-1.3	-1.5
Case 2 ( $\gamma = 0^\circ$ , Load Case B)	-2.2	-0.2
Case 3 ( $\gamma = 180^\circ$ , Load Case A)	1.6	1.7
Case 4 ( $\gamma = 180^\circ$ , Load Case B)	2.1	0.7

Design Wind Pressures per Equation 27.3-2 [psf]

Clear Wind Flow	$k_d q_h GC_{NW}$	$k_d q_h GC_{NL}$
Case 1 ( $\gamma = 0^\circ$ , Load Case A)	-40.1	-46.3
Case 2 ( $\gamma = 0^\circ$ , Load Case B)	-67.9	-6.2
Case 3 ( $\gamma = 180^\circ$ , Load Case A)	49.4	52.5
Case 4 ( $\gamma = 180^\circ$ , Load Case B)	64.8	21.6
Case 5 ( $\gamma = 0^\circ$ , 16 psf Min. Horiz.)	-16.0	-16.0
Case 6 ( $\gamma = 180^\circ$ , 16 psf Min. Horiz.)	16.0	16.0





**PROJECT:** Sunturf Package A16 Ground Mount

---

**SNOW LOADS**

---

Calculations Per:	ASCE 7-22	
Snow Ground Load, $p_g$ [psf]:	70.0	(Section 7.2)
Risk Category:	I	(Table 1.5-1)
Terrain Category:	C	(Section 26.7)
Exposure of Roof:	Fully Exposed	(Table 7-2)
Exposure Factor, $C_e$ :	0.9	(Table 7-2)
Thermal Factor, $C_t$ :	1.2	(Table 7-3)
Flat Roof Snow Load, $p_f$ [psf]:	53	(Equation 7.3-1)
Min. Roof Snow Load, $p_m$ [psf]:	25	(Section 7.3.3)
Panel Slope from Horizontal [°]:	35.0	
Unobstructed Slippery Surface?	Yes	(Section 7.4)
Slope Factor Figure:	Figure 7-2c	(Section 7.4)
Roof Slope Factor, $C_s$ :	0.64	
Sloped Roof Snow Load, $p_s$ [psf]:	34	(Equation 7.4-1)
Array Width [ft]	15.0	
Required Leading Edge Height [ft]	3.9	
Leading Edge Height [ft]	3.0	
Design Snow Load, $S$ [psf]:	53	(1.0 Snow)



**PROJECT:** Sunturf Package A16 Ground Mount

**WIND PRESSURES**

Calculations per:	ASCE 7-22	
Design Wind Speed, V [mph]:	140	
Risk Category:	I	(Table 1.5-1)
Exposure Category:	C	(Section 26.7)
Elevation [ft]:	-156.2	
Ground Elevation Factor, $K_e$ :		(Not applicable)
$\alpha$ :	9.8	(Table 26.11-1)
$z_g$ [ft]:	2460	(Table 26.11-1)
Velocity Pressure Exposure Coefficient, $K_h$ :	0.85	(Table 26.10-1)
Topographic Factor, $K_{ht}$ :	1.0	(Section 26.8)
Wind Directionality Factor, $K_d$ :	0.85	(Table 26.6-1)
Internal Pressure Coefficient, $GC_{pi}$ :	0.00	(Figure 26.13-1)
Velocity Pressure, $q_h$ [psf]:	42.71	(Equation 26.10-1)
Gust Effect Factor, G:	0.85	(Section 26.11.4)
Panel Slope [degrees]:	35.0	
Wind Flow:	Clear	
Roof Configuration:	Monoslope	

Wind Pressures in Transverse (N-S) Direction

Net Pressure Coefficients per Figure 27.3-4

Clear Wind Flow	$C_{NW}$	$C_{NL}$
Case 1 ( $\gamma = 0^\circ$ , Load Case A)	-1.8	-1.8
Case 2 ( $\gamma = 0^\circ$ , Load Case B)	-2.4	-0.6
Case 3 ( $\gamma = 180^\circ$ , Load Case A)	2.1	2.1
Case 4 ( $\gamma = 180^\circ$ , Load Case B)	2.7	1.1

Design Wind Pressures per Equation 27.3-2 [psf]

Clear Wind Flow	$k_d q_h GC_{NW}$	$k_d q_h GC_{NL}$
Case 1 ( $\gamma = 0^\circ$ , Load Case A)	-55.5	-55.5
Case 2 ( $\gamma = 0^\circ$ , Load Case B)	-74.1	-18.5
Case 3 ( $\gamma = 180^\circ$ , Load Case A)	64.8	64.8
Case 4 ( $\gamma = 180^\circ$ , Load Case B)	83.3	33.9
Case 5 ( $\gamma = 0^\circ$ , 16 psf Min. Horiz.)	-16.0	-16.0
Case 6 ( $\gamma = 180^\circ$ , 16 psf Min. Horiz.)	16.0	16.0



JOB NO.: U2716.0385.241

**PROJECT:** Sunturf Package A16 Ground Mount

---

# Framing Analysis

## LF - 20 deg

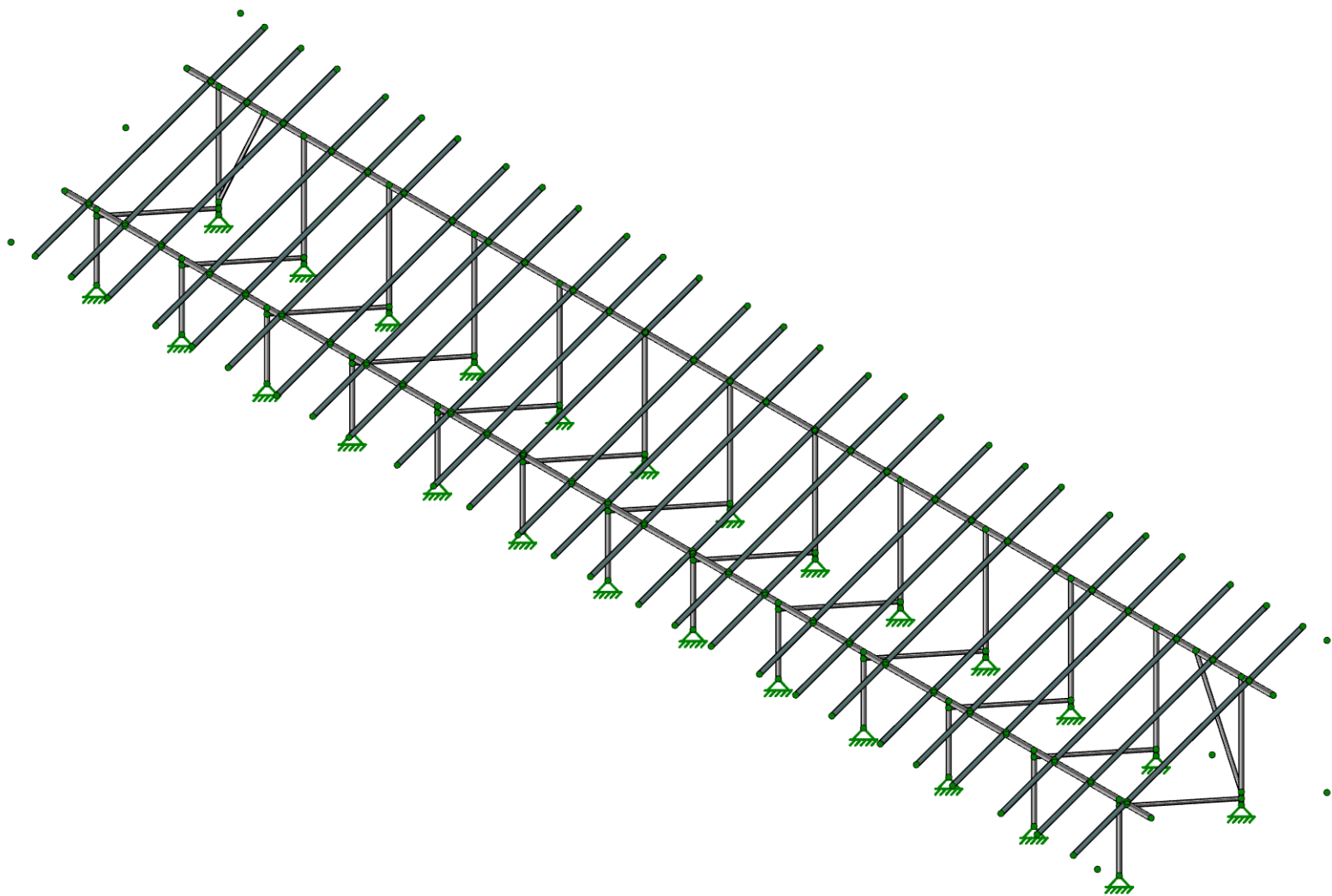
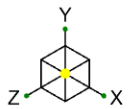

Vector Structural Engineering  
CJT  
U2716.0385.241

A16 Large Format Panels - 20 Degree Tilt

SK-1  
Mar 20, 2024  
Sunturf A16 - LF - 20deg.r3d

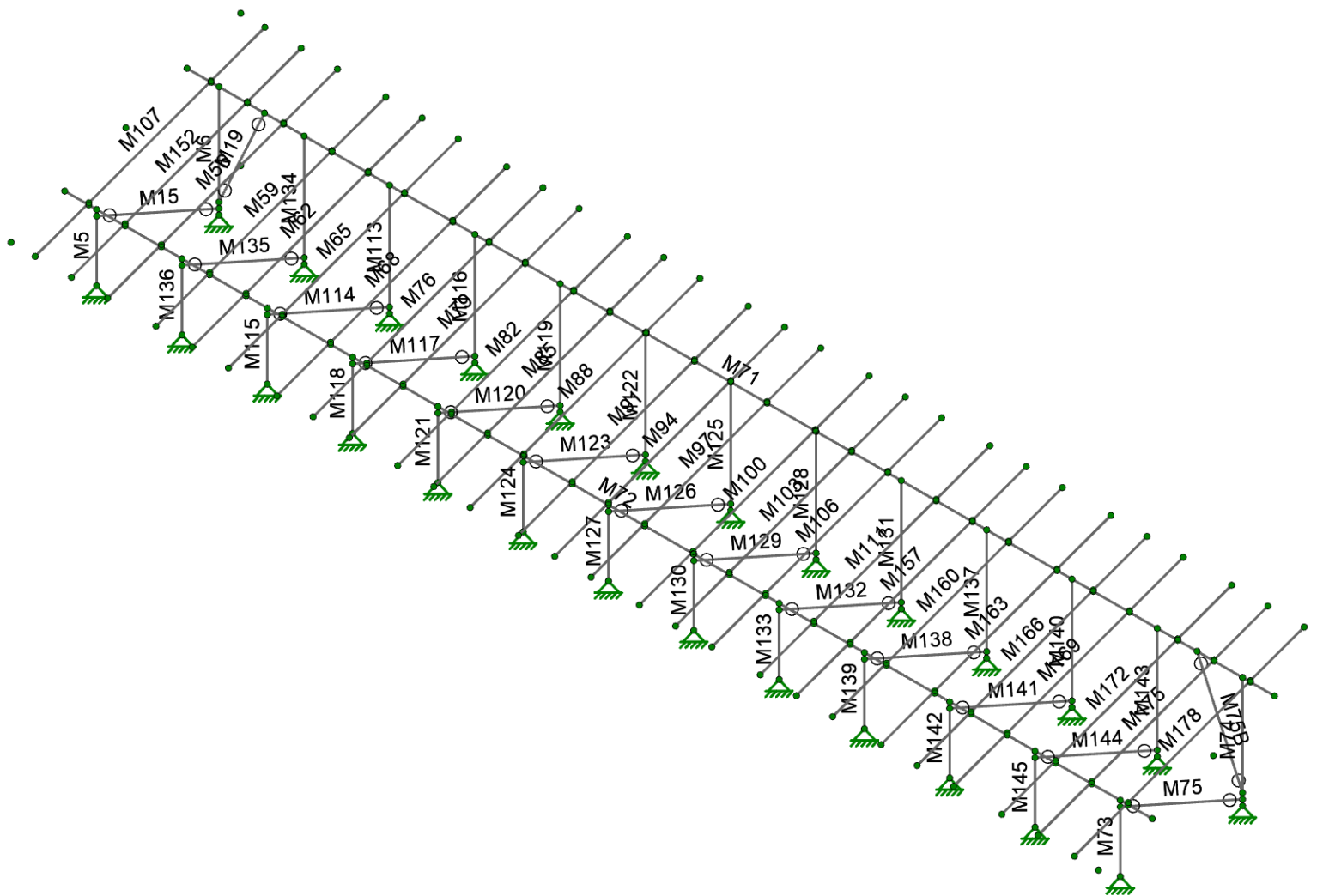
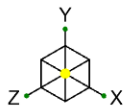

Vector Structural Engineering  
 CJT  
 U2716.0385.241

A16 Large Format Panels - 20 Degree Tilt

SK-2  
 Mar 20, 2024  
 Sunturf A16 - LF - 20deg.r3d

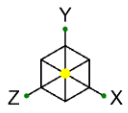

Section Sets

- █ Post
- █ Cross Beam
- █ Diagonal Brace
- █ RIGID
- █ AL Rails

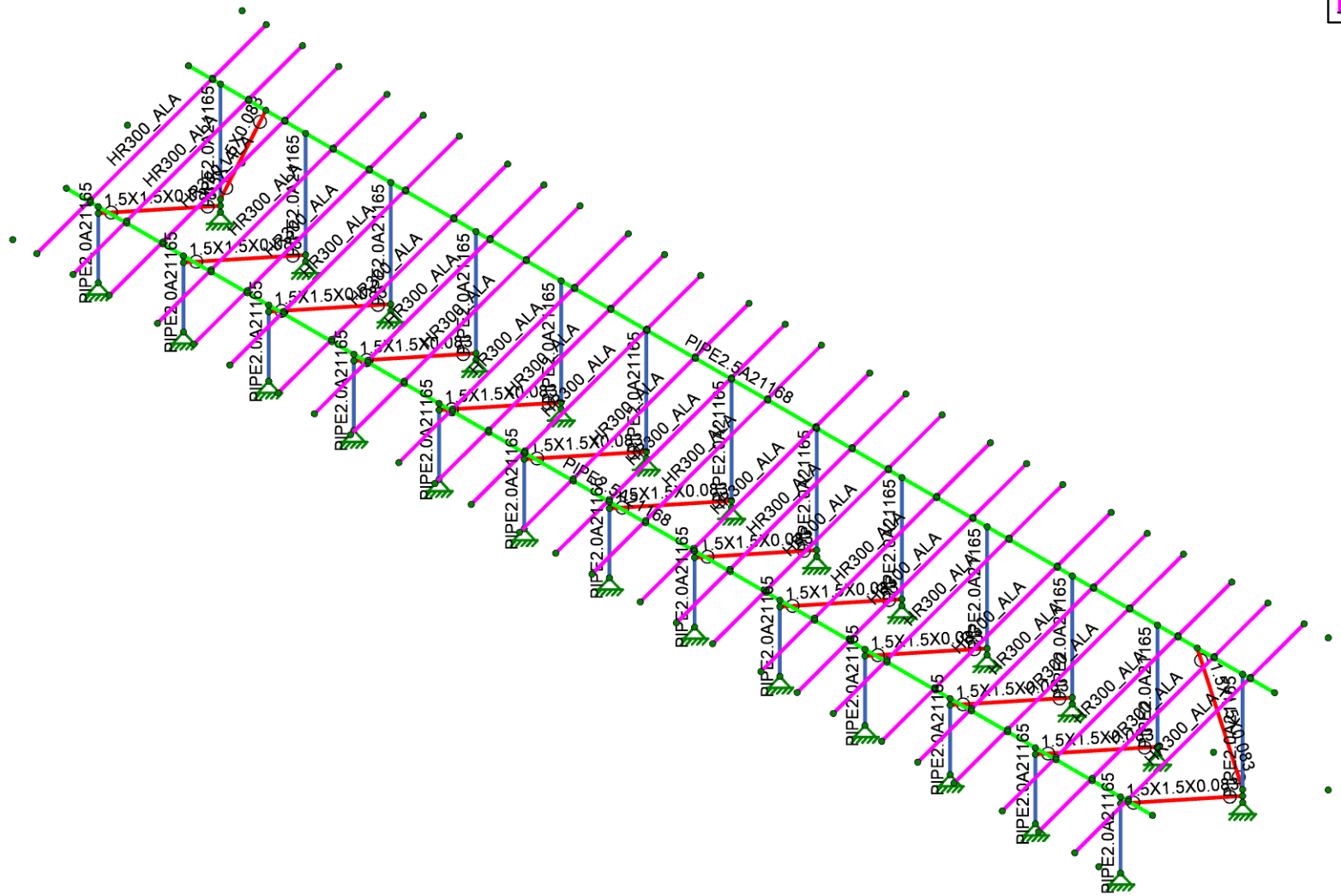

Vector Structural Engineering  
 CJT  
 U2716.0385.241

A16 Large Format Panels - 20 Degree Tilt

SK-3  
 Mar 20, 2024  
 Sunturf A16 - LF - 20deg.r3d

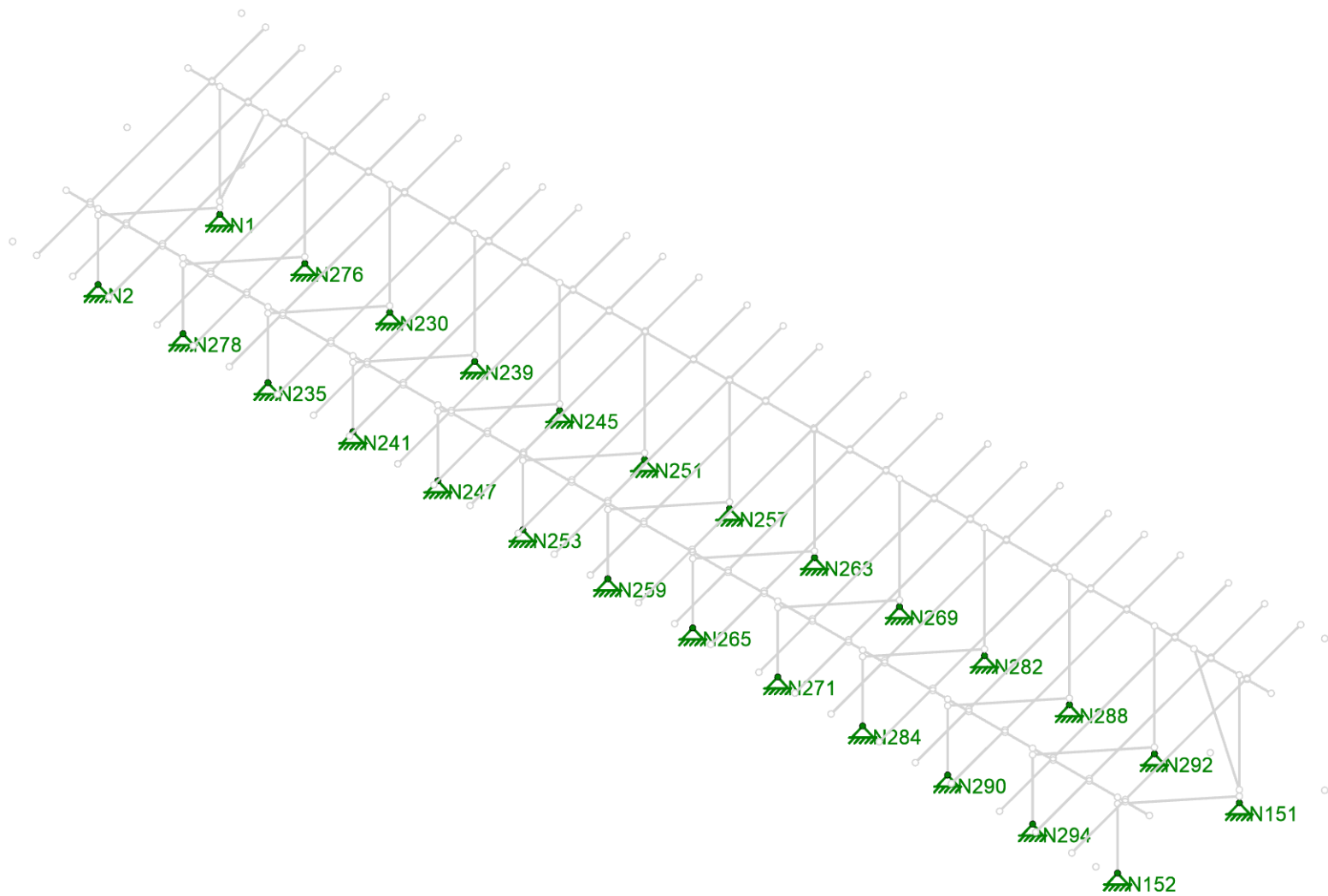
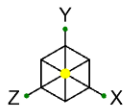

Vector Structural Engineering  
CJT  
U2716.0385.241

A16 Large Format Panels - 20 Degree Tilt

SK-4  
Mar 20, 2024  
Sunturf A16 - LF - 20deg.r3d

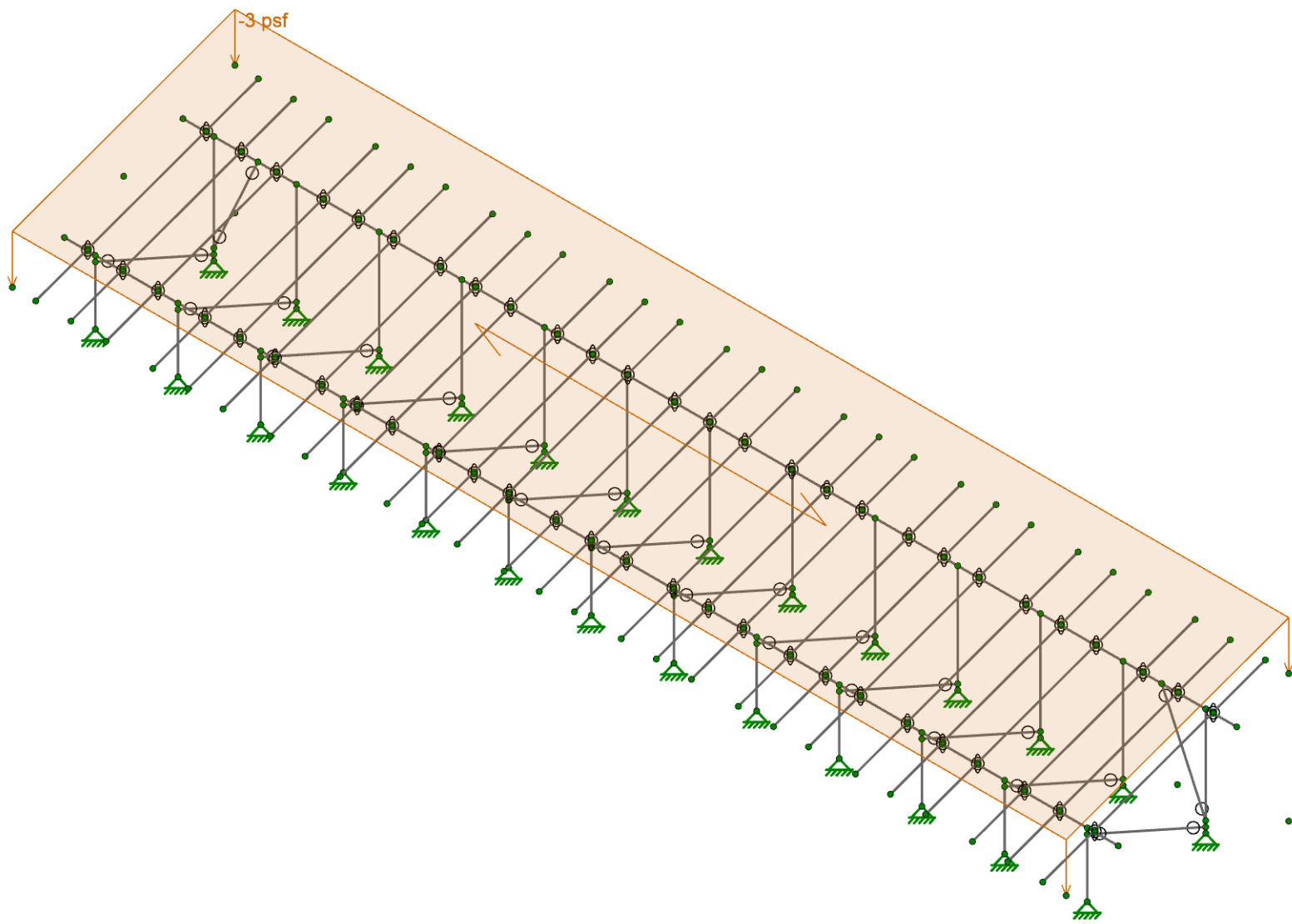
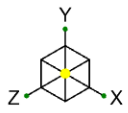

Loads: BLC 2, Solar Panel Weight

	Vector Structural Engineering
	CJT
	U2716.0385.241

A16 Large Format Panels - 20 Degree Tilt

SK-5
Mar 20, 2024
Sunturf A16 - LF - 20deg.r3d



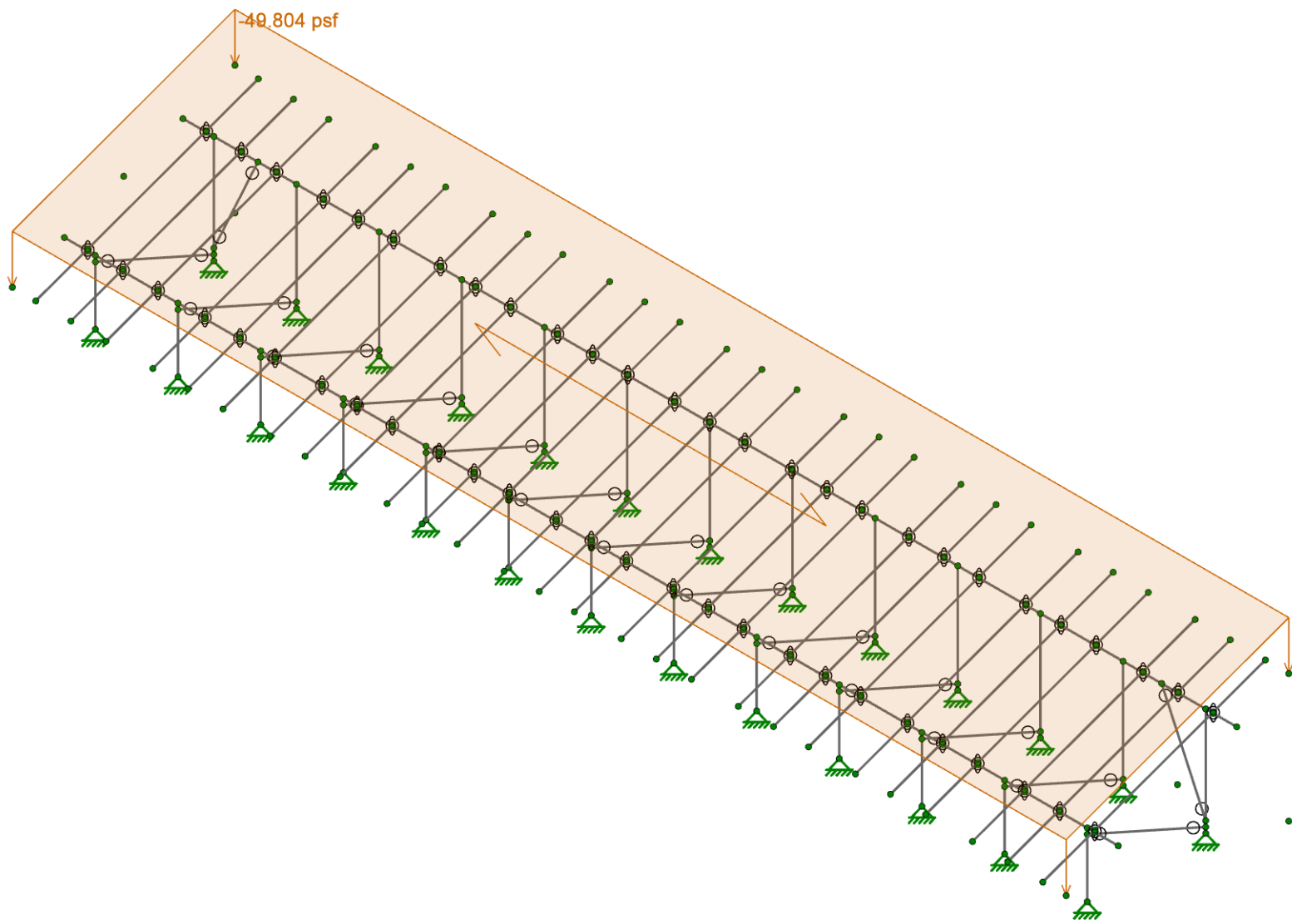
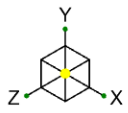

Loads: BLC 3, Roof Live/Snow

 IRISA A NEMETSCHEK COMPANY	Vector Structural Engineering
	CJT
	U2716.0385.241

A16 Large Format Panels - 20 Degree Tilt

SK-6
Mar 20, 2024
Sunturf A16 - LF - 20deg.r3d

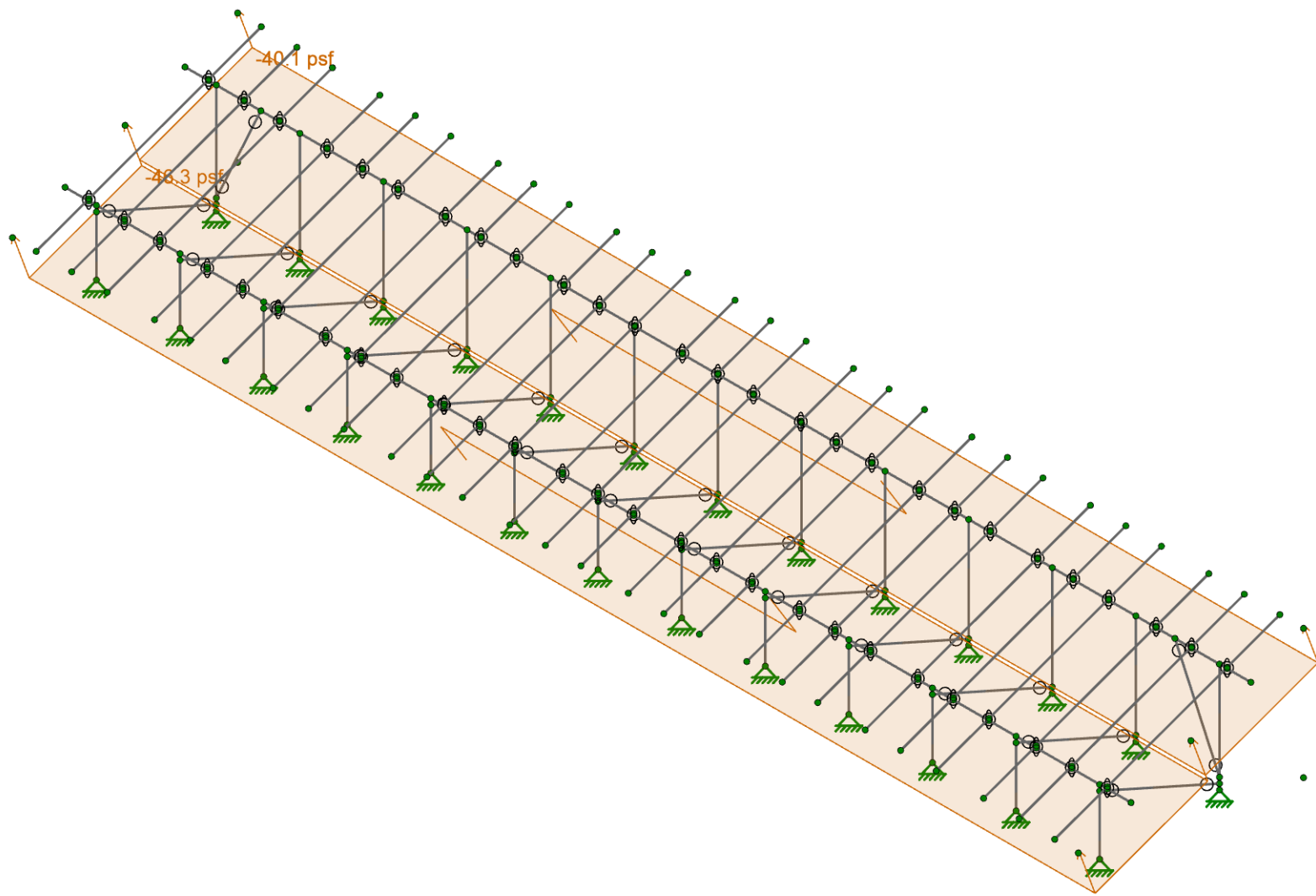
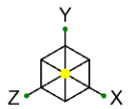

Loads: BLC 4, Wind A 0 deg



Vector Structural Engineering  
CJT  
U2716.0385.241

A16 Large Format Panels - 20 Degree Tilt

SK-7  
Mar 20, 2024  
Sunturf A16 - LF - 20deg.r3d

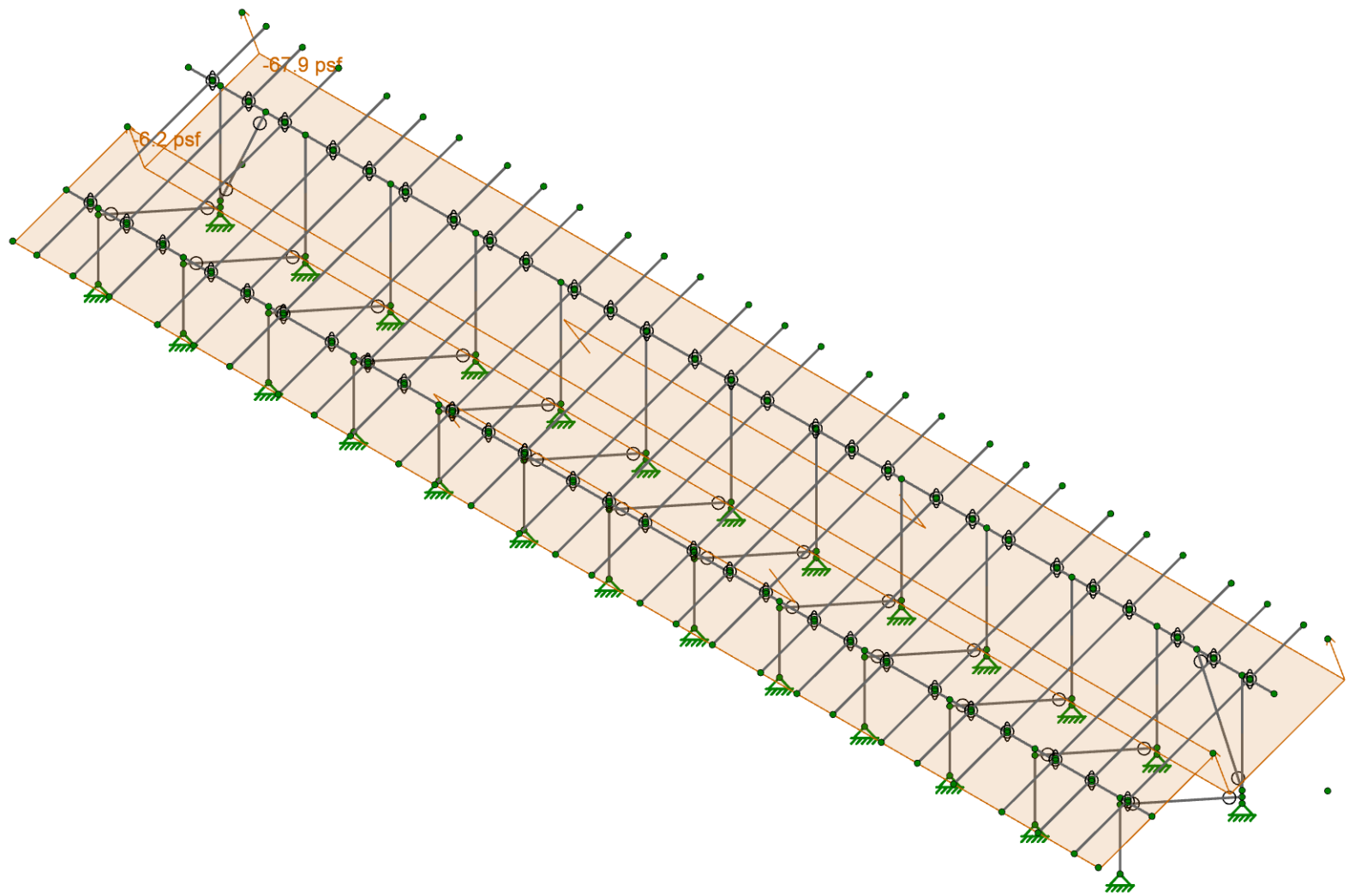
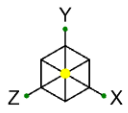

Loads: BLC 5, Wind B 0 deg



Vector Structural Engineering  
CJT  
U2716.0385.241

A16 Large Format Panels - 20 Degree Tilt

SK-8  
Mar 20, 2024  
Sunturf A16 - LF - 20deg.r3d

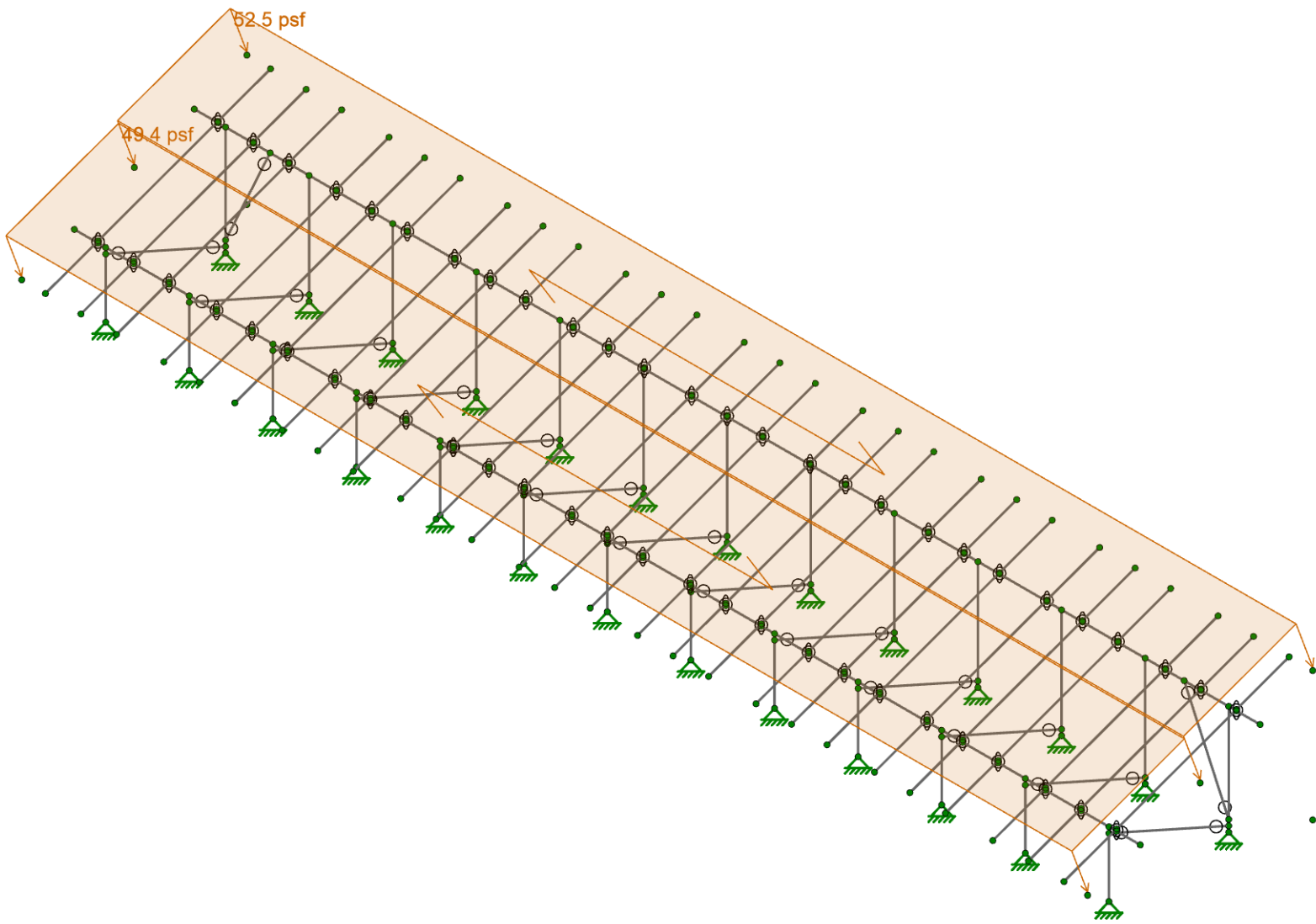
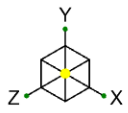

Loads: BLC 6, Wind A 180 deg



Vector Structural Engineering  
CJT  
U2716.0385.241

A16 Large Format Panels - 20 Degree Tilt

SK-9  
Mar 20, 2024  
Sunturf A16 - LF - 20deg.r3d

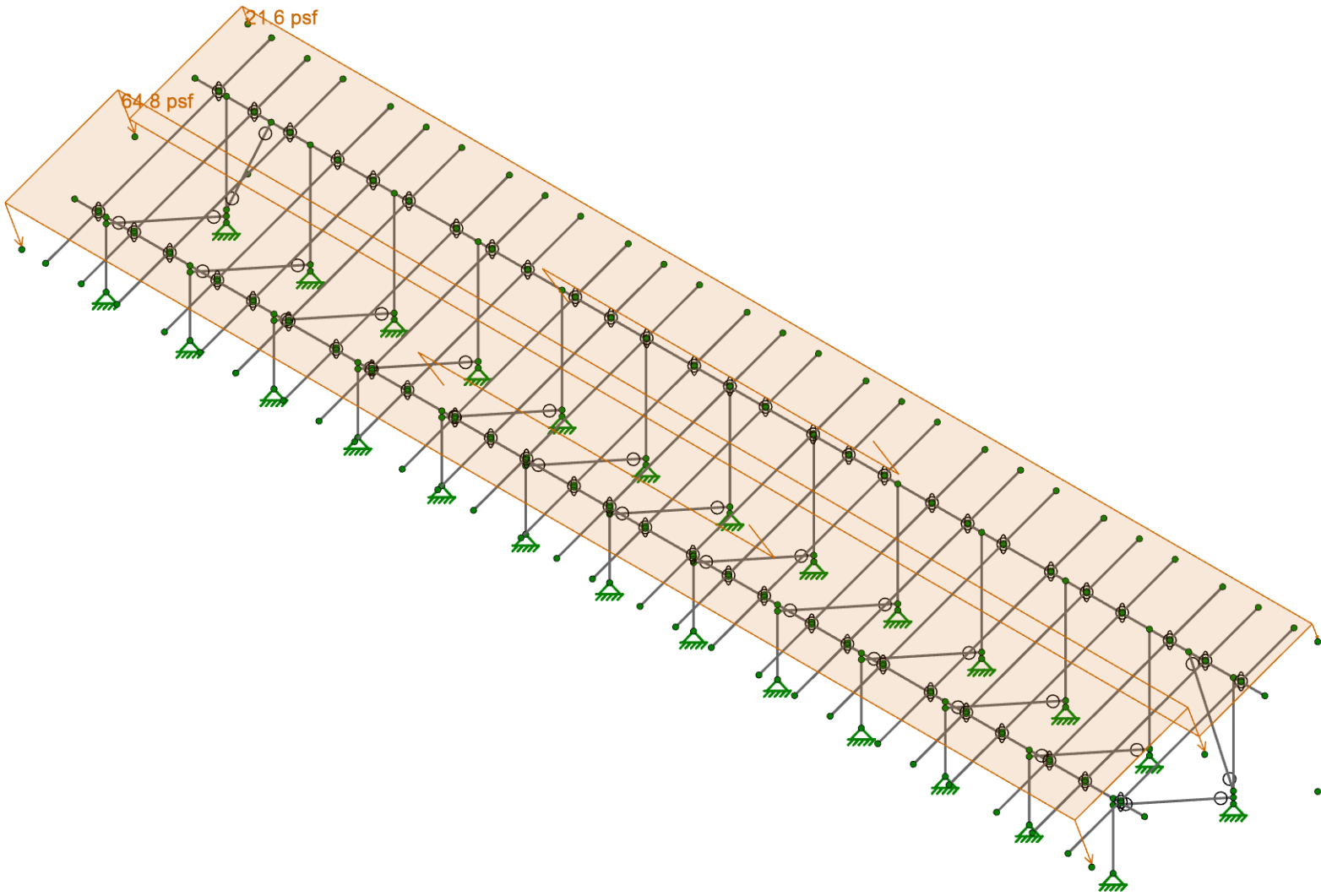
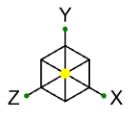

Loads: BLC 7, Wind B 180 deg

	Vector Structural Engineering
	CJT
	U2716.0385.241

A16 Large Format Panels - 20 Degree Tilt

SK-10
Mar 20, 2024
Sunturf A16 - LF - 20deg.r3d

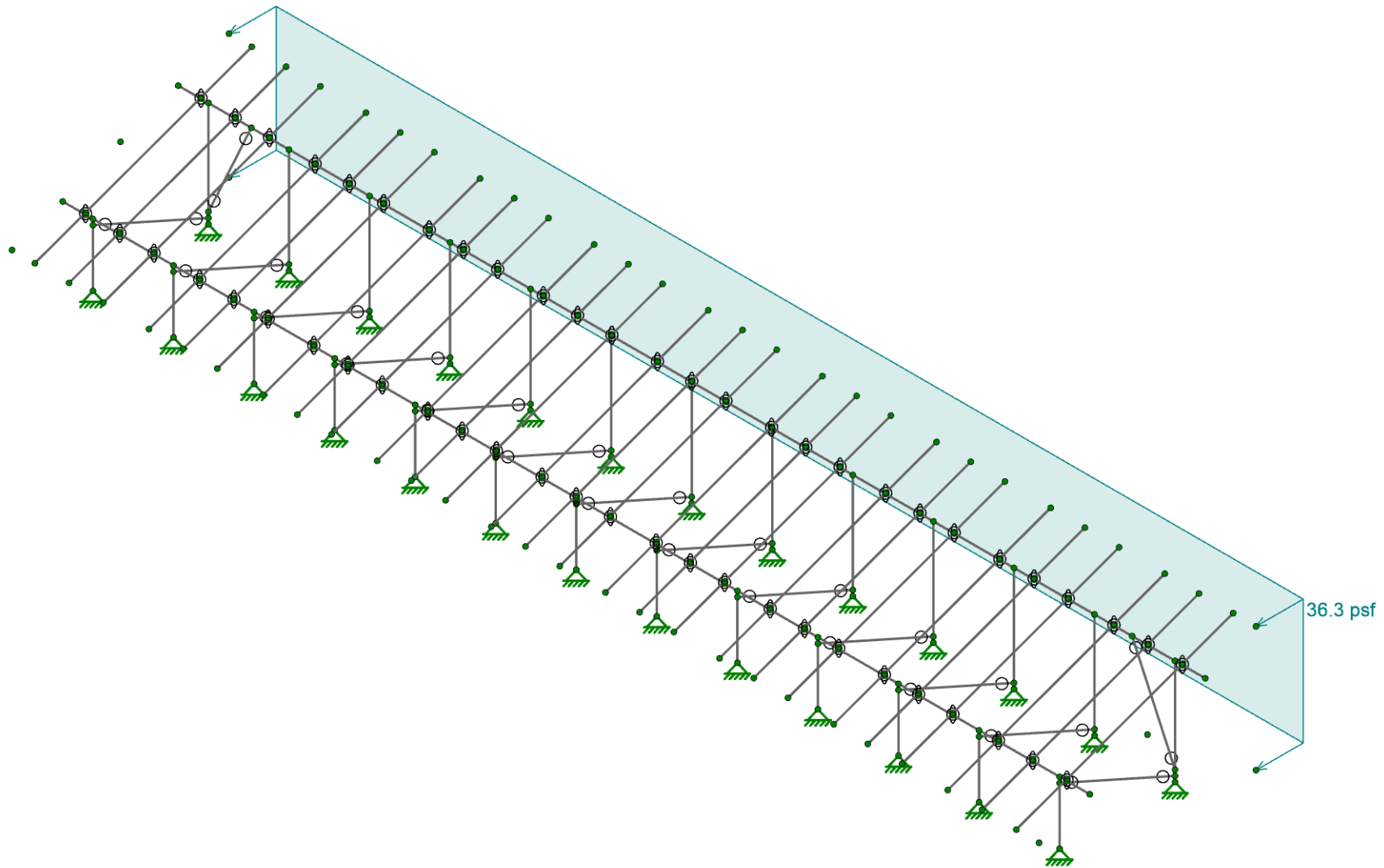
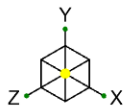

Loads: BLC 8, Wind Z



Vector Structural Engineering  
CJT  
U2716.0385.241

A16 Large Format Panels - 20 Degree Tilt

SK-11  
Mar 20, 2024  
Sunturf A16 - LF - 20deg.r3d

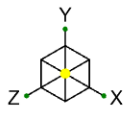

Code Check (Env)	
Black	No Calc
Red	> 1.0
Magenta	.90-1.0
Green	.75-.90
Cyan	.50-.75
Blue	0-.50

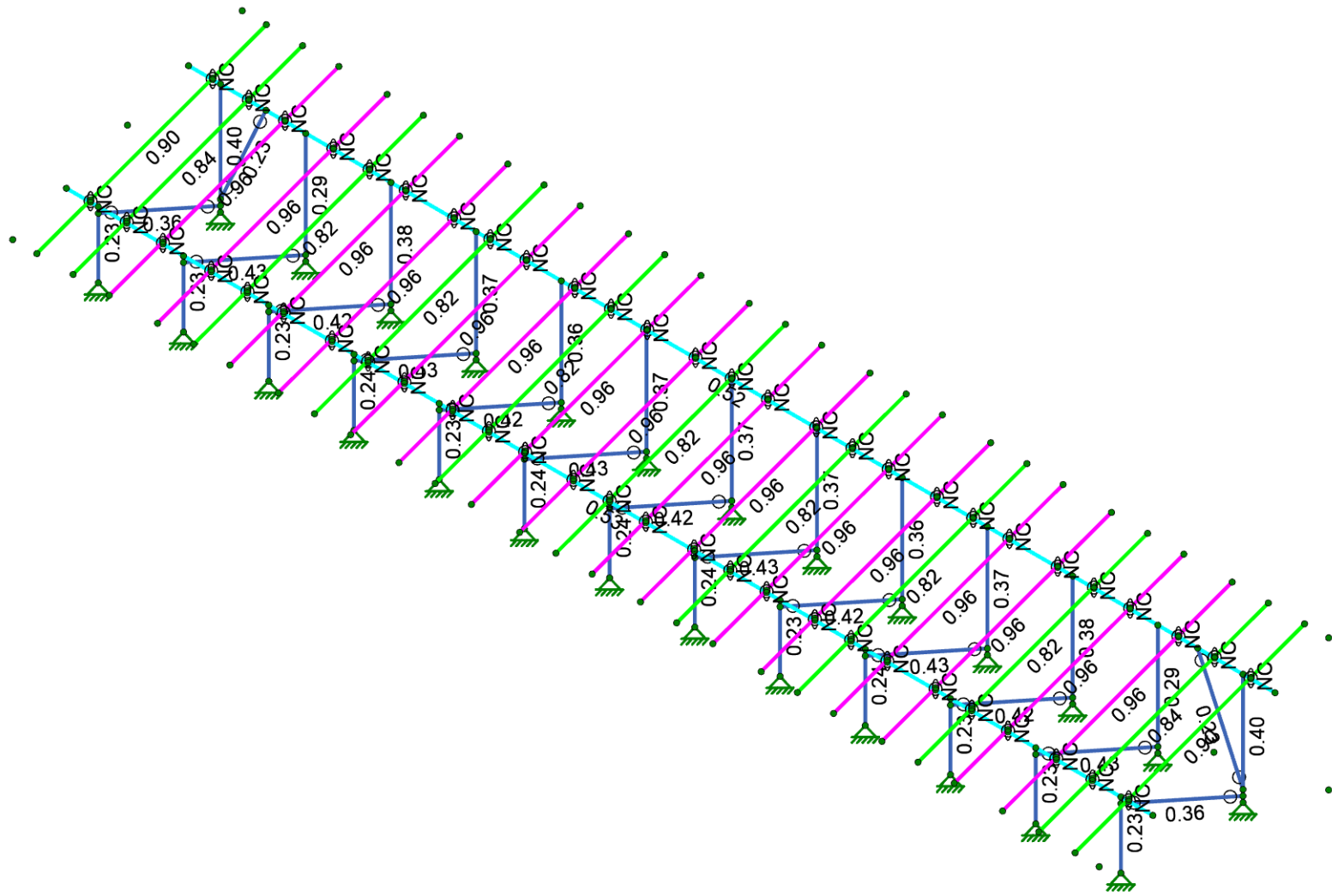

Member Code Checks Displayed (Enveloped)

	Vector Structural Engineering	A16 Large Format Panels - 20 Degree Tilt	SK-12
	CJT		Mar 20, 2024
	U2716.0385.241		Sunturf A16 - LF - 20deg.r3d

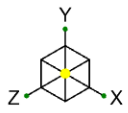

Shear Check (Env)

- No Calc
- > 1.0
- .90-1.0
- .75-90
- .50-75
- 0.-.50

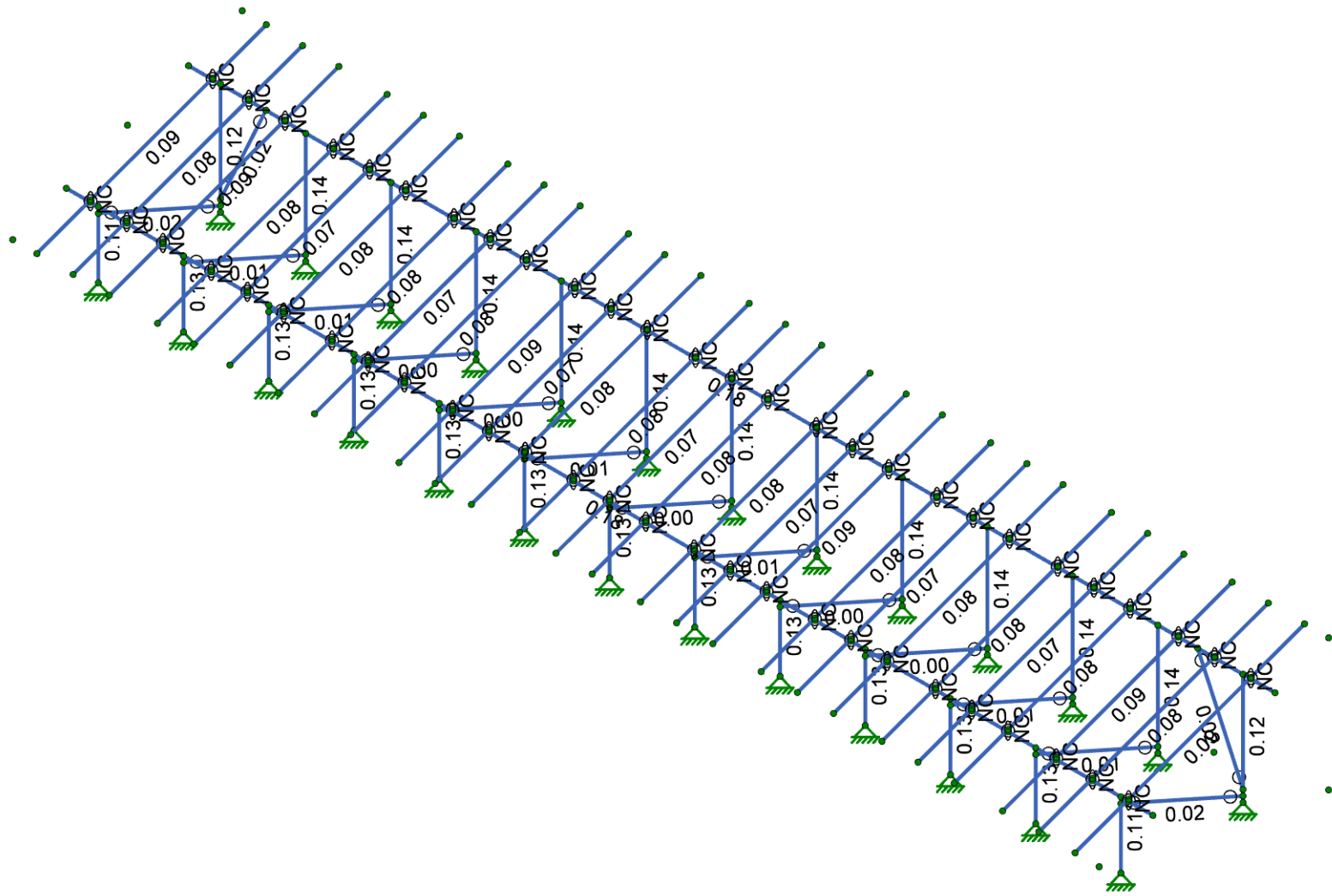

Member Shear Checks Displayed (Enveloped)

	Vector Structural Engineering	A16 Large Format Panels - 20 Degree Tilt	SK-13
	CJT		Mar 20, 2024
	U2716.0385.241		Sunturf A16 - LF - 20deg.r3d



**Model Settings**

Number of Reported Sections	5
Number of Internal Sections	100
Member Area Load Mesh Size (in <sup>2</sup> )	144
Consider Shear Deformation	Yes
Consider Torsional Warping	Yes
Approximate Mesh Size (in)	24
Transfer Forces Between Intersecting Wood Walls	Yes
Increase Wood Wall Nailing Capacity for Wind Loads	Yes
Include P-Delta for Walls	Yes
Optimize Masonry and Wood Walls	Yes
Maximum Number of Iterations	3
Single	No
Multiple (Optimum)	Yes
Maximum	No

Global Axis corresponding to vertical direction	Y
Convert Existing Data	Yes
Default Global Plane for z-axis	XZ
Plate Local Axis Orientation	Nodal

Hot Rolled Steel	AISC 15th (360-16): ASD
Stiffness Adjustment	Yes (Iterative)
Notional Annex	None
Connections	None
Cold Formed Steel	None
Stiffness Adjustment	Yes (Iterative)
Wood	None
Temperature	< 100F
Concrete	ACI 318-19
Masonry	None
Aluminum	AA ADM1-20: ASD
Structure Type	Building
Stiffness Adjustment	Yes (Iterative)
Stainless	None
Stiffness Adjustment	Yes (Iterative)

Compression Stress Block	Rectangular Stress Block
Analyze using Cracked Sections	No
Leave room for horizontal rebar splices (2*d bar spacing)	Yes
List forces which were ignored for design in the Detail Report	Yes

Column Min Steel	1
Column Max Steel	8
Rebar Material Spec	ASTM A615
Warn if beam-column framing arrangement is not understood	No
Number of Shear Regions	4
Region 2 & 3 Spacing Increase Increment (in)	3.999992



Company : Vector Structural Engineering  
Designer : CJT  
Job Number : U2716.0385.241  
Model Name : A16 Large Format Panels - 20 D...

3/20/2024  
3:17:04 PM  
Checked By : MIH

---

---

**Model Settings (Continued)**

T Z (sec)	
T X (sec)	
C <sub>Z</sub>	0.02
C <sub>X</sub>	0.02
R Z	3
R X	3

**Hot Rolled Steel Properties**

	Label	E [ksi]	G [ksi]	Nu	Therm. Coeff. [1e <sup>5</sup> F <sup>-1</sup> ]	Density [lb/ft <sup>3</sup> ]	Yield [psi]	Ry	Fu [psi]	Rt
1	A992	29000	11154	0.3	0.65	490	50000	1.1	65000	1.1
2	A36 Gr.36	29000	11154	0.3	0.65	490	36000	1.5	58000	1.2
3	A572 Gr.50	29000	11154	0.3	0.65	490	50000	1.1	65000	1.1
4	A500 Gr.B RND	29000	11154	0.3	0.65	527	42000	1.4	58000	1.3
5	A500 Gr.B Rect	29000	11154	0.3	0.65	527	46000	1.4	58000	1.3
6	A53 Gr.B	29000	11154	0.3	0.65	490	35000	1.6	60000	1.2
7	A1085	29000	11154	0.3	0.65	490	50000	1.4	65000	1.3

**Aluminum Properties**

	Label	E [ksi]	G [ksi]	Nu	Therm. Coeff. [1e <sup>5</sup> F <sup>-1</sup> ]	Density [lb/ft <sup>3</sup> ]	Table B.4	kt	Ftu [psi]	Fty [psi]	Fcy [psi]	Fsu [psi]	Ct
1	3003-H14	10100	3787.5	0.33	1.3	172.8	Table B.4-1	1	19000	16000	13000	12000	141
2	6061-T6	10100	3787.5	0.33	1.3	172.8	Table B.4-2	1	38000	35000	35000	24000	141
3	6063-T5	10100	3787.5	0.33	1.3	172.8	Table B.4-2	1	22000	16000	16000	13000	141
4	6063-T6	10100	3787.5	0.33	1.3	172.8	Table B.4-2	1	30000	25000	25000	19000	141
5	5052-H34	10200	3787.5	0.33	1.3	172.8	Table B.4-1	1	34000	26000	24000	20000	141
6	6061-T6 W	10100	3787.5	0.33	1.3	172.8	Table B.4-1	1	24000	15000	15000	15000	141
7	6005-T5	10100	3787.5	0.33	1.3	172.8	Table B.4-1	1	38000	35000	35000	24000	141

**Hot Rolled Steel Section Sets**

	Label	Shape	Type	Design List	Material	Design Rule	Area [in <sup>2</sup> ]	Iyy [in <sup>4</sup> ]	Izz [in <sup>4</sup> ]	J [in <sup>4</sup> ]
1	Post	PIPE2.0A21165	Column	Pipe	A572 Gr.50	Typical	0.776	0.499	0.499	0.998
2	Cross Beam	PIPE2.5A21168	Beam	Wide Flange	A572 Gr.50	Typical	0.947	0.907	0.907	1.814
3	Diagonal Brace	1.5X1.5X0.083	HBrace	SquareTube	A572 Gr.50	Typical	0.47	0.158	0.158	0.236

**Aluminum Section Sets**

	Label	Shape	Type	Design List	Material	Design Rule	Area [in <sup>2</sup> ]	Iyy [in <sup>4</sup> ]	Izz [in <sup>4</sup> ]	J [in <sup>4</sup> ]
1	AL Posts	2.375ODX0.188	Column	Pipe	6005-T5	Typical	1.29	0.778	0.778	1.54
2	AL Brace	RT1.5X2X0.15625	VBrace	Rectangular Tubes	6005-T5	Typical	0.996	0.327	0.524	0.602
3	AL Rails	HR300 ALA	Beam	Rectangular Tubes	6005-T5	Typical	0.736	0.214	0.727	0.734
4	AL Cross Beam	CROSSRAIL	Beam	Rectangular Tubes	6005-T5	Typical	1.909	1.97	4.366	4.017

**Basic Load Cases**

	BLC Description	Category	Y Gravity	Distributed	Area(Member)
1	Self Weight	DL	-1.05		
2	Solar Panel Weight	DL			1
3	Roof Live/Snow	RLL			1
4	Wind A 0 deg	OL1			2
5	Wind B 0 deg	OL2			2
6	Wind A 180 deg	OL3			2
7	Wind B 180 deg	OL4			2
8	Wind Z	WLZ			1
9	BLC 2 Transient Area Loads	None		51	
10	BLC 3 Transient Area Loads	None		51	
11	BLC 4 Transient Area Loads	None		172	
12	BLC 5 Transient Area Loads	None		172	
13	BLC 6 Transient Area Loads	None		172	
14	BLC 7 Transient Area Loads	None		172	
15	BLC 8 Transient Area Loads	None		109	

**Member Area Loads (BLC 2 : Solar Panel Weight)**

	Node A	Node B	Node C	Node D	Direction	Load	Direction	A Magnitude [psf]	B Magnitude [psf]	C Magnitude [psf]	D Magnitude [psf]	Exclude Braces
1	N197	N200	N199	N196	Y		A-B	-3	-3	-3	-3	Yes

**Member Area Loads (BLC 3 : Roof Live/Snow)**

	Node A	Node B	Node C	Node D	Direction	Load	Direction	A Magnitude [psf]	B Magnitude [psf]	C Magnitude [psf]	D Magnitude [psf]	Exclude Braces
1	N197	N200	N199	N196	PY		A-B	-53	-53	-53	-53	Yes

**Member Area Loads (BLC 4 : Wind A 0 deg)**

	Node A	Node B	Node C	Node D	Direction	Load	Direction	A Magnitude [psf]	B Magnitude [psf]	C Magnitude [psf]	D Magnitude [psf]	Exclude Braces
1	N197	N200	N201	N198	Perp		A-B	-40.1	-40.1	-40.1	-40.1	Yes
2	N198	N201	N199	N196	Perp		A-B	-46.3	-46.3	-46.3	-46.3	Yes

**Member Area Loads (BLC 5 : Wind B 0 deg)**

	Node A	Node B	Node C	Node D	Direction	Load	Direction	A Magnitude [psf]	B Magnitude [psf]	C Magnitude [psf]	D Magnitude [psf]	Exclude Braces
1	N197	N200	N201	N198	Perp		A-B	-67.9	-67.9	-67.9	-67.9	Yes
2	N198	N201	N199	N196	Perp		A-B	-6.2	-6.2	-6.2	-6.2	Yes

**Member Area Loads (BLC 6 : Wind A 180 deg)**

	Node A	Node B	Node C	Node D	Direction	Load	Direction	A Magnitude [psf]	B Magnitude [psf]	C Magnitude [psf]	D Magnitude [psf]	Exclude Braces
1	N197	N200	N201	N198	Perp		A-B	52.5	52.5	52.5	52.5	Yes
2	N198	N201	N199	N196	Perp		A-B	49.4	49.4	49.4	49.4	Yes

**Member Area Loads (BLC 7 : Wind B 180 deg)**

	Node A	Node B	Node C	Node D	Direction	Load	Direction	A Magnitude [psf]	B Magnitude [psf]	C Magnitude [psf]	D Magnitude [psf]	Exclude Braces
1	N197	N200	N201	N198	Perp		A-B	21.6	21.6	21.6	21.6	Yes
2	N198	N201	N199	N196	Perp		A-B	64.8	64.8	64.8	64.8	Yes

**Member Area Loads (BLC 8 : Wind Z)**

	Node A	Node B	Node C	Node D	Direction	Load	Direction	A Magnitude [psf]	B Magnitude [psf]	C Magnitude [psf]	D Magnitude [psf]	Exclude Braces
1	N200	N197	N307	N308	Z		Open Structure	36.3	36.3	36.3	36.3	Yes

**Load Combinations**

	Description	Solve	P-Delta	BLC	Factor	BLC	Factor	BLC	Factor	BLC	Factor
1	ASD Loads		Y								
2	1.0 D	Yes	Y	DL	1						
3	1.0 D + 1.0 S	Yes	Y	DL	1	RLL	1				
4	1.0 D + 0.6 W1	Yes	Y	DL	1	RLL		OL1	0.6	WLZ	0.6
5	1.0 D + 0.6 W2	Yes	Y	DL	1	RLL		OL2	0.6	WLZ	0.6
6	1.0 D + 0.6 W3	Yes	Y	DL	1	RLL		OL3	0.6	WLZ	-0.6
7	1.0 D + 0.6 W4	Yes	Y	DL	1	RLL		OL4	0.6	WLZ	-0.6
8	1.0 D + 0.45 W1 + 0.75 S	Yes	Y	DL	1	RLL	0.75	OL1	0.45	WLZ	0.45
9	1.0 D + 0.45 W2 + 0.75 S	Yes	Y	DL	1	RLL	0.75	OL2	0.45	WLZ	0.45
10	1.0 D + 0.45 W3 + 0.75 S	Yes	Y	DL	1	RLL	0.75	OL3	0.45	WLZ	-0.45
11	1.0 D + 0.45 W4 + 0.75 S	Yes	Y	DL	1	RLL	0.75	OL4	0.45	WLZ	-0.45
12	0.6 D + 0.6 W1	Yes	Y	DL	0.6	RLL		OL1	0.6	WLZ	0.6
13	0.6 D + 0.6 W2	Yes	Y	DL	0.6	RLL		OL2	0.6	WLZ	0.6

**Load Combinations (Continued)**

	Description	Solve	P-Delta	BLC	Factor	BLC	Factor	BLC	Factor	BLC	Factor
14	0.6 D + 0.6 W3	Yes	Y	DL	0.6	RLL		OL3	0.6	WLZ	-0.6
15	0.6 D + 0.6 W4	Yes	Y	DL	0.6	RLL		OL4	0.6	WLZ	-0.6
16			Y								
17	LRFD Loads		Y								
18	1.4 D		Y	DL	1.4	RLL					
19	1.2 D + 1.6 S + 0.5 W1		Y	DL	1.2	RLL	1.6	OL1	0.5		
20	1.2 D + 1.6 S + 0.5 W2		Y	DL	1.2	RLL	1.6	OL2	0.5		
21	1.2 D + 1.6 S + 0.5 W3		Y	DL	1.2	RLL	1.6	OL3	0.5		
22	1.2 D + 1.6 S + 0.5 W4		Y	DL	1.2	RLL	1.6	OL4	0.5		
23	1.2 D + 1.0 W1		Y	DL	1.2	RLL		OL1	1		
24	1.2 D + 1.0 W2		Y	DL	1.2	RLL		OL2	1		
25	1.2 D + 1.0 W3		Y	DL	1.2	RLL		OL3	1		
26	1.2 D + 1.0 W4		Y	DL	1.2	RLL		OL4	1		
27	0.9 D + 1.0 W1		Y	DL	0.9	RLL		OL1	1		
28	0.9 D + 1.0 W2		Y	DL	0.9	RLL		OL2	1		
29	0.9 D + 1.0 W3		Y	DL	0.9	RLL		OL3	1		
30	0.9 D + 1.0 W4		Y	DL	0.9	RLL		OL4	1		

**Envelope Node Reactions**

	Node Label	X [lb]	LC	Y [lb]	LC	Z [lb]	LC	MX [lb-ft]	LC	MY [lb-ft]	LC	MZ [lb-ft]	LC	
1	N2	max	44.03	11	1783.226	11	57.016	4	0	15	0	15	0	15
2		min	-15.177	12	-257.137	12	-69.706	6	0	2	0	2	0	2
3	N1	max	320.175	10	2832.84	10	813.905	6	0	15	0	15	0	15
4		min	-188.258	13	-1797.802	13	-705.705	4	0	2	0	2	0	2
5	N151	max	188.258	13	2832.84	10	813.915	6	0	15	0	15	0	15
6		min	-320.175	10	-1797.809	13	-705.713	4	0	2	0	2	0	2
7	N152	max	15.177	12	1783.221	11	57.016	4	0	15	0	15	0	15
8		min	-44.029	11	-257.128	12	-69.707	6	0	2	0	2	0	2
9	N276	max	10.435	10	2317.203	10	970.404	6	0	15	0	15	0	15
10		min	-6.174	13	-1508.391	13	-837.872	12	0	2	0	2	0	2
11	N278	max	3.345	12	2122.267	11	62.646	4	0	15	0	15	0	15
12		min	-10.888	11	-314.485	12	-77.141	6	0	2	0	2	0	2
13	N230	max	3.638	13	2864.816	10	956.761	14	0	15	0	15	0	15
14		min	-5.959	10	-1847.893	13	-828.367	4	0	2	0	2	0	2
15	N235	max	2.656	12	2083.591	11	64.082	4	0	15	0	15	0	15
16		min	-7.457	11	-298.497	12	-78.639	6	0	2	0	2	0	2
17	N239	max	4.221	10	2784.735	10	958.585	6	0	15	0	15	0	15
18		min	-2.456	13	-1796.349	13	-828.362	4	0	2	0	2	0	2
19	N241	max	8.454	11	2104.634	11	64.212	4	0	15	0	15	0	15
20		min	-2.349	12	-308.64	12	-78.906	6	0	2	0	2	0	2
21	N245	max	4.948	10	2750.578	10	936.661	6	0	15	0	15	0	15
22		min	-2.954	13	-1763.055	13	-810.826	4	0	2	0	2	0	2
23	N247	max	11.549	11	2058.514	11	63.571	4	0	15	0	15	0	15
24		min	-3.14	12	-304.901	12	-78.068	6	0	2	0	2	0	2
25	N251	max	2.815	13	2783.111	10	961.93	6	0	15	0	15	0	15
26		min	-4.925	10	-1796.929	13	-831.385	4	0	2	0	2	0	2
27	N253	max	4.236	12	2073.977	11	64.403	4	0	15	0	15	0	15
28		min	-12.373	11	-296.024	12	-79.037	6	0	2	0	2	0	2
29	N257	max	0	15	2789.315	10	946.717	6	0	15	0	15	0	15
30		min	0	8	-1793.93	13	-819.263	4	0	2	0	2	0	2
31	N259	max	0	12	2107.719	11	64.085	4	0	15	0	15	0	15
32		min	0	11	-315.567	12	-78.705	6	0	2	0	2	0	2
33	N263	max	4.925	10	2783.111	10	961.926	6	0	15	0	15	0	15
34		min	-2.815	13	-1796.927	13	-831.382	4	0	2	0	2	0	2
35	N265	max	12.373	11	2073.976	11	64.403	4	0	15	0	15	0	15



**Envelope Node Reactions (Continued)**

Node Label	X [lb]	LC	Y [lb]	LC	Z [lb]	LC	MX [lb-ft]	LC	MY [lb-ft]	LC	MZ [lb-ft]	LC		
36	min	-4.236	12	-296.026	12	-79.037	6	0	2	0	2	0	2	
37	N269	max	2.954	13	2750.578	10	936.661	6	0	15	0	15	0	15
38	min	-4.947	10	-1763.054	13	-810.825	4	0	2	0	2	0	2	
39	N271	max	3.14	12	2058.511	11	63.571	4	0	15	0	15	0	15
40	min	-11.55	11	-304.9	12	-78.068	6	0	2	0	2	0	2	
41	N282	max	2.456	13	2784.741	10	958.591	6	0	15	0	15	0	15
42	min	-4.221	10	-1796.355	13	-828.367	4	0	2	0	2	0	2	
43	N284	max	2.349	12	2104.63	11	64.212	4	0	15	0	15	0	15
44	min	-8.454	11	-308.635	12	-78.907	6	0	2	0	2	0	2	
45	N288	max	5.959	10	2864.833	10	956.748	14	0	15	0	15	0	15
46	min	-3.638	13	-1847.897	13	-828.356	4	0	2	0	2	0	2	
47	N290	max	7.457	11	2083.595	11	64.082	4	0	15	0	15	0	15
48	min	-2.656	12	-298.506	12	-78.639	6	0	2	0	2	0	2	
49	N292	max	6.174	13	2317.235	10	970.411	6	0	15	0	15	0	15
50	min	-10.436	10	-1508.411	13	-837.877	12	0	2	0	2	0	2	
51	N294	max	10.887	11	2122.258	11	62.647	4	0	15	0	15	0	15
52	min	-3.345	12	-314.48	12	-77.142	6	0	2	0	2	0	2	
53	Totals:	max	0.001	12	57916.824	10	11141.489	14						
54	min	-0.002	11	-19796.614	12	-9688.268	4							

**Envelope AISC 15TH (360-16): ASD Member Steel Code Checks**

Member	Shape	Code Check	Loc[in]	LC	Shear Check	Loc[in]	Dir	LC	Pnc/om [lb]	Pnt/om [lb]	Mnyy/om [lb-ft]	Mnzz/om [lb-ft]	Cb	Eqn	
1	M5	PIPE2.0A21165	0.227	42.549	10	0.112	42.549	6	18186.27	23232.186	1397.505	1397.505	1	H1-1b	
2	M6	PIPE2.0A21165	0.403	7.333	10	0.124	0	6	11590.083	23232.186	1397.505	1397.505	1	H1-1a	
3	M15	1.5X1.5X0.083	0.362	48.077	6	0.024	94.191	y	10	2676.371	14085.15	624.421	624.421	1.136	H1-1a
4	M19	1.5X1.5X0.083	0.232	43.407	10	0.02	77.168	y	6	3987.368	14085.15	624.421	624.421	1.136	H1-1a
5	M73	PIPE2.0A21165	0.227	42.549	10	0.112	42.549	6	18186.27	23232.186	1397.505	1397.505	1	H1-1b	
6	M74	PIPE2.0A21165	0.403	7.333	10	0.124	0	6	11590.083	23232.186	1397.505	1397.505	1	H1-1a	
7	M75	1.5X1.5X0.083	0.362	48.076	6	0.024	94.191	y	10	2676.388	14085.15	624.421	624.421	1.136	H1-1a
8	M75B	1.5X1.5X0.083	0.232	43.407	10	0.02	77.168	y	6	3987.368	14085.15	624.421	624.421	1.136	H1-1a
9	M71	PIPE2.5A21168	0.524	502.031	10	0.183	262.969	10	20336.2	28358.413	2081.747	2081.747	1	H1-1b	
10	M72	PIPE2.5A21168	0.525	262.969	11	0.177	502.031	11	20336.2	28358.413	2081.747	2081.747	1	H1-1b	
11	M134	PIPE2.0A21165	0.287	4.074	6	0.143	0	6	11590.083	23232.186	1397.505	1397.505	1	H1-1b	
12	M135	1.5X1.5X0.083	0.43	48.076	6	0.005	94.191	y	10	2676.388	14085.15	624.421	624.421	1.136	H1-1a
13	M136	PIPE2.0A21165	0.231	42.549	6	0.133	42.549	6	18186.27	23232.186	1397.505	1397.505	1	H1-1b	
14	M113	PIPE2.0A21165	0.377	4.074	10	0.142	0	6	11590.083	23232.186	1397.505	1397.505	1	H1-1a	
15	M114	1.5X1.5X0.083	0.424	48.076	6	0.006	94.191	y	10	2676.388	14085.15	624.421	624.421	1.136	H1-1a
16	M115	PIPE2.0A21165	0.235	42.549	6	0.131	42.549	6	18186.27	23232.186	1397.505	1397.505	1	H1-1b	
17	M116	PIPE2.0A21165	0.371	3.259	10	0.142	0	6	11590.083	23232.186	1397.505	1397.505	1	H1-1a	
18	M117	1.5X1.5X0.083	0.425	48.076	6	0.004	94.191	y	10	2676.388	14085.15	624.421	624.421	1.136	H1-1a
19	M118	PIPE2.0A21165	0.236	42.549	6	0.131	42.549	6	18186.27	23232.186	1397.505	1397.505	1	H1-1b	
20	M119	PIPE2.0A21165	0.365	3.259	10	0.139	0	6	11590.083	23232.186	1397.505	1397.505	1	H1-1a	
21	M120	1.5X1.5X0.083	0.415	48.076	6	0.005	94.191	y	3	2676.388	14085.15	624.421	624.421	1.136	H1-1a
22	M121	PIPE2.0A21165	0.233	42.549	6	0.128	42.549	6	18186.27	23232.186	1397.505	1397.505	1	H1-1b	
23	M122	PIPE2.0A21165	0.371	3.259	10	0.142	0	6	11590.083	23232.186	1397.505	1397.505	1	H1-1a	
24	M123	1.5X1.5X0.083	0.427	48.076	6	0.006	94.191	y	10	2676.388	14085.15	624.421	624.421	1.136	H1-1a
25	M124	PIPE2.0A21165	0.236	42.549	6	0.132	42.549	6	18186.27	23232.186	1397.505	1397.505	1	H1-1b	
26	M125	PIPE2.0A21165	0.369	3.259	10	0.14	0	6	11590.083	23232.186	1397.505	1397.505	1	H1-1a	
27	M126	1.5X1.5X0.083	0.42	48.076	6	0.002	94.191	y	8	2676.388	14085.15	624.421	624.421	1.136	H1-1a
28	M127	PIPE2.0A21165	0.235	42.549	6	0.129	42.549	6	18186.27	23232.186	1397.505	1397.505	1	H1-1b	
29	M128	PIPE2.0A21165	0.371	3.259	10	0.142	0	6	11590.083	23232.186	1397.505	1397.505	1	H1-1a	
30	M129	1.5X1.5X0.083	0.427	48.076	6	0.006	94.191	y	10	2676.388	14085.15	624.421	624.421	1.136	H1-1a
31	M130	PIPE2.0A21165	0.236	42.549	6	0.132	42.549	6	18186.27	23232.186	1397.505	1397.505	1	H1-1b	
32	M131	PIPE2.0A21165	0.365	3.259	10	0.139	0	6	11590.083	23232.186	1397.505	1397.505	1	H1-1a	
33	M132	1.5X1.5X0.083	0.415	48.076	6	0.005	94.191	y	3	2676.388	14085.15	624.421	624.421	1.136	H1-1a

**Envelope AISC 15TH (360-16): ASD Member Steel Code Checks (Continued)**

Member	Shape	Code Check	Loc[in]	LcShear	Check	Loc[in]	DirLcPnc/om	[lb]	Pnt/om	[lb]	Mnyy/om	[lb-ft]	Mnzz/om	[lb-ft]	Cb	Eqn
34	M133	PIPE2.0A21165	0.233	42.549	6	0.128	42.549	6	18186.27	23232.186	1397.505	1397.505	1	1	H1-1b	
35	M137	PIPE2.0A21165	0.371	3.259	10	0.142	0	6	11590.083	23232.186	1397.505	1397.505	1	1	H1-1a	
36	M138	1.5X1.5X0.083	0.425	48.076	6	0.004	94.191	y	10	2676.388	14085.15	624.421	624.421	1.136	1	H1-1a
37	M139	PIPE2.0A21165	0.236	42.549	6	0.131	42.549	6	18186.27	23232.186	1397.505	1397.505	1	1	H1-1b	
38	M140	PIPE2.0A21165	0.377	4.074	10	0.142	0	6	11590.083	23232.186	1397.505	1397.505	1	1	H1-1a	
39	M141	1.5X1.5X0.083	0.424	48.076	6	0.006	94.191	y	10	2676.388	14085.15	624.421	624.421	1.136	1	H1-1a
40	M142	PIPE2.0A21165	0.235	42.549	6	0.131	42.549	6	18186.27	23232.186	1397.505	1397.505	1	1	H1-1b	
41	M143	PIPE2.0A21165	0.287	4.074	6	0.143	0	6	11590.083	23232.186	1397.505	1397.505	1	1	H1-1b	
42	M144	1.5X1.5X0.083	0.43	48.076	6	0.005	94.191	y	10	2676.388	14085.15	624.421	624.421	1.136	1	H1-1a
43	M145	PIPE2.0A21165	0.231	42.549	6	0.133	42.549	6	18186.27	23232.186	1397.505	1397.505	1	1	H1-1b	

**Envelope AA ADM1-20: ASD - BUILDING Member Aluminum Code Checks**

Member	Shape	Code Check	Loc[in]	LcShear	Check	Loc[in]	DirLcPnc/om	[lb]	Pnt/om	[lb]	Mny/om	[lb-ft]	Mnz/om	[lb-ft]	Vny/om	[lb]	Vnz/om	[lb]	Cb	Eqn
1	M107	HR300 ALA	0.901	39.417	11	0.092	41.208	y	11	6230.805	14342.564	533.921	934.619	7307.692	3206.154	1.6	1	1	H.1-1	
2	M152	HR300 ALA	0.84	39.417	11	0.079	41.208	y	11	6230.805	14342.564	533.921	934.619	7307.692	3206.154	1.638	1	1	H.1-1	
3	M56	HR300 ALA	0.957	39.417	11	0.094	41.208	y	11	6230.805	14342.564	533.921	934.619	7307.692	3206.154	1.62	1	1	H.1-1	
4	M59	HR300 ALA	0.957	39.417	11	0.084	41.208	y	11	6230.805	14342.564	533.921	934.619	7307.692	3206.154	1.615	1	1	H.1-1	
5	M62	HR300 ALA	0.822	39.417	11	0.072	130.792	y	10	6230.805	14342.564	533.921	934.619	7307.692	3206.154	1.618	1	1	H.1-1	
6	M65	HR300 ALA	0.957	39.417	11	0.085	41.208	y	11	6230.805	14342.564	533.921	934.619	7307.692	3206.154	1.62	1	1	H.1-1	
7	M68	HR300 ALA	0.957	39.417	11	0.085	41.208	y	11	6230.805	14342.564	533.921	934.619	7307.692	3206.154	1.616	1	1	H.1-1	
8	M76	HR300 ALA	0.822	39.417	11	0.073	41.208	y	11	6230.805	14342.564	533.921	934.619	7307.692	3206.154	1.621	1	1	H.1-1	
9	M79	HR300 ALA	0.956	39.417	11	0.084	41.208	y	11	6230.805	14342.564	533.921	934.619	7307.692	3206.154	1.615	1	1	H.1-1	
10	M82	HR300 ALA	0.957	39.417	11	0.085	41.208	y	11	6230.805	14342.564	533.921	934.619	7307.692	3206.154	1.623	1	1	H.1-1	
11	M85	HR300 ALA	0.822	39.417	11	0.073	41.208	y	11	6230.805	14342.564	533.921	934.619	7307.692	3206.154	1.61	1	1	H.1-1	
12	M88	HR300 ALA	0.957	39.417	11	0.083	41.208	y	11	6230.805	14342.564	533.921	934.619	7307.692	3206.154	1.625	1	1	H.1-1	
13	M91	HR300 ALA	0.956	39.417	11	0.084	41.208	y	11	6230.805	14342.564	533.921	934.619	7307.692	3206.154	1.613	1	1	H.1-1	
14	M94	HR300 ALA	0.822	39.417	11	0.071	41.208	y	11	6230.805	14342.564	533.921	934.619	7307.692	3206.154	1.625	1	1	H.1-1	
15	M97	HR300 ALA	0.956	39.417	11	0.084	41.208	y	11	6230.805	14342.564	533.921	934.619	7307.692	3206.154	1.613	1	1	H.1-1	
16	M100	HR300 ALA	0.957	39.417	11	0.083	41.208	y	11	6230.805	14342.564	533.921	934.619	7307.692	3206.154	1.625	1	1	H.1-1	
17	M103	HR300 ALA	0.822	39.417	11	0.073	41.208	y	11	6230.805	14342.564	533.921	934.619	7307.692	3206.154	1.61	1	1	H.1-1	
18	M106	HR300 ALA	0.957	39.417	11	0.085	41.208	y	11	6230.805	14342.564	533.921	934.619	7307.692	3206.154	1.623	1	1	H.1-1	
19	M111	HR300 ALA	0.956	39.417	11	0.084	41.208	y	11	6230.805	14342.564	533.921	934.619	7307.692	3206.154	1.615	1	1	H.1-1	
20	M157	HR300 ALA	0.822	39.417	11	0.073	41.208	y	11	6230.805	14342.564	533.921	934.619	7307.692	3206.154	1.621	1	1	H.1-1	
21	M160	HR300 ALA	0.957	39.417	11	0.085	41.208	y	11	6230.805	14342.564	533.921	934.619	7307.692	3206.154	1.616	1	1	H.1-1	
22	M163	HR300 ALA	0.957	39.417	11	0.085	41.208	y	11	6230.805	14342.564	533.921	934.619	7307.692	3206.154	1.62	1	1	H.1-1	
23	M166	HR300 ALA	0.822	39.417	11	0.072	130.792	y	10	6230.805	14342.564	533.921	934.619	7307.692	3206.154	1.618	1	1	H.1-1	
24	M169	HR300 ALA	0.957	39.417	11	0.084	41.208	y	11	6230.805	14342.564	533.921	934.619	7307.692	3206.154	1.615	1	1	H.1-1	
25	M172	HR300 ALA	0.957	39.417	11	0.094	41.208	y	11	6230.805	14342.564	533.921	934.619	7307.692	3206.154	1.62	1	1	H.1-1	
26	M175	HR300 ALA	0.84	39.417	11	0.079	41.208	y	11	6230.805	14342.564	533.921	934.619	7307.692	3206.154	1.638	1	1	H.1-1	
27	M178	HR300 ALA	0.901	39.417	11	0.092	41.208	y	11	6230.805	14342.564	533.921	934.619	7307.692	3206.154	1.6	1	1	H.1-1	



JOB NO.: U2716.0385.241

PROJECT: SunTurf Package A16

SUBJECT: CALCULATIONS

DESIGN APPROACH ASD

CONNECTION CAPACITY

Location: Column Base (set screws)

Connection Type: M16 Conical Set Screws

Tensile Capacity: 2600 lbs

Tension Load: 1848 lbs

Check Connection: 71.1%

Result: **Select M16 Conical Set Screws**

Note: Uplift capacity. FOS of (2)

CONNECTION CAPACITY

Location: Column to Cross Beam

Connection Type: K10341-002

Tensile Capacity: 2195 lbs

Tension Load: 1526 lbs

Check Connection: 69.5%

Result: **Select K10341-002**

Note: Uplift capacity. FOS of (2)





JOB NO.: U2716.0385.241

PROJECT: SunTurf Package A16

SUBJECT: CALCULATIONS

---

**CONNECTION CAPACITY**

Location: Brace to Column

Connection Type: K10219-001

Capacity: 1570 lbs

Tension Load: 1110 lbs

Check Connection: 70.7%

Result: **Select K10219-001**

Note: Axial capacity. FOS of (2)

---

**BOLTED TENSION CONNECTION**

Location: Rail to Cross Beam

Bolt Grade: A304 SS (A2-70)

Bolt Diameter: 0.375 in

Number of Bolts: 2

Bolt Capacity: 8410 lbs (AISC Equation J3-1)

Tension Load: 816 lbs

Check Bolt: 9.7%

Result: **Select (2) 0.375 in. dia. A304 SS (A2-70) bolts.**

Note:

---



JOB NO.: U2716.0385.241

**PROJECT:** Sunturf Package A16 Ground Mount

---

# Framing Analysis

## LF - 35 deg

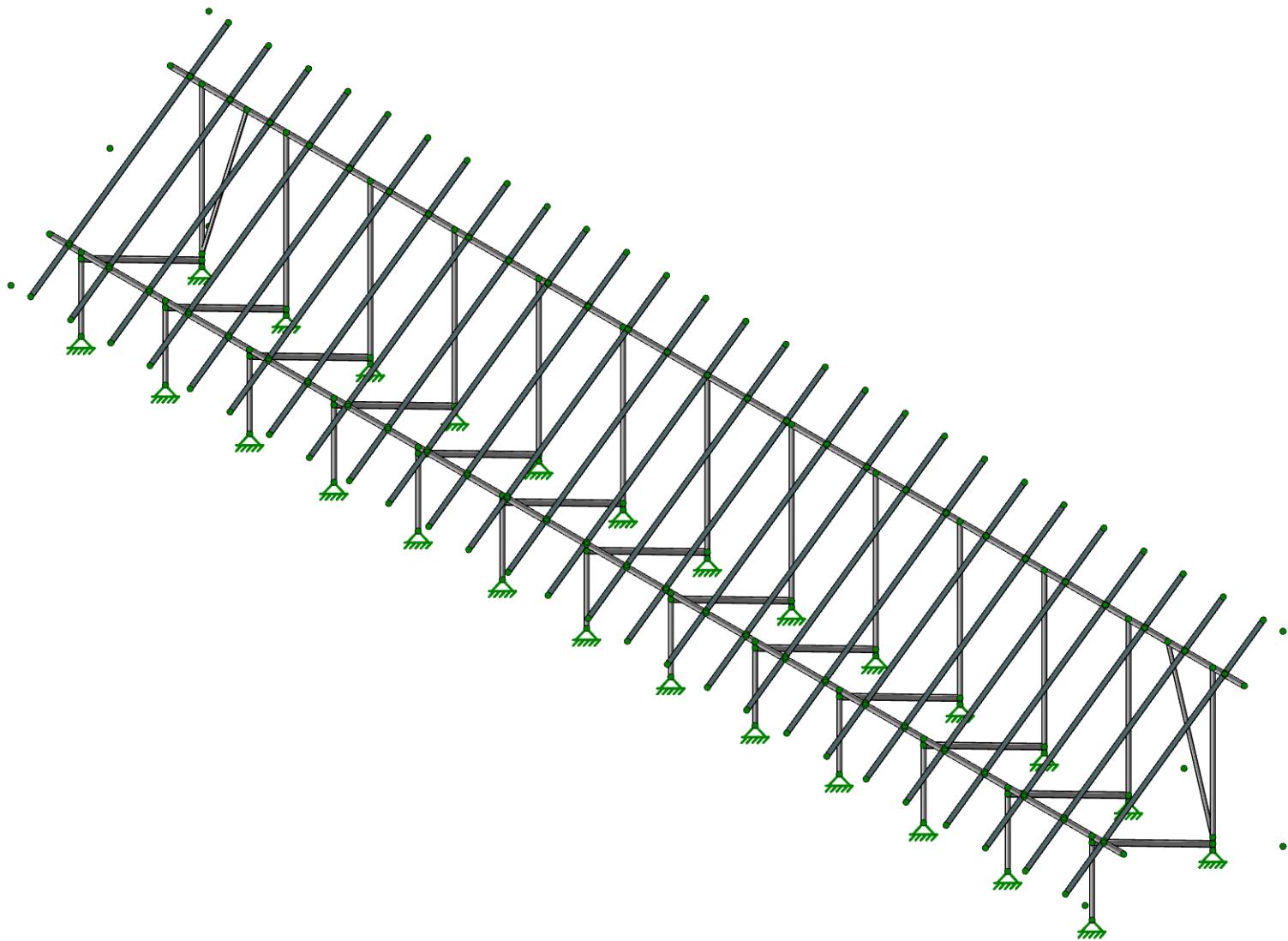
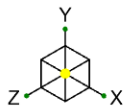

Vector Structural Engineering  
CJT  
U2716.0385.241

A16 Large Format Panels - 35 Degree Tilt

SK-1  
Mar 20, 2024  
Sunturf A16 - LF - 35deg.r3d

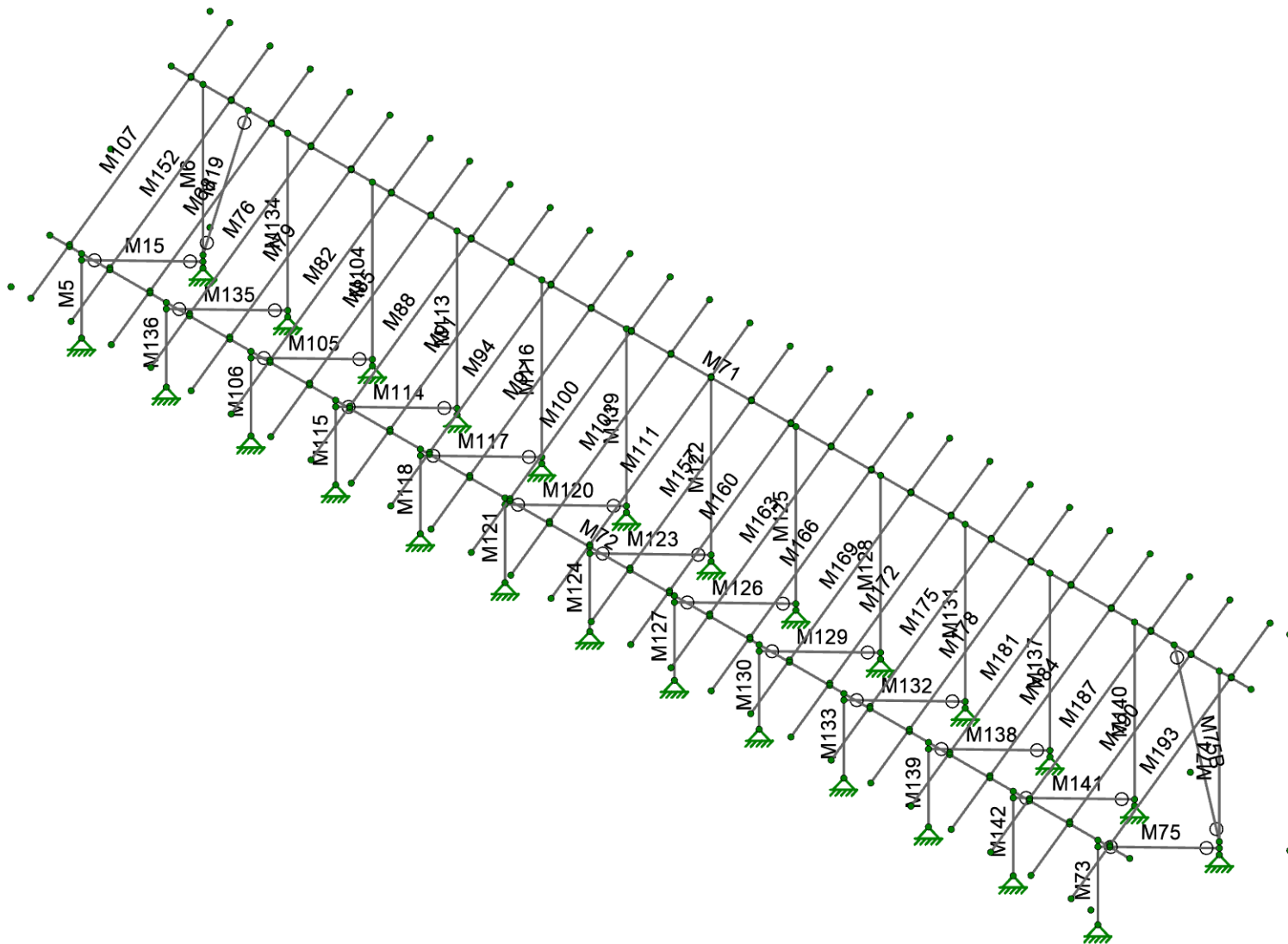
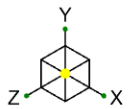

Vector Structural Engineering  
CJT  
U2716.0385.241

A16 Large Format Panels - 35 Degree Tilt

SK-2  
Mar 20, 2024  
Sunturf A16 - LF - 35deg.r3d

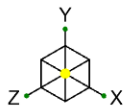

Section Sets	
<span style="color: blue;">█</span>	Post
<span style="color: green;">█</span>	Cross Beam
<span style="color: red;">█</span>	Diagonal Brace
<span style="color: grey;">█</span>	Double Brace
<span style="color: magenta;">█</span>	RIGID
<span style="color: cyan;">█</span>	AL Rails

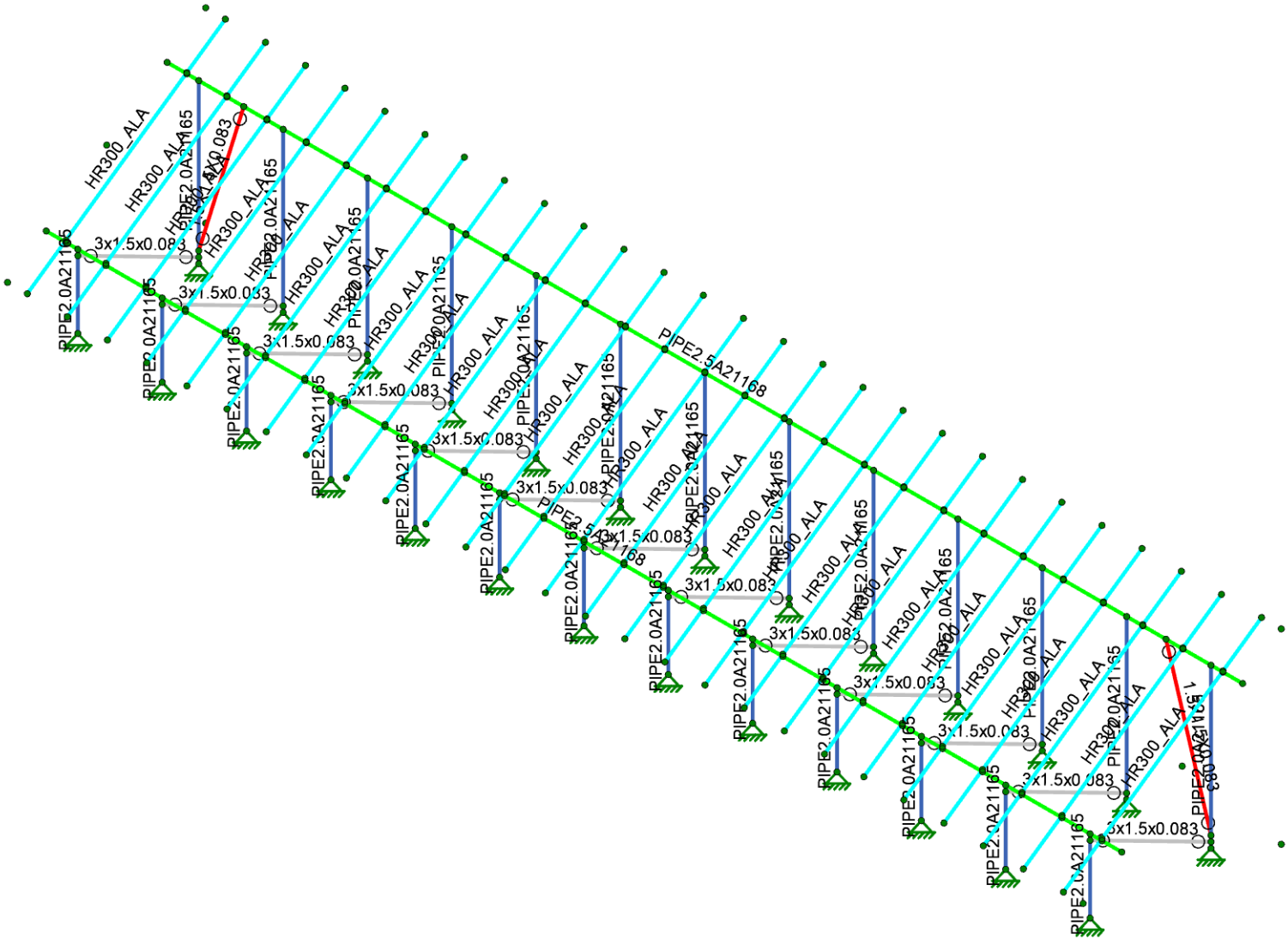

Vector Structural Engineering  
 CJT  
 U2716.0385.241

A16 Large Format Panels - 35 Degree Tilt

SK-3  
 Mar 20, 2024  
 Sunturf A16 - LF - 35deg.r3d

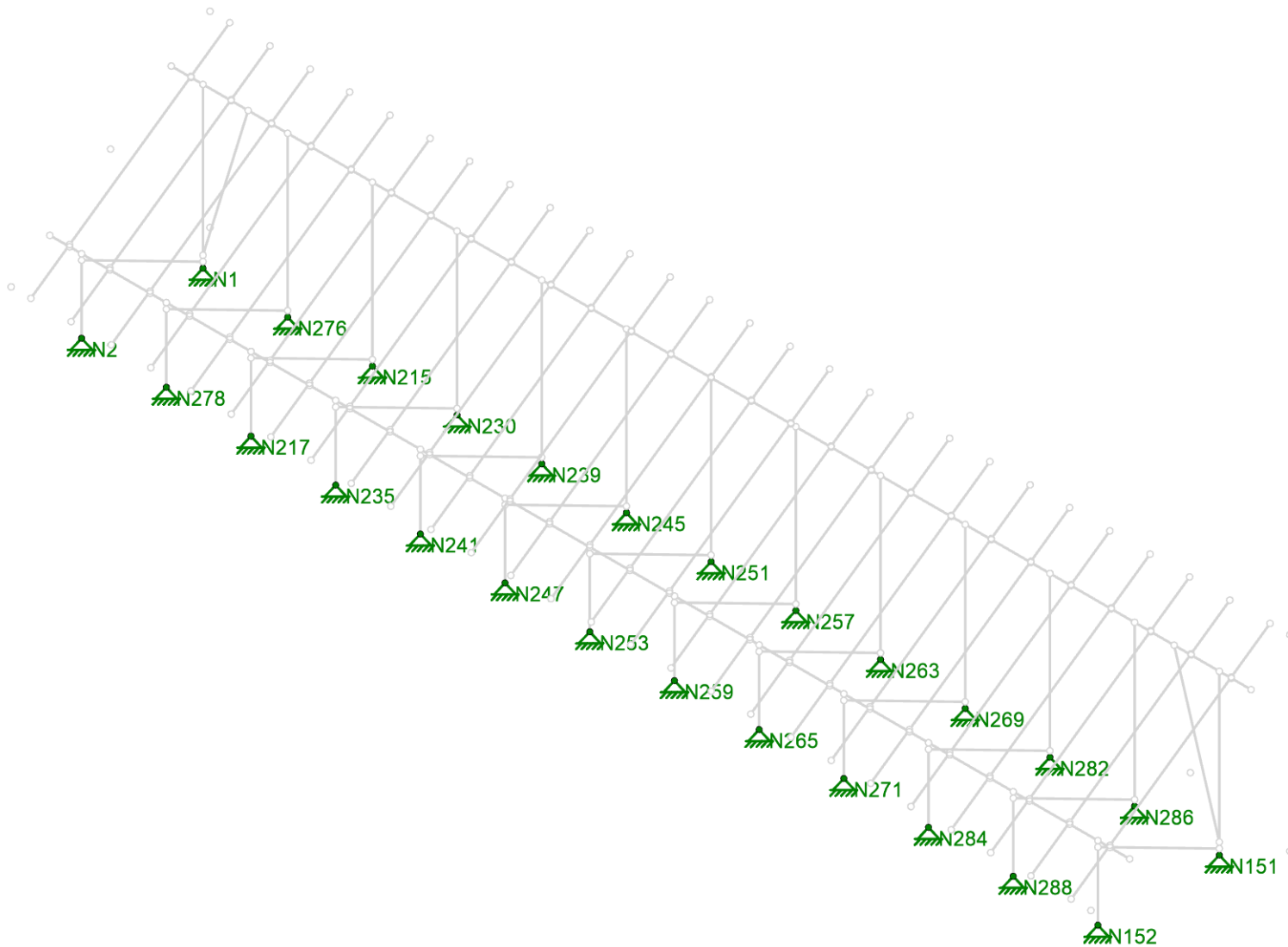
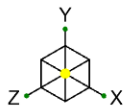

Vector Structural Engineering  
 CJT  
 U2716.0385.241

A16 Large Format Panels - 35 Degree Tilt

SK-4  
 Mar 20, 2024  
 Sunturf A16 - LF - 35deg.r3d

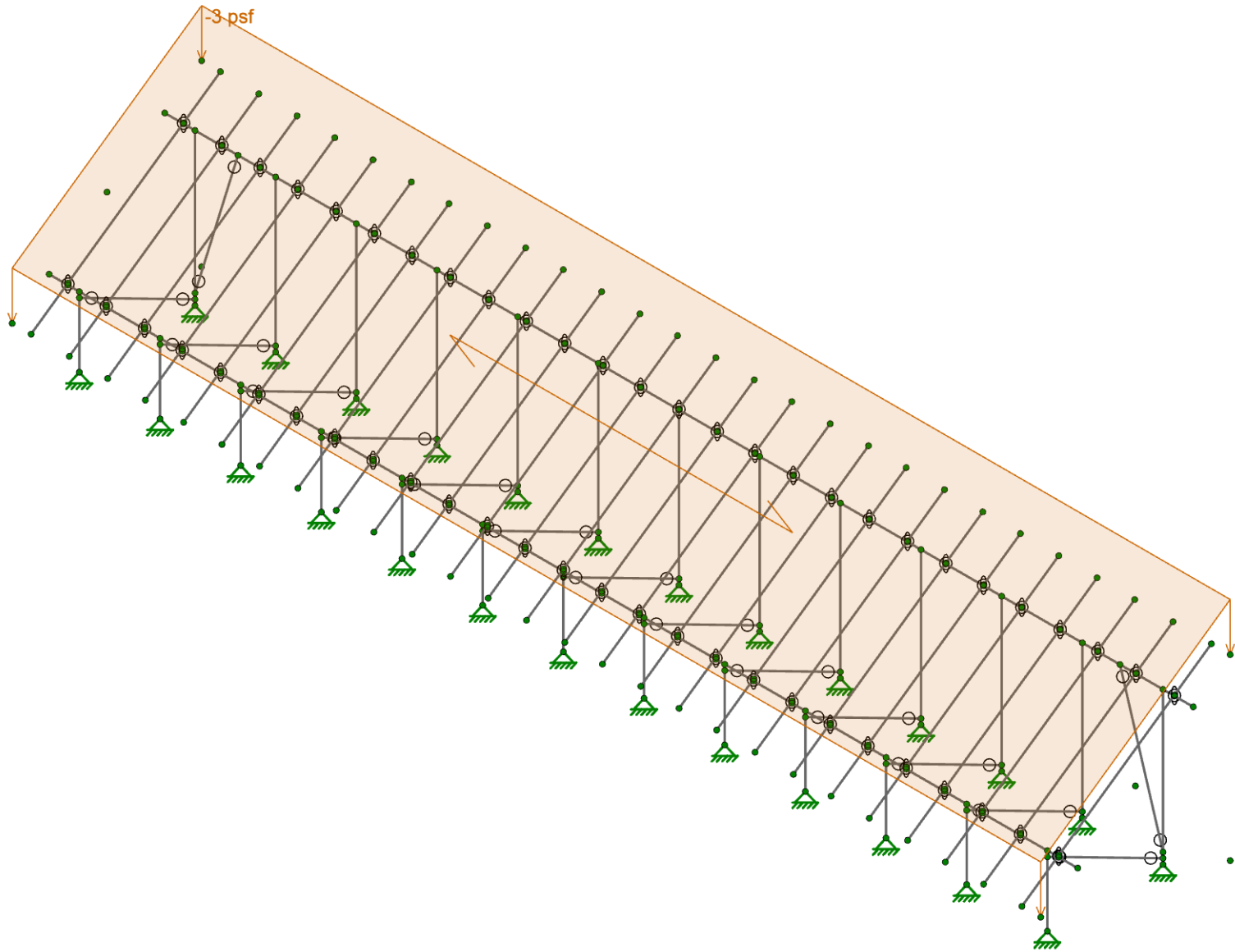
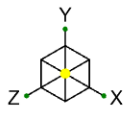

Loads: BLC 2, Solar Panel Weight



Vector Structural Engineering  
CJT  
U2716.0385.241

A16 Large Format Panels - 35 Degree Tilt

SK-5  
Mar 20, 2024  
Sunturf A16 - LF - 35deg.r3d

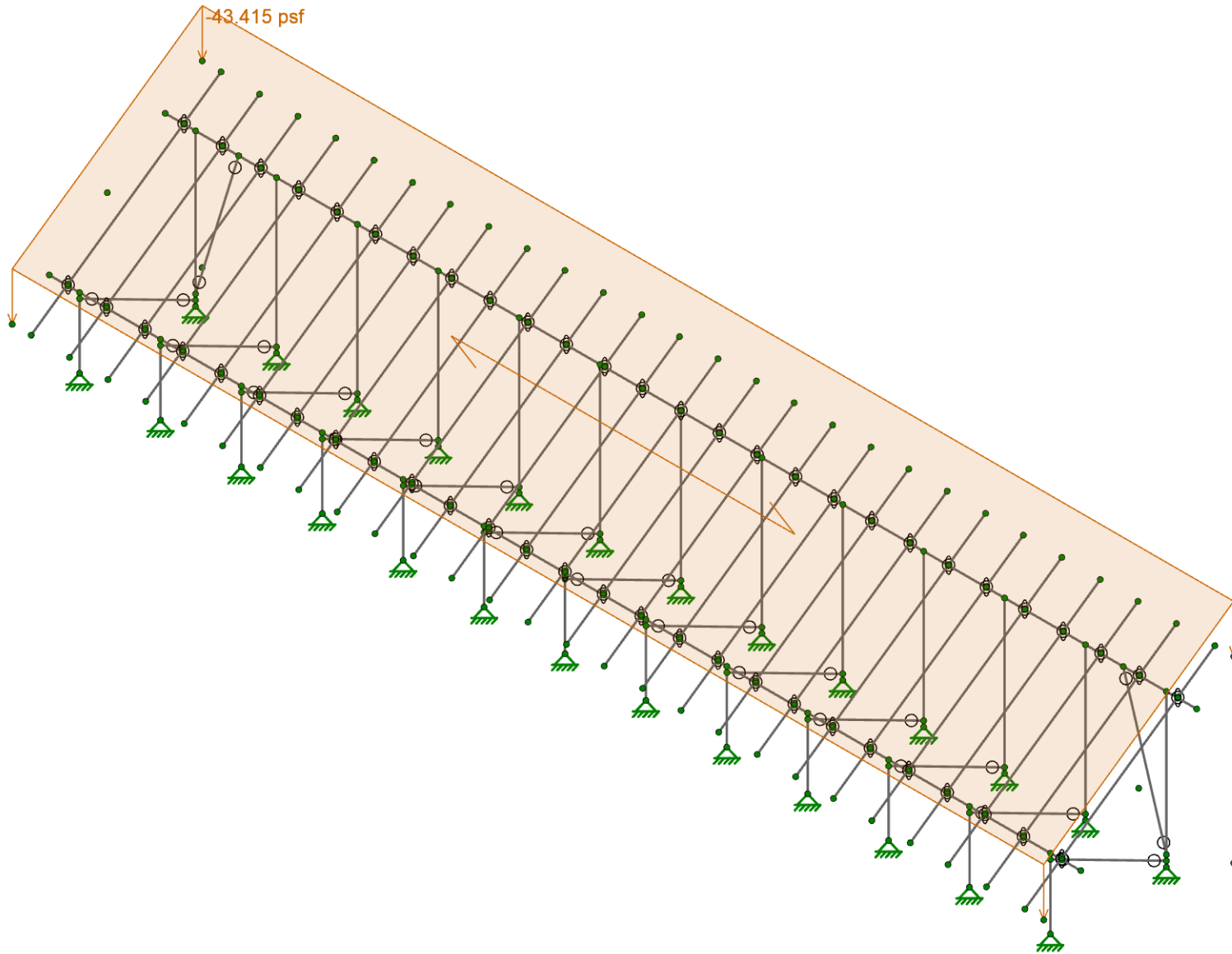
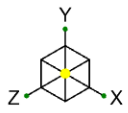

Loads: BLC 3, Roof Live/Snow



Vector Structural Engineering  
CJT  
U2716.0385.241

A16 Large Format Panels - 35 Degree Tilt

SK-6  
Mar 20, 2024  
Sunturf A16 - LF - 35deg.r3d



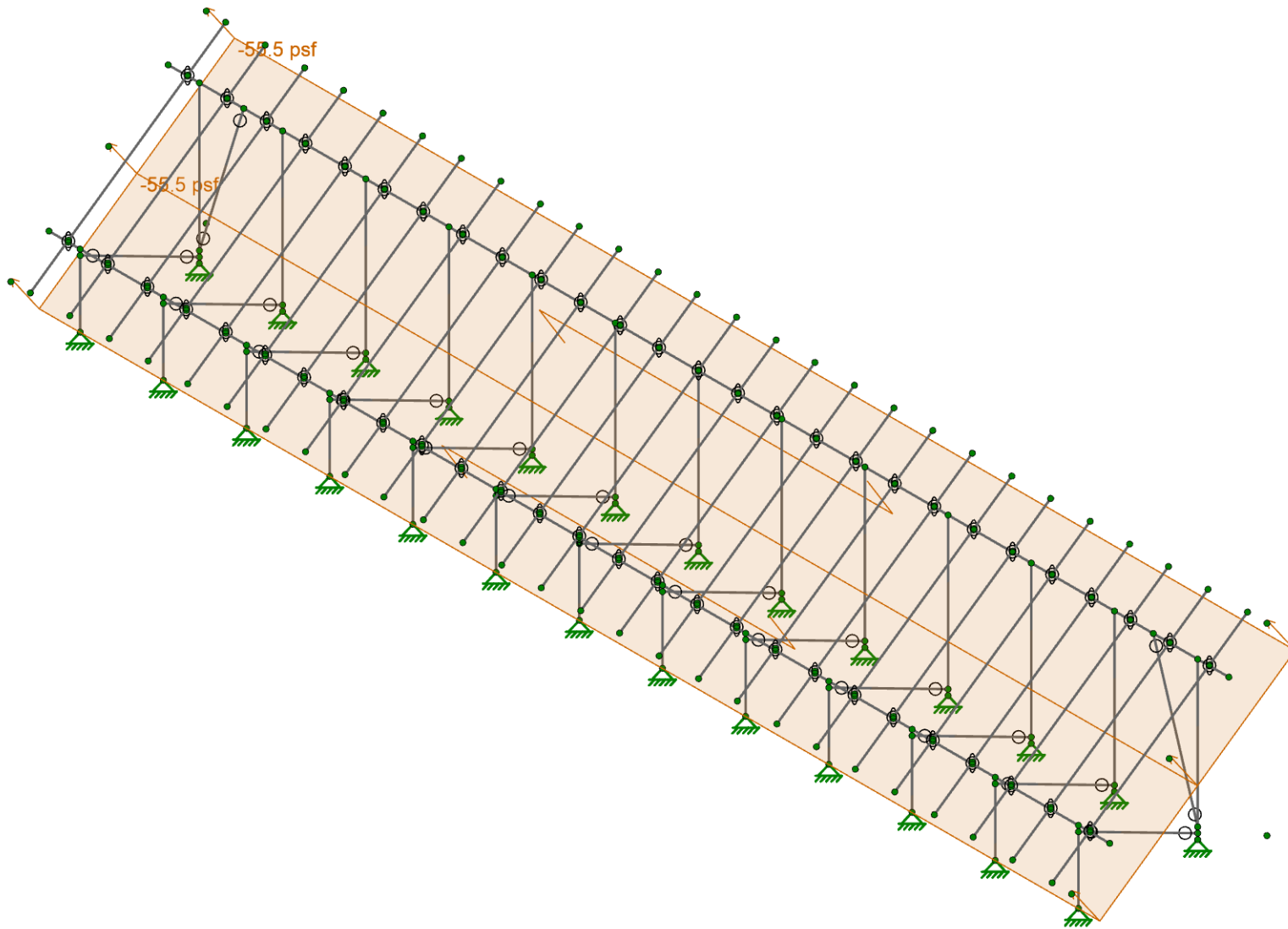
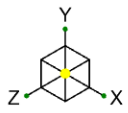

Loads: BLC 4, Wind A 0 deg



Vector Structural Engineering  
CJT  
U2716.0385.241

A16 Large Format Panels - 35 Degree Tilt

SK-7  
Mar 20, 2024  
Sunturf A16 - LF - 35deg.r3d

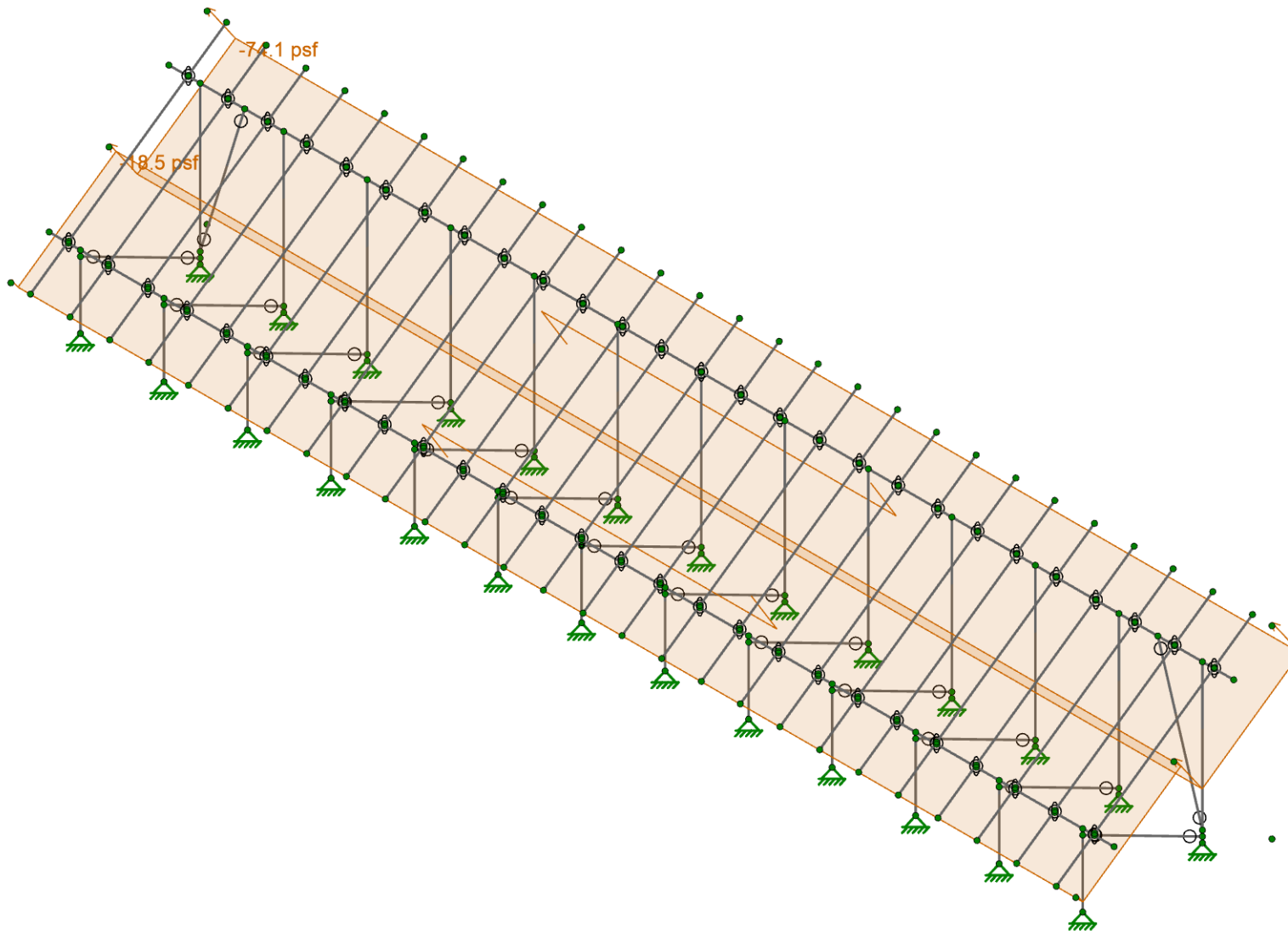
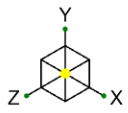

Loads: BLC 5, Wind B 0 deg



Vector Structural Engineering  
CJT  
U2716.0385.241

A16 Large Format Panels - 35 Degree Tilt

SK-8  
Mar 20, 2024  
Sunturf A16 - LF - 35deg.r3d

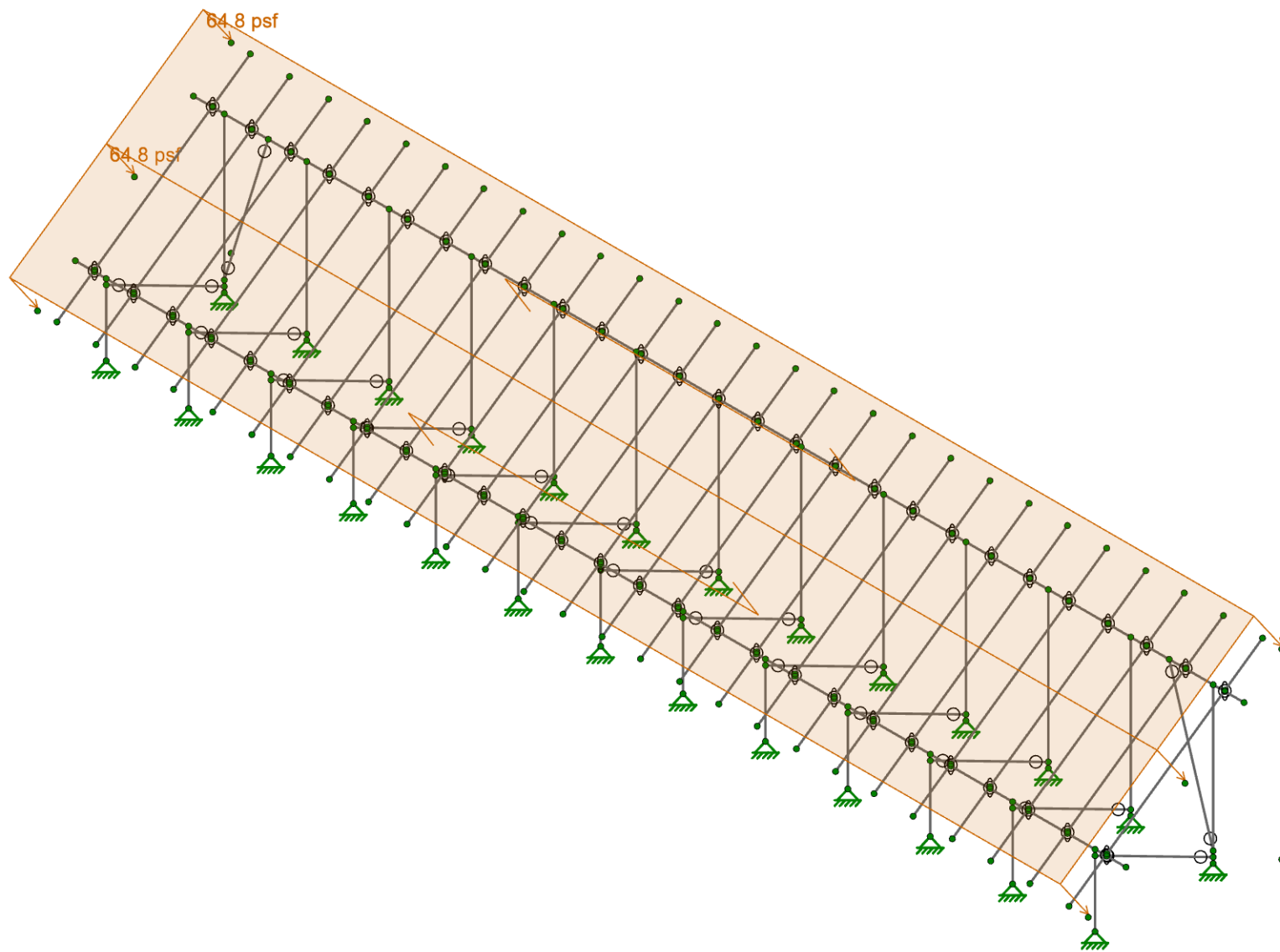
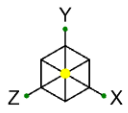

Loads: BLC 6, Wind A 180 deg



Vector Structural Engineering  
CJT  
U2716.0385.241

A16 Large Format Panels - 35 Degree Tilt

SK-9  
Mar 20, 2024  
Sunturf A16 - LF - 35deg.r3d

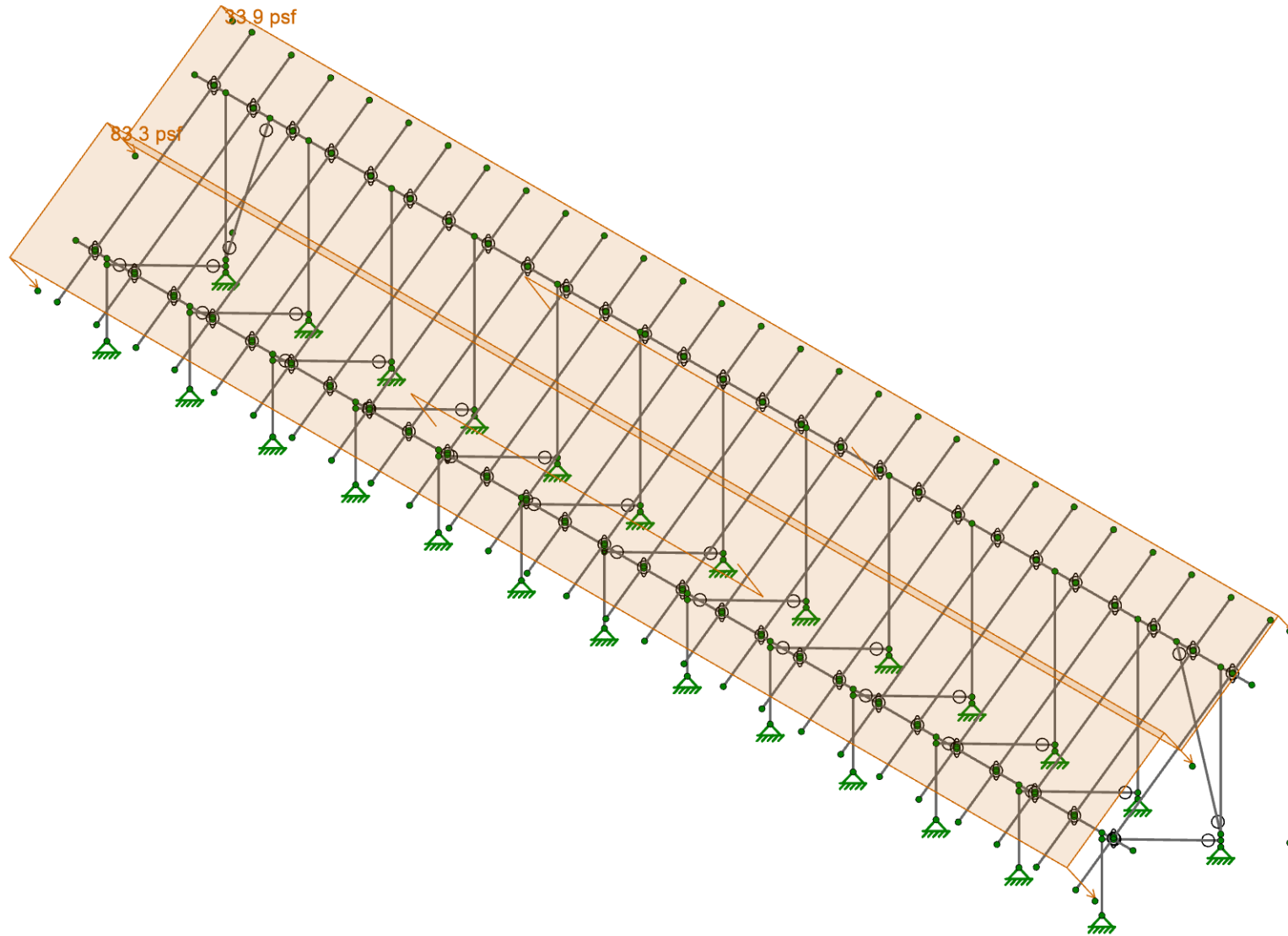
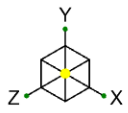

Loads: BLC 7, Wind B 180 deg



Vector Structural Engineering  
CJT  
U2716.0385.241

A16 Large Format Panels - 35 Degree Tilt

SK-10  
Mar 20, 2024  
Sunturf A16 - LF - 35deg.r3d

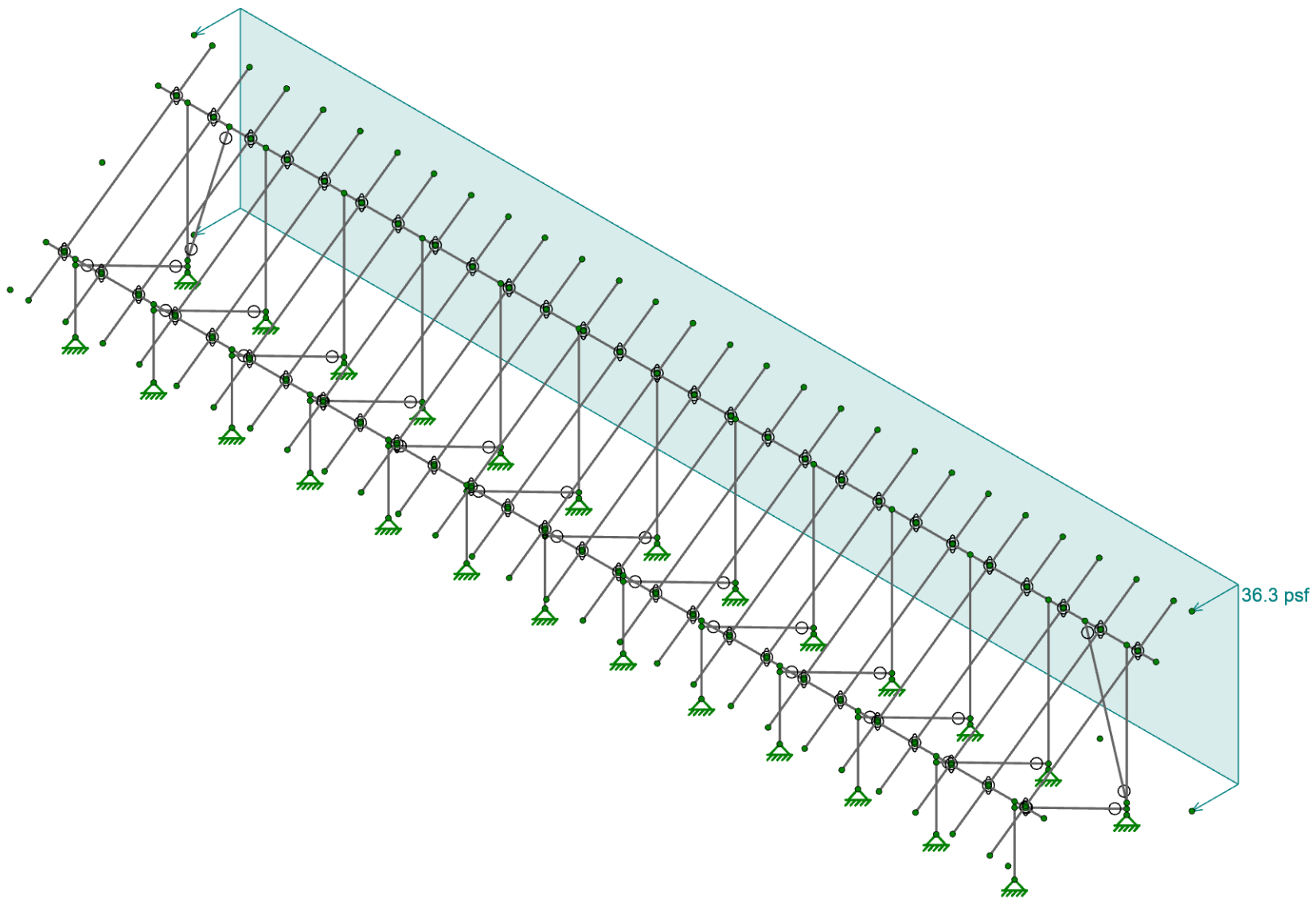
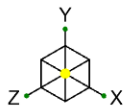

Loads: BLC 8, Wind Z



Vector Structural Engineering  
CJT  
U2716.0385.241

A16 Large Format Panels - 35 Degree Tilt

SK-11  
Mar 20, 2024  
Sunturf A16 - LF - 35deg.r3d

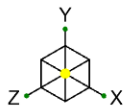

Code Check (Env)

- No Calc
- > 1.0
- .90-1.0
- .75-.90
- .50-.75
- 0-.50

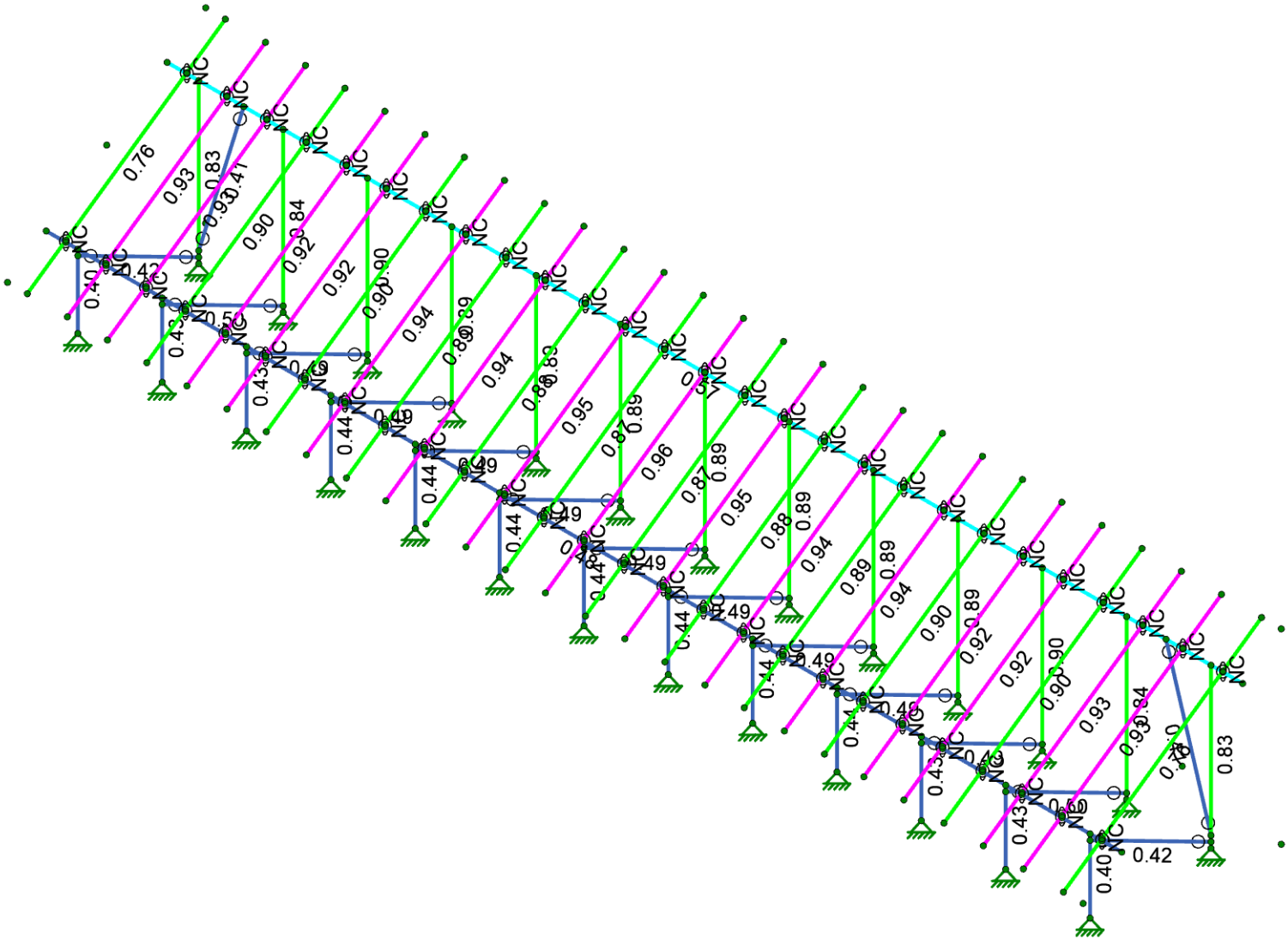

Member Code Checks Displayed (Enveloped)

 <p>IRISA A NEMETSCHKE COMPANY</p>	Vector Structural Engineering	A16 Large Format Panels - 35 Degree Tilt	SK-12
	CJT		Mar 20, 2024
	U2716.0385.241		Sunturf A16 - LF - 35deg.r3d

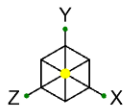

Shear Check (Env)

- No Calc
- > 1.0
- .90-1.0
- .75-90
- .50-75
- 0-.50

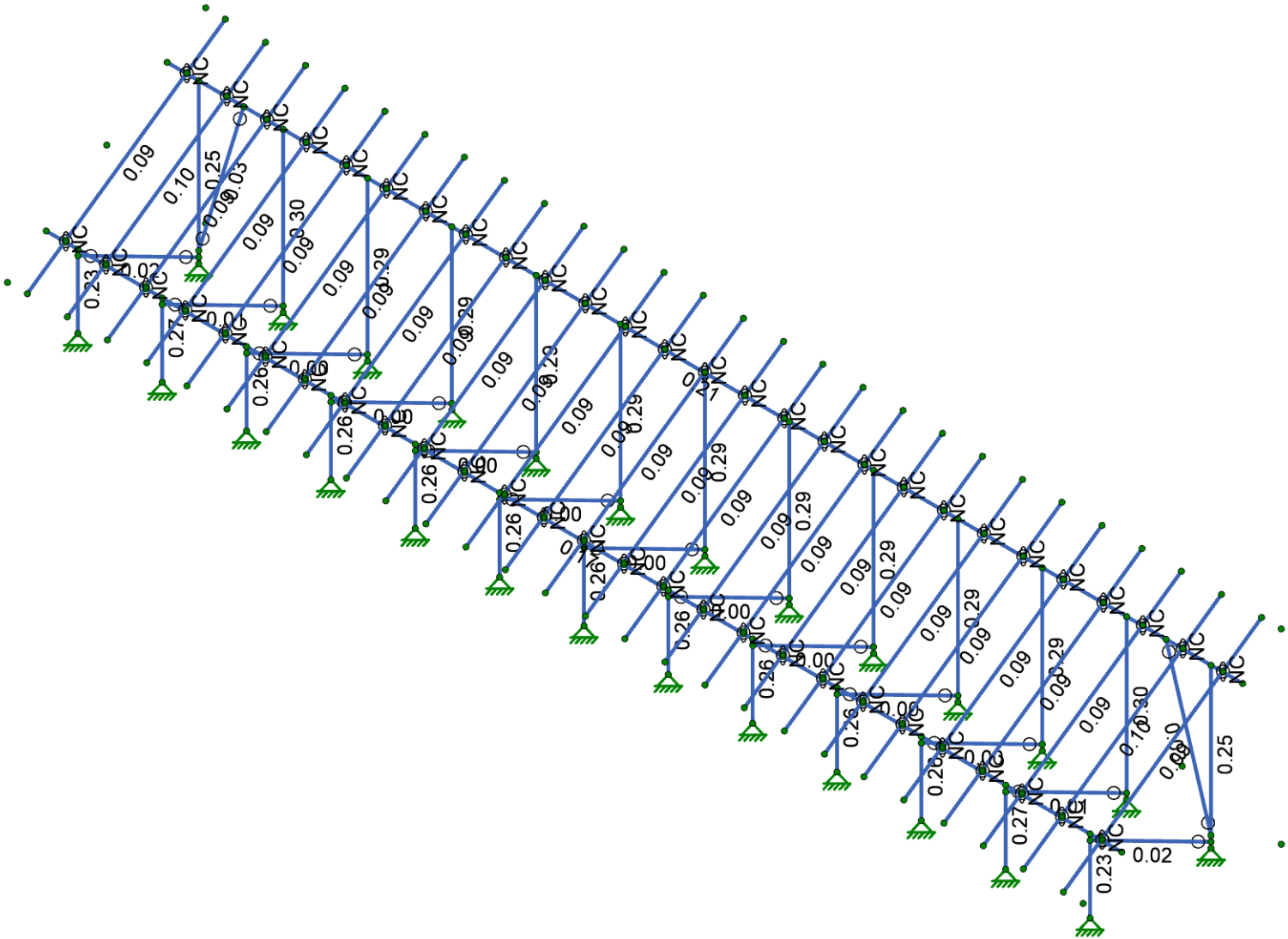

Member Shear Checks Displayed (Enveloped)

 <p>IRISA A NEMETSCHKE COMPANY</p>	Vector Structural Engineering	A16 Large Format Panels - 35 Degree Tilt	SK-13
	CJT		Mar 20, 2024
	U2716.0385.241	Sunturf A16 - LF - 35deg.r3d	

**Model Settings**

Number of Reported Sections	5
Number of Internal Sections	100
Member Area Load Mesh Size (in <sup>2</sup> )	144
Consider Shear Deformation	Yes
Consider Torsional Warping	Yes
Approximate Mesh Size (in)	24
Transfer Forces Between Intersecting Wood Walls	Yes
Increase Wood Wall Nailing Capacity for Wind Loads	Yes
Include P-Delta for Walls	Yes
Optimize Masonry and Wood Walls	Yes
Maximum Number of Iterations	3
Single	No
Multiple (Optimum)	Yes
Maximum	No

Global Axis corresponding to vertical direction	Y
Convert Existing Data	Yes
Default Global Plane for z-axis	XZ
Plate Local Axis Orientation	Nodal

Hot Rolled Steel	AISC 15th (360-16): ASD
Stiffness Adjustment	Yes (Iterative)
Notional Annex	None
Connections	None
Cold Formed Steel	None
Stiffness Adjustment	Yes (Iterative)
Wood	None
Temperature	< 100F
Concrete	ACI 318-19
Masonry	None
Aluminum	AA ADM1-20: ASD
Structure Type	Building
Stiffness Adjustment	Yes (Iterative)
Stainless	None
Stiffness Adjustment	Yes (Iterative)

Compression Stress Block	Rectangular Stress Block
Analyze using Cracked Sections	No
Leave room for horizontal rebar splices (2*d bar spacing)	Yes
List forces which were ignored for design in the Detail Report	Yes

Column Min Steel	1
Column Max Steel	8
Rebar Material Spec	ASTM A615
Warn if beam-column framing arrangement is not understood	No
Number of Shear Regions	4
Region 2 & 3 Spacing Increase Increment (in)	3.999992





Company : Vector Structural Engineering  
Designer : CJT  
Job Number : U2716.0385.241  
Model Name : A16 Large Format Panels - 35 D...

3/20/2024  
2:21:33 PM  
Checked By : MIH

---

---

**Model Settings (Continued)**

T Z (sec)	
T X (sec)	
C <sub>Z</sub>	0.02
C <sub>X</sub>	0.02
R Z	3
R X	3

**Hot Rolled Steel Properties**

	Label	E [ksi]	G [ksi]	Nu	Therm. Coeff. [1e <sup>5</sup> F <sup>-1</sup> ]	Density [lb/ft <sup>3</sup> ]	Yield [psi]	Ry	Fu [psi]	Rt
1	A992	29000	11154	0.3	0.65	490	50000	1.1	65000	1.1
2	A36 Gr.36	29000	11154	0.3	0.65	490	36000	1.5	58000	1.2
3	A572 Gr.50	29000	11154	0.3	0.65	490	50000	1.1	65000	1.1
4	A500 Gr.B RND	29000	11154	0.3	0.65	527	42000	1.4	58000	1.3
5	A500 Gr.B Rect	29000	11154	0.3	0.65	527	46000	1.4	58000	1.3
6	A53 Gr.B	29000	11154	0.3	0.65	490	35000	1.6	60000	1.2
7	A1085	29000	11154	0.3	0.65	490	50000	1.4	65000	1.3

**Aluminum Properties**

	Label	E [ksi]	G [ksi]	Nu	Therm. Coeff. [1e <sup>5</sup> F <sup>-1</sup> ]	Density [lb/ft <sup>3</sup> ]	Table B.4	kt	Ftu [psi]	Fty [psi]	Fcy [psi]	Fsu [psi]	Ct
1	3003-H14	10100	3787.5	0.33	1.3	172.8	Table B.4-1	1	19000	16000	13000	12000	141
2	6061-T6	10100	3787.5	0.33	1.3	172.8	Table B.4-2	1	38000	35000	35000	24000	141
3	6063-T5	10100	3787.5	0.33	1.3	172.8	Table B.4-2	1	22000	16000	16000	13000	141
4	6063-T6	10100	3787.5	0.33	1.3	172.8	Table B.4-2	1	30000	25000	25000	19000	141
5	5052-H34	10200	3787.5	0.33	1.3	172.8	Table B.4-1	1	34000	26000	24000	20000	141
6	6061-T6 W	10100	3787.5	0.33	1.3	172.8	Table B.4-1	1	24000	15000	15000	15000	141
7	6005-T5	10100	3787.5	0.33	1.3	172.8	Table B.4-1	1	38000	35000	35000	24000	141

**Hot Rolled Steel Section Sets**

	Label	Shape	Type	Design List	Material	Design Rule	Area [in <sup>2</sup> ]	Iyy [in <sup>4</sup> ]	Izz [in <sup>4</sup> ]	J [in <sup>4</sup> ]
1	Post	PIPE2.0A21165	Column	Pipe	A572 Gr.50	Typical	0.776	0.499	0.499	0.998
2	Cross Beam	PIPE2.5A21168	Beam	Wide Flange	A572 Gr.50	Typical	0.947	0.907	0.907	1.814
3	Diagonal Brace	1.5X1.5X0.083	HBrace	Square Tube	A572 Gr.50	Typical	0.47	0.158	0.158	0.236
4	Double Brace	3x1.5x0.083	HBrace	Tube	A572 Gr.50	Typical	0.719	0.283	0.845	0.654

**Aluminum Section Sets**

	Label	Shape	Type	Design List	Material	Design Rule	Area [in <sup>2</sup> ]	Iyy [in <sup>4</sup> ]	Izz [in <sup>4</sup> ]	J [in <sup>4</sup> ]
1	AL Posts	2.375ODX0.188	Column	Pipe	6005-T5	Typical	1.29	0.778	0.778	1.54
2	AL Brace	RT4x1.5x0.15625	VBrace	Rectangular Tubes	6005-T5	Typical	1.619	0.61	3.034	1.605
3	AL Rails	HR300 ALA	Beam	Rectangular Tubes	6005-T5	Typical	0.736	0.214	0.727	0.734
4	AL Cross Beam	CROSSRAIL	Beam	Rectangular Tubes	6005-T5	Typical	1.909	1.97	4.366	4.017

**Basic Load Cases**

	BLC Description	Category	Y Gravity	Distributed	Area(Member)
1	Self Weight	DL	-1.05		
2	Solar Panel Weight	DL			1
3	Roof Live/Snow	RLL			1
4	Wind A 0 deg	OL1			2
5	Wind B 0 deg	OL2			2
6	Wind A 180 deg	OL3			2
7	Wind B 180 deg	OL4			2
8	Wind Z	WLZ			1
9	BLC 2 Transient Area Loads	None		51	
10	BLC 3 Transient Area Loads	None		51	
11	BLC 4 Transient Area Loads	None		172	
12	BLC 5 Transient Area Loads	None		172	
13	BLC 6 Transient Area Loads	None		172	
14	BLC 7 Transient Area Loads	None		172	
15	BLC 8 Transient Area Loads	None		109	

**Member Area Loads (BLC 2 : Solar Panel Weight)**

Node A	Node B	Node C	Node D	Direction	Load Direction	A Magnitude [psf]	B Magnitude [psf]	C Magnitude [psf]	D Magnitude [psf]	Exclude Braces	
1	N197	N200	N199	N196	Y	A-B	-3	-3	-3	-3	Yes

**Member Area Loads (BLC 3 : Roof Live/Snow)**

Node A	Node B	Node C	Node D	Direction	Load Direction	A Magnitude [psf]	B Magnitude [psf]	C Magnitude [psf]	D Magnitude [psf]	Exclude Braces	
1	N197	N200	N199	N196	PY	A-B	-53	-53	-53	-53	Yes

**Member Area Loads (BLC 4 : Wind A 0 deg)**

Node A	Node B	Node C	Node D	Direction	Load Direction	A Magnitude [psf]	B Magnitude [psf]	C Magnitude [psf]	D Magnitude [psf]	Exclude Braces	
1	N197	N200	N201	N198	Perp	A-B	-55.5	-55.5	-55.5	-55.5	Yes
2	N198	N201	N199	N196	Perp	A-B	-55.5	-55.5	-55.5	-55.5	Yes

**Member Area Loads (BLC 5 : Wind B 0 deg)**

Node A	Node B	Node C	Node D	Direction	Load Direction	A Magnitude [psf]	B Magnitude [psf]	C Magnitude [psf]	D Magnitude [psf]	Exclude Braces	
1	N197	N200	N201	N198	Perp	A-B	-74.1	-74.1	-74.1	-74.1	Yes
2	N198	N201	N199	N196	Perp	A-B	-18.5	-18.5	-18.5	-18.5	Yes

**Member Area Loads (BLC 6 : Wind A 180 deg)**

Node A	Node B	Node C	Node D	Direction	Load Direction	A Magnitude [psf]	B Magnitude [psf]	C Magnitude [psf]	D Magnitude [psf]	Exclude Braces	
1	N197	N200	N201	N198	Perp	A-B	64.8	64.8	64.8	64.8	Yes
2	N198	N201	N199	N196	Perp	A-B	64.8	64.8	64.8	64.8	Yes

**Member Area Loads (BLC 7 : Wind B 180 deg)**

Node A	Node B	Node C	Node D	Direction	Load Direction	A Magnitude [psf]	B Magnitude [psf]	C Magnitude [psf]	D Magnitude [psf]	Exclude Braces	
1	N197	N200	N201	N198	Perp	A-B	33.9	33.9	33.9	33.9	Yes
2	N198	N201	N199	N196	Perp	A-B	83.3	83.3	83.3	83.3	Yes

**Member Area Loads (BLC 8 : Wind Z)**

Node A	Node B	Node C	Node D	Direction	Load Direction	A Magnitude [psf]	B Magnitude [psf]	C Magnitude [psf]	D Magnitude [psf]	Exclude Braces	
1	N200	N197	N307	N308	Z	Open Structure	36.3	36.3	36.3	36.3	Yes

**Load Combinations**

	Description	Solve	P-Delta	BLC	Factor	BLC	Factor	BLC	Factor	BLC	Factor
1	ASD Loads		Y								
2	1.0 D	Yes	Y	DL	1						
3	1.0 D + 1.0 S	Yes	Y	DL	1	RLL	1				
4	1.0 D + 0.6 W1	Yes	Y	DL	1	RLL		OL1	0.6	WLZ	0.6
5	1.0 D + 0.6 W2	Yes	Y	DL	1	RLL		OL2	0.6	WLZ	0.6
6	1.0 D + 0.6 W3	Yes	Y	DL	1	RLL		OL3	0.6	WLZ	-0.6
7	1.0 D + 0.6 W4	Yes	Y	DL	1	RLL		OL4	0.6	WLZ	-0.6
8	1.0 D + 0.45 W1 + 0.75 S	Yes	Y	DL	1	RLL	0.75	OL1	0.45	WLZ	0.45
9	1.0 D + 0.45 W2 + 0.75 S	Yes	Y	DL	1	RLL	0.75	OL2	0.45	WLZ	0.45
10	1.0 D + 0.45 W3 + 0.75 S	Yes	Y	DL	1	RLL	0.75	OL3	0.45	WLZ	-0.45
11	1.0 D + 0.45 W4 + 0.75 S	Yes	Y	DL	1	RLL	0.75	OL4	0.45	WLZ	-0.45
12	0.6 D + 0.6 W1	Yes	Y	DL	0.6	RLL		OL1	0.6	WLZ	0.6
13	0.6 D + 0.6 W2	Yes	Y	DL	0.6	RLL		OL2	0.6	WLZ	0.6

**Load Combinations (Continued)**

	Description	Solve	P-Delta	BLC	Factor	BLC	Factor	BLC	Factor	BLC	Factor
14	0.6 D + 0.6 W3	Yes	Y	DL	0.6	RLL		OL3	0.6	WLZ	-0.6
15	0.6 D + 0.6 W4	Yes	Y	DL	0.6	RLL		OL4	0.6	WLZ	-0.6
16			Y								
17	LRFD Loads		Y								
18	1.4 D		Y	DL	1.4	RLL					
19	1.2 D + 1.6 S + 0.5 W1		Y	DL	1.2	RLL	1.6	OL1	0.5		
20	1.2 D + 1.6 S + 0.5 W2		Y	DL	1.2	RLL	1.6	OL2	0.5		
21	1.2 D + 1.6 S + 0.5 W3		Y	DL	1.2	RLL	1.6	OL3	0.5		
22	1.2 D + 1.6 S + 0.5 W4		Y	DL	1.2	RLL	1.6	OL4	0.5		
23	1.2 D + 1.0 W1		Y	DL	1.2	RLL		OL1	1		
24	1.2 D + 1.0 W2		Y	DL	1.2	RLL		OL2	1		
25	1.2 D + 1.0 W3		Y	DL	1.2	RLL		OL3	1		
26	1.2 D + 1.0 W4		Y	DL	1.2	RLL		OL4	1		
27	0.9 D + 1.0 W1		Y	DL	0.9	RLL		OL1	1		
28	0.9 D + 1.0 W2		Y	DL	0.9	RLL		OL2	1		
29	0.9 D + 1.0 W3		Y	DL	0.9	RLL		OL3	1		
30	0.9 D + 1.0 W4		Y	DL	0.9	RLL		OL4	1		

**Envelope Node Reactions**

	Node Label		X [lb]	LC	Y [lb]	LC	Z [lb]	LC	MX [lb-ft]	LC	MY [lb-ft]	LC	MZ [lb-ft]	LC
1	N2	max	15.342	11	1788.535	9	109.373	4	0	15	0	15	0	15
2		min	-3.658	12	-382.105	14	-126.507	6	0	2	0	2	0	2
3	N1	max	203.768	10	3424.346	10	1633.781	6	0	15	0	15	0	15
4		min	-131.122	13	-2457.034	13	-1422.947	4	0	2	0	2	0	2
5	N151	max	131.126	13	3424.289	10	1633.801	6	0	15	0	15	0	15
6		min	-203.772	10	-2457.049	13	-1422.964	4	0	2	0	2	0	2
7	N152	max	3.654	12	1788.594	9	109.374	4	0	15	0	15	0	15
8		min	-15.334	11	-382.117	14	-126.507	6	0	2	0	2	0	2
9	N276	max	6.459	10	3037.643	10	1933.745	6	0	15	0	15	0	15
10		min	-4.323	13	-2254.587	13	-1675.738	4	0	2	0	2	0	2
11	N278	max	1.579	14	2151.664	9	119.289	4	0	15	0	15	0	15
12		min	-4.749	9	-460.694	14	-137.696	6	0	2	0	2	0	2
13	N215	max	0.889	13	3534.572	10	1884.595	6	0	15	0	15	0	15
14		min	-1.122	10	-2582.451	13	-1641.197	4	0	2	0	2	0	2
15	N217	max	1.271	9	2085.022	9	120.852	4	0	15	0	15	0	15
16		min	-0.473	14	-447.037	14	-139.312	6	0	2	0	2	0	2
17	N230	max	1.159	10	3451.79	10	1896.177	6	0	15	0	15	0	15
18		min	-0.773	13	-2524.209	13	-1646.786	4	0	2	0	2	0	2
19	N235	max	2.697	9	2093.204	9	121.542	4	0	15	0	15	0	15
20		min	-1.352	14	-449.22	14	-140.235	6	0	2	0	2	0	2
21	N239	max	1.088	10	3471.408	10	1896.045	6	0	15	0	15	0	15
22		min	-0.758	13	-2540.076	13	-1648.062	4	0	2	0	2	0	2
23	N241	max	3.796	9	2094.088	9	121.806	4	0	15	0	15	0	15
24		min	-1.841	14	-449.57	14	-140.488	6	0	2	0	2	0	2
25	N245	max	1.207	10	3460.977	10	1893.198	6	0	15	0	15	0	15
26		min	-0.81	13	-2530.731	13	-1645.253	4	0	2	0	2	0	2
27	N247	max	3.397	9	2087.652	9	121.797	4	0	15	0	15	0	15
28		min	-1.044	14	-444.606	14	-140.52	6	0	2	0	2	0	2
29	N251	max	0	7	3465.555	10	1897.732	6	0	15	0	15	0	15
30		min	0	13	-2537.296	13	-1649.419	4	0	2	0	2	0	2
31	N253	max	0	13	2091.038	9	121.953	4	0	15	0	15	0	15
32		min	0	3	-450.244	14	-140.625	6	0	2	0	2	0	2
33	N257	max	0.809	13	3460.968	10	1893.2	6	0	15	0	15	0	15
34		min	-1.208	10	-2530.724	13	-1645.254	4	0	2	0	2	0	2
35	N259	max	1.045	14	2087.654	9	121.796	4	0	15	0	15	0	15

**Envelope Node Reactions (Continued)**

Node Label		X [lb]	LC	Y [lb]	LC	Z [lb]	LC	MX [lb-ft]	LC	MY [lb-ft]	LC	MZ [lb-ft]	LC
36		min	9	-3.397	14	-444.605	6	0	2	0	2	0	2
37	N263	max	13	0.757	10	3471.403	6	0	15	0	15	0	15
38		min	10	-1.088	13	-2540.068	4	0	2	0	2	0	2
39	N265	max	14	1.84	9	2094.082	4	0	15	0	15	0	15
40		min	9	-3.796	14	-449.543	6	0	2	0	2	0	2
41	N269	max	13	0.772	10	3451.799	6	0	15	0	15	0	15
42		min	10	-1.16	13	-2524.214	4	0	2	0	2	0	2
43	N271	max	14	1.352	9	2093.207	4	0	15	0	15	0	15
44		min	9	-2.697	14	-449.218	6	0	2	0	2	0	2
45	N282	max	10	1.121	10	3534.591	6	0	15	0	15	0	15
46		min	13	-0.89	13	-2582.474	4	0	2	0	2	0	2
47	N284	max	14	0.473	9	2085.034	4	0	15	0	15	0	15
48		min	9	-1.272	14	-447.055	6	0	2	0	2	0	2
49	N286	max	13	4.322	10	3037.778	6	0	15	0	15	0	15
50		min	10	-6.458	13	-2254.658	4	0	2	0	2	0	2
51	N288	max	9	4.748	9	2151.685	4	0	15	0	15	0	15
52		min	14	-1.581	14	-460.803	6	0	2	0	2	0	2
53	Totals:	max	13	0.001	10	55905.062	6						
54		min	6	0	12	-22329.622	12						

**Envelope AISC 15TH (360-16): ASD Member Steel Code Checks**

Member	Shape	Code Check	Loc[in]	LC	Shear	Check	Loc[in]	Dir	LC	Pnc/om [lb]	Pnt/om [lb]	Mnyy/om [lb-ft]	Mnzz/om [lb-ft]	Cb	Eqn
1	M5	PIPE2.0A21165	0.395	47.586	14	0.227	48.127	6	17103.062	23232.186	1397.505	1397.505	1	H1-1b	
2	M6	PIPE2.0A21165	0.835	3.524	10	0.254	0	6	5900.631	23232.186	1397.505	1397.505	1	H1-1a	
3	M15	3x1.5x0.083	0.423	51.299	6	0.019	96.563	y 10	4563.671	21540.24	952.46	1737.715	1.136	H1-1a	
4	M19	1.5X1.5X0.083	0.408	68.465	10	0.035	109.544	y 6	1978.736	14085.15	624.421	624.421	1.136	H1-1a	
5	M73	PIPE2.0A21165	0.395	47.586	14	0.227	48.127	6	17103.062	23232.186	1397.505	1397.505	1	H1-1b	
6	M74	PIPE2.0A21165	0.835	3.524	10	0.254	0	6	5900.631	23232.186	1397.505	1397.505	1	H1-1a	
7	M75	3x1.5x0.083	0.423	51.299	6	0.019	96.562	y 10	4563.702	21540.24	952.46	1737.715	1.136	H1-1a	
8	M75B	1.5X1.5X0.083	0.408	68.465	10	0.035	109.544	y 6	1978.736	14085.15	624.421	624.421	1.136	H1-1a	
9	M71	PIPE2.5A21168	0.568	143.438	10	0.212	262.969	10	20336.2	28358.413	2081.747	2081.747	1	H1-1b	
10	M72	PIPE2.5A21168	0.476	621.563	11	0.172	262.969	11	20336.2	28358.413	2081.747	2081.747	1	H1-1b	
11	M134	PIPE2.0A21165	0.844	3.524	6	0.296	0	6	5900.631	23232.186	1397.505	1397.505	1	H1-1a	
12	M135	3x1.5x0.083	0.5	51.299	6	0.009	96.562	y 10	4563.702	21540.24	952.46	1737.715	1.136	H1-1a	
13	M136	PIPE2.0A21165	0.43	47.586	14	0.268	48.127	6	17103.062	23232.186	1397.505	1397.505	1	H1-1b	
14	M104	PIPE2.0A21165	0.897	3.524	6	0.292	0	6	5900.631	23232.186	1397.505	1397.505	1	H1-1a	
15	M105	3x1.5x0.083	0.488	51.299	6	0.003	96.562	y 10	4563.702	21540.24	952.46	1737.715	1.136	H1-1a	
16	M106	PIPE2.0A21165	0.434	47.586	14	0.259	48.127	6	17103.062	23232.186	1397.505	1397.505	1	H1-1b	
17	M113	PIPE2.0A21165	0.888	3.524	6	0.293	0	6	5900.631	23232.186	1397.505	1397.505	1	H1-1a	
18	M114	3x1.5x0.083	0.49	51.299	6	0.003	96.562	y 9	4563.702	21540.24	952.46	1737.715	1.136	H1-1a	
19	M115	PIPE2.0A21165	0.437	47.586	14	0.26	48.127	6	17103.062	23232.186	1397.505	1397.505	1	H1-1b	
20	M116	PIPE2.0A21165	0.891	3.524	6	0.293	0	6	5900.631	23232.186	1397.505	1397.505	1	H1-1a	
21	M117	3x1.5x0.083	0.49	51.299	6	0.003	96.562	y 9	4563.702	21540.24	952.46	1737.715	1.136	H1-1a	
22	M118	PIPE2.0A21165	0.437	47.586	14	0.26	48.127	6	17103.062	23232.186	1397.505	1397.505	1	H1-1b	
23	M119	PIPE2.0A21165	0.889	3.524	6	0.292	0	6	5900.631	23232.186	1397.505	1397.505	1	H1-1a	
24	M120	3x1.5x0.083	0.49	51.299	6	0.003	96.562	y 9	4563.702	21540.24	952.46	1737.715	1.136	H1-1a	
25	M121	PIPE2.0A21165	0.437	47.586	14	0.26	48.127	6	17103.062	23232.186	1397.505	1397.505	1	H1-1b	
26	M122	PIPE2.0A21165	0.89	3.524	6	0.293	0	6	5900.631	23232.186	1397.505	1397.505	1	H1-1a	
27	M123	3x1.5x0.083	0.491	51.299	6	0.001	96.562	y 10	4563.702	21540.24	952.46	1737.715	1.136	H1-1a	
28	M124	PIPE2.0A21165	0.438	47.586	14	0.26	48.127	6	17103.062	23232.186	1397.505	1397.505	1	H1-1b	
29	M125	PIPE2.0A21165	0.889	3.524	6	0.292	0	6	5900.631	23232.186	1397.505	1397.505	1	H1-1a	
30	M126	3x1.5x0.083	0.49	51.299	6	0.003	96.562	y 9	4563.702	21540.24	952.46	1737.715	1.136	H1-1a	
31	M127	PIPE2.0A21165	0.437	47.586	14	0.26	48.127	6	17103.062	23232.186	1397.505	1397.505	1	H1-1b	
32	M128	PIPE2.0A21165	0.891	3.524	6	0.293	0	6	5900.631	23232.186	1397.505	1397.505	1	H1-1a	
33	M129	3x1.5x0.083	0.49	51.299	6	0.003	96.562	y 9	4563.702	21540.24	952.46	1737.715	1.136	H1-1a	

**Envelope AISC 15TH (360-16): ASD Member Steel Code Checks (Continued)**

Member	Shape	Code Check	Loc[in]	LC	Shear	Check	Loc[in]	Dir	LC	Pnc/om [lb]	Pnt/om [lb]	Mnyy/om [lb-ft]	Mnzz/om [lb-ft]	Cb	Eqn
34	M130	PIPE2.0A21165	0.437	47.586	14	0.26	48.127	6	17103.062	23232.186	1397.505	1397.505	1	H1-1b	
35	M131	PIPE2.0A21165	0.888	3.524	6	0.293	0	6	5900.631	23232.186	1397.505	1397.505	1	H1-1a	
36	M132	3x1.5x0.083	0.49	51.299	6	0.003	96.562	y	9	4563.702	21540.24	952.46	1737.715	1.136	H1-1a
37	M133	PIPE2.0A21165	0.437	47.586	14	0.26	48.127	6	17103.062	23232.186	1397.505	1397.505	1	H1-1b	
38	M137	PIPE2.0A21165	0.897	3.524	6	0.292	0	6	5900.631	23232.186	1397.505	1397.505	1	H1-1a	
39	M138	3x1.5x0.083	0.488	51.299	6	0.003	96.562	y	10	4563.702	21540.24	952.46	1737.715	1.136	H1-1a
40	M139	PIPE2.0A21165	0.434	47.586	14	0.259	48.127	6	17103.062	23232.186	1397.505	1397.505	1	H1-1b	
41	M140	PIPE2.0A21165	0.844	3.524	6	0.296	0	6	5900.631	23232.186	1397.505	1397.505	1	H1-1a	
42	M141	3x1.5x0.083	0.5	51.299	6	0.009	96.562	y	10	4563.702	21540.24	952.46	1737.715	1.136	H1-1a
43	M142	PIPE2.0A21165	0.43	47.586	14	0.268	48.127	6	17103.062	23232.186	1397.505	1397.505	1	H1-1b	

**Envelope AA ADM1-20: ASD - BUILDING Member Aluminum Code Checks**

Member	Shape	Code Check	Loc[in]	LC	Shear	Check	Loc[in]	Dir	LC	Pnc/Om [lb]	Pnt/Om [lb]	Mny/Om [lb-ft]	Mnz/Om [lb-ft]	Vny/Om [lb]	Vnz/Om [lb]	Cb	Eqn
1	M107	HR300 ALA	0.764	86	10	0.09	34.042	y	11	3387.058	14342.564	533.921	934.619	7307.692	3206.154	1.393	H.1-1
2	M152	HR300 ALA	0.931	86	10	0.096	34.042	y	11	3387.058	14342.564	533.921	934.619	7307.692	3206.154	1.413	H.1-1
3	M68	HR300 ALA	0.931	86	10	0.094	34.042	y	11	3387.058	14342.564	533.921	934.619	7307.692	3206.154	1.41	H.1-1
4	M76	HR300 ALA	0.896	86	10	0.089	34.042	y	11	3387.058	14342.564	533.921	934.619	7307.692	3206.154	1.408	H.1-1
5	M79	HR300 ALA	0.923	86	10	0.09	34.042	y	11	3387.058	14342.564	533.921	934.619	7307.692	3206.154	1.409	H.1-1
6	M82	HR300 ALA	0.919	86	10	0.088	34.042	y	11	3387.058	14342.564	533.921	934.619	7307.692	3206.154	1.409	H.1-1
7	M85	HR300 ALA	0.898	86	10	0.088	34.042	y	11	3387.058	14342.564	533.921	934.619	7307.692	3206.154	1.408	H.1-1
8	M88	HR300 ALA	0.937	86	10	0.089	34.042	y	11	3387.058	14342.564	533.921	934.619	7307.692	3206.154	1.41	H.1-1
9	M91	HR300 ALA	0.886	86	10	0.089	34.042	y	11	3387.058	14342.564	533.921	934.619	7307.692	3206.154	1.408	H.1-1
10	M94	HR300 ALA	0.94	86	10	0.088	34.042	y	11	3387.058	14342.564	533.921	934.619	7307.692	3206.154	1.41	H.1-1
11	M97	HR300 ALA	0.883	87.792	10	0.089	34.042	y	11	3387.058	14342.564	533.921	934.619	7307.692	3206.154	1.407	H.1-1
12	M100	HR300 ALA	0.946	86	10	0.088	34.042	y	11	3387.058	14342.564	533.921	934.619	7307.692	3206.154	1.41	H.1-1
13	M103	HR300 ALA	0.865	86	10	0.089	34.042	y	11	3387.058	14342.564	533.921	934.619	7307.692	3206.154	1.407	H.1-1
14	M111	HR300 ALA	0.955	86	10	0.089	34.042	y	11	3387.058	14342.564	533.921	934.619	7307.692	3206.154	1.41	H.1-1
15	M157	HR300 ALA	0.865	86	10	0.089	34.042	y	11	3387.058	14342.564	533.921	934.619	7307.692	3206.154	1.407	H.1-1
16	M160	HR300 ALA	0.946	86	10	0.088	34.042	y	11	3387.058	14342.564	533.921	934.619	7307.692	3206.154	1.41	H.1-1
17	M163	HR300 ALA	0.883	87.792	10	0.089	34.042	y	11	3387.058	14342.564	533.921	934.619	7307.692	3206.154	1.407	H.1-1
18	M166	HR300 ALA	0.94	86	10	0.088	34.042	y	11	3387.058	14342.564	533.921	934.619	7307.692	3206.154	1.41	H.1-1
19	M169	HR300 ALA	0.886	86	10	0.089	34.042	y	11	3387.058	14342.564	533.921	934.619	7307.692	3206.154	1.408	H.1-1
20	M172	HR300 ALA	0.937	86	10	0.089	34.042	y	11	3387.058	14342.564	533.921	934.619	7307.692	3206.154	1.41	H.1-1
21	M175	HR300 ALA	0.898	86	10	0.088	34.042	y	11	3387.058	14342.564	533.921	934.619	7307.692	3206.154	1.408	H.1-1
22	M178	HR300 ALA	0.919	86	10	0.088	34.042	y	11	3387.058	14342.564	533.921	934.619	7307.692	3206.154	1.409	H.1-1
23	M181	HR300 ALA	0.923	86	10	0.09	34.042	y	11	3387.058	14342.564	533.921	934.619	7307.692	3206.154	1.409	H.1-1
24	M184	HR300 ALA	0.896	86	10	0.089	34.042	y	11	3387.058	14342.564	533.921	934.619	7307.692	3206.154	1.408	H.1-1
25	M187	HR300 ALA	0.931	86	10	0.094	34.042	y	11	3387.058	14342.564	533.921	934.619	7307.692	3206.154	1.41	H.1-1
26	M190	HR300 ALA	0.931	86	10	0.096	34.042	y	11	3387.058	14342.564	533.921	934.619	7307.692	3206.154	1.413	H.1-1
27	M193	HR300 ALA	0.763	86	10	0.09	34.042	y	11	3387.058	14342.564	533.921	934.619	7307.692	3206.154	1.393	H.1-1



JOB NO.: U2716.0385.241

PROJECT: SunTurf Package A16

SUBJECT: CALCULATIONS

DESIGN APPROACH ASD

CONNECTION CAPACITY

Location: Column Base (set screws)

Connection Type: M16 Conical Set Screws

Tensile Capacity: 2600 lbs

Tension Load: 2583 lbs

Check Connection: 99%

Result: **Select M16 Conical Set Screws**

Note: Uplift capacity. FOS of (2)

CONNECTION CAPACITY

Location: Column to Cross Beam

Connection Type: K10341-002

Tensile Capacity: 2195 lbs

Tension Load: 1881 lbs

Check Connection: 85.7%

Result: **Select K10341-002**

Note: Uplift capacity. FOS of (2)



JOB NO.: U2716.0385.241

PROJECT: SunTurf Package A16

SUBJECT: CALCULATIONS

---

**CONNECTION CAPACITY**

Location: Brace to Column

Connection Type: K10219-001

Capacity: 3125 lbs

Tension Load: 2244 lbs

Check Connection: 71.8%

Result: **Select K10219-001**

Note: Axial capacity. FOS of (2). N-S braces doubled

---

**BOLTED TENSION CONNECTION**

Location: Rail to Cross Beam

Bolt Grade: A304 SS (A2-70)

Bolt Diameter: 0.375 in

Number of Bolts: 2

Bolt Capacity: 8410 lbs (AISC Equation J3-1)

Tension Load: 1137 lbs

Check Bolt: 13.5%

Result: **Select (2) 0.375 in. dia. A304 SS (A2-70) bolts.**

Note:

---





JOB NO.: U2716.0385.241

**PROJECT:** Sunturf Package A16 Ground Mount

---

# ALTERNATE FOUNDATION OPTION 1: DRILLED CONCRETE PIER



PROJECT: Sunturf Package A16 Ground Mount

**DRILLED CONCRETE PIER DESIGN**

**Column Reactions:**

Max. Shear, V [k]:	1.9	Max. Down, P <sub>d</sub> [k]:	3.6
Max. Moment, M [k-ft]:	0.0	Max. Uplift, P <sub>u</sub> [k]:	2.6

**Pier Properties:**

Pier Shape:	Round	Volume of Concrete [ft <sup>3</sup> ]:	16
Pier Diameter, b [ft]:	2.0	Volume of Concrete [yd <sup>3</sup> ]:	0.6
Top of Pier Elevation [ft]:	0.00	Weight of Concrete [k]:	2.4
Pier Depth, d [ft]:	5.0		

**Soil Properties:**

Allow. Bearing Pressure [psf]:	1,500	<u>Optional Parameters for Uplift:</u>	
1/3 increase for short term loads?	No		
Lateral Bearing, S [pcf]:	150	Skin Friction* [psf]:	250
Max. Lateral Bearing (opt'l) [psf]:		Top Length to Ignore [ft]:	0
Top Depth to Ignore [ft]:	0	1/3 increase for short term loads?	No
1/3 increase for short term loads?	No	Combine w/ Bearing:	No
1/2" deflection at t/o pier allowed:	Yes		

\*per IBC Section 1810.3.3.1.4

**Check Bearing:**

Bearing Capacity [k]:	7.9
-----------------------	-----

**Bearing capacity OK.**

**Check Uplift:**

Uplift Capacity [k]:	10.0
----------------------	------

**Uplift capacity OK.**

**Check Lateral Bearing:**

Top of Pier Constrained?:	No
Applied Lateral Force, P [lb]:	1,940
Point of Application, h [ft]:	0.0
S <sub>max</sub> [psf]:	
S [psf]:	500
A = 2.34*P/(S <sub>b</sub> ):	4.54
Required Pier Depth, d <sub>reqd</sub> [ft]:	4.50

IBC Section 1807.3.2.1

IBC Eq. 18-1

Result: **Lateral bearing capacity OK.**



JOB NO.: U2716.0385.241

**PROJECT:** Sunturf Package A16 Ground Mount

---

# ALTERNATE FOUNDATION OPTION 2: CONCRETE BALLAST BLOCK

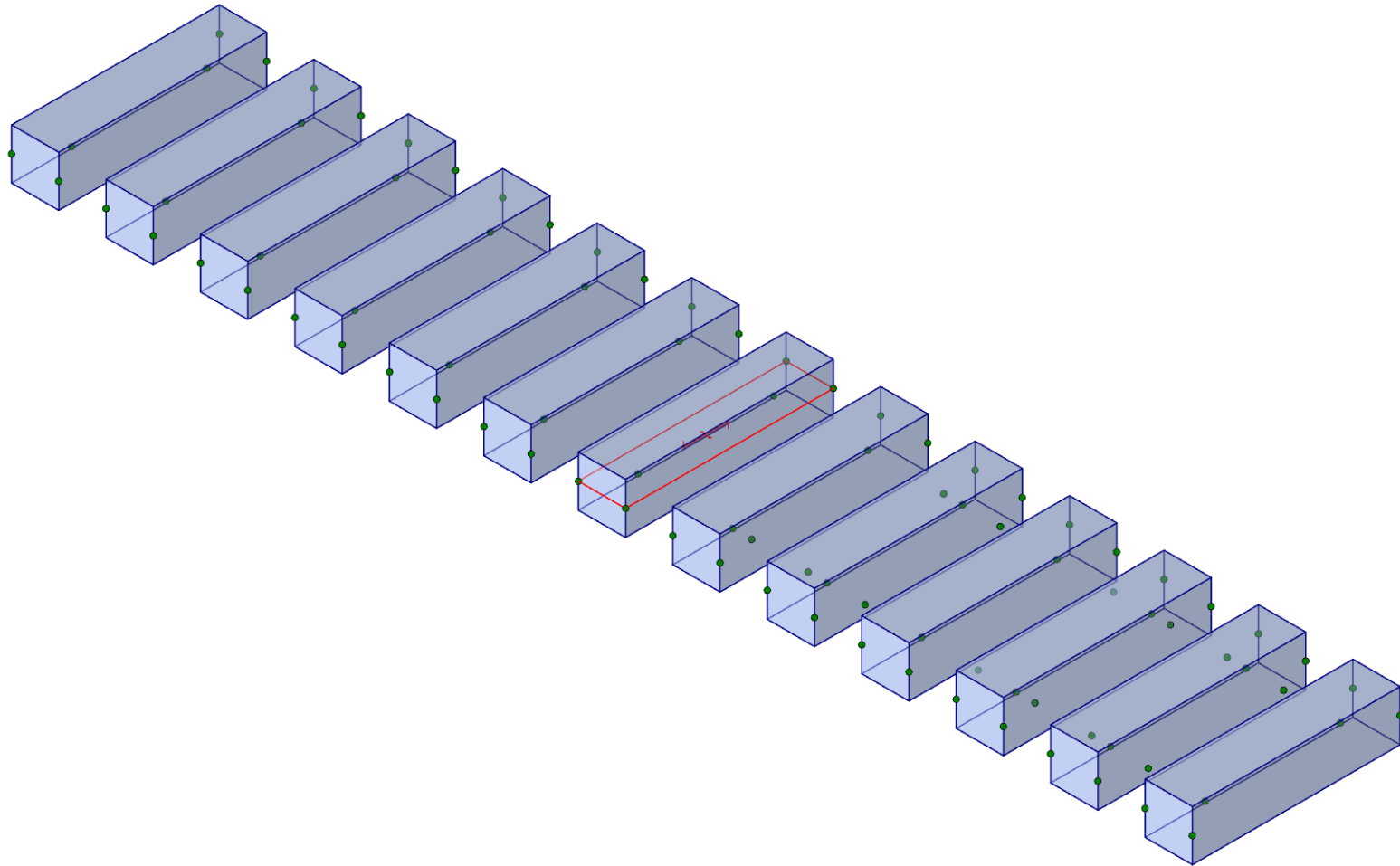

Vector Structural Engineering  
CJT  
U2716.0385.241

Ground Mount

SK-1  
Mar 20, 2024  
Sunturf A16 - LF - 35deg.r3d

**Concrete Properties**

Label	E [ksi]	G [ksi]	Nu	Therm. Coeff. [1e <sup>5</sup> F <sup>-1</sup> ]	Density [lb/ft <sup>3</sup> ]	f <sub>c</sub> [psi]	Lambda	Flex Steel [psi]	Shear Steel [psi]
1 Conc3000NW	3156	1372	0.15	0.6	145	3000	1	60000	60000
2 Conc3500NW	3409	1482	0.15	0.6	145	3500	1	60000	60000
3 Conc4000NW	3644	1584	0.15	0.6	145	4000	1	60000	60000
4 Conc3000LW	2085	907	0.15	0.6	109.999	3000	0.75	60000	60000
5 Conc3500LW	2252	979	0.15	0.6	109.999	3500	0.75	60000	60000
6 Conc4000LW	2408	1047	0.15	0.6	109.999	4000	0.75	60000	60000
7 Conc2500NW	3156	1372	0.15	0.6	145	2500	1	60000	60000

**Design Rules - Mat Slab**

Label	Max Bending Chk	Max Shear Chk	Top Bar	Bottom Bar	Min Top Bar Spacing [in]	Max Top Bar Spacing [in]	Min Bot Bar Spacing [in]	Max Bot Bar Spacing [in]	Spacing Increment [in]	Top Cover [in]	Bottom Cover [in]	Side Cover [in]	Rebar Options
1 Typical	1	1	#5	#5	3	12	3	12	1	3	3	0	Optimize

**Soil Definitions**

Label	Layers	Subgrade Modulus [lb/ft <sup>3</sup> ]	Allowable Bearing [psf]	Default
1 Default	Single	1e+5	1499.99999	Yes

**Slab**

Label	Thickness [in]	Material	Local Axis Angle [deg]	Analysis Offset [in]	Passive Pressure [psf]	Soil Overburden [psf]	Icr Factor
1 S10	32	Conc2500NW	0	0	0	0	0.25
2 S2	32	Conc2500NW	0	0	0	0	0.25
3 S7	32	Conc2500NW	0	0	0	0	0.25
4 S4	32	Conc2500NW	0	0	0	0	0.25
5 S5	32	Conc2500NW	0	0	0	0	0.25
6 S6	32	Conc2500NW	0	0	0	0	0.25
7 S8	32	Conc2500NW	0	0	0	0	0.25
8 S9	32	Conc2500NW	0	0	0	0	0.25
9 S11	32	Conc2500NW	0	0	0	0	0.25
10 S12	32	Conc2500NW	0	0	0	0	0.25
11 S13	32	Conc2500NW	0	0	0	0	0.25
12 S14	32	Conc2500NW	0	0	0	0	0.25
13 S15	32	Conc2500NW	0	0	0	0	0.25

**Load Category**

Category	Node Loads
1 DL	28
2 RLL	46
3 WLZ	54
4 OL1	74
5 OL2	74
6 OL3	74
7 OL4	60

**Load Combination**

Label	Solve	Service	SF	Category	Factor	Category	Factor	Category	Factor
1 ASD Loads									
2 1.0 D	Yes	Yes	1.5	DL	1				
3 1.0 D + 1.0 S	Yes	Yes	1.5	DL	1	RLL	1		
4 1.0 D + 0.6 W1	Yes	Yes	1.5	DL	1	RLL		OL1	0.6

**Load Combination (Continued)**

	Label	Solve	Service	SF	Category	Factor	Category	Factor	Category	Factor
5	1.0 D + 0.6 W2	Yes	Yes	1.5	DL	1	RLL		OL2	0.6
6	1.0 D + 0.6 W3	Yes	Yes	1.5	DL	1	RLL		OL3	0.6
7	1.0 D + 0.6 W4	Yes	Yes	1.5	DL	1	RLL		OL4	0.6
8	1.0 D + 0.45 W1 + 0.75 S	Yes	Yes	1.5	DL	1	RLL	0.75	OL1	0.45
9	1.0 D + 0.45 W2 + 0.75 S	Yes	Yes	1.5	DL	1	RLL	0.75	OL2	0.45
10	1.0 D + 0.45 W3 + 0.75 S	Yes	Yes	1.5	DL	1	RLL	0.75	OL3	0.45
11	1.0 D + 0.45 W4 + 0.75 S	Yes	Yes	1.5	DL	1	RLL	0.75	OL4	0.45
12	0.6 D + 0.6 W1	Yes	Yes		DL	0.6	RLL		OL1	0.6
13	0.6 D + 0.6 W2	Yes	Yes		DL	0.6	RLL		OL2	0.6
14	0.6 D + 0.6 W3	Yes	Yes		DL	0.6	RLL		OL3	0.6
15	0.6 D + 0.6 W4	Yes	Yes		DL	0.6	RLL		OL4	0.6
16										
17	LRFD Loads									
18	1.4 D	Yes			DL	1.4	RLL			
19	1.2 D + 1.6 S + 0.5 W1	Yes			DL	1.2	RLL	1.6	OL1	0.5
20	1.2 D + 1.6 S + 0.5 W2	Yes			DL	1.2	RLL	1.6	OL2	0.5
21	1.2 D + 1.6 S + 0.5 W3	Yes			DL	1.2	RLL	1.6	OL3	0.5
22	1.2 D + 1.6 S + 0.5 W4	Yes			DL	1.2	RLL	1.6	OL4	0.5
23	1.2 D + 1.0 W1	Yes			DL	1.2	RLL		OL1	1
24	1.2 D + 1.0 W2	Yes			DL	1.2	RLL		OL2	1
25	1.2 D + 1.0 W3	Yes			DL	1.2	RLL		OL3	1
26	1.2 D + 1.0 W4	Yes			DL	1.2	RLL		OL4	1
27	0.9 D + 1.0 W1	Yes			DL	0.9	RLL		OL1	1
28	0.9 D + 1.0 W2	Yes			DL	0.9	RLL		OL2	1
29	0.9 D + 1.0 W3	Yes			DL	0.9	RLL		OL3	1
30	0.9 D + 1.0 W4	Yes			DL	0.9	RLL		OL4	1

**Design Strips**

	Label	Rebar Angle from Plan Horizontal (deg)	No. of Design Cuts	Design Rule
1	DS1	0	50	Typical
2	DS2	90	50	Typical

**Strip Reinforcing**

	Label	UC Top	LC Top	Top Bars	Gov Design Cut	UC Top	UC Bot	LC Bot	Bot Bars	Gov Design Cut	UC Bot	UC Shear	LC Gov Design Cut	UC Shear
1	DS1	0.011	21	#5@5in	DS1-X26	0.007	28	#5@5in	DS1-X26	0.062	21	DS1-X15		
2	DS2	0.001	27	#5@5in	DS2-X25	0.002	21	#5@5in	DS2-X26	0.012	21	DS2-X50		

**Slab Soil Pressures**

	LC	Label	UC	Soil Pressure[psf]	Allowable Bearing[psf]	Node
1	2	S10	0.268	402.526	1500	N62
2	2	S2	0.268	402.526	1500	N48
3	2	S7	0.267	399.891	1500	N72
4	2	S4	0.266	399.112	1500	N55
5	2	S5	0.267	400.293	1500	N65
6	2	S6	0.267	399.825	1500	N69
7	2	S8	0.267	399.915	1500	N77
8	2	S9	0.267	399.888	1500	N82
9	2	S11	0.267	399.888	1500	N86
10	2	S12	0.267	399.915	1500	N89
11	2	S13	0.267	399.825	1500	N93
12	2	S14	0.267	400.293	1500	N97
13	2	S15	0.266	399.112	1500	N100

**Slab Soil Pressures (Continued)**

	LC	Label	UC	Soil Pressure[psf]	Allowable Bearing[psf]	Node
14	3	S10	0.352	527.852	1500	N62
15	3	S2	0.352	527.862	1500	N48
16	3	S7	0.342	513.357	1500	N72
17	3	S4	0.351	526.509	1500	N55
18	3	S5	0.346	518.399	1500	N65
19	3	S6	0.342	512.544	1500	N69
20	3	S8	0.342	513.681	1500	N77
21	3	S9	0.342	513.334	1500	N82
22	3	S11	0.342	513.334	1500	N86
23	3	S12	0.342	513.681	1500	N89
24	3	S13	0.342	512.544	1500	N93
25	3	S14	0.346	518.399	1500	N97
26	3	S15	0.351	526.501	1500	N100
27	4	S10	0.333	499.87	1500	N64
28	4	S2	0.333	499.868	1500	N47
29	4	S7	0.341	511.626	1500	N71
30	4	S4	0.337	505.918	1500	N55
31	4	S5	0.342	512.531	1500	N60
32	4	S6	0.341	511.127	1500	N67
33	4	S8	0.341	511.64	1500	N76
34	4	S9	0.341	510.978	1500	N79
35	4	S11	0.341	510.977	1500	N84
36	4	S12	0.341	511.637	1500	N88
37	4	S13	0.341	511.127	1500	N92
38	4	S14	0.342	512.533	1500	N96
39	4	S15	0.337	505.929	1500	N100
40	5	S10	0.372	557.524	1500	N64
41	5	S2	0.372	557.522	1500	N47
42	5	S7	0.384	576.013	1500	N71
43	5	S4	0.38	570.08	1500	N55
44	5	S5	0.385	576.879	1500	N60
45	5	S6	0.384	575.66	1500	N67
46	5	S8	0.384	576.171	1500	N76
47	5	S9	0.384	575.29	1500	N80
48	5	S11	0.384	575.289	1500	N84
49	5	S12	0.384	576.17	1500	N88
50	5	S13	0.384	575.661	1500	N92
51	5	S14	0.385	576.881	1500	N96
52	5	S15	0.38	570.089	1500	N100
53	6	S10	0.459	688.203	1500	N62
54	6	S2	0.459	688.202	1500	N48
55	6	S7	0.466	699.164	1500	N72
56	6	S4	0.445	668.106	1500	N57
57	6	S5	0.469	704.201	1500	N65
58	6	S6	0.465	697.731	1500	N69
59	6	S8	0.466	699.48	1500	N77
60	6	S9	0.466	698.364	1500	N82
61	6	S11	0.466	698.363	1500	N86
62	6	S12	0.466	699.478	1500	N89
63	6	S13	0.465	697.731	1500	N93
64	6	S14	0.469	704.204	1500	N97
65	6	S15	0.445	668.119	1500	N101
66	7	S10	0.392	587.997	1500	N62
67	7	S2	0.392	587.997	1500	N48
68	7	S7	0.398	596.515	1500	N72

**Slab Soil Pressures (Continued)**

	LC	Label	UC	Soil Pressure[psf]	Allowable Bearing[psf]	Node
69	7	S4	0.384	576.684	1500	N57
70	7	S5	0.4	599.855	1500	N65
71	7	S6	0.397	595.505	1500	N69
72	7	S8	0.398	596.686	1500	N77
73	7	S9	0.397	596	1500	N82
74	7	S11	0.397	595.999	1500	N86
75	7	S12	0.398	596.684	1500	N89
76	7	S13	0.397	595.505	1500	N93
77	7	S14	0.4	599.858	1500	N97
78	7	S15	0.384	576.696	1500	N101
79	8	S10	0.359	539.222	1500	N64
80	8	S2	0.359	539.213	1500	N47
81	8	S7	0.379	568.203	1500	N71
82	8	S4	0.383	574.764	1500	N55
83	8	S5	0.378	567.56	1500	N60
84	8	S6	0.379	568.166	1500	N68
85	8	S8	0.379	568.371	1500	N76
86	8	S9	0.379	567.78	1500	N79
87	8	S11	0.379	567.78	1500	N83
88	8	S12	0.379	568.37	1500	N88
89	8	S13	0.379	568.166	1500	N92
90	8	S14	0.378	567.562	1500	N96
91	8	S15	0.383	574.767	1500	N100
92	9	S10	0.388	582.462	1500	N64
93	9	S2	0.388	582.454	1500	N47
94	9	S7	0.411	616.494	1500	N71
95	9	S4	0.415	622.885	1500	N55
96	9	S5	0.411	615.821	1500	N60
97	9	S6	0.411	616.566	1500	N68
98	9	S8	0.411	616.77	1500	N76
99	9	S9	0.411	616.014	1500	N79
100	9	S11	0.411	616.014	1500	N84
101	9	S12	0.411	616.769	1500	N88
102	9	S13	0.411	616.567	1500	N92
103	9	S14	0.411	615.823	1500	N96
104	9	S15	0.415	622.887	1500	N100
105	10	S10	0.474	710.778	1500	N62
106	10	S2	0.474	710.785	1500	N48
107	10	S7	0.473	709.445	1500	N72
108	10	S4	0.442	663.011	1500	N57
109	10	S5	0.478	716.804	1500	N65
110	10	S6	0.472	707.794	1500	N69
111	10	S8	0.473	709.913	1500	N77
112	10	S9	0.473	708.829	1500	N82
113	10	S11	0.473	708.828	1500	N86
114	10	S12	0.473	709.912	1500	N89
115	10	S13	0.472	707.794	1500	N93
116	10	S14	0.478	716.806	1500	N97
117	10	S15	0.442	663.027	1500	N101
118	11	S10	0.424	635.624	1500	N62
119	11	S2	0.424	635.631	1500	N48
120	11	S7	0.422	632.459	1500	N72
121	11	S4	0.396	594.445	1500	N57
122	11	S5	0.426	638.545	1500	N65
123	11	S6	0.421	631.124	1500	N69



**Slab Soil Pressures (Continued)**

	LC	Label	UC	Soil Pressure[psf]	Allowable Bearing[psf]	Node
124	11	S8	0.422	632.817	1500	N77
125	11	S9	0.421	632.057	1500	N82
126	11	S11	0.421	632.056	1500	N86
127	11	S12	0.422	632.816	1500	N89
128	11	S13	0.421	631.125	1500	N93
129	11	S14	0.426	638.546	1500	N97
130	11	S15	0.396	594.459	1500	N101
131	12	S10	0.228	342.19	1500	N64
132	12	S2	0.228	342.188	1500	N47
133	12	S7	0.236	354.425	1500	N71
134	12	S4	0.231	346.273	1500	N55
135	12	S5	0.237	355.836	1500	N60
136	12	S6	0.236	353.776	1500	N67
137	12	S8	0.236	354.46	1500	N75
138	12	S9	0.236	353.692	1500	N80
139	12	S11	0.236	353.692	1500	N84
140	12	S12	0.236	354.458	1500	N88
141	12	S13	0.236	353.776	1500	N91
142	12	S14	0.237	355.838	1500	N96
143	12	S15	0.231	346.284	1500	N100
144	13	S10	0.272	407.439	1500	N64
145	13	S2	0.272	407.437	1500	N47
146	13	S7	0.286	429.666	1500	N71
147	13	S4	0.276	413.902	1500	N55
148	13	S5	0.288	432.459	1500	N60
149	13	S6	0.286	428.774	1500	N67
150	13	S8	0.287	429.951	1500	N75
151	13	S9	0.286	428.619	1500	N80
152	13	S11	0.286	428.619	1500	N84
153	13	S12	0.287	429.949	1500	N88
154	13	S13	0.286	428.774	1500	N92
155	13	S14	0.288	432.462	1500	N96
156	13	S15	0.276	413.913	1500	N100
157	14	S10	0.351	527.192	1500	N62
158	14	S2	0.351	527.191	1500	N48
159	14	S7	0.359	539.208	1500	N72
160	14	S4	0.339	509.194	1500	N57
161	14	S5	0.363	544.084	1500	N65
162	14	S6	0.359	537.801	1500	N69
163	14	S8	0.36	539.514	1500	N77
164	14	S9	0.359	538.408	1500	N82
165	14	S11	0.359	538.407	1500	N86
166	14	S12	0.36	539.512	1500	N89
167	14	S13	0.359	537.801	1500	N93
168	14	S14	0.363	544.087	1500	N97
169	14	S15	0.339	509.207	1500	N101
170	15	S10	0.285	426.987	1500	N62
171	15	S2	0.285	426.986	1500	N48
172	15	S7	0.291	436.559	1500	N72
173	15	S4	0.279	417.772	1500	N57
174	15	S5	0.293	439.738	1500	N65
175	15	S6	0.29	435.575	1500	N69
176	15	S8	0.291	436.72	1500	N77
177	15	S9	0.291	436.045	1500	N82
178	15	S11	0.291	436.044	1500	N86

**Slab Soil Pressures (Continued)**

	LC	Label	UC	Soil Pressure[psf]	Allowable Bearing[psf]	Node
179	15	S12	0.291	436.718	1500	N89
180	15	S13	0.29	435.575	1500	N93
181	15	S14	0.293	439.741	1500	N97
182	15	S15	0.279	417.783	1500	N101

**Slab Stability - Overturning**

	LC	Slab	Angle[deg]	Mo-xx[lb-ft]	Ms-xx[lb-ft]	Mo-zz[lb-ft]	Ms-zz[lb-ft]	Ms-xx/Mo-xx	Ms-zz/Mo-zz
1	2	S10	0	0	60128.135	0	13674.121	9.99+	9.99+
2	2	S2	0	0	60128.106	0	13743.122	9.99+	9.99+
3	2	S7	0	0	60277.691	0	13710.991	9.99+	9.99+
4	2	S4	0	0	60268.505	0	13686.678	9.99+	9.99+
5	2	S5	0	0	60283.055	0	13715.404	9.99+	9.99+
6	2	S6	0	0	60278.024	0	13710.473	9.99+	9.99+
7	2	S8	0	0	60280.661	0	13711.71	9.99+	9.99+
8	2	S9	0	0	60278.347	0	13711.083	9.99+	9.99+
9	2	S11	0	0	60278.348	0	13711.082	9.99+	9.99+
10	2	S12	0	0	60280.669	0	13711.712	9.99+	9.99+
11	2	S13	0	0	60278.028	0	13710.474	9.99+	9.99+
12	2	S14	0	0	60283.056	0	13715.404	9.99+	9.99+
13	2	S15	0	0	60268.481	0	13686.679	9.99+	9.99+
14	3	S10	0	0	75183.952	0	16957.426	9.99+	9.99+
15	3	S2	0	0	75183.497	0	17747.156	9.99+	9.99+
16	3	S7	0	0	77369.39	0	17596.217	9.99+	9.99+
17	3	S4	0	0	77283.656	0	17302.212	9.99+	9.99+
18	3	S5	0	0	77443.694	0	17650.753	9.99+	9.99+
19	3	S6	0	0	77370.646	0	17594.218	9.99+	9.99+
20	3	S8	0	0	77407.881	0	17610.876	9.99+	9.99+
21	3	S9	0	0	77377.23	0	17603.1	9.99+	9.99+
22	3	S11	0	0	77377.243	0	17591.594	9.99+	9.99+
23	3	S12	0	0	77407.985	0	17600.268	9.99+	9.99+
24	3	S13	0	0	77370.697	0	17586.593	9.99+	9.99+
25	3	S14	0	0	77443.713	0	17650.758	9.99+	9.99+
26	3	S15	0	0	77283.301	0	17295.983	9.99+	9.99+
27	4	S10	0	22658.884	60507.738	2702.093	13743.122	2.67	5.086
28	4	S2	0	22658.776	60507.773	2702.092	13743.122	2.67	5.086
29	4	S7	0	23925.053	60379.026	2443.081	13710.991	2.524	5.612
30	4	S4	0	21881.446	60174.265	2156.729	13686.678	2.75	6.346
31	4	S5	0	24253.508	60412.497	2494.977	13715.404	2.491	5.497
32	4	S6	0	23829.29	60374.138	2433.073	13710.473	2.534	5.635
33	4	S8	0	23947.368	60382.386	2449.341	13711.71	2.521	5.598
34	4	S9	0	23878.936	60379.182	2442.771	13711.083	2.529	5.613
35	4	S11	0	23878.894	60379.178	2442.766	13711.082	2.529	5.613
36	4	S12	0	23947.279	60382.393	2449.355	13711.712	2.521	5.598
37	4	S13	0	23829.327	60374.143	2433.079	13710.474	2.534	5.635
38	4	S14	0	24253.69	60412.499	2494.987	13715.404	2.491	5.497
39	4	S15	0	21882.105	60174.292	2156.727	13686.679	2.75	6.346
40	5	S10	0	23470.287	60507.738	2481.887	13743.122	2.578	5.537
41	5	S2	0	23470.175	60507.773	2481.876	13743.122	2.578	5.537
42	5	S7	0	24250.859	60379.026	2039.264	13710.991	2.49	6.723
43	5	S4	0	21646.337	60174.265	1669.876	13686.678	2.78	8.196
44	5	S5	0	24654.867	60412.497	2107.797	13715.404	2.45	6.507
45	5	S6	0	24133.59	60374.138	2026.361	13710.473	2.502	6.766
46	5	S8	0	24274.158	60382.386	2047.699	13711.71	2.488	6.696
47	5	S9	0	24194.316	60379.182	2041.086	13711.083	2.496	6.718
48	5	S11	0	24194.259	60379.178	2041.079	13711.082	2.496	6.718

**Slab Stability - Overturning (Continued)**

	LC	Slab	Angle[deg]	Mo-xx[lb-ft]	Ms-xx[lb-ft]	Mo-zz[lb-ft]	Ms-zz[lb-ft]	Ms-xx/Mo-xx	Ms-zz/Mo-zz
49	5	S12	0	24274.092	60382.393	2047.712	13711.712	2.488	6.696
50	5	S13	0	24133.639	60374.143	2026.367	13710.474	2.502	6.766
51	5	S14	0	24655.056	60412.499	2107.808	13715.404	2.45	6.507
52	5	S15	0	21646.929	60174.292	1669.875	13686.679	2.78	8.196
53	6	S10	0	1822.701	60128.135	0	16117.672	9.99+	9.99+
54	6	S2	0	1822.584	60128.106	0	16897.997	9.99+	9.99+
55	6	S7	0	2832.444	60277.691	0	16563.453	9.99+	9.99+
56	6	S4	0	3520.636	60268.505	0	16204.805	9.99+	9.99+
57	6	S5	0	2701.982	60283.055	0	16624.083	9.99+	9.99+
58	6	S6	0	2832.687	60278.024	0	16549.155	9.99+	9.99+
59	6	S8	0	2813.977	60280.661	0	16566.982	9.99+	9.99+
60	6	S9	0	2783.523	60278.347	0	16562.789	9.99+	9.99+
61	6	S11	0	2783.529	60278.348	0	16563.177	9.99+	9.99+
62	6	S12	0	2813.738	60280.669	0	16571.499	9.99+	9.99+
63	6	S13	0	2832.659	60278.028	0	16551.259	9.99+	9.99+
64	6	S14	0	2702.11	60283.056	0	16628.469	9.99+	9.99+
65	6	S15	0	3521.456	60268.481	0	16174.777	9.99+	9.99+
66	7	S10	0	0	61599.872	0	15872.691	9.99+	9.99+
67	7	S2	0	0	61599.928	0	16394.12	9.99+	9.99+
68	7	S7	0	0	61520.35	0	16289.5	9.99+	9.99+
69	7	S4	0	0	61188.144	0	16078.792	9.99+	9.99+
70	7	S5	0	0	61588.366	0	16327.316	9.99+	9.99+
71	7	S6	0	0	61539.027	0	16283.351	9.99+	9.99+
72	7	S8	0	0	61545.644	0	16294.961	9.99+	9.99+
73	7	S9	0	0	61555.959	0	16289.856	9.99+	9.99+
74	7	S11	0	0	61555.963	0	16289.853	9.99+	9.99+
75	7	S12	0	0	61545.868	0	16294.975	9.99+	9.99+
76	7	S13	0	0	61539.065	0	16283.358	9.99+	9.99+
77	7	S14	0	0	61588.253	0	16327.322	9.99+	9.99+
78	7	S15	0	0	61187.417	0	16069.435	9.99+	9.99+
79	8	S10	0	16994.163	73264.055	2026.57	16746.14	4.311	8.263
80	8	S2	0	16994.082	73264.466	2026.569	16746.147	4.311	8.263
81	8	S7	0	17943.789	73202.747	1832.311	16624.91	4.08	9.073
82	8	S4	0	16411.084	71254.864	1617.547	16398.329	4.342	9.99+
83	8	S5	0	18190.131	73515.321	1871.233	16666.915	4.041	8.907
84	8	S6	0	17871.967	73162.197	1824.805	16617.556	4.094	9.106
85	8	S8	0	17960.526	73236.395	1837.006	16628.114	4.078	9.052
86	8	S9	0	17909.202	73204.384	1832.078	16621.471	4.088	9.072
87	8	S11	0	17909.171	73204.343	1832.075	16621.466	4.088	9.072
88	8	S12	0	17960.459	73236.459	1837.016	16628.129	4.078	9.052
89	8	S13	0	17871.995	73162.239	1824.81	16617.563	4.094	9.106
90	8	S14	0	18190.268	73515.34	1871.24	16666.919	4.041	8.907
91	8	S15	0	16411.579	71255.167	1617.545	16398.335	4.342	9.99+
92	9	S10	0	17602.715	73264.055	1861.415	16746.14	4.162	8.996
93	9	S2	0	17602.631	73264.466	1861.407	16746.147	4.162	8.997
94	9	S7	0	18188.144	73202.747	1529.448	16624.91	4.025	9.99+
95	9	S4	0	16234.753	71254.864	1252.407	16398.329	4.389	9.99+
96	9	S5	0	18491.15	73515.321	1580.847	16666.915	3.976	9.99+
97	9	S6	0	18100.192	73162.197	1519.771	16617.556	4.042	9.99+
98	9	S8	0	18205.618	73236.395	1535.774	16628.114	4.023	9.99+
99	9	S9	0	18145.737	73204.384	1530.815	16621.471	4.034	9.99+
100	9	S11	0	18145.694	73204.343	1530.809	16621.466	4.034	9.99+
101	9	S12	0	18205.569	73236.459	1535.784	16628.129	4.023	9.99+
102	9	S13	0	18100.23	73162.239	1519.775	16617.563	4.042	9.99+
103	9	S14	0	18491.292	73515.34	1580.856	16666.919	3.976	9.99+

**Slab Stability - Overturning (Continued)**

	LC	Slab	Angle[deg]	Mo-xx[lb-ft]	Ms-xx[lb-ft]	Mo-zz[lb-ft]	Ms-zz[lb-ft]	Ms-xx/Mo-xx	Ms-zz/Mo-zz
104	9	S15	0	16235.197	71255.167	1252.406	16398.335	4.389	9.99+
105	10	S10	0	1367.026	71419.997	0	17969.263	9.99+	9.99+
106	10	S2	0	1366.938	71419.649	0	19112.304	9.99+	9.99+
107	10	S7	0	2124.333	73096.465	0	18764.257	9.99+	9.99+
108	10	S4	0	2640.477	73029.868	0	18286.924	9.99+	9.99+
109	10	S5	0	2026.487	73153.534	0	18848.425	9.99+	9.99+
110	10	S6	0	2124.515	73097.491	0	18752.293	9.99+	9.99+
111	10	S8	0	2110.483	73126.076	0	18777.539	9.99+	9.99+
112	10	S9	0	2087.642	73102.509	0	18768.875	9.99+	9.99+
113	10	S11	0	2087.647	73102.519	0	18760.537	9.99+	9.99+
114	10	S12	0	2110.303	73126.156	0	18772.969	9.99+	9.99+
115	10	S13	0	2124.495	73097.529	0	18748.152	9.99+	9.99+
116	10	S14	0	2026.582	73153.549	0	18851.718	9.99+	9.99+
117	10	S15	0	2641.092	73029.596	0	18259.731	9.99+	9.99+
118	11	S10	0	0	72523.8	0	17785.527	9.99+	9.99+
119	11	S2	0	0	72523.515	0	18734.396	9.99+	9.99+
120	11	S7	0	0	74028.459	0	18558.792	9.99+	9.99+
121	11	S4	0	0	73719.598	0	18192.414	9.99+	9.99+
122	11	S5	0	0	74132.518	0	18625.85	9.99+	9.99+
123	11	S6	0	0	74043.243	0	18552.94	9.99+	9.99+
124	11	S8	0	0	74074.813	0	18573.522	9.99+	9.99+
125	11	S9	0	0	74060.718	0	18564.175	9.99+	9.99+
126	11	S11	0	0	74060.731	0	18555.544	9.99+	9.99+
127	11	S12	0	0	74075.055	0	18565.577	9.99+	9.99+
128	11	S13	0	0	74043.307	0	18547.227	9.99+	9.99+
129	11	S14	0	0	74132.446	0	18625.858	9.99+	9.99+
130	11	S15	0	0	73718.798	0	18180.724	9.99+	9.99+
131	12	S10	0	22658.884	36304.643	2702.093	8245.873	1.602	3.052
132	12	S2	0	22658.776	36304.664	2702.092	8245.873	1.602	3.052
133	12	S7	0	23925.053	36227.416	2443.081	8226.594	1.514	3.367
134	12	S4	0	21881.446	36104.559	2156.729	8212.007	1.65	3.808
135	12	S5	0	24253.508	36247.498	2494.977	8229.242	1.495	3.298
136	12	S6	0	23829.29	36224.483	2433.073	8226.284	1.52	3.381
137	12	S8	0	23947.368	36229.432	2449.341	8227.026	1.513	3.359
138	12	S9	0	23878.936	36227.509	2442.771	8226.65	1.517	3.368
139	12	S11	0	23878.894	36227.507	2442.766	8226.649	1.517	3.368
140	12	S12	0	23947.279	36229.436	2449.355	8227.027	1.513	3.359
141	12	S13	0	23829.327	36224.486	2433.079	8226.284	1.52	3.381
142	12	S14	0	24253.69	36247.499	2494.987	8229.242	1.495	3.298
143	12	S15	0	21882.105	36104.575	2156.727	8212.007	1.65	3.808
144	13	S10	0	23470.287	36304.643	2481.887	8245.873	1.547	3.322
145	13	S2	0	23470.175	36304.664	2481.876	8245.873	1.547	3.322
146	13	S7	0	24250.859	36227.416	2039.264	8226.594	1.494	4.034
147	13	S4	0	21646.337	36104.559	1669.876	8212.007	1.668	4.918
148	13	S5	0	24654.867	36247.498	2107.797	8229.242	1.47	3.904
149	13	S6	0	24133.59	36224.483	2026.361	8226.284	1.501	4.06
150	13	S8	0	24274.158	36229.432	2047.699	8227.026	1.493	4.018
151	13	S9	0	24194.316	36227.509	2041.086	8226.65	1.497	4.031
152	13	S11	0	24194.259	36227.507	2041.079	8226.649	1.497	4.031
153	13	S12	0	24274.092	36229.436	2047.712	8227.027	1.493	4.018
154	13	S13	0	24133.639	36224.486	2026.367	8226.284	1.501	4.06
155	13	S14	0	24655.056	36247.499	2107.808	8229.242	1.47	3.904
156	13	S15	0	21646.929	36104.575	1669.875	8212.007	1.668	4.918
157	14	S10	0	1822.701	36076.881	0	10648.024	9.99+	9.99+
158	14	S2	0	1822.584	36076.864	0	11400.748	9.99+	9.99+

**Slab Stability - Overturning (Continued)**

	LC	Slab	Angle[deg]	Mo-xx[lb-ft]	Ms-xx[lb-ft]	Mo-zz[lb-ft]	Ms-zz[lb-ft]	Ms-xx/Mo-xx	Ms-zz/Mo-zz
159	14	S7	0	2832.444	36166.614	0	11079.057	9.99+	9.99+
160	14	S4	0	3520.636	36161.103	0	10730.134	9.99+	9.99+
161	14	S5	0	2701.982	36169.833	0	11137.921	9.99+	9.99+
162	14	S6	0	2832.687	36166.815	0	11064.966	9.99+	9.99+
163	14	S8	0	2813.977	36168.397	0	11082.298	9.99+	9.99+
164	14	S9	0	2783.523	36167.008	0	11078.356	9.99+	9.99+
165	14	S11	0	2783.529	36167.009	0	11078.744	9.99+	9.99+
166	14	S12	0	2813.738	36168.402	0	11086.814	9.99+	9.99+
167	14	S13	0	2832.659	36166.817	0	11067.069	9.99+	9.99+
168	14	S14	0	2702.11	36169.834	0	11142.308	9.99+	9.99+
169	14	S15	0	3521.456	36161.088	0	10700.105	9.99+	9.99+
170	15	S10	0	0	37548.618	0	10403.043	9.99+	9.99+
171	15	S2	0	0	37548.685	0	10896.871	9.99+	9.99+
172	15	S7	0	0	37409.273	0	10805.104	9.99+	9.99+
173	15	S4	0	0	37080.742	0	10604.12	9.99+	9.99+
174	15	S5	0	0	37475.144	0	10841.155	9.99+	9.99+
175	15	S6	0	0	37427.817	0	10799.162	9.99+	9.99+
176	15	S8	0	0	37433.379	0	10810.277	9.99+	9.99+
177	15	S9	0	0	37444.62	0	10805.422	9.99+	9.99+
178	15	S11	0	0	37444.624	0	10805.42	9.99+	9.99+
179	15	S12	0	0	37433.6	0	10810.291	9.99+	9.99+
180	15	S13	0	0	37427.854	0	10799.169	9.99+	9.99+
181	15	S14	0	0	37475.03	0	10841.16	9.99+	9.99+
182	15	S15	0	0	37080.025	0	10594.764	9.99+	9.99+

**Slab Stability - Sliding**

	LC	Slab	Angle[deg]	Va-xx[lb]	Vr-xx[lb]	Va-zz[lb]	Vr-zz[lb]	SR-xx	SR-zz
1	2	S10	0	12.938	3290.069	0	3290.069	9.99+	9.99+
2	2	S2	0	12.937	3290.069	0	3290.069	9.99+	9.99+
3	2	S7	0	0	3290.638	0	3290.638	9.99+	9.99+
4	2	S4	0	0	3284.803	0	3284.803	9.99+	9.99+
5	2	S5	0	0	3291.697	0	3291.697	9.99+	9.99+
6	2	S6	0	0	3290.514	0	3290.514	9.99+	9.99+
7	2	S8	0	0	3290.81	0	3290.81	9.99+	9.99+
8	2	S9	0	0	3290.66	0	3290.66	9.99+	9.99+
9	2	S11	0	0	3290.66	0	3290.66	9.99+	9.99+
10	2	S12	0	0	3290.811	0	3290.811	9.99+	9.99+
11	2	S13	0	0	3290.514	0	3290.514	9.99+	9.99+
12	2	S14	0	0	3291.697	0	3291.697	9.99+	9.99+
13	2	S15	0	0	3284.803	0	3284.803	9.99+	9.99+
14	3	S10	0	148.072	4164.549	0	4164.549	9.99+	9.99+
15	3	S2	0	148.073	4164.551	0	4164.551	9.99+	9.99+
16	3	S7	0	0	4223.092	0	4223.092	9.99+	9.99+
17	3	S4	0	1.168	4151.783	3.463	4151.783	9.99+	9.99+
18	3	S5	0	0	4236.181	4.457	4236.181	9.99+	9.99+
19	3	S6	0	1.431	4221.696	2.341	4221.696	9.99+	9.99+
20	3	S8	0	1.993	4225.335	0	4225.335	9.99+	9.99+
21	3	S9	0	2.156	4223.364	0	4223.364	9.99+	9.99+
22	3	S11	0	2.157	4223.363	0	4223.363	9.99+	9.99+
23	3	S12	0	1.993	4225.34	0	4225.34	9.99+	9.99+
24	3	S13	0	1.432	4221.699	2.339	4221.699	9.99+	9.99+
25	3	S14	0	0	4236.182	4.455	4236.182	9.99+	9.99+
26	3	S15	0	1.169	4151.784	3.459	4151.784	9.99+	9.99+
27	4	S10	0	101.294	2714.675	1170.524	2714.675	9.99+	2.319
28	4	S2	0	101.295	2714.676	1170.508	2714.676	9.99+	2.319

**Slab Stability - Sliding (Continued)**

	LC	Slab	Angle[deg]	Va-xx[lb]	Vr-xx[lb]	Va-zz[lb]	Vr-zz[lb]	SR-xx	SR-zz
29	4	S7	0	0	2704.298	1371.089	2704.298	9.99+	1.972
30	4	S4	0	4.821	2770.273	1400.037	2770.273	9.99+	1.979
31	4	S5	0	0.703	2693.352	1363.301	2693.352	9.99+	1.976
32	4	S6	0	0.336	2706.791	1369.627	2706.791	9.99+	1.976
33	4	S8	0	0.722	2703.431	1369.927	2703.431	9.99+	1.973
34	4	S9	0	0.063	2704.435	1367.506	2704.435	9.99+	1.978
35	4	S11	0	0.064	2704.437	1367.507	2704.437	9.99+	1.978
36	4	S12	0	0.723	2703.428	1369.912	2703.428	9.99+	1.973
37	4	S13	0	0.336	2706.79	1369.626	2706.79	9.99+	1.976
38	4	S14	0	0.703	2693.35	1363.312	2693.35	9.99+	1.976
39	4	S15	0	4.822	2770.274	1400.073	2770.274	9.99+	1.979
40	5	S10	0	122.756	2781.26	976.402	2781.26	9.99+	2.848
41	5	S2	0	122.752	2781.261	976.387	2781.261	9.99+	2.849
42	5	S7	0	0	2801.214	1144.658	2801.214	9.99+	2.447
43	5	S4	0	7.778	2889.01	1168.845	2889.01	9.99+	2.472
44	5	S5	0	1.858	2787.014	1135.953	2787.014	9.99+	2.453
45	5	S6	0	1.056	2804.863	1142.968	2804.863	9.99+	2.454
46	5	S8	0	1.878	2800.564	1143.09	2800.564	9.99+	2.45
47	5	S9	0	1.158	2801.54	1140.365	2801.54	9.99+	2.457
48	5	S11	0	1.158	2801.542	1140.366	2801.542	9.99+	2.457
49	5	S12	0	1.878	2800.562	1143.077	2800.562	9.99+	2.45
50	5	S13	0	1.056	2804.862	1142.967	2804.862	9.99+	2.454
51	5	S14	0	1.858	2787.012	1135.962	2787.012	9.99+	2.453
52	5	S15	0	7.779	2889.011	1168.879	2889.011	9.99+	2.472
53	6	S10	0	146.311	3961.88	1366.665	3961.88	9.99+	2.899
54	6	S2	0	146.311	3961.88	1366.647	3961.88	9.99+	2.899
55	6	S7	0	0	3975.229	1600.839	3975.229	9.99+	2.483
56	6	S4	0	5.629	3885.551	1634.638	3885.551	9.99+	2.377
57	6	S5	0	0.82	3990.305	1591.746	3990.305	9.99+	2.507
58	6	S6	0	0.393	3972.049	1599.132	3972.049	9.99+	2.484
59	6	S8	0	0.844	3976.616	1599.482	3976.616	9.99+	2.486
60	6	S9	0	0.074	3975.117	1596.655	3975.117	9.99+	2.49
61	6	S11	0	0.074	3975.115	1596.657	3975.115	9.99+	2.49
62	6	S12	0	0.844	3976.62	1599.465	3976.62	9.99+	2.486
63	6	S13	0	0.393	3972.051	1599.131	3972.051	9.99+	2.484
64	6	S14	0	0.821	3990.307	1591.759	3990.307	9.99+	2.507
65	6	S15	0	5.63	3885.55	1634.68	3885.55	9.99+	2.377
66	7	S10	0	97.768	3872.018	1235.983	3872.018	9.99+	3.133
67	7	S2	0	97.768	3872.017	1235.968	3872.017	9.99+	3.133
68	7	S7	0	0	3909.48	1446.918	3909.48	9.99+	2.702
69	7	S4	0	1.753	3857.788	1477.45	3857.788	9.99+	2.611
70	7	S5	0	0	3918.556	1440.658	3918.556	9.99+	2.72
71	7	S6	0	0	3908.004	1445.793	3908.004	9.99+	2.703
72	7	S8	0	0	3910.791	1446.223	3910.791	9.99+	2.704
73	7	S9	0	0	3909.565	1444.293	3909.565	9.99+	2.707
74	7	S11	0	0	3909.565	1444.294	3909.565	9.99+	2.707
75	7	S12	0	0	3910.794	1446.208	3910.794	9.99+	2.704
76	7	S13	0	0	3908.006	1445.791	3908.006	9.99+	2.703
77	7	S14	0	0	3918.557	1440.669	3918.557	9.99+	2.72
78	7	S15	0	1.754	3857.787	1477.484	3857.787	9.99+	2.611
79	8	S10	0	28.615	3514.383	877.893	3514.383	9.99+	4.003
80	8	S2	0	28.615	3514.385	877.881	3514.385	9.99+	4.003
81	8	S7	0	0	3550.224	1028.316	3550.224	9.99+	3.452
82	8	S4	0	2.74	3549.141	1047.43	3549.141	9.99+	3.388
83	8	S5	0	0.527	3551.301	1025.819	3551.301	9.99+	3.462

**Slab Stability - Sliding (Continued)**

	LC	Slab	Angle[deg]	Va-xx[lb]	Vr-xx[lb]	Va-zz[lb]	Vr-zz[lb]	SR-xx	SR-zz
84	8	S6	0	1.326	3551.109	1025.465	3551.109	9.99+	3.463
85	8	S8	0	2.036	3551.169	1027.445	3551.169	9.99+	3.456
86	8	S9	0	1.664	3550.52	1025.629	3550.52	9.99+	3.462
87	8	S11	0	1.665	3550.52	1025.63	3550.52	9.99+	3.462
88	8	S12	0	2.037	3551.171	1027.434	3551.171	9.99+	3.456
89	8	S13	0	1.327	3551.11	1025.465	3551.11	9.99+	3.463
90	8	S14	0	0.527	3551.3	1025.826	3551.3	9.99+	3.462
91	8	S15	0	2.739	3549.143	1047.461	3549.143	9.99+	3.388
92	9	S10	0	12.519	3564.322	732.302	3564.322	9.99+	4.867
93	9	S2	0	12.522	3564.324	732.29	3564.324	9.99+	4.867
94	9	S7	0	0	3622.911	858.494	3622.911	9.99+	4.22
95	9	S4	0	4.957	3638.194	874.036	3638.194	9.99+	4.163
96	9	S5	0	1.393	3621.548	855.308	3621.548	9.99+	4.234
97	9	S6	0	1.866	3624.663	855.47	3624.663	9.99+	4.237
98	9	S8	0	2.903	3624.019	857.318	3624.019	9.99+	4.227
99	9	S9	0	2.485	3623.348	855.274	3623.348	9.99+	4.236
100	9	S11	0	2.486	3623.349	855.275	3623.349	9.99+	4.236
101	9	S12	0	2.903	3624.021	857.308	3624.021	9.99+	4.227
102	9	S13	0	1.866	3624.664	855.471	3624.664	9.99+	4.237
103	9	S14	0	1.393	3621.547	855.313	3621.547	9.99+	4.234
104	9	S15	0	4.957	3638.195	874.065	3638.195	9.99+	4.162
105	10	S10	0	214.319	4449.787	1024.999	4449.787	9.99+	4.341
106	10	S2	0	214.319	4449.789	1024.985	4449.789	9.99+	4.341
107	10	S7	0	0	4503.422	1200.629	4503.422	9.99+	3.751
108	10	S4	0	5.098	4385.599	1228.575	4385.599	9.99+	3.57
109	10	S5	0	0.615	4524.016	1190.467	4524.016	9.99+	3.8
110	10	S6	0	0.779	4500.052	1201.105	4500.052	9.99+	3.747
111	10	S8	0	0.862	4506.058	1199.612	4506.058	9.99+	3.756
112	10	S9	0	1.562	4503.531	1197.491	4503.531	9.99+	3.761
113	10	S11	0	1.562	4503.529	1197.493	4503.529	9.99+	3.761
114	10	S12	0	0.862	4506.064	1199.599	4506.064	9.99+	3.756
115	10	S13	0	0.78	4500.056	1201.102	4500.056	9.99+	3.747
116	10	S14	0	0.616	4524.018	1190.478	4524.018	9.99+	3.8
117	10	S15	0	5.1	4385.599	1228.604	4385.599	9.99+	3.57
118	11	S10	0	177.912	4382.39	926.987	4382.39	9.99+	4.728
119	11	S2	0	177.912	4382.391	926.976	4382.391	9.99+	4.728
120	11	S7	0	0	4454.11	1085.188	4454.11	9.99+	4.104
121	11	S4	0	2.191	4364.777	1110.684	4364.777	9.99+	3.93
122	11	S5	0	0	4470.204	1077.15	4470.204	9.99+	4.15
123	11	S6	0	1.074	4452.019	1086.101	4452.019	9.99+	4.099
124	11	S8	0	1.494	4456.689	1084.667	4456.689	9.99+	4.109
125	11	S9	0	1.617	4454.367	1083.22	4454.367	9.99+	4.112
126	11	S11	0	1.618	4454.366	1083.221	4454.366	9.99+	4.112
127	11	S12	0	1.495	4456.695	1084.656	4456.695	9.99+	4.109
128	11	S13	0	1.074	4452.022	1086.098	4452.022	9.99+	4.099
129	11	S14	0	0	4470.206	1077.16	4470.206	9.99+	4.15
130	11	S15	0	2.192	4364.777	1110.707	4364.777	9.99+	3.93
131	12	S10	0	106.469	1398.648	1170.524	1398.648	9.99+	1.195
132	12	S2	0	106.47	1398.648	1170.508	1398.648	9.99+	1.195
133	12	S7	0	0	1388.043	1371.089	1388.043	9.99+	1.012
134	12	S4	0	4.821	1456.352	1400.037	1456.352	9.99+	1.04
135	12	S5	0	0.703	1376.673	1363.301	1376.673	9.99+	1.01
136	12	S6	0	0.336	1390.586	1369.627	1390.586	9.99+	1.015
137	12	S8	0	0.722	1387.107	1369.927	1387.107	9.99+	1.013
138	12	S9	0	0.063	1388.171	1367.506	1388.171	9.99+	1.015

**Slab Stability - Sliding (Continued)**

	LC	Slab	Angle[deg]	Va-xx[lb]	Vr-xx[lb]	Va-zz[lb]	Vr-zz[lb]	SR-xx	SR-zz
139	12	S11	0	0.064	1388.173	1367.507	1388.173	9.99+	1.015
140	12	S12	0	0.723	1387.104	1369.912	1387.104	9.99+	1.013
141	12	S13	0	0.336	1390.584	1369.626	1390.584	9.99+	1.015
142	12	S14	0	0.703	1376.671	1363.312	1376.671	9.99+	1.01
143	12	S15	0	4.822	1456.353	1400.073	1456.353	9.99+	1.04
144	13	S10	0	127.931	1465.233	976.402	1465.233	9.99+	1.501
145	13	S2	0	127.927	1465.233	976.387	1465.233	9.99+	1.501
146	13	S7	0	0	1484.959	1144.658	1484.959	9.99+	1.297
147	13	S4	0	7.778	1575.089	1168.845	1575.089	9.99+	1.348
148	13	S5	0	1.858	1470.336	1135.953	1470.336	9.99+	1.294
149	13	S6	0	1.056	1488.657	1142.968	1488.657	9.99+	1.302
150	13	S8	0	1.878	1484.24	1143.09	1484.24	9.99+	1.298
151	13	S9	0	1.158	1485.276	1140.365	1485.276	9.99+	1.302
152	13	S11	0	1.158	1485.278	1140.366	1485.278	9.99+	1.302
153	13	S12	0	1.878	1484.238	1143.077	1484.238	9.99+	1.298
154	13	S13	0	1.056	1488.656	1142.967	1488.656	9.99+	1.302
155	13	S14	0	1.858	1470.333	1135.962	1470.333	9.99+	1.294
156	13	S15	0	7.779	1575.09	1168.879	1575.09	9.99+	1.348
157	14	S10	0	141.136	2645.853	1366.665	2645.853	9.99+	1.936
158	14	S2	0	141.136	2645.853	1366.647	2645.853	9.99+	1.936
159	14	S7	0	0	2658.974	1600.839	2658.974	9.99+	1.661
160	14	S4	0	5.629	2571.63	1634.638	2571.63	9.99+	1.573
161	14	S5	0	0.82	2673.626	1591.746	2673.626	9.99+	1.68
162	14	S6	0	0.393	2655.843	1599.132	2655.843	9.99+	1.661
163	14	S8	0	0.844	2660.291	1599.482	2660.291	9.99+	1.663
164	14	S9	0	0.074	2658.853	1596.655	2658.853	9.99+	1.665
165	14	S11	0	0.074	2658.851	1596.657	2658.851	9.99+	1.665
166	14	S12	0	0.844	2660.295	1599.465	2660.295	9.99+	1.663
167	14	S13	0	0.393	2655.845	1599.131	2655.845	9.99+	1.661
168	14	S14	0	0.821	2673.629	1591.759	2673.629	9.99+	1.68
169	14	S15	0	5.63	2571.628	1634.68	2571.628	9.99+	1.573
170	15	S10	0	92.593	2555.99	1235.983	2555.99	9.99+	2.068
171	15	S2	0	92.593	2555.99	1235.968	2555.99	9.99+	2.068
172	15	S7	0	0	2593.225	1446.918	2593.225	9.99+	1.792
173	15	S4	0	1.753	2543.867	1477.45	2543.867	9.99+	1.722
174	15	S5	0	0	2601.877	1440.658	2601.877	9.99+	1.806
175	15	S6	0	0	2591.799	1445.793	2591.799	9.99+	1.793
176	15	S8	0	0	2594.466	1446.223	2594.466	9.99+	1.794
177	15	S9	0	0	2593.301	1444.293	2593.301	9.99+	1.796
178	15	S11	0	0	2593.301	1444.294	2593.301	9.99+	1.796
179	15	S12	0	0	2594.47	1446.208	2594.47	9.99+	1.794
180	15	S13	0	0	2591.801	1445.791	2591.801	9.99+	1.793
181	15	S14	0	0	2601.878	1440.669	2601.878	9.99+	1.806
182	15	S15	0	1.754	2543.866	1477.484	2543.866	9.99+	1.722





JOB NO.: U2716.0385.241

**PROJECT:** Sunturf Package A16 Ground Mount

---

# ANCHORAGE DESIGN FOR CONCRETE BALLAST BLOCK

**Load Combinations**

	Description	Solve	P-Delta	BLC	Factor	BLC	Factor	BLC	Factor	BLC	Factor
1	ASD Loads		Y								
2	1.0 D		Y	DL	1						
3	1.0 D + 1.0 S		Y	DL	1	RLL	1				
4	1.0 D + 0.6 W1		Y	DL	1	RLL		OL1	0.6	WLZ	0.6
5	1.0 D + 0.6 W2		Y	DL	1	RLL		OL2	0.6	WLZ	0.6
6	1.0 D + 0.6 W3		Y	DL	1	RLL		OL3	0.6	WLZ	-0.6
7	1.0 D + 0.6 W4		Y	DL	1	RLL		OL4	0.6	WLZ	-0.6
8	1.0 D + 0.45 W1 + 0.75 S		Y	DL	1	RLL	0.75	OL1	0.45	WLZ	0.45
9	1.0 D + 0.45 W2 + 0.75 S		Y	DL	1	RLL	0.75	OL2	0.45	WLZ	0.45
10	1.0 D + 0.45 W3 + 0.75 S		Y	DL	1	RLL	0.75	OL3	0.45	WLZ	-0.45
11	1.0 D + 0.45 W4 + 0.75 S		Y	DL	1	RLL	0.75	OL4	0.45	WLZ	-0.45
12	0.6 D + 0.6 W1		Y	DL	0.6	RLL		OL1	0.6	WLZ	0.6
13	0.6 D + 0.6 W2		Y	DL	0.6	RLL		OL2	0.6	WLZ	0.6
14	0.6 D + 0.6 W3		Y	DL	0.6	RLL		OL3	0.6	WLZ	-0.6
15	0.6 D + 0.6 W4		Y	DL	0.6	RLL		OL4	0.6	WLZ	-0.6
16			Y								
17	LRFD Loads		Y								
18	1.4 D	Yes	Y	DL	1.4	RLL					
19	1.2 D + 1.6 S + 0.5 W1	Yes	Y	DL	1.2	RLL	1.6	OL1	0.5		
20	1.2 D + 1.6 S + 0.5 W2	Yes	Y	DL	1.2	RLL	1.6	OL2	0.5		
21	1.2 D + 1.6 S + 0.5 W3	Yes	Y	DL	1.2	RLL	1.6	OL3	0.5		
22	1.2 D + 1.6 S + 0.5 W4	Yes	Y	DL	1.2	RLL	1.6	OL4	0.5		
23	1.2 D + 1.0 W1	Yes	Y	DL	1.2	RLL		OL1	1		
24	1.2 D + 1.0 W2	Yes	Y	DL	1.2	RLL		OL2	1		
25	1.2 D + 1.0 W3	Yes	Y	DL	1.2	RLL		OL3	1		
26	1.2 D + 1.0 W4	Yes	Y	DL	1.2	RLL		OL4	1		
27	0.9 D + 1.0 W1	Yes	Y	DL	0.9	RLL		OL1	1		
28	0.9 D + 1.0 W2	Yes	Y	DL	0.9	RLL		OL2	1		
29	0.9 D + 1.0 W3	Yes	Y	DL	0.9	RLL		OL3	1		
30	0.9 D + 1.0 W4	Yes	Y	DL	0.9	RLL		OL4	1		

**Envelope Node Reactions**

Node Label	X [lb]	LC	Y [lb]	LC	Z [lb]	LC	MX [lb-ft]	LC	MY [lb-ft]	LC	MZ [lb-ft]	LC
1 N2 max	26.131	22	2922.098	20	179.725	23	0	30	0	30	0	30
2 min	-6.144	27	-463.212	29	-210.035	25	0	18	0	18	0	18
3 N1 max	318.59	21	4939.579	21	2485.5	25	0	30	0	30	0	30
4 min	-214.482	28	-3916.499	28	-2131.857	23	0	18	0	18	0	18
5 N151 max	214.489	28	4939.449	21	2485.532	25	0	30	0	30	0	30
6 min	-318.595	21	-3916.52	28	-2131.884	23	0	18	0	18	0	18
7 N152 max	6.138	27	2922.211	20	179.726	23	0	30	0	30	0	30
8 min	-26.117	22	-463.229	29	-210.035	25	0	18	0	18	0	18
9 N276 max	9.983	21	4273.721	21	2956.596	25	0	30	0	30	0	30
10 min	-7.049	28	-3574.806	28	-2525.798	23	0	18	0	18	0	18
11 N278 max	2.277	29	3532.556	20	194.925	23	0	30	0	30	0	30
12 min	-7.115	20	-569.433	29	-227.688	25	0	18	0	18	0	18
13 N215 max	1.45	28	5058.719	21	2880.174	25	0	30	0	30	0	30
14 min	-1.725	21	-4111.292	28	-2471.254	23	0	18	0	18	0	18
15 N217 max	1.825	20	3419.105	20	197.349	23	0	30	0	30	0	30
16 min	-0.68	29	-551.126	29	-230.261	25	0	18	0	18	0	18
17 N230 max	1.716	21	4929.483	21	2897.894	25	0	30	0	30	0	30
18 min	-1.247	28	-4016.513	28	-2480.504	23	0	18	0	18	0	18
19 N235 max	3.944	20	3432.321	20	198.431	23	0	30	0	30	0	30
20 min	-1.935	29	-553.895	29	-231.709	25	0	18	0	18	0	18
21 N239 max	1.594	21	4958.813	21	2897.705	25	0	30	0	30	0	30

**Envelope Node Reactions (Continued)**

Node Label		X [lb]	LC	Y [lb]	LC	Z [lb]	LC	MX [lb-ft]	LC	MY [lb-ft]	LC	MZ [lb-ft]	LC
22		min	28	-1.219	28	-4042.063	28	-2482.185	23	0	18	0	18
23	N241	max	20	5.541	20	3433.751	20	198.833	23	0	30	0	30
24		min	29	-2.636	29	-554.465	29	-232.103	25	0	18	0	18
25	N245	max	21	1.827	21	4944.725	21	2893.293	25	0	30	0	30
26		min	28	-1.314	28	-4027.272	28	-2477.965	23	0	18	0	18
27	N247	max	20	5.261	20	3425.176	20	198.828	23	0	30	0	30
28		min	29	-1.401	29	-546.993	29	-232.147	25	0	18	0	18
29	N251	max	20	0	20	4949.426	21	2900.288	25	0	30	0	30
30		min	28	-0.001	28	-4037.403	28	-2484.269	23	0	18	0	18
31	N253	max	28	0.001	28	3427.98	20	199.062	23	0	30	0	30
32		min	22	-0.001	22	-555.75	29	-232.313	25	0	18	0	18
33	N257	max	28	1.313	28	4944.71	21	2893.296	25	0	30	0	30
34		min	21	-1.828	21	-4027.262	28	-2477.968	23	0	18	0	18
35	N259	max	29	1.402	29	3425.18	20	198.828	23	0	30	0	30
36		min	20	-5.262	20	-546.991	29	-232.147	25	0	18	0	18
37	N263	max	28	1.218	28	4958.813	21	2897.673	25	0	30	0	30
38		min	21	-1.594	21	-4042.052	28	-2482.16	23	0	18	0	18
39	N265	max	29	2.636	29	3433.753	20	198.832	23	0	30	0	30
40		min	20	-5.542	20	-554.424	29	-232.102	25	0	18	0	18
41	N269	max	28	1.246	28	4929.497	21	2897.891	25	0	30	0	30
42		min	21	-1.716	21	-4016.522	28	-2480.502	23	0	18	0	18
43	N271	max	29	1.934	29	3432.327	20	198.431	23	0	30	0	30
44		min	20	-3.945	20	-553.892	29	-231.709	25	0	18	0	18
45	N282	max	21	1.724	21	5058.736	21	2880.198	25	0	30	0	30
46		min	28	-1.451	28	-4111.326	28	-2471.275	23	0	18	0	18
47	N284	max	29	0.68	29	3419.119	20	197.351	23	0	30	0	30
48		min	20	-1.825	20	-551.286	29	-230.264	25	0	18	0	18
49	N286	max	28	7.047	28	4273.919	21	2956.677	25	0	30	0	30
50		min	21	-9.981	21	-3574.916	28	-2525.863	23	0	18	0	18
51	N288	max	20	7.112	20	3532.537	20	194.931	23	0	30	0	30
52		min	29	-2.28	29	-569.603	29	-227.694	25	0	18	0	18
53	Totals:	max	28	0.001	28	92915.365	21	33962.509	25				
54		min	25	0	25	-37648.616	27	-29088.235	27				



Company:	Vector Structural Engineers	Date:	3/20/2024
Engineer:	CJT	Page:	1/6
Project:	Sunturf Ground Mount A16		
Address:			
Phone:			
E-mail:			

**1. Project information**

Customer company: SunModo  
Customer contact name:  
Customer e-mail:  
Comment:

Project description:  
Location:  
Fastening description: Anchorage to concrete ballast block

**2. Input Data & Anchor Parameters**

**General**

Design method: ACI 318-19  
Units: Imperial units

**Anchor Information:**

Anchor type: Bonded anchor  
Material: F593 304/316SS  
Diameter (inch): 0.375  
Effective Embedment depth,  $h_{ef}$  (inch): 6.000  
Code report: ICC-ES ESR-4057  
Anchor category: -  
Anchor ductility: Yes  
 $h_{min}$  (inch): 7.25  
 $c_{ac}$  (inch): 10.99  
 $C_{min}$  (inch): 1.75  
 $S_{min}$  (inch): 1.00

**Base Material**

Concrete: Normal-weight  
Concrete thickness,  $h$  (inch): 32.00  
State: Cracked  
Compressive strength,  $f'_c$  (psi): 2500  
 $\Psi_{c,v}$ : 1.0  
Reinforcement condition: Supplementary reinforcement not present  
Supplemental edge reinforcement: Not applicable  
Reinforcement provided at corners: No  
Ignore concrete breakout in tension: No  
Ignore concrete breakout in shear: No  
Hole condition: Dry concrete  
Inspection: Periodic  
Temperature range, Short/Long: 150/110°F  
Reduced installation torque (for AT-3G): Not applicable  
Ignore 6do requirement: Not applicable  
Build-up grout pad: No

**Base Plate**

Length x Width x Thickness (inch): 4.75 x 4.75 x 0.31

**Recommended Anchor**

Anchor Name: SET-3G™ - SET-3G w/ 3/8"Ø F593 CW (304/316SS)  
Code Report: ICC-ES ESR-4057





Company:	Vector Structural Engineers	Date:	3/20/2024
Engineer:	CJT	Page:	2/6
Project:	Sunturf Ground Mount A16		
Address:			
Phone:			
E-mail:			

**Load and Geometry**

Load factor source: ACI 318 Section 5.3

Load combination: not set

Seismic design: No

Anchors subjected to sustained tension: No

Apply entire shear load at front row: No

Anchors only resisting wind and/or seismic loads: No

Strength level loads:

$N_{ua}$  [lb]: 4112

$V_{uax}$  [lb]: 319

$V_{uay}$  [lb]: 2957

$M_{ux}$  [ft-lb]: 0

$M_{uy}$  [ft-lb]: 0

$M_{uz}$  [ft-lb]: 0

<Figure 1>

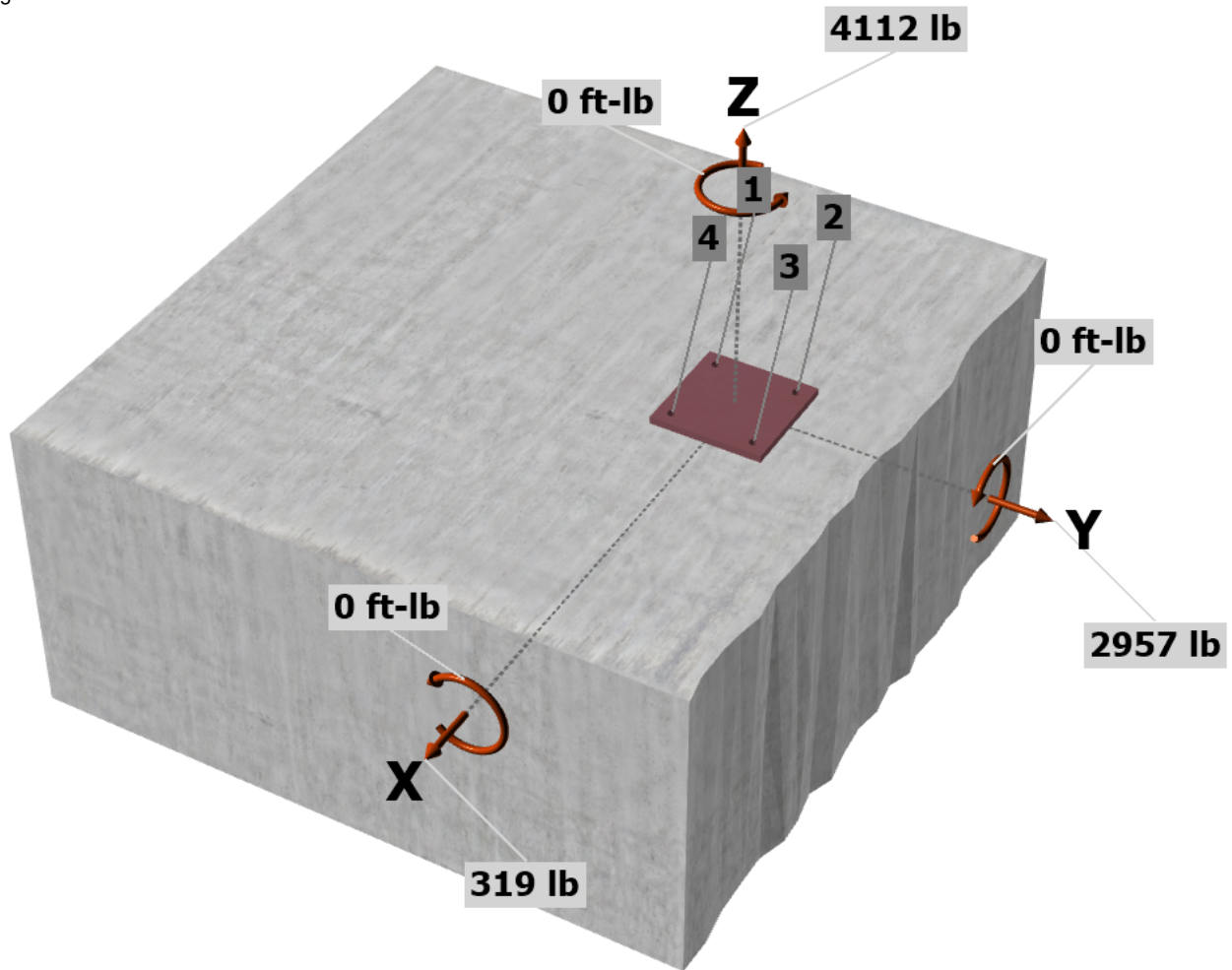

Input data and results must be checked for agreement with the existing circumstances, the standards and guidelines must be checked for plausibility.



Company:	Vector Structural Engineers	Date:	3/20/2024
Engineer:	CJT	Page:	3/6
Project:	Sunturf Ground Mount A16		
Address:			
Phone:			
E-mail:			

<Figure 2>

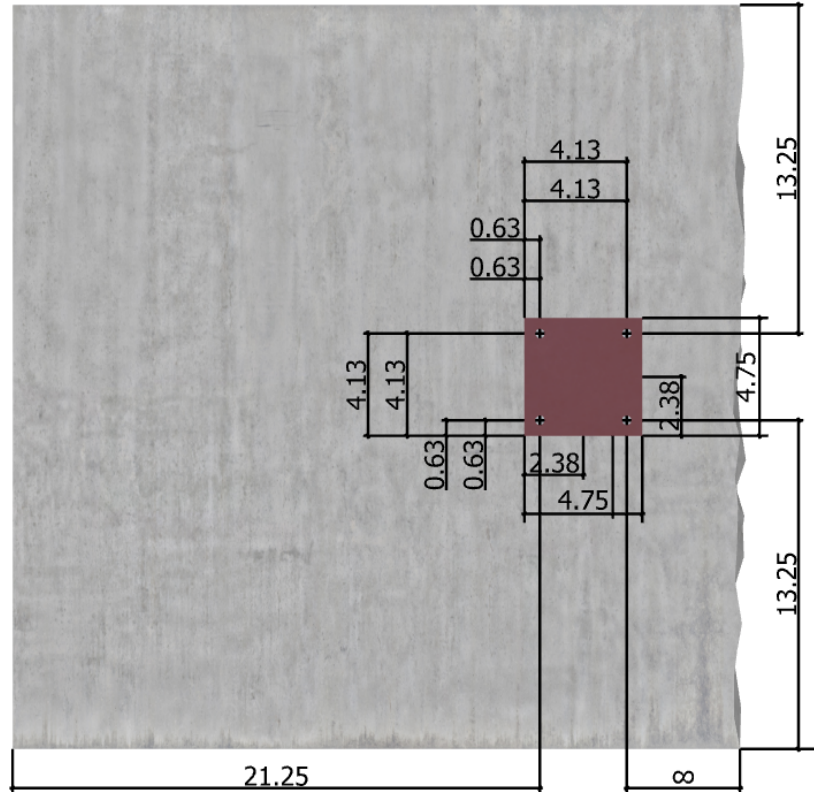



Company:	Vector Structural Engineers	Date:	3/20/2024
Engineer:	CJT	Page:	4/6
Project:	Sunturf Ground Mount A16		
Address:			
Phone:			
E-mail:			

### 3. Resulting Anchor Forces

Anchor	Tension load, $N_{ua}$ (lb)	Shear load x, $V_{uax}$ (lb)	Shear load y, $V_{uay}$ (lb)	Shear load combined, $\sqrt{(V_{uax})^2 + (V_{uay})^2}$ (lb)
1	1028.0	79.7	739.3	743.6
2	1028.0	79.8	739.3	743.6
3	1028.0	79.8	739.2	743.5
4	1028.0	79.7	739.2	743.5
Sum	4112.0	319.0	2957.0	2974.2

Maximum concrete compression strain (%): 0.00  
 Maximum concrete compression stress (psi): 0  
 Resultant tension force (lb): 4112  
 Resultant compression force (lb): 0  
 Eccentricity of resultant tension forces in x-axis,  $e'_{Nx}$  (inch): 0.00  
 Eccentricity of resultant tension forces in y-axis,  $e'_{Ny}$  (inch): 0.00  
 Eccentricity of resultant shear forces in x-axis,  $e'_{Vx}$  (inch): 0.00  
 Eccentricity of resultant shear forces in y-axis,  $e'_{Vy}$  (inch): 0.00

<Figure 3>

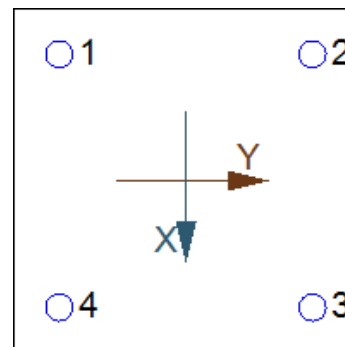

### 4. Steel Strength of Anchor in Tension (Sec. 17.6.1)

$N_{sa}$ (lb)	$\phi$	$\phi N_{sa}$ (lb)
7800	0.75	5850

### 5. Concrete Breakout Strength of Anchor in Tension (Sec. 17.6.2)

$$N_b = K_c \lambda_a \sqrt{f_c} c_{hef}^{1.5} \text{ (Eq. 17.6.2.2.1)}$$

$K_c$	$\lambda_a$	$f_c$ (psi)	$h_{ef}$ (in)	$N_b$ (lb)
17.0	1.00	2500	6.000	12492

$$\phi N_{cbg} = \phi (A_{Nc} / A_{Nco}) \Psi_{ec,N} \Psi_{ed,N} \Psi_{c,N} \Psi_{cp,N} N_b \text{ (Sec. 17.5.1.2 \& Eq. 17.6.2.1a)}$$

$A_{Nc}$ (in <sup>2</sup> )	$A_{Nco}$ (in <sup>2</sup> )	$C_{a,min}$ (in)	$\Psi_{ec,N}$	$\Psi_{ed,N}$	$\Psi_{c,N}$	$\Psi_{cp,N}$	$N_b$ (lb)	$\phi$	$\phi N_{cbg}$ (lb)
462.25	324.00	13.25	1.000	1.000	1.00	1.000	12492	0.65	11585

### 6. Adhesive Strength of Anchor in Tension (Sec. 17.6.5)

$$\tau_{k,cr} = \tau_{k,cr,short-term} K_{sat} (f_c / 2,500)^0$$

$\tau_{k,cr}$ (psi)	$f_{short-term}$	$K_{sat}$	$f_c$ (psi)	$n$	$\tau_{k,cr}$ (psi)
1346	1.00	1.00	2500	0.24	1346

$$N_{ba} = \lambda_a \tau_{cr} \pi d_a h_{ef} \text{ (Eq. 17.6.5.2.1)}$$

$\lambda_a$	$\tau_{cr}$ (psi)	$d_a$ (in)	$h_{ef}$ (in)	$N_{ba}$ (lb)
1.00	1346	0.38	6.000	9514

$$\phi N_{ag} = \phi (A_{Na} / A_{Na0}) \Psi_{ec,Na} \Psi_{ed,Na} \Psi_{cp,Na} N_{ba} \text{ (Sec. 17.5.1.2 \& Eq. 17.6.5.1b)}$$

$A_{Na}$ (in <sup>2</sup> )	$A_{Na0}$ (in <sup>2</sup> )	$C_{Na}$ (in)	$C_{a,min}$ (in)	$\Psi_{ec,Na}$	$\Psi_{ed,Na}$	$\Psi_{cp,Na}$	$N_{ba}$ (lb)	$\phi$	$\phi N_{ag}$ (lb)
198.45	112.09	5.29	13.25	1.000	1.000	1.000	9514	0.55	9265

Input data and results must be checked for agreement with the existing circumstances, the standards and guidelines must be checked for plausibility.



Company:	Vector Structural Engineers	Date:	3/20/2024
Engineer:	CJT	Page:	5/6
Project:	Sunturf Ground Mount A16		
Address:			
Phone:			
E-mail:			

**8. Steel Strength of Anchor in Shear (Sec. 17.7.1)**

$V_{sa}$ (lb)	$\phi_{grout}$	$\phi$	$\phi_{grout}\phi V_{sa}$ (lb)
4680	1.0	0.65	3042

**9. Concrete Breakout Strength of Anchor in Shear (Sec. 17.7.2)**

**Shear perpendicular to edge in x-direction:**

$$V_{bx} = \min|7(l_e / d_a)^{0.2} \sqrt{d_a} \lambda_a \sqrt{f_c} c_{a1}^{1.5}; 9 \lambda_a \sqrt{f_c} c_{a1}^{1.5}| \text{ (Eq. 17.7.2.2.1a \& Eq. 17.7.2.2.1b)}$$

$l_e$ (in)	$d_a$ (in)	$\lambda_a$	$f_c$ (psi)	$c_{a1}$ (in)	$V_{bx}$ (lb)
3.00	0.375	1.00	2500	16.75	22270

$$\phi V_{cbgx} = \phi (A_{vc} / A_{vco}) \psi_{ec,v} \psi_{ed,v} \psi_{c,v} \psi_{h,v} V_{bx} \text{ (Sec. 17.5.1.2 \& Eq. 17.7.2.1b)}$$

$A_{vc}$ (in <sup>2</sup> )	$A_{vco}$ (in <sup>2</sup> )	$\psi_{ec,v}$	$\psi_{ed,v}$	$\psi_{c,v}$	$\psi_{h,v}$	$V_{bx}$ (lb)	$\phi$	$\phi V_{cbgx}$ (lb)
1253.11	1262.53	1.000	0.954	1.000	1.000	22270	0.70	14756

**Shear parallel to edge in y-direction:**

$$V_{by} = \min|7(l_e / d_a)^{0.2} \sqrt{d_a} \lambda_a \sqrt{f_c} c_{a1}^{1.5}; 9 \lambda_a \sqrt{f_c} c_{a1}^{1.5}| \text{ (Eq. 17.7.2.2.1a \& Eq. 17.7.2.2.1b)}$$

$l_e$ (in)	$d_a$ (in)	$\lambda_a$	$f_c$ (psi)	$c_{a1}$ (in)	$V_{by}$ (lb)
3.00	0.375	1.00	2500	21.25	31823

$$\phi V_{cbgy} = \phi (2)(A_{vc} / A_{vco}) \psi_{ec,v} \psi_{ed,v} \psi_{c,v} \psi_{h,v} V_{by} \text{ (Sec. 17.5.1.2, 17.7.2.1(c) \& Eq. 17.7.2.1b)}$$

$A_{vc}$ (in <sup>2</sup> )	$A_{vco}$ (in <sup>2</sup> )	$\psi_{ec,v}$	$\psi_{ed,v}$	$\psi_{c,v}$	$\psi_{h,v}$	$V_{by}$ (lb)	$\phi$	$\phi V_{cbgy}$ (lb)
956.25	2032.03	1.000	1.000	1.000	1.000	31823	0.70	20966

**Shear parallel to edge in x-direction:**

$$V_{bx} = \min|7(l_e / d_a)^{0.2} \sqrt{d_a} \lambda_a \sqrt{f_c} c_{a1}^{1.5}; 9 \lambda_a \sqrt{f_c} c_{a1}^{1.5}| \text{ (Eq. 17.7.2.2.1a \& Eq. 17.7.2.2.1b)}$$

$l_e$ (in)	$d_a$ (in)	$\lambda_a$	$f_c$ (psi)	$c_{a1}$ (in)	$V_{bx}$ (lb)
3.00	0.375	1.00	2500	13.25	15668

$$\phi V_{cbgx} = \phi (2)(A_{vc} / A_{vco}) \psi_{ec,v} \psi_{ed,v} \psi_{c,v} \psi_{h,v} V_{bx} \text{ (Sec. 17.5.1.2, 17.7.2.1(c) \& Eq. 17.7.2.1b)}$$

$A_{vc}$ (in <sup>2</sup> )	$A_{vco}$ (in <sup>2</sup> )	$\psi_{ec,v}$	$\psi_{ed,v}$	$\psi_{c,v}$	$\psi_{h,v}$	$V_{bx}$ (lb)	$\phi$	$\phi V_{cbgx}$ (lb)
859.59	790.03	1.000	1.000	1.000	1.000	15668	0.70	23867

**10. Concrete Pryout Strength of Anchor in Shear (Sec. 17.7.3)**

$$\phi V_{cp} = \phi \min|k_{cp} N_{ag}; k_{cp} N_{cbg}| = \phi \min|k_{cp} (A_{Na} / A_{Na0}) \psi_{ec,Na} \psi_{ed,Na} \psi_{cp,Na} N_{ba}; k_{cp} (A_{Nc} / A_{Nco}) \psi_{ec,N} \psi_{ed,N} \psi_{c,N} \psi_{cp,N} N_b| \text{ (Sec. 17.5.1.2 \& Eq. 17.7.3.1b)}$$

$k_{cp}$	$A_{Na}$ (in <sup>2</sup> )	$A_{Na0}$ (in <sup>2</sup> )	$\psi_{ed,Na}$	$\psi_{ec,Na}$	$\psi_{cp,Na}$	$N_{ba}$ (lb)	$N_a$ (lb)
2.0	198.45	112.09	1.000	1.000	1.000	9514	16844

$A_{Nc}$ (in <sup>2</sup> )	$A_{Nco}$ (in <sup>2</sup> )	$\psi_{ec,N}$	$\psi_{ed,N}$	$\psi_{c,N}$	$\psi_{cp,N}$	$N_b$ (lb)	$N_{cb}$ (lb)	$\phi$
462.25	324.00	1.000	1.000	1.000	1.000	12492	17822	0.70

$$\phi V_{cp} \text{ (lb)}$$

23581

**11. Results**

**Interaction of Tension and Shear Forces (Sec. 17.8)**

Tension	Factored Load, $N_{ua}$ (lb)	Design Strength, $\phi N_n$ (lb)	Ratio	Status
---------	------------------------------	----------------------------------	-------	--------

Input data and results must be checked for agreement with the existing circumstances, the standards and guidelines must be checked for plausibility.





Anchor Designer™  
Software  
Version 3.1.2303.1

Company:	Vector Structural Engineers	Date:	3/20/2024
Engineer:	CJT	Page:	6/6
Project:	Sunturf Ground Mount A16		
Address:			
Phone:			
E-mail:			

Steel	1028	5850	0.18	Pass
Concrete breakout	4112	11585	0.35	Pass
<b>Adhesive</b>	<b>4112</b>	<b>9265</b>	<b>0.44</b>	<b>Pass (Governs)</b>

Shear	Factored Load, $V_{ua}$ (lb)	Design Strength, $\phi V_n$ (lb)	Ratio	Status
<b>Steel</b>	<b>744</b>	<b>3042</b>	<b>0.24</b>	<b>Pass (Governs)</b>
T Concrete breakout x+	319	14756	0.02	Pass
Concrete breakout y-	159	20966	0.01	Pass
Concrete breakout x-	1479	23867	0.06	Pass
Concrete breakout, combined	-	-	0.06	Pass
Pryout	2974	23581	0.13	Pass

Interaction check	$N_{ua}/\phi N_n$	$V_{ua}/\phi V_n$	Combined Ratio	Permissible	Status
Sec. 17.8.1	0.44	0.00	44.4%	1.0	Pass

**SET-3G w/ 3/8"Ø F593 CW (304/316SS) with hef = 6.000 inch meets the selected design criteria.**

## 12. Warnings

- Designer must exercise own judgement to determine if this design is suitable.
- Refer to manufacturer's product literature for hole cleaning and installation instructions.