



Project Number: U2716-0350-221

February 2, 2024

Sunmodo
14800 NE 65th Street
Vancouver, WA 98682

**REFERENCE: Sunmodo Sunturf Ground Mount A3
Ground Mount PV Array Installation w/ Large Format Panels**

To Whom It May Concern:

Per request of Sunmodo, we have been asked to prepare the structural design of a ground-mounted PV solar array system with several foundation options as shown in the attached calculations. The adopted building code in this jurisdiction is the International Building Code, 2018 Edition (2018 IBC). Vector Structural Engineering requires that we review each site-specific install, and we are not liable for installs at site specific locations we have not reviewed. This document does not address site-specific installations. The following design parameters are used in our analysis:

- Minimum Design Loads for Buildings and Other Structures (ASCE 7-16)
- Design wind speed for risk category I structures: 135 mph
- Wind exposure: C
- Ground snow load: 60 psf
- The ground screws and helical piers must be tested to 1.5 times uplift and 2.0 times lateral reactions found in the table below. A minimum of one ground screw or helical pier must be tested.

| Load (ASD) | Value (lbs) | Factor of Safety | Test Value (lbs) |
|------------|-------------|------------------|------------------|
| UPLIFT | 2651 | 1.5 | 3977 |
| LATERAL | 1806 | 2 | 3612 |

Foundation concrete shall have a minimum compressive strength of 2500 psi at 28 days. Cement for all concrete shall be Type I or II with a minimum of 6% entrained air with a water/cement ratio of 0.50. Maximum aggregate size shall be 3/4". No special inspection of concrete strength is required.

Footings are designed based on an allowable soil bearing pressure of 1500 psf an allowable skin friction of 250 psf, an allowable lateral bearing pressure of 150 pcf, and a coefficient of friction of 0.3. Vector Structural Engineering strongly recommends independent soils testing be performed by a licensed geotechnical engineer to verify the assumed soil parameters.

All ground mounts are to be installed per manufacturer’s recommendations. The use of solar panel support span tables provided by the manufacturer is allowed only where the site conditions and solar panel configuration match the description of the span tables. Electrical engineering is beyond our scope. All work performed must be in accordance with accepted industry-wide methods and applicable safety standards. Vector Structural Engineering assumes no responsibility for improper installation of the solar panels.

Very truly yours,

VECTOR STRUCTURAL ENGINEERING, LLC
WI FIRM LICENSE #: 3372-11

Trevor Hawkes, P.E.
License: 46486-6 - Expires: 07/31/2024
Project Engineer

Enclosures

TPH/mih





JOB NO. U2716-093-191
 PROJECT SUNMODO SUNTURF GROUND MOUNTS A3
 SUBJECT ALL OPTIONS

651 W GALENA PARK BLVD. #101 (801) 990-1775
 DRAPER, UTAH 84020 (801) 990-1776 FAX

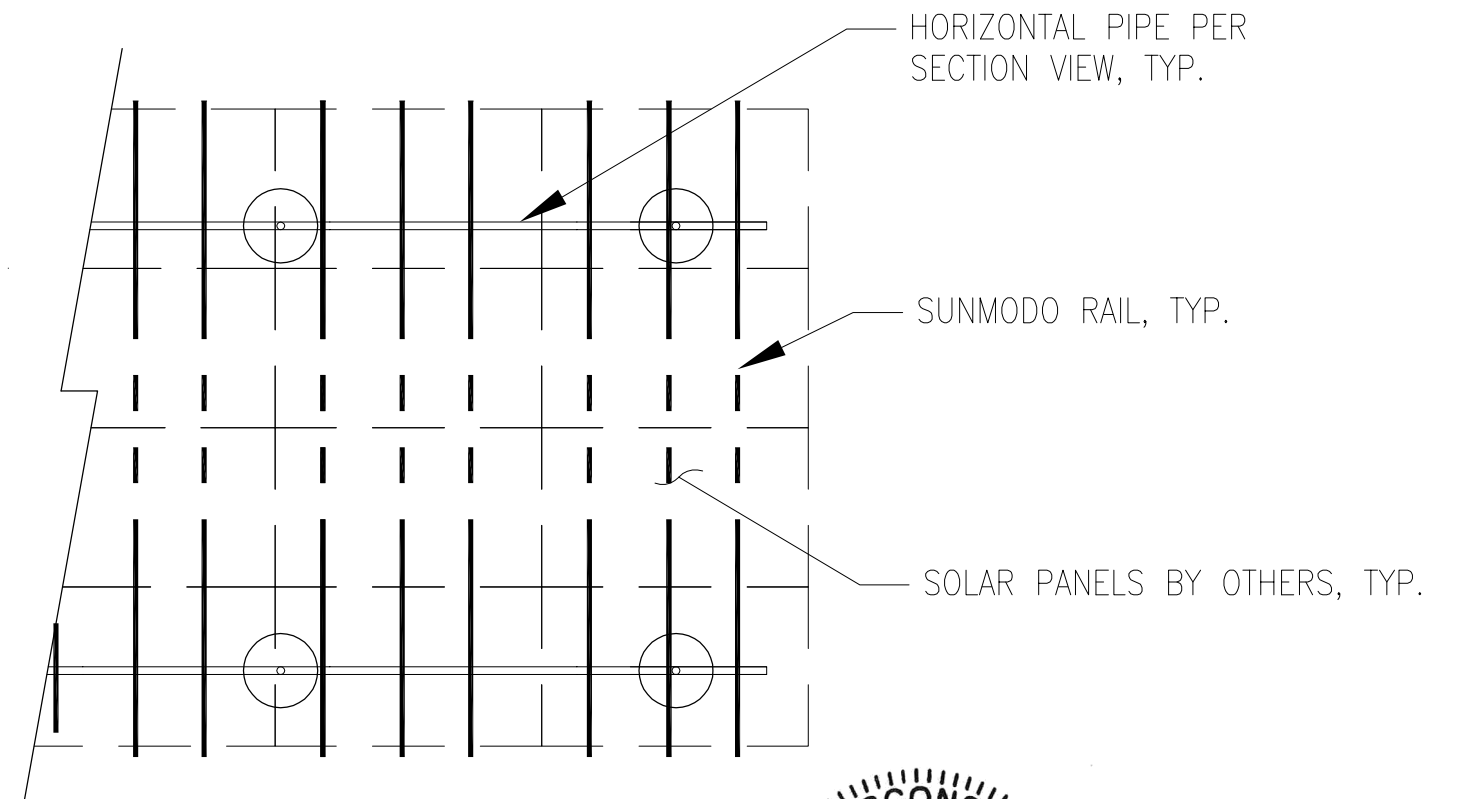
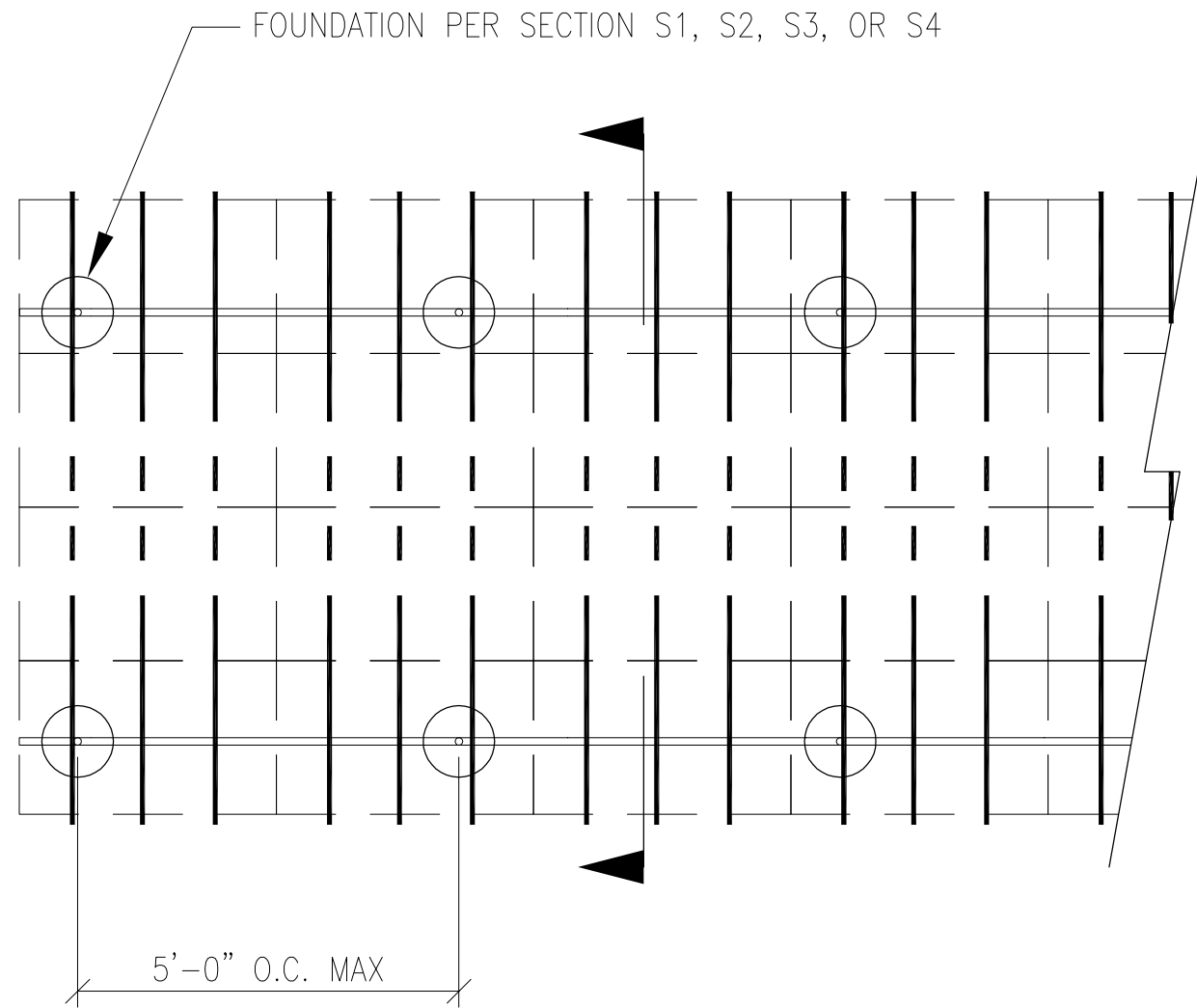

Vector Structural Engineering requires that we review each site-specific install, and we are not liable for installs at site-specific locations we have not reviewed. This document does not address site-specific installations.



PV ARRAY PLAN

02/02/2024

P1

N.T.S.

PROJECT SUNMODO SUNTURF GROUND MOUNTS A3

SUBJECT DRILLED PIER OPTION

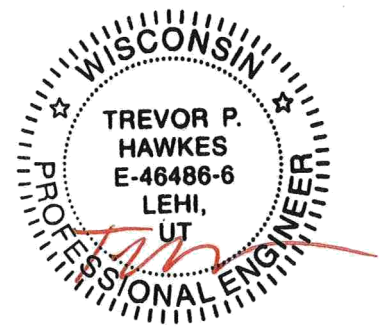
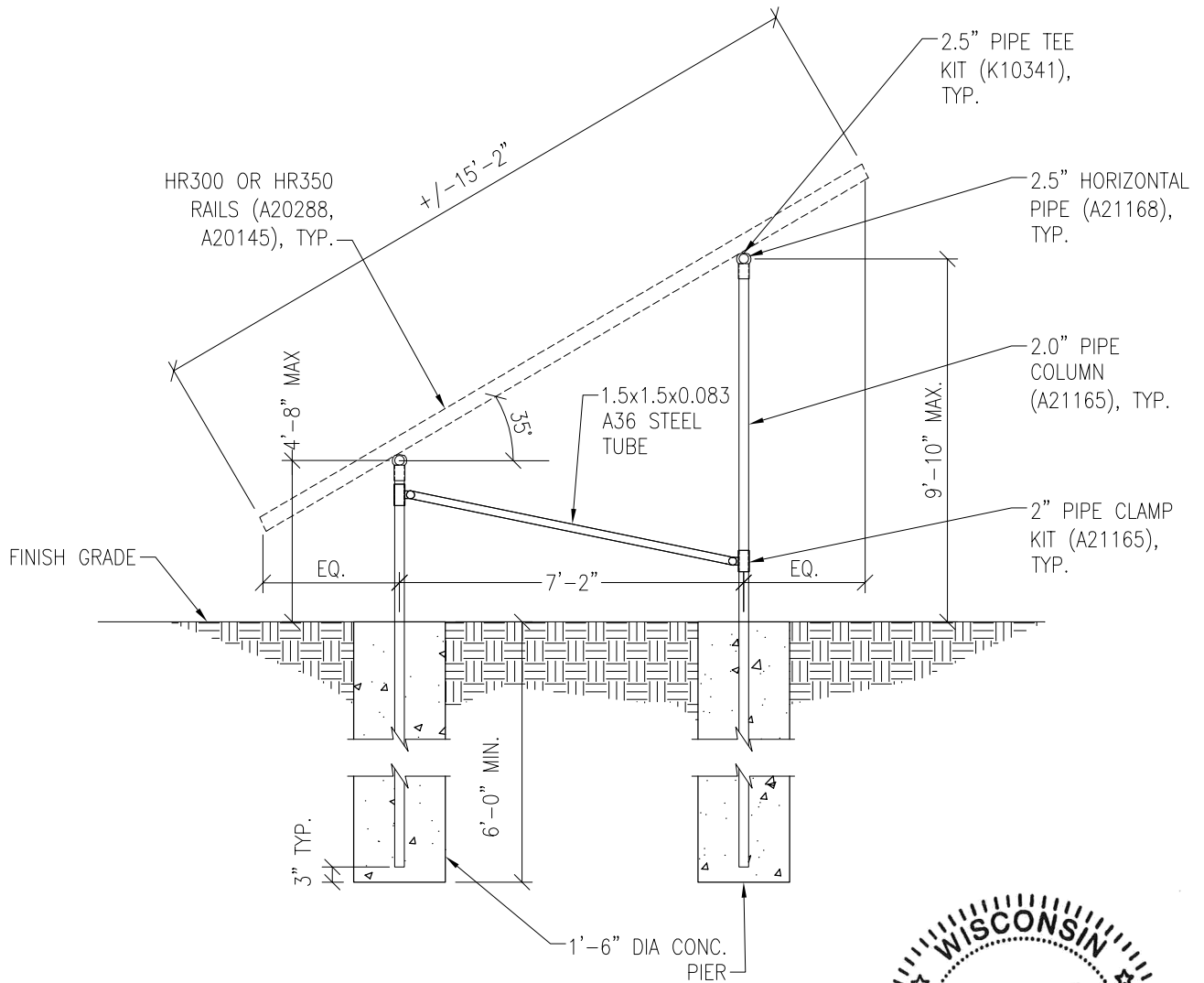

Vector Structural Engineering requires that we review each site-specific install, and we are not liable for installs at site-specific locations we have not reviewed. This document does not address site-specific installations.

PV ARRAY SECTION

02/02/2024

N.T.S.

S1

PROJECT SUNMODO SUNTURF GROUND MOUNTS A3

SUBJECT HELICAL PIER OPTION

NOTES:

1. For ground mount components see Section S1.
2. A minimum of (1) helical pier must be load-tested as follows:
 - 2.1. Safety factor for uplift = 1.5,
 - 2.2. Safety factor for lateral loads = 2.0
 - 2.3. Upward deflection limit = 1/2"
 - 2.4. Lateral deflection limit = 1"
 - 2.5. The load tests must be performed by an approved contractor.

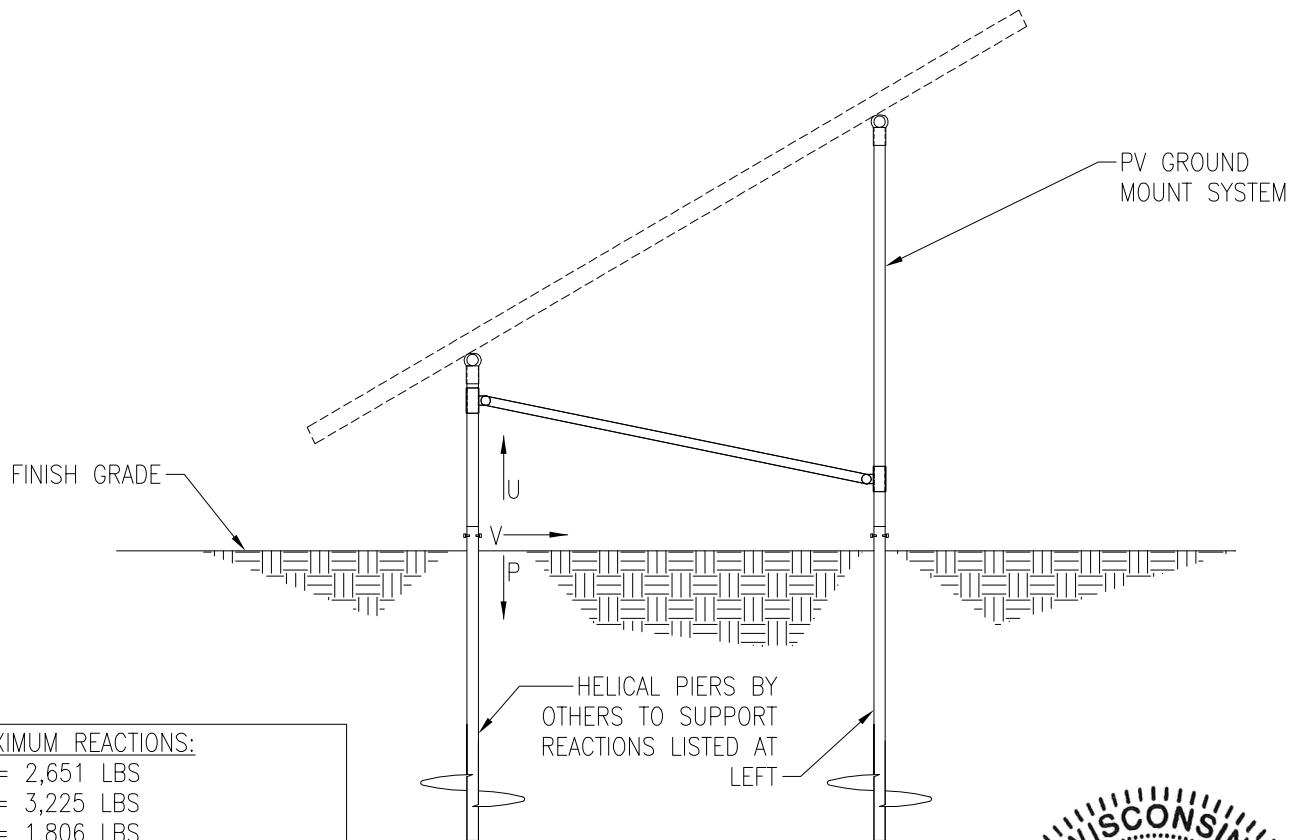

MAXIMUM REACTIONS:
 U = 2,651 LBS
 P = 3,225 LBS
 V = 1,806 LBS

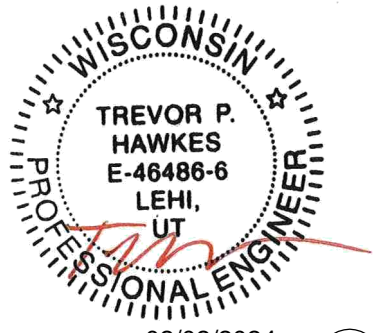

Vector Structural Engineering requires that we review each site-specific install, and we are not liable for installs at site-specific locations we have not reviewed. This document does not address site-specific installations.

PV ARRAY SECTION

02/02/2024

S2

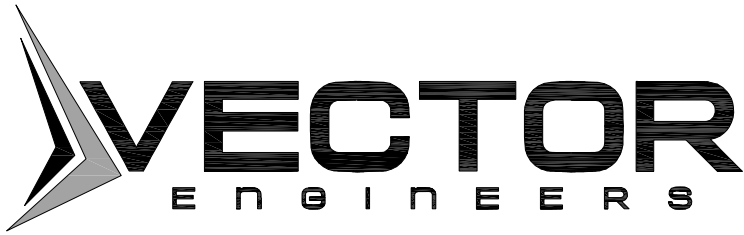

JOB NO. U2716-093-191

PROJECT SUNMODO SUNTURF GROUND MOUNTS A3

SUBJECT GROUND SCREW OPTION

NOTES:

- 1. For ground mount components see Section S1.
- 2. A minimum of (1) ground screw must be load-tested as follows:
 - 2.1. Safety factor for uplift = 1.5,
 - 2.2. Safety factor for lateral loads = 2.0
 - 2.3. Upward deflection limit = 1/2"
 - 2.4. Lateral deflection limit = 1"
 - 2.5. The load tests must be performed by an approved contractor.

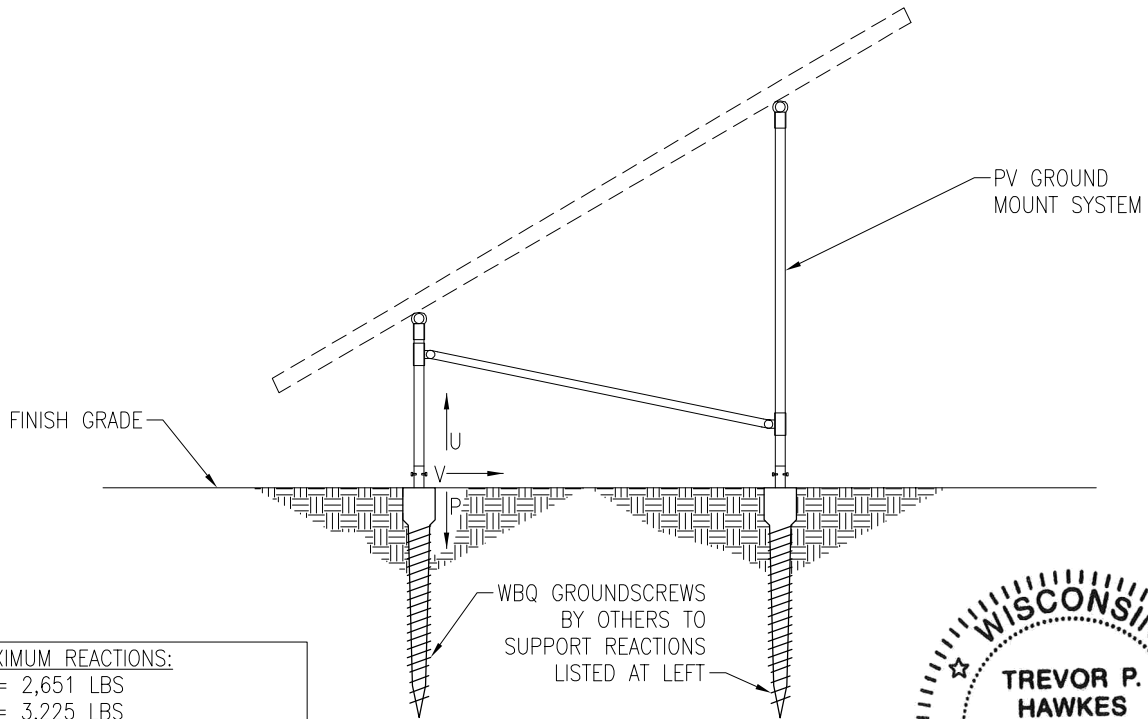

MAXIMUM REACTIONS:
 U = 2,651 LBS
 P = 3,225 LBS
 V = 1,806 LBS



Vector Structural Engineering requires that we review each site-specific install, and we are not liable for installs at site-specific locations we have not reviewed. This document does not address site-specific installations.

PV ARRAY SECTION
 N.T.S.

02/02/2024

S3

651 W GALENA PARK BLVD. #101
 DRAPER, UTAH 84020

(801) 990-1775
 (801) 990-1776 FAX

WWW.VECTORSE.COM



JOB NO. U2716-093-191

PROJECT SUNMODO SUNTURF GROUND MOUNTS A3

SUBJECT BALLASTED BLOCK OPTION

NOTES:

1. For ground mount components see Section S1.

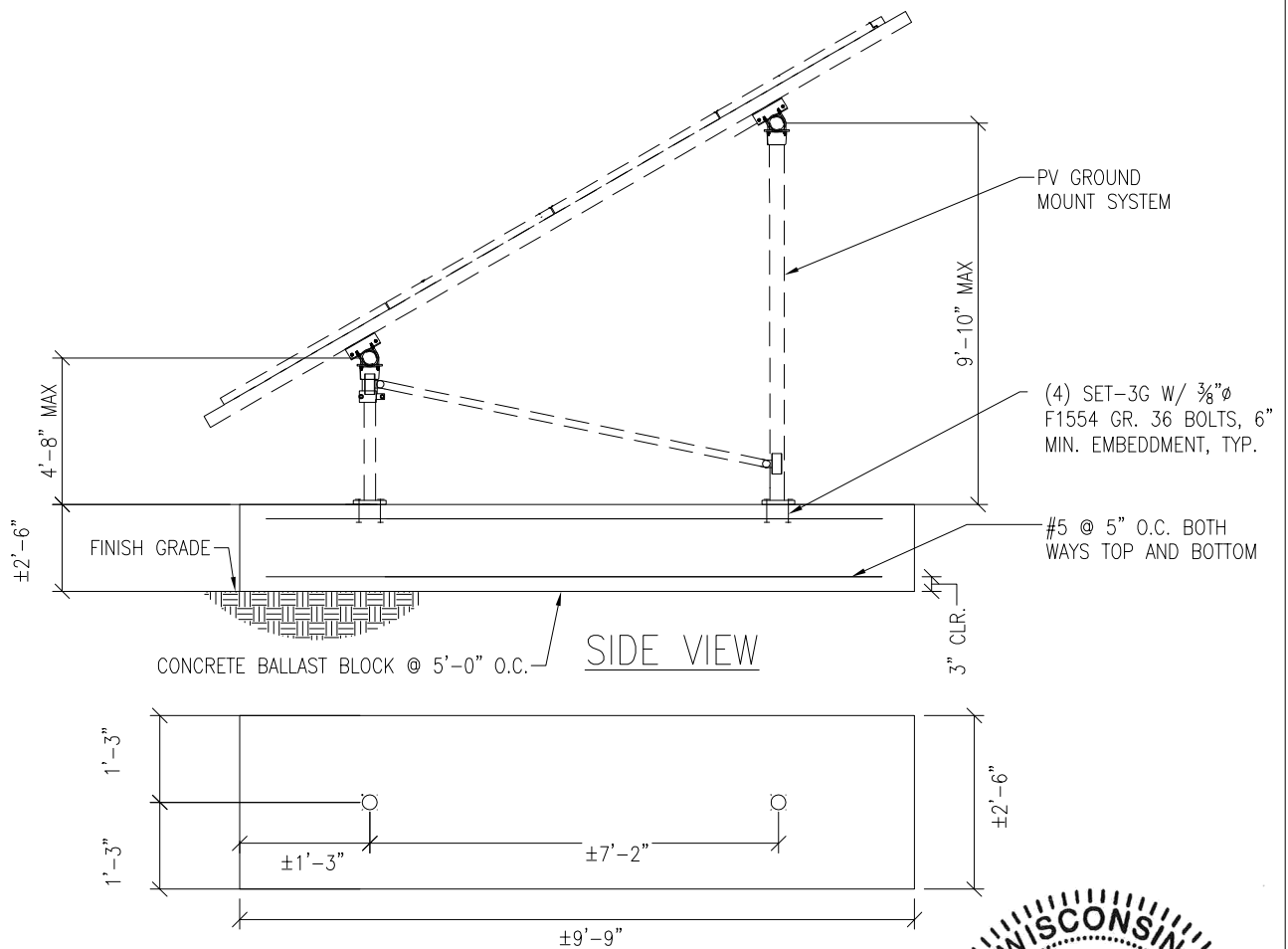

Vector Structural Engineering requires that we review each site-specific install, and we are not liable for installs at site-specific locations we have not reviewed. This document does not address site-specific installations.

PV ARRAY SECTION

N.T.S.



02/02/2024

S4

651 W GALENA PARK BLVD. #101
 DRAPER, UTAH 84020

(801) 990-1775
 (801) 990-1776 FAX

WWW.VECTORSE.COM



JOB NO.: U2716-093-191

DESIGNED: STB

DATE: 07/23/19

PROJECT: A3 – Sunmodo Sunturf GM

SUBJECT: Snow Load

SNOW LOAD (S):

| | | |
|---|---------------|------------------|
| ASCE 7 Standard: | 10 | |
| Panel Slope from Horizontal [°]: | 35.0 | |
| Snow Ground Load, p_g [psf]: | 60.0 | (Section 7.2) |
| Terrain Category: | C | (Table 7-2) |
| Exposure of Roof: | Fully Exposed | (Table 7-2) |
| Exposure Factor, C_e : | 0.9 | (Table 7-2) |
| Thermal Factor, C_t : | 1.2 | (Table 7-3) |
| Risk Category: | I | (Table 1.5-1) |
| Importance Factor, I_s : | 0.8 | (Table 1.5-2) |
| Flat Roof Snow Load, p_f [psf]: | 36 | (Equation 7.3-1) |
| Minimum Roof Snow Load, p_m [psf]: | 0 | (Section 7.3.4) |
| Unobstructed Slippery Surface? | Yes | (Section 7.4) |
| Slope Factor Figure: | Figure 7-2c | (Section 7.4) |
| Roof Slope Factor, C_s : | 0.636 | (Figure 7-2) |
| Sloped Roof Snow Load, p_s [psf]: | 23 | (Equation 7.4-1) |
| Design Snow Load, S [psf]: | 23 | |
| | | |
| Tributary Transverse Length [ft]: | 5.6 | |
| Tributary Longitudinal Length [ft]: | 6 | |
| Tributary Area per Column [ft ²]: | 33.7 | |
| | | |
| Snow Load per Column (1.0 S) [lb]: | 779.3 | |



PROJECT: A3 – Sunmodo Sunturf GM

SUBJECT: Wind Pressure

Design Wind Load:

| | | |
|---|------|-------------------|
| ASCE 7 Standard: | 10 | |
| Basic Wind Speed, V [mph]: | 135 | |
| Risk Category: | I | |
| Exposure Category | C | (Section 26.7.3) |
| Velocity Pressure Exposure Coefficient, K_h : | 0.85 | (Table 27.3-1) |
| Topographic Factor, K_{ht} : | 1.0 | (Section 26.8.2) |
| Wind Directionality Factor, K_d : | 0.85 | (Table 26.6-1) |
| Internal Pressure Coefficient, GC_{pi} : | 0.00 | (Table 26.11-1) |
| Velocity Pressure, q_h [psf]: | 33.7 | (Equation 27.3-1) |
| Gust Effect Factor, G: | 0.85 | (Section 26.9.1) |
| Panel Slope [degrees]: | 35.0 | |

Net Pressure Coefficients (C_N) per: (Figure 27.4-4)

| Clear Wind Flow | C_{NW} | C_{NL} |
|--|----------|----------|
| Case 1 ($\gamma = 0^\circ$, Load Case A) | -1.80 | -1.80 |
| Case 2 ($\gamma = 0^\circ$, Load Case B) | -2.43 | -0.57 |
| Case 3 ($\gamma = 180^\circ$, Load Case A) | 2.10 | 2.17 |
| Case 4 ($\gamma = 180^\circ$, Load Case B) | 2.67 | 1.07 |

Design Wind Pressures (p) [psf] per: (Equation 27.4-3)

| Clear Wind Flow | $q_h GC_{NW}$ | $q_h GC_{NL}$ |
|--|---------------|---------------|
| Case 1 ($\gamma = 0^\circ$, Load Case A) | -51.6 | -51.6 |
| Case 2 ($\gamma = 0^\circ$, Load Case B) | -69.7 | -16.2 |
| Case 3 ($\gamma = 180^\circ$, Load Case A) | 60.2 | 62.1 |
| Case 4 ($\gamma = 180^\circ$, Load Case B) | 76.4 | 30.6 |

Wind Pressure on Each Side of Panels [psf]

| Clear Wind Flow | Short Col. Pressure | Long Col. Pressure |
|--|---------------------|--------------------|
| Case 1 ($\gamma = 0^\circ$, Load Case A) | -51.6 | -51.6 |
| Case 2 ($\gamma = 0^\circ$, Load Case B) | -16.2 | -69.7 |
| Case 3 ($\gamma = 180^\circ$, Load Case A) | 60.2 | 62.1 |
| Case 4 ($\gamma = 180^\circ$, Load Case B) | 76.4 | 30.6 |



JOB NO.: U2716-093-191

PROJECT: A3 – Sunmodo Sunturf GM

SUBJECT: Open Building Wind Loads

Design Wind Load Per ASCE 7-10

$$p = q_h G C_n$$

| | | |
|--|------|------------------|
| Velocity Pressure Exposure Coefficient, K_{zt} : | 0.85 | (Table 27.3-1) |
| Topographic Factor, K_{ht} : | 1.0 | (Section 26.8.2) |
| Wind Directionality Factor, K_d : | 0.85 | (Table 26.6-1) |
| Ultimate Wind Speed, V [mph]: | 135 | |

| | | |
|---------------------------------|------|-------------------|
| Velocity Pressure, q_h [psf]: | 33.7 | (Equation 27.3-1) |
| Gust Effect Factor, G : | 0.85 | (Section 26.9.1) |

$\gamma = 90^\circ$ or 270°

Force Coefficient, C_N :

| Horizontal Distance from Winward Edge | Roof angle | | |
|---------------------------------------|------------|----------------------|------|
| | Load Case | Obstructed Wind Flow | |
| | | CN | |
| $\leq h$ | 35 | A | -0.8 |
| | | B | 0.8 |
| $> h, \leq 2h$ | 35 | A | -0.6 |
| | | B | 0.5 |
| $> 2h$ | 35 | A | -0.3 |
| | | B | 0.3 |

Design Wind Pressure, p [psf]:

| Horizontal Distance from Winward Edge | Roof angle | | |
|---------------------------------------|------------|----------------------|-------|
| | Load Case | Obstructed Wind Flow | |
| $\leq h$ | 35 | A | -22.9 |
| | | B | 22.9 |
| $> h, \leq 2h$ | 35 | A | -17.2 |
| | | B | 14.3 |
| $> 2h$ | 35 | A | -8.6 |
| | | B | 8.6 |



JOB NO.: U2716-093-191

DESIGNED: STB

Foundation Option 1: Drilled Concrete Pier



PROJECT: A3 - Sunturf Ground Mount

DRILLED CONCRETE PIER DESIGN

Column Reactions:

| | | | |
|------------------------|-----|----------------------------------|-----|
| Max. Shear, V [k]: | 1.8 | Max. Down, P _d [k]: | 3.2 |
| Max. Moment, M [k-ft]: | 0.0 | Max. Uplift, P _u [k]: | 2.7 |

Pier Properties:

| | | | |
|-----------------------------|-------|--|-----|
| Pier Shape: | Round | Volume of Concrete [ft ³]: | 11 |
| Pier Diameter, b [ft]: | 1.5 | Volume of Concrete [yd ³]: | 0.4 |
| Top of Pier Elevation [ft]: | 0.00 | Weight of Concrete [k]: | 1.6 |
| Pier Depth, d [ft]: | 6.0 | | |

Soil Properties:

| | | | |
|--------------------------------------|-------|--|-----|
| Allow. Bearing Pressure [psf]: | 1,500 | <u>Optional Parameters for Uplift:</u> | |
| 1/3 increase for short term loads? | No | | |
| Lateral Bearing, S [pcf]: | 150 | Skin Friction* [psf]: | 250 |
| Max. Lateral Bearing (opt'l) [psf]: | | Top Length to Ignore [ft]: | 0 |
| Top Depth to Ignore [ft]: | 0 | 1/3 increase for short term loads? | No |
| 1/3 increase for short term loads? | No | Combine w/ Bearing: | No |
| 1/2" deflection at t/o pier allowed: | Yes | | |

*per IBC Section 1810.3.3.1.4

Check Bearing:

| | |
|-----------------------|-----|
| Bearing Capacity [k]: | 7.1 |
|-----------------------|-----|

Bearing capacity OK.

Check Uplift:

| | |
|----------------------|-----|
| Uplift Capacity [k]: | 8.5 |
|----------------------|-----|

Uplift capacity OK.

Check Lateral Bearing:

| | | |
|--|-------|------------------------|
| Top of Pier Constrained?: | No | IBC Section 1807.3.2.1 |
| Applied Lateral Force, P [lb]: | 1,806 | |
| Point of Application, h [ft]: | 0.0 | |
| S _{max} [psf]: | | |
| S [psf]: | 600 | |
| A = 2.34*P/(S _b): | 4.70 | |
| Required Pier Depth, d _{reqd} [ft]: | 4.70 | IBC Eq. 18-1 |

Result: **Lateral bearing capacity OK.**

Foundation Option 2: Helical Pier

The ground screws and helical piers must be tested to 1.5 times uplift and 2.0 times lateral reactions found in the table below.

| Load (ASD) | Value (lbs) | Factor of Safety | Test Value (lbs) |
|------------|-------------|------------------|------------------|
| UPLIFT | 2651 | 1.5 | 3977 |
| LATERAL | 1806 | 2 | 3612 |

Foundation Option 3: Ground Screw

The ground screws and helical piers must be tested to 1.5 times uplift and 2.0 times lateral reactions found in the table below.

| Load (ASD) | Value (lbs) | Factor of Safety | Test Value (lbs) |
|------------|-------------|------------------|------------------|
| UPLIFT | 2651 | 1.5 | 3977 |
| LATERAL | 1806 | 2 | 3612 |



JOB NO.: U2716-093-191

DESIGNED: STB

Foundation Option 4: Ballasted Block

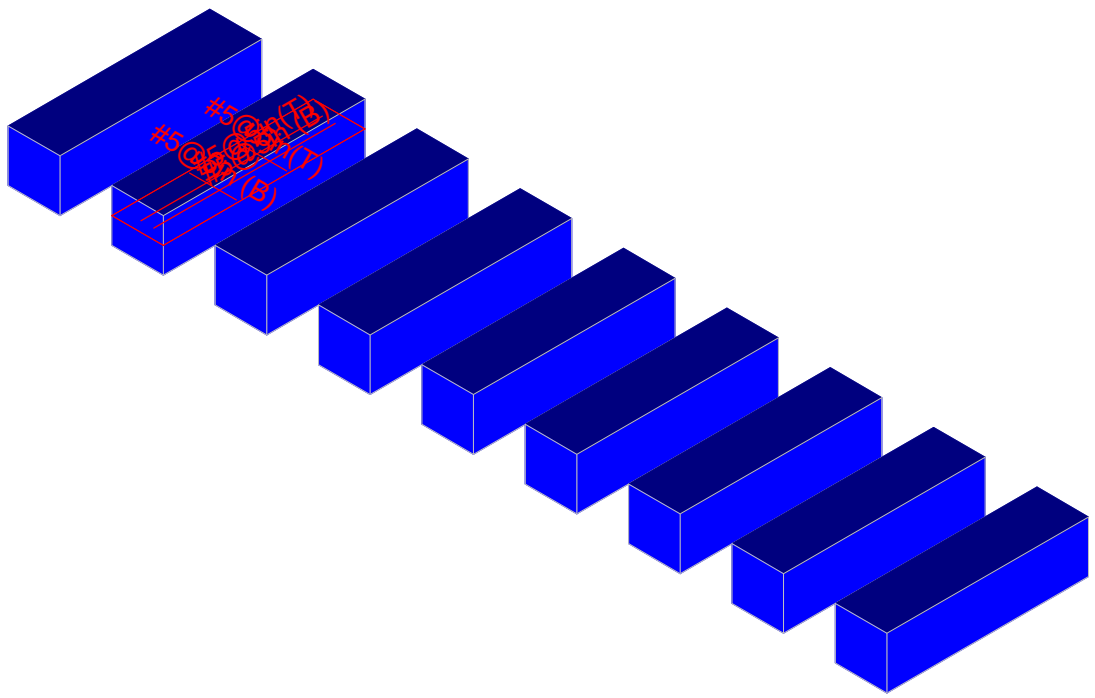

Results for LC 1, 1.0 D

| | | |
|-------------------------------|--------------|---------------------------------|
| Vector Structural Engineeri.. | Ground Mount | SK - 2 |
| STB | | Apr 12, 2021 at 3:08 PM |
| U2716.091.181 | | Sunmodo Sunturf A3 v7 85x45.r3d |

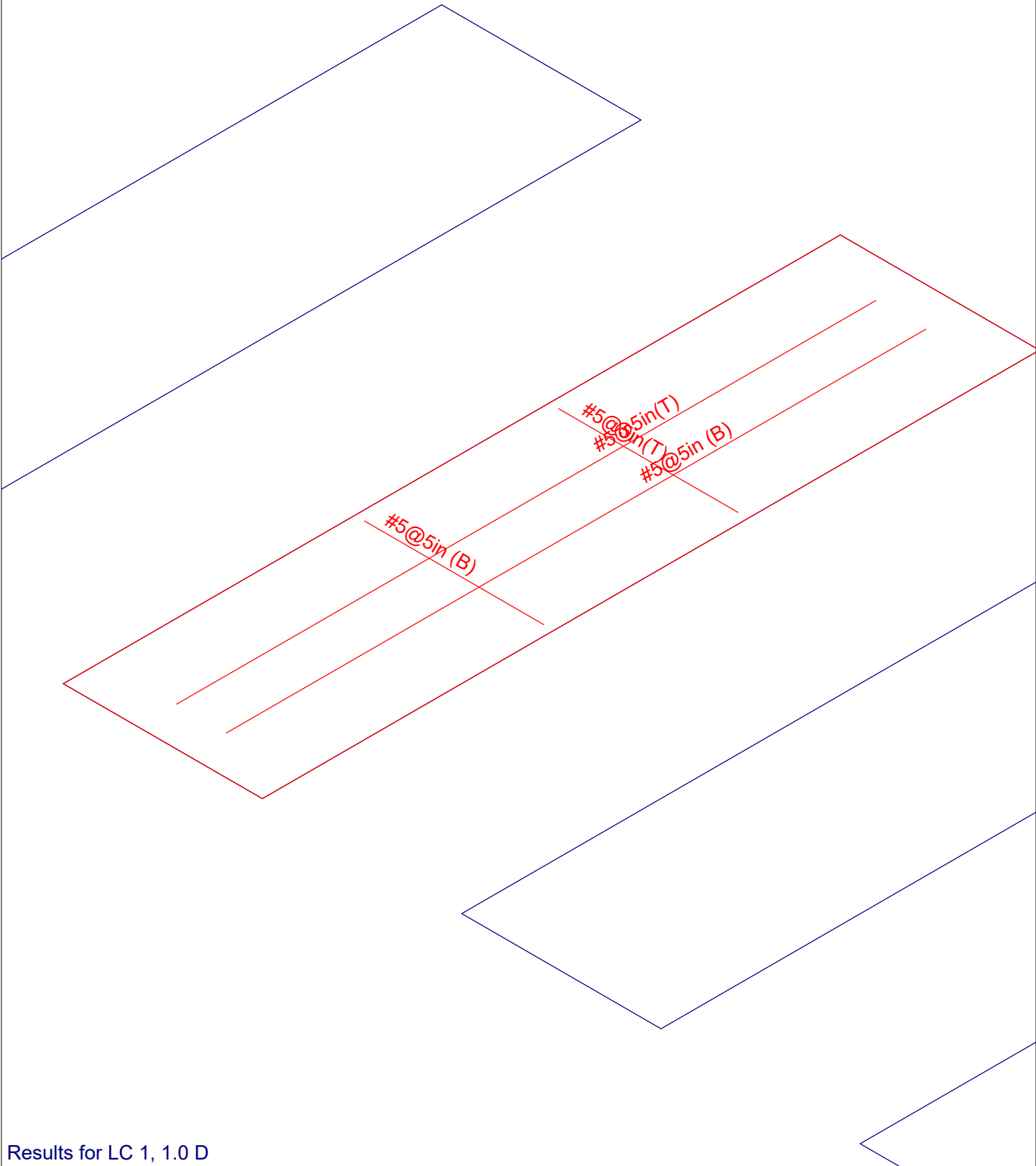

Results for LC 1, 1.0 D

| | | |
|-------------------------------|--------------|---------------------------------|
| Vector Structural Engineeri.. | Ground Mount | SK - 1 |
| STB | | Apr 12, 2021 at 3:08 PM |
| U2716.091.181 | | Sunmodo Sunturf A3 v7 85x45.r3d |

(Global) Model Settings

| | |
|--|--|
| Display Sections for Member Calcs | 5 |
| Max Internal Sections for Member Calcs | 100 |
| Mesh Size (in) | 12 |
| Max Iterations | 10 |
| Merge Tolerance (in) | .12 |
| Solver | Sparse Accelerated |
| Coefficient of Friction | .3 |
| | |
| No. of Shear Regions | 4 |
| Shear Region Spacing Increment (in) | 4 |
| Min 1 Bar Dia Spacing for Beams? | No |
| Optimize footings for OTM / Sliding? | Yes |
| Parame Beta Factor | .65 |
| Pile Safety Factor | 3 |
| Concrete Stress Block | 0 |
| Concrete Rebar Set | Rectangular |
| Concrete Code | ASTM A615 |
| HR Steel Pile Code | ACI 318-14 |
| Wood Pile Code | AISC 14th (360-10): ASD AWC NDS-15: ASD |

Concrete Properties

| | Label | E [ksi] | G [ksi] | Nu | Therm (/... | Density[lb/ft^3] | fc[psi] | Lambda | Flex Stee... | Shear St... |
|---|------------|---------|---------|-----|-------------|------------------|---------|--------|--------------|-------------|
| 1 | Conc3000NW | 3156 | 1372 | .15 | .6 | 145 | 3000 | 1 | 60000 | 60000 |
| 2 | Conc3500NW | 3409 | 1482 | .15 | .6 | 145 | 3500 | 1 | 60000 | 60000 |
| 3 | Conc4000NW | 3644 | 1584 | .15 | .6 | 145 | 4000 | 1 | 60000 | 60000 |
| 4 | Conc3000LW | 2085 | 907 | .15 | .6 | 109.999 | 3000 | .75 | 60000 | 60000 |
| 5 | Conc3500LW | 2252 | 979 | .15 | .6 | 109.999 | 3500 | .75 | 60000 | 60000 |
| 6 | Conc4000LW | 2408 | 1047 | .15 | .6 | 109.999 | 4000 | .75 | 60000 | 60000 |
| 7 | Conc2500NW | 3156 | 1372 | .15 | .6 | 145 | 2500 | 1 | 60000 | 60000 |

General Design Parameters

| | Label | Max Bending Chk | Max Shear Chk | Top Cover[in] | Bottom Cover[in] |
|---|---------|-----------------|---------------|---------------|------------------|
| 1 | Typical | 1 | 1 | 3 | 3 |

Slab Rebar Parameters

| | Label | Top Bar | Bottom Bar | Max Top Bar Sp... | Min Top Bar Sp... | Max Bot Bar Sp... | Min Bot Bar Sp... | Spacing Incr... | Rebar Options |
|---|---------|---------|------------|-------------------|-------------------|-------------------|-------------------|-----------------|---------------|
| 1 | Typical | #5 | #5 | 5 | 5 | 5 | 5 | 1 | Optimize |

Soil Definitions

| | Label | Subgrade Modulus[lb/ft^3] | Allowable Bearing[psf] | Depth Properties | Default? |
|---|---------|---------------------------|------------------------|------------------|----------|
| 1 | Default | 1e+5 | 1500 | None | Yes |

Point Loads and Moments (Cat 1 : DL)

| | Label | Direction | Magnitude[lb.-ft] |
|---|-----------|-----------|-------------------|
| 1 | R3D_N1 | X | -4.418 |
| 2 | R3D_N1 | Y | 146.428 |
| 3 | R3D_N2 | X | -3.936 |
| 4 | R3D_N2 | Y | 118.264 |
| 5 | R3D_N132 | Y | 179.984 |
| 6 | R3D_N133 | Y | 161.334 |
| 7 | R3D_N109 | Y | 190.932 |
| 8 | R3D_N110A | X | 1.274 |

Point Loads and Moments (Cat 1 : DL) (Continued)

| | Label | Direction | Magnitude[lb,lb-ft] |
|----|------------|-----------|---------------------|
| 9 | R3D_N110A | Y | 172.925 |
| 10 | R3D_N121 | Y | 179.937 |
| 11 | R3D_N122 | Y | 161.721 |
| 12 | R3D_N133B | Y | 183.222 |
| 13 | R3D_N134B | Y | 164.134 |
| 14 | R3D_N151 | Y | 183 |
| 15 | R3D_N152 | Y | 163.945 |
| 16 | R3D_N157A | Y | 180.078 |
| 17 | R3D_N158A | Y | 161.84 |
| 18 | R3D_N157_1 | X | 4.424 |
| 19 | R3D_N157_1 | Y | 146.187 |
| 20 | R3D_N158_1 | X | 3.915 |
| 21 | R3D_N158_1 | Y | 118.019 |
| 22 | R3D_N149 | Y | 191.083 |
| 23 | R3D_N150 | X | -1.312 |
| 24 | R3D_N150 | Y | 173.101 |

Point Loads and Moments (Cat 6 : RLL)

| | Label | Direction | Magnitude[lb,lb-ft] |
|----|------------|-----------|---------------------|
| 1 | R3D_N1 | X | -20.664 |
| 2 | R3D_N1 | Y | 515.55 |
| 3 | R3D_N2 | X | -20.031 |
| 4 | R3D_N2 | Y | 475.891 |
| 5 | R3D_N132 | Y | 714.556 |
| 6 | R3D_N133 | Y | 688.759 |
| 7 | R3D_N109 | X | 1.83 |
| 8 | R3D_N109 | Y | 756.671 |
| 9 | R3D_N110A | X | 6.618 |
| 10 | R3D_N110A | Y | 748.383 |
| 11 | R3D_N121 | Y | 716.698 |
| 12 | R3D_N122 | X | 1.023 |
| 13 | R3D_N122 | Y | 690.987 |
| 14 | R3D_N133B | Y | 731.219 |
| 15 | R3D_N134B | X | -1.342 |
| 16 | R3D_N134B | Y | 703.149 |
| 17 | R3D_N151 | Y | 730.081 |
| 18 | R3D_N152 | X | 1.384 |
| 19 | R3D_N152 | Y | 702.256 |
| 20 | R3D_N157A | Y | 717.456 |
| 21 | R3D_N158A | Y | 691.568 |
| 22 | R3D_N157_1 | X | 20.705 |
| 23 | R3D_N157_1 | Y | 514.859 |
| 24 | R3D_N158_1 | X | 19.907 |
| 25 | R3D_N158_1 | Y | 475.089 |
| 26 | R3D_N149 | X | -1.911 |
| 27 | R3D_N149 | Y | 757.239 |
| 28 | R3D_N150 | X | -6.788 |
| 29 | R3D_N150 | Y | 749.229 |

Point Loads and Moments (Cat 16 : OL1)

| | Label | Direction | Magnitude[lb,lb-ft] |
|---|--------|-----------|---------------------|
| 1 | R3D_N1 | X | 56.493 |
| 2 | R3D_N1 | Y | -2721.545 |
| 3 | R3D_N1 | Z | 1566.346 |
| 4 | R3D_N2 | X | 35.136 |
| 5 | R3D_N2 | Y | 477.959 |

Point Loads and Moments (Cat 16 : OL1) (Continued)

| | Label | Direction | Magnitude[lb,lb-ft] |
|----|------------|-----------|---------------------|
| 6 | R3D_N2 | Z | -84.105 |
| 7 | R3D_N132 | Y | -3844.53 |
| 8 | R3D_N132 | Z | 2272.254 |
| 9 | R3D_N133 | Y | 696.801 |
| 10 | R3D_N133 | Z | -104.534 |
| 11 | R3D_N109 | X | -5.181 |
| 12 | R3D_N109 | Y | -4192.119 |
| 13 | R3D_N109 | Z | 2539.373 |
| 14 | R3D_N110A | X | -8.817 |
| 15 | R3D_N110A | Y | 833.256 |
| 16 | R3D_N110A | Z | -102.403 |
| 17 | R3D_N121 | X | -1.783 |
| 18 | R3D_N121 | Y | -3919.982 |
| 19 | R3D_N121 | Z | 2315.433 |
| 20 | R3D_N122 | X | 2.159 |
| 21 | R3D_N122 | Y | 761.643 |
| 22 | R3D_N122 | Z | -104.781 |
| 23 | R3D_N133B | Y | -4019.695 |
| 24 | R3D_N133B | Z | 2381.272 |
| 25 | R3D_N134B | X | 4.26 |
| 26 | R3D_N134B | Y | 803.285 |
| 27 | R3D_N134B | Z | -105.941 |
| 28 | R3D_N151 | Y | -4007.543 |
| 29 | R3D_N151 | Z | 2373.728 |
| 30 | R3D_N152 | X | -4.468 |
| 31 | R3D_N152 | Y | 795.616 |
| 32 | R3D_N152 | Z | -105.83 |
| 33 | R3D_N157A | X | 1.544 |
| 34 | R3D_N157A | Y | -3932.628 |
| 35 | R3D_N157A | Z | 2323.938 |
| 36 | R3D_N158A | X | -2.771 |
| 37 | R3D_N158A | Y | 771.247 |
| 38 | R3D_N158A | Z | -104.909 |
| 39 | R3D_N157_1 | X | -56.637 |
| 40 | R3D_N157_1 | Y | -2720.093 |
| 41 | R3D_N157_1 | Z | 1565.784 |
| 42 | R3D_N158_1 | X | -34.708 |
| 43 | R3D_N158_1 | Y | 479.37 |
| 44 | R3D_N158_1 | Z | -84.073 |
| 45 | R3D_N149 | X | 5.402 |
| 46 | R3D_N149 | Y | -4189.258 |
| 47 | R3D_N149 | Z | 2536.41 |
| 48 | R3D_N150 | X | 9.085 |
| 49 | R3D_N150 | Y | 827.816 |
| 50 | R3D_N150 | Z | -102.378 |

Point Loads and Moments (Cat 17 : OL2)

| | Label | Direction | Magnitude[lb,lb-ft] |
|---|----------|-----------|---------------------|
| 1 | R3D_N1 | X | 72.281 |
| 2 | R3D_N1 | Y | -3036.737 |
| 3 | R3D_N1 | Z | 1322.731 |
| 4 | R3D_N2 | X | 5.008 |
| 5 | R3D_N2 | Y | 1118.444 |
| 6 | R3D_N2 | Z | -70.924 |
| 7 | R3D_N132 | Y | -4258.487 |
| 8 | R3D_N132 | Z | 1893.38 |

Point Loads and Moments (Cat 17 : OL2) (Continued)

| | Label | Direction | Magnitude[lb.-lb-ft] |
|----|------------|-----------|----------------------|
| 9 | R3D_N133 | Y | 1607.733 |
| 10 | R3D_N133 | Z | -87.691 |
| 11 | R3D_N109 | X | -6.696 |
| 12 | R3D_N109 | Y | -4641.852 |
| 13 | R3D_N109 | Z | 2128.153 |
| 14 | R3D_N110A | X | 2.467 |
| 15 | R3D_N110A | Y | 1842.766 |
| 16 | R3D_N110A | Z | -85.99 |
| 17 | R3D_N121 | X | -2.139 |
| 18 | R3D_N121 | Y | -4351.137 |
| 19 | R3D_N121 | Z | 1952.293 |
| 20 | R3D_N122 | X | 4.433 |
| 21 | R3D_N122 | Y | 1692.773 |
| 22 | R3D_N122 | Z | -88.283 |
| 23 | R3D_N133B | X | 1.047 |
| 24 | R3D_N133B | Y | -4473.282 |
| 25 | R3D_N133B | Z | 2016.906 |
| 26 | R3D_N134B | X | 2.725 |
| 27 | R3D_N134B | Y | 1766.862 |
| 28 | R3D_N134B | Z | -89.355 |
| 29 | R3D_N151 | Y | -4458.6 |
| 30 | R3D_N151 | Z | 2008.334 |
| 31 | R3D_N152 | X | -2.894 |
| 32 | R3D_N152 | Y | 1755.735 |
| 33 | R3D_N152 | Z | -89.229 |
| 34 | R3D_N157A | X | 1.839 |
| 35 | R3D_N157A | Y | -4366.578 |
| 36 | R3D_N157A | Z | 1962.232 |
| 37 | R3D_N158A | X | -4.51 |
| 38 | R3D_N158A | Y | 1705.784 |
| 39 | R3D_N158A | Z | -88.431 |
| 40 | R3D_N157_1 | X | -72.453 |
| 41 | R3D_N157_1 | Y | -3034.519 |
| 42 | R3D_N157_1 | Z | 1322.658 |
| 43 | R3D_N158_1 | X | -4.755 |
| 44 | R3D_N158_1 | Y | 1118.427 |
| 45 | R3D_N158_1 | Z | -70.899 |
| 46 | R3D_N149 | X | 6.966 |
| 47 | R3D_N149 | Y | -4637.77 |
| 48 | R3D_N149 | Z | 2123.991 |
| 49 | R3D_N150 | X | -2.442 |
| 50 | R3D_N150 | Y | 1836.872 |
| 51 | R3D_N150 | Z | -85.95 |

Point Loads and Moments (Cat 18 : OL3)

| | Label | Direction | Magnitude[lb.-lb-ft] |
|----|----------|-----------|----------------------|
| 1 | R3D_N1 | X | -67.845 |
| 2 | R3D_N1 | Y | 3252.638 |
| 3 | R3D_N1 | Z | -1856.915 |
| 4 | R3D_N2 | X | -40.778 |
| 5 | R3D_N2 | Y | -592.01 |
| 6 | R3D_N2 | Z | 99.703 |
| 7 | R3D_N132 | Y | 4593.656 |
| 8 | R3D_N132 | Z | -2692.869 |
| 9 | R3D_N133 | Y | -862.262 |
| 10 | R3D_N133 | Z | 123.905 |



Point Loads and Moments (Cat 18 : OL3) (Continued)

| | Label | Direction | Magnitude[lb.-ft] |
|----|------------|-----------|-------------------|
| 11 | R3D_N109 | X | 6.225 |
| 12 | R3D_N109 | Y | 5008.915 |
| 13 | R3D_N109 | Z | -3009.868 |
| 14 | R3D_N110A | X | 10.101 |
| 15 | R3D_N110A | Y | -1028.285 |
| 16 | R3D_N110A | Z | 121.382 |
| 17 | R3D_N121 | X | 2.137 |
| 18 | R3D_N121 | Y | 4684.131 |
| 19 | R3D_N121 | Z | -2744.856 |
| 20 | R3D_N122 | X | -2.652 |
| 21 | R3D_N122 | Y | -940.209 |
| 22 | R3D_N122 | Z | 124.211 |
| 23 | R3D_N133B | X | -1.029 |
| 24 | R3D_N133B | Y | 4803.69 |
| 25 | R3D_N133B | Z | -2823.228 |
| 26 | R3D_N134B | X | -5.019 |
| 27 | R3D_N134B | Y | -990.958 |
| 28 | R3D_N134B | Z | 125.59 |
| 29 | R3D_N151 | Y | 4789.126 |
| 30 | R3D_N151 | Z | -2814.207 |
| 31 | R3D_N152 | X | 5.265 |
| 32 | R3D_N152 | Y | -981.701 |
| 33 | R3D_N152 | Z | 125.457 |
| 34 | R3D_N157A | X | -1.85 |
| 35 | R3D_N157A | Y | 4699.293 |
| 36 | R3D_N157A | Z | -2755.036 |
| 37 | R3D_N158A | X | 3.362 |
| 38 | R3D_N158A | Y | -951.768 |
| 39 | R3D_N158A | Z | 124.364 |
| 40 | R3D_N157_1 | X | 68.018 |
| 41 | R3D_N157_1 | Y | 3250.881 |
| 42 | R3D_N157_1 | Z | -1856.263 |
| 43 | R3D_N158_1 | X | 40.275 |
| 44 | R3D_N158_1 | Y | -593.64 |
| 45 | R3D_N158_1 | Z | 99.666 |
| 46 | R3D_N149 | X | -6.489 |
| 47 | R3D_N149 | Y | 5005.464 |
| 48 | R3D_N149 | Z | -3006.297 |
| 49 | R3D_N150 | X | -10.411 |
| 50 | R3D_N150 | Y | -1021.79 |
| 51 | R3D_N150 | Z | 121.352 |

Point Loads and Moments (Cat 19 : OL4)

| | Label | Direction | Magnitude[lb.-ft] |
|----|----------|-----------|-------------------|
| 1 | R3D_N1 | X | -36.95 |
| 2 | R3D_N1 | Y | 2161.364 |
| 3 | R3D_N1 | Z | -1607.79 |
| 4 | R3D_N2 | X | -57.179 |
| 5 | R3D_N2 | Y | 121.336 |
| 6 | R3D_N2 | Z | 86.416 |
| 7 | R3D_N132 | Y | 3079.991 |
| 8 | R3D_N132 | Z | -2354.178 |
| 9 | R3D_N133 | Y | 157.365 |
| 10 | R3D_N133 | Z | 107.8 |
| 11 | R3D_N109 | X | 3.332 |
| 12 | R3D_N109 | Y | 3359.869 |

Point Loads and Moments (Cat 19 : OL4) (Continued)

| | Label | Direction | Magnitude[lb.-ft] |
|----|------------|-----------|-------------------|
| 13 | R3D_N109 | Z | -2620.49 |
| 14 | R3D_N110A | X | 17.537 |
| 15 | R3D_N110A | Y | 119.858 |
| 16 | R3D_N110A | Z | 105.529 |
| 17 | R3D_N121 | X | 1.289 |
| 18 | R3D_N121 | Y | 3132.669 |
| 19 | R3D_N121 | Z | -2379.282 |
| 20 | R3D_N122 | Y | 116.731 |
| 21 | R3D_N122 | Z | 107.725 |
| 22 | R3D_N133B | Y | 3202.542 |
| 23 | R3D_N133B | Z | -2439.146 |
| 24 | R3D_N134B | X | -5.119 |
| 25 | R3D_N134B | Y | 107.31 |
| 26 | R3D_N134B | Z | 108.837 |
| 27 | R3D_N151 | Y | 3193.852 |
| 28 | R3D_N151 | Z | -2433.286 |
| 29 | R3D_N152 | X | 5.338 |
| 30 | R3D_N152 | Y | 111.199 |
| 31 | R3D_N152 | Z | 108.751 |
| 32 | R3D_N157A | X | -1.127 |
| 33 | R3D_N157A | Y | 3141.575 |
| 34 | R3D_N157A | Z | -2385.651 |
| 35 | R3D_N158A | Y | 111.069 |
| 36 | R3D_N158A | Z | 107.822 |
| 37 | R3D_N157_1 | X | 37.055 |
| 38 | R3D_N157_1 | Y | 2160.722 |
| 39 | R3D_N157_1 | Z | -1606.87 |
| 40 | R3D_N158_1 | X | 56.647 |
| 41 | R3D_N158_1 | Y | 118.852 |
| 42 | R3D_N158_1 | Z | 86.382 |
| 43 | R3D_N149 | X | -3.486 |
| 44 | R3D_N149 | Y | 3358.358 |
| 45 | R3D_N149 | Z | -2618.87 |
| 46 | R3D_N150 | X | -17.983 |
| 47 | R3D_N150 | Y | 124.328 |
| 48 | R3D_N150 | Z | 105.519 |

Point Loads and Moments (Cat 20 : OL5)

| | Label | Direction | Magnitude[lb.-ft] |
|----|-----------|-----------|-------------------|
| 1 | R3D_N1 | X | -21.105 |
| 2 | R3D_N1 | Y | 1222.482 |
| 3 | R3D_N1 | Z | -708.58 |
| 4 | R3D_N2 | X | -18.643 |
| 5 | R3D_N2 | Y | -211.46 |
| 6 | R3D_N2 | Z | 35.196 |
| 7 | R3D_N132 | Y | 612.971 |
| 8 | R3D_N132 | Z | -368.126 |
| 9 | R3D_N133 | Y | -120.242 |
| 10 | R3D_N133 | Z | 20.232 |
| 11 | R3D_N109 | X | 3.656 |
| 12 | R3D_N109 | Y | 1694.322 |
| 13 | R3D_N109 | Z | -1018.314 |
| 14 | R3D_N110A | X | 7.501 |
| 15 | R3D_N110A | Y | -348.041 |
| 16 | R3D_N110A | Z | 39.22 |
| 17 | R3D_N121 | Y | 1313.627 |

Point Loads and Moments (Cat 20 : OL5) (Continued)

| | Label | Direction | Magnitude[lb,lb-ft] |
|----|------------|-----------|---------------------|
| 18 | R3D_N121 | Z | -770.572 |
| 19 | R3D_N122 | Y | -266.099 |
| 20 | R3D_N122 | Z | 34.014 |
| 21 | R3D_N133B | X | 1.967 |
| 22 | R3D_N133B | Y | 1018.363 |
| 23 | R3D_N133B | Z | -599.766 |
| 24 | R3D_N134B | X | 4.523 |
| 25 | R3D_N134B | Y | -193.318 |
| 26 | R3D_N134B | Z | 27.072 |
| 27 | R3D_N151 | Y | 670.563 |
| 28 | R3D_N151 | Z | -396.163 |
| 29 | R3D_N152 | X | 1.62 |
| 30 | R3D_N152 | Y | -128.026 |
| 31 | R3D_N152 | Z | 18.468 |
| 32 | R3D_N157A | Y | 655.654 |
| 33 | R3D_N157A | Z | -387.193 |
| 34 | R3D_N158A | Y | -128.952 |
| 35 | R3D_N158A | Z | 17.734 |
| 36 | R3D_N157_1 | X | 13.906 |
| 37 | R3D_N157_1 | Y | 464.025 |
| 38 | R3D_N157_1 | Z | -260.034 |
| 39 | R3D_N158_1 | X | 6.518 |
| 40 | R3D_N158_1 | Y | -80.198 |
| 41 | R3D_N158_1 | Z | 14.024 |
| 42 | R3D_N149 | Y | 688.976 |
| 43 | R3D_N149 | Z | -424.06 |
| 44 | R3D_N150 | Y | -138.406 |
| 45 | R3D_N150 | Z | 17.159 |

Point Loads and Moments (Cat 21 : OL6)

| | Label | Direction | Magnitude[lb,lb-ft] |
|----|-----------|-----------|---------------------|
| 1 | R3D_N1 | X | 21.623 |
| 2 | R3D_N1 | Y | -1233.255 |
| 3 | R3D_N1 | Z | 713.781 |
| 4 | R3D_N2 | X | 19.012 |
| 5 | R3D_N2 | Y | 215.411 |
| 6 | R3D_N2 | Z | -34.363 |
| 7 | R3D_N132 | Y | -619.526 |
| 8 | R3D_N132 | Z | 370.514 |
| 9 | R3D_N133 | Y | 119.131 |
| 10 | R3D_N133 | Z | -19.399 |
| 11 | R3D_N109 | X | -4.147 |
| 12 | R3D_N109 | Y | -1615.084 |
| 13 | R3D_N109 | Z | 967.745 |
| 14 | R3D_N110A | X | -8.906 |
| 15 | R3D_N110A | Y | 330.107 |
| 16 | R3D_N110A | Z | -36.813 |
| 17 | R3D_N121 | Y | -1073.761 |
| 18 | R3D_N121 | Z | 633.697 |
| 19 | R3D_N122 | X | 1.279 |
| 20 | R3D_N122 | Y | 225.282 |
| 21 | R3D_N122 | Z | -29.968 |
| 22 | R3D_N133B | X | -1.592 |
| 23 | R3D_N133B | Y | -904.868 |
| 24 | R3D_N133B | Z | 532.332 |
| 25 | R3D_N134B | X | -3.534 |



Point Loads and Moments (Cat 21 : OL6) (Continued)

| | Label | Direction | Magnitude[lb.-ft] |
|----|------------|-----------|-------------------|
| 26 | R3D_N134B | Y | 169.588 |
| 27 | R3D_N134B | Z | -24.354 |
| 28 | R3D_N151 | Y | -670.668 |
| 29 | R3D_N151 | Z | 396.624 |
| 30 | R3D_N152 | X | -1.57 |
| 31 | R3D_N152 | Y | 129.759 |
| 32 | R3D_N152 | Z | -18.233 |
| 33 | R3D_N157A | Y | -655.736 |
| 34 | R3D_N157A | Z | 386.971 |
| 35 | R3D_N158A | X | -1.009 |
| 36 | R3D_N158A | Y | 128.583 |
| 37 | R3D_N158A | Z | -17.661 |
| 38 | R3D_N157_1 | X | -14.232 |
| 39 | R3D_N157_1 | Y | -464.79 |
| 40 | R3D_N157_1 | Z | 260.024 |
| 41 | R3D_N158_1 | X | -6.526 |
| 42 | R3D_N158_1 | Y | 80.168 |
| 43 | R3D_N158_1 | Z | -14.015 |
| 44 | R3D_N149 | Y | -688.206 |
| 45 | R3D_N149 | Z | 424.063 |
| 46 | R3D_N150 | Y | 138.494 |
| 47 | R3D_N150 | Z | -17.136 |

Slabs

| | Label | Thickness [in] | Material | Local Axis Angle ... | Analysis Offset [in] | Passive Pressur... | Soil Overburden [psf] |
|---|-------|----------------|------------|----------------------|----------------------|--------------------|-----------------------|
| 1 | S1 | 30 | Conc2500NW | 0 | 0 | 0 | 0 |
| 2 | S2 | 30 | Conc2500NW | 0 | 0 | 0 | 0 |
| 3 | S3 | 30 | Conc2500NW | 0 | 0 | 0 | 0 |
| 4 | S4 | 30 | Conc2500NW | 0 | 0 | 0 | 0 |
| 5 | S5 | 30 | Conc2500NW | 0 | 0 | 0 | 0 |
| 6 | S6 | 30 | Conc2500NW | 0 | 0 | 0 | 0 |
| 7 | S7 | 30 | Conc2500NW | 0 | 0 | 0 | 0 |
| 8 | S8 | 30 | Conc2500NW | 0 | 0 | 0 | 0 |
| 9 | S9 | 30 | Conc2500NW | 0 | 0 | 0 | 0 |

Load Combinations

| Label | Solve | Service A... | SF | Cat... | Fa... | Cat... | Fa... | Cat... | Fa... | Cat... | Fa... | Cat... | Fa... | C... | F... | C... | F... |
|-------|---------------|--------------|-----|--------|-------|--------|-------|--------|-------|--------|-------|--------|-------|------|------|------|------|
| 1 | 1.0 D | Yes | Yes | 1.5 | DL | 1 | | | | | | | | | | | |
| 2 | 1.0 D + 1.... | Yes | Yes | 1.5 | DL | 1 | RLL | 1 | | | | | | | | | |
| 3 | 1.0 D + 0.... | Yes | Yes | 1.5 | DL | 1 | RLL | | OL1 | .6 | | | | | | | |
| 4 | 1.0 D + 0.... | Yes | Yes | 1.5 | DL | 1 | RLL | | OL2 | .6 | | | | | | | |
| 5 | 1.0 D + 0.... | Yes | Yes | 1.5 | DL | 1 | RLL | | OL3 | .6 | | | | | | | |
| 6 | 1.0 D + 0.... | Yes | Yes | 1.5 | DL | 1 | RLL | | OL4 | .6 | | | | | | | |
| 7 | 1.0 D + 0.... | Yes | Yes | 1.5 | DL | 1 | RLL | | OL5 | .6 | | | | | | | |
| 8 | 1.0 D + 0.... | Yes | Yes | 1.5 | DL | 1 | RLL | | OL6 | .6 | | | | | | | |
| 9 | 1.0 D + 0.... | Yes | Yes | 1.5 | DL | 1 | RLL | .75 | OL1 | .45 | | | | | | | |
| 10 | 1.0 D + 0.... | Yes | Yes | 1.5 | DL | 1 | RLL | .75 | OL2 | .45 | | | | | | | |
| 11 | 1.0 D + 0.... | Yes | Yes | 1.5 | DL | 1 | RLL | .75 | OL3 | .45 | | | | | | | |
| 12 | 1.0 D + 0.... | Yes | Yes | 1.5 | DL | 1 | RLL | .75 | OL4 | .45 | | | | | | | |
| 13 | 1.0 D + 0.... | Yes | Yes | 1.5 | DL | 1 | RLL | .75 | OL5 | .45 | | | | | | | |
| 14 | 1.0 D + 0.... | Yes | Yes | 1.5 | DL | 1 | RLL | .75 | OL6 | .45 | | | | | | | |
| 15 | 0.9 D + 0.... | Yes | Yes | | DL | .9 | RLL | | OL1 | .6 | | | | | | | |
| 16 | 0.9 D + 0.... | Yes | Yes | | DL | .9 | RLL | | OL2 | .6 | | | | | | | |
| 17 | 0.9 D + 0.... | Yes | Yes | | DL | .9 | RLL | | OL3 | .6 | | | | | | | |
| 18 | 0.9 D + 0.... | Yes | Yes | | DL | .9 | RLL | | OL4 | .6 | | | | | | | |
| 19 | 0.9 D + 0.... | Yes | Yes | | DL | .9 | RLL | | OL5 | .6 | | | | | | | |

Load Combinations (Continued)

| Label | Solve | Service A | SF | Cat..Fa... | Cat..Fa... | Cat..Fa... | Cat..Fa... | Cat..Fa... | Cat..Fa... | Cat..Fa... | Cat..Fa... | Cat..Fa... | Cat..Fa... | Cat..Fa... | Cat..Fa... | Cat..Fa... | Cat..Fa... | Cat..Fa... |
|-------|--------------|-----------|-----|------------|------------|------------|------------|------------|------------|------------|------------|------------|------------|------------|------------|------------|------------|------------|
| 20 | 0.9D+0... | Yes | Yes | | DL .9 | RLL | | OL6 .6 | | | | | | | | | | |
| 21 | | | | | | | | | | | | | | | | | | |
| 22 | 1.4D | Yes | | | DL 1.4 | | | | | | | | | | | | | |
| 23 | 1.2D+1.6SL | Yes | | | DL 1.2 | RLL 1.6 | | | | | | | | | | | | |
| 24 | 1.2D+1.6S... | Yes | | | DL 1.2 | RLL 1.6 | OL1 .5 | | | | | | | | | | | |
| 25 | 1.2D+1.6S... | Yes | | | DL 1.2 | RLL 1.6 | OL2 .5 | | | | | | | | | | | |
| 26 | 1.2D+1.6S... | Yes | | | DL 1.2 | RLL 1.6 | OL3 .5 | | | | | | | | | | | |
| 27 | 1.2D+1.6S... | Yes | | | DL 1.2 | RLL 1.6 | OL4 .5 | | | | | | | | | | | |
| 28 | 1.2D+1.6S... | Yes | | | DL 1.2 | RLL 1.6 | OL5 .5 | | | | | | | | | | | |
| 29 | 1.2D+1.6S... | Yes | | | DL 1.2 | RLL 1.6 | OL6 .5 | | | | | | | | | | | |
| 30 | 1.2D+1.0... | Yes | | | DL 1.2 | | OL1 1 | | | | | | | | | | | |
| 31 | 1.2D-1.0Wx | Yes | | | DL 1.2 | | OL2 1 | | | | | | | | | | | |
| 32 | 1.2D+1.0... | Yes | | | DL 1.2 | | OL3 1 | | | | | | | | | | | |
| 33 | 1.2D-1.0Wz | Yes | | | DL 1.2 | | OL4 1 | | | | | | | | | | | |
| 34 | 1.2D+1.0... | Yes | | | DL 1.2 | | OL5 1 | | | | | | | | | | | |
| 35 | 1.2D-1.0... | Yes | | | DL 1.2 | | OL6 1 | | | | | | | | | | | |
| 36 | 1.0D+1.0... | Yes | | | DL 1 | | OL1 1 | | | | | | | | | | | |
| 37 | 1.0D-1.0Wx | Yes | | | DL 1 | | OL2 1 | | | | | | | | | | | |
| 38 | 1.0D+1.0... | Yes | | | DL 1 | | OL3 1 | | | | | | | | | | | |
| 39 | 1.0D-1.0Wz | Yes | | | DL 1 | | OL4 1 | | | | | | | | | | | |
| 40 | 1.0D+1.0... | Yes | | | DL 1 | | OL5 1 | | | | | | | | | | | |
| 41 | 1.0D-1.0... | Yes | | | DL 1 | | OL6 1 | | | | | | | | | | | |

Design Strips

| | Label | Rebar Angle from PI... | No. of Design Cuts | Design Rule |
|---|-------|------------------------|--------------------|-------------|
| 1 | DS1 | 0 | 50 | Typical |
| 2 | DS2 | 90 | 50 | Typical |

Load Categories

| | Category | Point Loads | Line Loads | Area Loads |
|---|----------|-------------|------------|------------|
| 1 | DL | 24 | | |
| 2 | RLL | 29 | | |
| 3 | OL1 | 50 | | |
| 4 | OL2 | 51 | | |
| 5 | OL3 | 51 | | |
| 6 | OL4 | 48 | | |
| 7 | OL5 | 45 | | |
| 8 | OL6 | 47 | | |

Strip Reinforcing

| Label | UC Top | LC | Top Bars | Governing ... | UC Bot | LC | Bot B... | Gover... | UC Shear | LC | Governing De... | |
|-------|--------|------|----------|---------------|---------|------|----------|----------|----------|------|-----------------|---------|
| 1 | DS1 | .011 | 26 | #5@5in | DS1-X25 | .02 | 37 | #5@5in | DS1-... | .037 | 37 | DS1-X15 |
| 2 | DS2 | .001 | 36 | #5@5in | DS2-X26 | .002 | 26 | #5@5in | DS2-... | .005 | 26 | DS2-X43 |

Slab Overturning Safety Factors

| LC | Slab | Angle[deg] | Mo-xx[lb-ft] | Ms-xx[lb-ft] | Mo-zz[lb-ft] | Ms-zz[lb-ft] | Ms-xx/Mo-xx | Ms-zz/Mo-zz |
|----|------|------------|--------------|--------------|--------------|--------------|-------------|-------------|
| 1 | S1 | 0 | 0 | 44275.823 | 0 | 11396.69 | 9.999+ | 9.999+ |
| 2 | S2 | 0 | 0 | 44799.78 | 0 | 11496.578 | 9.999+ | 9.999+ |
| 3 | S3 | 0 | 0 | 44689.885 | 0 | 11472.013 | 9.999+ | 9.999+ |
| 4 | S4 | 0 | 0 | 44714.772 | 0 | 11479.135 | 9.999+ | 9.999+ |
| 5 | S5 | 0 | 0 | 44686.663 | 0 | 11471.589 | 9.999+ | 9.999+ |
| 6 | S6 | 0 | 0 | 44712.87 | 0 | 11478.622 | 9.999+ | 9.999+ |
| 7 | S7 | 0 | 0 | 44691.083 | 0 | 11472.338 | 9.999+ | 9.999+ |
| 8 | S8 | 0 | 0 | 44801.474 | 0 | 11503.45 | 9.999+ | 9.999+ |
| 9 | S9 | 0 | 0 | 44273.42 | 0 | 11354.351 | 9.999+ | 9.999+ |



Company : Vector Structural Engineering
 Designer : STB
 Job Number : U2716.091.181
 Model Name : Ground Mount

Apr 12, 2021
 3:08 PM
 Checked By: JSP

Slab Overturning Safety Factors (Continued)

| | LC | Slab | Angle[deg] | Mo-xx[lb-ft] | Ms-xx[lb-ft] | Mo-zz[lb-ft] | Ms-zz[lb-ft] | Ms-xx/Mo-xx | Ms-zz/Mo-zz |
|----|----|------|------------|--------------|--------------|--------------|--------------|-------------|-------------|
| 10 | 2 | S1 | 0 | 0 | 49008.29 | 0 | 12737.73 | 9.999+ | 9.999+ |
| 11 | 2 | S2 | 0 | 0 | 52169.926 | 0 | 13356.777 | 9.999+ | 9.999+ |
| 12 | 2 | S3 | 0 | 0 | 51518.864 | 0 | 13229.061 | 9.999+ | 9.999+ |
| 13 | 2 | S4 | 0 | 0 | 51666.495 | 0 | 13275.451 | 9.999+ | 9.999+ |
| 14 | 2 | S5 | 0 | 0 | 51493.849 | 0 | 13225.732 | 9.999+ | 9.999+ |
| 15 | 2 | S6 | 0 | 0 | 51655.485 | 0 | 13265.583 | 9.999+ | 9.999+ |
| 16 | 2 | S7 | 0 | 0 | 51526.018 | 0 | 13233.619 | 9.999+ | 9.999+ |
| 17 | 2 | S8 | 0 | 0 | 52179.564 | 0 | 13408.282 | 9.999+ | 9.999+ |
| 18 | 2 | S9 | 0 | 0 | 48998.154 | 0 | 12490.257 | 9.999+ | 9.999+ |
| 19 | 3 | S1 | 0 | 15608.722 | 44455.612 | 1820.132 | 11396.69 | 2.848 | 6.261 |
| 20 | 3 | S2 | 0 | 24200.755 | 44898.521 | 2540.146 | 11502.947 | 1.855 | 4.528 |
| 21 | 3 | S3 | 0 | 22540.693 | 44791.969 | 2369.317 | 11472.013 | 1.987 | 4.842 |
| 22 | 3 | S4 | 0 | 23110.034 | 44822.633 | 2418.697 | 11479.135 | 1.94 | 4.746 |
| 23 | 3 | S5 | 0 | 22143.897 | 44791.882 | 2360.797 | 11471.589 | 2.023 | 4.859 |
| 24 | 3 | S6 | 0 | 23043.267 | 44820.532 | 2415.646 | 11478.622 | 1.945 | 4.752 |
| 25 | 3 | S7 | 0 | 22609.922 | 44793.307 | 2372.876 | 11472.338 | 1.981 | 4.835 |
| 26 | 3 | S8 | 0 | 24185.98 | 44900.007 | 2542.811 | 11503.45 | 1.856 | 4.524 |
| 27 | 3 | S9 | 0 | 15599.536 | 44453.277 | 1817.559 | 11396.045 | 2.85 | 6.27 |
| 28 | 4 | S1 | 0 | 16374.424 | 44455.612 | 1554.653 | 11396.69 | 2.715 | 7.331 |
| 29 | 4 | S2 | 0 | 25122.558 | 44898.521 | 2105.658 | 11502.947 | 1.787 | 5.463 |
| 30 | 4 | S3 | 0 | 23499.711 | 44791.969 | 1997.215 | 11472.013 | 1.906 | 5.744 |
| 31 | 4 | S4 | 0 | 24156.289 | 44822.633 | 2035.474 | 11479.135 | 1.856 | 5.64 |
| 32 | 4 | S5 | 0 | 23008.128 | 44791.882 | 1988.066 | 11471.589 | 1.947 | 5.77 |
| 33 | 4 | S6 | 0 | 24077.821 | 44820.532 | 2031.491 | 11478.622 | 1.861 | 5.65 |
| 34 | 4 | S7 | 0 | 23582.616 | 44793.307 | 1999.602 | 11472.338 | 1.899 | 5.737 |
| 35 | 4 | S8 | 0 | 25100.183 | 44900.007 | 2107.459 | 11503.45 | 1.789 | 5.458 |
| 36 | 4 | S9 | 0 | 16363.164 | 44453.277 | 1552.881 | 11396.045 | 2.717 | 7.339 |
| 37 | 5 | S1 | 0 | 3052.965 | 44275.823 | 0 | 13555.096 | 9.999+ | 9.999+ |
| 38 | 5 | S2 | 0 | 5569.859 | 44799.78 | 0 | 14457.562 | 8.043 | 9.999+ |
| 39 | 5 | S3 | 0 | 4978.736 | 44689.885 | 0 | 14280.728 | 8.976 | 9.999+ |
| 40 | 5 | S4 | 0 | 5257.398 | 44714.772 | 0 | 14347.755 | 8.505 | 9.999+ |
| 41 | 5 | S5 | 0 | 4576.067 | 44686.663 | 0 | 14270.134 | 9.765 | 9.999+ |
| 42 | 5 | S6 | 0 | 5208.51 | 44712.87 | 0 | 14326.293 | 8.585 | 9.999+ |
| 43 | 5 | S7 | 0 | 5040.601 | 44691.083 | 0 | 14280.713 | 8.866 | 9.999+ |
| 44 | 5 | S8 | 0 | 5534.187 | 44801.474 | 0 | 14516.555 | 8.095 | 9.999+ |
| 45 | 5 | S9 | 0 | 3061.764 | 44273.42 | 0 | 13184.843 | 9.999+ | 9.999+ |
| 46 | 6 | S1 | 0 | 0 | 44341.662 | 0 | 13249.909 | 9.999+ | 9.999+ |
| 47 | 6 | S2 | 0 | 473.279 | 44799.78 | 0 | 14075.07 | 9.999+ | 9.999+ |
| 48 | 6 | S3 | 0 | 305.878 | 44689.885 | 0 | 13907.13 | 9.999+ | 9.999+ |
| 49 | 6 | S4 | 0 | 386.158 | 44714.772 | 0 | 13969.201 | 9.999+ | 9.999+ |
| 50 | 6 | S5 | 0 | 103.022 | 44686.663 | 0 | 13899.606 | 9.999+ | 9.999+ |
| 51 | 6 | S6 | 0 | 364.617 | 44712.87 | 0 | 13949.403 | 9.999+ | 9.999+ |
| 52 | 6 | S7 | 0 | 337.041 | 44691.083 | 0 | 13913.512 | 9.999+ | 9.999+ |
| 53 | 6 | S8 | 0 | 449.274 | 44801.474 | 0 | 14147.67 | 9.999+ | 9.999+ |
| 54 | 6 | S9 | 0 | 0 | 44327.405 | 0 | 12923.478 | 9.999+ | 9.999+ |
| 55 | 7 | S1 | 0 | 1110.54 | 44275.823 | 0 | 12214.579 | 9.999+ | 9.999+ |
| 56 | 7 | S2 | 0 | 1888.198 | 44799.78 | 0 | 12489.554 | 9.999+ | 9.999+ |
| 57 | 7 | S3 | 0 | 1411.041 | 44689.885 | 0 | 12257.659 | 9.999+ | 9.999+ |
| 58 | 7 | S4 | 0 | 1030.277 | 44714.772 | 0 | 12088.183 | 9.999+ | 9.999+ |
| 59 | 7 | S5 | 0 | 644.698 | 44686.663 | 0 | 11841.135 | 9.999+ | 9.999+ |
| 60 | 7 | S6 | 0 | 683.028 | 44712.87 | 0 | 11883.094 | 9.999+ | 9.999+ |
| 61 | 7 | S7 | 0 | 687.323 | 44691.083 | 0 | 11867.364 | 9.999+ | 9.999+ |
| 62 | 7 | S8 | 0 | 765.043 | 44801.474 | 0 | 11916.378 | 9.999+ | 9.999+ |
| 63 | 7 | S9 | 0 | 406.803 | 44273.42 | 0 | 11611.585 | 9.999+ | 9.999+ |
| 64 | 8 | S1 | 0 | 7085.521 | 44455.612 | 824.336 | 11396.69 | 6.274 | 9.999+ |
| 65 | 8 | S2 | 0 | 9305.009 | 44898.521 | 983.313 | 11502.947 | 4.825 | 9.999+ |
| 66 | 8 | S3 | 0 | 6159.136 | 44791.969 | 638.278 | 11472.013 | 7.272 | 9.999+ |



Company : Vector Structural Engineering
 Designer : STB
 Job Number : U2716.091.181
 Model Name : Ground Mount

Apr 12, 2021
 3:08 PM
 Checked By: JSP

Slab Overturning Safety Factors (Continued)

| | LC | Slab | Angle[deg] | Mo-xx[lb-ft] | Ms-xx[lb-ft] | Mo-zz[lb-ft] | Ms-zz[lb-ft] | Ms-xx/Mo-xx | Ms-zz/Mo-zz |
|-----|----|------|------------|--------------|--------------|--------------|--------------|-------------|-------------|
| 67 | 8 | S4 | 0 | 5204.367 | 44822.633 | 559.149 | 11479.135 | 8.613 | 9.999+ |
| 68 | 8 | S5 | 0 | 3565.937 | 44791.882 | 375.296 | 11471.589 | 9.999+ | 9.999+ |
| 69 | 8 | S6 | 0 | 3857.149 | 44820.532 | 408.037 | 11478.622 | 9.999+ | 9.999+ |
| 70 | 8 | S7 | 0 | 3768.999 | 44793.307 | 396.878 | 11472.338 | 9.999+ | 9.999+ |
| 71 | 8 | S8 | 0 | 3981.966 | 44900.007 | 412.284 | 11496.89 | 9.999+ | 9.999+ |
| 72 | 8 | S9 | 0 | 2656.081 | 44453.277 | 319.604 | 11396.045 | 9.999+ | 9.999+ |
| 73 | 9 | S1 | 0 | 11706.542 | 48156.185 | 1365.099 | 12402.47 | 4.114 | 9.085 |
| 74 | 9 | S2 | 0 | 18150.566 | 50376.637 | 1905.109 | 12929.774 | 2.775 | 6.787 |
| 75 | 9 | S3 | 0 | 16905.519 | 49963.944 | 1776.988 | 12789.799 | 2.955 | 7.197 |
| 76 | 9 | S4 | 0 | 17332.526 | 50097.678 | 1814.023 | 12826.372 | 2.89 | 7.071 |
| 77 | 9 | S5 | 0 | 16607.923 | 49948.249 | 1770.598 | 12787.196 | 3.007 | 7.222 |
| 78 | 9 | S6 | 0 | 17282.45 | 50087.556 | 1811.735 | 12824.033 | 2.898 | 7.078 |
| 79 | 9 | S7 | 0 | 16957.442 | 49970.617 | 1779.657 | 12793.299 | 2.947 | 7.189 |
| 80 | 9 | S8 | 0 | 18139.485 | 50382.505 | 1907.108 | 12932.074 | 2.778 | 6.781 |
| 81 | 9 | S9 | 0 | 11699.652 | 48148.738 | 1363.17 | 12400.269 | 4.115 | 9.097 |
| 82 | 10 | S1 | 0 | 12280.818 | 48156.185 | 1165.99 | 12402.47 | 3.921 | 9.999+ |
| 83 | 10 | S2 | 0 | 18841.918 | 50376.637 | 1579.244 | 12929.774 | 2.674 | 8.187 |
| 84 | 10 | S3 | 0 | 17624.783 | 49963.944 | 1497.911 | 12789.799 | 2.835 | 8.538 |
| 85 | 10 | S4 | 0 | 18117.217 | 50097.678 | 1526.605 | 12826.372 | 2.765 | 8.402 |
| 86 | 10 | S5 | 0 | 17256.096 | 49948.249 | 1491.049 | 12787.196 | 2.895 | 8.576 |
| 87 | 10 | S6 | 0 | 18058.366 | 50087.556 | 1523.618 | 12824.033 | 2.774 | 8.417 |
| 88 | 10 | S7 | 0 | 17686.962 | 49970.617 | 1499.702 | 12793.299 | 2.825 | 8.531 |
| 89 | 10 | S8 | 0 | 18825.137 | 50382.505 | 1580.594 | 12932.074 | 2.676 | 8.182 |
| 90 | 10 | S9 | 0 | 12272.373 | 48148.738 | 1164.66 | 12400.269 | 3.923 | 9.999+ |
| 91 | 11 | S1 | 0 | 2289.724 | 47825.173 | 0 | 14021.274 | 9.999+ | 9.999+ |
| 92 | 11 | S2 | 0 | 4177.394 | 50327.39 | 0 | 15112.465 | 9.999+ | 9.999+ |
| 93 | 11 | S3 | 0 | 3734.052 | 49811.619 | 0 | 14896.335 | 9.999+ | 9.999+ |
| 94 | 11 | S4 | 0 | 3943.049 | 49928.564 | 0 | 14977.838 | 9.999+ | 9.999+ |
| 95 | 11 | S5 | 0 | 3432.05 | 49792.052 | 0 | 14886.105 | 9.999+ | 9.999+ |
| 96 | 11 | S6 | 0 | 3906.383 | 49919.832 | 0 | 14954.596 | 9.999+ | 9.999+ |
| 97 | 11 | S7 | 0 | 3780.45 | 49817.284 | 0 | 14899.58 | 9.999+ | 9.999+ |
| 98 | 11 | S8 | 0 | 4150.64 | 50335.042 | 0 | 15191.903 | 9.999+ | 9.999+ |
| 99 | 11 | S9 | 0 | 2296.323 | 47816.97 | 0 | 13579.149 | 9.999+ | 9.999+ |
| 100 | 12 | S1 | 0 | 0 | 47874.553 | 0 | 13792.383 | 9.999+ | 9.999+ |
| 101 | 12 | S2 | 0 | 354.96 | 50327.39 | 0 | 14825.596 | 9.999+ | 9.999+ |
| 102 | 12 | S3 | 0 | 229.409 | 49811.619 | 0 | 14616.136 | 9.999+ | 9.999+ |
| 103 | 12 | S4 | 0 | 289.619 | 49928.564 | 0 | 14693.922 | 9.999+ | 9.999+ |
| 104 | 12 | S5 | 0 | 77.266 | 49792.052 | 0 | 14608.209 | 9.999+ | 9.999+ |
| 105 | 12 | S6 | 0 | 273.462 | 49919.832 | 0 | 14671.929 | 9.999+ | 9.999+ |
| 106 | 12 | S7 | 0 | 252.781 | 49817.284 | 0 | 14624.179 | 9.999+ | 9.999+ |
| 107 | 12 | S8 | 0 | 336.956 | 50335.042 | 0 | 14915.239 | 9.999+ | 9.999+ |
| 108 | 12 | S9 | 0 | 0 | 47857.46 | 0 | 13383.126 | 9.999+ | 9.999+ |
| 109 | 13 | S1 | 0 | 832.905 | 47825.173 | 0 | 13015.886 | 9.999+ | 9.999+ |
| 110 | 13 | S2 | 0 | 1416.149 | 50327.39 | 0 | 13636.459 | 9.999+ | 9.999+ |
| 111 | 13 | S3 | 0 | 1058.281 | 49811.619 | 0 | 13379.034 | 9.999+ | 9.999+ |
| 112 | 13 | S4 | 0 | 772.707 | 49928.564 | 0 | 13283.158 | 9.999+ | 9.999+ |
| 113 | 13 | S5 | 0 | 483.524 | 49792.052 | 0 | 13064.356 | 9.999+ | 9.999+ |
| 114 | 13 | S6 | 0 | 512.271 | 49919.832 | 0 | 13122.197 | 9.999+ | 9.999+ |
| 115 | 13 | S7 | 0 | 515.493 | 49817.284 | 0 | 13089.569 | 9.999+ | 9.999+ |
| 116 | 13 | S8 | 0 | 573.782 | 50335.042 | 0 | 13241.77 | 9.999+ | 9.999+ |
| 117 | 13 | S9 | 0 | 305.102 | 47816.97 | 0 | 12399.206 | 9.999+ | 9.999+ |
| 118 | 14 | S1 | 0 | 5314.141 | 48156.185 | 618.252 | 12402.47 | 9.062 | 9.999+ |
| 119 | 14 | S2 | 0 | 6978.757 | 50376.637 | 737.485 | 12929.774 | 7.219 | 9.999+ |
| 120 | 14 | S3 | 0 | 4619.352 | 49963.944 | 478.709 | 12789.799 | 9.999+ | 9.999+ |
| 121 | 14 | S4 | 0 | 3903.275 | 50097.678 | 419.362 | 12821.338 | 9.999+ | 9.999+ |
| 122 | 14 | S5 | 0 | 2674.453 | 49948.249 | 281.472 | 12787.196 | 9.999+ | 9.999+ |
| 123 | 14 | S6 | 0 | 2892.862 | 50087.556 | 306.028 | 12824.033 | 9.999+ | 9.999+ |



Company : Vector Structural Engineering
 Designer : STB
 Job Number : U2716.091.181
 Model Name : Ground Mount

Apr 12, 2021
 3:08 PM
 Checked By: JSP

Slab Overturning Safety Factors (Continued)

| LC | Slab | Angle[deg] | Mo-xx[lb-ft] | Ms-xx[lb-ft] | Mo-zz[lb-ft] | Ms-zz[lb-ft] | Ms-xx/Mo-xx | Ms-zz/Mo-zz | |
|-----|------|------------|--------------|--------------|--------------|--------------|-------------|-------------|--------|
| 124 | 14 | S7 | 0 | 2826.749 | 49970.617 | 297.659 | 12793.299 | 9.999+ | 9.999+ |
| 125 | 14 | S8 | 0 | 2986.475 | 50382.505 | 309.213 | 12892.894 | 9.999+ | 9.999+ |
| 126 | 14 | S9 | 0 | 1992.061 | 48148.738 | 239.703 | 12400.269 | 9.999+ | 9.999+ |
| 127 | 15 | S1 | 0 | 15608.722 | 40010.051 | 1820.132 | 10257.021 | 2.563 | 5.635 |
| 128 | 15 | S2 | 0 | 24200.755 | 40408.669 | 2540.146 | 10352.652 | 1.67 | 4.076 |
| 129 | 15 | S3 | 0 | 22540.693 | 40312.772 | 2369.317 | 10324.812 | 1.788 | 4.358 |
| 130 | 15 | S4 | 0 | 23110.034 | 40340.37 | 2418.697 | 10331.221 | 1.746 | 4.271 |
| 131 | 15 | S5 | 0 | 22143.897 | 40312.694 | 2360.797 | 10324.43 | 1.82 | 4.373 |
| 132 | 15 | S6 | 0 | 23043.267 | 40338.479 | 2415.646 | 10330.76 | 1.751 | 4.277 |
| 133 | 15 | S7 | 0 | 22609.922 | 40313.976 | 2372.876 | 10325.104 | 1.783 | 4.351 |
| 134 | 15 | S8 | 0 | 24185.98 | 40410.006 | 2542.811 | 10353.105 | 1.671 | 4.072 |
| 135 | 15 | S9 | 0 | 15599.536 | 40007.95 | 1817.559 | 10256.441 | 2.565 | 5.643 |
| 136 | 16 | S1 | 0 | 16374.424 | 40010.051 | 1554.653 | 10257.021 | 2.443 | 6.598 |
| 137 | 16 | S2 | 0 | 25122.558 | 40408.669 | 2105.658 | 10352.652 | 1.608 | 4.917 |
| 138 | 16 | S3 | 0 | 23499.711 | 40312.772 | 1997.215 | 10324.812 | 1.715 | 5.17 |
| 139 | 16 | S4 | 0 | 24156.289 | 40340.37 | 2035.474 | 10331.221 | 1.67 | 5.076 |
| 140 | 16 | S5 | 0 | 23008.128 | 40312.694 | 1988.066 | 10324.43 | 1.752 | 5.193 |
| 141 | 16 | S6 | 0 | 24077.821 | 40338.479 | 2031.491 | 10330.76 | 1.675 | 5.085 |
| 142 | 16 | S7 | 0 | 23582.616 | 40313.976 | 1999.602 | 10325.104 | 1.709 | 5.164 |
| 143 | 16 | S8 | 0 | 25100.183 | 40410.006 | 2107.459 | 10353.105 | 1.61 | 4.913 |
| 144 | 16 | S9 | 0 | 16363.164 | 40007.95 | 1552.881 | 10256.441 | 2.445 | 6.605 |
| 145 | 17 | S1 | 0 | 3052.965 | 39848.24 | 0 | 12415.427 | 9.999+ | 9.999+ |
| 146 | 17 | S2 | 0 | 5569.859 | 40319.802 | 0 | 13307.904 | 7.239 | 9.999+ |
| 147 | 17 | S3 | 0 | 4978.736 | 40220.897 | 0 | 13133.527 | 8.079 | 9.999+ |
| 148 | 17 | S4 | 0 | 5257.398 | 40243.295 | 0 | 13199.842 | 7.655 | 9.999+ |
| 149 | 17 | S5 | 0 | 4576.067 | 40217.996 | 0 | 13122.975 | 8.789 | 9.999+ |
| 150 | 17 | S6 | 0 | 5208.51 | 40241.583 | 0 | 13178.43 | 7.726 | 9.999+ |
| 151 | 17 | S7 | 0 | 5040.601 | 40221.975 | 0 | 13133.479 | 7.98 | 9.999+ |
| 152 | 17 | S8 | 0 | 5534.187 | 40321.327 | 0 | 13366.21 | 7.286 | 9.999+ |
| 153 | 17 | S9 | 0 | 3061.764 | 39846.078 | 0 | 12049.407 | 9.999+ | 9.999+ |
| 154 | 18 | S1 | 0 | 0 | 39914.08 | 0 | 12110.24 | 9.999+ | 9.999+ |
| 155 | 18 | S2 | 0 | 473.279 | 40319.802 | 0 | 12925.412 | 9.999+ | 9.999+ |
| 156 | 18 | S3 | 0 | 305.878 | 40220.897 | 0 | 12759.928 | 9.999+ | 9.999+ |
| 157 | 18 | S4 | 0 | 386.158 | 40243.295 | 0 | 12821.288 | 9.999+ | 9.999+ |
| 158 | 18 | S5 | 0 | 103.022 | 40217.996 | 0 | 12752.447 | 9.999+ | 9.999+ |
| 159 | 18 | S6 | 0 | 364.617 | 40241.583 | 0 | 12801.541 | 9.999+ | 9.999+ |
| 160 | 18 | S7 | 0 | 337.041 | 40221.975 | 0 | 12766.278 | 9.999+ | 9.999+ |
| 161 | 18 | S8 | 0 | 449.274 | 40321.327 | 0 | 12997.325 | 9.999+ | 9.999+ |
| 162 | 18 | S9 | 0 | 0 | 39900.063 | 0 | 11788.043 | 9.999+ | 9.999+ |
| 163 | 19 | S1 | 0 | 1110.54 | 39848.24 | 0 | 11074.91 | 9.999+ | 9.999+ |
| 164 | 19 | S2 | 0 | 1888.198 | 40319.802 | 0 | 11339.896 | 9.999+ | 9.999+ |
| 165 | 19 | S3 | 0 | 1411.041 | 40220.897 | 0 | 11110.458 | 9.999+ | 9.999+ |
| 166 | 19 | S4 | 0 | 1030.277 | 40243.295 | 0 | 10940.27 | 9.999+ | 9.999+ |
| 167 | 19 | S5 | 0 | 644.698 | 40217.996 | 0 | 10693.976 | 9.999+ | 9.999+ |
| 168 | 19 | S6 | 0 | 683.028 | 40241.583 | 0 | 10735.232 | 9.999+ | 9.999+ |
| 169 | 19 | S7 | 0 | 687.323 | 40221.975 | 0 | 10720.131 | 9.999+ | 9.999+ |
| 170 | 19 | S8 | 0 | 765.043 | 40321.327 | 0 | 10766.033 | 9.999+ | 9.999+ |
| 171 | 19 | S9 | 0 | 406.803 | 39846.078 | 0 | 10476.15 | 9.999+ | 9.999+ |
| 172 | 20 | S1 | 0 | 7085.521 | 40010.051 | 824.336 | 10257.021 | 5.647 | 9.999+ |
| 173 | 20 | S2 | 0 | 9305.009 | 40408.669 | 983.313 | 10352.652 | 4.343 | 9.999+ |
| 174 | 20 | S3 | 0 | 6159.136 | 40312.772 | 638.278 | 10324.812 | 6.545 | 9.999+ |
| 175 | 20 | S4 | 0 | 5204.367 | 40340.37 | 559.149 | 10331.221 | 7.751 | 9.999+ |
| 176 | 20 | S5 | 0 | 3565.937 | 40312.694 | 375.296 | 10324.43 | 9.999+ | 9.999+ |
| 177 | 20 | S6 | 0 | 3857.149 | 40338.479 | 408.037 | 10330.76 | 9.999+ | 9.999+ |
| 178 | 20 | S7 | 0 | 3768.999 | 40313.976 | 396.878 | 10325.104 | 9.999+ | 9.999+ |
| 179 | 20 | S8 | 0 | 3981.966 | 40410.006 | 412.284 | 10347.201 | 9.999+ | 9.999+ |
| 180 | 20 | S9 | 0 | 2656.081 | 40007.95 | 319.604 | 10256.441 | 9.999+ | 9.999+ |



Company : Vector Structural Engineering
 Designer : STB
 Job Number : U2716.091.181
 Model Name : Ground Mount

Apr 12, 2021
 3:08 PM
 Checked By: JSP

Slab Sliding Safety Factors

| | LC | Slab | Angle[deg] | Va-xx[lb] | Vr-xx[lb] | Va-zz[lb] | Vr-zz[lb] | SR-xx | SR-zz |
|----|----|------|------------|-----------|-----------|-----------|-----------|--------|--------|
| 1 | 1 | S1 | 0 | 8.354 | 2730.193 | 0 | 2730.193 | 9.999+ | 9.999+ |
| 2 | 1 | S2 | 0 | 1.274 | 2759.943 | 0 | 2759.943 | 9.999+ | 9.999+ |
| 3 | 1 | S3 | 0 | 0 | 2753.283 | 0 | 2753.283 | 9.999+ | 9.999+ |
| 4 | 1 | S4 | 0 | 0 | 2754.992 | 0 | 2754.992 | 9.999+ | 9.999+ |
| 5 | 1 | S5 | 0 | 0 | 2753.181 | 0 | 2753.181 | 9.999+ | 9.999+ |
| 6 | 1 | S6 | 0 | 0 | 2754.869 | 0 | 2754.869 | 9.999+ | 9.999+ |
| 7 | 1 | S7 | 0 | 0 | 2753.361 | 0 | 2753.361 | 9.999+ | 9.999+ |
| 8 | 1 | S8 | 0 | 1.312 | 2760.041 | 0 | 2760.041 | 9.999+ | 9.999+ |
| 9 | 1 | S9 | 0 | 8.339 | 2730.048 | 0 | 2730.048 | 9.999+ | 9.999+ |
| 10 | 2 | S1 | 0 | 49.049 | 3027.626 | 0 | 3027.626 | 9.999+ | 9.999+ |
| 11 | 2 | S2 | 0 | 9.721 | 3211.459 | 0 | 3211.459 | 9.999+ | 9.999+ |
| 12 | 2 | S3 | 0 | 1.023 | 3175.588 | 0 | 3175.588 | 9.999+ | 9.999+ |
| 13 | 2 | S4 | 0 | 1.342 | 3185.303 | 0 | 3185.303 | 9.999+ | 9.999+ |
| 14 | 2 | S5 | 0 | 0 | 3174.176 | 0 | 3174.176 | 9.999+ | 9.999+ |
| 15 | 2 | S6 | 0 | 1.384 | 3184.57 | 0 | 3184.57 | 9.999+ | 9.999+ |
| 16 | 2 | S7 | 0 | 0 | 3176.069 | 0 | 3176.069 | 9.999+ | 9.999+ |
| 17 | 2 | S8 | 0 | 10.011 | 3211.981 | 0 | 3211.981 | 9.999+ | 9.999+ |
| 18 | 2 | S9 | 0 | 48.951 | 3027.032 | 0 | 3027.032 | 9.999+ | 9.999+ |
| 19 | 3 | S1 | 0 | 46.623 | 2326.348 | 889.345 | 2326.348 | 9.999+ | 2.616 |
| 20 | 3 | S2 | 0 | 7.126 | 2155.348 | 1462.182 | 2155.348 | 9.999+ | 1.474 |
| 21 | 3 | S3 | 0 | .225 | 2184.782 | 1326.391 | 2184.782 | 9.999+ | 1.647 |
| 22 | 3 | S4 | 0 | 2.556 | 2176.038 | 1365.198 | 2176.038 | 9.999+ | 1.594 |
| 23 | 3 | S5 | 0 | 0 | 2186.59 | 1300.632 | 2186.59 | 9.999+ | 1.681 |
| 24 | 3 | S6 | 0 | 2.681 | 2176.722 | 1360.739 | 2176.722 | 9.999+ | 1.6 |
| 25 | 3 | S7 | 0 | .736 | 2184.312 | 1331.418 | 2184.312 | 9.999+ | 1.641 |
| 26 | 3 | S8 | 0 | 7.38 | 2154.981 | 1460.42 | 2154.981 | 9.999+ | 1.476 |
| 27 | 3 | S9 | 0 | 46.468 | 2326.717 | 889.027 | 2326.717 | 9.999+ | 2.617 |
| 28 | 4 | S1 | 0 | 38.019 | 2384.901 | 751.084 | 2384.901 | 9.999+ | 3.175 |
| 29 | 4 | S2 | 0 | 1.264 | 2256.107 | 1225.298 | 2256.107 | 9.999+ | 1.841 |
| 30 | 4 | S3 | 0 | 1.377 | 2274.778 | 1118.406 | 2274.778 | 9.999+ | 2.034 |
| 31 | 4 | S4 | 0 | 2.263 | 2267.837 | 1156.53 | 2267.837 | 9.999+ | 1.961 |
| 32 | 4 | S5 | 0 | 0 | 2276.045 | 1083.413 | 2276.045 | 9.999+ | 2.101 |
| 33 | 4 | S6 | 0 | 1.737 | 2268.353 | 1151.463 | 2268.353 | 9.999+ | 1.97 |
| 34 | 4 | S7 | 0 | 1.603 | 2274.418 | 1124.281 | 2274.418 | 9.999+ | 2.023 |
| 35 | 4 | S8 | 0 | 1.402 | 2255.879 | 1222.825 | 2255.879 | 9.999+ | 1.845 |
| 36 | 4 | S9 | 0 | 37.986 | 2385.151 | 751.056 | 2385.151 | 9.999+ | 3.176 |
| 37 | 5 | S1 | 0 | 73.528 | 3209.106 | 1054.327 | 3209.106 | 9.999+ | 3.044 |
| 38 | 5 | S2 | 0 | 11.069 | 3476.456 | 1733.091 | 3476.456 | 9.999+ | 2.006 |
| 39 | 5 | S3 | 0 | .309 | 3427.189 | 1572.387 | 3427.189 | 9.999+ | 2.18 |
| 40 | 5 | S4 | 0 | 3.628 | 3441.284 | 1618.583 | 3441.284 | 9.999+ | 2.126 |
| 41 | 5 | S5 | 0 | 0 | 3424.832 | 1541.379 | 3424.832 | 9.999+ | 2.222 |
| 42 | 5 | S6 | 0 | 3.159 | 3440.206 | 1613.25 | 3440.206 | 9.999+ | 2.132 |
| 43 | 5 | S7 | 0 | .908 | 3427.916 | 1578.403 | 3427.916 | 9.999+ | 2.172 |
| 44 | 5 | S8 | 0 | 11.452 | 3477.102 | 1730.967 | 3477.102 | 9.999+ | 2.009 |
| 45 | 5 | S9 | 0 | 73.315 | 3208.351 | 1053.958 | 3208.351 | 9.999+ | 3.044 |
| 46 | 6 | S1 | 0 | 64.831 | 3141.079 | 912.824 | 3141.079 | 9.999+ | 3.441 |
| 47 | 6 | S2 | 0 | 13.795 | 3386.294 | 1508.977 | 3386.294 | 9.999+ | 2.244 |
| 48 | 6 | S3 | 0 | .773 | 3338.175 | 1362.934 | 3338.175 | 9.999+ | 2.449 |
| 49 | 6 | S4 | 0 | 3.071 | 3350.766 | 1398.185 | 3350.766 | 9.999+ | 2.397 |
| 50 | 6 | S5 | 0 | 0 | 3335.905 | 1347.827 | 3335.905 | 9.999+ | 2.475 |
| 51 | 6 | S6 | 0 | 3.203 | 3349.778 | 1394.721 | 3349.778 | 9.999+ | 2.402 |
| 52 | 6 | S7 | 0 | .676 | 3338.837 | 1366.697 | 3338.837 | 9.999+ | 2.443 |
| 53 | 6 | S8 | 0 | 14.194 | 3386.924 | 1508.011 | 3386.924 | 9.999+ | 2.246 |
| 54 | 6 | S9 | 0 | 64.56 | 3140.371 | 912.292 | 3140.371 | 9.999+ | 3.442 |
| 55 | 7 | S1 | 0 | 32.203 | 2912.177 | 404.031 | 2912.177 | 9.999+ | 7.208 |
| 56 | 7 | S2 | 0 | 7.968 | 3002.274 | 587.457 | 3002.274 | 9.999+ | 5.111 |
| 57 | 7 | S3 | 0 | 0 | 2941.838 | 441.935 | 2941.838 | 9.999+ | 6.657 |



Company : Vector Structural Engineering
 Designer : STB
 Job Number : U2716.091.181
 Model Name : Ground Mount

Apr 12, 2021
 3:08 PM
 Checked By: JSP

Slab Sliding Safety Factors (Continued)

| | LC | Slab | Angle[deg] | Va-xx[lb] | Vr-xx[lb] | Va-zz[lb] | Vr-zz[lb] | SR-xx | SR-zz |
|-----|----|------|------------|-----------|-----------|-----------|-----------|--------|--------|
| 58 | 7 | S4 | 0 | 3.894 | 2903.5 | 343.617 | 2903.5 | 9.999+ | 8.45 |
| 59 | 7 | S5 | 0 | 0 | 2841.872 | 208.736 | 2841.872 | 9.999+ | 9.999+ |
| 60 | 7 | S6 | 0 | .972 | 2852.526 | 226.617 | 2852.526 | 9.999+ | 9.999+ |
| 61 | 7 | S7 | 0 | 0 | 2848.167 | 221.676 | 2848.167 | 9.999+ | 9.999+ |
| 62 | 7 | S8 | 0 | 1.312 | 2859.143 | 244.14 | 2859.143 | 9.999+ | 9.999+ |
| 63 | 7 | S9 | 0 | 20.593 | 2799.137 | 147.606 | 2799.137 | 9.999+ | 9.999+ |
| 64 | 8 | S1 | 0 | 16.027 | 2546.981 | 407.651 | 2546.981 | 9.999+ | 6.248 |
| 65 | 8 | S2 | 0 | 6.558 | 2528.647 | 558.559 | 2528.647 | 9.999+ | 4.527 |
| 66 | 8 | S3 | 0 | .768 | 2600.557 | 362.238 | 2600.557 | 9.999+ | 7.179 |
| 67 | 8 | S4 | 0 | 3.076 | 2622.642 | 304.787 | 2622.642 | 9.999+ | 8.605 |
| 68 | 8 | S5 | 0 | 0 | 2663.11 | 210.669 | 2663.11 | 9.999+ | 9.999+ |
| 69 | 8 | S6 | 0 | .942 | 2657.506 | 227.034 | 2657.506 | 9.999+ | 9.999+ |
| 70 | 8 | S7 | 0 | .605 | 2658.474 | 221.586 | 2658.474 | 9.999+ | 9.999+ |
| 71 | 8 | S8 | 0 | 1.312 | 2661.093 | 244.156 | 2661.093 | 9.999+ | 9.999+ |
| 72 | 8 | S9 | 0 | 4.116 | 2660.816 | 147.606 | 2660.816 | 9.999+ | 9.999+ |
| 73 | 9 | S1 | 0 | 2.357 | 2650.383 | 667.008 | 2650.383 | 9.999+ | 3.974 |
| 74 | 9 | S2 | 0 | 1.31 | 2645.134 | 1096.636 | 2645.134 | 9.999+ | 2.412 |
| 75 | 9 | S3 | 0 | .936 | 2643.636 | 994.794 | 2643.636 | 9.999+ | 2.657 |
| 76 | 9 | S4 | 0 | .91 | 2643.51 | 1023.899 | 2643.51 | 9.999+ | 2.582 |
| 77 | 9 | S5 | 0 | 0 | 2643.984 | 975.474 | 2643.984 | 9.999+ | 2.71 |
| 78 | 9 | S6 | 0 | .972 | 2643.535 | 1020.554 | 2643.535 | 9.999+ | 2.59 |
| 79 | 9 | S7 | 0 | .552 | 2643.605 | 998.563 | 2643.605 | 9.999+ | 2.647 |
| 80 | 9 | S8 | 0 | 1.317 | 2645.202 | 1095.315 | 2645.202 | 9.999+ | 2.415 |
| 81 | 9 | S9 | 0 | 2.307 | 2650.288 | 666.77 | 2650.288 | 9.999+ | 3.975 |
| 82 | 10 | S1 | 0 | 4.095 | 2694.298 | 563.313 | 2694.298 | 9.999+ | 4.783 |
| 83 | 10 | S2 | 0 | 5.706 | 2720.703 | 918.973 | 2720.703 | 9.999+ | 2.961 |
| 84 | 10 | S3 | 0 | 1.8 | 2711.133 | 838.805 | 2711.133 | 9.999+ | 3.232 |
| 85 | 10 | S4 | 0 | .691 | 2712.359 | 867.398 | 2712.359 | 9.999+ | 3.127 |
| 86 | 10 | S5 | 0 | 0 | 2711.075 | 812.56 | 2711.075 | 9.999+ | 3.336 |
| 87 | 10 | S6 | 0 | .264 | 2712.258 | 863.597 | 2712.258 | 9.999+ | 3.141 |
| 88 | 10 | S7 | 0 | 1.202 | 2711.185 | 843.211 | 2711.185 | 9.999+ | 3.215 |
| 89 | 10 | S8 | 0 | 5.8 | 2720.875 | 917.119 | 2720.875 | 9.999+ | 2.967 |
| 90 | 10 | S9 | 0 | 4.054 | 2694.114 | 563.292 | 2694.114 | 9.999+ | 4.783 |
| 91 | 11 | S1 | 0 | 87.756 | 3312.452 | 790.745 | 3312.452 | 9.999+ | 4.189 |
| 92 | 11 | S2 | 0 | 14.956 | 3635.965 | 1299.818 | 3635.965 | 9.999+ | 2.797 |
| 93 | 11 | S3 | 0 | .535 | 3575.442 | 1179.29 | 3575.442 | 9.999+ | 3.032 |
| 94 | 11 | S4 | 0 | 3.728 | 3592.444 | 1213.937 | 3592.444 | 9.999+ | 2.959 |
| 95 | 11 | S5 | 0 | 0 | 3572.665 | 1156.034 | 3572.665 | 9.999+ | 3.09 |
| 96 | 11 | S6 | 0 | 3.407 | 3591.148 | 1209.937 | 3591.148 | 9.999+ | 2.968 |
| 97 | 11 | S7 | 0 | .681 | 3576.308 | 1183.803 | 3576.308 | 9.999+ | 3.021 |
| 98 | 11 | S8 | 0 | 15.441 | 3636.792 | 1298.225 | 3636.792 | 9.999+ | 2.801 |
| 99 | 11 | S9 | 0 | 87.529 | 3311.514 | 790.469 | 3311.514 | 9.999+ | 4.189 |
| 100 | 12 | S1 | 0 | 81.233 | 3261.432 | 684.618 | 3261.432 | 9.999+ | 4.764 |
| 101 | 12 | S2 | 0 | 17 | 3568.343 | 1131.733 | 3568.343 | 9.999+ | 3.153 |
| 102 | 12 | S3 | 0 | 1.347 | 3508.681 | 1022.2 | 3508.681 | 9.999+ | 3.432 |
| 103 | 12 | S4 | 0 | 3.31 | 3524.555 | 1048.639 | 3524.555 | 9.999+ | 3.361 |
| 104 | 12 | S5 | 0 | 0 | 3505.97 | 1010.87 | 3505.97 | 9.999+ | 3.468 |
| 105 | 12 | S6 | 0 | 3.44 | 3523.327 | 1046.041 | 3523.327 | 9.999+ | 3.368 |
| 106 | 12 | S7 | 0 | .507 | 3509.499 | 1025.023 | 3509.499 | 9.999+ | 3.424 |
| 107 | 12 | S8 | 0 | 17.498 | 3569.159 | 1131.008 | 3569.159 | 9.999+ | 3.156 |
| 108 | 12 | S9 | 0 | 80.964 | 3260.529 | 684.219 | 3260.529 | 9.999+ | 4.765 |
| 109 | 13 | S1 | 0 | 56.762 | 3089.755 | 303.023 | 3089.755 | 9.999+ | 9.999+ |
| 110 | 13 | S2 | 0 | 12.63 | 3280.328 | 440.592 | 3280.328 | 9.999+ | 7.445 |
| 111 | 13 | S3 | 0 | .767 | 3211.428 | 331.451 | 3211.428 | 9.999+ | 9.689 |
| 112 | 13 | S4 | 0 | 1.914 | 3189.106 | 257.712 | 3189.106 | 9.999+ | 9.999+ |
| 113 | 13 | S5 | 0 | 0 | 3135.445 | 156.552 | 3135.445 | 9.999+ | 9.999+ |
| 114 | 13 | S6 | 0 | 1.767 | 3150.388 | 169.963 | 3150.388 | 9.999+ | 9.999+ |



Company : Vector Structural Engineering
 Designer : STB
 Job Number : U2716.091.181
 Model Name : Ground Mount

Apr 12, 2021
 3:08 PM
 Checked By: JSP

Slab Sliding Safety Factors (Continued)

| | LC | Slab | Angle[deg] | Va-xx[lb] | Vr-xx[lb] | Va-zz[lb] | Vr-zz[lb] | SR-xx | SR-zz |
|-----|----|------|------------|-----------|-----------|-----------|-----------|--------|--------|
| 115 | 13 | S7 | 0 | 0 | 3141.496 | 166.257 | 3141.496 | 9.999+ | 9.999+ |
| 116 | 13 | S8 | 0 | 7.836 | 3173.323 | 183.105 | 3173.323 | 9.999+ | 9.999+ |
| 117 | 13 | S9 | 0 | 47.989 | 3004.603 | 110.704 | 3004.603 | 9.999+ | 9.999+ |
| 118 | 14 | S1 | 0 | 20.589 | 2815.859 | 305.738 | 2815.859 | 9.999+ | 9.21 |
| 119 | 14 | S2 | 0 | 1.735 | 2925.108 | 418.919 | 2925.108 | 9.999+ | 6.983 |
| 120 | 14 | S3 | 0 | 1.343 | 2955.467 | 271.678 | 2955.467 | 9.999+ | 9.999+ |
| 121 | 14 | S4 | 0 | 3.313 | 2978.462 | 228.59 | 2978.462 | 9.999+ | 9.999+ |
| 122 | 14 | S5 | 0 | 0 | 3001.374 | 158.002 | 3001.374 | 9.999+ | 9.999+ |
| 123 | 14 | S6 | 0 | .331 | 3004.122 | 170.276 | 3004.122 | 9.999+ | 9.999+ |
| 124 | 14 | S7 | 0 | .454 | 2999.226 | 166.19 | 2999.226 | 9.999+ | 9.999+ |
| 125 | 14 | S8 | 0 | 7.836 | 3024.785 | 183.117 | 3024.785 | 9.999+ | 9.999+ |
| 126 | 14 | S9 | 0 | 29.457 | 2900.862 | 110.704 | 2900.862 | 9.999+ | 9.999+ |
| 127 | 15 | S1 | 0 | 47.459 | 2053.329 | 889.345 | 2053.329 | 9.999+ | 2.309 |
| 128 | 15 | S2 | 0 | 7.253 | 1879.353 | 1462.182 | 1879.353 | 9.999+ | 1.285 |
| 129 | 15 | S3 | 0 | .225 | 1909.454 | 1326.391 | 1909.454 | 9.999+ | 1.44 |
| 130 | 15 | S4 | 0 | 2.556 | 1900.539 | 1365.198 | 1900.539 | 9.999+ | 1.392 |
| 131 | 15 | S5 | 0 | 0 | 1911.272 | 1300.632 | 1911.272 | 9.999+ | 1.469 |
| 132 | 15 | S6 | 0 | 2.681 | 1901.236 | 1360.739 | 1901.236 | 9.999+ | 1.397 |
| 133 | 15 | S7 | 0 | .736 | 1908.976 | 1331.418 | 1908.976 | 9.999+ | 1.434 |
| 134 | 15 | S8 | 0 | 7.511 | 1878.977 | 1460.42 | 1878.977 | 9.999+ | 1.287 |
| 135 | 15 | S9 | 0 | 47.302 | 2053.713 | 889.027 | 2053.713 | 9.999+ | 2.31 |
| 136 | 16 | S1 | 0 | 38.855 | 2111.881 | 751.084 | 2111.881 | 9.999+ | 2.812 |
| 137 | 16 | S2 | 0 | 1.391 | 1980.113 | 1225.298 | 1980.113 | 9.999+ | 1.616 |
| 138 | 16 | S3 | 0 | 1.377 | 1999.449 | 1118.406 | 1999.449 | 9.999+ | 1.788 |
| 139 | 16 | S4 | 0 | 2.263 | 1992.337 | 1156.53 | 1992.337 | 9.999+ | 1.723 |
| 140 | 16 | S5 | 0 | 0 | 2000.727 | 1083.413 | 2000.727 | 9.999+ | 1.847 |
| 141 | 16 | S6 | 0 | 1.737 | 1992.867 | 1151.463 | 1992.867 | 9.999+ | 1.731 |
| 142 | 16 | S7 | 0 | 1.603 | 1999.082 | 1124.281 | 1999.082 | 9.999+ | 1.778 |
| 143 | 16 | S8 | 0 | 1.533 | 1979.875 | 1222.825 | 1979.875 | 9.999+ | 1.619 |
| 144 | 16 | S9 | 0 | 38.82 | 2112.146 | 751.056 | 2112.146 | 9.999+ | 2.812 |
| 145 | 17 | S1 | 0 | 72.692 | 2936.087 | 1054.327 | 2936.087 | 9.999+ | 2.785 |
| 146 | 17 | S2 | 0 | 10.942 | 3200.462 | 1733.091 | 3200.462 | 9.999+ | 1.847 |
| 147 | 17 | S3 | 0 | .309 | 3151.861 | 1572.387 | 3151.861 | 9.999+ | 2.005 |
| 148 | 17 | S4 | 0 | 3.628 | 3165.785 | 1618.583 | 3165.785 | 9.999+ | 1.956 |
| 149 | 17 | S5 | 0 | 0 | 3149.514 | 1541.379 | 3149.514 | 9.999+ | 2.043 |
| 150 | 17 | S6 | 0 | 3.159 | 3164.719 | 1613.25 | 3164.719 | 9.999+ | 1.962 |
| 151 | 17 | S7 | 0 | .908 | 3152.58 | 1578.403 | 3152.58 | 9.999+ | 1.997 |
| 152 | 17 | S8 | 0 | 11.321 | 3201.098 | 1730.967 | 3201.098 | 9.999+ | 1.849 |
| 153 | 17 | S9 | 0 | 72.481 | 2935.346 | 1053.958 | 2935.346 | 9.999+ | 2.785 |
| 154 | 18 | S1 | 0 | 63.996 | 2868.06 | 912.824 | 2868.06 | 9.999+ | 3.142 |
| 155 | 18 | S2 | 0 | 13.668 | 3110.3 | 1508.977 | 3110.3 | 9.999+ | 2.061 |
| 156 | 18 | S3 | 0 | .773 | 3062.847 | 1362.934 | 3062.847 | 9.999+ | 2.247 |
| 157 | 18 | S4 | 0 | 3.071 | 3075.266 | 1398.185 | 3075.266 | 9.999+ | 2.199 |
| 158 | 18 | S5 | 0 | 0 | 3060.587 | 1347.827 | 3060.587 | 9.999+ | 2.271 |
| 159 | 18 | S6 | 0 | 3.203 | 3074.291 | 1394.721 | 3074.291 | 9.999+ | 2.204 |
| 160 | 18 | S7 | 0 | .676 | 3063.501 | 1366.697 | 3063.501 | 9.999+ | 2.242 |
| 161 | 18 | S8 | 0 | 14.063 | 3110.92 | 1508.011 | 3110.92 | 9.999+ | 2.063 |
| 162 | 18 | S9 | 0 | 63.727 | 2867.366 | 912.292 | 2867.366 | 9.999+ | 3.143 |
| 163 | 19 | S1 | 0 | 31.367 | 2639.158 | 404.031 | 2639.158 | 9.999+ | 6.532 |
| 164 | 19 | S2 | 0 | 7.84 | 2726.279 | 587.457 | 2726.279 | 9.999+ | 4.641 |
| 165 | 19 | S3 | 0 | 0 | 2666.51 | 441.935 | 2666.51 | 9.999+ | 6.034 |
| 166 | 19 | S4 | 0 | 3.894 | 2628.001 | 343.617 | 2628.001 | 9.999+ | 7.648 |
| 167 | 19 | S5 | 0 | 0 | 2566.554 | 208.736 | 2566.554 | 9.999+ | 9.999+ |
| 168 | 19 | S6 | 0 | .972 | 2577.039 | 226.617 | 2577.039 | 9.999+ | 9.999+ |
| 169 | 19 | S7 | 0 | 0 | 2572.831 | 221.676 | 2572.831 | 9.999+ | 9.999+ |
| 170 | 19 | S8 | 0 | 1.181 | 2583.139 | 244.14 | 2583.139 | 9.999+ | 9.999+ |
| 171 | 19 | S9 | 0 | 19.759 | 2526.132 | 147.606 | 2526.132 | 9.999+ | 9.999+ |



Slab Sliding Safety Factors (Continued)

| | LC | Slab | Angle[deg] | Va-xx[lb] | Vr-xx[lb] | Va-zz[lb] | Vr-zz[lb] | SR-xx | SR-zz |
|-----|----|------|------------|-----------|-----------|-----------|-----------|--------|--------|
| 172 | 20 | S1 | 0 | 16.863 | 2273.962 | 407.651 | 2273.962 | 9.999+ | 5.578 |
| 173 | 20 | S2 | 0 | 6.686 | 2252.653 | 558.559 | 2252.653 | 9.999+ | 4.033 |
| 174 | 20 | S3 | 0 | .768 | 2325.229 | 362.238 | 2325.229 | 9.999+ | 6.419 |
| 175 | 20 | S4 | 0 | 3.076 | 2347.143 | 304.787 | 2347.143 | 9.999+ | 7.701 |
| 176 | 20 | S5 | 0 | 0 | 2387.792 | 210.669 | 2387.792 | 9.999+ | 9.999+ |
| 177 | 20 | S6 | 0 | .942 | 2382.019 | 227.034 | 2382.019 | 9.999+ | 9.999+ |
| 178 | 20 | S7 | 0 | .605 | 2383.138 | 221.586 | 2383.138 | 9.999+ | 9.999+ |
| 179 | 20 | S8 | 0 | 1.181 | 2385.089 | 244.156 | 2385.089 | 9.999+ | 9.769 |
| 180 | 20 | S9 | 0 | 4.95 | 2387.811 | 147.606 | 2387.811 | 9.999+ | 9.999+ |

Envelope Slab Soil Pressures

| | Label | UC | LC | Soil Pressure[psf] | Allowable Bearing[psf] | Point |
|---|-------|------|----|--------------------|------------------------|-------|
| 1 | S1 | .43 | 5 | 644.378 | 1500 | N254 |
| 2 | S2 | .531 | 5 | 795.962 | 1500 | N261 |
| 3 | S3 | .512 | 5 | 767.411 | 1500 | N268 |
| 4 | S4 | .519 | 5 | 778.439 | 1500 | N275 |
| 5 | S5 | .505 | 5 | 758.173 | 1500 | N282 |
| 6 | S6 | .518 | 5 | 777.024 | 1500 | N289 |
| 7 | S7 | .513 | 5 | 768.932 | 1500 | N296 |
| 8 | S8 | .53 | 5 | 795.517 | 1500 | N303 |
| 9 | S9 | .43 | 5 | 644.27 | 1500 | N310 |



| | | | |
|-----------|--|-------|-----------|
| Company: | | Date: | 5/14/2018 |
| Engineer: | | Page: | 1/6 |
| Project: | | | |
| Address: | | | |
| Phone: | | | |
| E-mail: | | | |

1. Project information

Customer company:
Customer contact name:
Customer e-mail:
Comment:

Project description:
Location:
Fastening description:

2. Input Data & Anchor Parameters

General

Design method: ACI 318-14
Units: Imperial units

Anchor Information:

Anchor type: Bonded anchor
Material: F1554 Grade 36
Diameter (inch): 0.375
Effective Embedment depth, h_{ef} (inch): 6.000
Code report: ICC-ES ESR-4057
Anchor category: -
Anchor ductility: Yes
 h_{min} (inch): 7.25
 c_{ac} (inch): 10.99
 c_{min} (inch): 1.75
 s_{min} (inch): 3.00

Base Material

Concrete: Normal-weight
Concrete thickness, h (inch): 30.00
State: Cracked
Compressive strength, f'_c (psi): 2500
 $\Psi_{c,v}$: 1.0
Reinforcement condition: B tension, B shear
Supplemental reinforcement: Not applicable
Reinforcement provided at corners: No
Ignore concrete breakout in tension: No
Ignore concrete breakout in shear: No
Hole condition: Dry concrete
Inspection: Periodic
Temperature range, Short/Long: 150/110°F
Ignore 6do requirement: Not applicable
Build-up grout pad: No

Base Plate

Length x Width x Thickness (inch): 4.75 x 4.75 x 0.31

Recommended Anchor

Anchor Name: SET-3G - SET-3G w/ 3/8"Ø F1554 Gr. 36
Code Report: ICC-ES ESR-4057





| | | | |
|-----------|--|-------|-----------|
| Company: | | Date: | 5/14/2018 |
| Engineer: | | Page: | 2/6 |
| Project: | | | |
| Address: | | | |
| Phone: | | | |
| E-mail: | | | |

Load and Geometry

Load factor source: ACI 318 Section 5.3

Load combination: not set

Seismic design: No

Anchors subjected to sustained tension: No

Apply entire shear load at front row: No

Anchors only resisting wind and/or seismic loads: No

Strength level loads:

N_{ua} [lb]: 4470

V_{uax} [lb]: 175

V_{uay} [lb]: -3010

M_{ux} [ft-lb]: 0

M_{uy} [ft-lb]: 0

M_{uz} [ft-lb]: 0

<Figure 1>

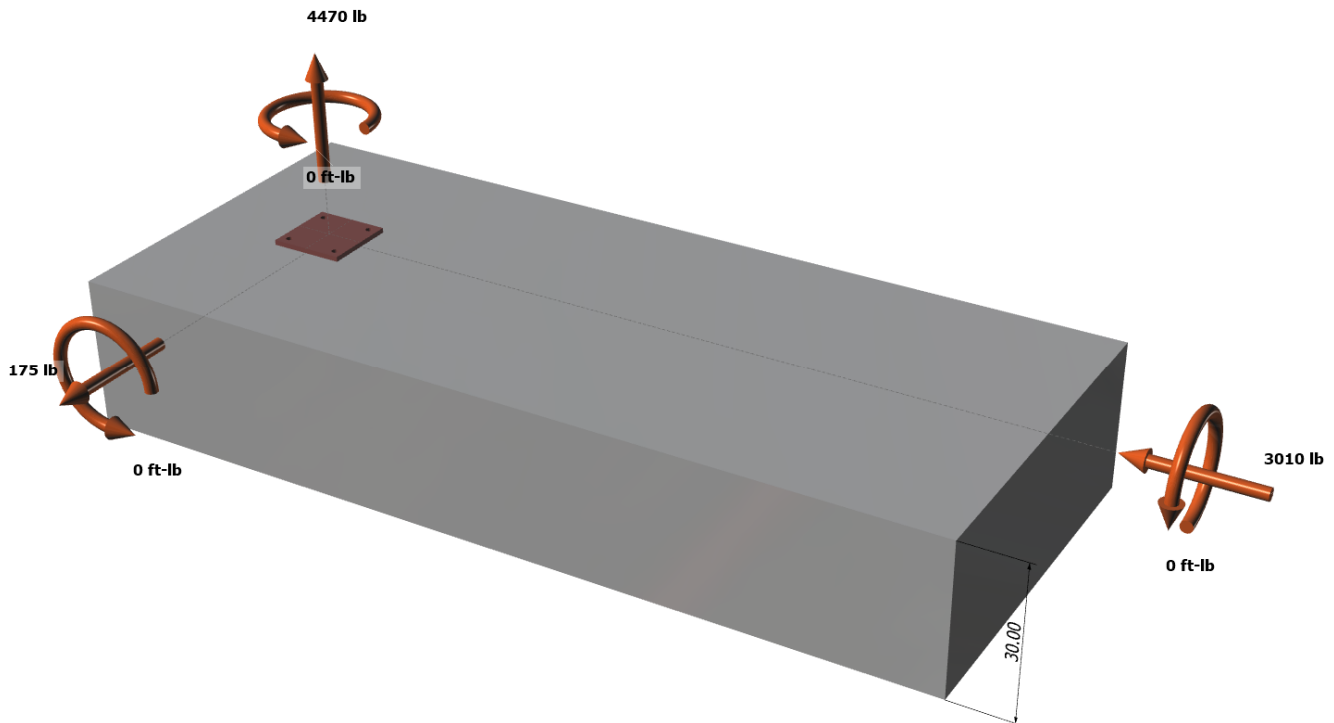

Input data and results must be checked for agreement with the existing circumstances, the standards and guidelines must be checked for plausibility.



| | | | |
|-----------|--|-------|-----------|
| Company: | | Date: | 5/14/2018 |
| Engineer: | | Page: | 3/6 |
| Project: | | | |
| Address: | | | |
| Phone: | | | |
| E-mail: | | | |

<Figure 2>





| | | | |
|-----------|--|-------|-----------|
| Company: | | Date: | 5/14/2018 |
| Engineer: | | Page: | 4/6 |
| Project: | | | |
| Address: | | | |
| Phone: | | | |
| E-mail: | | | |

3. Resulting Anchor Forces

| Anchor | Tension load, N _{ua} (lb) | Shear load x, V _{uax} (lb) | Shear load y, V _{uay} (lb) | Shear load combined, $\sqrt{(V_{uax})^2 + (V_{uay})^2}$ (lb) |
|--------|---------------------------------------|--|--|---|
| 1 | 1117.5 | 43.8 | -752.5 | 753.8 |
| 2 | 1117.5 | 43.8 | -752.5 | 753.8 |
| 3 | 1117.5 | 43.8 | -752.5 | 753.8 |
| 4 | 1117.5 | 43.8 | -752.5 | 753.8 |
| Sum | 4470.0 | 175.0 | -3010.0 | 3015.1 |

Maximum concrete compression strain (%): 0.00
 Maximum concrete compression stress (psi): 0
 Resultant tension force (lb): 4470
 Resultant compression force (lb): 0
 Eccentricity of resultant tension forces in x-axis, e'_{Nx} (inch): 0.00
 Eccentricity of resultant tension forces in y-axis, e'_{Ny} (inch): 0.00
 Eccentricity of resultant shear forces in x-axis, e'_{Vx} (inch): 0.00
 Eccentricity of resultant shear forces in y-axis, e'_{Vy} (inch): 0.00

<Figure 3>

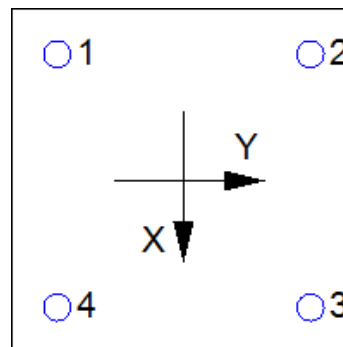

4. Steel Strength of Anchor in Tension (Sec. 17.4.1)

| N _{sa} (lb) | φ | φN _{sa} (lb) |
|----------------------|------|-----------------------|
| 4525 | 0.75 | 3394 |

5. Concrete Breakout Strength of Anchor in Tension (Sec. 17.4.2)

$$N_b = K_c \lambda_a \sqrt{f_c} h_{ef}^{1.5} \text{ (Eq. 17.4.2.2a)}$$

| K _c | λ _a | f _c (psi) | h _{ef} (in) | N _b (lb) |
|----------------|----------------|----------------------|----------------------|---------------------|
| 17.0 | 1.00 | 2500 | 6.000 | 12492 |

$$\phi N_{cbg} = \phi (A_{Nc} / A_{Nco}) \psi_{ec,N} \psi_{ed,N} \psi_{c,N} \psi_{cp,N} N_b \text{ (Sec. 17.3.1 \& Eq. 17.4.2.1b)}$$

| A _{Nc} (in ²) | A _{Nco} (in ²) | c _{a,min} (in) | ψ _{ec,N} | ψ _{ed,N} | ψ _{c,N} | ψ _{cp,N} | N _b (lb) | φ | φN _{cbg} (lb) |
|------------------------------------|-------------------------------------|-------------------------|-------------------|-------------------|------------------|-------------------|---------------------|------|------------------------|
| 424.63 | 324.00 | 7.25 | 1.000 | 0.942 | 1.00 | 1.000 | 12492 | 0.65 | 10021 |

6. Adhesive Strength of Anchor in Tension (Sec. 17.4.5)

$$\tau_{k,cr} = \tau_{k,cr,short-term} K_{sat} (f_c / 2,500)^n$$

| τ _{k,cr} (psi) | f _{short-term} | K _{sat} | f _c (psi) | n | τ _{k,cr} (psi) |
|-------------------------|-------------------------|------------------|----------------------|------|-------------------------|
| 1346 | 1.00 | 1.00 | 2500 | 0.24 | 1346 |

$$N_{ba} = \lambda_a \tau_{cr} \pi d_a h_{ef} \text{ (Eq. 17.4.5.2)}$$

| λ _a | τ _{cr} (psi) | d _a (in) | h _{ef} (in) | N _{ba} (lb) |
|----------------|-----------------------|---------------------|----------------------|----------------------|
| 1.00 | 1346 | 0.38 | 6.000 | 9514 |

$$\phi N_{ag} = \phi (A_{Na} / A_{Na0}) \psi_{ec,Na} \psi_{ed,Na} \psi_{cp,Na} N_{ba} \text{ (Sec. 17.3.1 \& Eq. 17.4.5.1b)}$$

| A _{Na} (in ²) | A _{Na0} (in ²) | c _{Na} (in) | c _{a,min} (in) | ψ _{ec,Na} | ψ _{ed,Na} | ψ _{cp,Na} | N _{ba} (lb) | φ | φN _{ag} (lb) |
|------------------------------------|-------------------------------------|----------------------|-------------------------|--------------------|--------------------|--------------------|----------------------|------|-----------------------|
| 198.45 | 112.09 | 5.29 | 7.25 | 1.000 | 1.000 | 1.000 | 9514 | 0.55 | 9265 |

Input data and results must be checked for agreement with the existing circumstances, the standards and guidelines must be checked for plausibility.



| | | | |
|-----------|--|-------|-----------|
| Company: | | Date: | 5/14/2018 |
| Engineer: | | Page: | 5/6 |
| Project: | | | |
| Address: | | | |
| Phone: | | | |
| E-mail: | | | |

8. Steel Strength of Anchor in Shear (Sec. 17.5.1)

| V_{sa} (lb) | ϕ_{grout} | ϕ | $\phi_{grout}\phi V_{sa}$ (lb) |
|---------------|----------------|--------|--------------------------------|
| 2715 | 1.0 | 0.65 | 1765 |

9. Concrete Breakout Strength of Anchor in Shear (Sec. 17.5.2)

Shear perpendicular to edge in x-direction:

$V_{bx} = \min|7(l_e / d_a)^{0.2} \sqrt{d_a} \lambda_a \sqrt{f_c} c_{a1}^{1.5}; 9 \lambda_a \sqrt{f_c} c_{a1}^{1.5}|$ (Eq. 17.5.2.2a & Eq. 17.5.2.2b)

| l_e (in) | d_a (in) | λ_a | f_c (psi) | c_{a1} (in) | V_{bx} (lb) |
|------------|------------|-------------|-------------|---------------|---------------|
| 3.00 | 0.375 | 1.00 | 2500 | 13.75 | 16564 |

$\phi V_{cbgx} = \phi (A_{Vc} / A_{Vco}) \Psi_{ec,V} \Psi_{ed,V} \Psi_{c,V} \Psi_{h,V} V_{bx}$ (Sec. 17.3.1 & Eq. 17.5.2.1b)

| A_{Vc} (in ²) | A_{Vco} (in ²) | $\Psi_{ec,V}$ | $\Psi_{ed,V}$ | $\Psi_{c,V}$ | $\Psi_{h,V}$ | V_{bx} (lb) | ϕ | ϕV_{cbgx} (lb) |
|-----------------------------|------------------------------|---------------|---------------|--------------|--------------|---------------|--------|----------------------|
| 647.11 | 850.78 | 1.000 | 0.805 | 1.000 | 1.000 | 16564 | 0.70 | 7103 |

Shear perpendicular to edge in y-direction:

$V_{by} = \min|7(l_e / d_a)^{0.2} \sqrt{d_a} \lambda_a \sqrt{f_c} c_{a1}^{1.5}; 9 \lambda_a \sqrt{f_c} c_{a1}^{1.5}|$ (Eq. 17.5.2.2a & Eq. 17.5.2.2b)

| l_e (in) | d_a (in) | λ_a | f_c (psi) | c_{a1} (in) | V_{by} (lb) |
|------------|------------|-------------|-------------|---------------|---------------|
| 3.00 | 0.375 | 1.00 | 2500 | 10.75 | 11450 |

$\phi V_{cbgy} = \phi (A_{Vc} / A_{Vco}) \Psi_{ec,V} \Psi_{ed,V} \Psi_{c,V} \Psi_{h,V} V_{by}$ (Sec. 17.3.1 & Eq. 17.5.2.1b)

| A_{Vc} (in ²) | A_{Vco} (in ²) | $\Psi_{ec,V}$ | $\Psi_{ed,V}$ | $\Psi_{c,V}$ | $\Psi_{h,V}$ | V_{by} (lb) | ϕ | ϕV_{cbgy} (lb) |
|-----------------------------|------------------------------|---------------|---------------|--------------|--------------|---------------|--------|----------------------|
| 387.00 | 520.03 | 1.000 | 0.891 | 1.000 | 1.000 | 11450 | 0.70 | 5313 |

Shear parallel to edge in x-direction:

$V_{by} = \min|7(l_e / d_a)^{0.2} \sqrt{d_a} \lambda_a \sqrt{f_c} c_{a1}^{1.5}; 9 \lambda_a \sqrt{f_c} c_{a1}^{1.5}|$ (Eq. 17.5.2.2a & Eq. 17.5.2.2b)

| l_e (in) | d_a (in) | λ_a | f_c (psi) | c_{a1} (in) | V_{by} (lb) |
|------------|------------|-------------|-------------|---------------|---------------|
| 3.00 | 0.375 | 1.00 | 2500 | 7.25 | 6342 |

$\phi V_{cbgx} = \phi (2)(A_{Vc} / A_{Vco}) \Psi_{ec,V} \Psi_{ed,V} \Psi_{c,V} \Psi_{h,V} V_{by}$ (Sec. 17.3.1, 17.5.2.1(c) & Eq. 17.5.2.1b)

| A_{Vc} (in ²) | A_{Vco} (in ²) | $\Psi_{ec,V}$ | $\Psi_{ed,V}$ | $\Psi_{c,V}$ | $\Psi_{h,V}$ | V_{by} (lb) | ϕ | ϕV_{cbgx} (lb) |
|-----------------------------|------------------------------|---------------|---------------|--------------|--------------|---------------|--------|----------------------|
| 261.00 | 236.53 | 1.000 | 1.000 | 1.000 | 1.000 | 6342 | 0.70 | 9797 |

Shear parallel to edge in y-direction:

$V_{bx} = \min|7(l_e / d_a)^{0.2} \sqrt{d_a} \lambda_a \sqrt{f_c} c_{a1}^{1.5}; 9 \lambda_a \sqrt{f_c} c_{a1}^{1.5}|$ (Eq. 17.5.2.2a & Eq. 17.5.2.2b)

| l_e (in) | d_a (in) | λ_a | f_c (psi) | c_{a1} (in) | V_{bx} (lb) |
|------------|------------|-------------|-------------|---------------|---------------|
| 3.00 | 0.375 | 1.00 | 2500 | 10.25 | 10661 |

$\phi V_{cbgy} = \phi (2)(A_{Vc} / A_{Vco}) \Psi_{ec,V} \Psi_{ed,V} \Psi_{c,V} \Psi_{h,V} V_{bx}$ (Sec. 17.3.1, 17.5.2.1(c) & Eq. 17.5.2.1b)

| A_{Vc} (in ²) | A_{Vco} (in ²) | $\Psi_{ec,V}$ | $\Psi_{ed,V}$ | $\Psi_{c,V}$ | $\Psi_{h,V}$ | V_{bx} (lb) | ϕ | ϕV_{cbgy} (lb) |
|-----------------------------|------------------------------|---------------|---------------|--------------|--------------|---------------|--------|----------------------|
| 401.67 | 472.78 | 1.000 | 1.000 | 1.000 | 1.000 | 10661 | 0.70 | 12680 |

10. Concrete Pryout Strength of Anchor in Shear (Sec. 17.5.3)

$\phi V_{cp} = \phi \min|k_{cp} N_{ba}; k_{cp} N_{cb}| = \phi \min|k_{cp} (A_{Na} / A_{Na0}) \Psi_{ec,Na} \Psi_{ed,Na} \Psi_{cp,Na} N_{ba}; k_{cp} (A_{Nc} / A_{Nco}) \Psi_{ec,N} \Psi_{ed,N} \Psi_{cp,N} N_{cb}|$ (Sec. 17.3.1 & Eq. 17.5.3.1b)

| k_{cp} | A_{Na} (in ²) | A_{Na0} (in ²) | $\Psi_{ed,Na}$ | $\Psi_{ec,Na}$ | $\Psi_{cp,Na}$ | N_{ba} (lb) | N_a (lb) |
|----------|-----------------------------|------------------------------|----------------|----------------|----------------|---------------|------------|
| 2.0 | 198.45 | 112.09 | 1.000 | 1.000 | 1.000 | 9514 | 16845 |

| A_{Nc} (in ²) | A_{Nco} (in ²) | $\Psi_{ec,N}$ | $\Psi_{ed,N}$ | $\Psi_{c,N}$ | $\Psi_{cp,N}$ | N_b (lb) | N_{cb} (lb) | ϕ |
|-----------------------------|------------------------------|---------------|---------------|--------------|---------------|------------|---------------|--------|
| 424.63 | 324.00 | 1.000 | 0.942 | 1.000 | 1.000 | 12492 | 15417 | 0.70 |

Input data and results must be checked for agreement with the existing circumstances, the standards and guidelines must be checked for plausibility.



| | | | |
|-----------|--|-------|-----------|
| Company: | | Date: | 5/14/2018 |
| Engineer: | | Page: | 6/6 |
| Project: | | | |
| Address: | | | |
| Phone: | | | |
| E-mail: | | | |

ϕV_{cpq} (lb)
21584

11. Results

Interaction of Tensile and Shear Forces (Sec. R17.6)

| Tension | Factored Load, N_{ua} (lb) | Design Strength, ϕN_n (lb) | Ratio | Status | |
|------------------------------------|------------------------------|----------------------------------|----------------|-----------------------|--------|
| Steel | 1118 | 3394 | 0.33 | Pass | |
| Concrete breakout | 4470 | 10021 | 0.45 | Pass | |
| Adhesive | 4470 | 9265 | 0.48 | Pass (Governs) | |
| Shear | Factored Load, V_{ua} (lb) | Design Strength, ϕV_n (lb) | Ratio | Status | |
| Steel | 754 | 1765 | 0.43 | Pass | |
| T Concrete breakout x+ | 175 | 7103 | 0.02 | Pass | |
| T Concrete breakout y- | 3010 | 5313 | 0.57 | Pass | |
| Concrete breakout y- | 88 | 9797 | 0.01 | Pass | |
| Concrete breakout x- | 1505 | 12680 | 0.12 | Pass | |
| Concrete breakout, combined | - | - | 0.57 | Pass (Governs) | |
| Pryout | 3015 | 21584 | 0.14 | Pass | |
| Interaction check | $(N_{ua}/\phi N_{ua})^{5/3}$ | $(V_{ua}/\phi V_{ua})^{5/3}$ | Combined Ratio | Permissible | Status |
| Sec. R17.6 | 0.30 | 0.39 | 68.5% | 1.0 | Pass |

SET-3G w/ 3/8"Ø F1554 Gr. 36 with hef = 6.000 inch meets the selected design criteria.

12. Warnings

- Designer must exercise own judgement to determine if this design is suitable.
- Refer to manufacturer's product literature for hole cleaning and installation instructions.



JOB NO.: U2716-070-181

DESIGNED: STB

PROJECT: Ground Mount Package for Ontario Canada

Framing Analysis

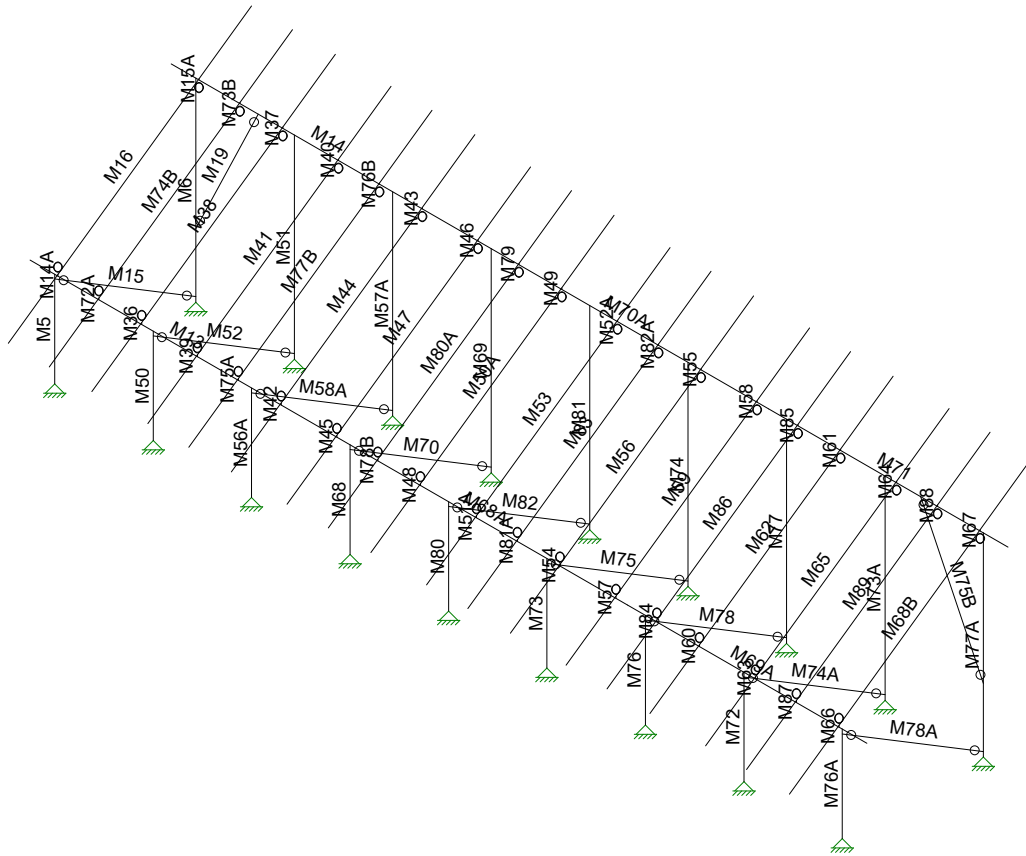

Vector Structural Engineeri...
STB
U2716.091.191

Ground Mount

SK - 3
Apr 12, 2021 at 3:06 PM
Sunmodo Sunturf A3 v7 85x45.r3d

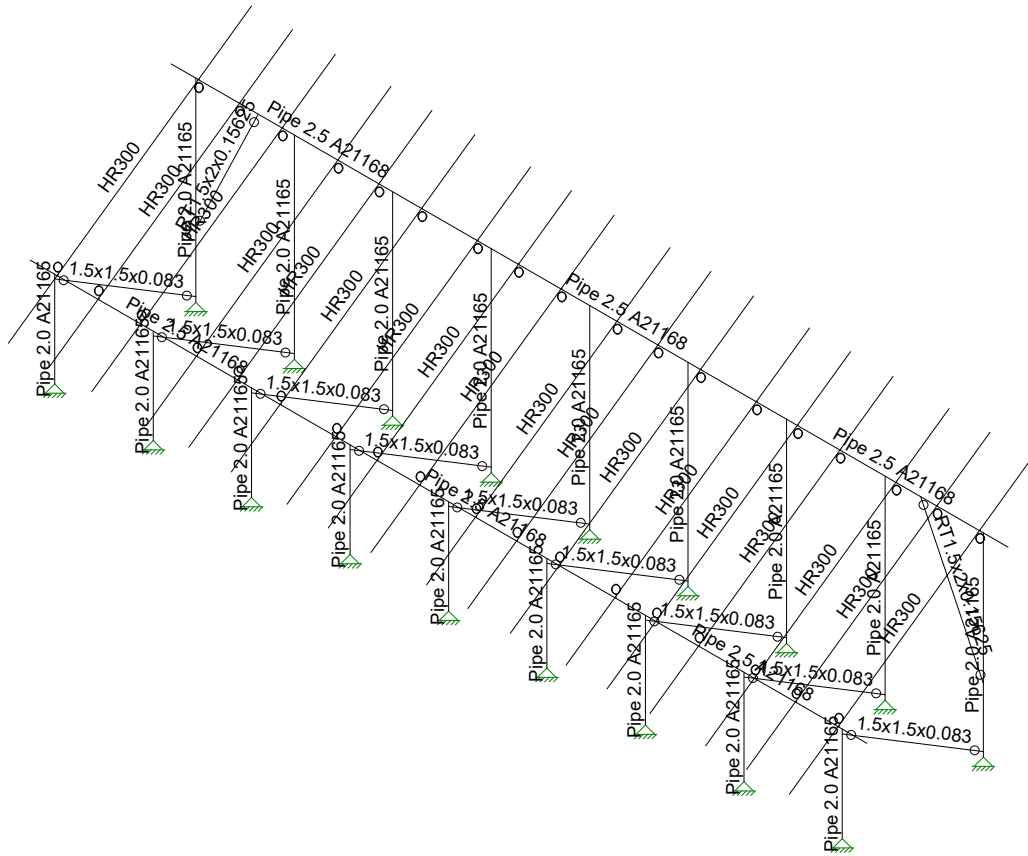

Vector Structural Engineeri...

STB

U2716.091.191

Ground Mount

SK - 4

Apr 12, 2021 at 3:06 PM

Sunmodo Sunturf A3 v7 85x45.r3d

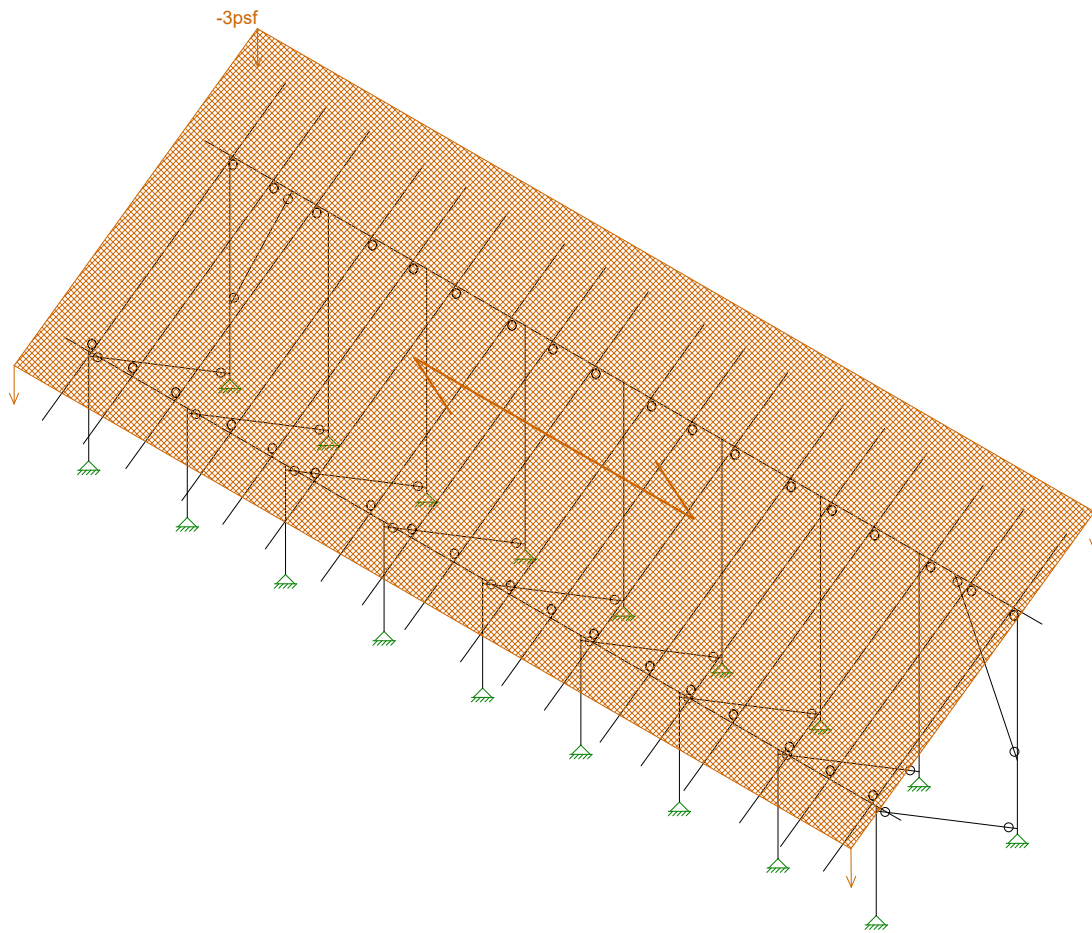

Loads: BLC 2, Solar Panel Weight

| | | |
|-------------------------------|--------------|---------------------------------|
| Vector Structural Engineeri.. | Ground Mount | SK - 5 |
| STB | | Apr 12, 2021 at 3:06 PM |
| U2716.091.191 | | Sunmodo Sunturf A3 v7 85x45.r3d |

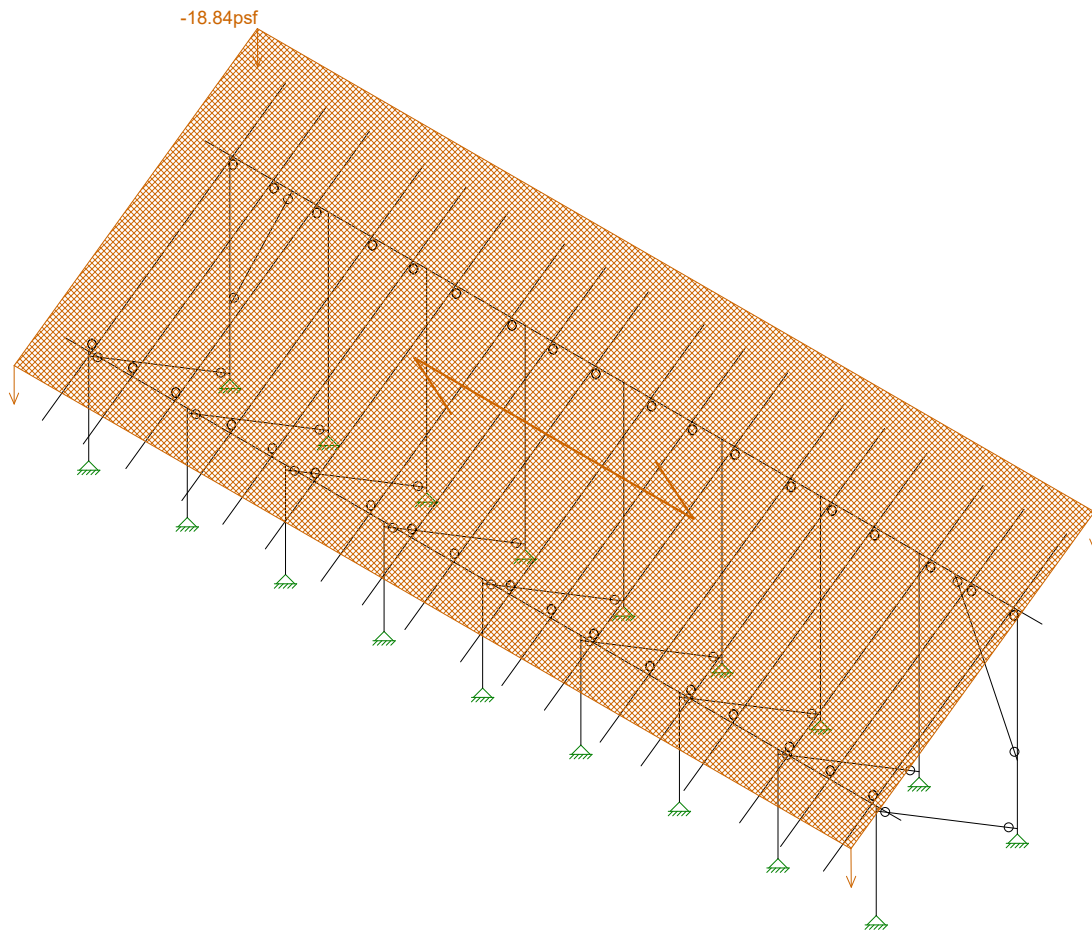

Loads: BLC 3, Roof Live/Snow

| | | |
|-------------------------------|--------------|---------------------------------|
| Vector Structural Engineeri.. | Ground Mount | SK - 6 |
| STB | | Apr 12, 2021 at 3:06 PM |
| U2716.091.191 | | Sunmodo Sunturf A3 v7 85x45.r3d |

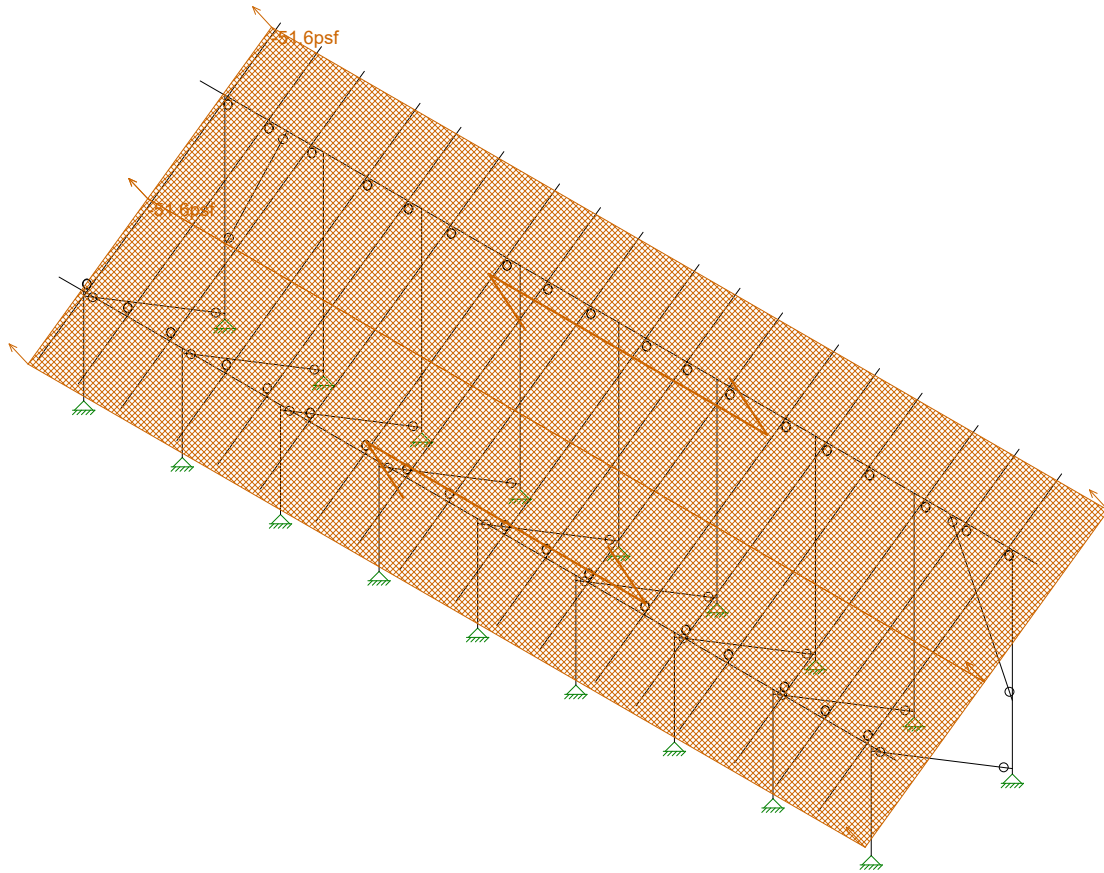

Loads: BLC 4, Wind A 0 deg

| | | |
|-------------------------------|--------------|---------------------------------|
| Vector Structural Engineeri.. | Ground Mount | SK - 7 |
| STB | | Apr 12, 2021 at 3:06 PM |
| U2716.091.191 | | Sunmodo Sunturf A3 v7 85x45.r3d |

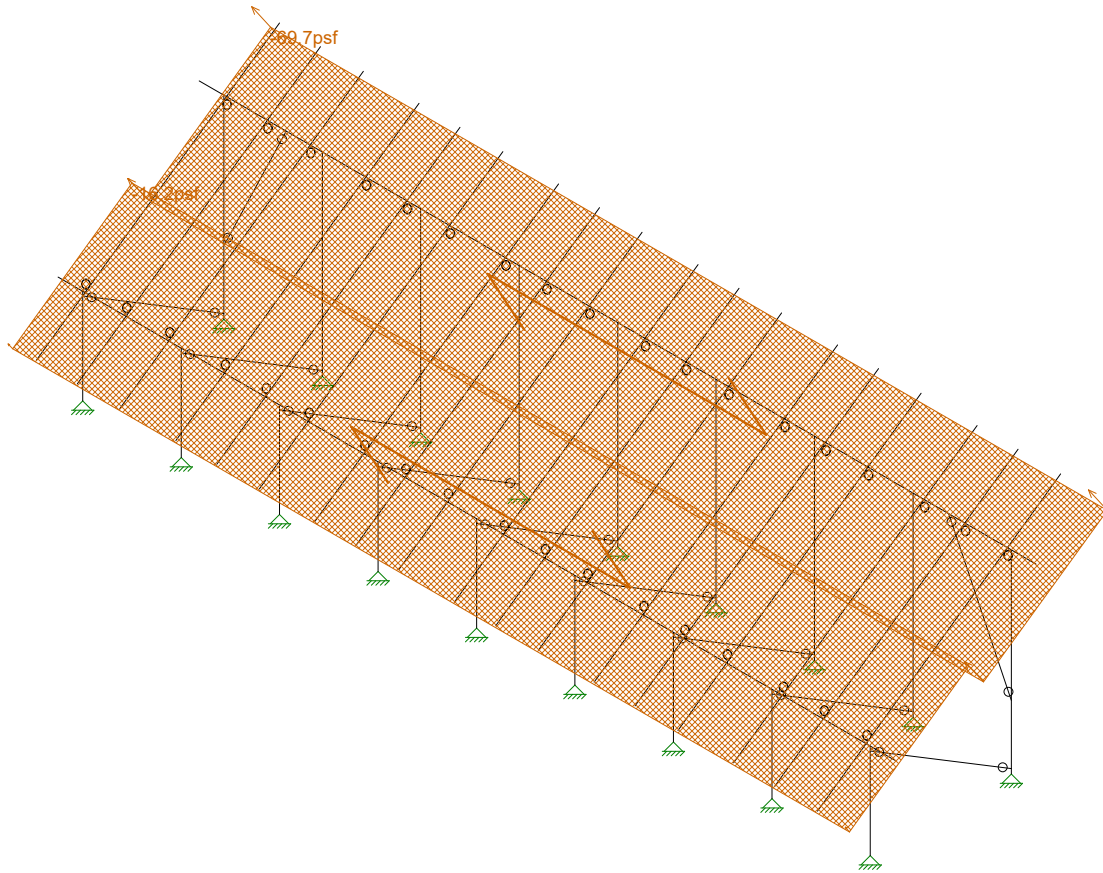

Loads: BLC 5, Wind B 0 deg

| | | |
|--------------------------------|--------------|---------------------------------|
| Vector Structural Engineeri... | Ground Mount | SK - 8 |
| STB | | Apr 12, 2021 at 3:07 PM |
| U2716.091.191 | | Sunmodo Sunturf A3 v7 85x45.r3d |

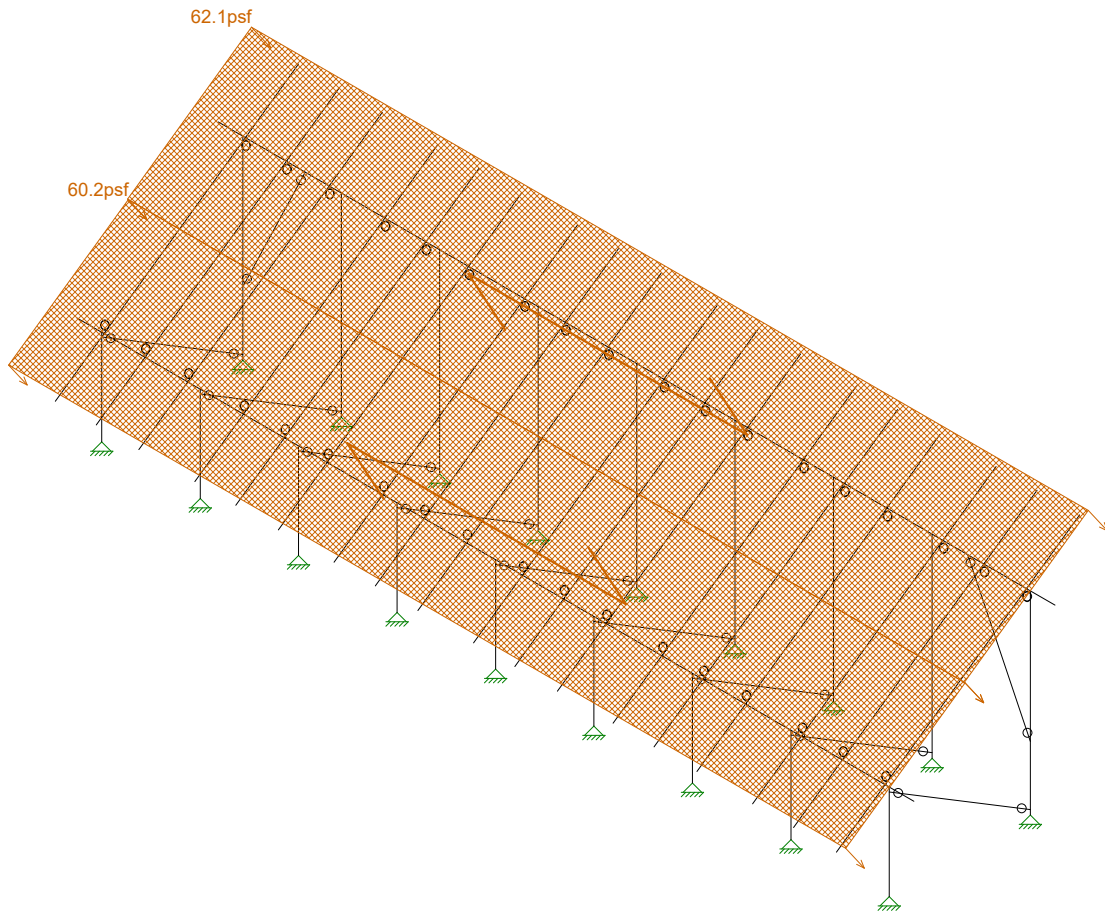

Loads: BLC 6, Wind A 180 deg

Vector Structural Engineeri...
STB
U2716.091.191

Ground Mount

SK - 9

Apr 12, 2021 at 3:07 PM

Sunmodo Sunturf A3 v7 85x45.r3d

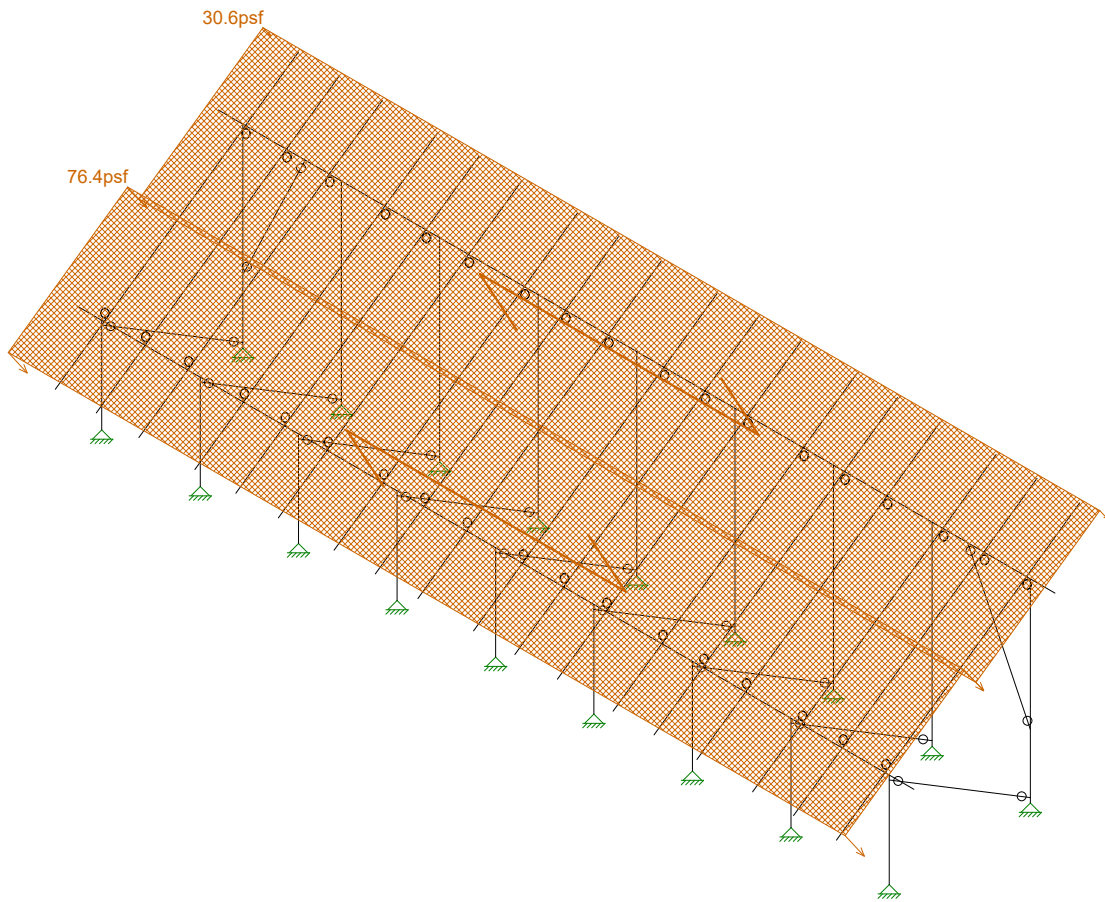

Loads: BLC 7, Wind B 180 deg

Vector Structural Engineeri...
STB
U2716.091.191

Ground Mount

SK - 10

Apr 12, 2021 at 3:07 PM

Sunmodo Sunturf A3 v7 85x45.r3d

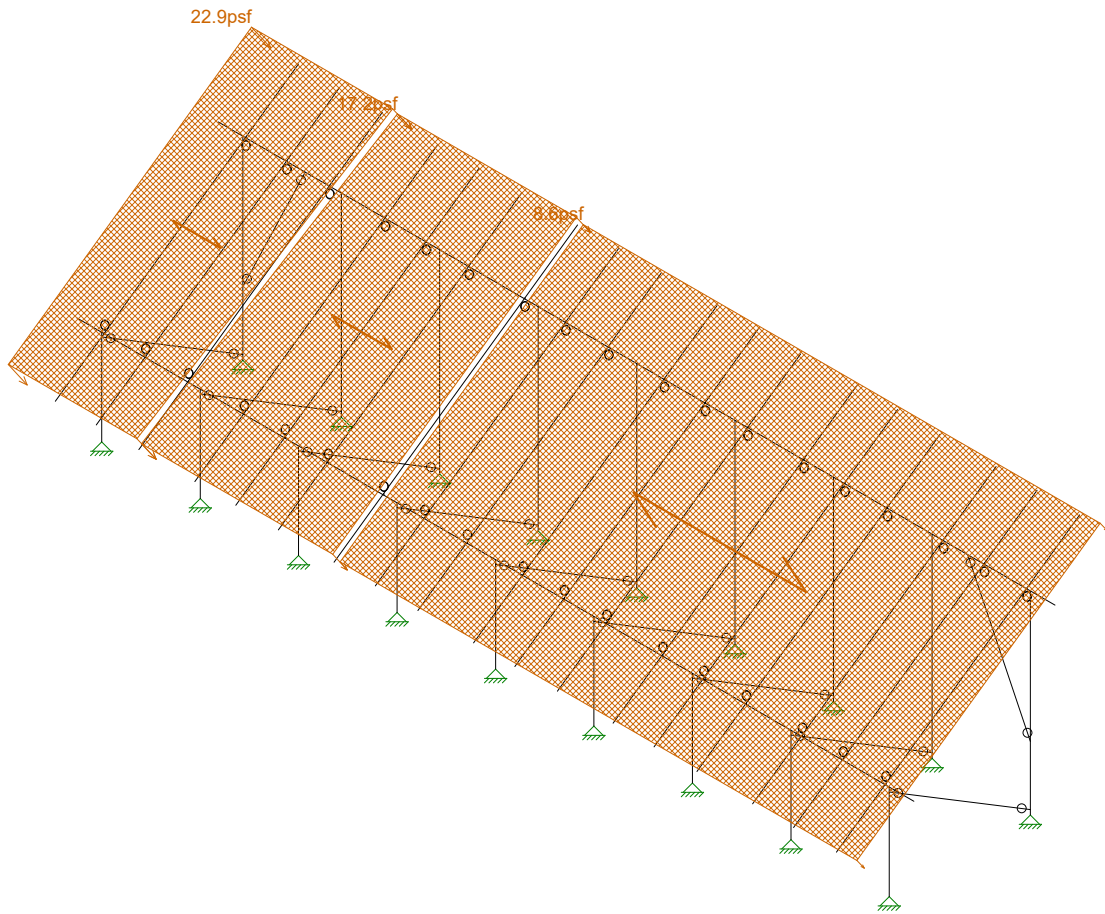

Loads: BLC 8, Wind A 90

| | | |
|--------------------------------|--------------|---------------------------------|
| Vector Structural Engineeri... | Ground Mount | SK - 11 |
| STB | | Apr 12, 2021 at 3:07 PM |
| U2716.091.191 | | Sunmodo Sunturf A3 v7 85x45.r3d |

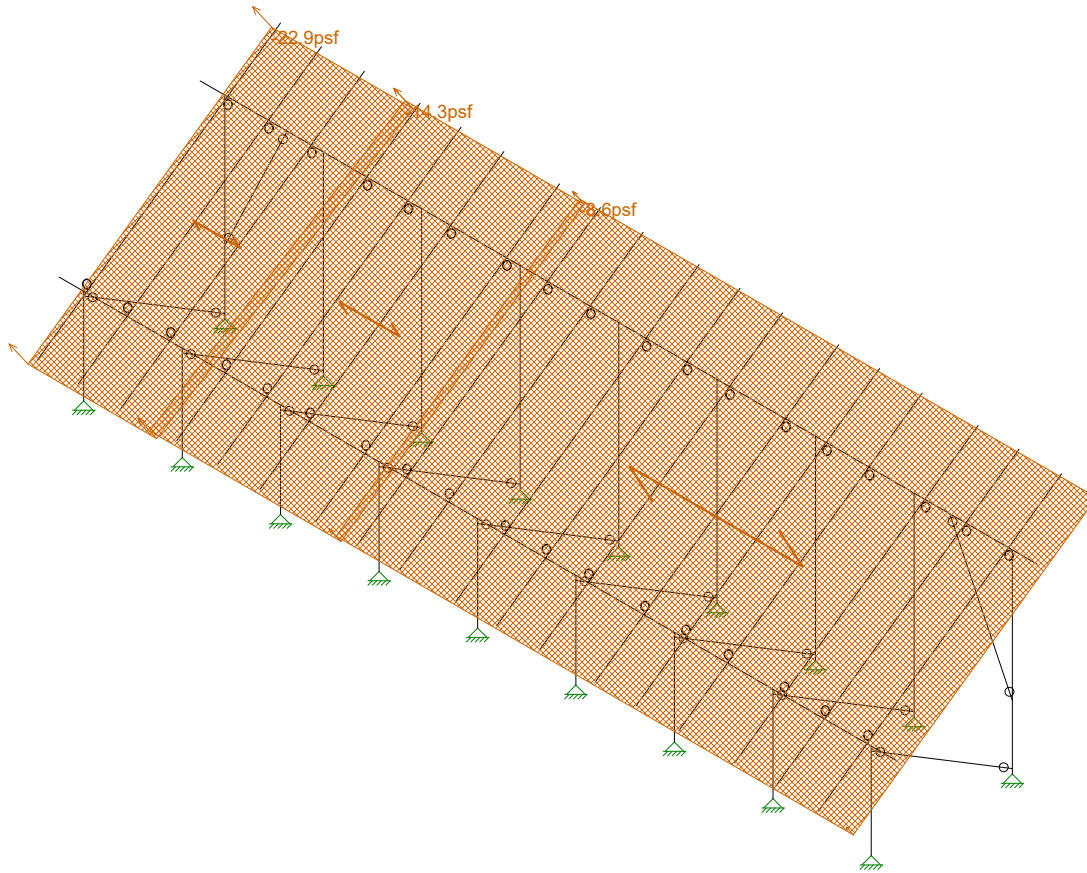

Loads: BLC 9, Wind B 90

| | | |
|-------------------------------|--------------|---------------------------------|
| Vector Structural Engineeri.. | Ground Mount | SK - 12 |
| STB | | Apr 12, 2021 at 3:07 PM |
| U2716.091.191 | | Sunmodo Sunturf A3 v7 85x45.r3d |



| Code Check (Env) | |
|------------------|---------|
| Black | No Calc |
| Red | > 1.0 |
| Magenta | .90-1.0 |
| Green | .75-.90 |
| Cyan | .50-.75 |
| Blue | 0-.50 |

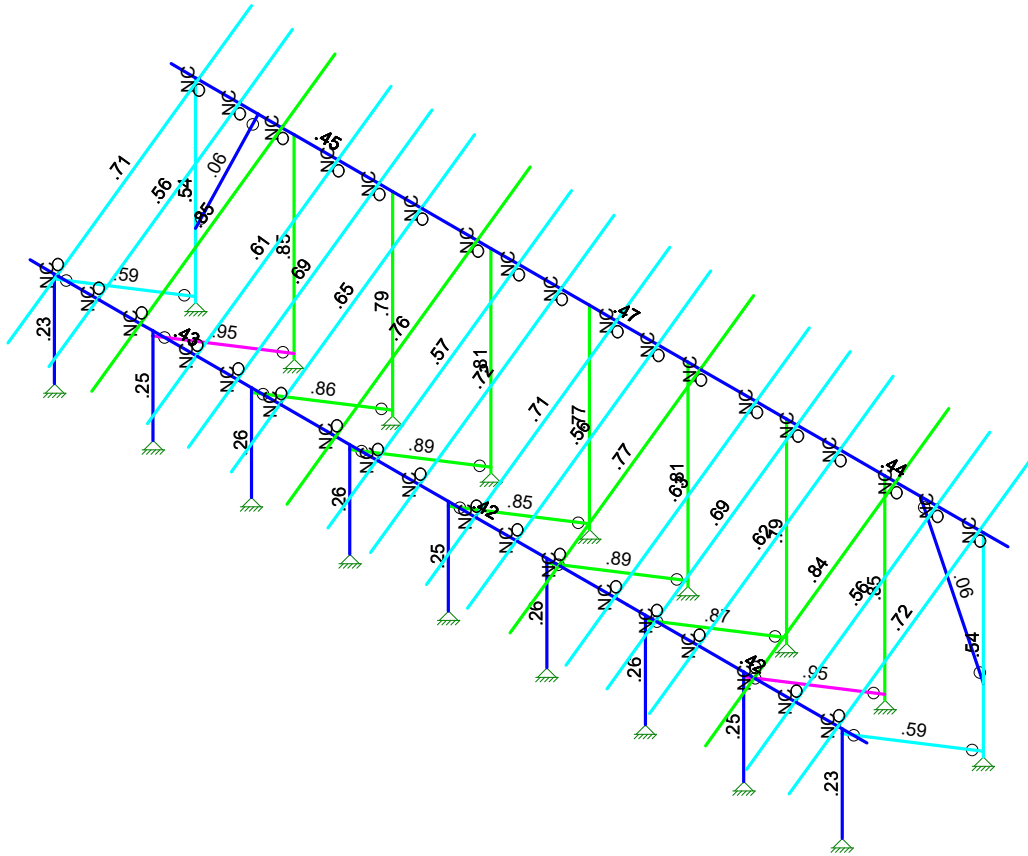

Member Code Checks Displayed (Enveloped)
Envelope Only Solution

| | | |
|--------------------------------|--------------|---------------------------------|
| Vector Structural Engineeri... | Ground Mount | SK - 1 |
| STB | | Apr 12, 2021 at 3:05 PM |
| U2716.091.191 | | Sunmodo Sunturf A3 v7 85x45.r3d |

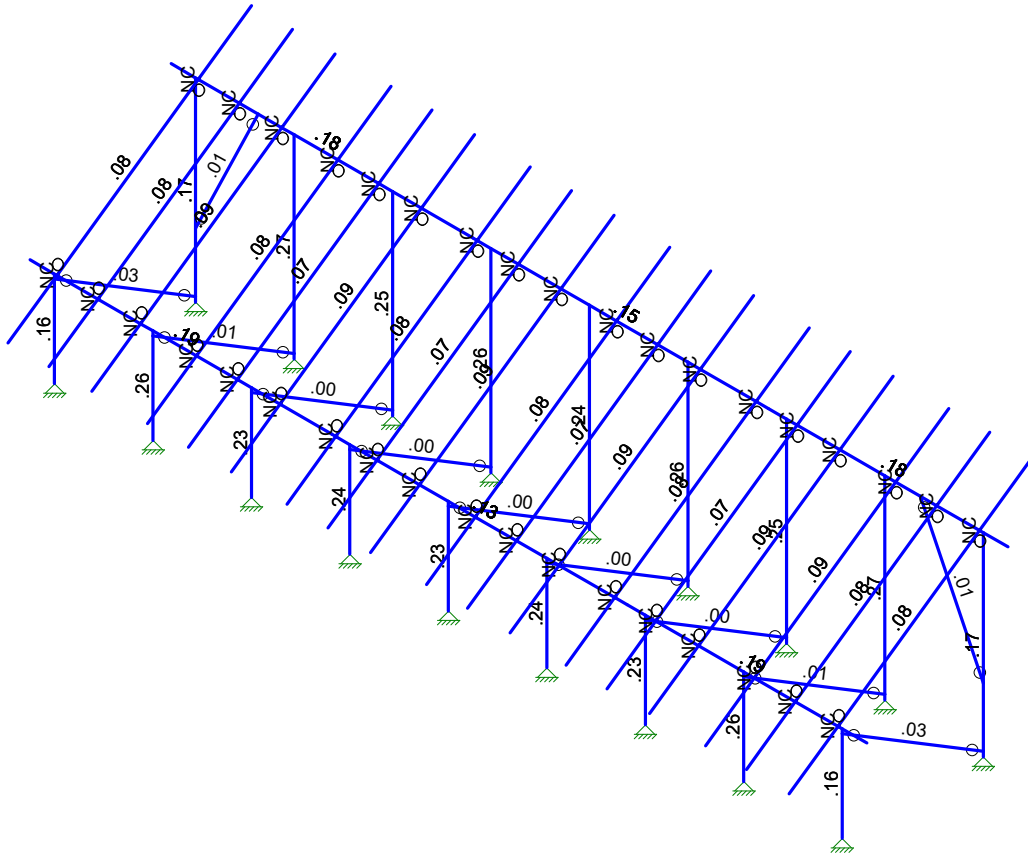
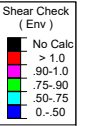

Member Shear Checks Displayed (Enveloped)
Envelope Only Solution

Vector Structural Engineeri...
STB
U2716.091.191

Ground Mount

SK - 2

Apr 12, 2021 at 3:06 PM

Sunmodo Sunturf A3 v7 85x45.r3d

(Global) Model Settings

| | |
|--|--------------------|
| Display Sections for Member Calcs | 5 |
| Max Internal Sections for Member Calcs | 97 |
| Include Shear Deformation? | Yes |
| Increase Nailing Capacity for Wind? | Yes |
| Include Warping? | Yes |
| Trans Load Btwn Intersecting Wood Wall? | Yes |
| Area Load Mesh (in^2) | 144 |
| Merge Tolerance (in) | .12 |
| P-Delta Analysis Tolerance | 0.50% |
| Include P-Delta for Walls? | Yes |
| Automatically Iterate Stiffness for Walls? | Yes |
| Max Iterations for Wall Stiffness | 3 |
| Gravity Acceleration (in/sec^2) | 386.4 |
| Wall Mesh Size (in) | 24 |
| Eigensolution Convergence Tol. (1.E-) | 4 |
| Vertical Axis | Y |
| Global Member Orientation Plane | XZ |
| Static Solver | Sparse Accelerated |
| Dynamic Solver | Accelerated Solver |

| | |
|------------------------|----------------------------|
| Hot Rolled Steel Code | AISC 15th(360-16): ASD |
| Adjust Stiffness? | Yes(Iterative) |
| RISACONNECTION CODE | AISC 15th(360-16): ASD |
| Cold Formed Steel Code | AISI S100-16: ASD |
| Wood Code | AWC NDS-18: ASD |
| Wood Temperature | < 100F |
| Concrete Code | ACI 318-14 |
| Masonry Code | None |
| Aluminum Code | AA ADM1-15: ASD - Building |
| Stainless Steel Code | AISC 14th(360-10): ASD |
| Adjust Stiffness? | Yes(Iterative) |

| | |
|-------------------------------|--------------------|
| Number of Shear Regions | 4 |
| Region Spacing Increment (in) | 4 |
| Biaxial Column Method | Exact Integration |
| Parme Beta Factor (PCA) | .65 |
| Concrete Stress Block | Rectangular |
| Use Cracked Sections? | Yes |
| Use Cracked Sections Slab? | No |
| Bad Framing Warnings? | No |
| Unused Force Warnings? | Yes |
| Min 1 Bar Diam. Spacing? | No |
| Concrete Rebar Set | REBAR SET ASTMA615 |
| Min % Steel for Column | 1 |
| Max % Steel for Column | 8 |

(Global) Model Settings, Continued

| | |
|-----------------------------|-------------|
| Seismic Code | ASCE 7-16 |
| Seismic Base Elevation (in) | 15600 |
| Add Base Weight? | Yes |
| Ct X | .02 |
| Ct Z | .02 |
| T X (sec) | Not Entered |
| T Z (sec) | Not Entered |
| R X | 3 |
| R Z | 3 |
| Ct Exp. X | .75 |
| Ct Exp. Z | .75 |
| SD1 | 1 |
| SDS | 1 |
| S1 | 1 |
| TL (sec) | 5 |
| Risk Cat | I or II |
| Drift Cat | Other |
| Om Z | 1 |
| Om X | 1 |
| Cd Z | 4 |
| Cd X | 4 |
| Rho Z | 1 |
| Rho X | 1 |
| | |

Hot Rolled Steel Properties

| | Label | E [ksi] | G [ksi] | Nu | Therm (/1E5 F) | Density[lb/ft^3] | Yield[psi] | Ry | Fu[psi] | Rt |
|---|-----------------|---------|---------|----|----------------|------------------|------------|-----|---------|-----|
| 1 | A992 | 29000 | 11154 | .3 | .65 | 490 | 50000 | 1.1 | 65000 | 1.1 |
| 2 | A36 Gr.36 | 29000 | 11154 | .3 | .65 | 490 | 36000 | 1.5 | 58000 | 1.2 |
| 3 | A572 Gr.50 | 29000 | 11154 | .3 | .65 | 490 | 50000 | 1.1 | 65000 | 1.1 |
| 4 | A500 Gr.B R... | 29000 | 11154 | .3 | .65 | 527 | 42000 | 1.4 | 58000 | 1.3 |
| 5 | A500 Gr.B Re... | 29000 | 11154 | .3 | .65 | 527 | 46000 | 1.4 | 58000 | 1.3 |
| 6 | A53 Gr.B | 29000 | 11154 | .3 | .65 | 490 | 35000 | 1.6 | 60000 | 1.2 |
| 7 | A1085 | 29000 | 11154 | .3 | .65 | 490 | 50000 | 1.4 | 65000 | 1.3 |

Aluminum Properties

| | Label | E [ksi] | G [ksi] | Nu | Therm (...Density[... Table B.4 | kt | Ftu[psi] | Fty[psi] | Fcy[psi] | Fsu[psi] | Ct |
|---|-----------|---------|---------|-----|---------------------------------|----|----------|----------|----------|----------|-----|
| 1 | 3003-H14 | 10100 | 3787.5 | .33 | 1.3 172.8 Table B.4-1 | 1 | 19000 | 16000 | 13000 | 12000 | 141 |
| 2 | 6061-T6 | 10100 | 3787.5 | .33 | 1.3 172.8 Table B.4-2 | 1 | 38000 | 35000 | 35000 | 24000 | 141 |
| 3 | 6063-T5 | 10100 | 3787.5 | .33 | 1.3 172.8 Table B.4-2 | 1 | 22000 | 16000 | 16000 | 13000 | 141 |
| 4 | 6063-T6 | 10100 | 3787.5 | .33 | 1.3 172.8 Table B.4-2 | 1 | 30000 | 25000 | 25000 | 19000 | 141 |
| 5 | 5052-H34 | 10200 | 3787.5 | .33 | 1.3 172.8 Table B.4-1 | 1 | 34000 | 26000 | 24000 | 20000 | 141 |
| 6 | 6061-T6 W | 10100 | 3787.5 | .33 | 1.3 172.8 Table B.4-1 | 1 | 24000 | 15000 | 15000 | 15000 | 141 |
| 7 | 6005-T5 | 10100 | 3787.5 | .33 | 1.3 172.8 Table B.4-1 | 1 | 38000 | 35000 | 35000 | 24000 | 141 |

Hot Rolled Steel Section Sets

| | Label | Shape | Type | Design List | Material | Design R... | A [in2] | Iyy [in4] | Izz [in4] | J [in4] |
|---|----------------|-----------------|--------|-------------|------------|-------------|---------|-----------|-----------|---------|
| 1 | Post | Pipe 2.0 A21165 | Column | Pipe | A572 Gr.50 | Typical | .776 | .499 | .499 | .998 |
| 2 | Cross Beam | Pipe 2.5 A21168 | Beam | Wide Flange | A572 Gr.50 | Typical | .947 | .907 | .907 | 1.814 |
| 3 | Diagonal Brace | 1.5x1.5x0.083 | HBrace | SquareTube | A572 Gr.50 | Typical | .47 | .158 | .158 | .236 |



Company : Vector Structural Engineering
 Designer : STB
 Job Number : U2716.091.191
 Model Name : Ground Mount

Apr 12, 2021
 3:07 PM
 Checked By: _____

Aluminum Section Sets

| | Label | Shape | Type | Design List | Material | Design R... | A [in2] | Iyy [in4] | Izz [in4] | J [in4] |
|---|---------------|-----------------|--------|-------------------|----------|-------------|---------|-----------|-----------|---------|
| 1 | AL Posts | 2.375ODX0.188 | Column | Pipe | 6005-T5 | Typical | 1.29 | .778 | .778 | 1.54 |
| 2 | AL Brace | RT1.5x2x0.15625 | VBrace | Rectangular Tubes | 6005-T5 | Typical | .996 | .327 | .524 | .602 |
| 3 | AL Rails | HR300 | Beam | Rectangular Tubes | 6005-T5 | Typical | .74 | .253 | .727 | .578 |
| 4 | AL Cross Beam | Cross Rail | Beam | Rectangular Tubes | 6005-T5 | Typical | 1.909 | 1.97 | 4.366 | 4.017 |

Member Area Loads (BLC 2 : Solar Panel Weight)

| | Joint A | Joint B | Joint C | Joint D | Direction | Distribution | Magnitude[psf] |
|---|---------|---------|---------|---------|-----------|--------------|----------------|
| 1 | N197 | N200 | N199 | N196 | Y | A-B | -3 |

Member Area Loads (BLC 3 : Roof Live/Snow)

| | Joint A | Joint B | Joint C | Joint D | Direction | Distribution | Magnitude[psf] |
|---|---------|---------|---------|---------|-----------|--------------|----------------|
| 1 | N197 | N200 | N199 | N196 | PY | A-B | -23 |

Member Area Loads (BLC 4 : Wind A 0 deg)

| | Joint A | Joint B | Joint C | Joint D | Direction | Distribution | Magnitude[psf] |
|---|---------|---------|---------|---------|-----------|--------------|----------------|
| 1 | N197 | N200 | N201 | N198 | Perp | A-B | -51.6 |
| 2 | N198 | N201 | N199 | N196 | Perp | A-B | -51.6 |

Member Area Loads (BLC 5 : Wind B 0 deg)

| | Joint A | Joint B | Joint C | Joint D | Direction | Distribution | Magnitude[psf] |
|---|---------|---------|---------|---------|-----------|--------------|----------------|
| 1 | N197 | N200 | N201 | N198 | Perp | A-B | -69.7 |
| 2 | N198 | N201 | N199 | N196 | Perp | A-B | -16.2 |

Member Area Loads (BLC 6 : Wind A 180 deg)

| | Joint A | Joint B | Joint C | Joint D | Direction | Distribution | Magnitude[psf] |
|---|---------|---------|---------|---------|-----------|--------------|----------------|
| 1 | N197 | N200 | N201 | N198 | Perp | A-B | 62.1 |
| 2 | N198 | N201 | N199 | N196 | Perp | A-B | 60.2 |

Member Area Loads (BLC 7 : Wind B 180 deg)

| | Joint A | Joint B | Joint C | Joint D | Direction | Distribution | Magnitude[psf] |
|---|---------|---------|---------|---------|-----------|--------------|----------------|
| 1 | N197 | N200 | N201 | N198 | Perp | A-B | 30.6 |
| 2 | N198 | N201 | N199 | N196 | Perp | A-B | 76.4 |

Member Area Loads (BLC 8 : Wind A 90)

| | Joint A | Joint B | Joint C | Joint D | Direction | Distribution | Magnitude[psf] |
|---|---------|---------|---------|---------|-----------|--------------|----------------|
| 1 | N197 | N203 | N202 | N196 | Perp | A-B | 22.9 |
| 2 | N203 | N209 | N208 | N202 | Perp | A-B | 17.2 |
| 3 | N209 | N200 | N199 | N208 | Perp | A-B | 8.6 |

Member Area Loads (BLC 9 : Wind B 90)

| | Joint A | Joint B | Joint C | Joint D | Direction | Distribution | Magnitude[psf] |
|---|---------|---------|---------|---------|-----------|--------------|----------------|
| 1 | N197 | N203 | N202 | N196 | Perp | A-B | -22.9 |
| 2 | N203 | N209 | N208 | N202 | Perp | A-B | -14.3 |
| 3 | N209 | N200 | N199 | N208 | Perp | A-B | -8.6 |

Basic Load Cases

| | BLC Description | Category | X Gravity | Y Gravity | Z Gravity | Joint | Point | Distributed | Area(M...Surface... |
|---|--------------------|----------|-----------|-----------|-----------|-------|-------|-------------|---------------------|
| 1 | Self Weight | DL | | -1.05 | | | | | |
| 2 | Solar Panel Weight | DL | | | | | | | 1 |



Company : Vector Structural Engineering
 Designer : STB
 Job Number : U2716.091.191
 Model Name : Ground Mount

Apr 12, 2021
 3:07 PM
 Checked By: _____

Basic Load Cases (Continued)

| | BLC Description | Category | X Gravity | Y Gravity | Z Gravity | Joint | Point | Distributed | Area(M... Surface... |
|----|--------------------------|----------|-----------|-----------|-----------|-------|-------|-------------|----------------------|
| 3 | Roof Live/Snow | RLL | | | | | | | 1 |
| 4 | Wind A 0 deg | OL1 | | | | | | | 2 |
| 5 | Wind B 0 deg | OL2 | | | | | | | 2 |
| 6 | Wind A 180 deg | OL3 | | | | | | | 2 |
| 7 | Wind B 180 deg | OL4 | | | | | | | 2 |
| 8 | Wind A 90 | OL5 | | | | | | | 3 |
| 9 | Wind B 90 | OL6 | | | | | | | 3 |
| 10 | BLC 2 Transient Area ... | None | | | | | | 42 | |
| 11 | BLC 3 Transient Area ... | None | | | | | | 42 | |
| 12 | BLC 4 Transient Area ... | None | | | | | | 136 | |
| 13 | BLC 5 Transient Area ... | None | | | | | | 136 | |
| 14 | BLC 6 Transient Area ... | None | | | | | | 136 | |
| 15 | BLC 7 Transient Area ... | None | | | | | | 136 | |
| 16 | BLC 8 Transient Area ... | None | | | | | | 172 | |
| 17 | BLC 9 Transient Area ... | None | | | | | | 172 | |

Load Combinations

| | Description | S... | PD... | SRSS | BLC Fa... | BLC Fa... | BLC Fa... | B... | Fa... | B... | Fa... | B... | Fa... | B... | Fa... | B... | Fa... | B... | Fa... | B... | Fa... |
|----|-------------------------|------|-------|------|-----------|-----------|-----------|------|-------|------|-------|------|-------|------|-------|------|-------|------|-------|------|-------|
| 1 | 1.0 D | Yes | Y | | DL | 1 | | | | | | | | | | | | | | | |
| 2 | 1.0 D + 1.0 S | Yes | Y | | DL | 1 | RLL | 1 | | | | | | | | | | | | | |
| 3 | 1.0 D + 0.6 W1 | Yes | Y | | DL | 1 | RLL | | OL1 | .6 | | | | | | | | | | | |
| 4 | 1.0 D + 0.6 W2 | Yes | Y | | DL | 1 | RLL | | OL2 | .6 | | | | | | | | | | | |
| 5 | 1.0 D + 0.6 W3 | Yes | Y | | DL | 1 | RLL | | OL3 | .6 | | | | | | | | | | | |
| 6 | 1.0 D + 0.6 W4 | Yes | Y | | DL | 1 | RLL | | OL4 | .6 | | | | | | | | | | | |
| 7 | 1.0 D + 0.6 W5 | Yes | Y | | DL | 1 | RLL | | OL5 | .6 | | | | | | | | | | | |
| 8 | 1.0 D + 0.6 W6 | Yes | Y | | DL | 1 | RLL | | OL6 | .6 | | | | | | | | | | | |
| 9 | 1.0 D + 0.45 W1 + 0.... | Yes | Y | | DL | 1 | RLL | .75 | OL1 | .45 | | | | | | | | | | | |
| 10 | 1.0 D + 0.45 W2 + 0.... | Yes | Y | | DL | 1 | RLL | .75 | OL2 | .45 | | | | | | | | | | | |
| 11 | 1.0 D + 0.45 W3 + 0.... | Yes | Y | | DL | 1 | RLL | .75 | OL3 | .45 | | | | | | | | | | | |
| 12 | 1.0 D + 0.45 W4 + 0.... | Yes | Y | | DL | 1 | RLL | .75 | OL4 | .45 | | | | | | | | | | | |
| 13 | 1.0 D + 0.45 W5 + 0.... | Yes | Y | | DL | 1 | RLL | .75 | OL5 | .45 | | | | | | | | | | | |
| 14 | 1.0 D + 0.45 W6 + 0.... | Yes | Y | | DL | 1 | RLL | .75 | OL6 | .45 | | | | | | | | | | | |
| 15 | 0.6 D + 0.6 W1 | Yes | Y | | DL | .6 | RLL | | OL1 | .6 | | | | | | | | | | | |
| 16 | 0.6 D + 0.6 W2 | Yes | Y | | DL | .6 | RLL | | OL2 | .6 | | | | | | | | | | | |
| 17 | 0.6 D + 0.6 W3 | Yes | Y | | DL | .6 | RLL | | OL3 | .6 | | | | | | | | | | | |
| 18 | 0.6 D + 0.6 W4 | Yes | Y | | DL | .6 | RLL | | OL4 | .6 | | | | | | | | | | | |
| 19 | 0.6 D + 0.6 W5 | Yes | Y | | DL | .6 | RLL | | OL5 | .6 | | | | | | | | | | | |
| 20 | 0.6 D + 0.6 W6 | Yes | Y | | DL | .6 | RLL | | OL6 | .6 | | | | | | | | | | | |
| 21 | | | | | | | | | | | | | | | | | | | | | |
| 22 | 1.4D | | | | DL | 1.4 | | | | | | | | | | | | | | | |
| 23 | 1.2D+1.6SL | | | | DL | 1.2 | RLL | 1.6 | | | | | | | | | | | | | |
| 24 | 1.2D+1.6SL+.5Wx | | | | DL | 1.2 | RLL | 1.6 | OL1 | .5 | | | | | | | | | | | |
| 25 | 1.2D+1.6SL-.5Wx | | | | DL | 1.2 | RLL | 1.6 | OL2 | .5 | | | | | | | | | | | |
| 26 | 1.2D+1.6SL+.5Wz | | | | DL | 1.2 | RLL | 1.6 | OL3 | .5 | | | | | | | | | | | |
| 27 | 1.2D+1.6SL-.5Wz | | | | DL | 1.2 | RLL | 1.6 | OL4 | .5 | | | | | | | | | | | |
| 28 | 1.2D+1.6SL+.5W90 | | | | DL | 1.2 | RLL | 1.6 | OL5 | .5 | | | | | | | | | | | |
| 29 | 1.2D+1.6SL-.5W90 | | | | DL | 1.2 | RLL | 1.6 | OL6 | .5 | | | | | | | | | | | |
| 30 | 1.2D+1.0Wx | | | | DL | 1.2 | | | OL1 | 1 | | | | | | | | | | | |
| 31 | 1.2D-1.0Wx | | | | DL | 1.2 | | | OL2 | 1 | | | | | | | | | | | |
| 32 | 1.2D+1.0Wz | | | | DL | 1.2 | | | OL3 | 1 | | | | | | | | | | | |
| 33 | 1.2D-1.0Wz | | | | DL | 1.2 | | | OL4 | 1 | | | | | | | | | | | |
| 34 | 1.2D+1.0W90 | | | | DL | 1.2 | | | OL5 | 1 | | | | | | | | | | | |
| 35 | 1.2D-1.0W90 | | | | DL | 1.2 | | | OL6 | 1 | | | | | | | | | | | |
| 36 | .9D+1.0Wx | | | | DL | .9 | | | OL1 | 1 | | | | | | | | | | | |
| 37 | .9D-1.0Wx | | | | DL | .9 | | | OL2 | 1 | | | | | | | | | | | |



Company : Vector Structural Engineering
 Designer : STB
 Job Number : U2716.091.191
 Model Name : Ground Mount

Apr 12, 2021
 3:07 PM
 Checked By: _____

Load Combinations (Continued)

| | Description | S... | PD... | SRSS | BLC | Fa... | BLC | Fa... | BLC | Fa... | B... | Fa... | B... | Fa... | B... | Fa... | B... | Fa... | B... | Fa... | B... | Fa... | B... |
|----|-------------|------|-------|------|-----|-------|-----|-------|-----|-------|------|-------|------|-------|------|-------|------|-------|------|-------|------|-------|------|
| 38 | .9D+1.0Wz | | | | DL | .9 | | | OL3 | 1 | | | | | | | | | | | | | |
| 39 | .9D-1.0Wz | | | | DL | .9 | | | OL4 | 1 | | | | | | | | | | | | | |
| 40 | .9D+1.0W90 | | | | DL | .9 | | | OL5 | 1 | | | | | | | | | | | | | |
| 41 | .9D-1.0W90 | | | | DL | .9 | | | OL6 | 1 | | | | | | | | | | | | | |

Envelope Joint Reactions

| | Joint | | X [lb] | LC | Y [lb] | LC | Z [lb] | LC | MX [lb-ft] | LC | MY [lb...] | LC | MZ [lb-ft] | LC |
|----|---------|-----|---------|----|------------|----|-----------|----|------------|----|------------|----|------------|----|
| 1 | N2 | max | 44.752 | 12 | 978.358 | 10 | 50.802 | 3 | 0 | 20 | 0 | 20 | 0 | 20 |
| 2 | | min | -18.627 | 15 | -289.288 | 17 | -59.707 | 5 | 0 | 1 | 0 | 1 | 0 | 1 |
| 3 | N1 | max | 41.339 | 11 | 2085.1 | 5 | 1113.7... | 5 | 0 | 20 | 0 | 20 | 0 | 20 |
| 4 | | min | -46.662 | 16 | -1745.949 | 16 | -940.19 | 3 | 0 | 1 | 0 | 1 | 0 | 1 |
| 5 | N132 | max | .217 | 20 | 2943.303 | 5 | 1615.6... | 5 | 0 | 20 | 0 | 20 | 0 | 20 |
| 6 | | min | -.087 | 16 | -2443.902 | 16 | -1364.... | 3 | 0 | 1 | 0 | 1 | 0 | 1 |
| 7 | N133 | max | .353 | 7 | 1401.494 | 10 | 63.464 | 3 | 0 | 20 | 0 | 20 | 0 | 20 |
| 8 | | min | -.227 | 20 | -427.661 | 17 | -74.169 | 5 | 0 | 1 | 0 | 1 | 0 | 1 |
| 9 | N109 | max | 3.582 | 16 | 3224.826 | 5 | 1806.1... | 5 | 0 | 20 | 0 | 20 | 0 | 20 |
| 10 | | min | -4.764 | 11 | -2651.098 | 16 | -1524.... | 3 | 0 | 1 | 0 | 1 | 0 | 1 |
| 11 | N110A | max | 4.506 | 20 | 1563.949 | 10 | 62.459 | 3 | 0 | 20 | 0 | 20 | 0 | 20 |
| 12 | | min | -14.181 | 12 | -520.272 | 17 | -72.386 | 5 | 0 | 1 | 0 | 1 | 0 | 1 |
| 13 | N121 | max | 1.283 | 16 | 2993.082 | 5 | 1646.5... | 5 | 0 | 20 | 0 | 20 | 0 | 20 |
| 14 | | min | -1.278 | 5 | -2502.517 | 16 | -1389.... | 3 | 0 | 1 | 0 | 1 | 0 | 1 |
| 15 | N122 | max | 1.525 | 17 | 1441.701 | 10 | 63.688 | 3 | 0 | 20 | 0 | 20 | 0 | 20 |
| 16 | | min | -2.918 | 10 | -473.032 | 17 | -74.249 | 5 | 0 | 1 | 0 | 1 | 0 | 1 |
| 17 | N133B | max | 1.11 | 8 | 3072.604 | 5 | 1693.2... | 5 | 0 | 20 | 0 | 20 | 0 | 20 |
| 18 | | min | -1.007 | 19 | -2570.667 | 16 | -1429.... | 3 | 0 | 1 | 0 | 1 | 0 | 1 |
| 19 | N134B | max | 3.555 | 12 | 1486.766 | 10 | 64.479 | 3 | 0 | 20 | 0 | 20 | 0 | 20 |
| 20 | | min | -2.607 | 19 | -502.208 | 17 | -74.953 | 5 | 0 | 1 | 0 | 1 | 0 | 1 |
| 21 | N151 | max | .558 | 16 | 3063.665 | 5 | 1687.8... | 5 | 0 | 20 | 0 | 20 | 0 | 20 |
| 22 | | min | -.825 | 11 | -2561.966 | 16 | -1425.... | 3 | 0 | 1 | 0 | 1 | 0 | 1 |
| 23 | N152 | max | 2.501 | 15 | 1480.904 | 10 | 64.4 | 3 | 0 | 20 | 0 | 20 | 0 | 20 |
| 24 | | min | -3.712 | 12 | -496.786 | 17 | -74.889 | 5 | 0 | 1 | 0 | 1 | 0 | 1 |
| 25 | N157A | max | 1.113 | 5 | 3002.279 | 5 | 1652.6... | 5 | 0 | 20 | 0 | 20 | 0 | 20 |
| 26 | | min | -1.116 | 16 | -2511.729 | 16 | -1395.... | 3 | 0 | 1 | 0 | 1 | 0 | 1 |
| 27 | N158A | max | 2.773 | 4 | 1448.11 | 10 | 63.78 | 3 | 0 | 20 | 0 | 20 | 0 | 20 |
| 28 | | min | -2.011 | 17 | -479.823 | 17 | -74.32 | 5 | 0 | 1 | 0 | 1 | 0 | 1 |
| 29 | N157 | max | 46.78 | 16 | 2083.9 | 5 | 1113.3... | 5 | 0 | 20 | 0 | 20 | 0 | 20 |
| 30 | | min | -41.473 | 11 | -1744.782 | 16 | -939.8... | 3 | 0 | 1 | 0 | 1 | 0 | 1 |
| 31 | N158 | max | 18.383 | 15 | 977.538 | 10 | 50.784 | 3 | 0 | 20 | 0 | 20 | 0 | 20 |
| 32 | | min | -44.414 | 12 | -290.399 | 17 | -59.682 | 5 | 0 | 1 | 0 | 1 | 0 | 1 |
| 33 | N149 | max | 4.982 | 11 | 3222.786 | 5 | 1803.9... | 5 | 0 | 20 | 0 | 20 | 0 | 20 |
| 34 | | min | -3.738 | 16 | -2648.553 | 16 | -1522.... | 3 | 0 | 1 | 0 | 1 | 0 | 1 |
| 35 | N150 | max | 14.529 | 12 | 1562.096 | 10 | 62.436 | 3 | 0 | 20 | 0 | 20 | 0 | 20 |
| 36 | | min | -4.606 | 15 | -516.271 | 17 | -72.38 | 5 | 0 | 1 | 0 | 1 | 0 | 1 |
| 37 | Totals: | max | .006 | 7 | 26492.194 | 11 | 13496... | 17 | | | | | | |
| 38 | | min | -.005 | 8 | -14474.559 | 15 | -1138... | 3 | | | | | | |

Envelope AISC 15th(360-16): ASD Steel Code Checks

| Member | Shape | Code Check | Loc[in] | LC | Shear | ... | Loc[in] | Dir | LC | Pnc/om | [..Pnt/om | [lb]Mnyy/om.. | Mnzz/om.. | Cb | Eqn |
|--------|-------|----------------|---------|--------|-------|------|---------|-----|-----------|-----------|-----------|---------------|-----------|-------|-------|
| 1 | M5 | Pipe 2.0 A2... | .235 | 55.424 | 6 | .161 | 55.424 | 5 | 15885.263 | 23232.186 | 1397.505 | 1397.505 | 1... | H1-1b | |
| 2 | M6 | Pipe 2.0 A2... | .542 | 2.466 | 5 | .167 | 0 | 5 | 5356.594 | 23232.186 | 1397.505 | 1397.505 | 1... | H1-1a | |
| 3 | M13 | Pipe 2.5 A2... | .432 | 74.75 | 12 | .187 | 74.75 | 5 | 11641.036 | 28358.413 | 2081.747 | 2081.747 | 1... | H1-1b | |
| 4 | M14 | Pipe 2.5 A2... | .451 | 74.75 | 11 | .182 | 74.75 | 11 | 11641.036 | 28358.413 | 2081.747 | 2081.747 | 1... | H1-1b | |
| 5 | M15 | 1.5x1.5x0.083 | .589 | 52.42 | 5 | .031 | 100.... | y | 11 | 2344.073 | 14085.15 | 624.421 | 624.421 | 1... | H1-1a |
| 6 | M80 | Pipe 2.0 A2... | .254 | 54.822 | 17 | .229 | 55.424 | 5 | 15885.263 | 23232.186 | 1397.505 | 1397.505 | 1... | H1-1b | |

Envelope AISC 15th(360-16): ASD Steel Code Checks (Continued)

| Member | Shape | Code Check | Loc[in] | LC Shear | ... | Loc[in] | Dir | LC Pnc/om | [..Pnt/om | [lb]Mnyy/om | Mnzz/om | ..Cb | Eqn | | |
|--------|-------|----------------|---------|----------|-----|---------|---------|-----------|-----------|-------------|----------|----------|---------|-------|-------|
| 7 | M81 | Pipe 2.0 A2... | .772 | 2.466 | 5 | .245 | 0 | 5 | 5356.594 | 23232.186 | 1397.505 | 1397.505 | 1... | H1-1a | |
| 8 | M82 | 1.5x1.5x0.083 | .848 | 52.42 | 5 | .002 | 100.... | y | 8 | 2344.073 | 14085.15 | 624.421 | 624.421 | 1... | H1-1a |
| 9 | M50 | Pipe 2.0 A2... | .253 | 54.822 | 17 | .258 | 55.424 | 5 | 15885.263 | 23232.186 | 1397.505 | 1397.505 | 1... | H1-1b | |
| 10 | M51 | Pipe 2.0 A2... | .852 | 2.466 | 5 | .275 | 0 | 5 | 5356.594 | 23232.186 | 1397.505 | 1397.505 | 1... | H1-1a | |
| 11 | M52 | 1.5x1.5x0.083 | .947 | 52.42 | 5 | .006 | 0 | y | 13 | 2344.073 | 14085.15 | 624.421 | 624.421 | 1... | H1-1a |
| 12 | M56A | Pipe 2.0 A2... | .256 | 54.822 | 17 | .234 | 55.424 | 5 | 15885.263 | 23232.186 | 1397.505 | 1397.505 | 1... | H1-1b | |
| 13 | M57A | Pipe 2.0 A2... | .786 | 2.466 | 5 | .249 | 0 | 5 | 5356.594 | 23232.186 | 1397.505 | 1397.505 | 1... | H1-1a | |
| 14 | M58A | 1.5x1.5x0.083 | .864 | 52.42 | 5 | .003 | 100.... | y | 10 | 2344.073 | 14085.15 | 624.421 | 624.421 | 1... | H1-1a |
| 15 | M68 | Pipe 2.0 A2... | .260 | 54.822 | 17 | .241 | 55.424 | 5 | 15885.263 | 23232.186 | 1397.505 | 1397.505 | 1... | H1-1b | |
| 16 | M69 | Pipe 2.0 A2... | .807 | 2.466 | 5 | .257 | 0 | 5 | 5356.594 | 23232.186 | 1397.505 | 1397.505 | 1... | H1-1a | |
| 17 | M70 | 1.5x1.5x0.083 | .888 | 52.42 | 5 | .004 | 100.... | y | 5 | 2344.073 | 14085.15 | 624.421 | 624.421 | 1... | H1-1a |
| 18 | M68A | Pipe 2.5 A2... | .425 | 71.25 | 6 | .129 | 131.25 | 5 | 11641.036 | 28358.413 | 2081.747 | 2081.747 | 1... | H1-1b | |
| 19 | M69A | Pipe 2.5 A2... | .421 | 71.479 | 12 | .187 | 71.479 | 5 | 11641.036 | 28358.413 | 2081.747 | 2081.747 | 1... | H1-1b | |
| 20 | M70A | Pipe 2.5 A2... | .473 | 71.25 | 11 | .150 | 131.25 | 11 | 11641.036 | 28358.413 | 2081.747 | 2081.747 | 1... | H1-1b | |
| 21 | M71 | Pipe 2.5 A2... | .438 | 71.479 | 11 | .182 | 71.479 | 11 | 11641.036 | 28358.413 | 2081.747 | 2081.747 | 1... | H1-1b | |
| 22 | M73 | Pipe 2.0 A2... | .259 | 54.822 | 17 | .240 | 55.424 | 5 | 15885.263 | 23232.186 | 1397.505 | 1397.505 | 1... | H1-1b | |
| 23 | M74 | Pipe 2.0 A2... | .805 | 2.466 | 5 | .256 | 0 | 5 | 5356.594 | 23232.186 | 1397.505 | 1397.505 | 1... | H1-1a | |
| 24 | M75 | 1.5x1.5x0.083 | .886 | 52.42 | 5 | .005 | 100.... | y | 5 | 2344.073 | 14085.15 | 624.421 | 624.421 | 1... | H1-1a |
| 25 | M76 | Pipe 2.0 A2... | .257 | 54.822 | 17 | .235 | 55.424 | 5 | 15885.263 | 23232.186 | 1397.505 | 1397.505 | 1... | H1-1b | |
| 26 | M77 | Pipe 2.0 A2... | .788 | 2.466 | 5 | .250 | 0 | 5 | 5356.594 | 23232.186 | 1397.505 | 1397.505 | 1... | H1-1a | |
| 27 | M78 | 1.5x1.5x0.083 | .867 | 52.42 | 5 | .003 | 0 | y | 4 | 2344.073 | 14085.15 | 624.421 | 624.421 | 1... | H1-1a |
| 28 | M76A | Pipe 2.0 A2... | .234 | 55.424 | 6 | .161 | 55.424 | 5 | 15885.263 | 23232.186 | 1397.505 | 1397.505 | 1... | H1-1b | |
| 29 | M77A | Pipe 2.0 A2... | .541 | 2.466 | 5 | .167 | 0 | 5 | 5356.594 | 23232.186 | 1397.505 | 1397.505 | 1... | H1-1a | |
| 30 | M78A | 1.5x1.5x0.083 | .589 | 52.42 | 5 | .031 | 100.... | y | 11 | 2344.073 | 14085.15 | 624.421 | 624.421 | 1... | H1-1a |
| 31 | M72 | Pipe 2.0 A2... | .253 | 54.822 | 17 | .258 | 55.424 | 5 | 15885.263 | 23232.186 | 1397.505 | 1397.505 | 1... | H1-1b | |
| 32 | M73A | Pipe 2.0 A2... | .851 | 2.466 | 5 | .274 | 0 | 5 | 5356.594 | 23232.186 | 1397.505 | 1397.505 | 1... | H1-1a | |
| 33 | M74A | 1.5x1.5x0.083 | .946 | 52.42 | 5 | .006 | 0 | y | 11 | 2344.073 | 14085.15 | 624.421 | 624.421 | 1... | H1-1a |

Envelope AA ADM1-15: ASD - Building Aluminum Code Checks

| Member | Shape | Code C... | Loc[in] | LC Shear | ... | Loc[in] | Dir | LC Pnc/O... | Pnt/Om... | Mny/O... | Mnz/O... | Vny/O... | Vnz/O... | Cb | Eqn | | |
|--------|-------|-------------|---------|----------|-----|---------|----------|-------------|-----------|----------|-----------|----------|----------|----------|----------|------|-------|
| 1 | M19 | RT1.5x2x... | .059 | 55.055 | 11 | .008 | 0 | z | 6 | 2164.145 | 19411.... | 770.742 | 927.083 | 5889.423 | 3966.346 | 1... | H.1-1 |
| 2 | M16 | HR300 | .708 | 141.4... | 16 | .084 | 141.4... | y | 11 | 3385.295 | 14429.... | 560.361 | 934.132 | 5656.689 | 2605.145 | 1... | H.1-1 |
| 3 | M75B | RT1.5x2x... | .059 | 55.123 | 11 | .008 | 0 | z | 6 | 2158.824 | 19411.... | 770.742 | 927.083 | 5889.423 | 3966.346 | 1... | H.1-1 |
| 4 | M38 | HR300 | .847 | 141.4... | 16 | .087 | 37.714 | y | 12 | 3385.295 | 14429.... | 560.361 | 934.132 | 5656.689 | 2605.145 | 1... | H.1-1 |
| 5 | M41 | HR300 | .612 | 141.4... | 16 | .085 | 37.714 | y | 12 | 3385.295 | 14429.... | 560.361 | 934.132 | 5656.689 | 2605.145 | 1... | H.1-1 |
| 6 | M44 | HR300 | .647 | 141.4... | 16 | .086 | 37.714 | y | 12 | 3385.295 | 14429.... | 560.361 | 934.132 | 5656.689 | 2605.145 | 1... | H.1-1 |
| 7 | M47 | HR300 | .760 | 141.4... | 16 | .085 | 37.714 | y | 12 | 3385.295 | 14429.... | 560.361 | 934.132 | 5656.689 | 2605.145 | 1... | H.1-1 |
| 8 | M50A | HR300 | .719 | 141.4... | 16 | .086 | 37.714 | y | 12 | 3385.295 | 14429.... | 560.361 | 934.132 | 5656.689 | 2605.145 | 1... | H.1-1 |
| 9 | M53 | HR300 | .710 | 141.4... | 16 | .085 | 37.714 | y | 12 | 3385.295 | 14429.... | 560.361 | 934.132 | 5656.689 | 2605.145 | 1... | H.1-1 |
| 10 | M56 | HR300 | .774 | 141.4... | 16 | .086 | 37.714 | y | 12 | 3385.295 | 14429.... | 560.361 | 934.132 | 5656.689 | 2605.145 | 1... | H.1-1 |
| 11 | M59 | HR300 | .630 | 141.4... | 16 | .085 | 37.714 | y | 12 | 3385.295 | 14429.... | 560.361 | 934.132 | 5656.689 | 2605.145 | 1... | H.1-1 |
| 12 | M62 | HR300 | .624 | 141.4... | 16 | .086 | 37.714 | y | 12 | 3385.295 | 14429.... | 560.361 | 934.132 | 5656.689 | 2605.145 | 1... | H.1-1 |
| 13 | M65 | HR300 | .838 | 141.4... | 16 | .086 | 37.714 | y | 12 | 3385.295 | 14429.... | 560.361 | 934.132 | 5656.689 | 2605.145 | 1... | H.1-1 |
| 14 | M68B | HR300 | .715 | 141.4... | 16 | .085 | 141.4... | y | 11 | 3385.295 | 14429.... | 560.361 | 934.132 | 5656.689 | 2605.145 | 1... | H.1-1 |
| 15 | M74B | HR300 | .559 | 35.829 | 6 | .078 | 37.714 | y | 12 | 6408.62 | 14429.... | 560.361 | 934.132 | 5656.689 | 2605.145 | 2... | H.1-1 |
| 16 | M77B | HR300 | .688 | 141.4... | 16 | .073 | 141.4... | y | 11 | 3385.295 | 14429.... | 560.361 | 934.132 | 5656.689 | 2605.145 | 1... | H.1-1 |
| 17 | M80A | HR300 | .565 | 141.4... | 16 | .073 | 37.714 | y | 12 | 3385.295 | 14429.... | 560.361 | 934.132 | 5656.689 | 2605.145 | 1... | H.1-1 |
| 18 | M83 | HR300 | .560 | 141.4... | 16 | .073 | 37.714 | y | 12 | 3385.295 | 14429.... | 560.361 | 934.132 | 5656.689 | 2605.145 | 1... | H.1-1 |
| 19 | M86 | HR300 | .693 | 141.4... | 16 | .073 | 37.714 | y | 12 | 3385.295 | 14429.... | 560.361 | 934.132 | 5656.689 | 2605.145 | 1... | H.1-1 |
| 20 | M89 | HR300 | .558 | 35.829 | 6 | .078 | 37.714 | y | 12 | 6408.62 | 14429.... | 560.361 | 934.132 | 5656.689 | 2605.145 | 2... | H.1-1 |

NOTES: UNLESS OTHERWISE SPECIFIED
 1. DIMENSIONS SHOWN ARE INCHES [MILLIMETERS].

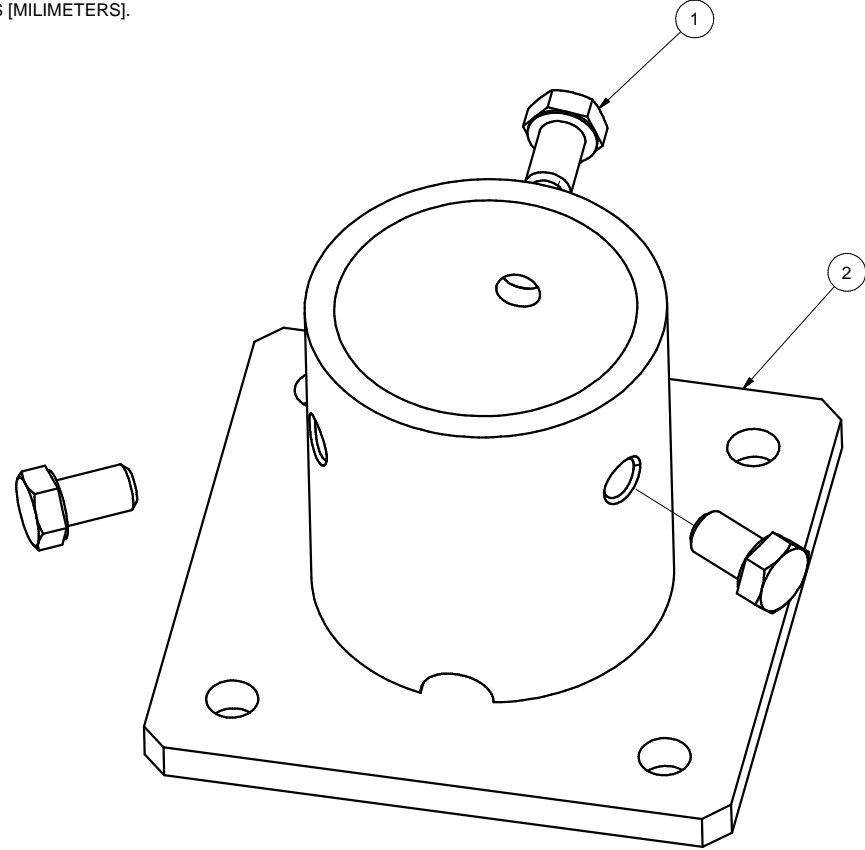

| REVISIONS | | | |
|-----------|-----------------|-----|------------|
| REV | DESCRIPTION | BY | DATE |
| A | INITIAL RELEASE | LWF | 10/20/2016 |

| 2 | A21120-001 | 2" PIPE BASE | 1 |
|-------------------------|-------------|---|-----|
| 1 | B15018-011 | HEX CAP SCREW 3/8-16 X 5/8 | 3 |
| ITEM | PART NUMBER | DESCRIPTION | QTY |
| MATERIAL | | SEE NOTES | |
| Third Angle Projection: | | | |
| GENERAL SPECIFICATIONS | | Sunmodo Corp. 1905 E 5TH STREET, STE A, VANCOUVER, WA 98661 | |
| Tolerances | | TITLE | |
| X.XXX ±0.01 [0.25mm] | | 2" PIPE BASE KIT | |
| X.XX ±0.02 [0.50mm] | | DRAWING NUMBER | |
| X.X ±0.039 [1.0mm] | | B K10268-001 | |
| Unless otherwise spec'd | | SCALE: NONE | |
| DRAWN BY | | SHEET 1 of 1 | |
| LWF | | DATE | |
| CHECKED BY | | 10/20/2016 | |
| APPROVALS | | | |

THIS DRAWING IS CONFIDENTIAL PROPERTY OF SUNMODO AND ITS CONTENTS MAY NOT BE DISCLOSED WITHOUT THE PRIOR WRITTEN CONSENT OF SUNMODO CORP.

NOTES: UNLESS OTHERWISE SPECIFIED

1. DIMENSIONS SHOWN ARE INCHES [MILIMETERS].
2. MATERIAL: ALUMINUM 6005-T5.
FINISH: CLEAR ANODIZED 10 μ m THICK.
3. THE UNSPECIFIED DIMENSIONS ARE SPECIFIED BY 2D CAD FILE.

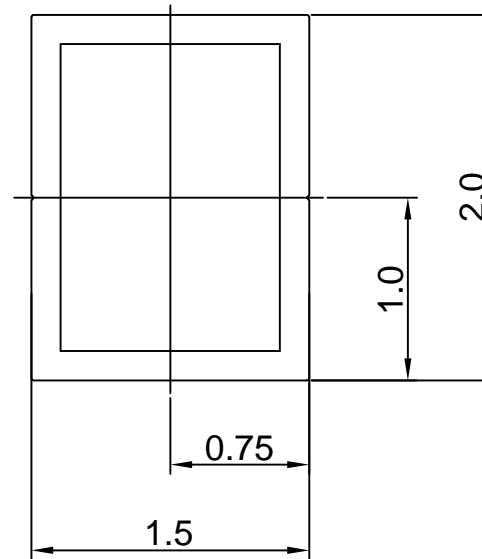

Section properties:

Weight: 1.156 lbs/ft

Area: 0.992 in²

Perimeter: 12.601 in

Bounding Box: X: -1.000,1.000

Y: -0.750, 0.750

Centroid:(0.000,0.000)

Moments of Inertia(in⁴): I_x=0.506,I_y=0.322

Section modulus in bending(in³): W_x=0.675,W_y=0.322

Radii of Gyration: X: 0.714, Y: 0.570

| | | | |
|--|-----------------------|---|--|
| MATERIAL | | SEE NOTES | |
| Third Angle Projection: | | | |
| GENERAL SPECIFICATIONS | | | |
| All Dimensions in inches [millimeters] | | | |
| Tolerances | | | |
| X.XXX ± 0.01 [0.25mm] | Break all sharp edges | | |
| X.XX ± 0.02 [0.50mm] | .010-.020 unless | | |
| X.X ± 0.039 [1.0mm] | otherwise specified. | | |
| DRAWN BY | | DATE | |
| zcg | | 03/12/2014 | |
| CHECKED BY | | | |
| APPROVALS | | | |
| | | 1905 E 5TH STREET, SUITE A, VANCOUVER, WA 98661 | |
| | | TITLE | |
| | | 1.5X2 AL TUBE BRACE EXTRUSION | |
| | | DRAWING NUMBER | |
| | | A20164 | |
| | | SCALE: NONE | |
| | | SHEET 1 of 1 | |

| REVISIONS | | | |
|-----------|---|-----|------------|
| REV | DESCRIPTION | BY | DATE |
| A | ADDED BOTTOM CHANNEL & CHANGED ONE 3/8 CHANNEL TO 1/4 | zcg | 02/21/2013 |

NOTES: UNLESS OTHERWISE SPECIFIED

- DIMENSIONS SHOWN ARE INCHES [MILIMETERS].
- MATERIAL: ALUMINUM 6005-T5.
FINISH: CLEAR ANODIZED 15 μm THICK.
- THE UNSPECIFIED DIMENSIONS ARE SPECIFIED BY 2D CAD FILE.

2X 1/4 BOLT SLOT

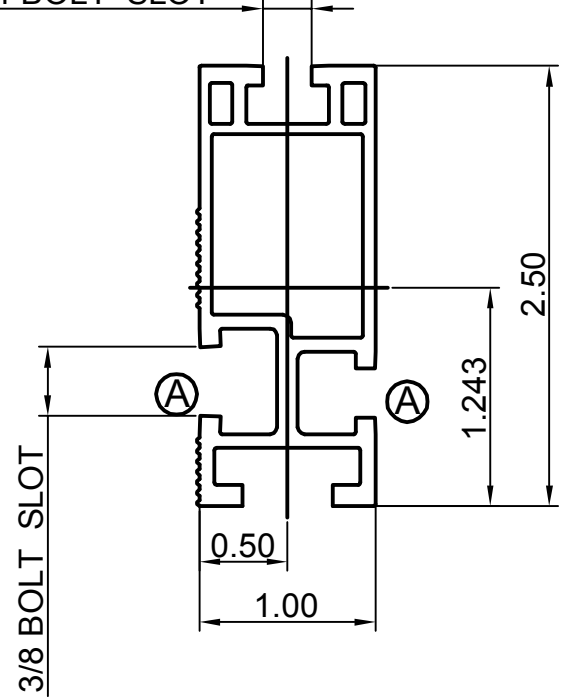

Section properties:

Weight: 0.850 lbs/ft
 Area: 0.723 in²
 Perimeter: 17.325 in
 Bounding Box: X: -0.500,0.500
 Y: -1.243,1.257

Centroid:(0.000,0.000)
 Moments of Inertia(in⁴): I_x=0.486,I_y=0.095
 Section modulus in bending(in³): W_x=0.387,W_y=0.190
 Radii of Gyration: X: 0.820, Y: 0.363

| | |
|--|-----------------------|
| MATERIAL SEE NOTES | |
| Third Angle Projection: | |
| GENERAL SPECIFICATIONS All Dimensions in inches [millimeters] | |
| Tolerances | |
| X.XXX ± 0.01 [0.25mm] | Break all sharp edges |
| X.XX ± 0.02 [0.50mm] | .010-.020 unless |
| X.X ± 0.039 [1.0mm] | otherwise specified. |
| DRAWN BY zcg | DATE 02/21/2013 |
| CHECKED BY | |
| APPROVALS | |

| | |
|---|--------------------------|
| Sunmodo Corp. | |
| 1905 E 5TH STREET, SUITE A, VANCOUVER, WA 98661 | |
| TITLE HELIO STANDARD RAIL | |
| B | DRAWING NUMBER A20144 |
| SCALE: NONE | SHEET 1 of 1 |

NOTES: UNLESS OTHERWISE SPECIFIED

1. DIMENSIONS SHOWN ARE INCHES [MILIMETERS].
2. MATERIAL: 6005-T5.
FINISH: CLEAR ANODIZED 10um THICK.
3. THE UNSPECIFIED RADII ARE .02" MAX.
4. THE UNSPECIFIED DIMENSIONS ARE SPECIFIED BY 2D CAD FILE.

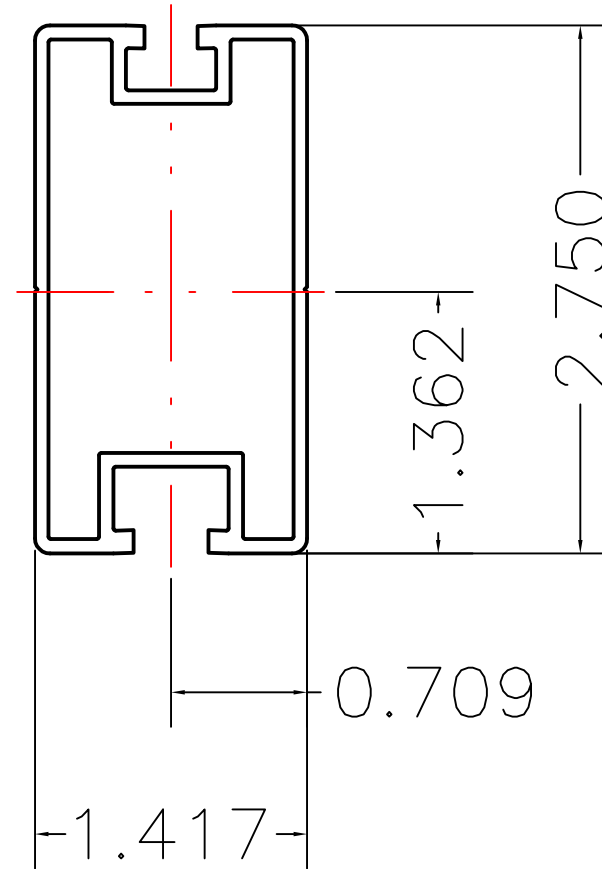

Section properties:

Weight: 0.862 lbs/ft
 Area: 0.736 in²
 Perimeter: 19.824 in
 Bounding Box: X: -0.709,0.709
 Y: -1.362,1.388
 Centroid:(0.000,0.000)
 Moments of Inertia(in⁴): I_x=0.727,I_y=0.214
 Section modulus in bending(in³): W_x=0.524,W_y=0.302
 Radii of Gyration: X: 994, Y: 0.539

THIS DRAWING IS CONFIDENTIAL PROPERTY OF SUNMODO AND ITS CONTENTS MAY NOT BE DISCLOSED WITHOUT THE PRIOR WRITTEN CONSENT OF SUNMODO CORP.

| | |
|--|-----------------------|
| MATERIAL SEE NOTES | |
| Third Angle Projection: | |
| GENERAL SPECIFICATIONS All Dimensions in inches [millimeters] | |
| Tolerances | |
| X.XXX ±0.01 [0.25mm] | Break all sharp edges |
| X.XX ±0.02 [0.50mm] | .010-.020 unless |
| X.X ±0.039 [1.0mm] | otherwise specified. |
| Unless otherwise spec'd | |
| DRAWN BY KYY | DATE 01/18/2018 |
| CHECKED BY | |
| APPROVALS | |

| | |
|--|--------------------------|
| SunModo Corp. | |
| 14800 NE 65TH STREET, VANCOUVER WA 98682 | |
| TITLE RAIL, HR300 (SUNRAY), EXTRUSION | |
| B | DRAWING NUMBER A20288 |
| SCALE: NONE | SHEET 1 of 1 |

| REV | DESCRIPTON | BY | DATE |
|-----|------------------------------|-----|------------|
| A | 0.44 WAS 0.41, 0.44 WAS 0.33 | LWF | 11/30/2015 |

NOTES: UNLESS OTHERWISE SPECIFIED

- 1. DIMENSIONS SHOWN ARE INCHES [MILIMETERS].
- 2. MATERIAL: ALUMINUM 6005-T5.
FINISH: CLEAR ANODIZED 15 μm THICK.
- 3. THE UNSPECIFIED DIMENSIONS ARE SPECIFIED BY 2D CAD FILE.

2X 1/4 BOLT SLOT

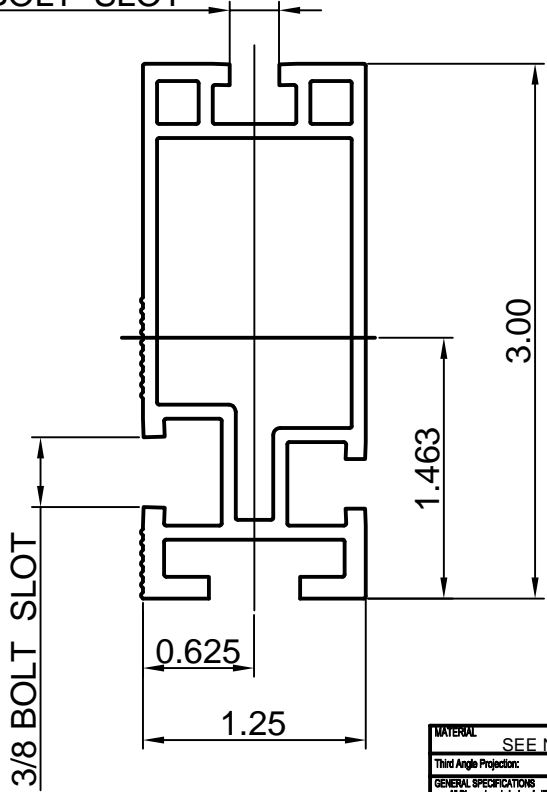

Section properties:

Weight: 1.151 lbs/ft
 Area: 0.980 in²
 Perimeter: 22.104 in
 Bounding Box: X: -0.625,0.625
 Y: -1.463,1.537
 Centroid:(0.000,0.000)
 Moments of Inertia(in⁴): Ix=1.047,Iy=0.207
 Section modulus in bending(in³): Wx=0.681,Wy=0.331
 Radii of Gyration: X: 1.034, Y: 0.460

| | | | |
|---|--|----------------|--|
| MATERIAL | | SEE NOTES | |
| Third Angle Projection | | | |
| GENERAL SPECIFICATIONS | | | |
| All Dimensions in Inches (millimeters) | | | |
| Tolerances | | | |
| XXX ±0.01 (0.25mm) | | | |
| XX ±0.02 (0.50mm) | | | |
| X ±0.03 (1.0mm) | | | |
| Unless otherwise specified. | | | |
| Break all sharp edges 0.10-0.25 unless otherwise specified. | | | |
| DRAWN BY | | DATE | |
| ZCG | | 02/21/2015 | |
| CHECKED BY | | B | |
| APPROVALS | | DRAWING NUMBER | |
| | | A20145 | |
| SCALE: | | SHEET | |
| NONE | | 1 of 1 | |

Sunmodo Corp.

1905 E 5TH STREET, SUITE A, VANCOUVER, WA 98661

HELIO HEAVY RAIL

DRAWING NUMBER
A20145

SCALE: NONE SHEET 1 of 1

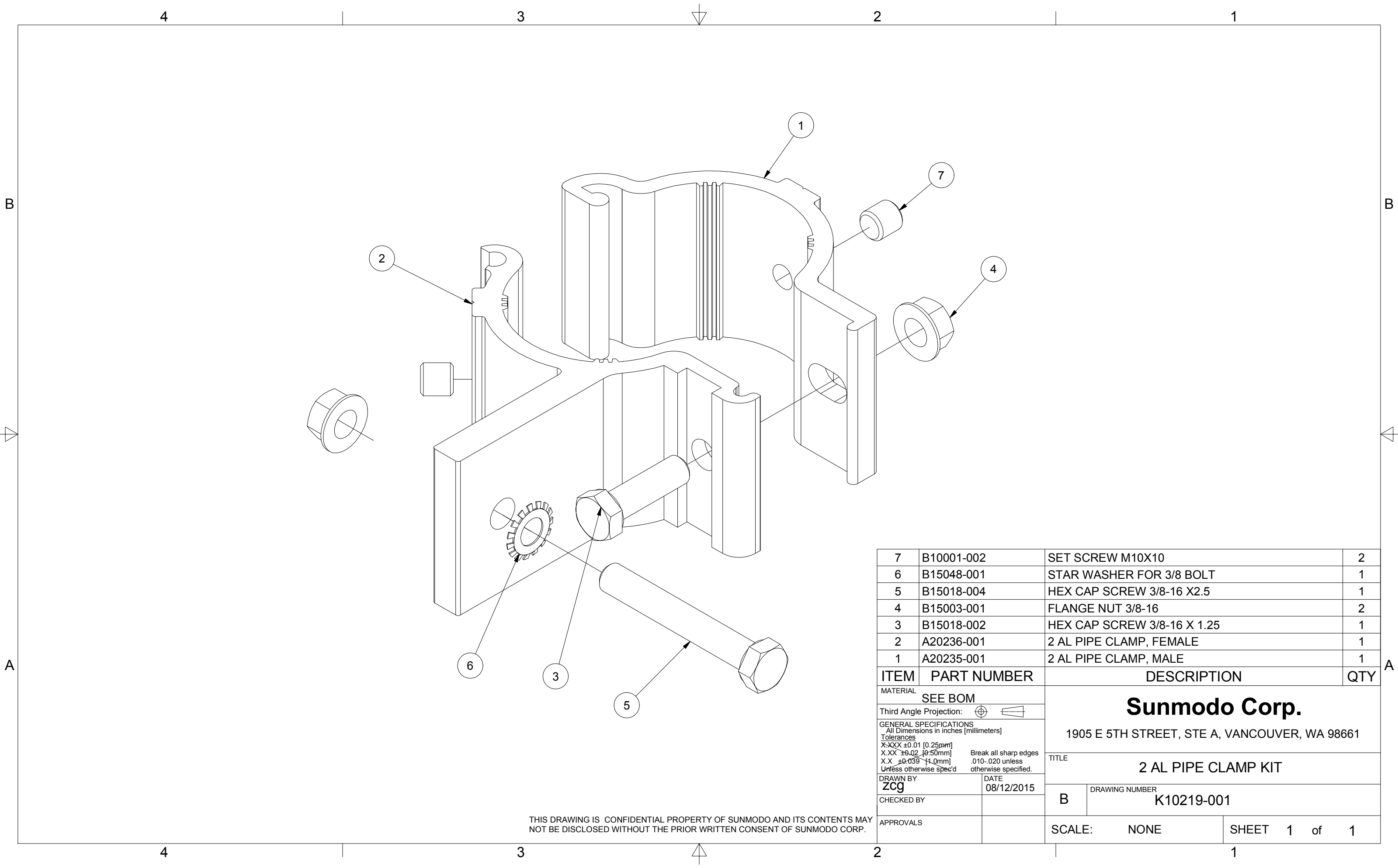

| | | | |
|---|------------|-----------------------------|---|
| 7 | B10001-002 | SET SCREW M10X10 | 2 |
| 6 | B15048-001 | STAR WASHER FOR 3/8 BOLT | 1 |
| 5 | B15018-004 | HEX CAP SCREW 3/8-16 X2.5 | 1 |
| 4 | B15003-001 | FLANGE NUT 3/8-16 | 2 |
| 3 | B15018-002 | HEX CAP SCREW 3/8-16 X 1.25 | 1 |
| 2 | A20236-001 | 2 AL PIPE CLAMP, FEMALE | 1 |
| 1 | A20235-001 | 2 AL PIPE CLAMP, MALE | 1 |

| ITEM | PART NUMBER | DESCRIPTION | QTY |
|--|-------------|-----------------------|--------------|
| MATERIAL | | SEE BOM | |
| Third Angle Projection: | | | |
| GENERAL SPECIFICATIONS All Dimensions in inches (millimeters) | | | |
| Tolerances | | | |
| X.XXX ±0.01 [0.25mm] | | Break all sharp edges | |
| X.XX ±0.02 [0.50mm] | | .010-.020 unless | |
| X.X ±0.039 [1.0mm] | | otherwise specified. | |
| DRAWN BY | | DATE | |
| zcg | | 08/12/2015 | |
| CHECKED BY | | TITLE | |
| | | 2 AL PIPE CLAMP KIT | |
| APPROVALS | | DRAWING NUMBER | |
| | | B K10219-001 | |
| SCALE: | | NONE | SHEET 1 of 1 |

THIS DRAWING IS CONFIDENTIAL PROPERTY OF SUNMODO AND ITS CONTENTS MAY NOT BE DISCLOSED WITHOUT THE PRIOR WRITTEN CONSENT OF SUNMODO CORP.

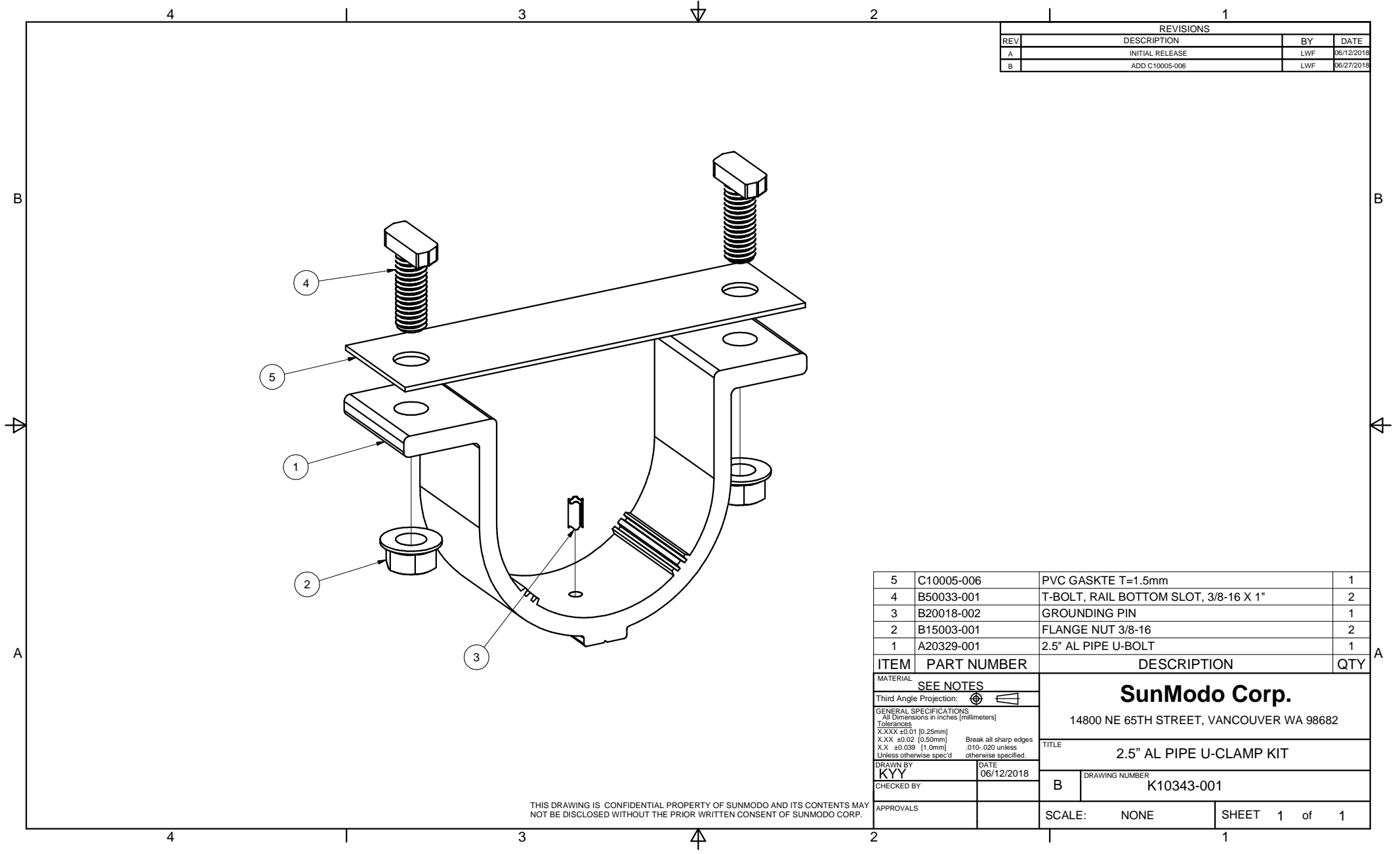

| REVISIONS | | | |
|-----------|-----------------|-----|------------|
| REV | DESCRIPTION | BY | DATE |
| A | INITIAL RELEASE | LWF | 06/12/2018 |
| B | ADD C10005-006 | LWF | 06/27/2018 |

| ITEM | PART NUMBER | DESCRIPTION | QTY |
|------|-------------|---------------------------------------|-----|
| 5 | C10005-006 | PVC GASKTE T=1.5mm | 1 |
| 4 | B50033-001 | T-BOLT, RAIL BOTTOM SLOT, 3/8-16 X 1" | 2 |
| 3 | B20018-002 | GROUNDING PIN | 1 |
| 2 | B15003-001 | FLANGE NUT 3/8-16 | 2 |
| 1 | A20329-001 | 2.5" AL PIPE U-BOLT | 1 |

| | | | |
|--|------------|--|--------------|
| MATERIAL | | SEE NOTES | |
| Third Angle Projection: | | | |
| GENERAL SPECIFICATIONS | | <p>SunModo Corp. 14800 NE 65TH STREET, VANCOUVER WA 98682</p> | |
| All Dimensions in inches [millimeters] Tolerances X.XXX ±0.01 [0.25mm] X.XX ±0.02 [0.50mm] X.X ±0.039 [1.0mm] Unless otherwise spec'd | | | |
| TITLE | | 2.5" AL PIPE U-CLAMP KIT | |
| DRAWN BY | DATE | DRAWING NUMBER | |
| KYY | 06/12/2018 | B K10343-001 | |
| CHECKED BY | | | |
| APPROVALS | | SCALE: NONE | SHEET 1 of 1 |

THIS DRAWING IS CONFIDENTIAL PROPERTY OF SUNMODO AND ITS CONTENTS MAY NOT BE DISCLOSED WITHOUT THE PRIOR WRITTEN CONSENT OF SUNMODO CORP.

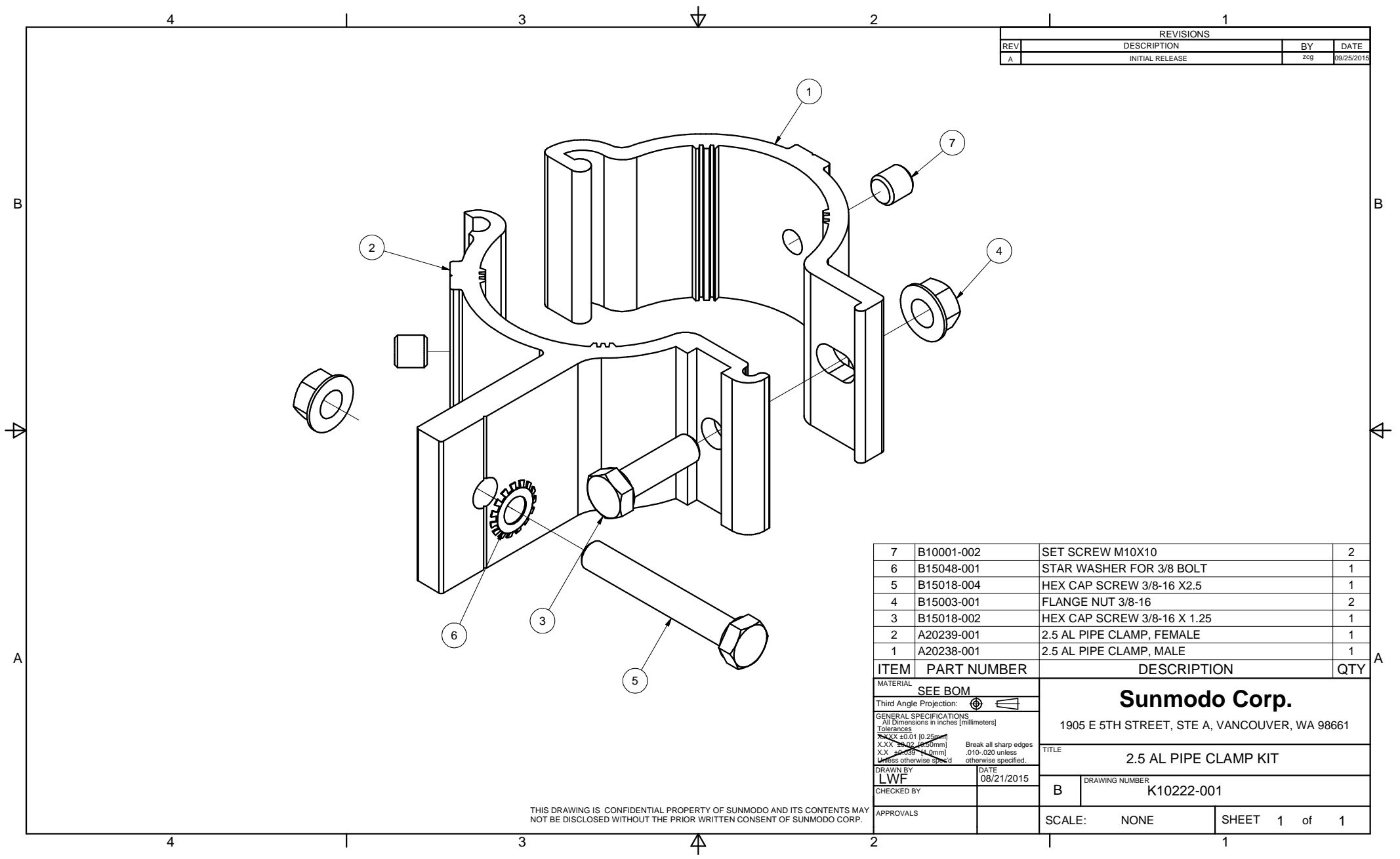

| REVISIONS | | | |
|-----------|-----------------|-----|------------|
| REV | DESCRIPTION | BY | DATE |
| A | INITIAL RELEASE | zcg | 09/25/2015 |

| ITEM | PART NUMBER | DESCRIPTION | QTY |
|------|-------------|-----------------------------|-----|
| 7 | B10001-002 | SET SCREW M10X10 | 2 |
| 6 | B15048-001 | STAR WASHER FOR 3/8 BOLT | 1 |
| 5 | B15018-004 | HEX CAP SCREW 3/8-16 X2.5 | 1 |
| 4 | B15003-001 | FLANGE NUT 3/8-16 | 2 |
| 3 | B15018-002 | HEX CAP SCREW 3/8-16 X 1.25 | 1 |
| 2 | A20239-001 | 2.5 AL PIPE CLAMP, FEMALE | 1 |
| 1 | A20238-001 | 2.5 AL PIPE CLAMP, MALE | 1 |

| | | | |
|---|--|----------------|--|
| MATERIAL | | SEE BOM | |
| Third Angle Projection: | | | |
| GENERAL SPECIFICATIONS All Dimensions in inches [millimeters] Tolerances X.XX ±0.01 (0.25mm) X.X ±0.02 (0.5mm) X.X ±0.03 (0.75mm) Unless otherwise specified. | | | |
| DRAWN BY | | DATE | |
| LWF | | 08/21/2015 | |
| CHECKED BY | | B | |
| APPROVALS | | SCALE: NONE | |
| | | SHEET 1 of 1 | |

Sunmodo Corp.
 1905 E 5TH STREET, STE A, VANCOUVER, WA 98661

TITLE: **2.5 AL PIPE CLAMP KIT**

DRAWING NUMBER: **K10222-001**

THIS DRAWING IS CONFIDENTIAL PROPERTY OF SUNMODO AND ITS CONTENTS MAY NOT BE DISCLOSED WITHOUT THE PRIOR WRITTEN CONSENT OF SUNMODO CORP.

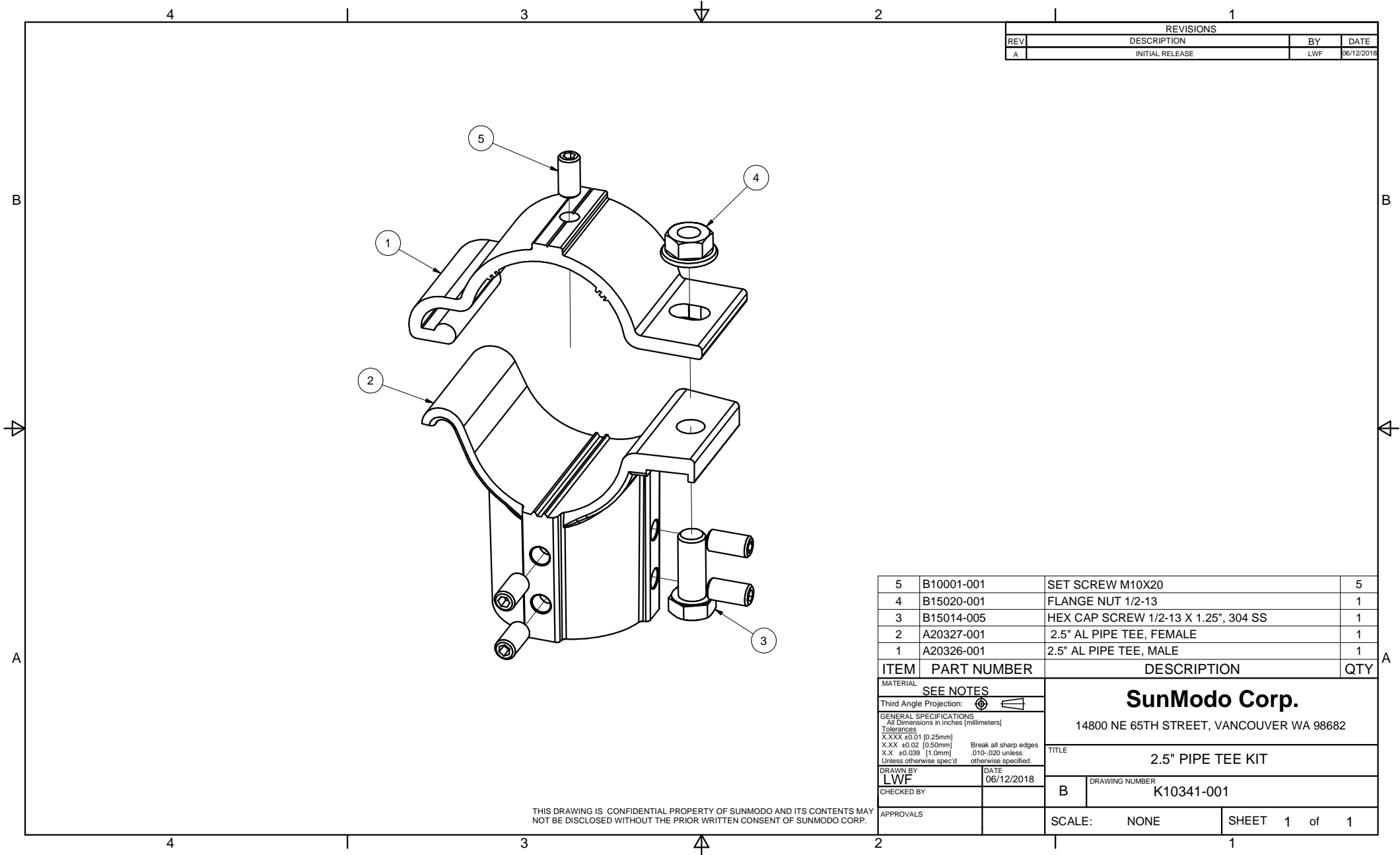

| REVISIONS | | | |
|-----------|-----------------|-----|------------|
| REV | DESCRIPTION | BY | DATE |
| A | INITIAL RELEASE | LWF | 06/12/2018 |

| 5 | B10001-001 | SET SCREW M10X20 | 5 |
|------|-------------|--------------------------------------|-----|
| 4 | B15020-001 | FLANGE NUT 1/2-13 | 1 |
| 3 | B15014-005 | HEX CAP SCREW 1/2-13 X 1.25", 304 SS | 1 |
| 2 | A20327-001 | 2.5" AL PIPE TEE, FEMALE | 1 |
| 1 | A20326-001 | 2.5" AL PIPE TEE, MALE | 1 |
| ITEM | PART NUMBER | DESCRIPTION | QTY |

| | | | |
|--|--|--|--|
| MATERIAL | | SEE NOTES | |
| Third Angle Projection: | | | |
| GENERAL SPECIFICATIONS | | SunModo Corp. 14800 NE 65TH STREET, VANCOUVER WA 98682 | |
| Tolerances | | TITLE | |
| X.XXX ±0.01 [0.25mm] X.XX ±0.02 [0.50mm] X.X ±0.039 [1.0mm] Unless otherwise spec'd | | 2.5" PIPE TEE KIT | |
| DRAWN BY | | DATE | |
| LWF | | 06/12/2018 | |
| CHECKED BY | | DRAWING NUMBER | |
| | | B K10341-001 | |
| APPROVALS | | SCALE: NONE SHEET 1 of 1 | |

THIS DRAWING IS CONFIDENTIAL PROPERTY OF SUNMODO AND ITS CONTENTS MAY NOT BE DISCLOSED WITHOUT THE PRIOR WRITTEN CONSENT OF SUNMODO CORP.

| REVISIONS | | | |
|-----------|-----------------|-----|------------|
| REV | DESCRIPTION | BY | DATE |
| A | INITIAL RELEASE | LWF | 06/12/2018 |

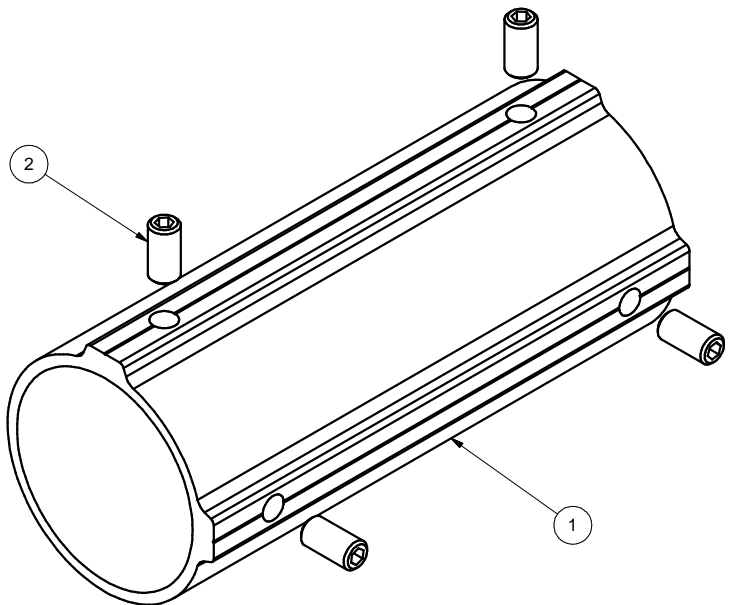

| 2 | B10001-001 | SET SCREW M10X20 | 4 |
|--|-------------|---|-----|
| 1 | A20328-001 | 2.5" PIPE SPLICE | 1 |
| ITEM | PART NUMBER | DESCRIPTION | QTY |
| MATERIAL | | SEE NOTES | |
| Third Angle Projection: | | | |
| GENERAL SPECIFICATIONS | | SunModo Corp. 14800 NE 65TH STREET, VANCOUVER WA 98682 | |
| All Dimensions in inches [millimeters] Tolerances X.XXX ±0.01 [0.25mm] X.XX ±0.02 [0.50mm] X.X ±0.039 [1.0mm] Unless otherwise spec'd | | Break all sharp edges .010-.020 unless otherwise specified. | |
| DRAWN BY | | TITLE | |
| LWF | | 2.5" PIPE SPLICE KIT | |
| CHECKED BY | | DRAWING NUMBER | |
| | | B K10342-001 | |
| APPROVALS | | SCALE: NONE SHEET 1 of 1 | |

THIS DRAWING IS CONFIDENTIAL PROPERTY OF SUNMODO AND ITS CONTENTS MAY NOT BE DISCLOSED WITHOUT THE PRIOR WRITTEN CONSENT OF SUNMODO CORP.

NOTES: UNLESS OTHERWISE SPECIFIED

1. DIMENSIONS SHOWN ARE INCHES [MILIMETERS].
2. MATERIAL:HIGH STRENGTH STEEL PIPE OR TUBE.
3. FINISH: HOT DIP GALVANIZE PER ASTM A123 / A123M - 02.

MINIMUM 50 KSI YIELD STRESS.

4. BREAK ALL BURRS AND SHARP EDGES.

5. ALL WELDING MUST BE IN COMPLIANCE WITH AWS CODE D1;1.

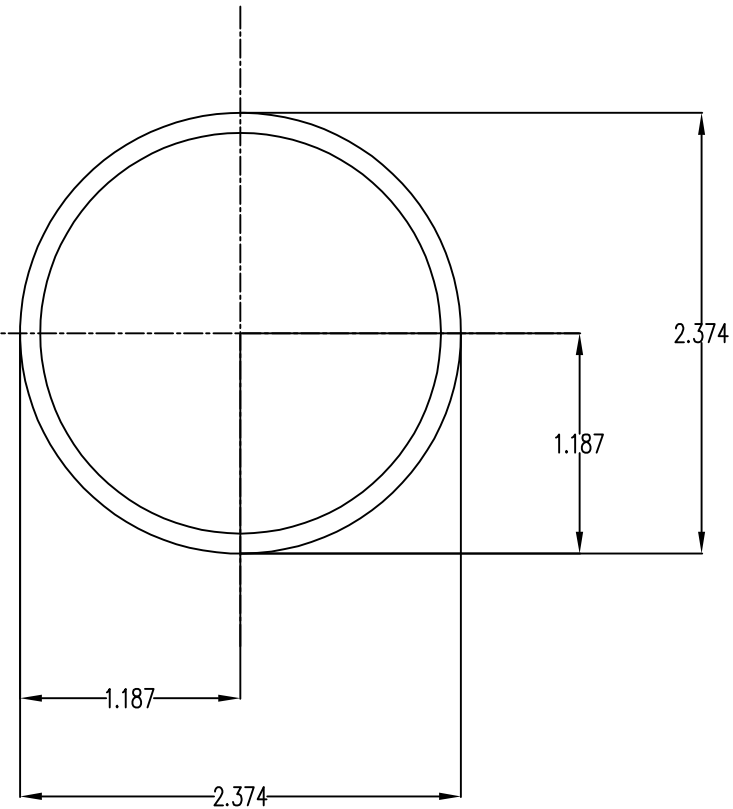

Section properties:

Weight: 2.641 lbs/ft

Area: 0.776 in²

Perimeter: 14.238 in

Bounding Box: X: -1.187,1.187

Y: -1.187,1.187

Centroid:(0.000,0.000)

Moments of Inertia(in⁴): Ix=0.499,Iy=0.499

Section modulus in bending(in³): Wx=0.420,Wy=0.420

Radii of Gyration: X: 0.802, Y: 0.802

| | | | | | |
|--|------------|-----------|--|--|--|
| MATERIAL | | SEE NOTES | | Sunmodo Corp. 14800 NE 85TH STREET, VANCOUVER WA 98682 | |
| Third Angle Projection: | | | | | |
| GENERAL SPECIFICATIONS | | | | TITLE | |
| All Dimensions in Inches (millimeters) | | | | PIPE, HSS, 2.375" OD X 12 GAUGE,L=XXX | |
| Tolerances | | | | Break all sharp edges .010-.020 unless otherwise specified. | |
| XXX ±0.01 (0.25mm) | | | | | |
| XX ±0.02 (0.50mm) | | | | | |
| X ±0.050 (1.27mm) | | | | | |
| Unless otherwise specified | | | | | |
| DRAWN BY | DATE | B | | DRAWING NUMBER | |
| LWF | 04/03/2019 | | | A21165 | |
| CHECKED BY | | | | | |
| APPROVALS | | | | SCALE: NONE SHEET 1 of 1 | |

NOTES: UNLESS OTHERWISE SPECIFIED

1. DIMENSIONS SHOWN ARE INCHES [MILIMETERS].
2. MATERAIL:HIGH STRENGTH STEEL PIPE OR TUBE.
3. FINISH: HOT DIP GALVANIZE PER ASTM A123 / A123M - 02.

MINIMUM 50 KSI YIELD STRESS.

4. BREAK ALL BURRS AND SHARP EDGES.
5. ALL WELDING MUST BE IN COMPLIANCE WITH AWS CODE D1;1.

Section properties:

Weight: 3.201 lbs/ft

Area: 0.941 in²

Perimeter: 17.378 in

Bounding Box: X: -1.437,1.437

Y: -1.437,1.437

Centroid:(0.000,0.000)

Moments of Inertia(in⁴): Ix=0.901,Iy=0.901

Section modulus in bending(in³): Wx=0.627,Wy=0.627

Radii of Gyration: X: 0.979, Y: 0.979

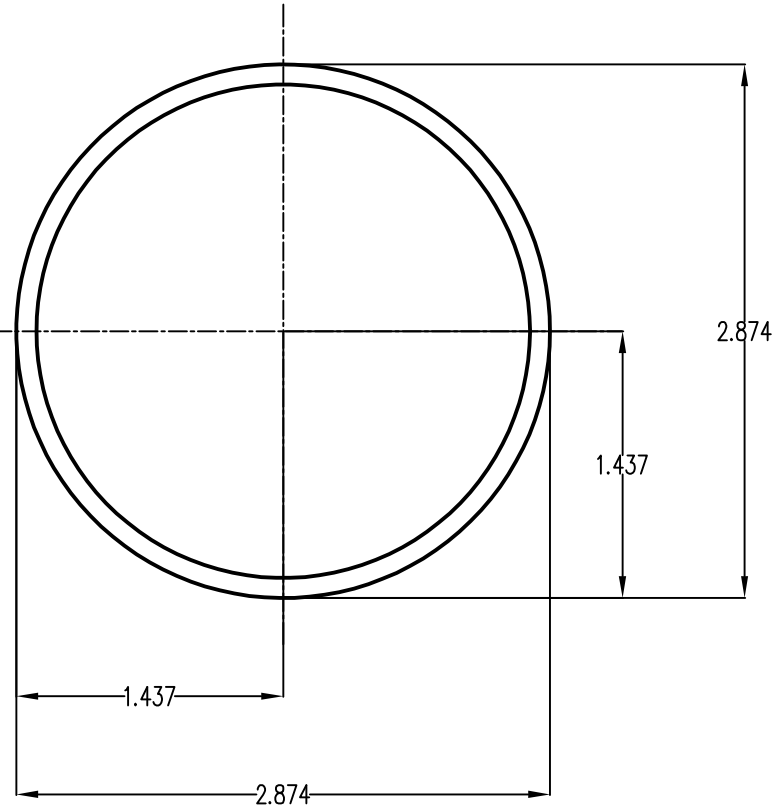

| | | | | | |
|---|--|--------------------|--|--|--|
| MATERIAL | | SEE NOTES | | Sunmodo Corp. 14800 NE 85TH STREET, VANCOUVER WA 98682 | |
| Third Angle Projection: | | | | | |
| GENERAL SPECIFICATIONS All Dimensions in Inches (millimeters) | | | | TITLE | |
| Tolerances XXX ±0.01 (0.25mm) XX ±0.02 (0.50mm) X ±0.030 (1.0mm) Unless otherwise specified | | | | PIPE, HSS, 2.875" OD X 12 GAUGE,L=XXX | |
| DRAWN BY LWF | | DATE 04/03/2019 | | DRAWING NUMBER A21168 | |
| CHECKED BY | | | | B | |
| APPROVALS | | | | SCALE: NONE SHEET 1 of 1 | |