

NOTES: UNLESS OTHERWISE SPECIFIED

- THIS DRAWING IS NOT FOR CONSTRUCTION UNTIL ENGINEERING HAS REVIEWED AND STAMPED THIS DOCUMENT.
- DIMENSIONS SHOWN ARE INCHES.
- THE SELF-BONDING SYSTEM AND SINGLE GROUND LUG IS FOR USE WITH PV MODULES THAT HAVE A MAXIMUM SERIES FUSE RATING OF 30A.
- MATERIALS ARE AS SPECIFIED OR EQUIVALENT:
HARDWARE: 304 STAINLESS STEEL
FABRICATED EXTRUDED PARTS: 6005-T5 ALUMINUM ALLOY
FABRICATED DIE CAST PARTS: ANSI/AA A380 ALUMINUM ALLOY
STEEL PIPE: SCHEDULE 40 GALVANIZED
ALUMINUM PIPE: SCHEDULE 10 ANODIZED
- THE MAXIMUM PERMISSIBLE LENGTH OF ANY STRUCTURE SHALL BE 200 FT. FOR SYSTEMS USING A SHARED RAIL CONFIGURATION, A THERMAL BREAK IS REQUIRED IN THE RAIL EVERY 40 FT. PER THE DRAWING DETAILS.
- 4LXN-3LXN-2PXN-35DEG-GSM-AGM-BGM-PGM.
- PANEL DIMENSIONS ARE AS FOLLOWS
STANDARD (SP): MAX 82"X42"
OVERSIZE (OP): MAX 85"X45"
- APPROVED RAIL PROFILES - STANDARD PANELS
A20288-XXX (HR300 RAIL), A20297-001 (END CAP), K10343-002 (U-CLAMP KIT);
A20145-XXX (HR350 RAIL), A20285-001 (END CAP), K10343-001 (U-CLAMP KIT).
- APPROVED RAIL PROFILES - OVERSIZE PANELS
* A20288-XXX (HR300 RAIL), A20297-001 (END CAP), K10343-002 (U-CLAMP KIT);
* A20145-XXX (HR350 RAIL), A20285-001 (END CAP), K10343-001 (U-CLAMP KIT).
- K10224-XXX END CLAMP KIT OR K10299-XXX ADJ. END CLAMP KIT.
- FOUNDATION TYPES:
GSM = GROUND SCREW GROUND MOUNT
AGM = HELICAL AUGER GROUND MOUNT
PGM = POST-IN-CONCRETE GROUND MOUNT
BSM = BALLAST GROUND MOUNT

VSE Project Number: U2716-114-191

Vector Structural Engineering requires that we review each site-specific install, and we are not liable for installs at site-specific locations we have not reviewed. This document does not address site-specific installations.

Packet A5

| | |
|-------------------|-------------------|
| Model Code | ASCE 7-10 |
| Exposure Category | B and Lower |
| Wind Speed | 140 mph and Lower |
| Ground Snow Load | 70 PSF and Lower |
| Tilt | 35 DEG and Lower |

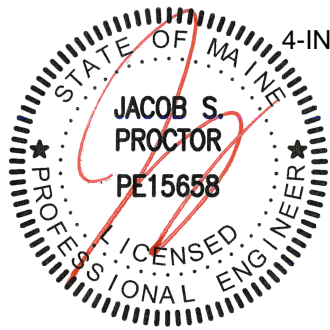
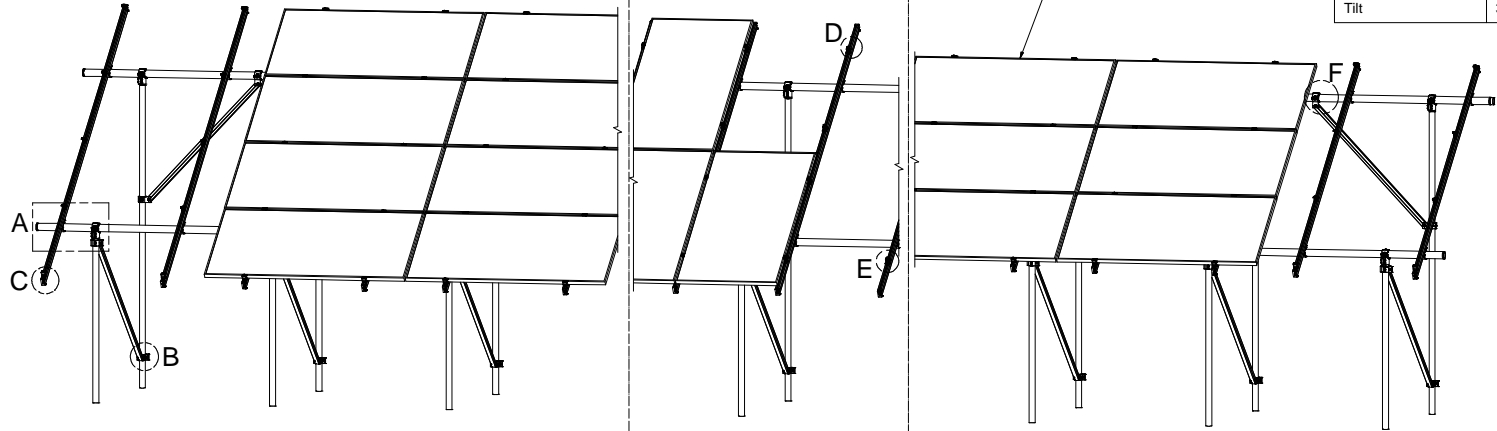

4L
4-IN-LANDSCAPE
02/21/2024

2P
2-IN-PROTRAIT

3L
3-IN-LANDSCAPE

STRUCTURAL ONLY
VECTOR
ENGINEERS

651 W. GALENA PARK BLVD. STE. 101 DRAPER, UTAH 84020
PHONE (801) 990-1775
WWW.VECTORSE.COM

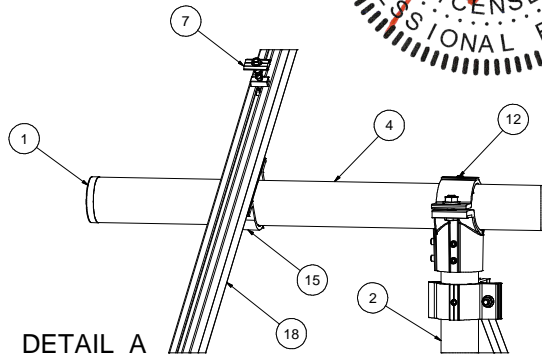

DETAIL A

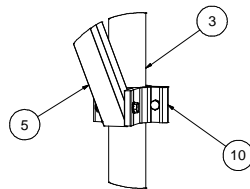

DETAIL B

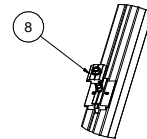

DETAIL D

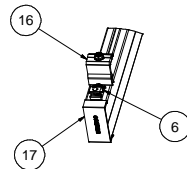

DETAIL C

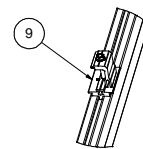

DETAIL E

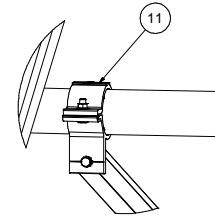

DETAIL F

| ITEM | PART NUMBER | DESCRIPTION | QTY |
|------|--------------------|---|-----|
| 19 | | PANEL | |
| 18 | | HELIO-RAIL-VARIES PER NOTE 8 & 9 | |
| 17 | | HELIO-RAIL END CAP-VARIES PER NOTE 8 & 9 | |
| 16 | | END CLAMP KIT. VARIES PER NOTE 10 | |
| 15 | K10343-001 | 2.5" AL PIPE U-CLAMP KIT | |
| 14 | K10448-001 | 2.5" PIPE SPLICE KIT | |
| 13 | K10342-001 | 2.5" PIPE SPLICE KIT | |
| 12 | K10341-001 | 2.5" PIPE TEE KIT | |
| 11 | K10222-001 | 2.5" PIPE CLAMP KIT | |
| 10 | K10219-001 | 2" AL PIPE CLAMP KIT | |
| 9 | K10183-XXX | LANDSCAPE GROUNDING END CLAMP KIT | |
| 8 | K10182-001 | LANDSCAPE GROUNDING MID CLAMP KIT | |
| 7 | K10180-001 | GROUNDING MID-CLAMP KIT WITH T COLLAR BOLT AND GROUNDING BASE | |
| 6 | K10179-001 | SELF-GROUNDING LUG KIT | |
| 5 | A50164-XXX | 1.5" SQ. STL TUBE BRACE, L=XXX | |
| 4 | A21168-XXX | PIPE, HSS, 2.875" OD X 12 GAUGE, L=XXX | |
| 3 | A21165-XXX (REAR) | PIPE, HSS, 2.375" OD X 12 GAUGE, L=XXX | |
| 2 | A21165-XXX (FRONT) | PIPE, HSS, 2.375" OD X 12 GAUGE, L=XXX | |
| 1 | A20380-001 | 2.5" PIPE END CAP | |

| | |
|--|------------------|
| SEE BOM | |
| Third Angle Projection | |
| PERSONAL USE ONLY (Not for Redistribution) | |
| DATE: 02/21/2024 | TIME: 09:00 AM |
| BY: [Signature] | CHK: [Signature] |
| APP: [Signature] | DATE: 02/21/2024 |
| CHK: [Signature] | DATE: 02/21/2024 |
| APP: [Signature] | DATE: 02/21/2024 |

| | |
|--|----------------|
| SunModo Corp. | |
| 14800 NE 65TH STREET, VANCOUVER WA 98662 | |
| TITLE | PACKET A5 |
| D | DRAWING NUMBER |
| SCALE: | SHEET 1 of 4 |

THIS DRAWING IS CONFIDENTIAL PROPERTY OF SUNMODO AND ITS CONTENTS MAY NOT BE DISCLOSED WITHOUT THE PRIOR WRITTEN CONSENT OF SUNMODO CORP.

NOTES:

- 1. DIMENSIONS LABELED AS MAX ARE MAXIMUM ALLOWABLE AND MAY RESULT IN END POSTS BEING OUTSIDE ARRAY EDGES. MAXIMUM DIMENSIONS MAY BE REDUCED IF DESIRED.
- 2. SEE NOTE 7 OF COVER PAGE FOR PANEL SIZES.

RAIL SPACING

LANDSCAPE: PER PANEL MANUFACTURER
 PORTRAIT: PANEL WIDTH + 0.25"

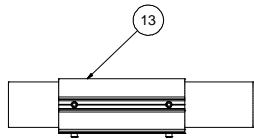

DETAIL G

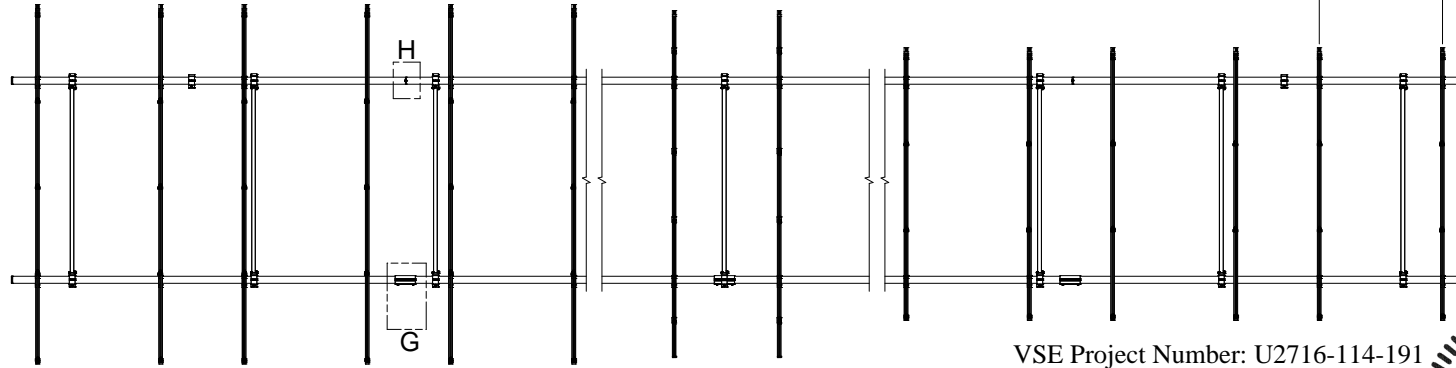

Vector Structural Engineering requires that we review each site-specific install, and we are not liable for installs at site-specific locations we have not reviewed. This document does not address site-specific installations.

VSE Project Number: U2716-114-191

STRUCTURAL ONLY



651 W. GALENA PARK BLVD. STE. 101 DRAPER, UTAH 84020
 PHONE (801) 990-1775 WWW.VECTORSE.COM

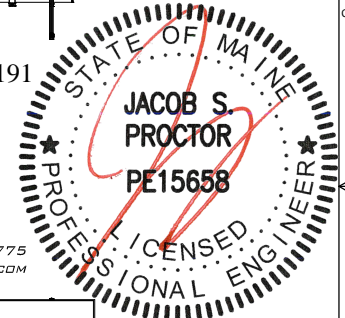

02/21/2024

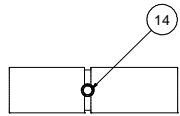

DETAIL H (ALTERNATE)

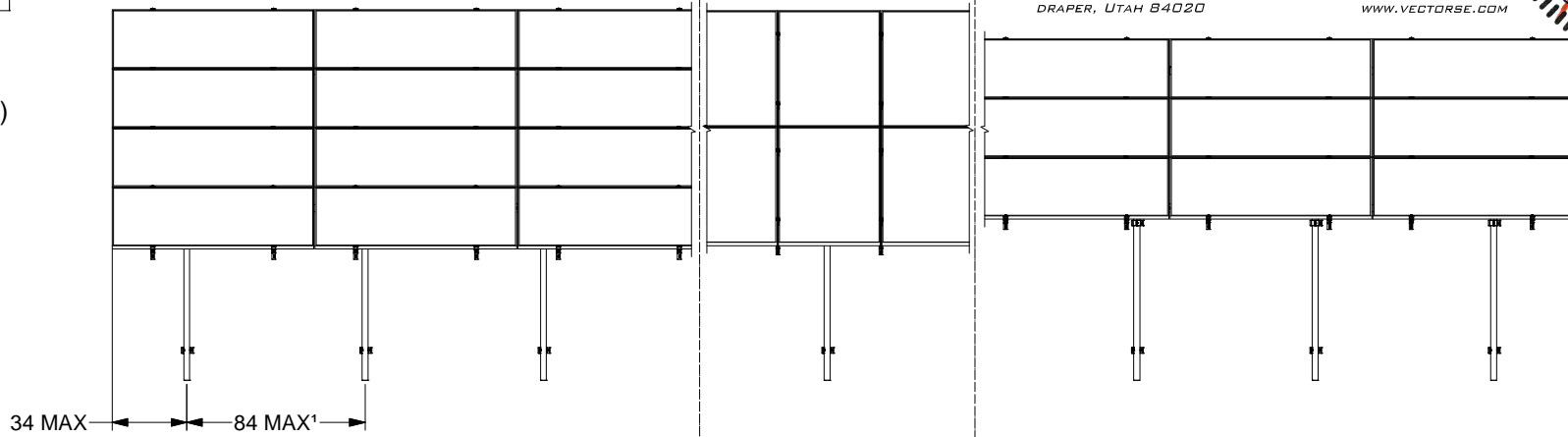

4L
4-IN-LANDSCAPE

2P
2-IN-PROTRAIT

3L
3-IN-LANDSCAPE

| | |
|----------------------|------------------|
| SunModo Corp. | |
| TITLE | PACKET AS |
| D | DRAWING NUMBER |
| SCALE: | SHEET 2 of 4 REV |

| DIMENSIONS - STANDARD PANEL | | | | DIMENSIONS - OVERSIZE PANEL | | | |
|-----------------------------|-----|-----|-----|-----------------------------|-----|-----|-----|
| ITEM | 4L | 2P | 3L | ITEM | 4L | 2P | 3L |
| A | 172 | 166 | 130 | A | 184 | 172 | 140 |
| B | 37 | 34 | 16 | B | 42 | 36 | 20 |
| C | 55 | 53 | 43 | C | 58 | 54 | 45 |
| D | 111 | 109 | 99 | D | 115 | 112 | 103 |

- NOTES**
1. DIMENSIONS IN TABLE ARE SHOWN AT MAXIMUM TILT & LEADING EDGE HEIGHT. PROJECTS WITH LOWER TILTS & LEADING EDGE HEIGHTS WILL RESULT IN REDUCED DIMENSIONS.
 2. MAX DENOTES MAXIMUM PERMISSIBLE DIMENSIONS.
 3. SEE NOTE 7 OF COVER PAGE FOR PANEL SIZES.

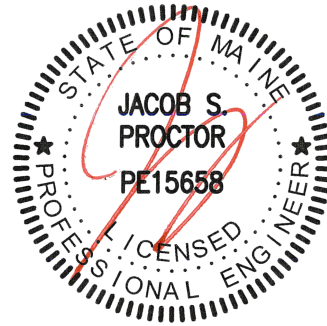

02/21/2024

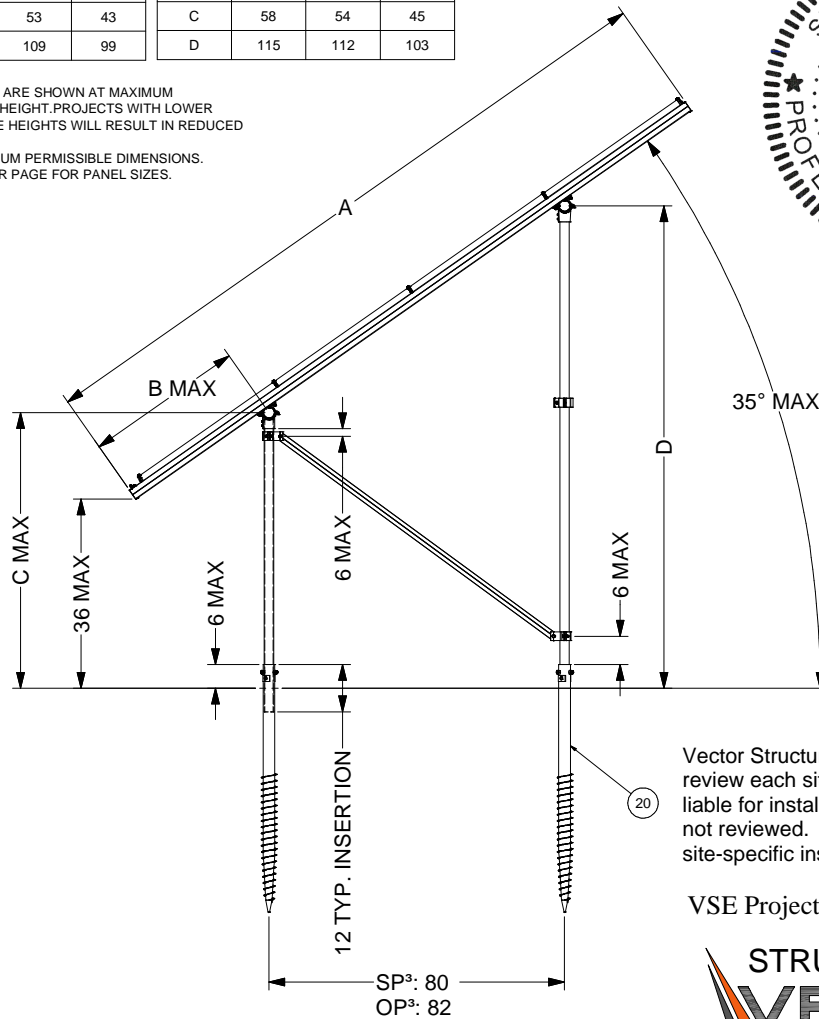

GROUND SCREW GROUND MOUNT (GSM)

Vector Structural Engineering requires that we review each site-specific install, and we are not liable for installs at site-specific locations we have not reviewed. This document does not address site-specific installations.

VSE Project Number: U2716-114-191



651 W. GALENA PARK BLVD. STE. 101 DRAPER, UTAH 84020 PHONE (801) 990-1775 WWW.VECTORSE.COM

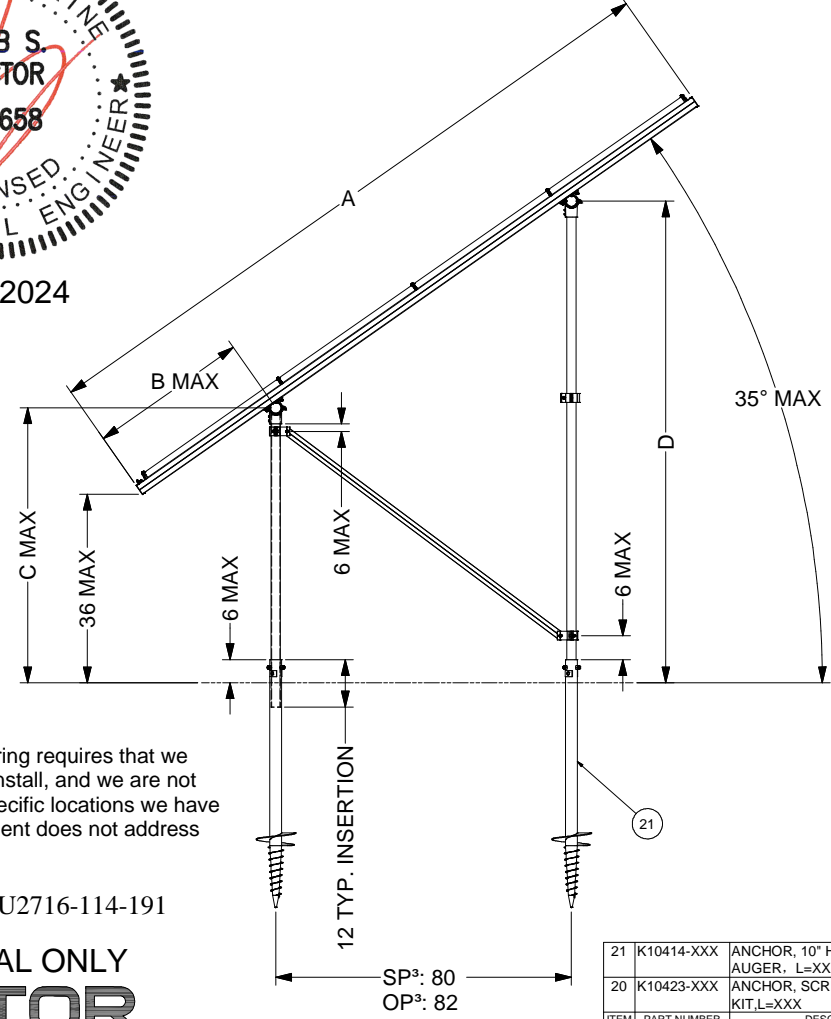

AUGER GROUND MOUNT (AGM)

| ITEM | PART NUMBER | DESCRIPTION | QTY |
|-------------------------|-------------|--------------------------------------|-----|
| 21 | K10414-XXX | ANCHOR, 10" HELIX SCREW AUGER, L=XXX | |
| 20 | K10423-XXX | ANCHOR, SCREW AUGER KIT, L=XXX | |
| SunModo Corp. | | | |
| TITLE: PACKET AS | | | |
| D DRAWING NUMBER | | | |
| SCALE: SHEET 3 of 4 REV | | | |

| DIMENSIONS - STANDARD PANEL | | | | DIMENSIONS - OVERSIZE PANEL | | | |
|-----------------------------|-----|-----|-----|-----------------------------|-----|-----|-----|
| ITEM | 4L | 2P | 3L | ITEM | 4L | 2P | 3L |
| A | 172 | 166 | 130 | A | 184 | 172 | 140 |
| B | 37 | 34 | 16 | B | 42 | 36 | 20 |
| C | 55 | 53 | 43 | C | 58 | 54 | 45 |
| D | 111 | 109 | 99 | D | 115 | 112 | 103 |

- NOTES**
1. DIMENSIONS IN TABLE ARE SHOWN AT MAXIMUM TILT & LEADING EDGE HEIGHT. PROJECTS WITH LOWER TILTS & LEADING EDGE HEIGHTS WILL RESULT IN REDUCED DIMENSIONS.
 2. MAX DENOTES MAXIMUM PERMISSIBLE DIMENSIONS.
 3. SEE NOTE 7 OF COVER PAGE FOR PANEL SIZES.
 4. K10268-005 (2" PIPE BASE KIT) OR K10302-001 (2" PIPE BASE KIT)

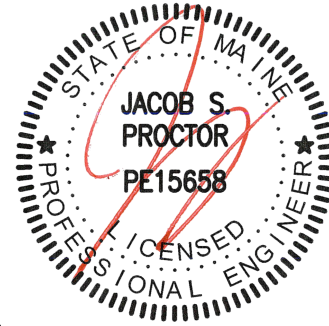

02/21/2024

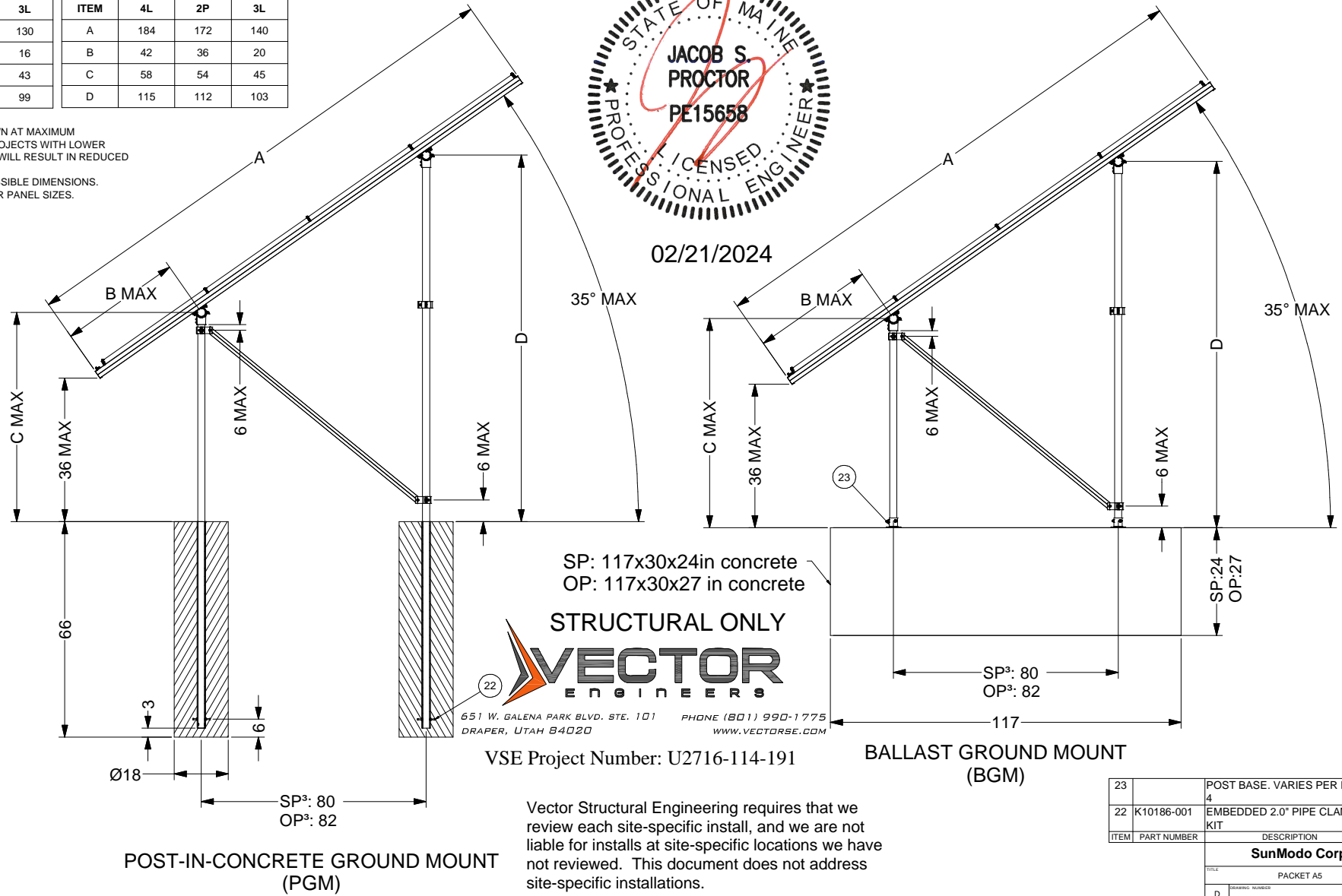

VSE Project Number: U2716-114-191

Vector Structural Engineering requires that we review each site-specific install, and we are not liable for installs at site-specific locations we have not reviewed. This document does not address site-specific installations.

| 23 | | POST BASE. VARIES PER NOTE | |
|----------------------|-------------|------------------------------|-----|
| 4 | | | |
| 22 | K10186-001 | EMBEDDED 2.0" PIPE CLAMP KIT | |
| ITEM | PART NUMBER | DESCRIPTION | QTY |
| SunModo Corp. | | | |
| TITLE | | | |
| PACKET AS | | | |
| D | | | |
| DRAWING NUMBER | | | |
| SCALE: | | SHEET 4 of 4 | REV |