

Packet D6	
Model Code	ASCE 7-22
Exposure Category	C
Wind Speed	150 mph and Lower
Ground Snow Load	0 PSF
Tilt	10 TO 20 DEG

- NOTES: UNLESS OTHERWISE SPECIFIED**
- THIS DRAWING IS NOT FOR CONSTRUCTION UNTIL ENGINEERING HAS REVIEWED AND STAMPED THIS DOCUMENT.
  - DIMENSIONS SHOWN ARE INCHES.
  - THE SELF-BONDING SYSTEM AND SINGLE GROUND LUG IS FOR USE WITH PV MODULES THAT HAVE A MAXIMUM SERIES FUSE RATING OF 30A.
  - MATERIALS ARE AS SPECIFIED OR EQUIVALENT:  
HARDWARE: 304 STAINLESS STEEL  
FABRICATED EXTRUDED PARTS: 6005-T5 ALUMINUM ALLOY  
FABRICATED DIE CAST PARTS: ANSI/AA A380 ALUMINUM ALLOY  
STEEL PIPE: SCHEDULE 40 GALVANIZED  
ALUMINUM PIPE: SCHEDULE 10 ANODIZED
  - THE MAXIMUM PERMISSIBLE LENGTH OF ANY STRUCTURE SHALL BE 200 FT. FOR SYSTEMS USING A SHARED RAIL CONFIGURATION, A THERMAL BREAK IS REQUIRED IN THE RAIL EVERY 40 FT. PER THE DRAWING DETAILS.
  - SUNTURF SYSTEM CONFIGURATIONS:  
PANEL ARRANGEMENT: 4LXN, 3LXN, OR 2PXN.  
TILT ANGLE: UP TO 20DEG.  
FOUNDATION TYPE: GSM, AGM, BGM, OR PGM.
  - PANEL DIMENSIONS ARE AS FOLLOWS:  
STANDARD PANEL (SP): MAX AREA: 3444 in<sup>2</sup>  
LARGE FORMAT (LF): MAX AREA: 3825 in<sup>2</sup>  
PANEL FRAME HEIGHTS: 30mm TO 50mm.
  - FOUNDATION TYPES:  
GSM = GROUND SCREW GROUND MOUNT  
AGM = HELICAL AUGER GROUND MOUNT  
PGM = POST-IN-CONCRETE GROUND MOUNT  
BSM = BALLAST GROUND MOUNT
  - SEE LETTER PROVIDED BY VECTOR STRUCTURAL ENGINEERING, LLC FOR FOUNDATION DESIGN AND LOAD TESTING REQUIREMENTS.

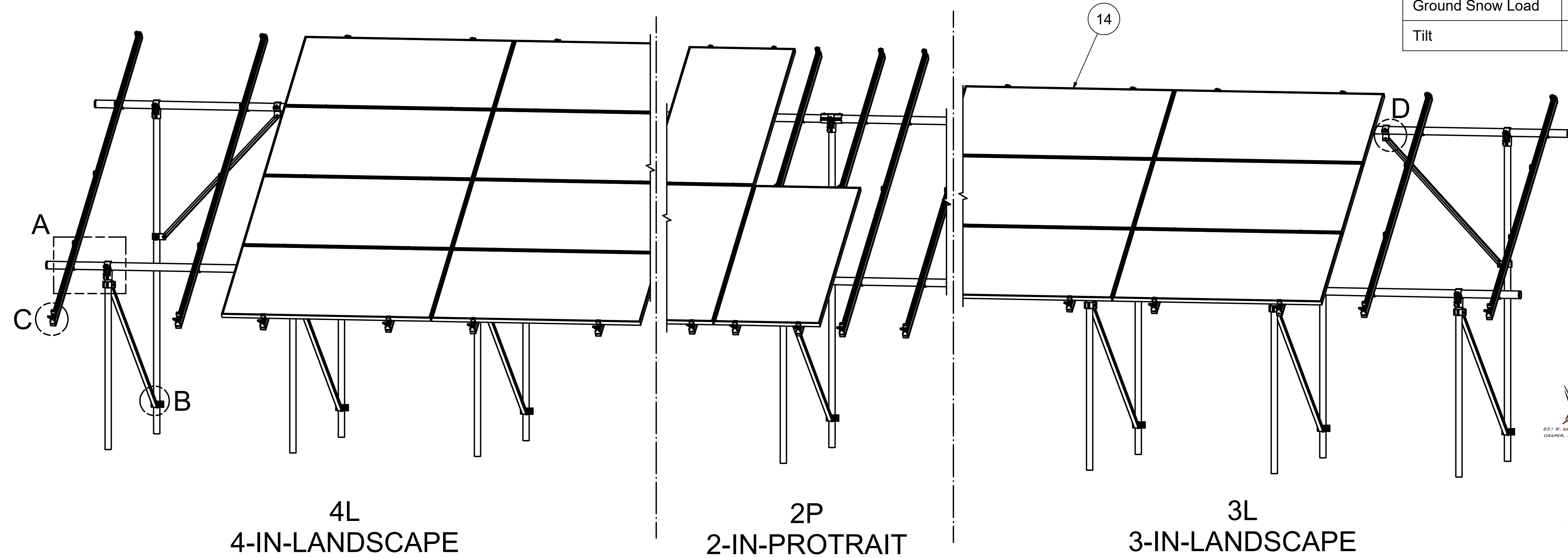

**VECTOR ENGINEERS**  
651 W. GALENA PARK BLVD. STE. 101 PHOENIX, AZ 85013  
ORANGE, UTAH 84050

**JACOB S. PROCTOR**  
LICENSE No. 74277  
STATE OF FLORIDA  
PROFESSIONAL ENGINEER

05/20/2024  
Jacob S. Proctor  
No. 74277  
VSE Project Number: U2716.0388.241

Vector Structural Engineering requires that we review each site-specific install, and we are not liable for installs at site-specific locations we have not reviewed. This document does not address site-specific installations.

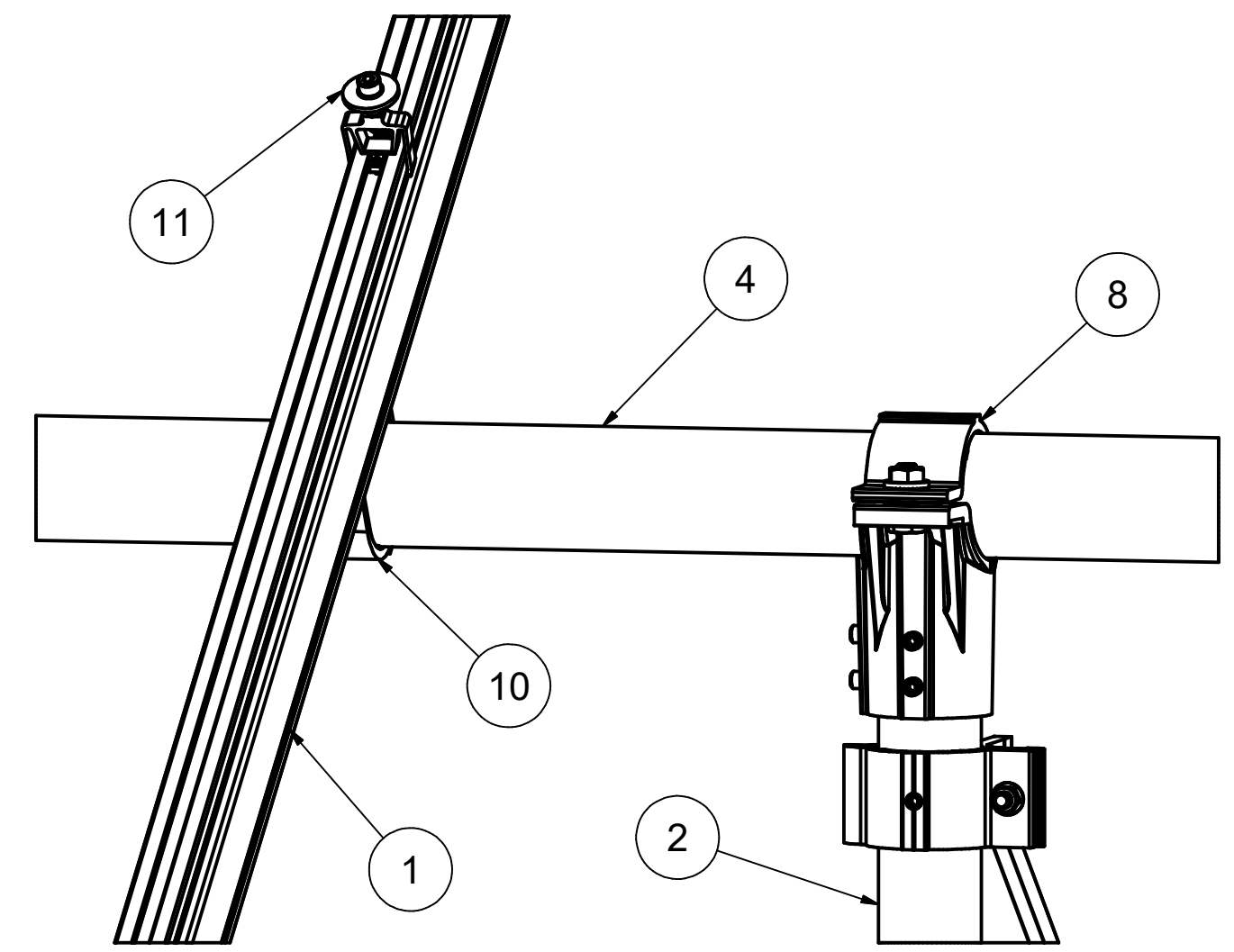

DETAIL A

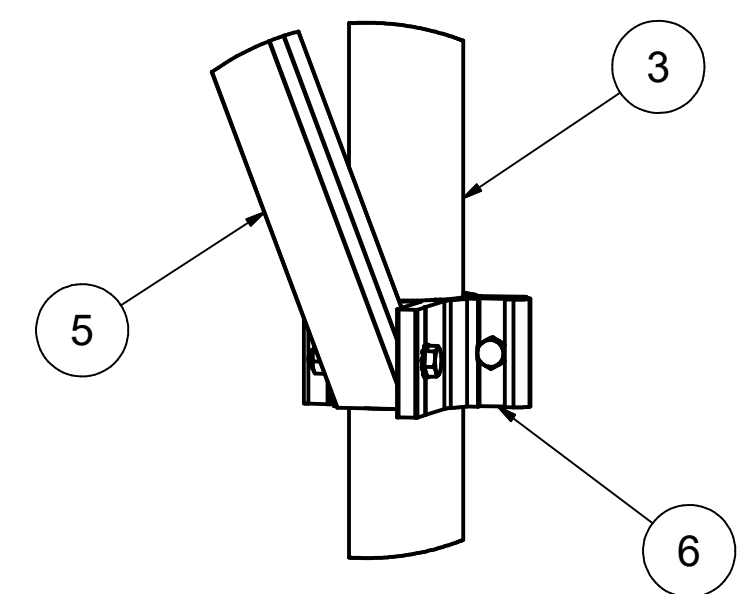

DETAIL B

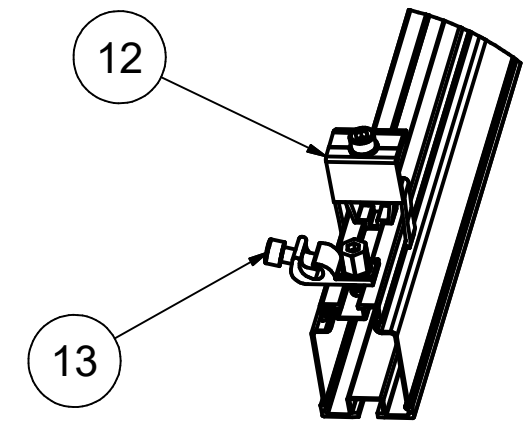

DETAIL C

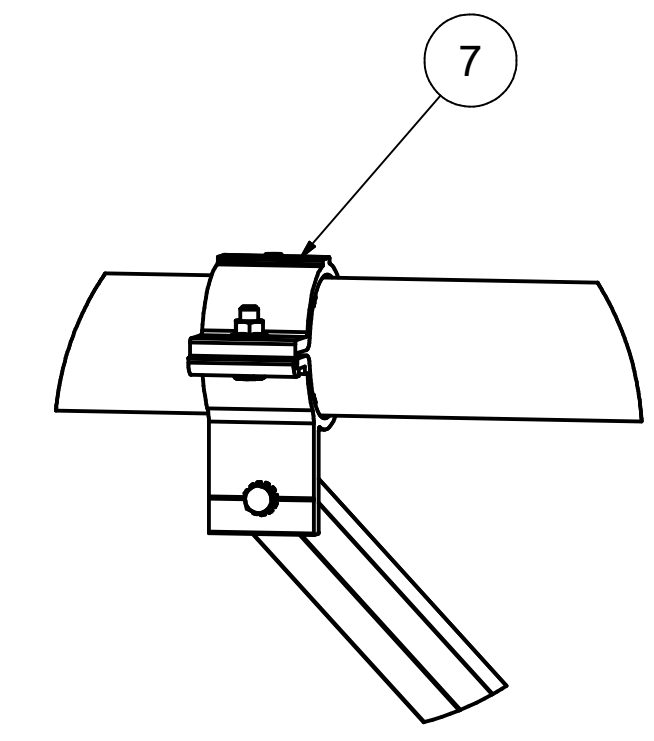

DETAIL D

ITEM	PART NUMBER	DESCRIPTION	QTY
14		PANEL	
13	K10469-004	SMR GROUND LUG KIT	
12	K10418-XXX	SMR POP-ON END CLAMP KIT,CLEAR	
11	K10417-XXX	MID CLAMP,SMR POP-ON,CLEAR	
10	K10343-005	2.5" AL PIPE U-CLAMP KIT	
9	K10342-001	2.5" PIPE SPLICE KIT	
8	K10341-002	2.5" PIPE TEE KIT	
7	K10222-001	2.5" PIPE CLAMP KIT	
6	K10219-001	2" AL PIPE CLAMP KIT	
5	A50164-XXX	1.5" SQ. STL TUBE BRACE, L=XXX	
4	A21168-XXX	PIPE, HSS, 2.875" OD X 12 GAUGE,L=XXX	
3	A21165-XXX (REAR)	PIPE, HSS, 2.375" OD X 12 GAUGE,L=XXX	
2	A21165-XXX (FRONT)	PIPE, HSS, 2.375" OD X 12 GAUGE,L=XXX	
1	A20444-XXX	SMR300 RAIL, L=XXX	

**SunModo Corp.**  
14800 NE 65TH STREET, VANCOUVER WA 98682

TITLE: PACKET D6  
DRAWING NUMBER: D

DATE: 05/20/2024  
DRAWN BY: PHQ  
CHECKED BY:

APPROVALS:

THIS DRAWING IS CONFIDENTIAL PROPERTY OF SUNMODO AND ITS CONTENTS MAY NOT BE DISCLOSED WITHOUT THE PRIOR WRITTEN CONSENT OF SUNMODO CORP.

**NOTES: UNLESS OTHERWISE SPECIFIED**

1. APPROVED RAIL PROFILES - STANDARD PANELS  
A20288-XXX (HR300 RAIL), A20297-001 (END CAP),  
K10343-002 (U-CLAMP KIT);  
A20145-XXX (HR350 RAIL), A20285-001 (END CAP),  
K10343-001 (U-CLAMP KIT).
2. APPROVED RAIL PROFILES - OVERSIZE PANELS  
\* A20288-XXX (HR300 RAIL), A20297-001 (END CAP),  
K10343-002 (U-CLAMP KIT);  
\* A20145-XXX (HR350 RAIL), A20285-001 (END CAP),  
K10343-001 (U-CLAMP KIT).
3. K10224-XXX END CLAMP KIT OR K10299-XXX ADJ.  
END CLAMP KIT.

**ALTERNATE(ALT) DETAILS**  
**HR300, HR350 RAIL PROFILES**

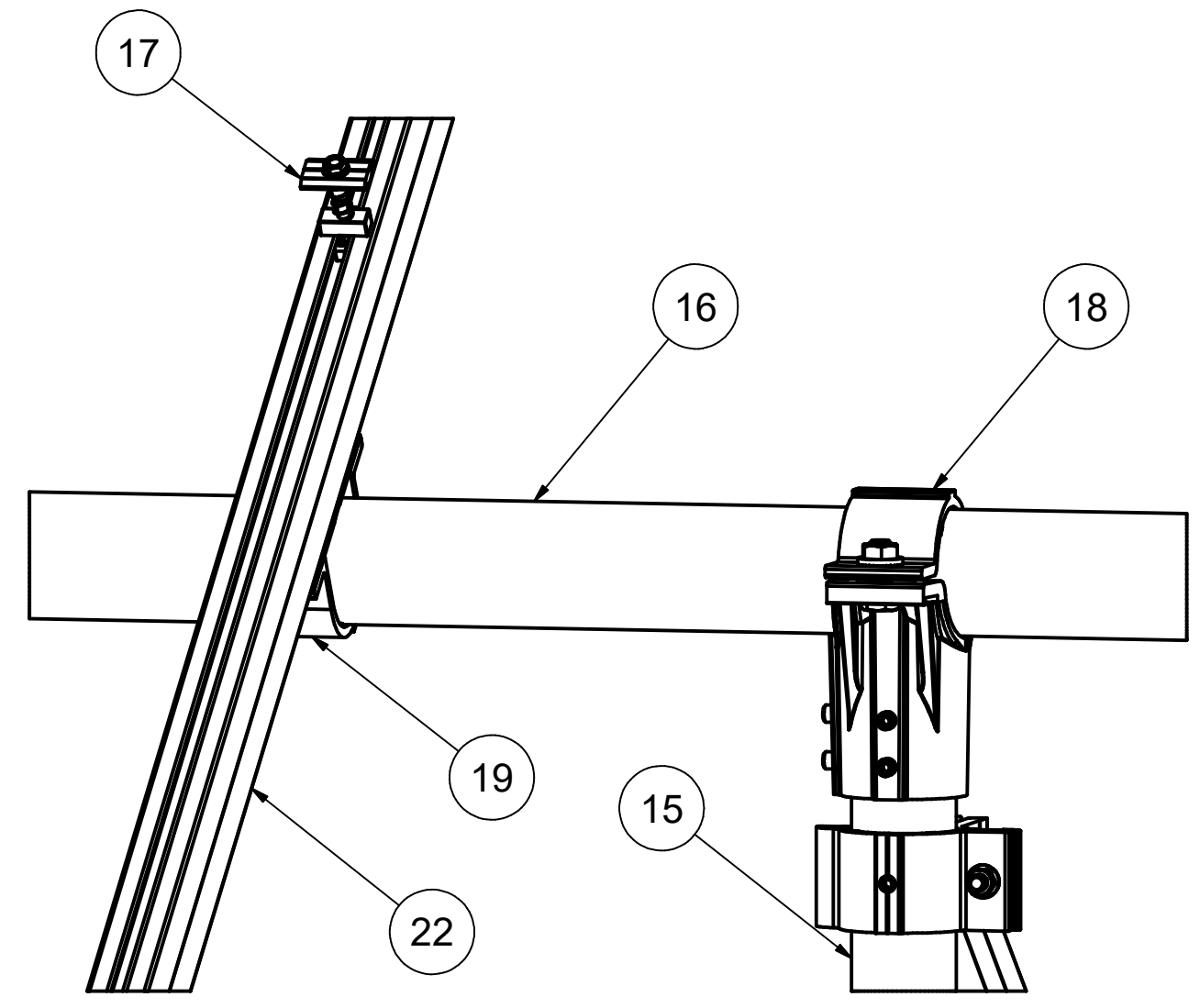

DETAIL A-ALT

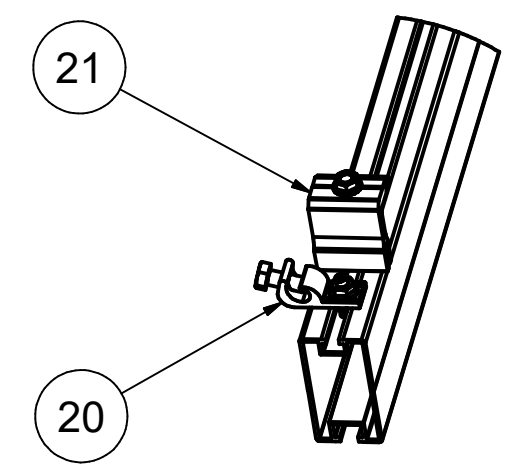

DETAIL C-ALT

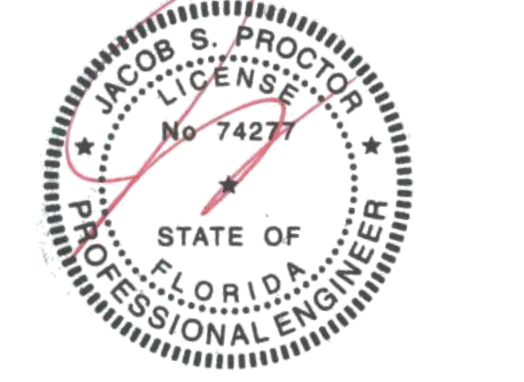

05/20/2024  
Jacob S. Proctor  
No. 74277

VSE Project Number: U2716.0388.241

Vector Structural Engineering requires that we review each site-specific install, and we are not liable for installs at site-specific locations we have not reviewed. This document does not address site-specific installations.

22		HELIO RAIL. VARIES PER NOTE 1 & 2	
21		END CLAMP KIT. VARIES PER NOTE 3	
20	K10469-003	HR GROUNDING LUG KIT	
19	K10343-XXX	2.5" AL PIPE U-CLAMP KIT	
18	K10341-002	2.5" PIPE TEE KIT	
17	K10180-001	GROUNDING MID-CLAMP KIT WITH T COLLAR BOLT AND GROUNDING BASE	
16	A21168-XXX	PIPE, HSS, 2.875" OD X 12 GAUGE, L=XXX	
15	A21165-XXX	PIPE, HSS, 2.375" OD X 12 GAUGE, L=XXX	
ITEM	PART NUMBER	DESCRIPTION	QTY

**SunModo Corp.**

TITLE: PACKET D6

DRAWING NUMBER: D

SCALE: SHEET 2 of 5 REV

**NOTES:**  
 1. DIMENSIONS LABELED AS MAX ARE MAXIMUM ALLOWABLE AND MAY RESULT IN END POSTS BEING OUTSIDE ARRAY EDGES. MAXIMUM DIMENSIONS MAY BE REDUCED IF DESIRED.  
 2. SEE NOTE 7 OF COVER PAGE FOR PANEL SIZES.

**RAIL SPACING**  
 LANDSCAPE: PER PANEL MANUFACTURER  
 PORTRAIT: PANEL WIDTH + 0.25"

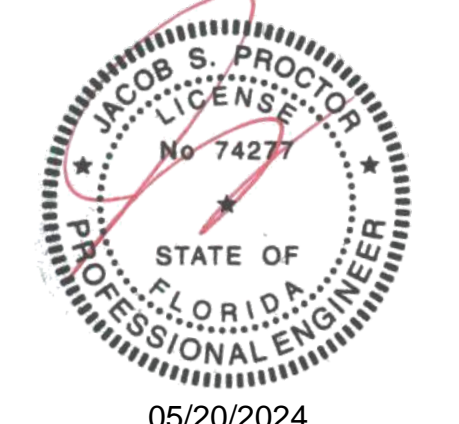
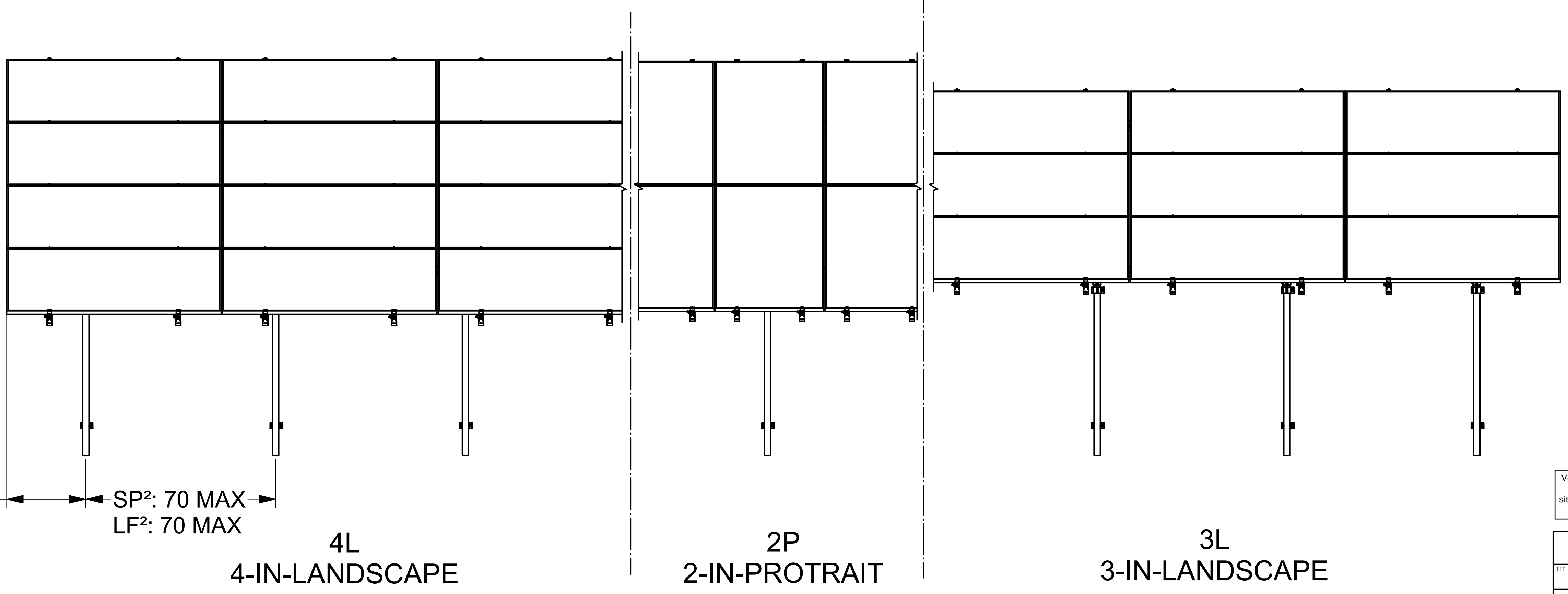
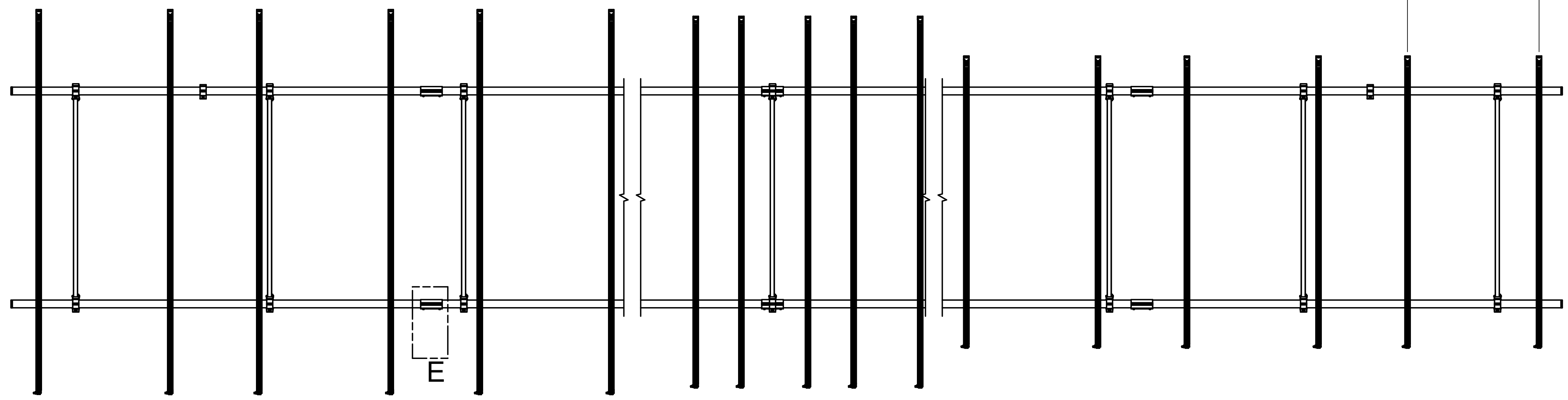
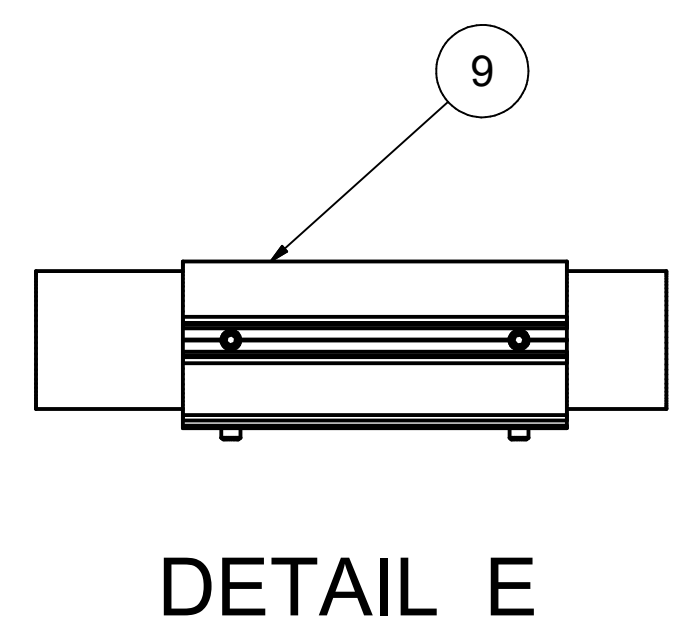

05/20/2024  
 Jacob S. Proctor  
 No. 74277  
 VSE Project Number: U2716.0388.241

Vector Structural Engineering requires that we review each site-specific install, and we are not liable for installs at site-specific locations we have not reviewed. This document does not address site-specific installations.

<b>SunModo Corp.</b>	
TITLE	PACKET D6
D	DRAWING NUMBER
SCALE:	SHEET 3 of 5 REV

DIMENSIONS - STANDARD PANEL			
ITEM	4L	2P	3L
A	168	164	130
B	40	40	15
C	47	47	39
D	82	82	64

DIMENSIONS - LARGE FORMAT PANEL			
ITEM	4L	2P	3L
A	172	170	140
B	40	40	20
C	47	47	40
D	82	82	66

**NOTES**

1. DIMENSIONS IN TABLE ARE SHOWN AT MAXIMUM TILT & LEADING EDGE HEIGHT. PROJECTS WITH LOWER TILTS & LEADING EDGE HEIGHTS WILL RESULT IN REDUCED DIMENSIONS.
2. MAX DENOTES MAXIMUM PERMISSIBLE DIMENSIONS.
3. SEE NOTE 7 OF COVER PAGE FOR PANEL SIZES.
4. SEE LETTER PROVIDED BY VECTOR STRUCTURAL ENGINEERING, LLC FOR REQUIRED LOAD TESTING, FOUNDATION AND ANCHORAGE REQUIREMENTS, AND OTHER INFORMATION NOT SHOWN.
5. SP DENOTES STANDARD MODULE & LF DENOTES LARGE FORMAT MODULES.

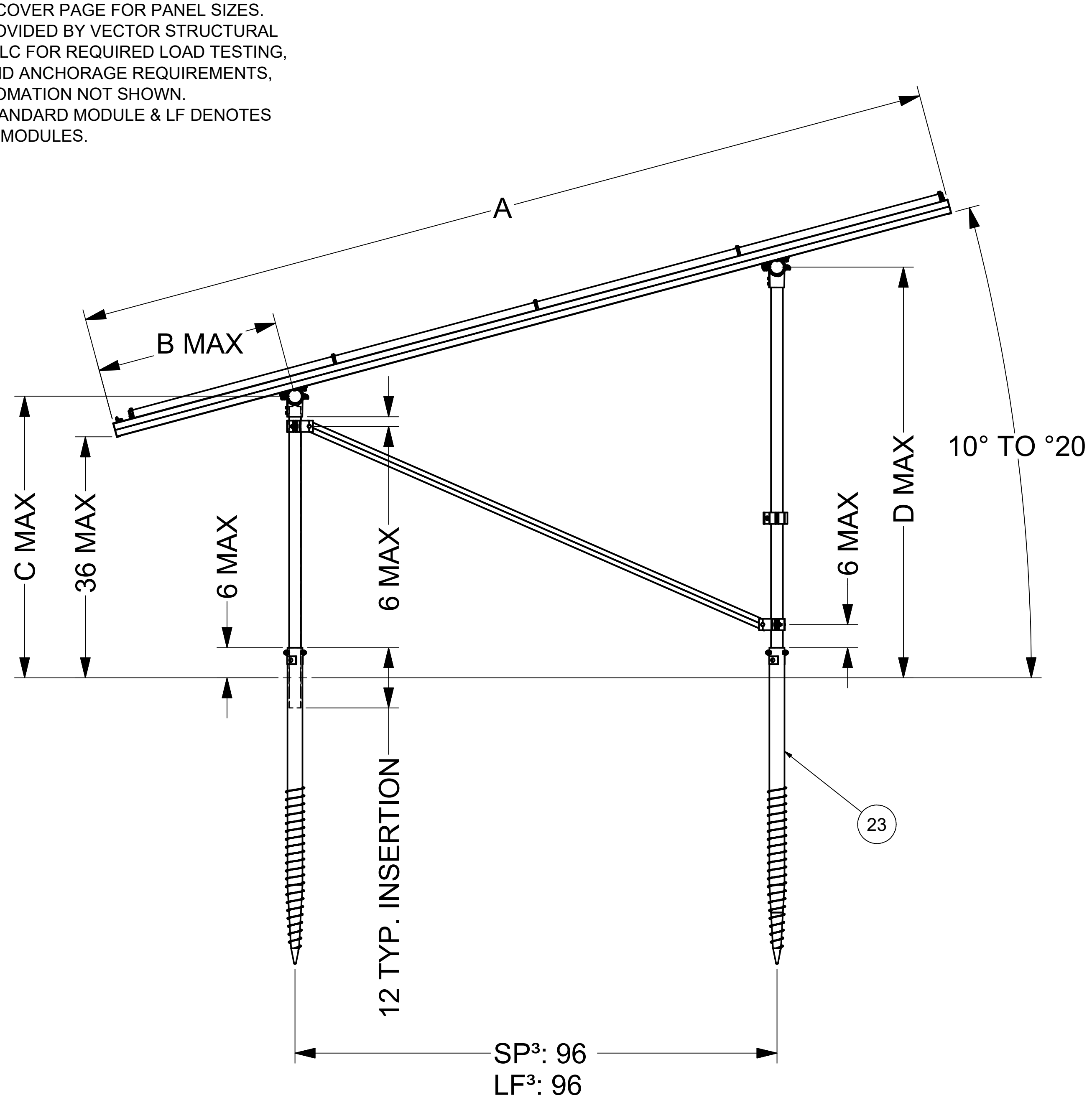

**GROUND SCREW GROUND MOUNT (GSM)<sup>4</sup>**

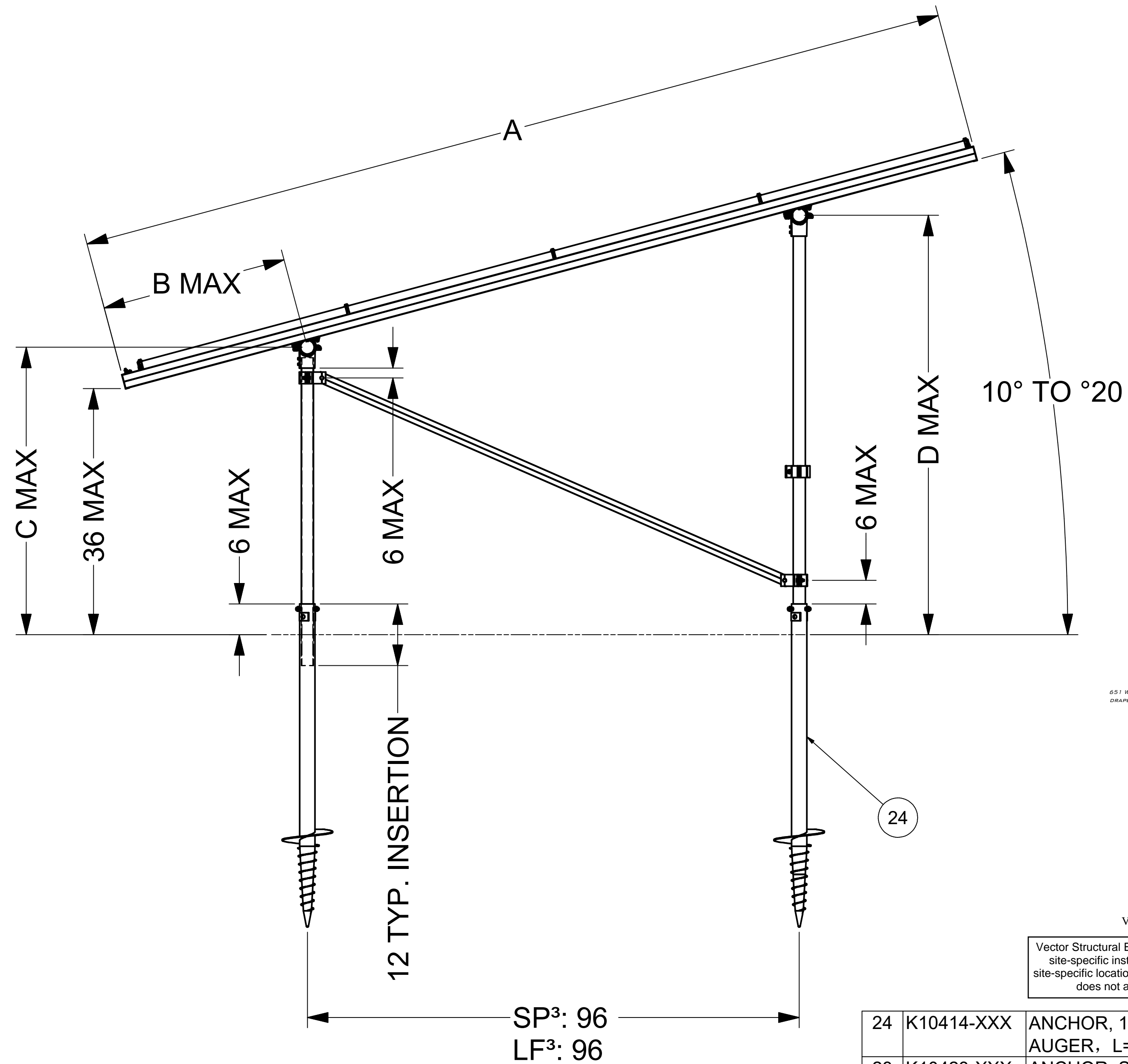

**AUGER GROUND MOUNT (AGM)<sup>4</sup>**

ITEM	PART NUMBER	DESCRIPTION	QTY
24	K10414-XXX	ANCHOR, 10" HELIX SCREW AUGER, L=XXX	
23	K10423-XXX	ANCHOR, SCREW AUGER KIT, L=XXX	

Vector Structural Engineering requires that we review each site-specific install, and we are not liable for installs at site-specific locations we have not reviewed. This document does not address site-specific installations.

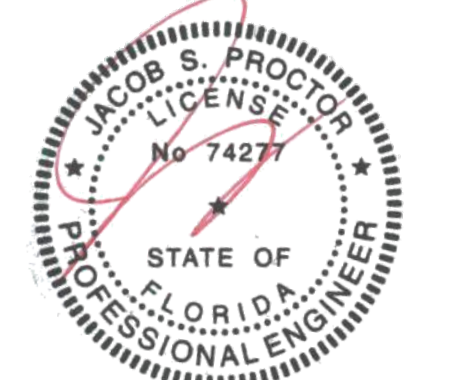

05/20/2024  
Jacob S. Proctor  
No. 74277  
VSE Project Number: U2716.0388.241

<b>SunModo Corp.</b>	
TITLE	PACKET D6
D	DRAWING NUMBER
SCALE:	SHEET 4 of 5 REV

DIMENSIONS - STANDARD PANEL			
ITEM	4L	2P	3L
A	168	164	130
B	40	40	15
C	47	47	39
D	82	82	64

DIMENSIONS - LARGE FORMAT PANEL			
ITEM	4L	2P	3L
A	172	170	140
B	40	40	20
C	47	47	40
D	82	82	66

**NOTES**

1. DIMENSIONS IN TABLE ARE SHOWN AT MAXIMUM TILT & LEADING EDGE HEIGHT. PROJECTS WITH LOWER TILTS & LEADING EDGE HEIGHTS WILL RESULT IN REDUCED DIMENSIONS.
2. MAX DENOTES MAXIMUM PERMISSIBLE DIMENSIONS.
3. SEE NOTE 7 OF COVER PAGE FOR PANEL SIZES.
4. K10268-005 (2" PIPE BASE KIT) OR K10302-001 (2" PIPE BASE KIT)
5. SEE LETTER PROVIDED BY VECTOR STRUCTURAL ENGINEERING, LLC FOR REQUIRED LOAD TESTING, FOUNDATION AND ANCHORAGE REQUIREMENTS, AND OTHER INFORMATION NOT SHOWN.
6. SP DENOTES STANDARD MODULE & LF DENOTES LARGE FORMAT MODULES.

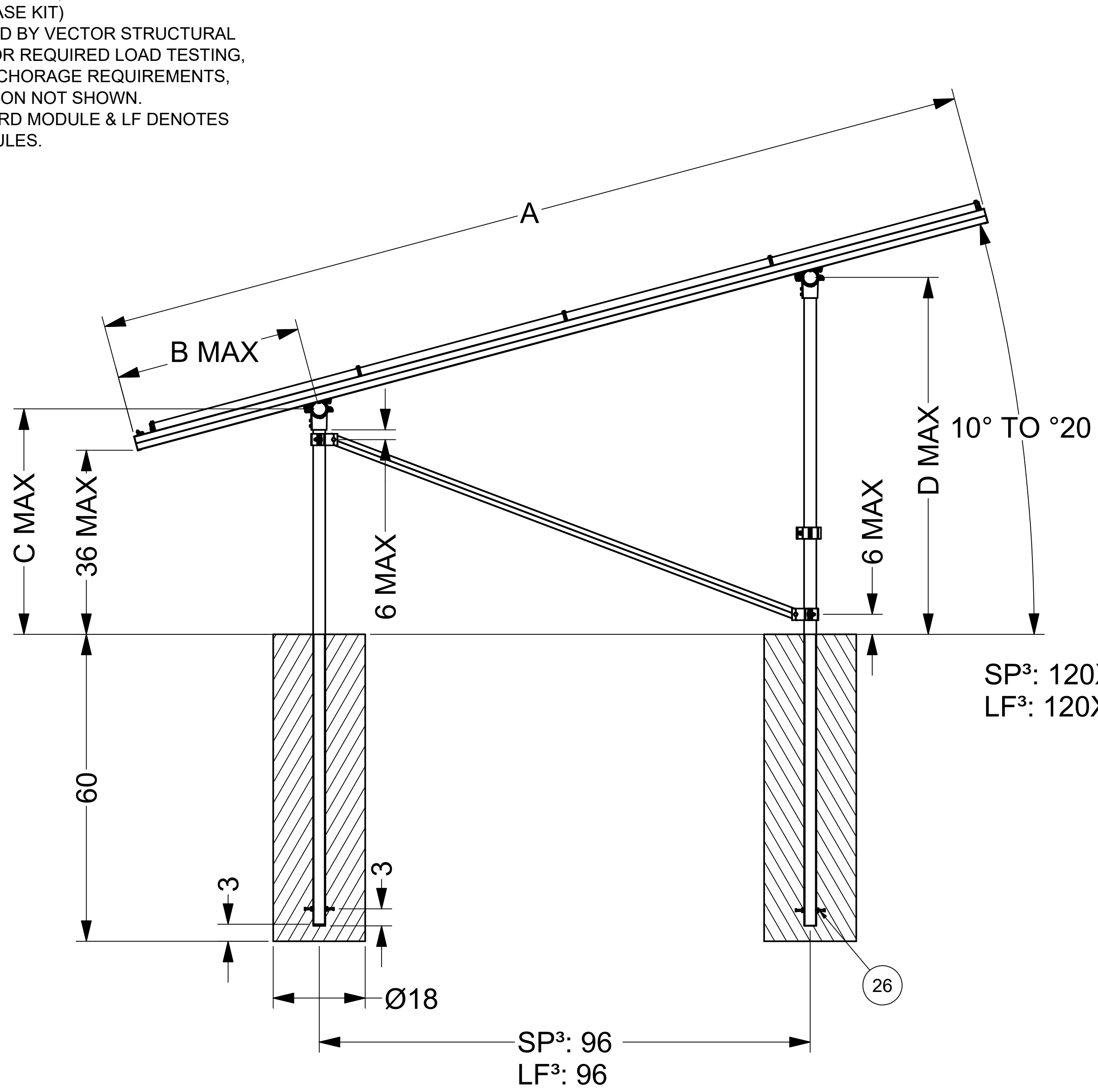

**POST-IN-CONCRETE GROUND MOUNT (PGM)<sup>5</sup>**

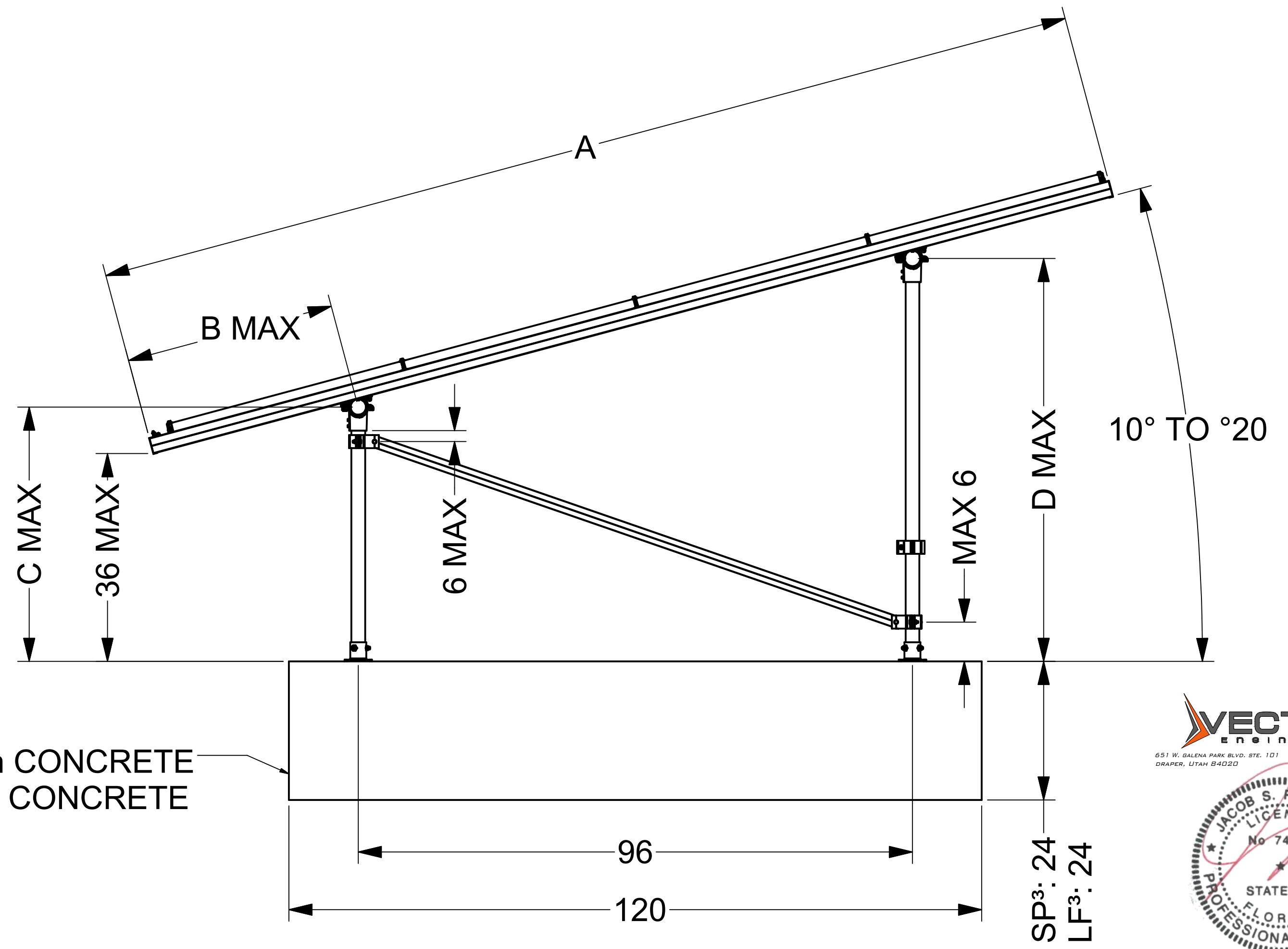

**BALLAST GROUND MOUNT (BGM)<sup>5</sup>**

SP³: 120X36X24 in CONCRETE  
LF³: 120X36X24 in CONCRETE

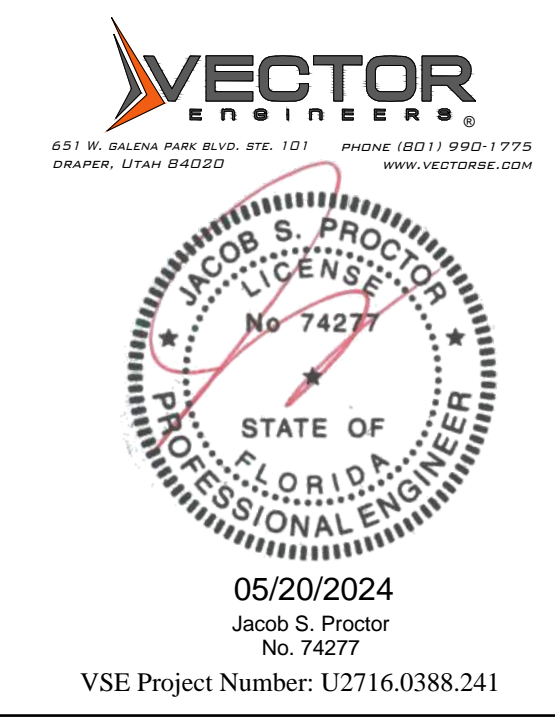

Vector Structural Engineering requires that we review each site-specific install, and we are not liable for installs at site-specific locations we have not reviewed. This document does not address site-specific installations.

25		POST BASE. VARIES PER NOTE 4	
26	K10186-001	EMBEDDED 2.0" PIPE CLAMP KIT	
ITEM	PART NUMBER	DESCRIPTION	QTY
<b>SunModo Corp.</b>			
TITLE: PACKET D6			
DRAWING NUMBER:			
SCALE: SHEET 5 of 5 REV			