



Project Number: U2716.0386.241

March 25, 2024

Sunmodo  
14800 NE 65<sup>th</sup> Street  
Vancouver, WA 98682

**REFERENCE: SunModo Sunturf Ground Mount A17 – Standard Panels  
Ground Mount PV Array Installation**

To Whom It May Concern:

Per request of SunModo, we have been asked to prepare the structural design of a ground-mounted PV solar array system with several foundation options as shown in the attached calculations. The adopted building code in this jurisdiction is the Florida Building Code, 2023 Edition (2021 IBC). Vector Structural Engineering requires that we review each site-specific install, and we are not liable for installs at site-specific locations we have not reviewed. The following design parameters are used in our analysis:

- Minimum Design Loads for Buildings and Other Structures (ASCE 7-22)
- Design wind speed for risk category I structures: 140 mph
- Wind exposure: B
- Ground snow load: 70 psf
- The ground screws and helical piers must be tested to 1.5 times uplift and 2.0 times lateral reactions found in the table below. A minimum of one ground screw or helical pier must be tested.

Load (ASD)	Value (lbs)	Factor of Safety	Test Value (lbs)
UPLIFT	2424	1.5	3636
LATERAL	1898	2	3796

Foundation concrete shall have a minimum compressive strength of 2500 psi at 28 days. Cement for all concrete shall be Type I or II with a water/cement ratio of 0.50. Maximum aggregate size shall be 3/4". No special inspection of concrete strength is required.

Footings are designed based on an allowable soil bearing pressure of 1500 psf an allowable skin friction of 250 psf, an allowable lateral bearing pressure of 150 pcf, and a coefficient of friction of 0.3. Vector Structural Engineering strongly recommends independent soils testing be performed by a licensed geotechnical engineer to verify the assumed soil parameters.

All ground mounts are to be installed per manufacturer’s recommendations. The use of solar panel support span tables provided by the manufacturer is allowed only where the site conditions and solar panel configuration match the description of the span tables. Electrical engineering is beyond our scope. All work performed must be in accordance with accepted industry-wide methods and applicable safety standards. Vector Structural Engineering assumes no responsibility for improper installation of the solar panels.

Very truly yours,

VECTOR STRUCTURAL ENGINEERING, LLC

\_\_\_\_\_  
Russell Emery, P.E.  
License: 71060 - Expires: 02/28/2025  
Project Engineer

Enclosures

RNE/mih

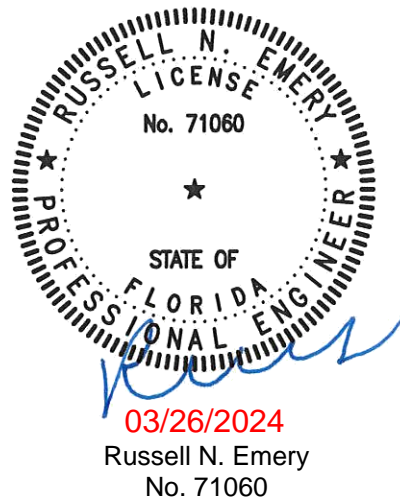



JOB NO. U2716-0386-241  
 PROJECT SUNMODO SUNTURF GROUND MOUNT A17  
 SUBJECT ALL OPTIONS

651 W GALENA PARK BLVD. #101 (801) 990-1775  
 DRAPER, UTAH 84020 (801) 990-1776 FAX

NOTES:

- SEE SUNMODO SHOP DRAWINGS FOR GROUND MOUNT MEMBER SIZES, GEOMETRY, AND POST SPACING

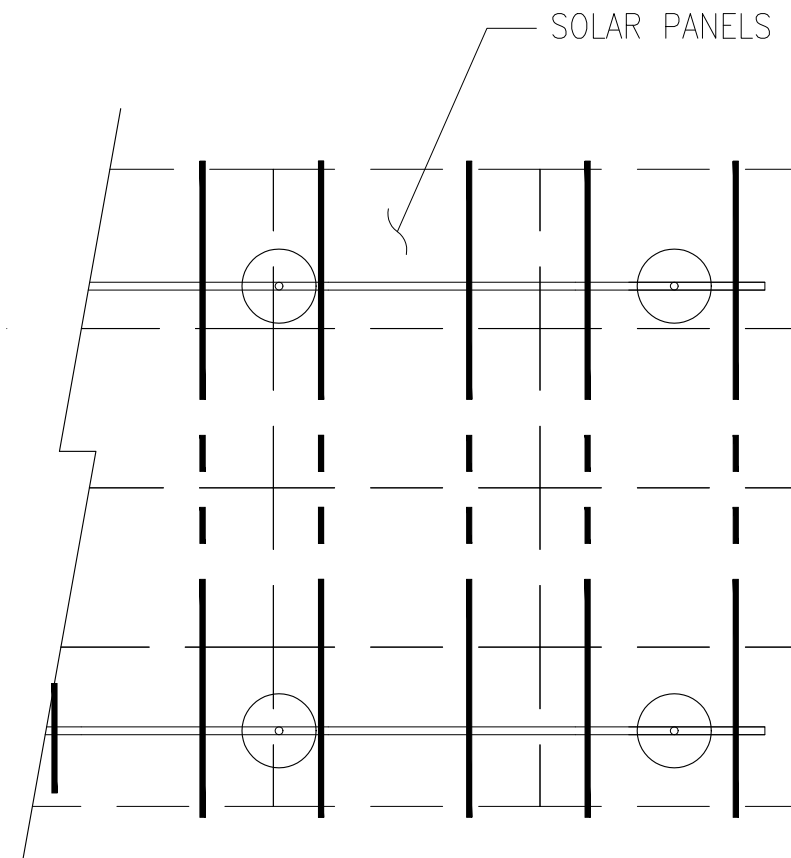
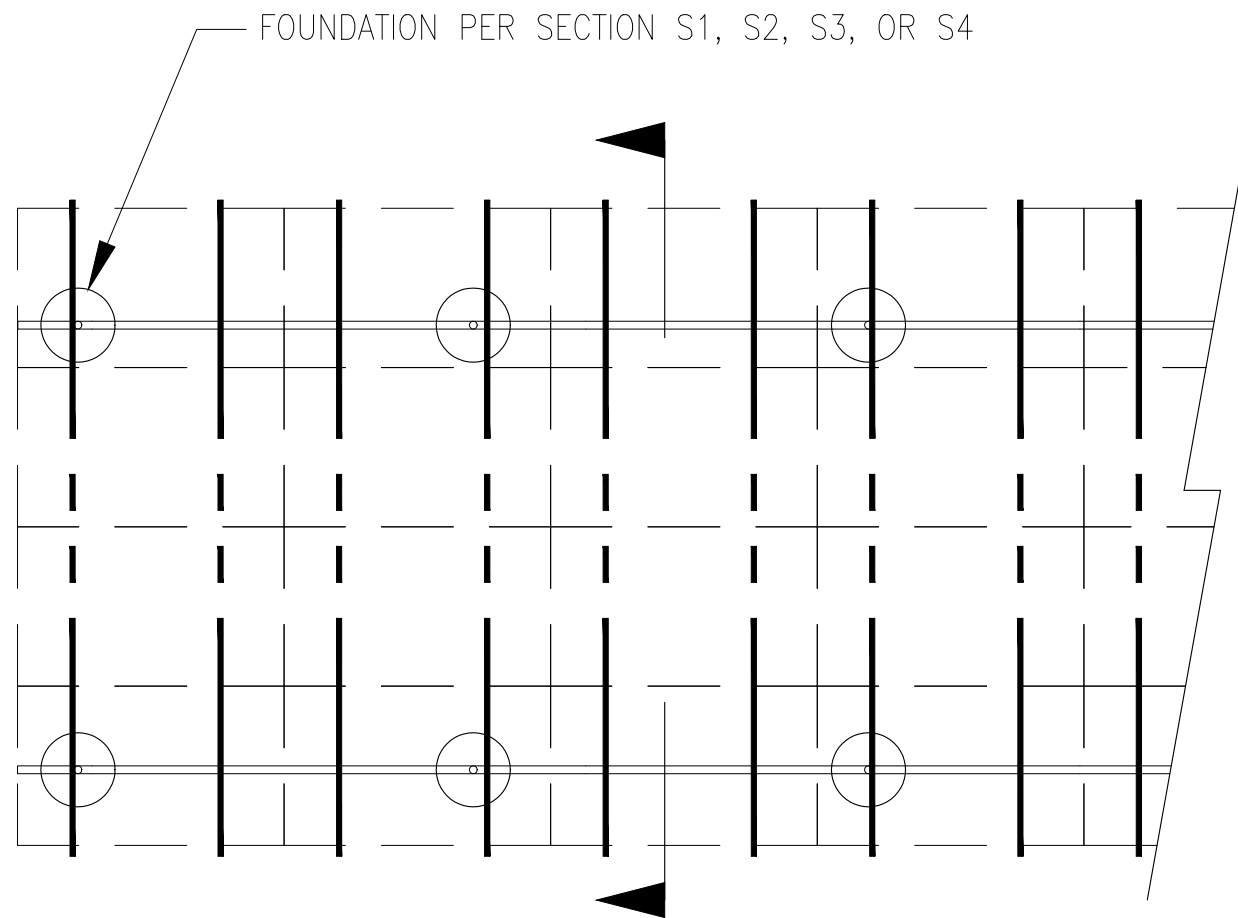

RUSSELL N. EMERY  
 LICENSE No. 71060  
 STATE OF FLORIDA  
 PROFESSIONAL ENGINEER  
 03/26/2024  
 Russell N. Emery  
 No. 71060

Vector Structural Engineering requires that we review each site-specific install, and we are not liable for installs at site-specific locations we have not reviewed. This document does not address site-specific installations.

**PV ARRAY PLAN**

N.T.S.

**P1**



JOB NO. U2716-0386-241

PROJECT SUNMODO SUNTURF GROUND MOUNT A17

SUBJECT DRILLED PIER OPTION

NOTES:

- 1. SEE SUNMODO SHOP DRAWINGS FOR GROUND MOUNT MEMBER SIZES AND GEOMETRY

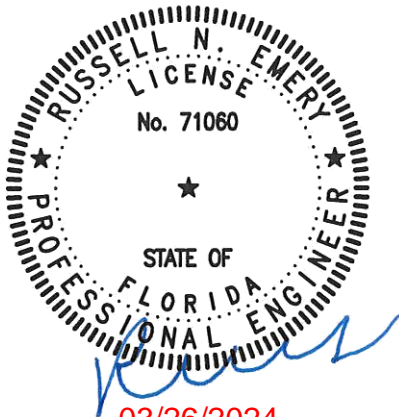

03/26/2024
Russell N. Emery
No. 71060

Vector Structural Engineering requires that we review each site-specific install, and we are not liable for installs at site-specific locations we have not reviewed. This document does not address site-specific installations.

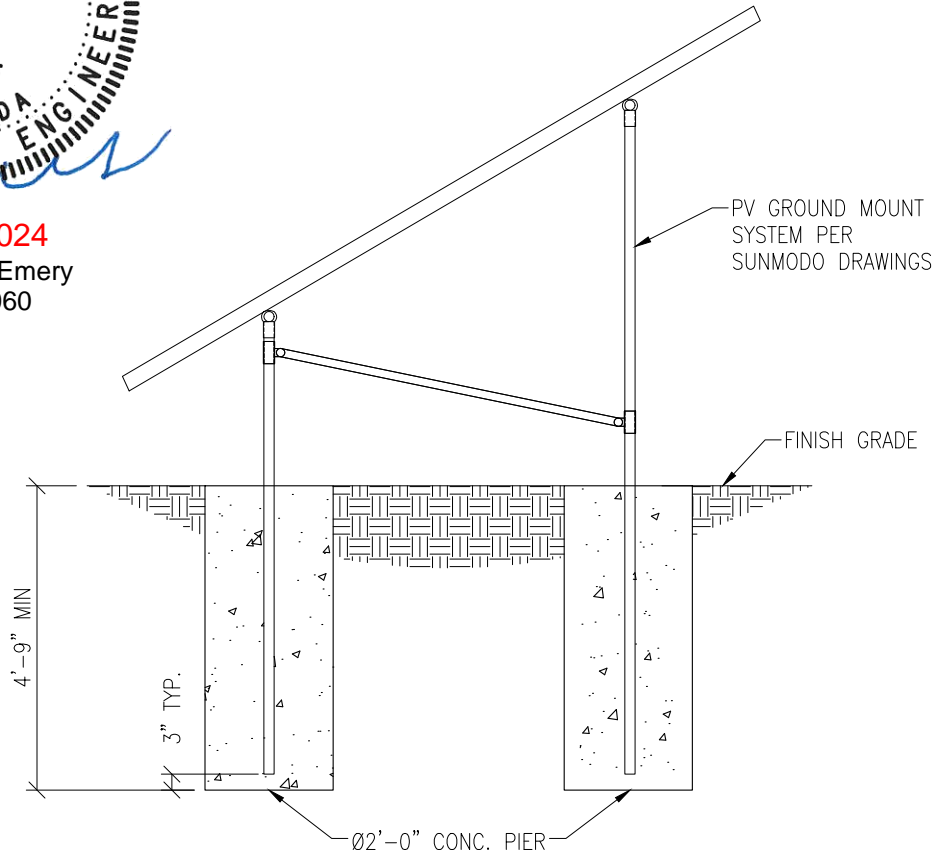

DRILLED PIER SECTION

N.T.S.





JOB NO. U2716-0386-241

PROJECT SUNMODO SUNTURF GROUND MOUNT A17

SUBJECT HELICAL PIER OPTION

NOTES:

- 1. SEE SUNMODOD SHOP DRAWINGS FOR GROUND MOUNT MEMBER SIZES AND GEOMETRY
- 2. A MINIMUM OF (1) HELICAL PIER SHALL BE LOAD TESTED PER THE TEST LOADS LISTED ON THE COVER PAGE OF THIS LETTER. FAILURE CRITERIA IS AS FOLLOWS:
  - 2.1. LATERAL DEFLECTION OF 1" MEASURED AT GRADE UNDER LATERAL LOAD
  - 2.2. VERTICAL DEFLECTION OF 1/2" UNDER AXIAL LOAD
- 3. LOAD TESTS SHALL BE PERFORMED BY A LICENSED CONTRACTOR AS APPROVED BY THE AHJ

Vector Structural Engineering requires that we review each site-specific install, and we are not liable for installs at site-specific locations we have not reviewed. This document does not address site-specific installations.

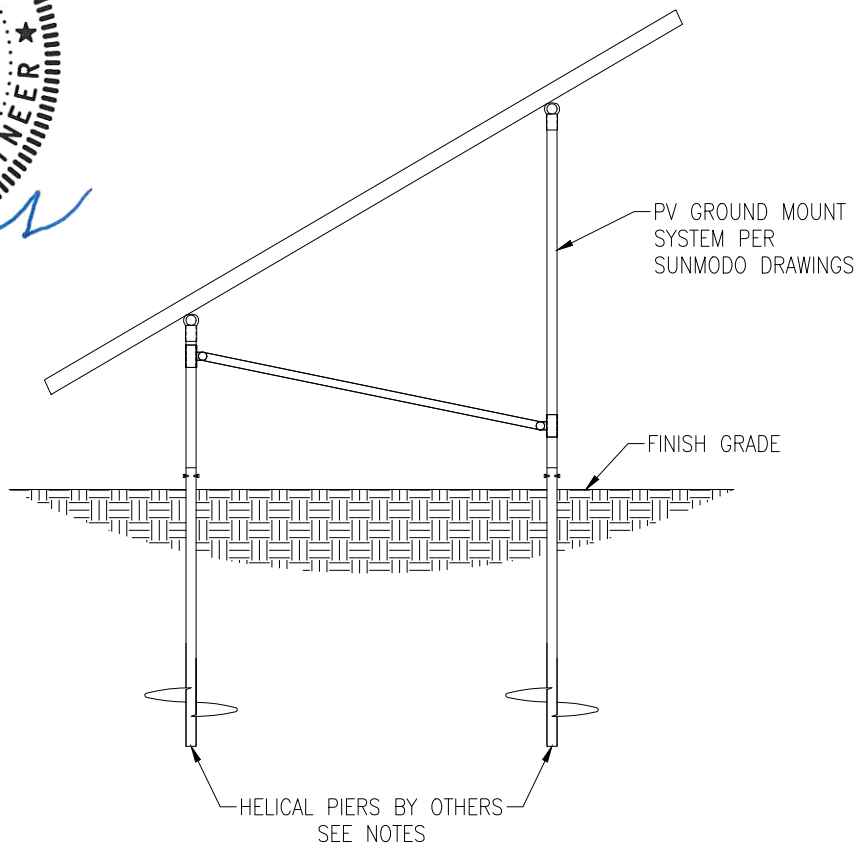
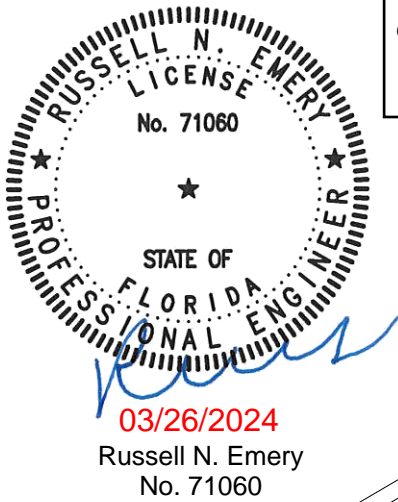

HELICAL PIER SECTION

N.T.S.

S2





JOB NO. U2716-0386-241

PROJECT SUNMODO SUNTURF GROUND MOUNT A17

SUBJECT GROUND SCREW OPTION

NOTES:

- 1. SEE SUNMODOD SHOP DRAWINGS FOR GROUND MOUNT MEMBER SIZES AND GEOMETRY
- 2. A MINIMUM OF (1) HELICAL PIER SHALL BE LOAD TESTED PER THE TEST LOADS LISTED ON THE COVER PAGE OF THIS LETTER. FAILURE CRITERIA IS AS FOLLOWS:
  - 2.1. LATERAL DEFLECTION OF 1" MEASURED AT GRADE UNDER LATERAL LOAD
  - 2.2. VERTICAL DEFLECTION OF 1/2" UNDER AXIAL LOAD
- 3. LOAD TESTS SHALL BE PERFORMED BY A LICENSED CONTRACTOR AS APPROVED BY THE AHJ

Vector Structural Engineering requires that we review each site-specific install, and we are not liable for installs at site-specific locations we have not reviewed. This document does not address site-specific installations.

RUSSELL N. EMERY  
 LICENSE  
 No. 71060  
 ★  
 STATE OF  
 FLORIDA  
 PROFESSIONAL ENGINEER  
 ★

[Signature]

03/26/2024

Russell N. Emery  
No. 71060

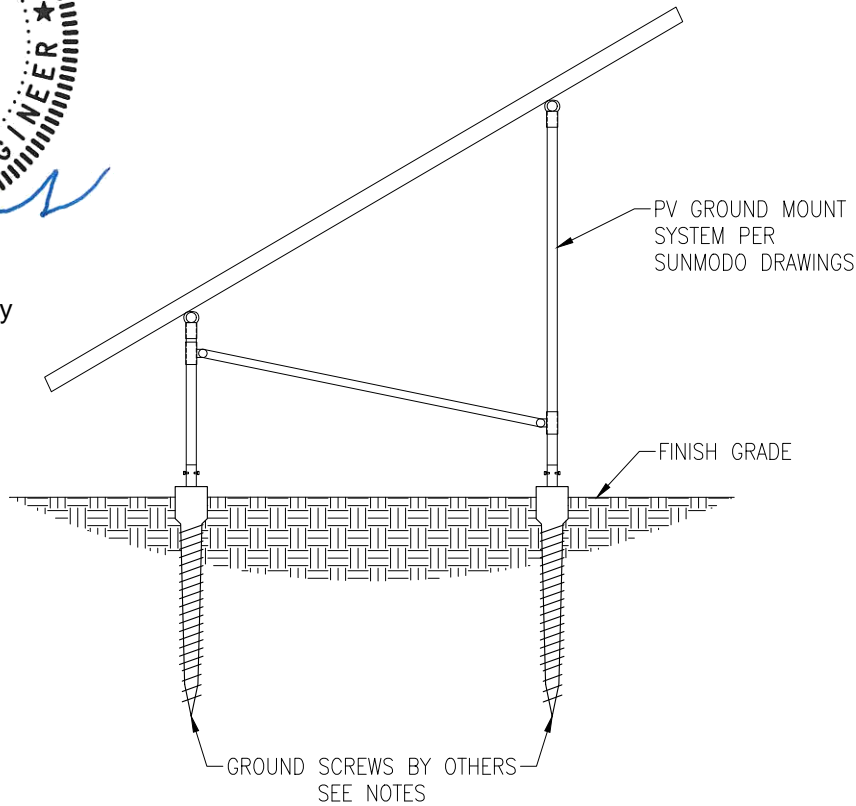

**GROUND SCREW SECTION**

N.T.S.

**S3**



JOB NO. U2716-0386-241

PROJECT SUNMODO SUNTURF GROUND MOUNT A17

SUBJECT BALLAST BLOCK OPTION

NOTES:

- SEE SUNMODO SHOP DRAWINGS FOR GROUND MOUNT MEMBER SIZES AND GEOMETRY

Vector Structural Engineering requires that we review each site-specific install, and we are not liable for installs at site-specific locations we have not reviewed. This document does not address site-specific installations.

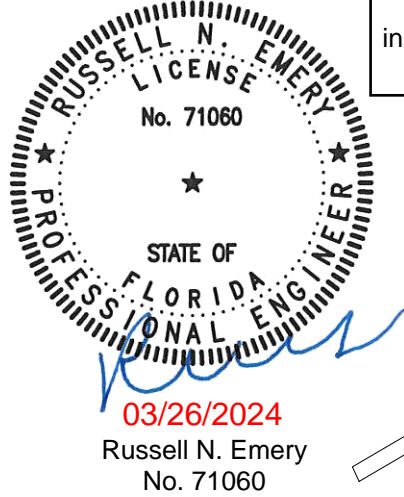

03/26/2024  
Russell N. Emery  
No. 71060

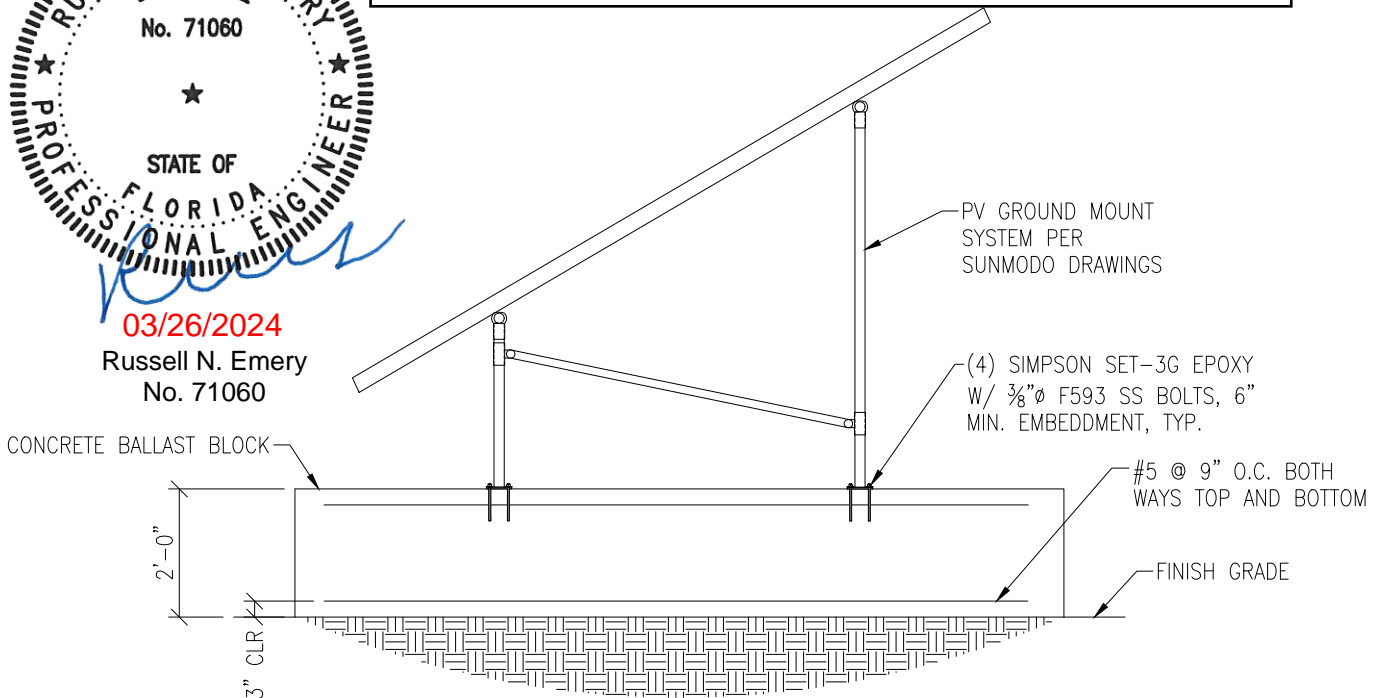

SECTION VIEW

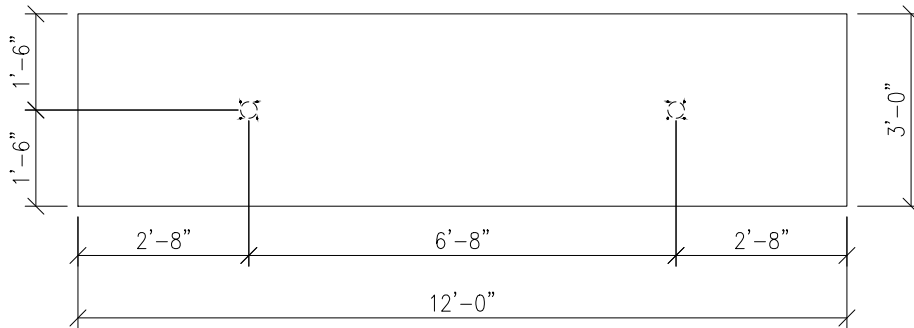

PLAN VIEW

**BALLAST BLOCK SECTION**

N.T.S.

**S4**



JOB NO.: U2716.0386.241

**PROJECT:** Sunturf Package A17 Ground Mount

---

# DESIGN LOADS



**JOB NO.:** U2716.0386.241  
**SUBJECT:** SNOW LOADS  
**CONDITION:** 35° TILT

**PROJECT:** Sunturf Package A17 Ground Mount

**SNOW LOADS**

Calculations Per:	ASCE 7-22	
Snow Ground Load, $p_g$ [psf]:	70.0	(Section 7.2)
Risk Category:	I	(Table 1.5-1)
Terrain Category:	B	(Section 26.7)
Exposure of Roof:	Fully Exposed	(Table 7-2)
Exposure Factor, $C_e$ :	0.9	(Table 7-2)
Thermal Factor, $C_t$ :	1.2	(Table 7-3)
Flat Roof Snow Load, $p_f$ [psf]:	53	(Equation 7.3-1)
Min. Roof Snow Load, $p_m$ [psf]:	25	(Section 7.3.3)
Panel Slope from Horizontal [°]:	35.0	
Unobstructed Slippery Surface?	Yes	(Section 7.4)
Slope Factor Figure:	Figure 7-2c	(Section 7.4)
Roof Slope Factor, $C_s$ :	0.64	
Sloped Roof Snow Load, $p_s$ [psf]:	34	(Equation 7.4-1)
Array Width [ft]	15.0	
Required Leading Edge Height [ft]	3.9	
Leading Edge Height [ft]	3.0	
Design Snow Load, $S$ [psf]:	53	(1.0 Snow)



**JOB NO.:** U2716.0386.241  
**SUBJECT:** WIND PRESSURES  
**CONDITION:** 35° TILT

**PROJECT:** Sunturf Package A17 Ground Mount

**WIND PRESSURES**

Calculations per:	ASCE 7-22	
Design Wind Speed, V [mph]:	140	
Risk Category:	I	(Table 1.5-1)
Exposure Category:	B	(Section 26.7)
Elevation [ft]:	-156.2	
Ground Elevation Factor, $K_e$ :		(Not applicable)
$\alpha$ :	7.5	(Table 26.11-1)
$z_g$ [ft]:	3280	(Table 26.11-1)
Velocity Pressure Exposure Coefficient, $K_h$ :	0.57	(Table 26.10-1)
Topographic Factor, $K_{ht}$ :	1.0	(Section 26.8)
Wind Directionality Factor, $K_d$ :	0.85	(Table 26.6-1)
Internal Pressure Coefficient, $GC_{pi}$ :	0.00	(Figure 26.13-1)
Velocity Pressure, $q_h$ [psf]:	28.75	(Equation 26.10-1)
Gust Effect Factor, G:	0.85	(Section 26.11.4)
Panel Slope [degrees]:	35.0	
Wind Flow:	Clear	
Roof Configuration:	Monoslope	

Wind Pressures in Transverse (N-S) Direction

Net Pressure Coefficients per Figure 27.3-4

Clear Wind Flow	$C_{NW}$	$C_{NL}$
Case 1 ( $\gamma = 0^\circ$ , Load Case A)	-1.8	-1.8
Case 2 ( $\gamma = 0^\circ$ , Load Case B)	-2.4	-0.6
Case 3 ( $\gamma = 180^\circ$ , Load Case A)	2.1	2.1
Case 4 ( $\gamma = 180^\circ$ , Load Case B)	2.7	1.1

Design Wind Pressures per Equation 27.3-2 [psf]

Clear Wind Flow	$k_d q_h GC_{NW}$	$k_d q_h GC_{NL}$
Case 1 ( $\gamma = 0^\circ$ , Load Case A)	-37.4	-37.4
Case 2 ( $\gamma = 0^\circ$ , Load Case B)	-49.8	-12.5
Case 3 ( $\gamma = 180^\circ$ , Load Case A)	43.6	43.6
Case 4 ( $\gamma = 180^\circ$ , Load Case B)	56.1	22.8
Case 5 ( $\gamma = 0^\circ$ , 16 psf Min. Horiz.)	-16.0	-16.0
Case 6 ( $\gamma = 180^\circ$ , 16 psf Min. Horiz.)	16.0	16.0



**JOB NO.:** U2716.0386.241  
**SUBJECT:** SNOW LOADS  
**CONDITION:** 20° TILT

**PROJECT:** Sunturf Package A17 Ground Mount

**SNOW LOADS**

Calculations Per:	ASCE 7-22	
Snow Ground Load, $p_g$ [psf]:	70.0	(Section 7.2)
Risk Category:	I	(Table 1.5-1)
Terrain Category:	B	(Section 26.7)
Exposure of Roof:	Fully Exposed	(Table 7-2)
Exposure Factor, $C_e$ :	0.9	(Table 7-2)
Thermal Factor, $C_t$ :	1.2	(Table 7-3)
Flat Roof Snow Load, $p_f$ [psf]:	53	(Equation 7.3-1)
Min. Roof Snow Load, $p_m$ [psf]:	25	(Section 7.3.3)
Panel Slope from Horizontal [°]:	20.0	
Unobstructed Slippery Surface?	Yes	(Section 7.4)
Slope Factor Figure:	Figure 7-2c	(Section 7.4)
Roof Slope Factor, $C_s$ :	0.91	
Sloped Roof Snow Load, $p_s$ [psf]:	48	(Equation 7.4-1)
Array Width [ft]	15.0	
Required Leading Edge Height [ft]	3.9	
Leading Edge Height [ft]	3.0	
Design Snow Load, $S$ [psf]:	53	(1.0 Snow)



**JOB NO.:** U2716.0386.241  
**SUBJECT:** WIND PRESSURES  
**CONDITION:** 20° TILT

**PROJECT:** Sunturf Package A17 Ground Mount

**WIND PRESSURES**

Calculations per:	ASCE 7-22	
Design Wind Speed, V [mph]:	140	
Risk Category:	I	(Table 1.5-1)
Exposure Category:	B	(Section 26.7)
Elevation [ft]:	-156.2	
Ground Elevation Factor, $K_e$ :		(Not applicable)
$\alpha$ :	7.5	(Table 26.11-1)
$z_g$ [ft]:	3280	(Table 26.11-1)
Velocity Pressure Exposure Coefficient, $K_h$ :	0.57	(Table 26.10-1)
Topographic Factor, $K_{ht}$ :	1.0	(Section 26.8)
Wind Directionality Factor, $K_d$ :	0.85	(Table 26.6-1)
Internal Pressure Coefficient, $GC_{pi}$ :	0.00	(Figure 26.13-1)
Velocity Pressure, $q_h$ [psf]:	28.75	(Equation 26.10-1)
Gust Effect Factor, G:	0.85	(Section 26.11.4)
Panel Slope [degrees]:	20.0	
Wind Flow:	Clear	
Roof Configuration:	Monoslope	

Wind Pressures in Transverse (N-S) Direction

Net Pressure Coefficients per Figure 27.3-4

Clear Wind Flow	$C_{NW}$	$C_{NL}$
Case 1 ( $\gamma = 0^\circ$ , Load Case A)	-1.3	-1.5
Case 2 ( $\gamma = 0^\circ$ , Load Case B)	-2.2	-0.2
Case 3 ( $\gamma = 180^\circ$ , Load Case A)	1.6	1.7
Case 4 ( $\gamma = 180^\circ$ , Load Case B)	2.1	0.7

Design Wind Pressures per Equation 27.3-2 [psf]

Clear Wind Flow	$k_d q_h GC_{NW}$	$k_d q_h GC_{NL}$
Case 1 ( $\gamma = 0^\circ$ , Load Case A)	-27.0	-31.2
Case 2 ( $\gamma = 0^\circ$ , Load Case B)	-45.7	-4.2
Case 3 ( $\gamma = 180^\circ$ , Load Case A)	33.2	35.3
Case 4 ( $\gamma = 180^\circ$ , Load Case B)	43.6	14.5
Case 5 ( $\gamma = 0^\circ$ , 16 psf Min. Horiz.)	-16.0	-16.0
Case 6 ( $\gamma = 180^\circ$ , 16 psf Min. Horiz)	16.0	16.0



JOB NO.: U2716.0386.241

**PROJECT:** Sunturf Package A17 Ground Mount

---

# RACKING ANALYSIS



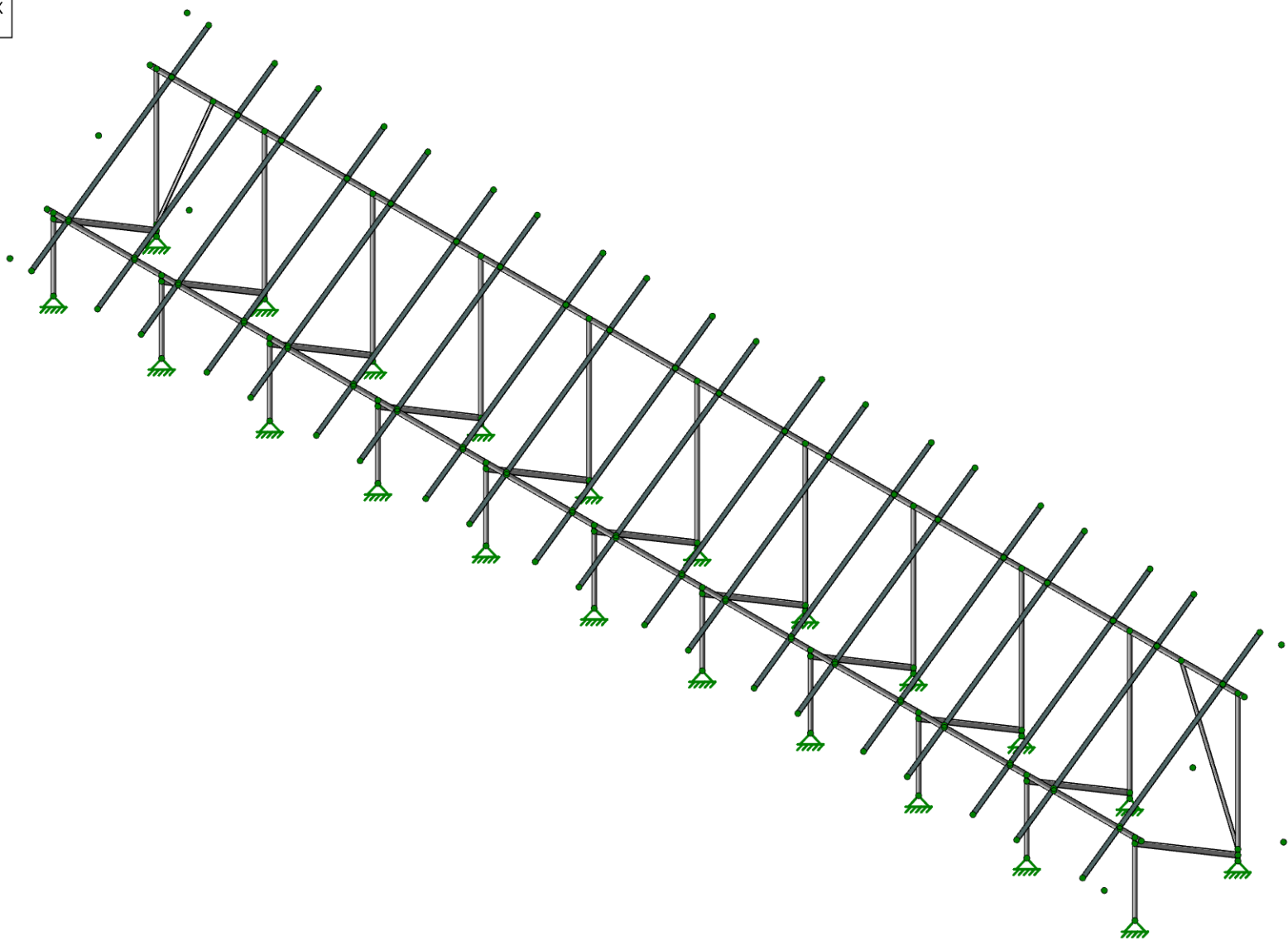
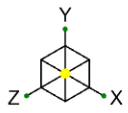

Vector Structural Engineering  
MIH  
U2716.0386.241

A17 Standard Panels - 35 Degree Tilt

SK-1  
Mar 25, 2024 at 03:22 PM  
Sunturf A17 - SP - 35deg.r3d

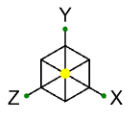

Section Sets	
<span style="color: blue;">█</span>	Post
<span style="color: green;">█</span>	Cross Beam
<span style="color: red;">█</span>	Diagonal Brace
<span style="color: grey;">█</span>	Double Brace
<span style="color: magenta;">█</span>	RIGID
<span style="color: cyan;">█</span>	AL Rails

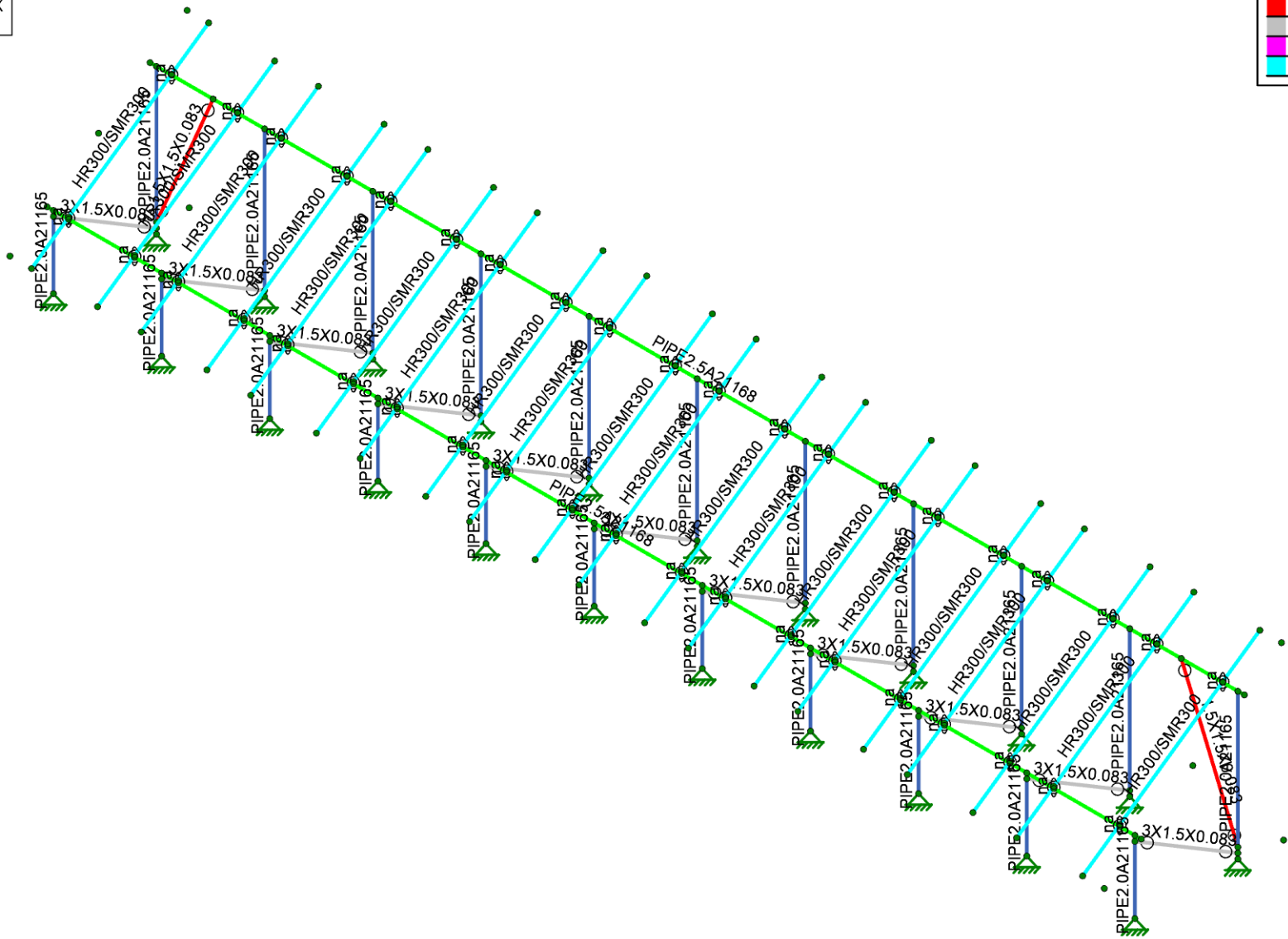

Vector Structural Engineering

MIH

U2716.0386.241

A17 Standard Panels - 35 Degree Tilt

SK-2

Mar 25, 2024 at 03:23 PM

Sunturf A17 - SP - 35deg.r3d

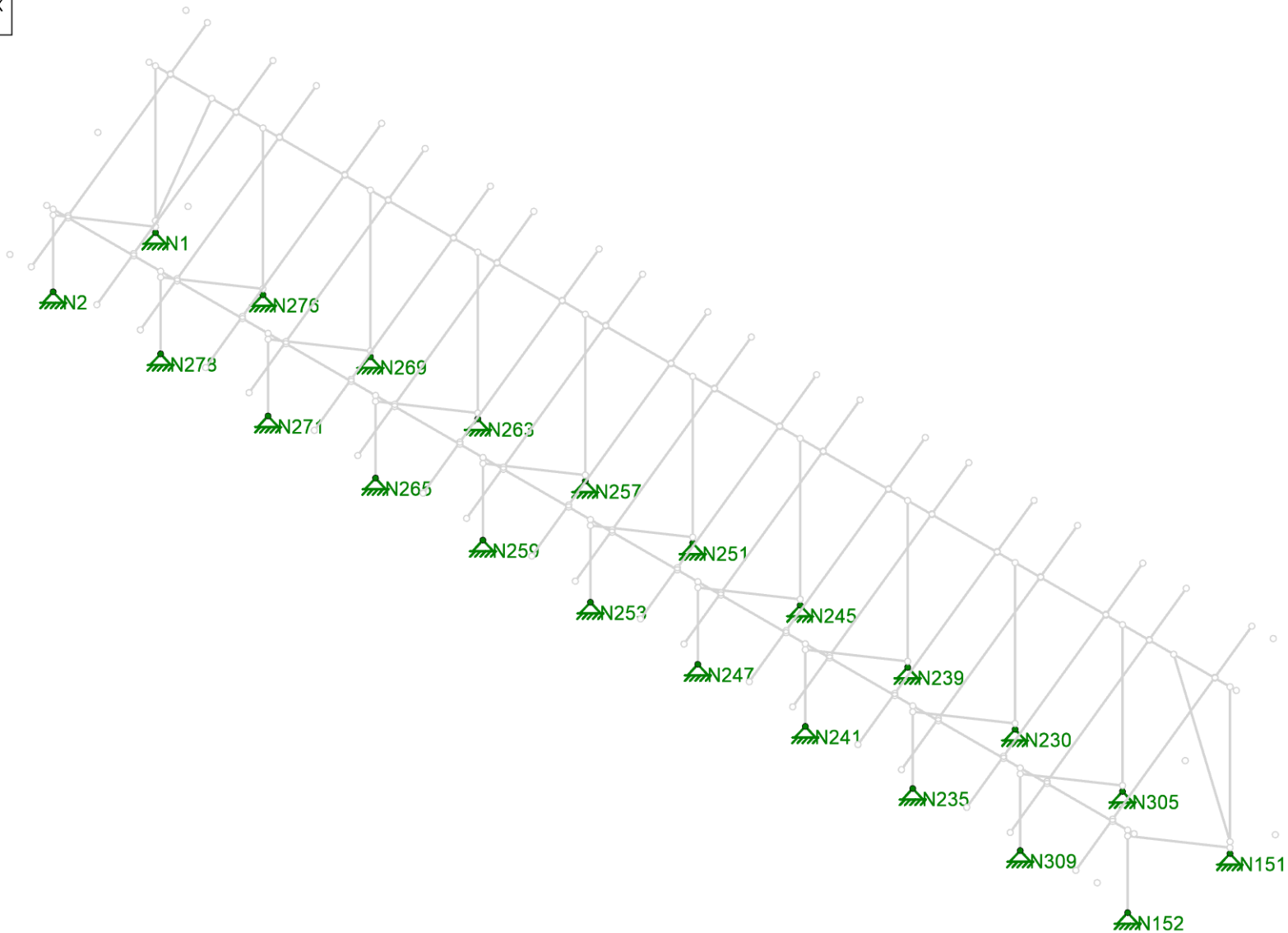
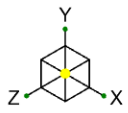

Vector Structural Engineering  
MIH  
U2716.0386.241

A17 Standard Panels - 35 Degree Tilt

SK-3  
Mar 25, 2024 at 03:23 PM  
Sunturf A17 - SP - 35deg.r3d

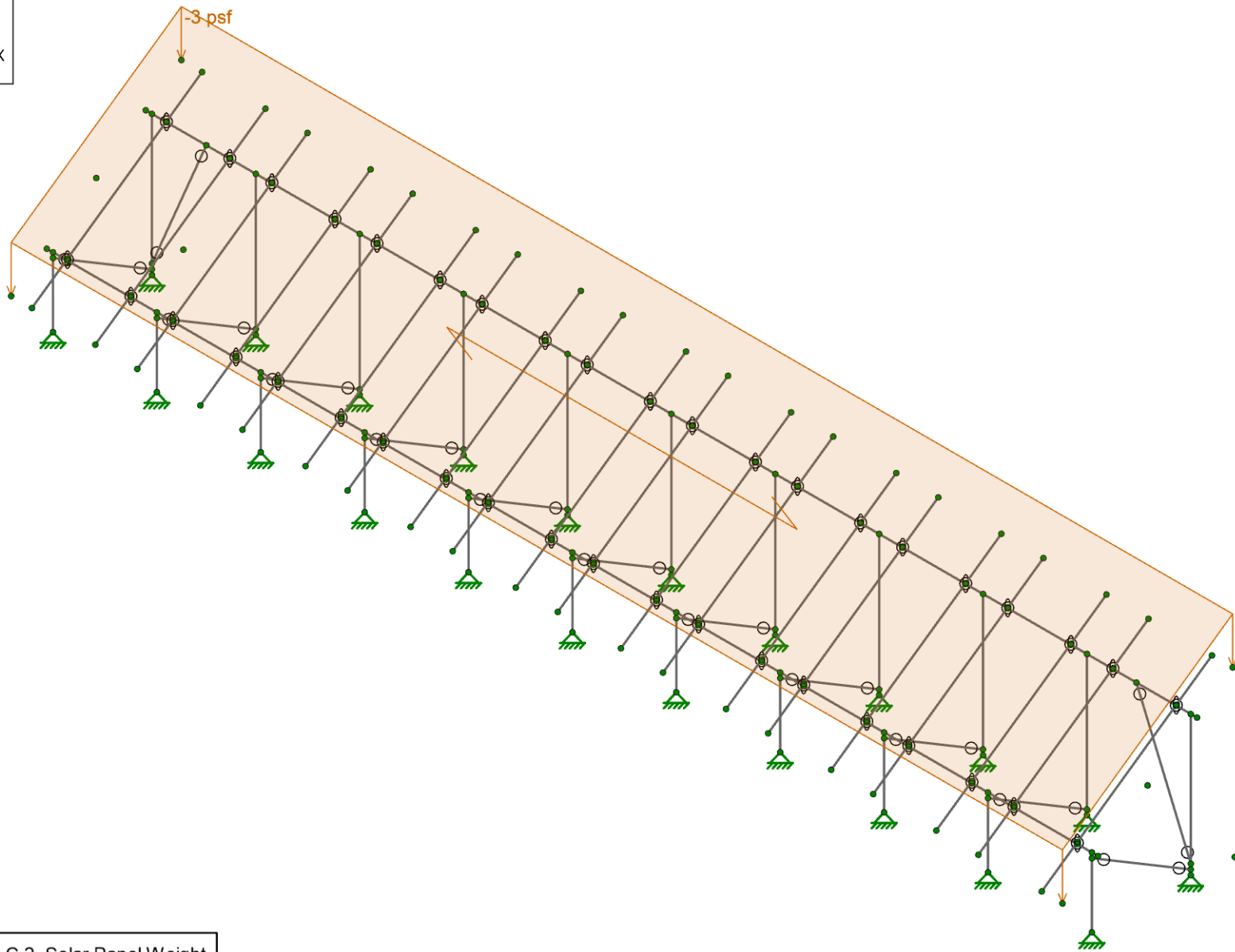
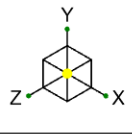

Loads: BLC 2, Solar Panel Weight



Vector Structural Engineering

MIH

U2716.0386.241

A17 Standard Panels - 35 Degree Tilt

SK-4

Mar 25, 2024 at 03:27 PM

Sunturf A17 - SP - 35deg.r3d

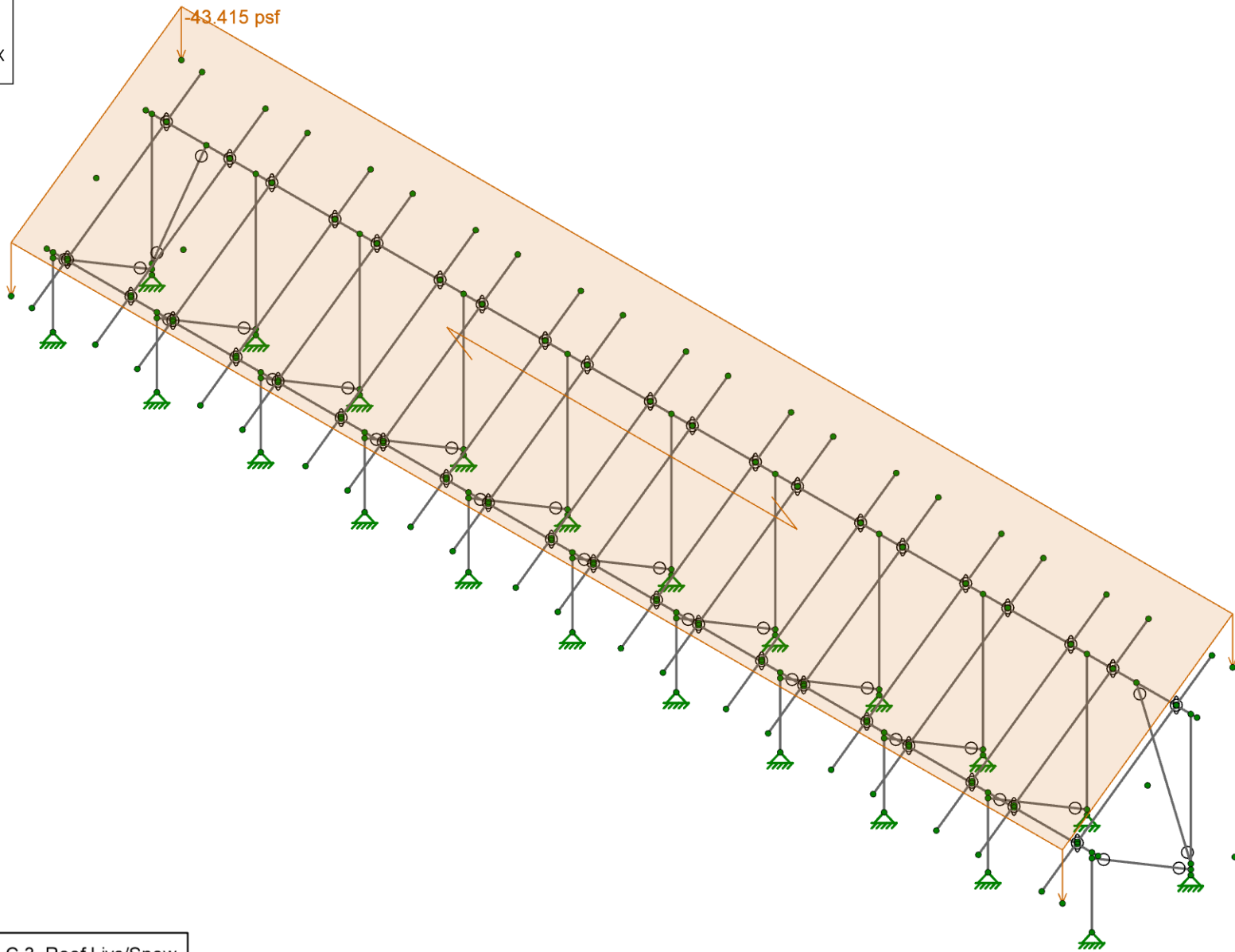
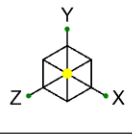

Loads: BLC 3, Roof Live/Snow



Vector Structural Engineering

MIH

U2716.0386.241

A17 Standard Panels - 35 Degree Tilt

SK-5

Mar 25, 2024 at 03:27 PM

Sunturf A17 - SP - 35deg.r3d

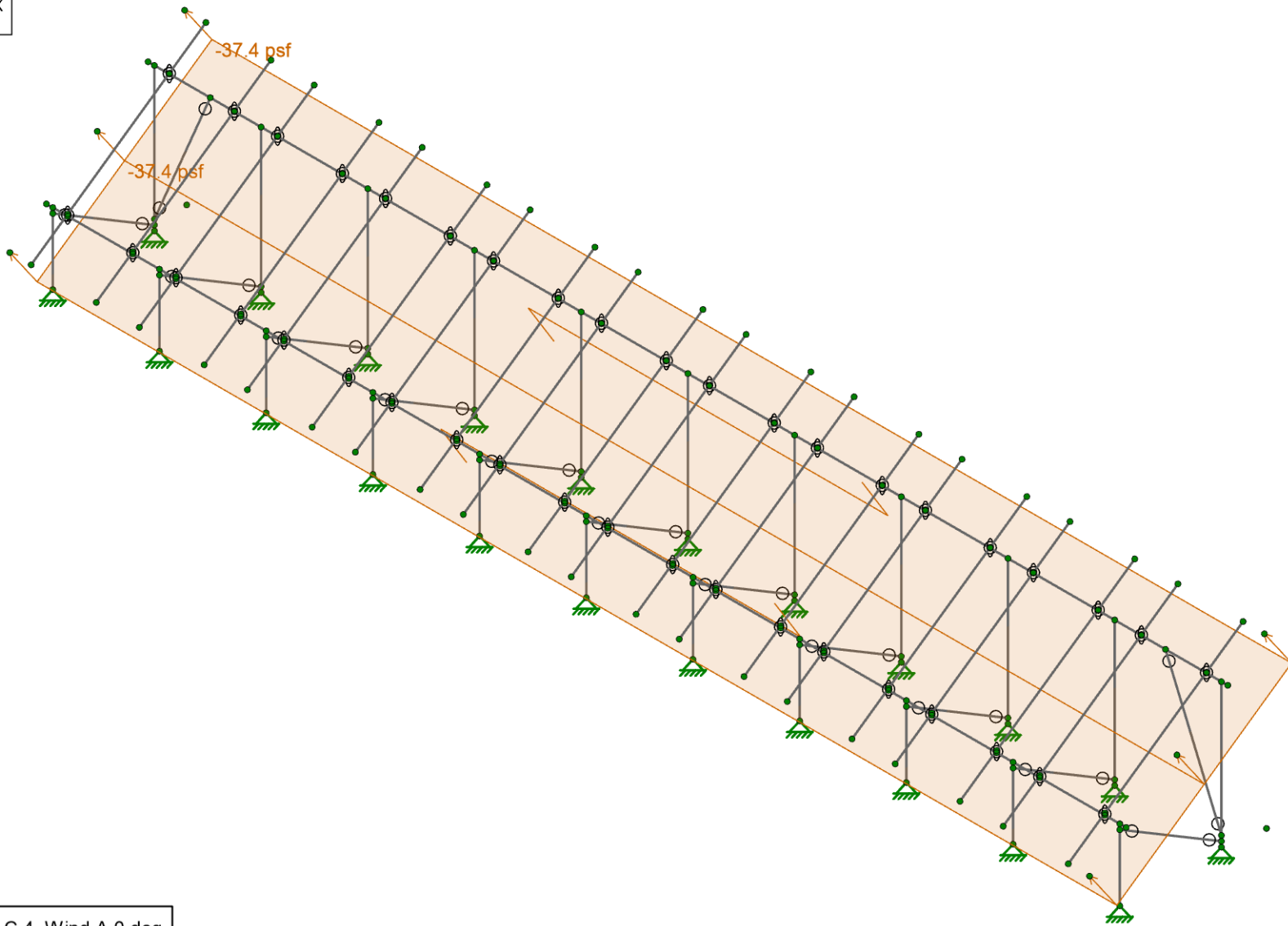
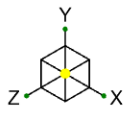

Loads: BLC 4, Wind A 0 deg



Vector Structural Engineering

MIH

U2716.0386.241

A17 Standard Panels - 35 Degree Tilt

SK-6

Mar 25, 2024 at 03:28 PM

Sunturf A17 - SP - 35deg.r3d

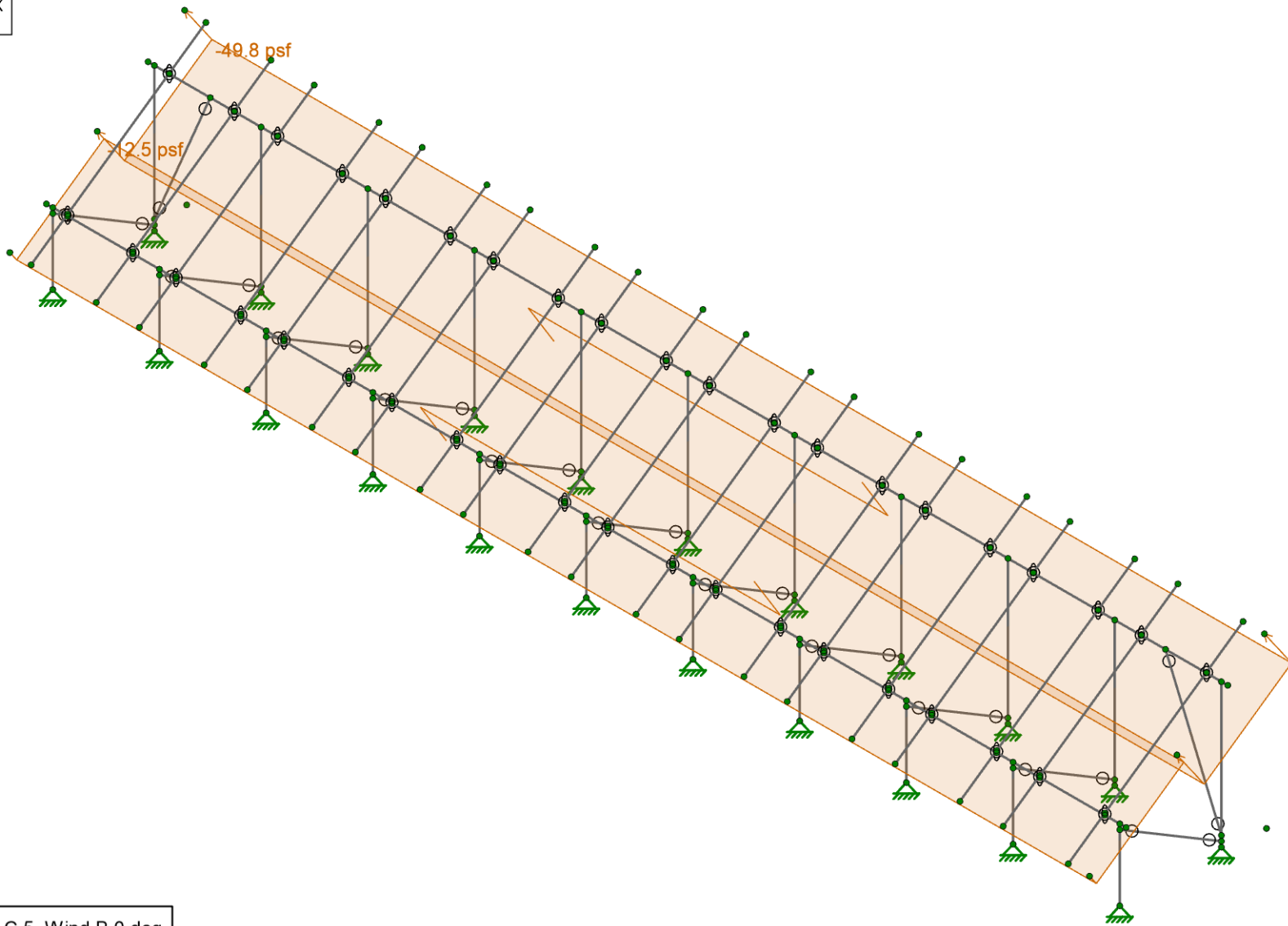
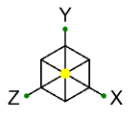

Loads: BLC 5, Wind B 0 deg



Vector Structural Engineering

MIH

U2716.0386.241

A17 Standard Panels - 35 Degree Tilt

SK-7

Mar 25, 2024 at 03:28 PM

Sunturf A17 - SP - 35deg.r3d

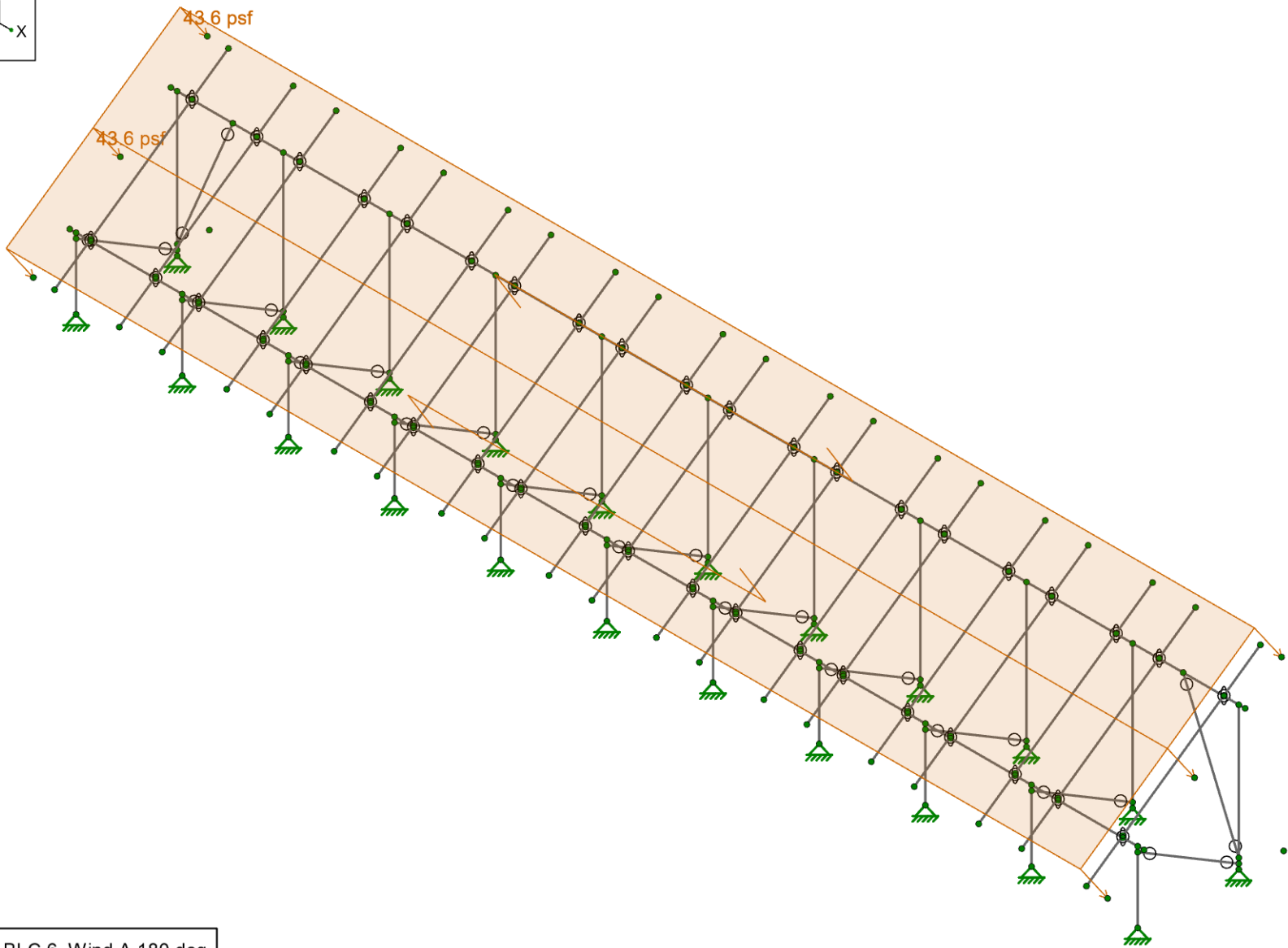
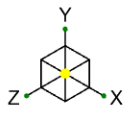

Loads: BLC 6, Wind A 180 deg



Vector Structural Engineering

MIH

U2716.0386.241

A17 Standard Panels - 35 Degree Tilt

SK-8

Mar 25, 2024 at 03:28 PM

Sunturf A17 - SP - 35deg.r3d



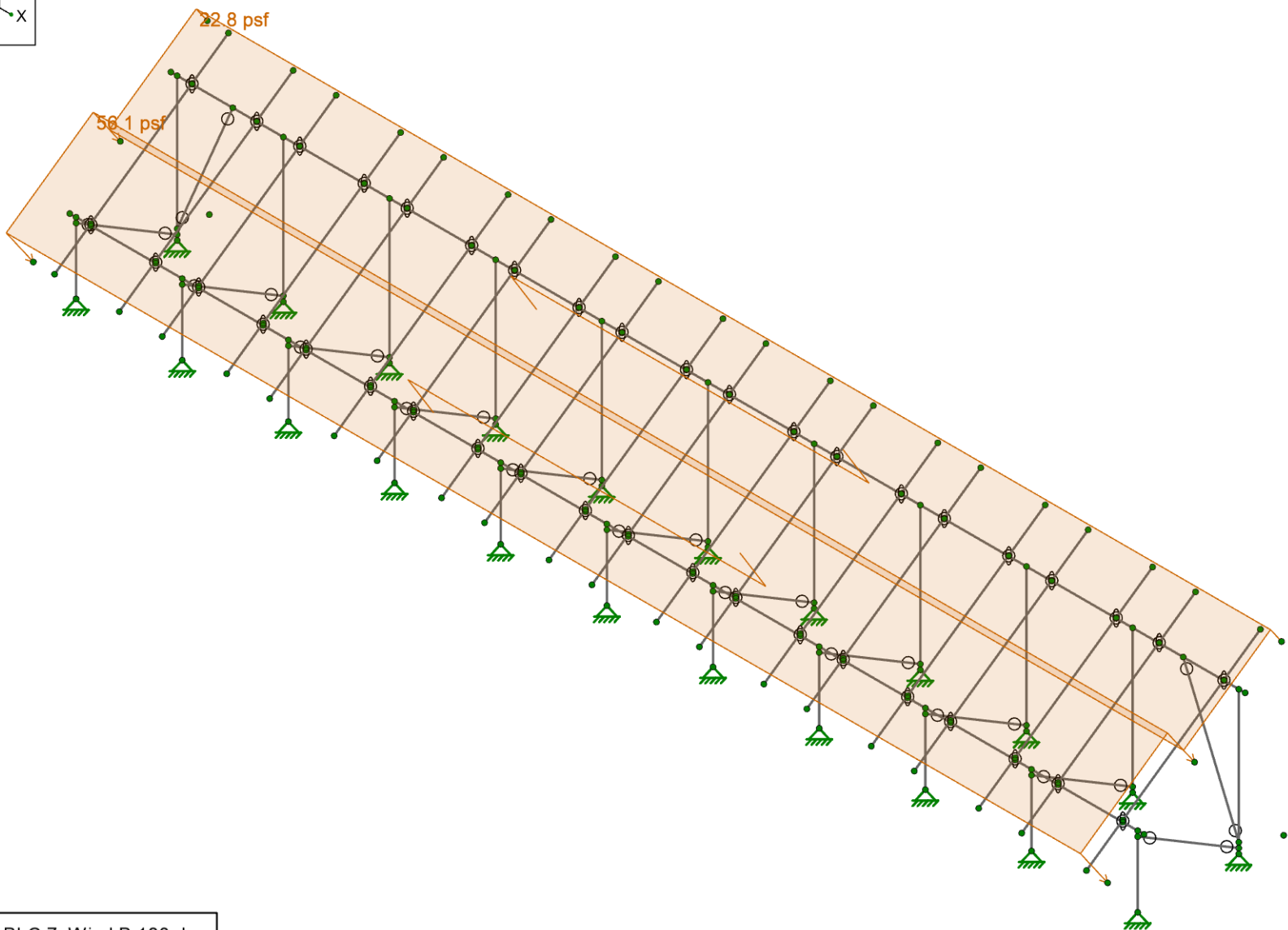
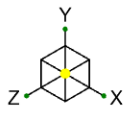

Loads: BLC 7, Wind B 180 deg



Vector Structural Engineering

MIH

U2716.0386.241

A17 Standard Panels - 35 Degree Tilt

SK-9

Mar 25, 2024 at 03:29 PM

Sunturf A17 - SP - 35deg.r3d

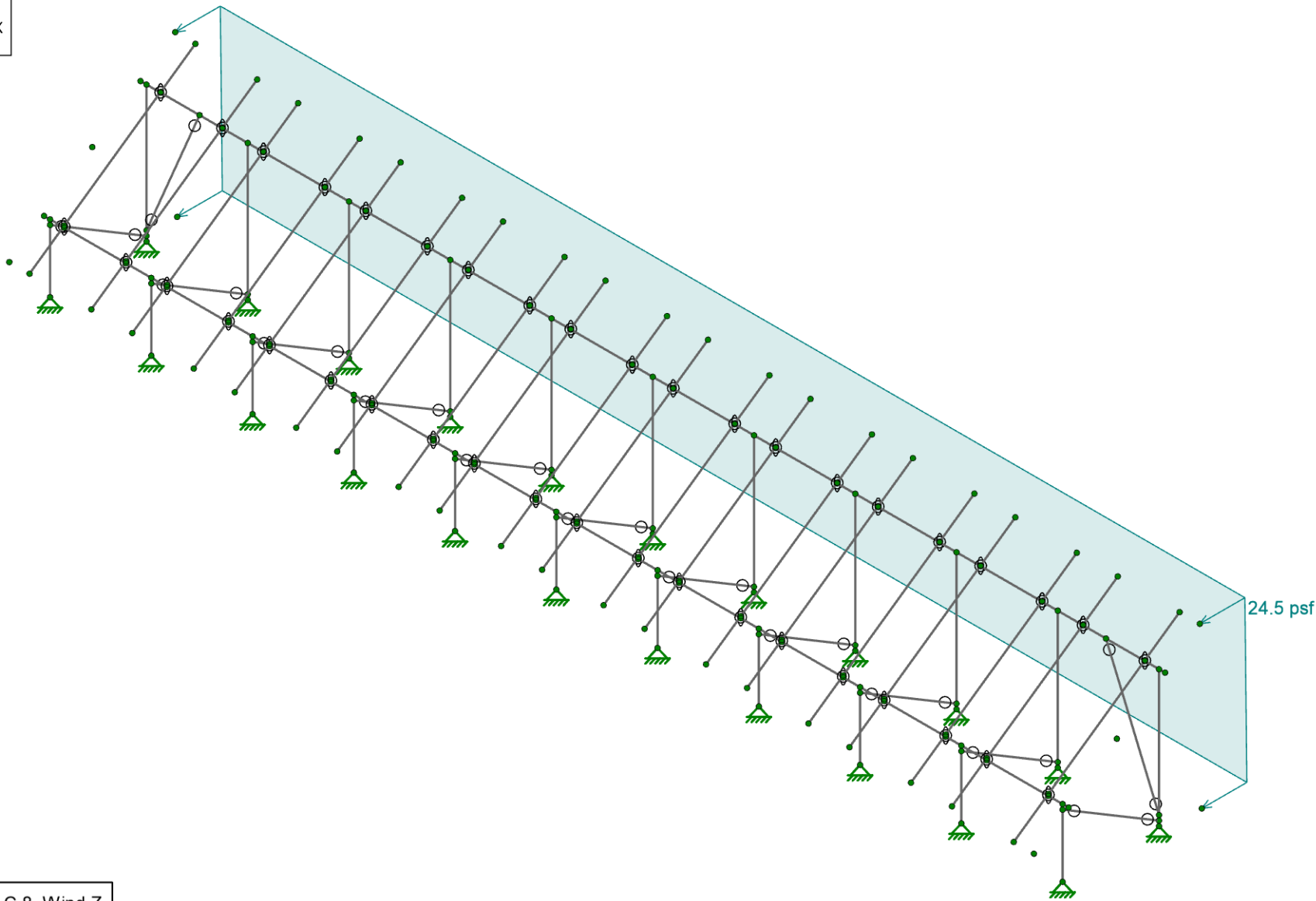
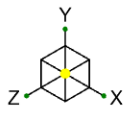

Loads: BLC 8, Wind Z



Vector Structural Engineering

MIH

U2716.0386.241

A17 Standard Panels - 35 Degree Tilt

SK-10

Mar 25, 2024 at 03:29 PM

Sunturf A17 - SP - 35deg.r3d

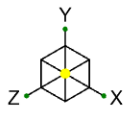

Code Check (Env)	
Black	No Calc
Red	> 1.0
Magenta	.90-1.0
Green	.75-90
Cyan	.50-.75
Blue	0-.50

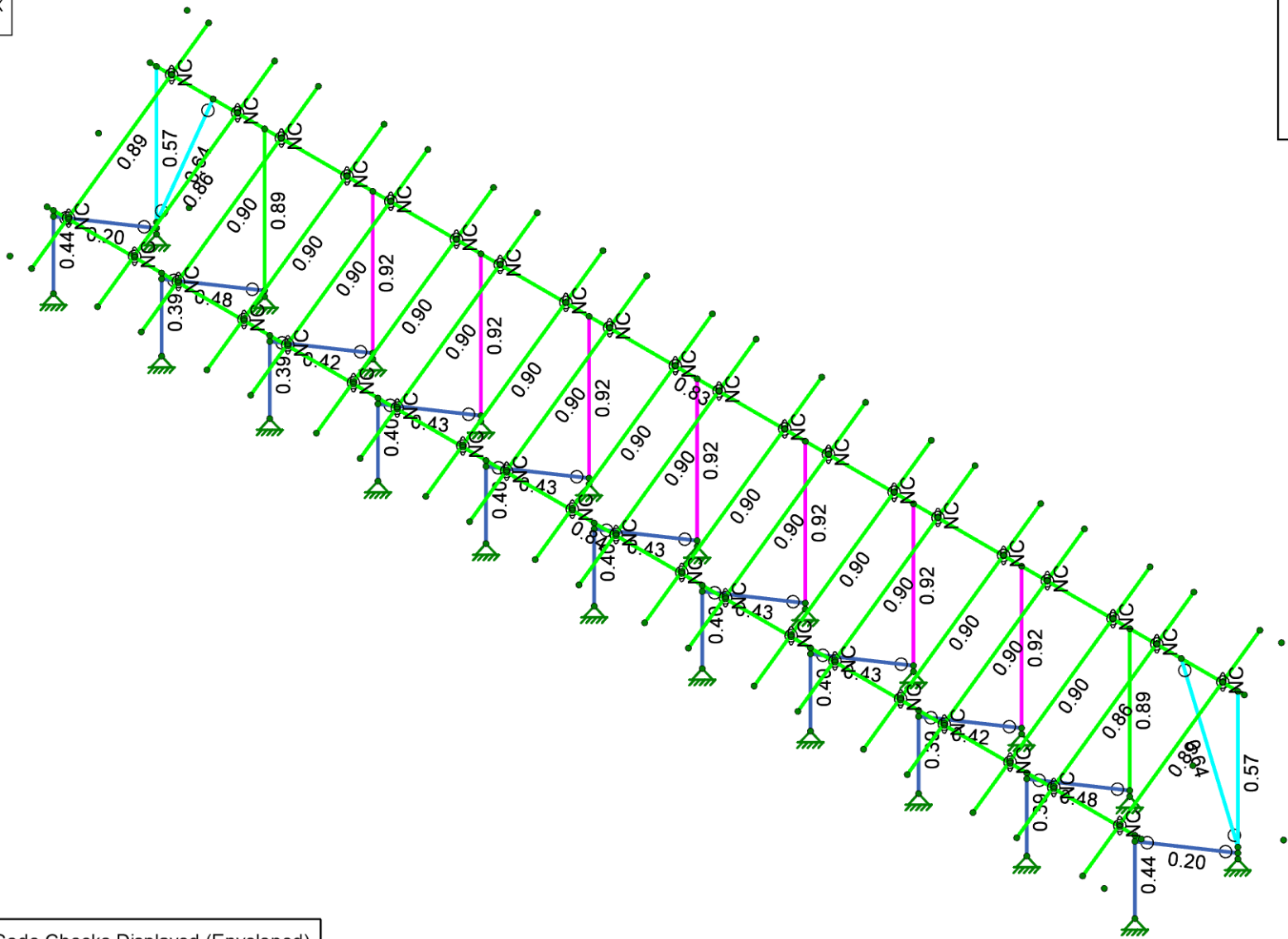

Member Code Checks Displayed (Enveloped)

 <small>A NEMETSCHek COMPANY</small>	Vector Structural Engineering	A17 Standard Panels - 35 Degree Tilt	SK-11
	MIH		Mar 25, 2024 at 03:30 PM
	U2716.0386.241		Sunturf A17 - SP - 35deg.r3d

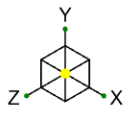

Shear Check  
(Env)

- No Calc
- > 1.0
- .90-1.0
- .75-.90
- .50-.75
- 0-.50

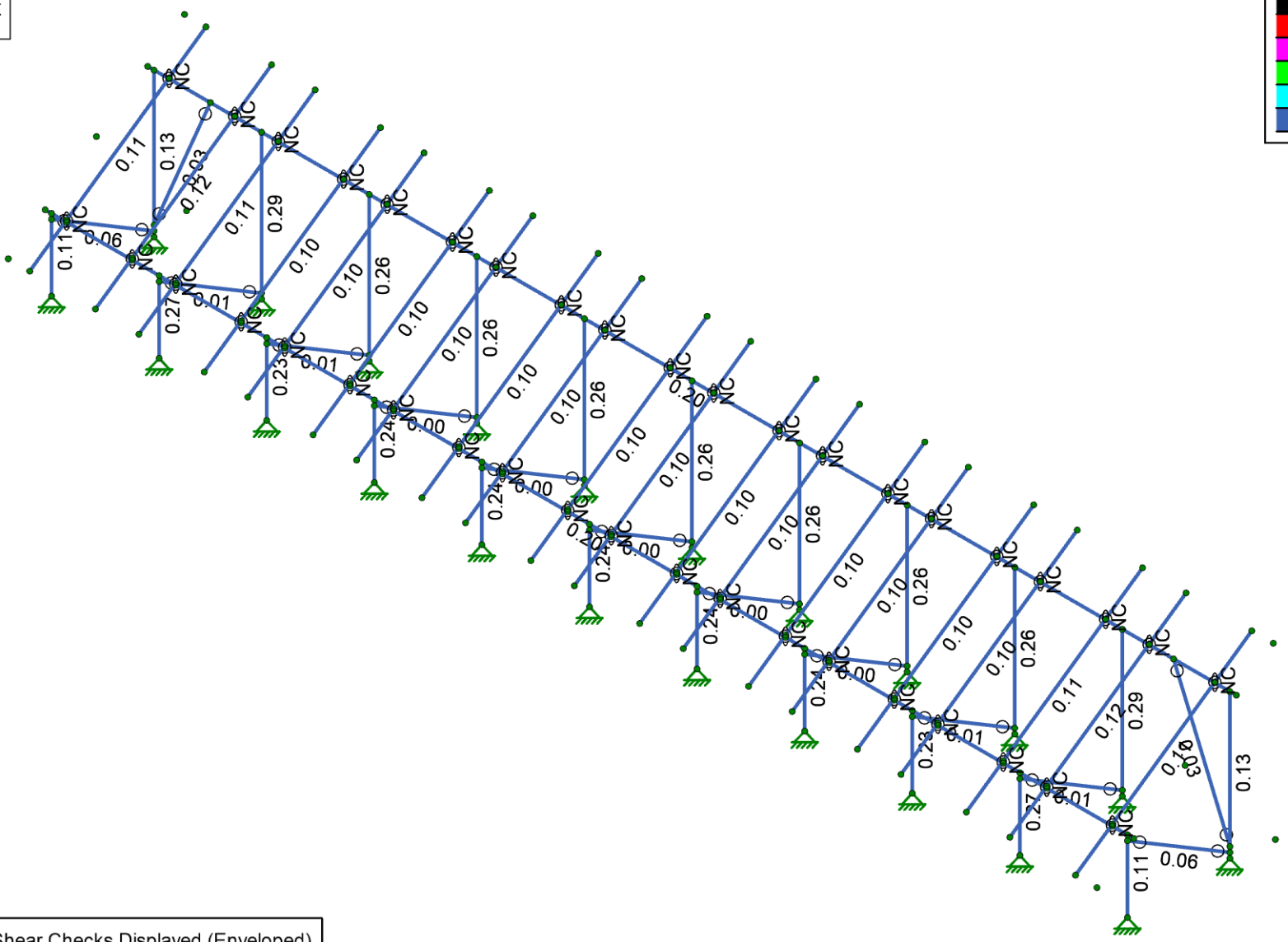

Member Shear Checks Displayed (Enveloped)

 A NEMETSCHek COMPANY	Vector Structural Engineering	A17 Standard Panels - 35 Degree Tilt	SK-12
	MIH		Mar 25, 2024 at 03:30 PM
	U2716.0386.241		Sunturf A17 - SP - 35deg.r3d

**Model Settings**

Number of Reported Sections	5
Number of Internal Sections	100
Member Area Load Mesh Size (in <sup>2</sup> )	144
Consider Shear Deformation	Yes
Consider Torsional Warping	Yes
Approximate Mesh Size (in)	24
Transfer Forces Between Intersecting Wood Walls	Yes
Increase Wood Wall Nailing Capacity for Wind Loads	Yes
Include P-Delta for Walls	Yes
Optimize Masonry and Wood Walls	Yes
Maximum Number of Iterations	3
Single	No
Multiple (Optimum)	Yes
Maximum	No

Global Axis corresponding to vertical direction	Y
Convert Existing Data	Yes
Default Global Plane for z-axis	XZ
Plate Local Axis Orientation	Nodal

Hot Rolled Steel	AISC 15th (360-16): ASD
Stiffness Adjustment	Yes (Iterative)
Notional Annex	None
Connections	None
Cold Formed Steel	None
Stiffness Adjustment	Yes (Iterative)
Wood	None
Temperature	< 100F
Concrete	ACI 318-14
Masonry	None
Aluminum	AA ADM1-15: ASD
Structure Type	Building
Stiffness Adjustment	Yes (Iterative)
Stainless	None
Stiffness Adjustment	Yes (Iterative)

Analysis Methodology	Exact Integration Method
Parme Beta Factor	0.65

Compression Stress Block	Rectangular Stress Block
Analyze using Cracked Sections	No
Leave room for horizontal rebar splices (2*d bar spacing)	Yes
List forces which were ignored for design in the Detail Report	Yes

Column Min Steel	1
Column Max Steel	8
Rebar Material Spec	ASTM A615
Warn if beam-column framing arrangement is not understood	No
Number of Shear Regions	4
Region 2 & 3 Spacing Increase Increment (in)	3.999992

Code	None
------	------



Company : Vector Structural Engineering  
Designer : MIH  
Job Number : U2716.0386.241  
Model Name : A17 Standard Panels - 35 Degre...

3/25/2024  
3:33:40 PM  
Checked By : \_\_\_\_\_

**Model Settings (Continued)**

Base Elevation (ft)	15600
Include the weight of the structure in base shear calcs	Yes
T Z (sec)	
T X (sec)	
CZ	0.02
CX	0.02
R Z	3
R X	3

**Hot Rolled Steel Properties**

	Label	E [ksi]	G [ksi]	Nu	Therm. Coeff. [1e <sup>5</sup> F <sup>-1</sup> ]	Density [lb/ft <sup>3</sup> ]	Yield [psi]	Ry	Fu [psi]	Rt
1	A992	29000	11154	0.3	0.65	490	50000	1.1	65000	1.1
2	A36 Gr.36	29000	11154	0.3	0.65	490	36000	1.5	58000	1.2
3	A572 Gr.50	29000	11154	0.3	0.65	490	50000	1.1	65000	1.1
4	A500 Gr.B RND	29000	11154	0.3	0.65	527	42000	1.4	58000	1.3
5	A500 Gr.B Rect	29000	11154	0.3	0.65	527	46000	1.4	58000	1.3
6	A53 Gr.B	29000	11154	0.3	0.65	490	35000	1.6	60000	1.2
7	A1085	29000	11154	0.3	0.65	490	50000	1.4	65000	1.3

**Aluminum Properties**

	Label	E [ksi]	G [ksi]	Nu	Therm. Coeff. [1e <sup>5</sup> F <sup>-1</sup> ]	Density [lb/ft <sup>3</sup> ]	Table B.4	kt	Ftu [psi]	Fty [psi]	Fcy [psi]	Fsu [psi]	Ct
1	3003-H14	10100	3787.5	0.33	1.3	172.8	Table B.4-1	1	19000	16000	13000	12000	141
2	6061-T6	10100	3787.5	0.33	1.3	172.8	Table B.4-2	1	38000	35000	35000	24000	141
3	6063-T5	10100	3787.5	0.33	1.3	172.8	Table B.4-2	1	22000	16000	16000	13000	141
4	6063-T6	10100	3787.5	0.33	1.3	172.8	Table B.4-2	1	30000	25000	25000	19000	141
5	5052-H34	10200	3787.5	0.33	1.3	172.8	Table B.4-1	1	34000	26000	24000	20000	141
6	6061-T6 W	10100	3787.5	0.33	1.3	172.8	Table B.4-1	1	24000	15000	15000	15000	141
7	6005-T5	10100	3787.5	0.33	1.3	172.8	Table B.4-1	1	38000	35000	35000	24000	141

**Hot Rolled Steel Section Sets**

	Label	Shape	Type	Design List	Material	Design Rule	Area [in <sup>2</sup> ]	Iyy [in <sup>4</sup> ]	Izz [in <sup>4</sup> ]	J [in <sup>4</sup> ]
1	Post	PIPE2.0A21165	Column	Pipe	A572 Gr.50	Typical	0.776	0.499	0.499	0.998
2	Cross Beam	PIPE2.5A21168	Beam	Wide Flange	A572 Gr.50	Typical	0.947	0.907	0.907	1.814
3	Diagonal Brace	1.5X1.5X0.083	HBrace	SquareTube	A572 Gr.50	Typical	0.47	0.158	0.158	0.236
4	Double Brace	3x1.5x0.083	HBrace	Tube	A572 Gr.50	Typical	0.719	0.283	0.845	0.654

**Aluminum Section Sets**

	Label	Shape	Type	Design List	Material	Design Rule	Area [in <sup>2</sup> ]	Iyy [in <sup>4</sup> ]	Izz [in <sup>4</sup> ]	J [in <sup>4</sup> ]
1	AL Posts	2.375ODX0.188	Column	Pipe	6005-T5	Typical	1.29	0.778	0.778	1.54
2	AL Brace	RT1.5X2X0.15625	VBrace	Rectangular Tubes	6005-T5	Typical	0.996	0.327	0.524	0.602
3	AL Rails	HR300/SMR300	Beam	Rectangular Tubes	6005-T5	Typical	0.736	0.214	0.727	0.734
4	AL Cross Beam	CROSSRAIL	Beam	Rectangular Tubes	6005-T5	Typical	1.909	1.97	4.366	4.017

**Basic Load Cases**

	BLC Description	Category	Y Gravity	Distributed	Area(Member)
1	Self Weight	DL	-1.05		
2	Solar Panel Weight	DL			1
3	Roof Live/Snow	RLL			1
4	Wind A 0 deg	OL1			2
5	Wind B 0 deg	OL2			2
6	Wind A 180 deg	OL3			2
7	Wind B 180 deg	OL4			2
8	Wind Z	WLZ			1
9	BLC 2 Transient Area Loads	None		40	
10	BLC 3 Transient Area Loads	None		40	
11	BLC 4 Transient Area Loads	None		144	
12	BLC 5 Transient Area Loads	None		144	
13	BLC 6 Transient Area Loads	None		144	
14	BLC 7 Transient Area Loads	None		144	
15	BLC 8 Transient Area Loads	None		84	

**Load Combinations**

	Description	Solve	P-Delta	BLC	Factor	BLC	Factor	BLC	Factor	BLC	Factor
1	ASD Loads		Y								
2	1.0 D	Yes	Y	DL	1						
3	1.0 D + 1.0 S	Yes	Y	DL	1	RLL	1				
4	1.0 D + 0.6 W1	Yes	Y	DL	1	RLL		OL1	0.6	WLZ	0.6
5	1.0 D + 0.6 W2	Yes	Y	DL	1	RLL		OL2	0.6	WLZ	0.6
6	1.0 D + 0.6 W3	Yes	Y	DL	1	RLL		OL3	0.6	WLZ	-0.6
7	1.0 D + 0.6 W4	Yes	Y	DL	1	RLL		OL4	0.6	WLZ	-0.6
8	1.0 D + 0.45 W1 + 0.75 S	Yes	Y	DL	1	RLL	0.75	OL1	0.45	WLZ	0.45
9	1.0 D + 0.45 W2 + 0.75 S	Yes	Y	DL	1	RLL	0.75	OL2	0.45	WLZ	0.45
10	1.0 D + 0.45 W3 + 0.75 S	Yes	Y	DL	1	RLL	0.75	OL3	0.45	WLZ	-0.45
11	1.0 D + 0.45 W4 + 0.75 S	Yes	Y	DL	1	RLL	0.75	OL4	0.45	WLZ	-0.45
12	0.6 D + 0.6 W1	Yes	Y	DL	0.6	RLL		OL1	0.6	WLZ	0.6
13	0.6 D + 0.6 W2	Yes	Y	DL	0.6	RLL		OL2	0.6	WLZ	0.6
14	0.6 D + 0.6 W3	Yes	Y	DL	0.6	RLL		OL3	0.6	WLZ	-0.6
15	0.6 D + 0.6 W4	Yes	Y	DL	0.6	RLL		OL4	0.6	WLZ	-0.6
16			Y								
17	LRFD Loads		Y								
18	1.4 D		Y	DL	1.4	RLL					
19	1.2 D + 1.6 S + 0.5 W1		Y	DL	1.2	RLL	1.6	OL1	0.5		
20	1.2 D + 1.6 S + 0.5 W2		Y	DL	1.2	RLL	1.6	OL2	0.5		
21	1.2 D + 1.6 S + 0.5 W3		Y	DL	1.2	RLL	1.6	OL3	0.5		
22	1.2 D + 1.6 S + 0.5 W4		Y	DL	1.2	RLL	1.6	OL4	0.5		
23	1.2 D + 1.0 W1		Y	DL	1.2	RLL		OL1	1		
24	1.2 D + 1.0 W2		Y	DL	1.2	RLL		OL2	1		
25	1.2 D + 1.0 W3		Y	DL	1.2	RLL		OL3	1		
26	1.2 D + 1.0 W4		Y	DL	1.2	RLL		OL4	1		
27	0.9 D + 1.0 W1		Y	DL	0.9	RLL		OL1	1		
28	0.9 D + 1.0 W2		Y	DL	0.9	RLL		OL2	1		
29	0.9 D + 1.0 W3		Y	DL	0.9	RLL		OL3	1		
30	0.9 D + 1.0 W4		Y	DL	0.9	RLL		OL4	1		

**Envelope Node Reactions**

Node Label	X [lb]	LC	Y [lb]	LC	Z [lb]	LC	MX [lb-ft]	LC	MY [lb-ft]	LC	MZ [lb-ft]	LC
1 N2 max	107.56	11	1293.02	9	61.38	4	0	15	0	15	0	15
2 min	-13.67	12	-240.84	14	-72.15	6	0	2	0	2	0	2
3 N1 max	422.98	10	2498.6	10	815.66	6	0	15	0	15	0	15
4 min	-208.83	13	-1445.35	13	-711.19	4	0	2	0	2	0	2
5 N151 max	208.83	13	2498.67	10	815.74	6	0	15	0	15	0	15
6 min	-422.98	10	-1445.43	13	-711.26	4	0	2	0	2	0	2
7 N152 max	13.67	12	1293.04	9	61.38	4	0	15	0	15	0	15
8 min	-107.55	11	-240.93	14	-72.15	6	0	2	0	2	0	2
9 N305 max	6.25	13	3554.58	10	1897.68	6	0	15	0	15	0	15
10 min	-10.77	10	-2317.64	13	-1647.3	4	0	2	0	2	0	2
11 N309 max	23.94	11	2823.29	9	100.56	4	0	15	0	15	0	15
12 min	-9.07	12	-584.31	14	-114.12	6	0	2	0	2	0	2
13 N230 max	2.25	10	3918.13	10	1666.16	6	0	15	0	15	0	15
14 min	-1.14	13	-2423.57	13	-1447.48	4	0	2	0	2	0	2
15 N235 max	1.43	14	2552.55	9	101.4	4	0	15	0	15	0	15
16 min	-3.67	9	-495.15	14	-116.4	6	0	2	0	2	0	2
17 N239 max	0.44	5	3866.57	10	1714.15	6	0	15	0	15	0	15
18 min	-0.62	10	-2411.95	13	-1488.67	4	0	2	0	2	0	2
19 N241 max	2.84	10	2603.93	9	103.37	4	0	15	0	15	0	15
20 min	-2.08	12	-512.79	14	-118.54	6	0	2	0	2	0	2
21 N245 max	0.18	9	3878.25	10	1705.63	6	0	15	0	15	0	15



**Envelope Node Reactions (Continued)**

Node Label		X [lb]	LC	Y [lb]	LC	Z [lb]	LC	MX [lb-ft]	LC	MY [lb-ft]	LC	MZ [lb-ft]	LC
22		min		-0.05	14	-2415.83	13	-1481.53	4	0	2	0	2
23	N247	max		1.02	6	2595.45	9	103.54	4	0	15	0	15
24		min		-0.97	13	-510.51	14	-118.78	6	0	2	0	2
25	N251	max		0	15	3874.91	10	1707.69	6	0	15	0	15
26		min		0	12	-2414.36	13	-1483.22	4	0	2	0	2
27	N253	max		0	6	2597.02	9	103.63	4	0	15	0	15
28		min		0	12	-510.68	14	-118.88	6	0	2	0	2
29	N257	max		0.05	14	3878.2	10	1705.62	6	0	15	0	15
30		min		-0.18	9	-2415.8	13	-1481.52	4	0	2	0	2
31	N259	max		0.97	13	2595.45	9	103.54	4	0	15	0	15
32		min		-1.02	6	-510.5	14	-118.78	6	0	2	0	2
33	N263	max		0.62	10	3866.54	10	1714.14	6	0	15	0	15
34		min		-0.44	5	-2411.94	13	-1488.66	4	0	2	0	2
35	N265	max		2.08	12	2603.92	9	103.37	4	0	15	0	15
36		min		-2.84	10	-512.78	14	-118.54	6	0	2	0	2
37	N269	max		1.14	13	3918.09	10	1666.12	6	0	15	0	15
38		min		-2.25	10	-2423.54	13	-1447.45	4	0	2	0	2
39	N271	max		3.67	9	2552.54	9	101.4	4	0	15	0	15
40		min		-1.43	14	-495.12	14	-116.4	6	0	2	0	2
41	N276	max		10.77	10	3554.45	10	1897.66	6	0	15	0	15
42		min		-6.25	13	-2317.57	13	-1647.29	4	0	2	0	2
43	N278	max		9.07	12	2823.18	9	100.56	4	0	15	0	15
44		min		-23.94	11	-584.16	14	-114.12	6	0	2	0	2
45	Totals:	max		0	11	52622.62	10	16107.38	6				
46		min		0	12	-15592.26	12	-13991.45	12				

**Envelope AISC 15TH (360-16): ASD Member Steel Code Checks**

Member	Shape	Code Check	Loc[in]	LC	Shear Check	Loc[in]	Dir	LC	Pnc/om [lb]	Pnt/om [lb]	Mnny/om [lb-ft]	Mnzz/om [lb-ft]	Cb	Eqn
1	M113	PIPE2.0A21165	0.92	3.52	10	0.26	0	6	5897.81	23232.19	1397.5	1397.5	1	H1-1a
2	M131	PIPE2.0A21165	0.92	3.52	10	0.26	0	6	5897.81	23232.19	1397.5	1397.5	1	H1-1a
3	M119	PIPE2.0A21165	0.92	3.52	10	0.26	0	6	5897.81	23232.19	1397.5	1397.5	1	H1-1a
4	M125	PIPE2.0A21165	0.92	3.52	10	0.26	0	6	5897.81	23232.19	1397.5	1397.5	1	H1-1a
5	M122	PIPE2.0A21165	0.92	3.52	10	0.26	0	6	5897.81	23232.19	1397.5	1397.5	1	H1-1a
6	M116	PIPE2.0A21165	0.92	3.52	10	0.26	0	6	5897.81	23232.19	1397.5	1397.5	1	H1-1a
7	M128	PIPE2.0A21165	0.92	3.52	10	0.26	0	6	5897.81	23232.19	1397.5	1397.5	1	H1-1a
8	M149	PIPE2.0A21165	0.89	3.52	10	0.29	0	6	5897.81	23232.19	1397.5	1397.5	1	H1-1a
9	M134	PIPE2.0A21165	0.89	3.52	10	0.29	0	6	5897.81	23232.19	1397.5	1397.5	1	H1-1a
10	M72	PIPE2.5A21168	0.84	88.54	11	0.2	88.54	11	20336.2	28358.41	2081.75	2081.75	1	H1-1b
11	M71	PIPE2.5A21168	0.83	425	10	0.2	177.08	10	20336.2	28358.41	2081.75	2081.75	1	H1-1b
12	M19	1.5X1.5X0.083	0.64	67.48	10	0.03	113.66	y 10	1838.17	14085.15	624.42	624.42	1.14	H1-1a
13	M75B	1.5X1.5X0.083	0.64	67.48	10	0.03	113.66	y 10	1838.17	14085.15	624.42	624.42	1.14	H1-1a
14	M74	PIPE2.0A21165	0.57	3.52	10	0.13	0	6	5897.81	23232.19	1397.5	1397.5	1	H1-1a
15	M6	PIPE2.0A21165	0.57	3.52	10	0.13	0	6	5897.81	23232.19	1397.5	1397.5	1	H1-1a
16	M150	3x1.5x0.083	0.48	49.53	6	0.01	93.24	y 10	4894.91	21540.24	952.46	1737.71	1.14	H1-1a
17	M135	3x1.5x0.083	0.48	49.53	6	0.01	93.24	y 10	4894.91	21540.24	952.46	1737.71	1.14	H1-1a
18	M5	PIPE2.0A21165	0.44	52.4	11	0.11	52.4	6	16289.67	23232.19	1397.5	1397.5	1	H1-1b
19	M73	PIPE2.0A21165	0.44	52.4	11	0.11	52.4	6	16289.67	23232.19	1397.5	1397.5	1	H1-1b
20	M117	3x1.5x0.083	0.43	49.53	6	0	93.24	y 5	4894.91	21540.24	952.46	1737.71	1.14	H1-1a
21	M129	3x1.5x0.083	0.43	49.53	6	0	93.24	y 5	4894.91	21540.24	952.46	1737.71	1.14	H1-1a
22	M123	3x1.5x0.083	0.43	49.53	6	0	93.24	y 10	4894.91	21540.24	952.46	1737.71	1.14	H1-1a
23	M120	3x1.5x0.083	0.43	49.53	6	0	93.24	y 6	4894.91	21540.24	952.46	1737.71	1.14	H1-1a
24	M126	3x1.5x0.083	0.43	49.53	6	0	93.24	y 6	4894.91	21540.24	952.46	1737.71	1.14	H1-1a
25	M114	3x1.5x0.083	0.42	49.53	6	0.01	93.24	y 10	4894.91	21540.24	952.46	1737.71	1.14	H1-1a
26	M132	3x1.5x0.083	0.42	49.53	6	0.01	93.24	y 10	4894.91	21540.24	952.46	1737.71	1.14	H1-1a
27	M124	PIPE2.0A21165	0.4	51.81	14	0.24	52.4	6	16289.67	23232.19	1397.5	1397.5	1	H1-1b

**Envelope AISC 15TH (360-16): ASD Member Steel Code Checks (Continued)**

Member	Shape	Code Check	Loc[in]	Lc	Shear Check	Loc[in]	Dir	Lc	Pnc/om [lb]	Pnt/om [lb]	Mnyy/om [lb-ft]	Mnzz/om [lb-ft]	Cb	Eqn
28	M121	PIPE2.0A21165	0.4	51.81	14	0.24	52.4	6	16289.67	23232.19	1397.5	1397.5	1	H1-1b
29	M127	PIPE2.0A21165	0.4	51.81	14	0.24	52.4	6	16289.67	23232.19	1397.5	1397.5	1	H1-1b
30	M118	PIPE2.0A21165	0.4	51.81	14	0.24	52.4	6	16289.67	23232.19	1397.5	1397.5	1	H1-1b
31	M130	PIPE2.0A21165	0.4	51.81	14	0.24	52.4	6	16289.67	23232.19	1397.5	1397.5	1	H1-1b
32	M115	PIPE2.0A21165	0.39	51.81	14	0.23	52.4	6	16289.67	23232.19	1397.5	1397.5	1	H1-1b
33	M133	PIPE2.0A21165	0.39	51.81	14	0.23	52.4	6	16289.67	23232.19	1397.5	1397.5	1	H1-1b
34	M151	PIPE2.0A21165	0.39	51.81	14	0.27	52.4	6	16289.67	23232.19	1397.5	1397.5	1	H1-1b
35	M136	PIPE2.0A21165	0.39	51.81	14	0.27	52.4	6	16289.67	23232.19	1397.5	1397.5	1	H1-1b
36	M75	3x1.5x0.083	0.2	93.24	6	0.06	93.24	y 3	4894.91	21540.24	952.46	1737.71	1.14	H1-1b*
37	M15	3x1.5x0.083	0.2	93.24	6	0.06	93.24	y 3	4894.87	21540.24	952.46	1737.71	1.14	H1-1b*

**Envelope AA ADM1-15: ASD - BUILDING Member Aluminum Code Checks**

Member	Shape	Code Check	Loc[in]	Lc	Shear Check	Loc[in]	Dir	Lc	Pnc/Om[lb]	Pnt/Om[lb]	Mny/Om[lb-ft]	Mnz/Om[lb-ft]	Vny/Om[lb]	Vnz/Om[lb]	Cb	Eqn
1	M47	HR300/SMR300	0.9	35	11	0.11	36.75	y 11	6230.8	14342.56	533.92	934.62	7307.69	3206.15	2.32	H.1-1
2	M91	HR300/SMR300	0.9	35	11	0.11	36.75	y 11	6230.8	14342.56	533.92	934.62	7307.69	3206.15	2.32	H.1-1
3	M94	HR300/SMR300	0.9	35	11	0.1	36.75	y 11	6230.8	14342.56	533.92	934.62	7307.69	3206.15	2.32	H.1-1
4	M44	HR300/SMR300	0.9	35	11	0.1	36.75	y 11	6230.8	14342.56	533.92	934.62	7307.69	3206.15	2.32	H.1-1
5	M59	HR300/SMR300	0.9	35	11	0.1	36.75	y 11	6230.8	14342.56	533.92	934.62	7307.69	3206.15	2.32	H.1-1
6	M79	HR300/SMR300	0.9	35	11	0.1	36.75	y 11	6230.8	14342.56	533.92	934.62	7307.69	3206.15	2.32	H.1-1
7	M85	HR300/SMR300	0.9	35	11	0.1	36.75	y 11	6230.8	14342.56	533.92	934.62	7307.69	3206.15	2.32	H.1-1
8	M53	HR300/SMR300	0.9	35	11	0.1	36.75	y 11	6230.8	14342.56	533.92	934.62	7307.69	3206.15	2.32	H.1-1
9	M65	HR300/SMR300	0.9	35	11	0.1	36.75	y 11	6230.8	14342.56	533.92	934.62	7307.69	3206.15	2.32	H.1-1
10	M68	HR300/SMR300	0.9	35	11	0.1	36.75	y 11	6230.8	14342.56	533.92	934.62	7307.69	3206.15	2.32	H.1-1
11	M76	HR300/SMR300	0.9	35	11	0.1	36.75	y 11	6230.8	14342.56	533.92	934.62	7307.69	3206.15	2.32	H.1-1
12	M62	HR300/SMR300	0.9	35	11	0.1	36.75	y 11	6230.8	14342.56	533.92	934.62	7307.69	3206.15	2.32	H.1-1
13	M82	HR300/SMR300	0.9	35	11	0.1	36.75	y 11	6230.8	14342.56	533.92	934.62	7307.69	3206.15	2.32	H.1-1
14	M56	HR300/SMR300	0.9	35	11	0.1	36.75	y 11	6230.8	14342.56	533.92	934.62	7307.69	3206.15	2.32	H.1-1
15	M50	HR300/SMR300	0.9	35	11	0.1	36.75	y 11	6230.8	14342.56	533.92	934.62	7307.69	3206.15	2.32	H.1-1
16	M88	HR300/SMR300	0.9	35	11	0.1	36.75	y 11	6230.8	14342.56	533.92	934.62	7307.69	3206.15	2.32	H.1-1
17	M107	HR300/SMR300	0.89	35	11	0.11	36.75	y 11	6230.8	14342.56	533.92	934.62	7307.69	3206.15	2.32	H.1-1
18	M97	HR300/SMR300	0.89	35	11	0.11	36.75	y 11	6230.8	14342.56	533.92	934.62	7307.69	3206.15	2.32	H.1-1
19	M100	HR300/SMR300	0.86	82.25	10	0.12	36.75	y 11	3914.17	14342.56	533.92	934.62	7307.69	3206.15	1.45	H.1-1
20	M101	HR300/SMR300	0.86	82.25	10	0.12	36.75	y 11	3914.17	14342.56	533.92	934.62	7307.69	3206.15	1.45	H.1-1



JOB NO.: U2716.0386.241

PROJECT: SunTurf Package A17

SUBJECT: SP - 35 Degrees

DESIGN APPROACH ASD

CONNECTION CAPACITY

Location: Column Base (set screws)

Connection Type: M16 Conical Set Screws

Tensile Capacity: 2600 lbs

Tension Load: 2427 lbs

Check Connection: 93.3%

Result: **Select M16 Conical Set Screws**

Note: Uplift capacity. FOS of (2)

CONNECTION CAPACITY

Location: Column to Cross Beam

Connection Type: K10341-002

Tensile Capacity: 2195 lbs

Tension Load: 1698 lbs

Check Connection: 77.4%

Result: **Select K10341-002**

Note: Uplift capacity. FOS of (2)



JOB NO.: U2716.0386.241

PROJECT: SunTurf Package A17

SUBJECT: SP - 35 Degrees

**CONNECTION CAPACITY**

Location: Brace to Column

Connection Type: K10219-001

Capacity: 3125 lbs

Tension Load: 2296 lbs

Check Connection: 73.5%

Result: **Select K10219-001**

Note: Axial capacity - double braces. FOS of (2)

**BOLTED TENSION CONNECTION**

Location: Rail to Cross Beam

Bolt Grade: A304 SS (A2-70)

Bolt Diameter: 0.375 in

Number of Bolts: 2

Bolt Capacity: 8410 lbs (AISC Equation J3-1)

Tension Load: 941 lbs

Check Bolt: 11.2%

Result: **Select (2) 0.375 in. dia. A304 SS (A2-70) bolts.**

Note:

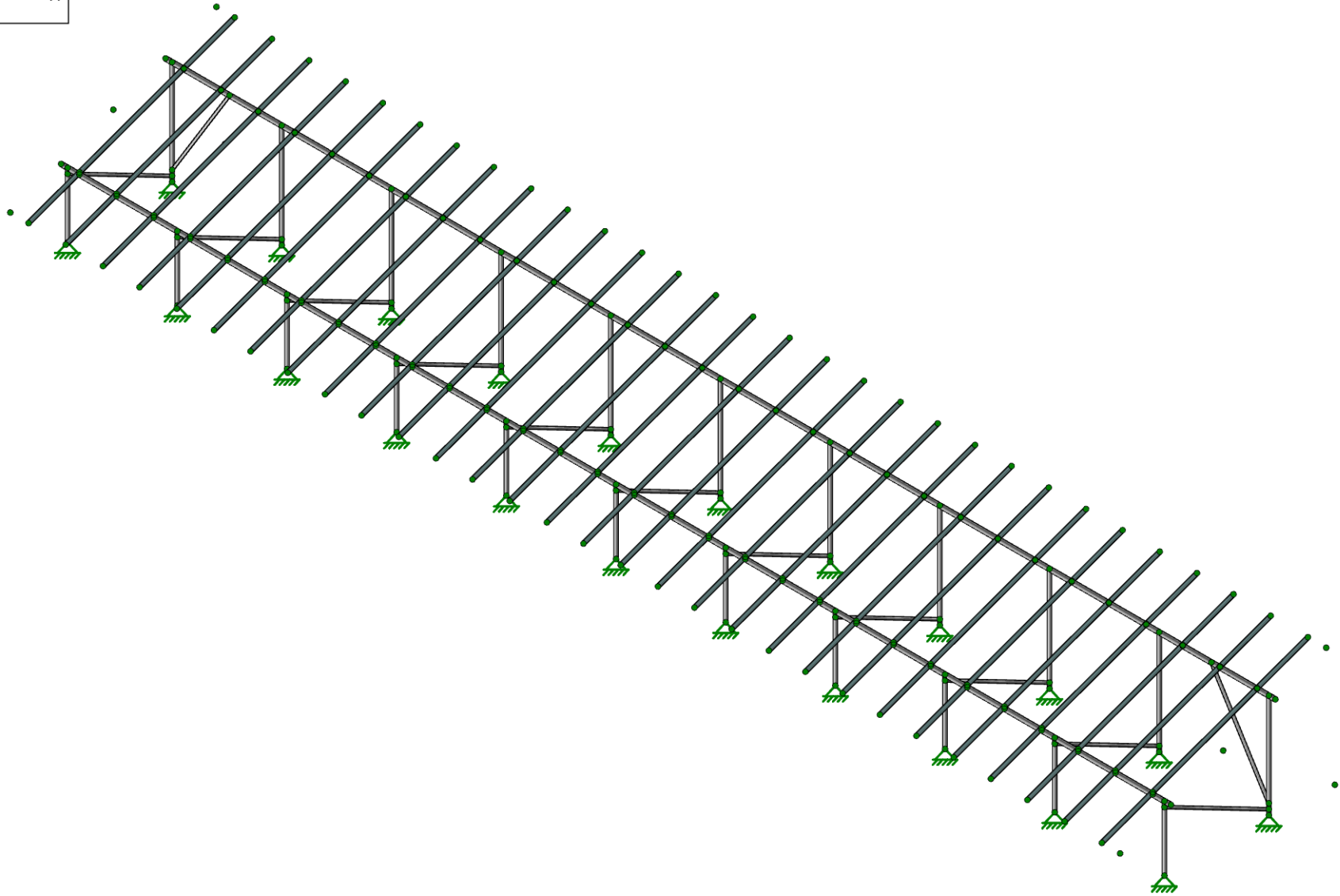
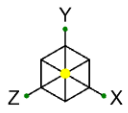

Vector Structural Engineering  
MIH  
U2716.0386.241

A17 Standard Panels - 20 Degree Tilt

SK-1  
Mar 25, 2024 at 03:40 PM  
Sunturf A17 - SP - 20deg.r3d

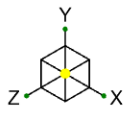

- Section Sets
- █ Post
  - █ Cross Beam
  - █ Diagonal Brace
  - █ RIGID
  - █ AL Rails

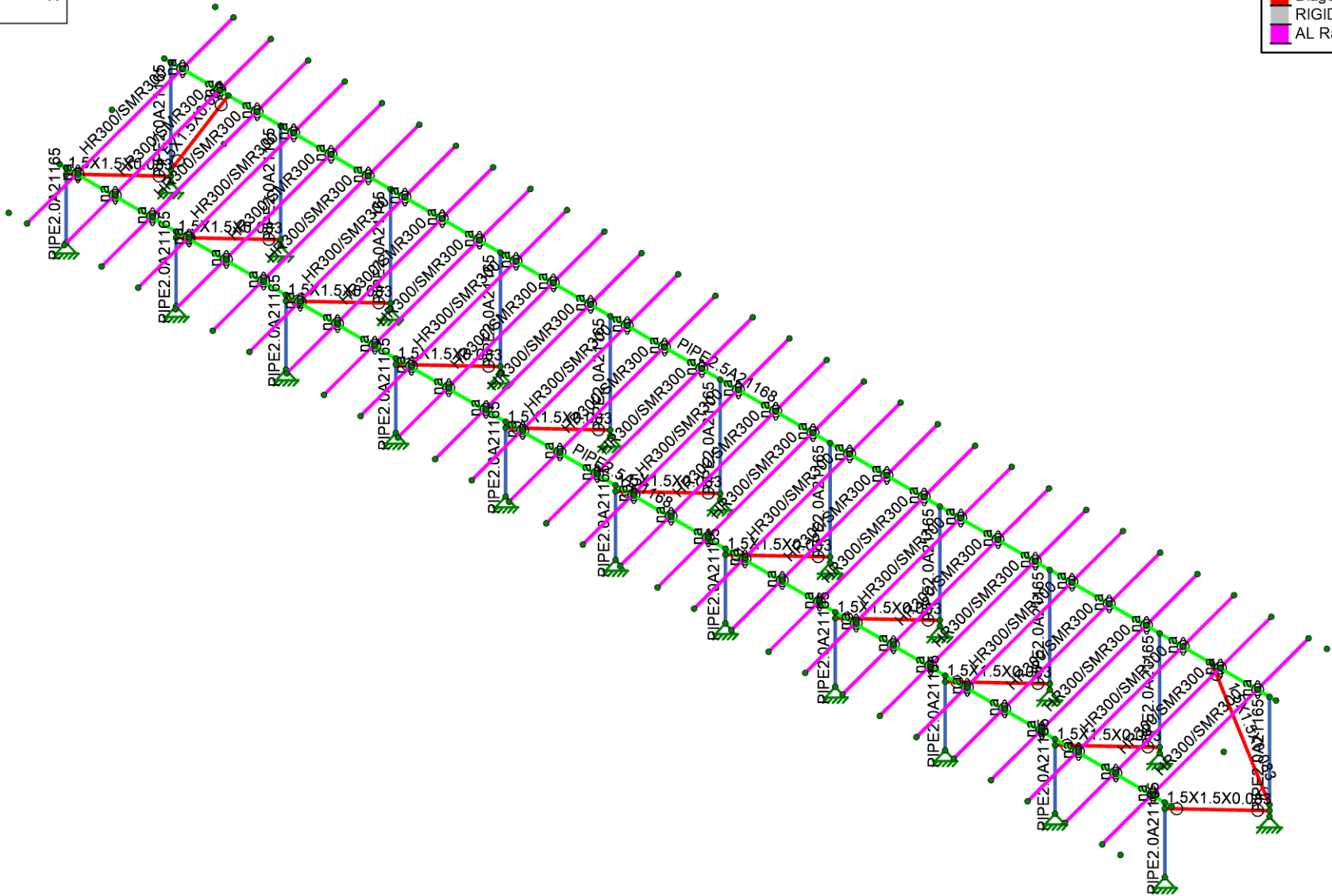

Vector Structural Engineering  
 MIH  
 U2716.0386.241

A17 Standard Panels - 20 Degree Tilt

SK-2  
 Mar 25, 2024 at 03:41 PM  
 Sunturf A17 - SP - 20deg.r3d

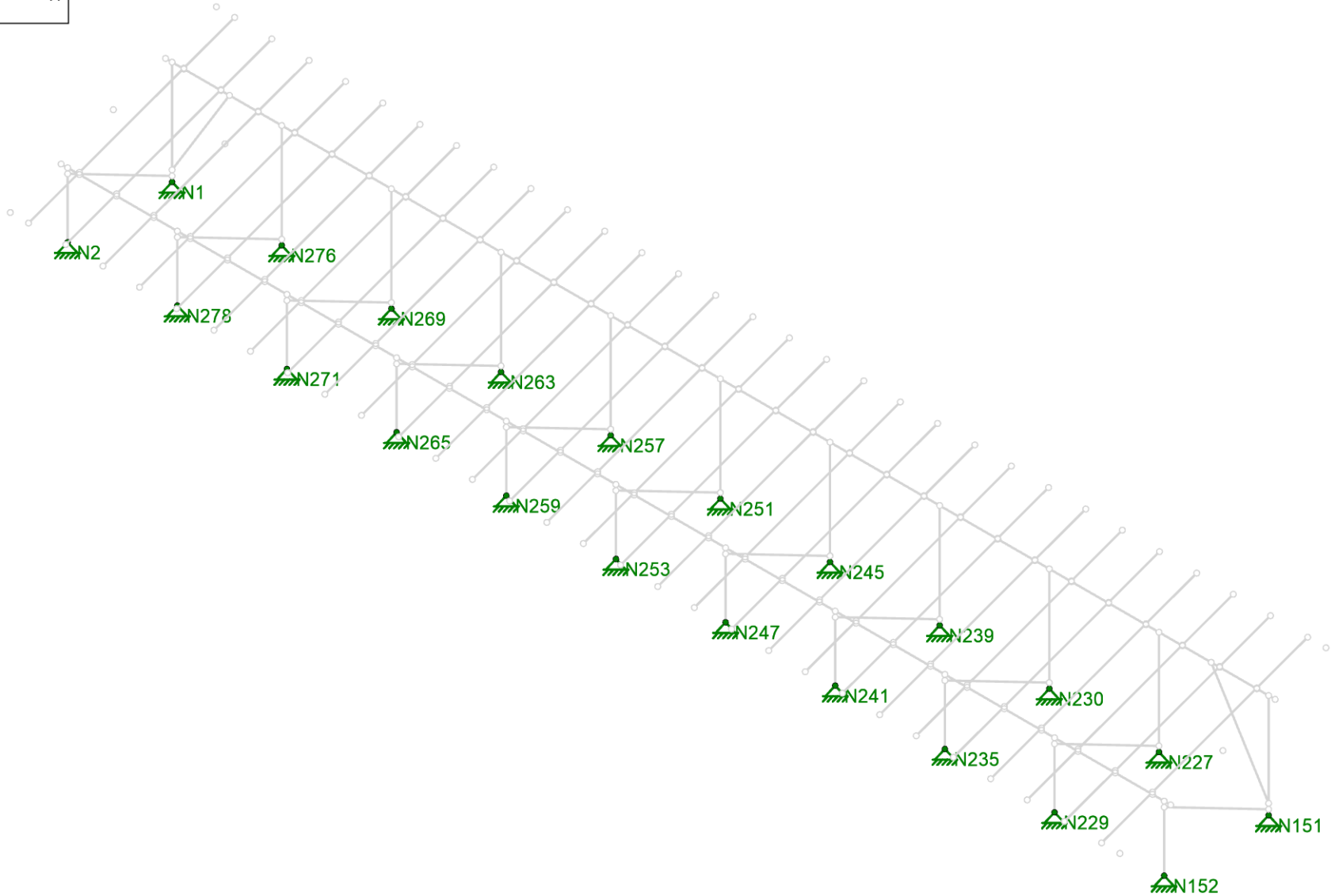
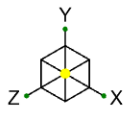

Vector Structural Engineering
MIH
U2716.0386.241

A17 Standard Panels - 20 Degree Tilt

SK-3
Mar 25, 2024 at 03:42 PM
Sunturf A17 - SP - 20deg.r3d

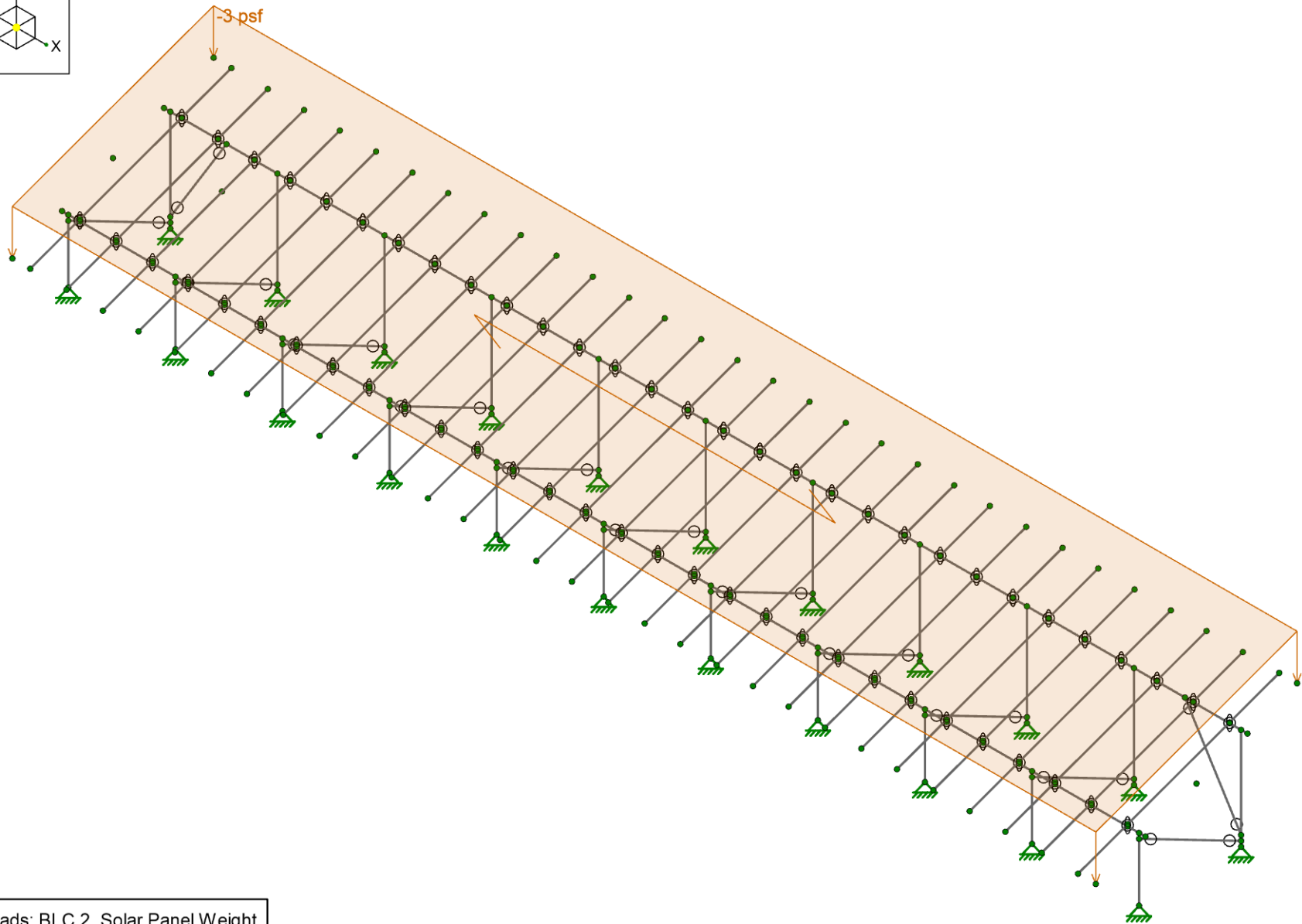
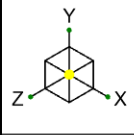

Loads: BLC 2, Solar Panel Weight



Vector Structural Engineering

MIH

U2716.0386.241

A17 Standard Panels - 20 Degree Tilt

SK-4

Mar 25, 2024 at 03:42 PM

Sunturf A17 - SP - 20deg.r3d



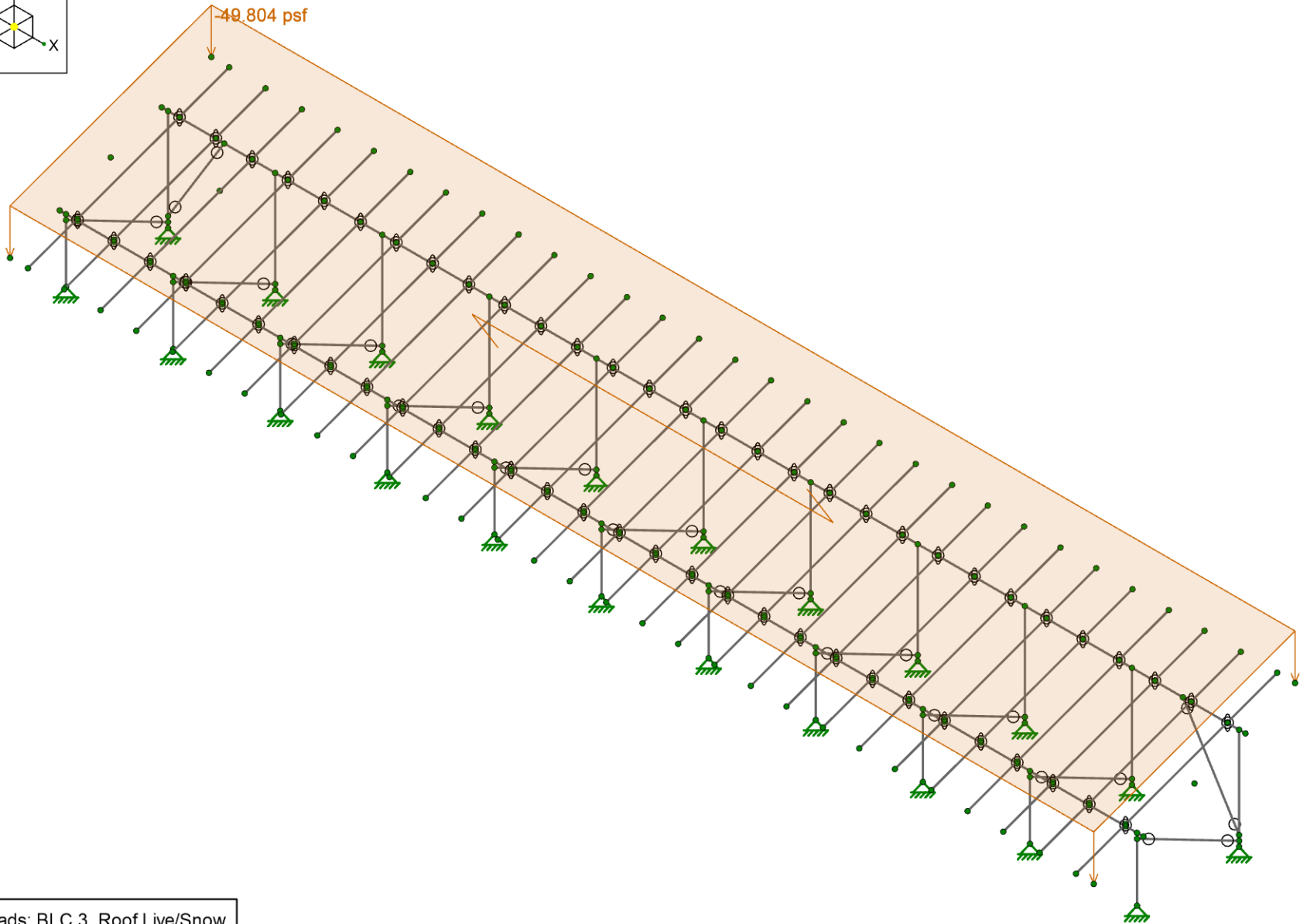
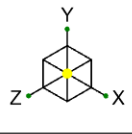

Loads: BLC 3, Roof Live/Snow



Vector Structural Engineering

MIH

U2716.0386.241

A17 Standard Panels - 20 Degree Tilt

SK-5

Mar 25, 2024 at 03:43 PM

Sunturf A17 - SP - 20deg.r3d

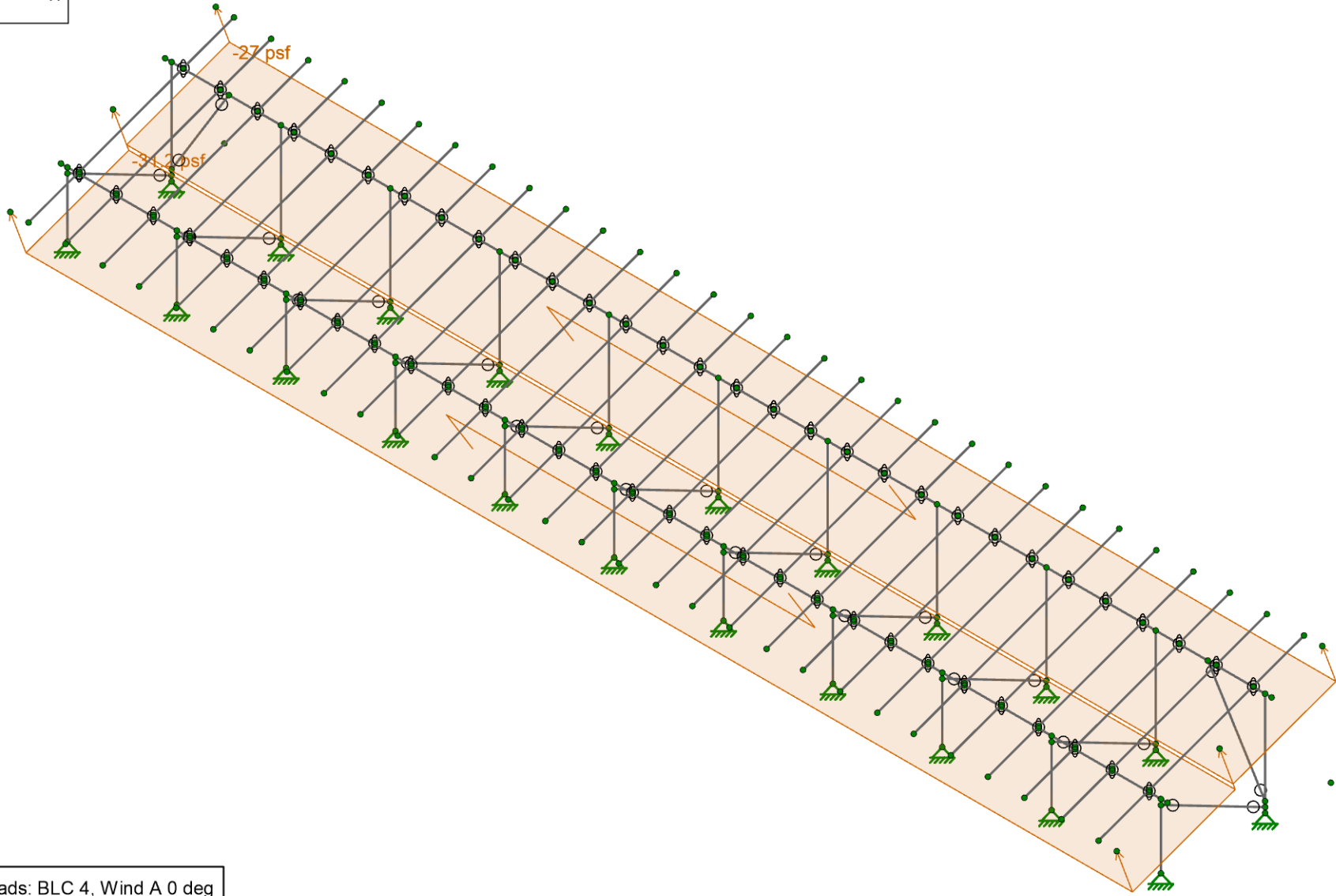
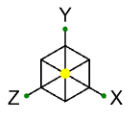

Loads: BLC 4, Wind A 0 deg

 IRISA A NEMETSCHKE COMPANY	Vector Structural Engineering	A17 Standard Panels - 20 Degree Tilt	SK-6
	MIH		Mar 25, 2024 at 03:43 PM
	U2716.0386.241		Sunturf A17 - SP - 20deg.r3d

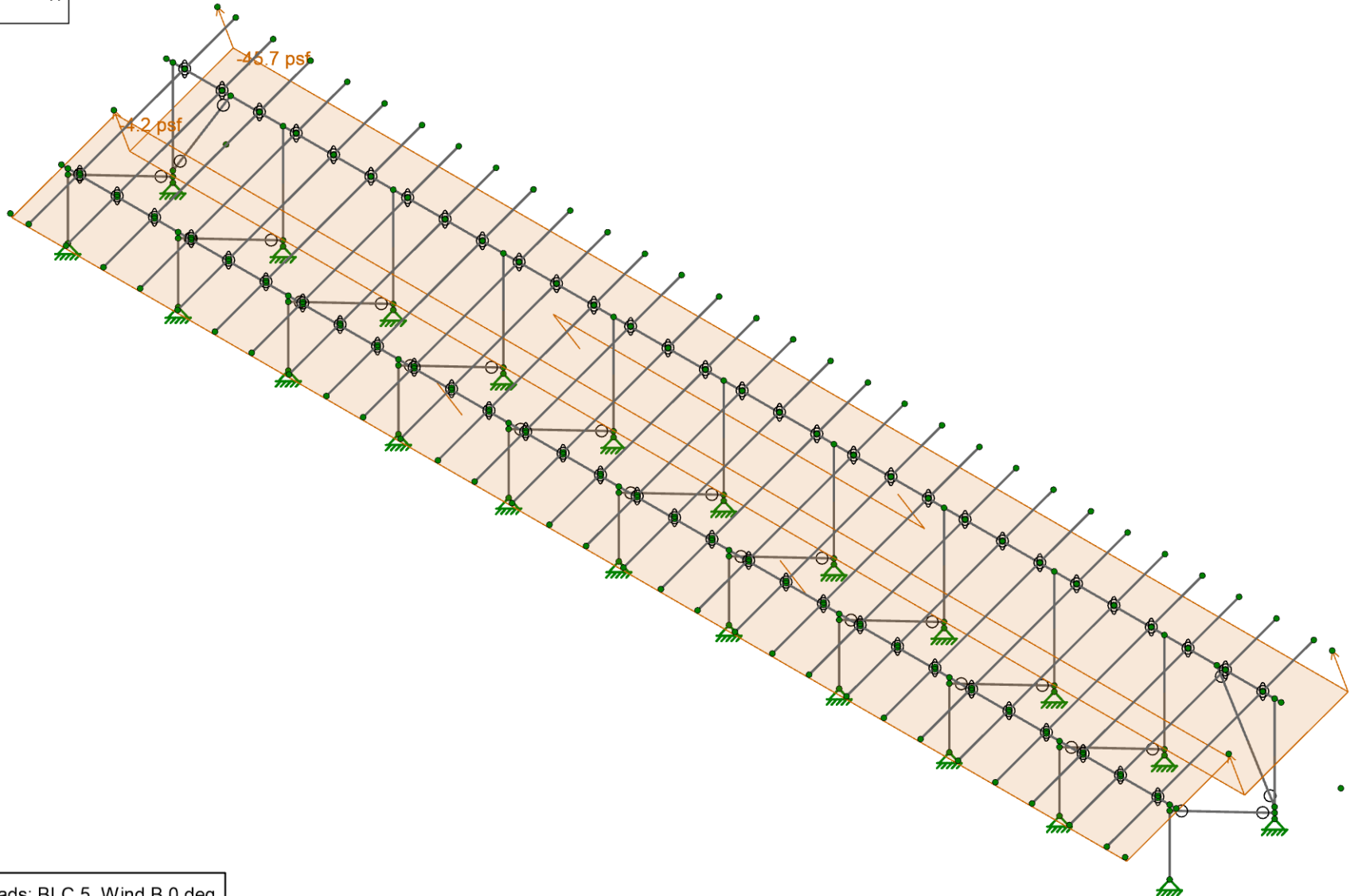
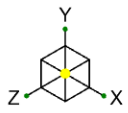

Loads: BLC 5, Wind B 0 deg

 A NEMETSCHKE COMPANY	Vector Structural Engineering	A17 Standard Panels - 20 Degree Tilt	SK-7
	MIH		Mar 25, 2024 at 03:43 PM
	U2716.0386.241		Sunturf A17 - SP - 20deg.r3d

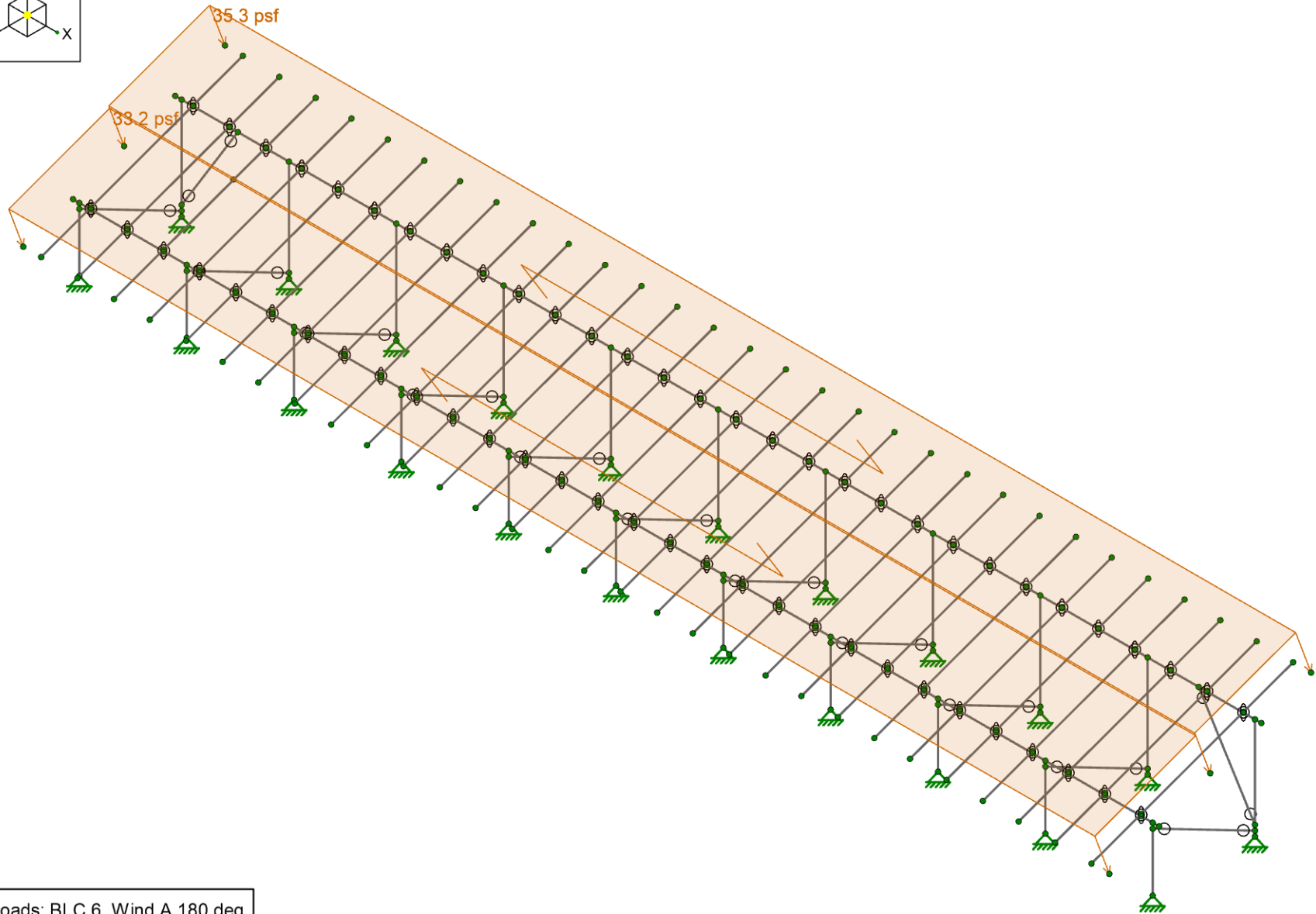
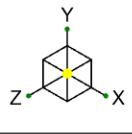

Loads: BLC 6, Wind A 180 deg



Vector Structural Engineering  
MIH  
U2716.0386.241

A17 Standard Panels - 20 Degree Tilt

SK-8  
Mar 25, 2024 at 03:44 PM  
Sunturf A17 - SP - 20deg.r3d

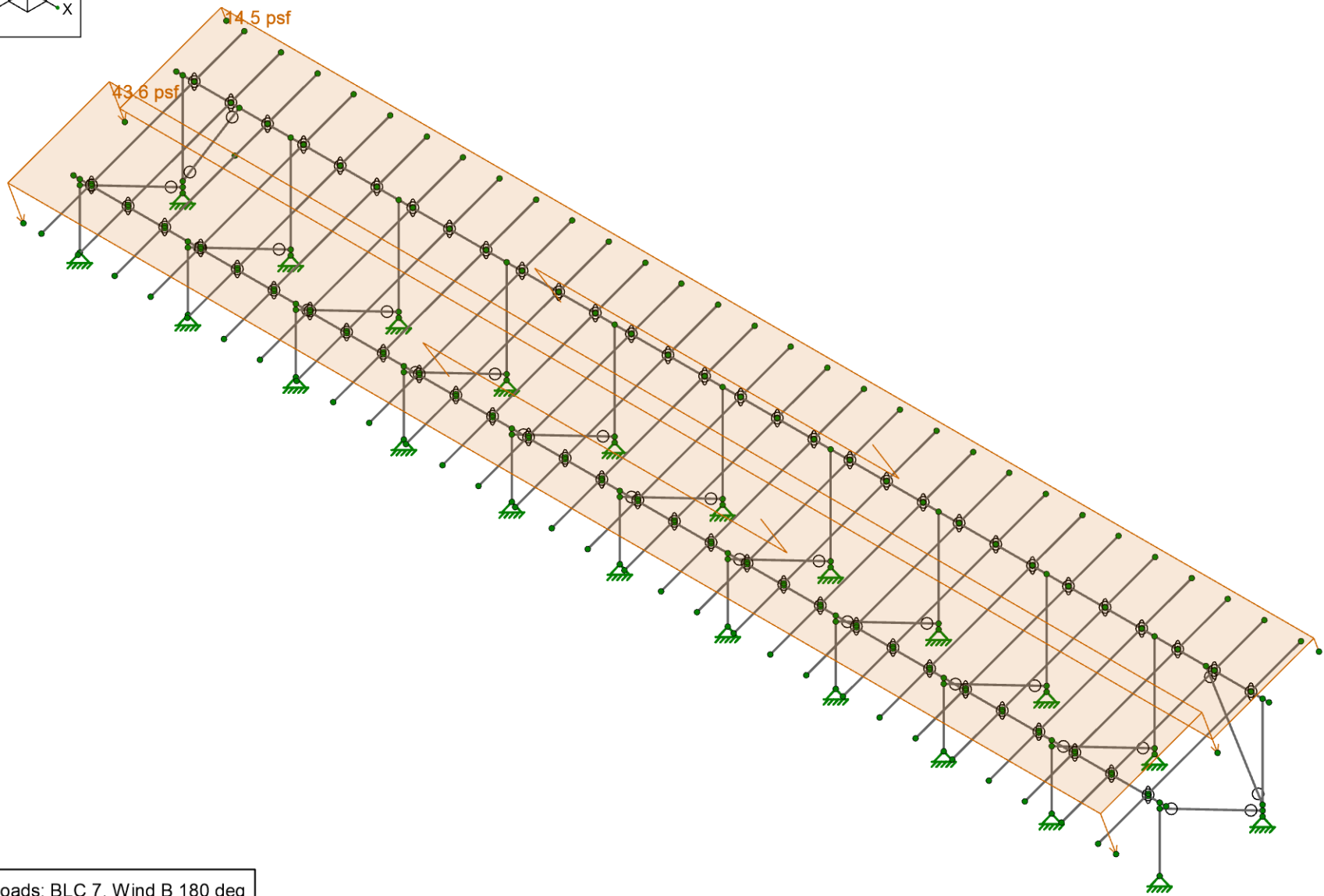
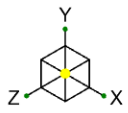

Loads: BLC 7, Wind B 180 deg



Vector Structural Engineering

MIH

U2716.0386.241

A17 Standard Panels - 20 Degree Tilt

SK-9

Mar 25, 2024 at 03:44 PM

Sunturf A17 - SP - 20deg.r3d

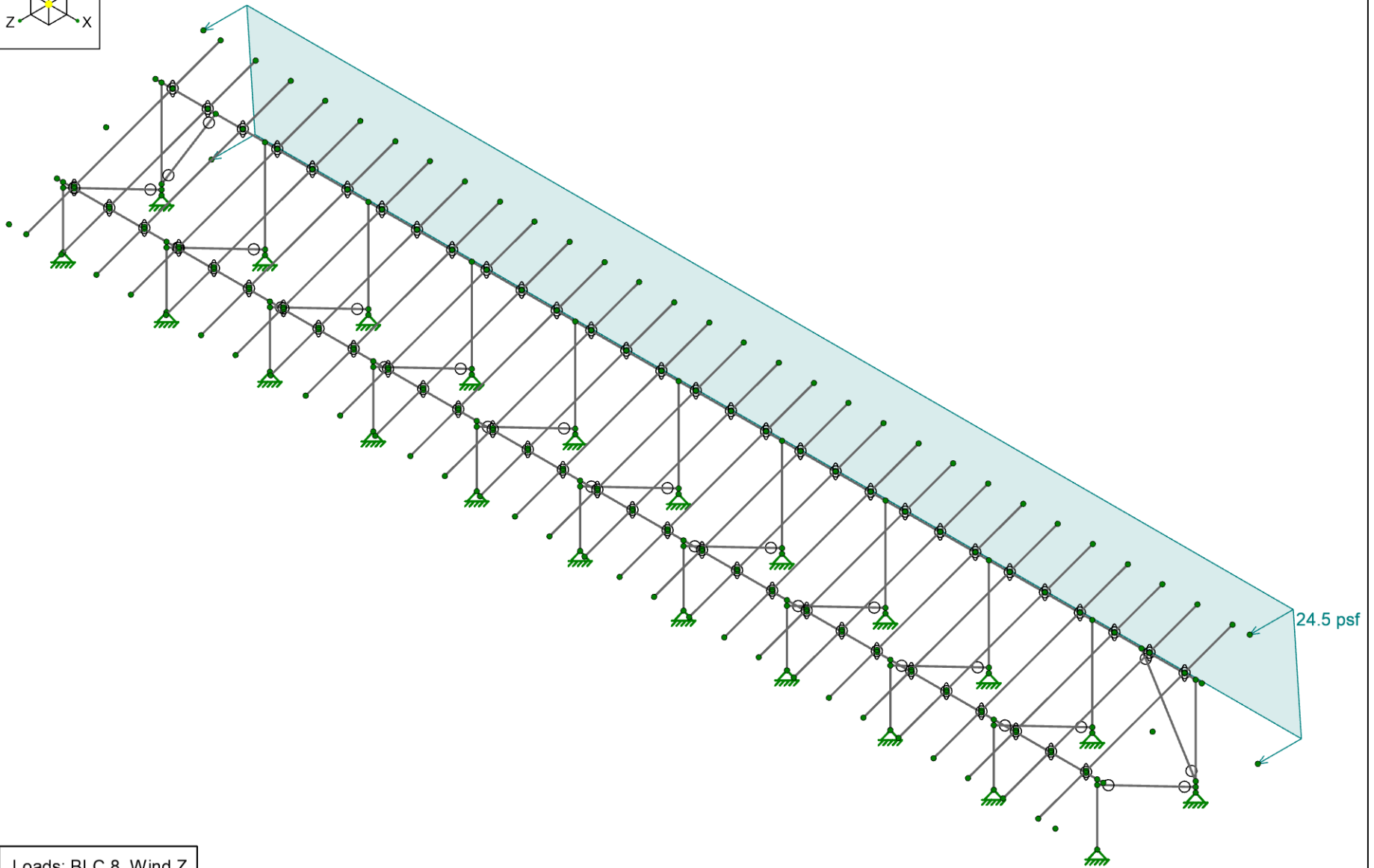
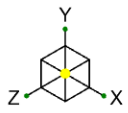

Loads: BLC 8, Wind Z



Vector Structural Engineering

MIH

U2716.0386.241

A17 Standard Panels - 20 Degree Tilt

SK-10

Mar 25, 2024 at 03:49 PM

Sunturf A17 - SP - 20deg.r3d

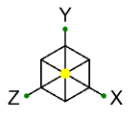

Code Check (Env)	
Black	No Calc
Red	> 1.0
Magenta	.90-1.0
Green	.75-90
Cyan	.50-.75
Blue	0-.50

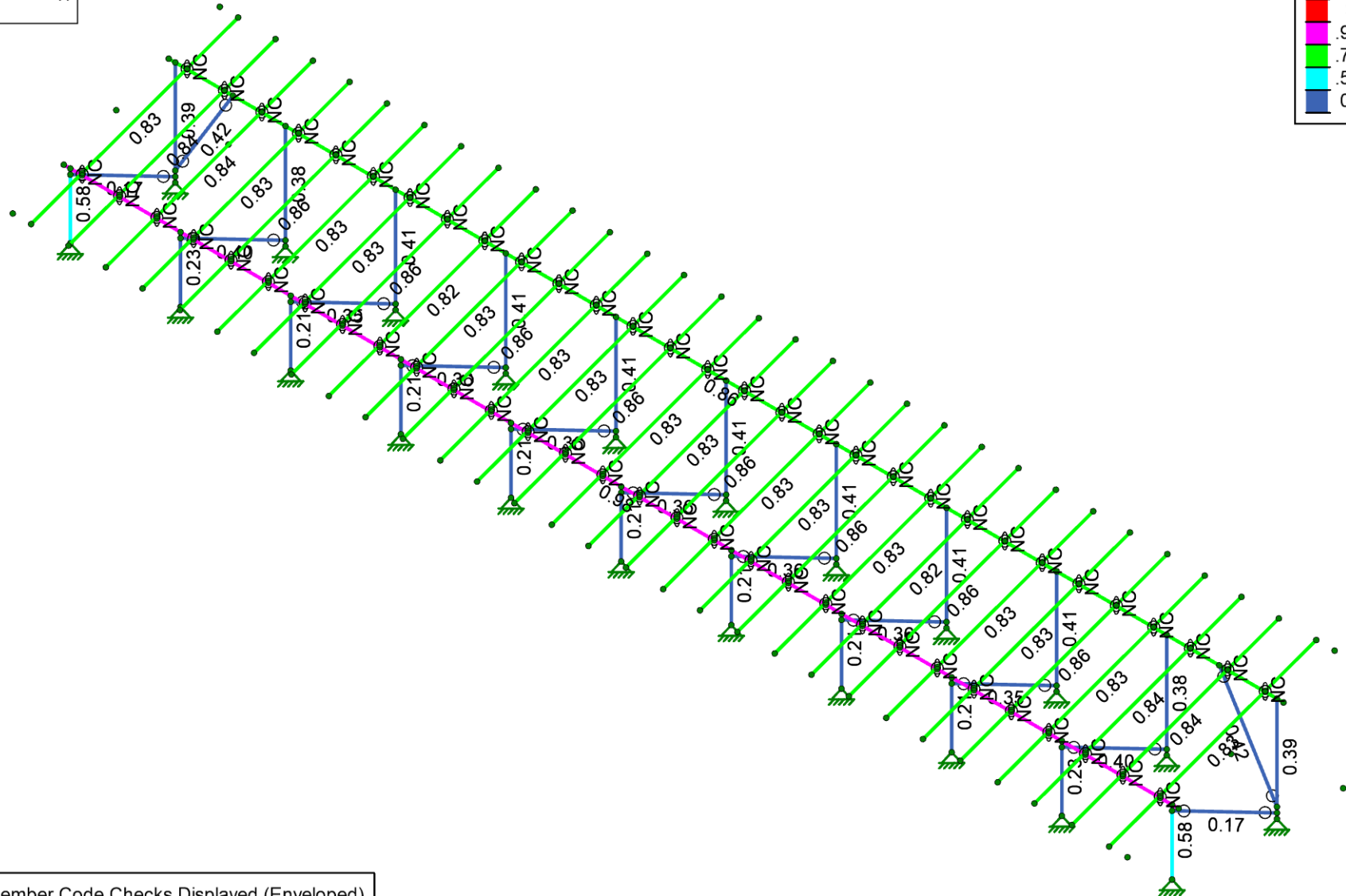

Member Code Checks Displayed (Enveloped)

	Vector Structural Engineering	A17 Standard Panels - 20 Degree Tilt	SK-11
	MIH		Mar 25, 2024 at 03:50 PM
	U2716.0386.241		Sunturf A17 - SP - 20deg.r3d

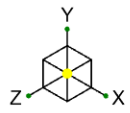

Shear Check (Env)

- No Calc
- > 1.0
- .90-1.0
- .75-.90
- .50-.75
- 0-.50

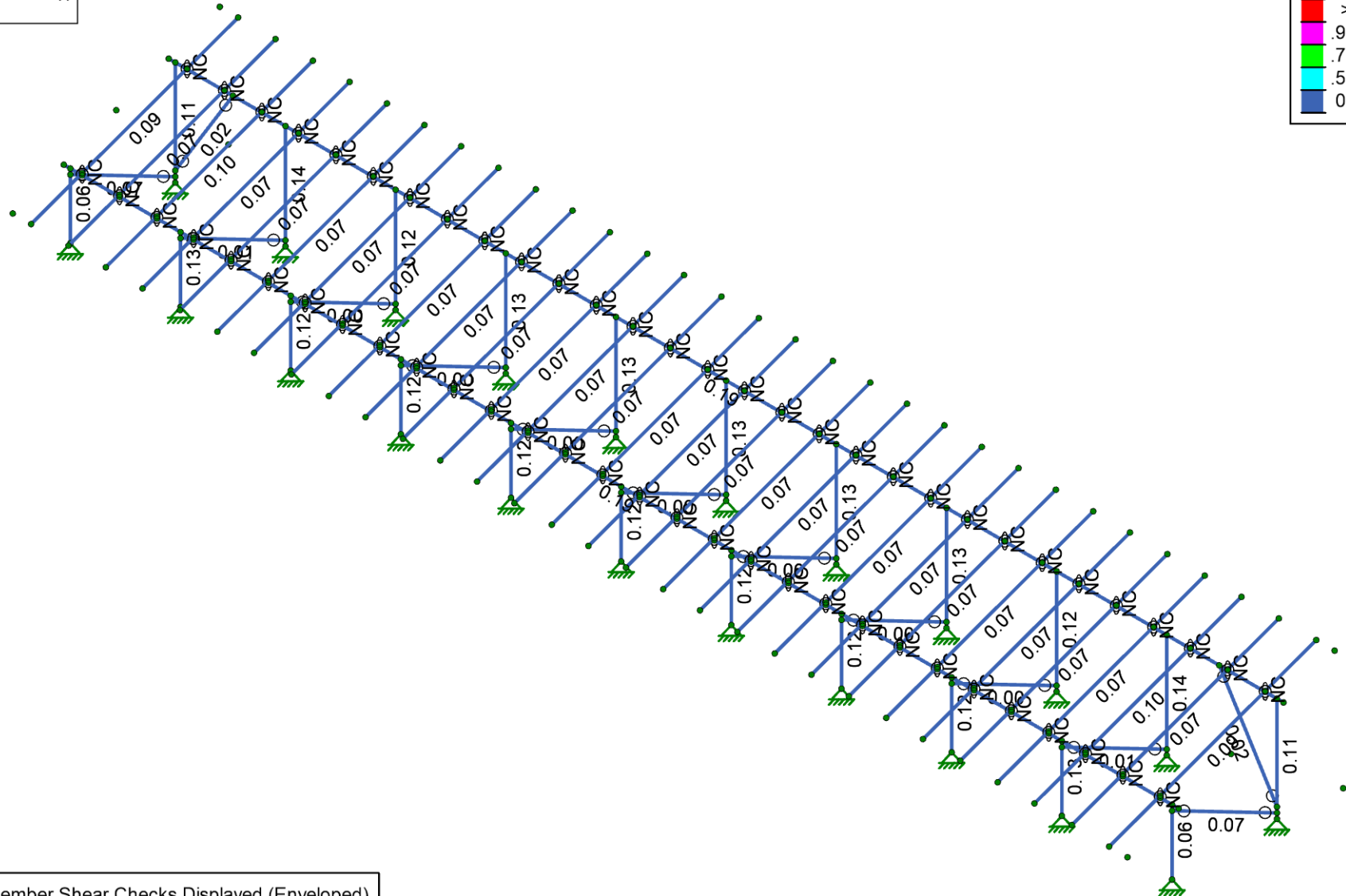

Member Shear Checks Displayed (Enveloped)

 <small>A NEMETSCHek COMPANY</small>	Vector Structural Engineering	A17 Standard Panels - 20 Degree Tilt	SK-12
	MIH		Mar 25, 2024 at 03:51 PM
	U2716.0386.241		Sunturf A17 - SP - 20deg.r3d



**Hot Rolled Steel Properties**

	Label	E [ksi]	G [ksi]	Nu	Therm. Coeff. [1e <sup>6</sup> F <sup>-1</sup> ]	Density [lb/ft <sup>3</sup> ]	Yield [psi]	Ry	Fu [psi]	Rt
1	A992	29000	11154	0.3	0.65	490	50000	1.1	65000	1.1
2	A36 Gr.36	29000	11154	0.3	0.65	490	36000	1.5	58000	1.2
3	A572 Gr.50	29000	11154	0.3	0.65	490	50000	1.1	65000	1.1
4	A500 Gr.B RND	29000	11154	0.3	0.65	527	42000	1.4	58000	1.3
5	A500 Gr.B Rect	29000	11154	0.3	0.65	527	46000	1.4	58000	1.3
6	A53 Gr.B	29000	11154	0.3	0.65	490	35000	1.6	60000	1.2
7	A1085	29000	11154	0.3	0.65	490	50000	1.4	65000	1.3

**Aluminum Properties**

	Label	E [ksi]	G [ksi]	Nu	Therm. Coeff. [1e <sup>6</sup> F <sup>-1</sup> ]	Density [lb/ft <sup>3</sup> ]	Table B.4	kt	Ftu [psi]	Fty [psi]	Fcy [psi]	Fsu [psi]	Ct
1	3003-H14	10100	3787.5	0.33	1.3	172.8	Table B.4-1	1	19000	16000	13000	12000	141
2	6061-T6	10100	3787.5	0.33	1.3	172.8	Table B.4-2	1	38000	35000	35000	24000	141
3	6063-T5	10100	3787.5	0.33	1.3	172.8	Table B.4-2	1	22000	16000	16000	13000	141
4	6063-T6	10100	3787.5	0.33	1.3	172.8	Table B.4-2	1	30000	25000	25000	19000	141
5	5052-H34	10200	3787.5	0.33	1.3	172.8	Table B.4-1	1	34000	26000	24000	20000	141
6	6061-T6 W	10100	3787.5	0.33	1.3	172.8	Table B.4-1	1	24000	15000	15000	15000	141
7	6005-T5	10100	3787.5	0.33	1.3	172.8	Table B.4-1	1	38000	35000	35000	24000	141

**Hot Rolled Steel Section Sets**

	Label	Shape	Type	Design List	Material	Design Rule	Area [in <sup>2</sup> ]	Iyy [in <sup>4</sup> ]	Izz [in <sup>4</sup> ]	J [in <sup>4</sup> ]
1	Post	PIPE2.0A21165	Column	Pipe	A572 Gr.50	Typical	0.776	0.499	0.499	0.998
2	Cross Beam	PIPE2.5A21168	Beam	Wide Flange	A572 Gr.50	Typical	0.947	0.907	0.907	1.814
3	Diagonal Brace	1.5X1.5X0.083	HBrace	SquareTube	A572 Gr.50	Typical	0.47	0.158	0.158	0.236

**Aluminum Section Sets**

	Label	Shape	Type	Design List	Material	Design Rule	Area [in <sup>2</sup> ]	Iyy [in <sup>4</sup> ]	Izz [in <sup>4</sup> ]	J [in <sup>4</sup> ]
1	AL Posts	2.375ODX0.188	Column	Pipe	6005-T5	Typical	1.29	0.778	0.778	1.54
2	AL Brace	RT1.5X2X0.15625	VBrace	Rectangular Tubes	6005-T5	Typical	0.996	0.327	0.524	0.602
3	AL Rails	HR300/SMR300	Beam	Rectangular Tubes	6005-T5	Typical	0.736	0.214	0.727	0.734
4	AL Cross Beam	CROSSRAIL	Beam	Rectangular Tubes	6005-T5	Typical	1.909	1.97	4.366	4.017

**Basic Load Cases**

	BLC Description	Category	Y Gravity	Distributed	Area(Member)
1	Self Weight	DL	-1.05		
2	Solar Panel Weight	DL			1
3	Roof Live/Snow	RLL			1
4	Wind A 0 deg	OL1			2
5	Wind B 0 deg	OL2			2
6	Wind A 180 deg	OL3			2
7	Wind B 180 deg	OL4			2
8	Wind Z	WLZ			1
9	BLC 2 Transient Area Loads	None		50	
10	BLC 3 Transient Area Loads	None		50	
11	BLC 4 Transient Area Loads	None		200	
12	BLC 5 Transient Area Loads	None		200	
13	BLC 6 Transient Area Loads	None		200	
14	BLC 7 Transient Area Loads	None		200	
15	BLC 8 Transient Area Loads	None		114	

**Load Combinations**

	Description	Solve	P-Delta	BLC	Factor	BLC	Factor	BLC	Factor	BLC	Factor
1	ASD Loads		Y								
2	1.0 D	Yes	Y	DL	1						
3	1.0 D + 1.0 S	Yes	Y	DL	1	RLL	1				
4	1.0 D + 0.6 W1	Yes	Y	DL	1	RLL		OL1	0.6	WLZ	0.6
5	1.0 D + 0.6 W2	Yes	Y	DL	1	RLL		OL2	0.6	WLZ	0.6
6	1.0 D + 0.6 W3	Yes	Y	DL	1	RLL		OL3	0.6	WLZ	-0.6
7	1.0 D + 0.6 W4	Yes	Y	DL	1	RLL		OL4	0.6	WLZ	-0.6
8	1.0 D + 0.45 W1 + 0.75 S	Yes	Y	DL	1	RLL	0.75	OL1	0.45	WLZ	0.45
9	1.0 D + 0.45 W2 + 0.75 S	Yes	Y	DL	1	RLL	0.75	OL2	0.45	WLZ	0.45
10	1.0 D + 0.45 W3 + 0.75 S	Yes	Y	DL	1	RLL	0.75	OL3	0.45	WLZ	-0.45
11	1.0 D + 0.45 W4 + 0.75 S	Yes	Y	DL	1	RLL	0.75	OL4	0.45	WLZ	-0.45
12	0.6 D + 0.6 W1	Yes	Y	DL	0.6	RLL		OL1	0.6	WLZ	0.6
13	0.6 D + 0.6 W2	Yes	Y	DL	0.6	RLL		OL2	0.6	WLZ	0.6
14	0.6 D + 0.6 W3	Yes	Y	DL	0.6	RLL		OL3	0.6	WLZ	-0.6
15	0.6 D + 0.6 W4	Yes	Y	DL	0.6	RLL		OL4	0.6	WLZ	-0.6
16			Y								
17	LRFD Loads		Y								
18	1.4 D		Y	DL	1.4	RLL					
19	1.2 D + 1.6 S + 0.5 W1		Y	DL	1.2	RLL	1.6	OL1	0.5		
20	1.2 D + 1.6 S + 0.5 W2		Y	DL	1.2	RLL	1.6	OL2	0.5		
21	1.2 D + 1.6 S + 0.5 W3		Y	DL	1.2	RLL	1.6	OL3	0.5		
22	1.2 D + 1.6 S + 0.5 W4		Y	DL	1.2	RLL	1.6	OL4	0.5		
23	1.2 D + 1.0 W1		Y	DL	1.2	RLL		OL1	1		
24	1.2 D + 1.0 W2		Y	DL	1.2	RLL		OL2	1		
25	1.2 D + 1.0 W3		Y	DL	1.2	RLL		OL3	1		
26	1.2 D + 1.0 W4		Y	DL	1.2	RLL		OL4	1		
27	0.9 D + 1.0 W1		Y	DL	0.9	RLL		OL1	1		
28	0.9 D + 1.0 W2		Y	DL	0.9	RLL		OL2	1		
29	0.9 D + 1.0 W3		Y	DL	0.9	RLL		OL3	1		
30	0.9 D + 1.0 W4		Y	DL	0.9	RLL		OL4	1		

**Envelope Node Reactions**

Node Label	X [lb]	LC	Y [lb]	LC	Z [lb]	LC	MX [lb-ft]	LC	MY [lb-ft]	LC	MZ [lb-ft]	LC
1 N2 max	176.62	11	1312.66	3	32.52	4	0	15	0	15	0	15
2 min	-41.17	12	-97.78	12	-39.43	6	0	2	0	2	0	2
3 N1 max	665.1	10	2255.45	10	417.78	14	0	15	0	15	0	15
4 min	-277.3	13	-1081.43	13	-364.41	4	0	2	0	2	0	2
5 N151 max	277.3	13	2255.39	10	417.79	14	0	15	0	15	0	15
6 min	-665.1	10	-1081.42	13	-364.41	4	0	2	0	2	0	2
7 N152 max	41.17	12	1312.69	3	32.52	4	0	15	0	15	0	15
8 min	-176.61	11	-97.78	12	-39.43	6	0	2	0	2	0	2
9 N230 max	3.88	10	3328.48	10	841.25	6	0	15	0	15	0	15
10 min	-1.79	13	-1701.35	13	-729.29	4	0	2	0	2	0	2
11 N235 max	1.4	12	2600.66	3	55.05	4	0	15	0	15	0	15
12 min	-7.18	11	-195.39	12	-66.84	6	0	2	0	2	0	2
13 N239 max	0.55	13	3256.93	10	866.37	6	0	15	0	15	0	15
14 min	-1.56	10	-1679.1	13	-749.91	4	0	2	0	2	0	2
15 N241 max	0.46	6	2645.46	3	56.08	4	0	15	0	15	0	15
16 min	-0.36	12	-193.61	12	-68.15	6	0	2	0	2	0	2
17 N245 max	0.08	9	3271.91	10	861.63	6	0	15	0	15	0	15
18 min	-0.08	10	-1683.95	13	-746.18	4	0	2	0	2	0	2
19 N247 max	0.02	12	2637.61	3	56.14	4	0	15	0	15	0	15
20 min	-0.63	3	-193.92	12	-68.22	6	0	2	0	2	0	2
21 N251 max	0	3	3268.16	10	862.8	6	0	15	0	15	0	15

**Envelope Node Reactions (Continued)**

Node Label		X [lb]	LC	Y [lb]	LC	Z [lb]	LC	MX [lb-ft]	LC	MY [lb-ft]	LC	MZ [lb-ft]	LC	
22		min	0	13	-1682.69	13	-747.07	4	0	2	0	2	0	2
23	N253	max	0	3	2639.22	3	56.19	4	0	15	0	15	0	15
24		min	0	14	-193.88	12	-68.27	6	0	2	0	2	0	2
25	N257	max	0.08	10	3271.85	10	861.64	6	0	15	0	15	0	15
26		min	-0.08	9	-1683.92	13	-746.19	4	0	2	0	2	0	2
27	N259	max	0.62	3	2637.61	3	56.15	4	0	15	0	15	0	15
28		min	-0.02	12	-193.91	12	-68.22	6	0	2	0	2	0	2
29	N263	max	1.56	10	3256.95	10	866.4	6	0	15	0	15	0	15
30		min	-0.55	13	-1679.13	13	-749.93	4	0	2	0	2	0	2
31	N265	max	0.36	12	2645.47	3	56.08	4	0	15	0	15	0	15
32		min	-0.46	6	-193.59	12	-68.15	6	0	2	0	2	0	2
33	N269	max	1.79	13	3328.37	10	841.26	6	0	15	0	15	0	15
34		min	-3.88	10	-1701.31	13	-729.3	4	0	2	0	2	0	2
35	N271	max	7.18	11	2600.66	3	55.05	4	0	15	0	15	0	15
36		min	-1.4	12	-195.38	12	-66.84	6	0	2	0	2	0	2
37	N276	max	23.15	10	2817.54	10	957.04	6	0	15	0	15	0	15
38		min	-9.87	13	-1525.8	13	-827.42	4	0	2	0	2	0	2
39	N278	max	8.02	12	2848.43	3	54.61	4	0	15	0	15	0	15
40		min	-30.09	11	-194.11	12	-66.45	6	0	2	0	2	0	2
41	N227	max	9.87	13	2817.7	10	957	6	0	15	0	15	0	15
42		min	-23.15	10	-1525.81	13	-827.38	4	0	2	0	2	0	2
43	N229	max	30.08	11	2848.33	3	54.6	4	0	15	0	15	0	15
44		min	-8.02	12	-194.13	12	-66.45	6	0	2	0	2	0	2
45	Totals:	max	0	11	55737.14	10	8064.53	14						
46		min	0	12	-13670.06	12	-7016.47	4						

**Envelope AISC 15TH (360-16): ASD Member Steel Code Checks**

Member	Shape	Code Check	Loc[in]	LC	Shear	Check	Loc[in]	Dir	LC	Pnc/om [lb]	Pnt/om [lb]	Mnny/om [lb-ft]	Mnzz/om [lb-ft]	Cb	Eqn
1	M72	PIPE2.5A21168	0.98	88.54	11	0.19	88.54	11	20336.2	28358.41	2081.75	2081.75	1	H1-1b	
2	M71	PIPE2.5A21168	0.86	425	10	0.19	672.92	10	20336.2	28358.41	2081.75	2081.75	1	H1-1b	
3	M5	PIPE2.0A21165	0.58	49.41	11	0.06	45.81	6	17602.61	23232.19	1397.5	1397.5	1	H1-1b	
4	M73	PIPE2.0A21165	0.58	49.41	11	0.06	45.81	6	17602.61	23232.19	1397.5	1397.5	1	H1-1b	
5	M75B	1.5X1.5X0.083	0.42	46.31	10	0.02	83.88	y 11	3374.63	14085.15	624.42	624.42	1.14	H1-1a	
6	M19	1.5X1.5X0.083	0.42	46.31	10	0.02	83.88	y 11	3374.63	14085.15	624.42	624.42	1.14	H1-1a	
7	M113	PIPE2.0A21165	0.41	3.31	10	0.12	0	6	11344.58	23232.19	1397.5	1397.5	1	H1-1a	
8	M131	PIPE2.0A21165	0.41	3.31	10	0.12	0	6	11344.58	23232.19	1397.5	1397.5	1	H1-1a	
9	M119	PIPE2.0A21165	0.41	3.31	10	0.13	0	6	11344.58	23232.19	1397.5	1397.5	1	H1-1a	
10	M125	PIPE2.0A21165	0.41	3.31	10	0.13	0	6	11344.58	23232.19	1397.5	1397.5	1	H1-1a	
11	M122	PIPE2.0A21165	0.41	3.31	10	0.13	0	6	11344.58	23232.19	1397.5	1397.5	1	H1-1a	
12	M128	PIPE2.0A21165	0.41	3.31	10	0.13	0	6	11344.58	23232.19	1397.5	1397.5	1	H1-1a	
13	M116	PIPE2.0A21165	0.41	3.31	10	0.13	0	6	11344.58	23232.19	1397.5	1397.5	1	H1-1a	
14	M135	1.5X1.5X0.083	0.4	46.92	6	0.01	90.08	y 3	2926.03	14085.15	624.42	624.42	1.14	H1-1a	
15	M109	1.5X1.5X0.083	0.4	46.92	6	0.01	90.08	y 3	2926.03	14085.15	624.42	624.42	1.14	H1-1a	
16	M74	PIPE2.0A21165	0.39	7.45	10	0.11	4.14	10	11344.58	23232.19	1397.5	1397.5	1	H1-1b	
17	M6	PIPE2.0A21165	0.39	7.45	10	0.11	4.14	10	11344.58	23232.19	1397.5	1397.5	1	H1-1b	
18	M106	PIPE2.0A21165	0.38	3.31	10	0.14	0	6	11344.58	23232.19	1397.5	1397.5	1	H1-1a	
19	M134	PIPE2.0A21165	0.38	3.31	10	0.14	0	6	11344.58	23232.19	1397.5	1397.5	1	H1-1a	
20	M129	1.5X1.5X0.083	0.36	46.92	6	0	90.08	y 9	2926.03	14085.15	624.42	624.42	1.14	H1-1a	
21	M117	1.5X1.5X0.083	0.36	46.92	6	0	90.08	y 9	2926.03	14085.15	624.42	624.42	1.14	H1-1a	
22	M123	1.5X1.5X0.083	0.36	46.92	6	0	90.08	y 3	2926.03	14085.15	624.42	624.42	1.14	H1-1a	
23	M126	1.5X1.5X0.083	0.36	46.92	6	0	90.08	y 5	2926.03	14085.15	624.42	624.42	1.14	H1-1a	
24	M120	1.5X1.5X0.083	0.36	46.92	6	0	90.08	y 5	2926.03	14085.15	624.42	624.42	1.14	H1-1a	
25	M132	1.5X1.5X0.083	0.35	46.92	6	0	90.08	y 10	2926.03	14085.15	624.42	624.42	1.14	H1-1a	
26	M114	1.5X1.5X0.083	0.35	46.92	6	0	90.08	y 10	2926.03	14085.15	624.42	624.42	1.14	H1-1a	
27	M136	PIPE2.0A21165	0.23	45.29	10	0.13	45.81	6	17602.61	23232.19	1397.5	1397.5	1	H1-1b	

**Envelope AISC 15TH (360-16): ASD Member Steel Code Checks (Continued)**

Member	Shape	Code Check	Loc[in]	Lc	Shear Check	Loc[in]	Dir	Lc	Pnc/om [lb]	Pnt/om [lb]	Mnyy/om [lb-ft]	Mnzz/om [lb-ft]	Cb	Eqn
28	M110	PIPE2.0A21165	0.23	45.29	10	0.13	45.81	6	17602.61	23232.19	1397.5	1397.5	1	H1-1b
29	M124	PIPE2.0A21165	0.21	45.29	10	0.12	45.81	6	17602.61	23232.19	1397.5	1397.5	1	H1-1b
30	M130	PIPE2.0A21165	0.21	45.29	10	0.12	45.81	6	17602.61	23232.19	1397.5	1397.5	1	H1-1b
31	M118	PIPE2.0A21165	0.21	45.29	10	0.12	45.81	6	17602.61	23232.19	1397.5	1397.5	1	H1-1b
32	M127	PIPE2.0A21165	0.21	45.29	10	0.12	45.81	6	17602.61	23232.19	1397.5	1397.5	1	H1-1b
33	M121	PIPE2.0A21165	0.21	45.29	10	0.12	45.81	6	17602.61	23232.19	1397.5	1397.5	1	H1-1b
34	M133	PIPE2.0A21165	0.21	45.29	10	0.12	45.81	6	17602.61	23232.19	1397.5	1397.5	1	H1-1b
35	M115	PIPE2.0A21165	0.21	45.29	10	0.12	45.81	6	17602.61	23232.19	1397.5	1397.5	1	H1-1b
36	M75	1.5X1.5X0.083	0.17	90.08	6	0.07	90.08	y 3	2926.03	14085.15	624.42	624.42	1.14	H1-1b*
37	M15	1.5X1.5X0.083	0.17	90.08	6	0.07	90.08	y 3	2926	14085.15	624.42	624.42	1.14	H1-1b*

**Envelope AA ADM1-15: ASD - BUILDING Member Aluminum Code Checks**

Member	Shape	Code Check	Loc[in]	Lc	Shear Check	Loc[in]	Dir	Lc	Pnc/Om[lb]	Pnt/Om[lb]	Mny/Om[lb-ft]	Mnz/Om[lb-ft]	Vny/Om[lb]	Vnz/Om[lb]	Cb	Eqn
1	M169	HR300/SMR300	0.86	42	11	0.07	42	y 11	5150.89	14342.56	533.92	934.62	7307.69	3206.15	3.27	H.1-1
2	M160	HR300/SMR300	0.86	42	11	0.07	42	y 11	5150.89	14342.56	533.92	934.62	7307.69	3206.15	3.27	H.1-1
3	M166	HR300/SMR300	0.86	42	11	0.07	42	y 11	5150.89	14342.56	533.92	934.62	7307.69	3206.15	3.27	H.1-1
4	M163	HR300/SMR300	0.86	42	11	0.07	42	y 11	5150.89	14342.56	533.92	934.62	7307.69	3206.15	3.27	H.1-1
5	M172	HR300/SMR300	0.86	42	11	0.07	42	y 11	5150.89	14342.56	533.92	934.62	7307.69	3206.15	3.27	H.1-1
6	M157	HR300/SMR300	0.86	42	11	0.07	42	y 11	5150.89	14342.56	533.92	934.62	7307.69	3206.15	3.27	H.1-1
7	M175	HR300/SMR300	0.86	42	11	0.07	42	y 11	5150.89	14342.56	533.92	934.62	7307.69	3206.15	3.27	H.1-1
8	M154	HR300/SMR300	0.86	42	11	0.07	42	y 11	5150.89	14342.56	533.92	934.62	7307.69	3206.15	3.27	H.1-1
9	M151	HR300/SMR300	0.84	42	11	0.07	42	y 11	5150.89	14342.56	533.92	934.62	7307.69	3206.15	3.27	H.1-1
10	M178	HR300/SMR300	0.84	42	11	0.07	42	y 11	5150.89	14342.56	533.92	934.62	7307.69	3206.15	3.27	H.1-1
11	M101	HR300/SMR300	0.84	126	10	0.1	42	y 11	5150.89	14342.56	533.92	934.62	7307.69	3206.15	3.23	H.1-1
12	M100	HR300/SMR300	0.84	126	10	0.1	42	y 11	5150.89	14342.56	533.92	934.62	7307.69	3206.15	3.24	H.1-1
13	M107	HR300/SMR300	0.83	126	10	0.09	42	y 11	5150.89	14342.56	533.92	934.62	7307.69	3206.15	3.19	H.1-1
14	M97	HR300/SMR300	0.83	126	10	0.09	42	y 11	5150.89	14342.56	533.92	934.62	7307.69	3206.15	3.19	H.1-1
15	M91	HR300/SMR300	0.83	126	10	0.07	126	y 10	5150.89	14342.56	533.92	934.62	7307.69	3206.15	3.21	H.1-1
16	M47	HR300/SMR300	0.83	126	10	0.07	126	y 10	5150.89	14342.56	533.92	934.62	7307.69	3206.15	3.21	H.1-1
17	M85	HR300/SMR300	0.83	126	10	0.07	42	y 11	5150.89	14342.56	533.92	934.62	7307.69	3206.15	3.21	H.1-1
18	M53	HR300/SMR300	0.83	126	10	0.07	42	y 11	5150.89	14342.56	533.92	934.62	7307.69	3206.15	3.21	H.1-1
19	M59	HR300/SMR300	0.83	126	10	0.07	42	y 11	5150.89	14342.56	533.92	934.62	7307.69	3206.15	3.21	H.1-1
20	M79	HR300/SMR300	0.83	126	10	0.07	42	y 11	5150.89	14342.56	533.92	934.62	7307.69	3206.15	3.21	H.1-1
21	M94	HR300/SMR300	0.83	126	10	0.07	126	y 10	5150.89	14342.56	533.92	934.62	7307.69	3206.15	3.2	H.1-1
22	M44	HR300/SMR300	0.83	126	10	0.07	126	y 10	5150.89	14342.56	533.92	934.62	7307.69	3206.15	3.2	H.1-1
23	M68	HR300/SMR300	0.83	126	10	0.07	42	y 11	5150.89	14342.56	533.92	934.62	7307.69	3206.15	3.21	H.1-1
24	M65	HR300/SMR300	0.83	126	10	0.07	42	y 11	5150.89	14342.56	533.92	934.62	7307.69	3206.15	3.21	H.1-1
25	M76	HR300/SMR300	0.83	126	10	0.07	42	y 11	5150.89	14342.56	533.92	934.62	7307.69	3206.15	3.21	H.1-1
26	M62	HR300/SMR300	0.83	126	10	0.07	42	y 11	5150.89	14342.56	533.92	934.62	7307.69	3206.15	3.21	H.1-1
27	M82	HR300/SMR300	0.83	126	10	0.07	42	y 11	5150.89	14342.56	533.92	934.62	7307.69	3206.15	3.21	H.1-1
28	M56	HR300/SMR300	0.83	126	10	0.07	42	y 11	5150.89	14342.56	533.92	934.62	7307.69	3206.15	3.21	H.1-1
29	M50	HR300/SMR300	0.82	126	10	0.07	42	y 11	5150.89	14342.56	533.92	934.62	7307.69	3206.15	3.2	H.1-1
30	M88	HR300/SMR300	0.82	126	10	0.07	42	y 11	5150.89	14342.56	533.92	934.62	7307.69	3206.15	3.2	H.1-1



JOB NO.: U2716.0386.241

PROJECT: SunTurf Package A17

SUBJECT: SP - 20 Degrees

DESIGN APPROACH ASD

CONNECTION CAPACITY

Location: Column Base (set screws)

Connection Type: M16 Conical Set Screws

Tensile Capacity: 2600 lbs

Tension Load: 1702 lbs

Check Connection: 65.5%

Result: **Select M16 Conical Set Screws**

Note: Uplift capacity. FOS of (2)

CONNECTION CAPACITY

Location: Column to Cross Beam

Connection Type: K10341-002

Tensile Capacity: 2195 lbs

Tension Load: 1374 lbs

Check Connection: 62.6%

Result: **Select K10341-002**

Note: Uplift capacity. FOS of (2)



JOB NO.: U2716.0386.241

PROJECT: SunTurf Package A17

SUBJECT: SP - 20 Degrees

**CONNECTION CAPACITY**

Location: Brace to Column

Connection Type: K10219-001

Capacity: 1563 lbs

Tension Load: 1388 lbs

Check Connection: 88.8%

Result: **Select K10219-001**

Note: Axial capacity. FOS of (2)

**BOLTED TENSION CONNECTION**

Location: Rail to Cross Beam

Bolt Grade: A304 SS (A2-70)

Bolt Diameter: 0.375 in

Number of Bolts: 2

Bolt Capacity: 8410 lbs (AISC Equation J3-1)

Tension Load: 538 lbs

Check Bolt: 6.4%

Result: **Select (2) 0.375 in. dia. A304 SS (A2-70) bolts.**

Note:



JOB NO.: U2716.0386.241

**PROJECT:** Sunturf Package A17 Ground Mount

---

# ALTERNATE FOUNDATION OPTION 1: DRILLED CONCRETE PIER



PROJECT: Sunturf Package A17 Ground Mount

**DRILLED CONCRETE PIER DESIGN**

**Column Reactions:**

Max. Shear, V [k]:	1.9	Max. Down, P <sub>d</sub> [k]:	3.9
Max. Moment, M [k-ft]:	0.0	Max. Uplift, P <sub>u</sub> [k]:	2.4

**Pier Properties:**

Pier Shape:	Round	Volume of Concrete [ft <sup>3</sup> ]:	15
Pier Diameter, b [ft]:	2.0	Volume of Concrete [yd <sup>3</sup> ]:	0.6
Top of Pier Elevation [ft]:	0.00	Weight of Concrete [k]:	2.2
Pier Depth, d [ft]:	4.75		

**Soil Properties:**

Allow. Bearing Pressure [psf]:	1,500	<u>Optional Parameters for Uplift:</u>	
1/3 increase for short term loads?	No		
Lateral Bearing, S [pcf]:	150	Skin Friction* [psf]:	250
Max. Lateral Bearing (opt'l) [psf]:		Top Length to Ignore [ft]:	0
Top Depth to Ignore [ft]:	0	1/3 increase for short term loads?	No
1/3 increase for short term loads?	No	Combine w/ Bearing:	No
1/2" deflection at t/o pier allowed:	Yes		

\*per IBC Section 1810.3.3.1.4

**Check Bearing:**

Bearing Capacity [k]:	7.5
-----------------------	-----

**Bearing capacity OK.**

**Check Uplift:**

Uplift Capacity [k]:	9.5
----------------------	-----

**Uplift capacity OK.**

**Check Lateral Bearing:**

Top of Pier Constrained?:	No
Applied Lateral Force, P [lb]:	1,900
Point of Application, h [ft]:	0.0
S <sub>max</sub> [psf]:	
S [psf]:	475
A = 2.34*P/(Sb):	4.68
Required Pier Depth, d <sub>reqd</sub> [ft]:	4.70

IBC Section 1807.3.2.1

IBC Eq. 18-1

Result: **Lateral bearing capacity OK.**





JOB NO.: U2716.0386.241

**PROJECT:** Sunturf Package A17 Ground Mount

---

# ALTERNATE FOUNDATION OPTION 2: CONCRETE BALLAST BLOCK

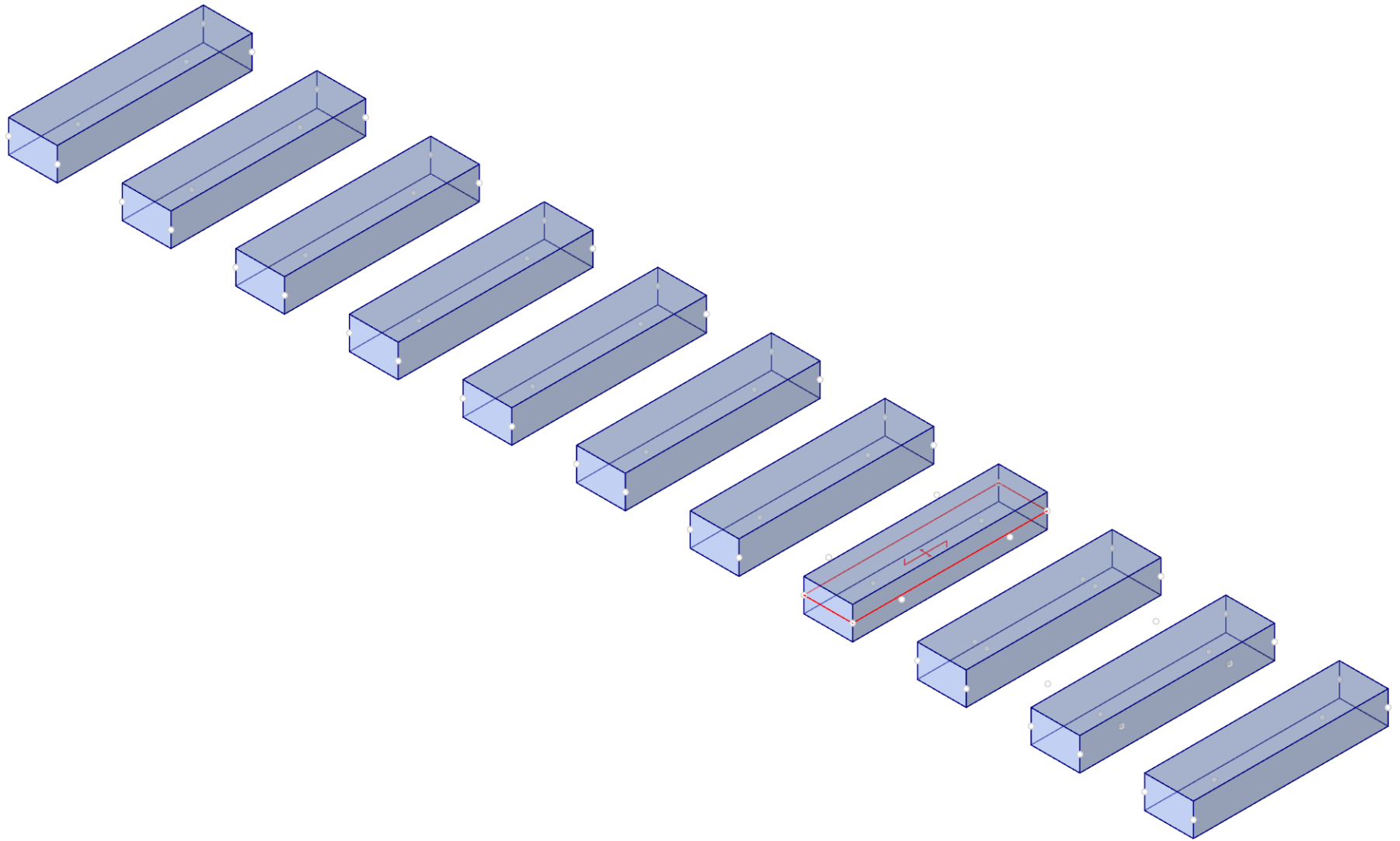

Vector Structural Engineering  
MIH  
U2716.0386.241

SunTurf A17

SK-1  
Mar 25, 2024 at 12:49 PM  
Sunturf A17 - SP - 35deg.r3d

**Concrete Properties**

	Label	E [ksi]	G [ksi]	Nu	Therm. Coeff. [1e <sup>5</sup> F <sup>-1</sup> ]	Density [lb/ft <sup>3</sup> ]	f <sub>c</sub> [psi]	Lambda	Flex Steel [psi]	Shear Steel [psi]
1	Conc3000NW	3156	1372	0.15	0.6	145	3000	1	60000	60000
2	Conc3500NW	3409	1482	0.15	0.6	145	3500	1	60000	60000
3	Conc4000NW	3644	1584	0.15	0.6	145	4000	1	60000	60000
4	Conc3000LW	2085	907	0.15	0.6	109.999	3000	0.75	60000	60000
5	Conc3500LW	2252	979	0.15	0.6	109.999	3500	0.75	60000	60000
6	Conc4000LW	2408	1047	0.15	0.6	109.999	4000	0.75	60000	60000
7	Conc2500NW	3156	1372	0.15	0.6	145	2500	1	60000	60000

**Design Rules - Mat Slab**

	Label	Max Bending Chk	Max Shear Chk	Top Bar	Bottom Bar	Min Top Bar Spacing [in]	Max Top Bar Spacing [in]	Min Bot Bar Spacing [in]	Max Bot Bar Spacing [in]	Spacing Increment [in]	Top Cover [in]	Bottom Cover [in]	Side Cover [in]	Rebar Options
1	Typical	1	1	#5	#5	3	16	3	16	1	3	3	1.5	Optimize

**Soil Definitions**

	Label	Layers	Subgrade Modulus [lb/ft <sup>3</sup> ]	Allowable Bearing [psf]	Default
1	Default	Single	1e+5	1500	Yes

**Slab**

	Label	Thickness [in]	Material	Local Axis Angle [deg]	Analysis Offset [in]	Passive Pressure [psf]	Soil Overburden [psf]	Icr Factor
1	S1	24	Conc2500NW	0	0	0	0	0.25
2	S2	24	Conc2500NW	0	0	0	0	0.25
3	S3	24	Conc2500NW	0	0	0	0	0.25
4	S4	24	Conc2500NW	0	0	0	0	0.25
5	S5	24	Conc2500NW	0	0	0	0	0.25
6	S6	24	Conc2500NW	0	0	0	0	0.25
7	S7	24	Conc2500NW	0	0	0	0	0.25
8	S8	24	Conc2500NW	0	0	0	0	0.25
9	S9	24	Conc2500NW	0	0	0	0	0.25
10	S10	24	Conc2500NW	0	0	0	0	0.25
11	S11	24	Conc2500NW	0	0	0	0	0.25

**Load Category**

	Category	Node Loads
1	DL	28
2	RLL	40
3	WLZ	48
4	OL1	60
5	OL2	60
6	OL3	60
7	OL4	56

**Load Combination**

	Label	Solve	Service	SF	Category	Factor	Category	Factor	Category	Factor
1	ASD Loads									
2	1.0 D	Yes	Yes	1.5	DL	1				
3	1.0 D + 1.0 S	Yes	Yes	1.5	DL	1	RLL	1		
4	1.0 D + 0.6 W1	Yes	Yes	1.5	DL	1	RLL		OL1	0.6
5	1.0 D + 0.6 W2	Yes	Yes	1.5	DL	1	RLL		OL2	0.6
6	1.0 D + 0.6 W3	Yes	Yes	1.5	DL	1	RLL		OL3	0.6

**Load Combination (Continued)**

	Label	Solve	Service	SF	Category	Factor	Category	Factor	Category	Factor
7	1.0 D + 0.6 W4	Yes	Yes	1.5	DL	1	RLL		OL4	0.6
8	1.0 D + 0.45 W1 + 0.75 S	Yes	Yes	1.5	DL	1	RLL	0.75	OL1	0.45
9	1.0 D + 0.45 W2 + 0.75 S	Yes	Yes	1.5	DL	1	RLL	0.75	OL2	0.45
10	1.0 D + 0.45 W3 + 0.75 S	Yes	Yes	1.5	DL	1	RLL	0.75	OL3	0.45
11	1.0 D + 0.45 W4 + 0.75 S	Yes	Yes	1.5	DL	1	RLL	0.75	OL4	0.45
12	0.6 D + 0.6 W1	Yes	Yes		DL	0.6	RLL		OL1	0.6
13	0.6 D + 0.6 W2	Yes	Yes		DL	0.6	RLL		OL2	0.6
14	0.6 D + 0.6 W3	Yes	Yes		DL	0.6	RLL		OL3	0.6
15	0.6 D + 0.6 W4	Yes	Yes		DL	0.6	RLL		OL4	0.6
16										
17	LRFD Loads									
18	1.4 D	Yes			DL	1.4	RLL			
19	1.2 D + 1.6 S + 0.5 W1	Yes			DL	1.2	RLL	1.6	OL1	0.5
20	1.2 D + 1.6 S + 0.5 W2	Yes			DL	1.2	RLL	1.6	OL2	0.5
21	1.2 D + 1.6 S + 0.5 W3	Yes			DL	1.2	RLL	1.6	OL3	0.5
22	1.2 D + 1.6 S + 0.5 W4	Yes			DL	1.2	RLL	1.6	OL4	0.5
23	1.2 D + 1.0 W1	Yes			DL	1.2	RLL		OL1	1
24	1.2 D + 1.0 W2	Yes			DL	1.2	RLL		OL2	1
25	1.2 D + 1.0 W3	Yes			DL	1.2	RLL		OL3	1
26	1.2 D + 1.0 W4	Yes			DL	1.2	RLL		OL4	1
27	0.9 D + 1.0 W1	Yes			DL	0.9	RLL		OL1	1
28	0.9 D + 1.0 W2	Yes			DL	0.9	RLL		OL2	1
29	0.9 D + 1.0 W3	Yes			DL	0.9	RLL		OL3	1
30	0.9 D + 1.0 W4	Yes			DL	0.9	RLL		OL4	1

**Strip Reinforcing**

	Label	UC	Top	LC	Top	Bars	Gov	Design	Cut	UC	Top	UC	Bot	LC	Bot	Bars	Gov	Design	Cut	UC	Bot	UC	Shear	LC	Gov	Design	Cut	UC	Shear
1	DS1	0.01	24	#5@6in		DS1-X13	0.01	20	#5@6in		DS1-X38	0.04	21		DS1-X17														
2	DS2	0	27	#5@6in		DS2-X25	0	21	#5@6in		DS2-X25	0.01	21		DS2-X16														

**Envelope Slab Soil Pressures**

	Label	Max UC	Max LC	Soil Pressure[psf]	Allowable Bearing[psf]	Node
1	S1	0.31	10	460.68	1500	N386
2	S2	0.35	10	524.36	1500	N395
3	S3	0.37	10	553.44	1500	N404
4	S4	0.37	10	549.11	1500	N413
5	S5	0.37	10	550.07	1500	N422
6	S6	0.37	10	549.8	1500	N431
7	S7	0.37	10	550.08	1500	N440
8	S8	0.37	10	549.12	1500	N449
9	S9	0.37	10	553.45	1500	N458
10	S10	0.35	10	524.36	1500	N467
11	S11	0.31	10	460.69	1500	N476

**Slab Stability - Overturning**

	LC	Slab	Angle[deg]	Mo-xx[lb-ft]	Ms-xx[lb-ft]	Mo-zz[lb-ft]	Ms-zz[lb-ft]	Ms-xx/Mo-xx	Ms-zz/Mo-zz
1	2	S1	0	0	64107.14	0	16166.6	9.99+	9.99+
2	2	S2	0	0	65119.93	0	16264.28	9.99+	9.99+
3	2	S3	0	0	65049.81	0	16290.89	9.99+	9.99+
4	2	S4	0	0	65065.44	0	16288.11	9.99+	9.99+
5	2	S5	0	0	65063.36	0	16288.79	9.99+	9.99+
6	2	S6	0	0	65063.63	0	16288.58	9.99+	9.99+



Company : Vector Structural Engineering  
 Designer : MIH  
 Job Number : U2716.0386.241  
 Model Name : SunTurf A17

3/25/2024  
 12:50:46 PM  
 Checked By : \_\_\_\_\_

**Slab Stability - Overturning (Continued)**

	LC	Slab	Angle[deg]	Mo-xx[lb-ft]	Ms-xx[lb-ft]	Mo-zz[lb-ft]	Ms-zz[lb-ft]	Ms-xx/Mo-xx	Ms-zz/Mo-zz
7	2	S7	0	0	65063.37	0	16288.8	9.99+	9.99+
8	2	S8	0	0	65065.45	0	16288.11	9.99+	9.99+
9	2	S9	0	0	65049.82	0	16290.89	9.99+	9.99+
10	2	S10	0	0	65119.96	0	16269.29	9.99+	9.99+
11	2	S11	0	0	64107.12	0	16013.12	9.99+	9.99+
12	3	S1	0	0	77564.63	0	20757.76	9.99+	9.99+
13	3	S2	0	0	90865.08	0	22391.7	9.99+	9.99+
14	3	S3	0	0	89937.01	0	22697.18	9.99+	9.99+
15	3	S4	0	0	90136.87	0	22662.45	9.99+	9.99+
16	3	S5	0	0	90111.63	0	22672.88	9.99+	9.99+
17	3	S6	0	0	90115.53	0	22670.44	9.99+	9.99+
18	3	S7	0	0	90111.77	0	22672.97	9.99+	9.99+
19	3	S8	0	0	90136.87	0	22667.18	9.99+	9.99+
20	3	S9	0	0	89937.05	0	22697.79	9.99+	9.99+
21	3	S10	0	0	90865.58	0	22432.71	9.99+	9.99+
22	3	S11	0	0	77564.2	0	18994.84	9.99+	9.99+
23	4	S1	0	13035.46	64611.78	2063.68	16166.6	4.96	7.83
24	4	S2	0	22088.75	65014.29	2530.94	16269.28	2.94	6.43
25	4	S3	0	22524.15	65277.27	2732.08	16290.89	2.9	5.96
26	4	S4	0	22486.83	65239.4	2700.97	16288.11	2.9	6.03
27	4	S5	0	22509.83	65246.95	2705.87	16288.79	2.9	6.02
28	4	S6	0	22499.96	65245.05	2702.11	16288.58	2.9	6.03
29	4	S7	0	22510.67	65247	2705.92	16288.8	2.9	6.02
30	4	S8	0	22487.85	65239.43	2701.01	16288.11	2.9	6.03
31	4	S9	0	22524.47	65277.3	2732.12	16290.89	2.9	5.96
32	4	S10	0	22088.43	65014.35	2530.88	16269.29	2.94	6.43
33	4	S11	0	13036.3	64611.75	2063.74	16166.6	4.96	7.83
34	5	S1	0	13756.51	64611.78	1978.1	16166.6	4.7	8.17
35	5	S2	0	21436.84	65014.29	1922.87	16264.28	3.03	8.46
36	5	S3	0	22709.16	65277.27	2308.97	16290.89	2.87	7.06
37	5	S4	0	22543.89	65239.4	2244.17	16288.11	2.89	7.26
38	5	S5	0	22591.36	65246.95	2255.68	16288.79	2.89	7.22
39	5	S6	0	22575.7	65245.05	2250.18	16288.58	2.89	7.24
40	5	S7	0	22592.27	65247	2255.75	16288.8	2.89	7.22
41	5	S8	0	22544.94	65239.43	2244.21	16288.11	2.89	7.26
42	5	S9	0	22709.54	65277.3	2309.02	16290.89	2.87	7.06
43	5	S10	0	21436.64	65014.35	1922.88	16264.29	3.03	8.46
44	5	S11	0	13756.97	64611.75	1978.12	16166.6	4.7	8.17
45	6	S1	0	0	64478.25	0	18572.39	9.99+	9.99+
46	6	S2	0	2229.31	65119.93	0	19194.07	9.99+	9.99+
47	6	S3	0	814.59	65049.81	0	19466.77	9.99+	9.99+
48	6	S4	0	1063.33	65065.44	0	19427.19	9.99+	9.99+
49	6	S5	0	1021.3	65063.36	0	19439.37	9.99+	9.99+
50	6	S6	0	1029.45	65063.63	0	19438.64	9.99+	9.99+
51	6	S7	0	1021.79	65063.37	0	19443.3	9.99+	9.99+
52	6	S8	0	1064.22	65065.45	0	19436.88	9.99+	9.99+
53	6	S9	0	814.6	65049.82	0	19475.93	9.99+	9.99+
54	6	S10	0	2229.38	65119.96	0	19219.73	9.99+	9.99+
55	6	S11	0	0	64477.84	0	17499.3	9.99+	9.99+
56	7	S1	0	0	65882.4	0	18111.91	9.99+	9.99+
57	7	S2	0	0	67139.84	0	19067.27	9.99+	9.99+
58	7	S3	0	0	67630.41	0	19142.61	9.99+	9.99+
59	7	S4	0	0	67550.86	0	19133.99	9.99+	9.99+
60	7	S5	0	0	67560.07	0	19138.71	9.99+	9.99+
61	7	S6	0	0	67559.25	0	19139.14	9.99+	9.99+

**Slab Stability - Overturning (Continued)**

	LC	Slab	Angle[deg]	Mo-xx[lb-ft]	Ms-xx[lb-ft]	Mo-zz[lb-ft]	Ms-zz[lb-ft]	Ms-xx/Mo-xx	Ms-zz/Mo-zz
62	7	S7	0	0	67559.69	0	19141.24	9.99+	9.99+
63	7	S8	0	0	67550.13	0	19142.01	9.99+	9.99+
64	7	S9	0	0	67630.43	0	19142.64	9.99+	9.99+
65	7	S10	0	0	67139.52	0	19117.69	9.99+	9.99+
66	7	S11	0	0	65882.05	0	17302.09	9.99+	9.99+
67	8	S1	0	9776.59	77237.61	1547.76	19609.97	7.9	9.99+
68	8	S2	0	16566.56	82577.48	1898.2	20891.73	4.98	9.99+
69	8	S3	0	16893.11	85051.31	2049.06	21096.03	5.03	9.99+
70	8	S4	0	16865.12	84695.92	2025.73	21072.37	5.02	9.99+
71	8	S5	0	16882.37	84765.3	2029.4	21076.86	5.02	9.99+
72	8	S6	0	16874.97	84747.24	2026.58	21074.97	5.02	9.99+
73	8	S7	0	16883	84765.77	2029.44	21076.93	5.02	9.99+
74	8	S8	0	16865.89	84696.25	2025.75	21072.41	5.02	9.99+
75	8	S9	0	16893.36	85051.58	2049.09	21096.07	5.03	9.99+
76	8	S10	0	16566.32	82578.12	1898.16	20891.86	4.98	9.99+
77	8	S11	0	9777.23	77237.28	1547.8	19609.89	7.9	9.99+
78	9	S1	0	10317.38	77237.61	1483.57	19609.97	7.49	9.99+
79	9	S2	0	16077.63	82577.48	1442.15	20859.84	5.14	9.99+
80	9	S3	0	17031.87	85051.31	1731.73	21096.03	4.99	9.99+
81	9	S4	0	16907.92	84695.92	1683.13	21072.37	5.01	9.99+
82	9	S5	0	16943.52	84765.3	1691.76	21076.86	5	9.99+
83	9	S6	0	16931.78	84747.24	1687.64	21074.97	5.01	9.99+
84	9	S7	0	16944.2	84765.77	1691.81	21076.93	5	9.99+
85	9	S8	0	16908.7	84696.25	1683.16	21072.41	5.01	9.99+
86	9	S9	0	17032.15	85051.58	1731.76	21096.07	4.99	9.99+
87	9	S10	0	16077.48	82578.12	1442.16	20859.97	5.14	9.99+
88	9	S11	0	10317.73	77237.28	1483.59	19609.89	7.49	9.99+
89	10	S1	0	0	74478.59	0	21414.31	9.99+	9.99+
90	10	S2	0	1671.98	84428.79	0	23057.19	9.99+	9.99+
91	10	S3	0	610.95	83715.21	0	23477.52	9.99+	9.99+
92	10	S4	0	797.5	83869.01	0	23423.18	9.99+	9.99+
93	10	S5	0	765.98	83849.56	0	23439.8	9.99+	9.99+
94	10	S6	0	772.08	83852.56	0	23437.52	9.99+	9.99+
95	10	S7	0	766.34	83849.67	0	23442.8	9.99+	9.99+
96	10	S8	0	798.16	83869.02	0	23433.99	9.99+	9.99+
97	10	S9	0	610.95	83715.24	0	23484.85	9.99+	9.99+
98	10	S10	0	1672.03	84429.17	0	23104.69	9.99+	9.99+
99	10	S11	0	0	74477.97	0	19364.04	9.99+	9.99+
100	11	S1	0	0	75531.7	0	21068.95	9.99+	9.99+
101	11	S2	0	0	85943.73	0	22962.09	9.99+	9.99+
102	11	S3	0	0	85650.66	0	23234.39	9.99+	9.99+
103	11	S4	0	0	85733.07	0	23203.27	9.99+	9.99+
104	11	S5	0	0	85722.09	0	23214.3	9.99+	9.99+
105	11	S6	0	0	85724.27	0	23212.89	9.99+	9.99+
106	11	S7	0	0	85721.91	0	23216.26	9.99+	9.99+
107	11	S8	0	0	85732.53	0	23212.84	9.99+	9.99+
108	11	S9	0	0	85650.7	0	23234.88	9.99+	9.99+
109	11	S10	0	0	85943.84	0	23028.15	9.99+	9.99+
110	11	S11	0	0	75531.13	0	19216.14	9.99+	9.99+
111	12	S1	0	13035.46	38767.07	2063.68	9699.96	2.97	4.7
112	12	S2	0	22088.75	39008.58	2530.94	9761.57	1.77	3.86
113	12	S3	0	22524.15	39166.36	2732.08	9774.53	1.74	3.58
114	12	S4	0	22486.83	39143.64	2700.97	9772.86	1.74	3.62
115	12	S5	0	22509.83	39148.17	2705.87	9773.27	1.74	3.61
116	12	S6	0	22499.96	39147.03	2702.11	9773.15	1.74	3.62

**Slab Stability - Overturning (Continued)**

	LC	Slab	Angle[deg]	Mo-xx[lb-ft]	Ms-xx[lb-ft]	Mo-zz[lb-ft]	Ms-zz[lb-ft]	Ms-xx/Mo-xx	Ms-zz/Mo-zz
117	12	S7	0	22510.67	39148.2	2705.92	9773.28	1.74	3.61
118	12	S8	0	22487.85	39143.66	2701.01	9772.87	1.74	3.62
119	12	S9	0	22524.47	39166.38	2732.12	9774.53	1.74	3.58
120	12	S10	0	22088.43	39008.61	2530.88	9761.57	1.77	3.86
121	12	S11	0	13036.3	38767.05	2063.74	9699.96	2.97	4.7
122	13	S1	0	13756.51	38767.07	1978.1	9699.96	2.82	4.9
123	13	S2	0	21436.84	39008.58	1922.87	9758.57	1.82	5.08
124	13	S3	0	22709.16	39166.36	2308.97	9774.53	1.72	4.23
125	13	S4	0	22543.89	39143.64	2244.17	9772.86	1.74	4.35
126	13	S5	0	22591.36	39148.17	2255.68	9773.27	1.73	4.33
127	13	S6	0	22575.7	39147.03	2250.18	9773.15	1.73	4.34
128	13	S7	0	22592.27	39148.2	2255.75	9773.28	1.73	4.33
129	13	S8	0	22544.94	39143.66	2244.21	9772.87	1.74	4.35
130	13	S9	0	22709.54	39166.38	2309.02	9774.53	1.72	4.23
131	13	S10	0	21436.64	39008.61	1922.88	9758.57	1.82	5.07
132	13	S11	0	13756.97	38767.05	1978.12	9699.96	2.82	4.9
133	14	S1	0	0	38835.39	0	12105.74	9.99+	9.99+
134	14	S2	0	2229.31	39071.96	0	12688.36	9.99+	9.99+
135	14	S3	0	814.59	39029.89	0	12950.42	9.99+	9.99+
136	14	S4	0	1063.33	39039.27	0	12911.95	9.99+	9.99+
137	14	S5	0	1021.3	39038.02	0	12923.86	9.99+	9.99+
138	14	S6	0	1029.45	39038.18	0	12923.21	9.99+	9.99+
139	14	S7	0	1021.79	39038.02	0	12927.78	9.99+	9.99+
140	14	S8	0	1064.22	39039.27	0	12921.63	9.99+	9.99+
141	14	S9	0	814.6	39029.89	0	12959.58	9.99+	9.99+
142	14	S10	0	2229.38	39071.98	0	12712.02	9.99+	9.99+
143	14	S11	0	0	38834.99	0	11094.05	9.99+	9.99+
144	15	S1	0	0	40239.54	0	11645.27	9.99+	9.99+
145	15	S2	0	0	41091.87	0	12561.56	9.99+	9.99+
146	15	S3	0	0	41610.48	0	12626.25	9.99+	9.99+
147	15	S4	0	0	41524.68	0	12618.75	9.99+	9.99+
148	15	S5	0	0	41534.73	0	12623.19	9.99+	9.99+
149	15	S6	0	0	41533.8	0	12623.71	9.99+	9.99+
150	15	S7	0	0	41534.34	0	12625.72	9.99+	9.99+
151	15	S8	0	0	41523.96	0	12626.76	9.99+	9.99+
152	15	S9	0	0	41610.5	0	12626.29	9.99+	9.99+
153	15	S10	0	0	41091.53	0	12609.97	9.99+	9.99+
154	15	S11	0	0	40239.21	0	10896.84	9.99+	9.99+

**Slab Stability - Sliding**

	LC	Slab	Angle[deg]	Va-xx[lb]	Vr-xx[lb]	Va-zz[lb]	Vr-zz[lb]	SR-xx	SR-zz
1	2	S1	0	38.37	3217.97	0	3217.97	9.99+	9.99+
2	2	S2	0	1.25	3253.36	0	3253.36	9.99+	9.99+
3	2	S3	0	0	3258.18	0	3258.18	9.99+	9.99+
4	2	S4	0	0	3257.62	0	3257.62	9.99+	9.99+
5	2	S5	0	0	3257.76	0	3257.76	9.99+	9.99+
6	2	S6	0	0	3257.72	0	3257.72	9.99+	9.99+
7	2	S7	0	0	3257.76	0	3257.76	9.99+	9.99+
8	2	S8	0	0	3257.62	0	3257.62	9.99+	9.99+
9	2	S9	0	0	3258.18	0	3258.18	9.99+	9.99+
10	2	S10	0	1.25	3253.36	0	3253.36	9.99+	9.99+
11	2	S11	0	38.37	3217.97	0	3217.97	9.99+	9.99+
12	3	S1	0	440.7	3975.27	0	3975.27	9.02	9.99+
13	3	S2	0	10.21	4482.42	0	4482.42	9.99+	9.99+
14	3	S3	0	0.14	4539.49	2.01	4539.49	9.99+	9.99+

**Slab Stability - Sliding (Continued)**

	LC	Slab	Angle[deg]	Va-xx[lb]	Vr-xx[lb]	Va-zz[lb]	Vr-zz[lb]	SR-xx	SR-zz
15	3	S4	0	1.17	4532.96	1.83	4532.96	9.99+	9.99+
16	3	S5	0	0	4534.58	0	4534.58	9.99+	9.99+
17	3	S6	0	0	4534.09	0	4534.09	9.99+	9.99+
18	3	S7	0	0	4534.59	0	4534.59	9.99+	9.99+
19	3	S8	0	1.17	4532.97	1.84	4532.97	9.99+	9.99+
20	3	S9	0	0.14	4539.5	2.01	4539.5	9.99+	9.99+
21	3	S10	0	10.21	4482.46	0	4482.46	9.99+	9.99+
22	3	S11	0	440.7	3975.25	0	3975.25	9.02	9.99+
23	4	S1	0	158.86	2884.13	573.74	2884.13	9.99+	5.03
24	4	S2	0	3.19	2748.94	1418.7	2748.94	9.99+	1.94
25	4	S3	0	1.95	2712.54	1231.35	2712.54	9.99+	2.2
26	4	S4	0	2.07	2718.25	1266.89	2718.25	9.99+	2.15
27	4	S5	0	0.83	2716.91	1260.32	2716.91	9.99+	2.16
28	4	S6	0	0	2717.29	1261.77	2717.29	9.99+	2.15
29	4	S7	0	0.83	2716.9	1260.37	2716.9	9.99+	2.16
30	4	S8	0	2.07	2718.25	1266.97	2718.25	9.99+	2.15
31	4	S9	0	1.96	2712.54	1231.37	2712.54	9.99+	2.2
32	4	S10	0	3.19	2748.96	1418.63	2748.96	9.99+	1.94
33	4	S11	0	158.86	2884.11	573.78	2884.11	9.99+	5.03
34	5	S1	0	175.1	2907.74	480.93	2907.74	9.99+	6.05
35	5	S2	0	5.05	2870.3	1178.98	2870.3	9.99+	2.43
36	5	S3	0	3.8	2797.9	1025	2797.9	9.99+	2.73
37	5	S4	0	1.93	2809.56	1055.36	2809.56	9.99+	2.66
38	5	S5	0	0.97	2807.01	1049.67	2807.01	9.99+	2.67
39	5	S6	0	0	2807.68	1050.93	2807.68	9.99+	2.67
40	5	S7	0	0.97	2807	1049.72	2807	9.99+	2.67
41	5	S8	0	1.93	2809.55	1055.44	2809.55	9.99+	2.66
42	5	S9	0	3.8	2797.89	1025.01	2797.89	9.99+	2.73
43	5	S10	0	5.05	2870.3	1178.93	2870.3	9.99+	2.43
44	5	S11	0	175.1	2907.74	480.96	2907.74	9.99+	6.05
45	6	S1	0	268.29	3607.16	668.85	3607.16	9.99+	5.39
46	6	S2	0	6.43	3841.39	1653.89	3841.39	9.99+	2.32
47	6	S3	0	2.28	3894.26	1435.48	3894.26	9.99+	2.71
48	6	S4	0	2.41	3886.4	1476.91	3886.4	9.99+	2.63
49	6	S5	0	0.96	3888.26	1469.25	3888.26	9.99+	2.65
50	6	S6	0	0	3887.73	1470.94	3887.73	9.99+	2.64
51	6	S7	0	0.96	3888.27	1469.3	3888.27	9.99+	2.65
52	6	S8	0	2.41	3886.41	1477	3886.41	9.99+	2.63
53	6	S9	0	2.28	3894.27	1435.5	3894.27	9.99+	2.71
54	6	S10	0	6.42	3841.38	1653.8	3841.38	9.99+	2.32
55	6	S11	0	268.29	3607.17	668.9	3607.17	9.99+	5.39
56	7	S1	0	202.48	3541.39	602.44	3541.39	9.99+	5.88
57	7	S2	0	12.63	3818.5	1498.82	3818.5	9.99+	2.55
58	7	S3	0	0	3828.52	1299.36	3828.52	9.99+	2.95
59	7	S4	0	2	3827.6	1336.17	3827.6	9.99+	2.86
60	7	S5	0	0.62	3827.99	1329.43	3827.99	9.99+	2.88
61	7	S6	0	0	3827.83	1330.92	3827.83	9.99+	2.88
62	7	S7	0	0.62	3828	1329.47	3828	9.99+	2.88
63	7	S8	0	2	3827.6	1336.24	3827.6	9.99+	2.86
64	7	S9	0	0	3828.53	1299.38	3828.53	9.99+	2.95
65	7	S10	0	12.62	3818.49	1498.74	3818.49	9.99+	2.55
66	7	S11	0	202.48	3541.41	602.5	3541.41	9.99+	5.88
67	8	S1	0	192.2	3535.56	430.3	3535.56	9.99+	8.22
68	8	S2	0	4.64	3796.85	1064.03	3796.85	9.99+	3.57
69	8	S3	0	1.36	3809.94	925.02	3809.94	9.99+	4.12



**Slab Stability - Sliding (Continued)**

	LC	Slab	Angle[deg]	Va-xx[lb]	Vr-xx[lb]	Va-zz[lb]	Vr-zz[lb]	SR-xx	SR-zz
70	8	S4	0	0.67	3809.6	948.8	3809.6	9.99+	4.02
71	8	S5	0	0.62	3809.74	945.24	3809.74	9.99+	4.03
72	8	S6	0	0	3809.68	946.33	3809.68	9.99+	4.03
73	8	S7	0	0.62	3809.75	945.27	3809.75	9.99+	4.03
74	8	S8	0	0.67	3809.6	948.85	3809.6	9.99+	4.01
75	8	S9	0	1.36	3809.94	925.03	3809.94	9.99+	4.12
76	8	S10	0	4.64	3796.88	1063.97	3796.88	9.99+	3.57
77	8	S11	0	192.2	3535.54	430.34	3535.54	9.99+	8.22
78	9	S1	0	180.02	3553.27	360.7	3553.27	9.99+	9.85
79	9	S2	0	10.82	3887.87	884.24	3887.87	9.99+	4.4
80	9	S3	0	2.74	3873.96	770.26	3873.96	9.99+	5.03
81	9	S4	0	0.57	3878.08	790.15	3878.08	9.99+	4.91
82	9	S5	0	0.73	3877.31	787.26	3877.31	9.99+	4.93
83	9	S6	0	0	3877.47	788.2	3877.47	9.99+	4.92
84	9	S7	0	0.73	3877.31	787.29	3877.31	9.99+	4.92
85	9	S8	0	0.57	3878.08	790.2	3878.08	9.99+	4.91
86	9	S9	0	2.74	3873.96	770.26	3873.96	9.99+	5.03
87	9	S10	0	10.82	3887.89	884.2	3887.89	9.99+	4.4
88	9	S11	0	180.02	3553.25	360.72	3553.25	9.99+	9.85
89	10	S1	0	512.56	4077.84	501.64	4077.84	7.96	8.13
90	10	S2	0	11.85	4616.18	1240.42	4616.18	9.99+	3.72
91	10	S3	0	1.81	4696.23	1075.1	4696.23	9.99+	4.37
92	10	S4	0	2.69	4685.71	1109.06	4685.71	9.99+	4.22
93	10	S5	0	0.72	4688.25	1101.94	4688.25	9.99+	4.25
94	10	S6	0	0	4687.5	1103.21	4687.5	9.99+	4.25
95	10	S7	0	0.72	4688.27	1101.98	4688.27	9.99+	4.25
96	10	S8	0	2.69	4685.72	1109.13	4685.72	9.99+	4.22
97	10	S9	0	1.82	4696.24	1075.12	4696.24	9.99+	4.37
98	10	S10	0	11.85	4616.2	1240.35	4616.2	9.99+	3.72
99	10	S11	0	512.56	4077.83	501.67	4077.83	7.96	8.13
100	11	S1	0	463.2	4028.51	451.83	4028.51	8.7	8.92
101	11	S2	0	16.5	4599.02	1124.12	4599.02	9.99+	4.09
102	11	S3	0	0.11	4646.92	973.02	4646.92	9.99+	4.78
103	11	S4	0	2.38	4641.61	1003.5	4641.61	9.99+	4.63
104	11	S5	0	0.47	4643.05	997.07	4643.05	9.99+	4.66
105	11	S6	0	0	4642.58	998.19	4642.58	9.99+	4.65
106	11	S7	0	0.47	4643.07	997.1	4643.07	9.99+	4.66
107	11	S8	0	2.38	4641.62	1003.56	4641.62	9.99+	4.63
108	11	S9	0	0.11	4646.93	973.03	4646.93	9.99+	4.78
109	11	S10	0	16.5	4599.03	1124.05	4599.03	9.99+	4.09
110	11	S11	0	463.2	4028.51	451.87	4028.51	8.7	8.92
111	12	S1	0	174.2	1596.94	573.74	1596.94	9.17	2.78
112	12	S2	0	3.69	1447.6	1418.7	1447.6	9.99+	1.02
113	12	S3	0	1.95	1409.27	1231.35	1409.27	9.99+	1.14
114	12	S4	0	2.07	1415.2	1266.89	1415.2	9.99+	1.12
115	12	S5	0	0.83	1413.81	1260.32	1413.81	9.99+	1.12
116	12	S6	0	0	1414.21	1261.77	1414.21	9.99+	1.12
117	12	S7	0	0.83	1413.8	1260.37	1413.8	9.99+	1.12
118	12	S8	0	2.07	1415.2	1266.97	1415.2	9.99+	1.12
119	12	S9	0	1.96	1409.26	1231.37	1409.26	9.99+	1.14
120	12	S10	0	3.69	1447.61	1418.63	1447.61	9.99+	1.02
121	12	S11	0	174.2	1596.93	573.78	1596.93	9.17	2.78
122	13	S1	0	190.45	1620.55	480.93	1620.55	8.51	3.37
123	13	S2	0	4.55	1568.96	1178.98	1568.96	9.99+	1.33
124	13	S3	0	3.8	1494.63	1025	1494.63	9.99+	1.46

**Slab Stability - Sliding (Continued)**

	LC	Slab	Angle[deg]	Va-xx[lb]	Vr-xx[lb]	Va-zz[lb]	Vr-zz[lb]	SR-xx	SR-zz
125	13	S4	0	1.93	1506.51	1055.36	1506.51	9.99+	1.43
126	13	S5	0	0.97	1503.91	1049.67	1503.91	9.99+	1.43
127	13	S6	0	0	1504.59	1050.93	1504.59	9.99+	1.43
128	13	S7	0	0.97	1503.89	1049.72	1503.89	9.99+	1.43
129	13	S8	0	1.93	1506.5	1055.44	1506.5	9.99+	1.43
130	13	S9	0	3.8	1494.62	1025.01	1494.62	9.99+	1.46
131	13	S10	0	4.55	1568.96	1178.93	1568.96	9.99+	1.33
132	13	S11	0	190.45	1620.55	480.96	1620.55	8.51	3.37
133	14	S1	0	252.94	2319.97	668.85	2319.97	9.17	3.47
134	14	S2	0	5.93	2540.04	1653.89	2540.04	9.99+	1.54
135	14	S3	0	2.28	2590.99	1435.48	2590.99	9.99+	1.8
136	14	S4	0	2.41	2583.35	1476.91	2583.35	9.99+	1.75
137	14	S5	0	0.96	2585.16	1469.25	2585.16	9.99+	1.76
138	14	S6	0	0	2584.64	1470.94	2584.64	9.99+	1.76
139	14	S7	0	0.96	2585.17	1469.3	2585.17	9.99+	1.76
140	14	S8	0	2.41	2583.36	1477	2583.36	9.99+	1.75
141	14	S9	0	2.28	2591	1435.5	2591	9.99+	1.8
142	14	S10	0	5.92	2540.03	1653.8	2540.03	9.99+	1.54
143	14	S11	0	252.94	2319.99	668.9	2319.99	9.17	3.47
144	15	S1	0	187.13	2254.2	602.44	2254.2	9.99+	3.74
145	15	S2	0	12.13	2517.16	1498.82	2517.16	9.99+	1.68
146	15	S3	0	0	2525.25	1299.36	2525.25	9.99+	1.94
147	15	S4	0	2	2524.55	1336.17	2524.55	9.99+	1.89
148	15	S5	0	0.62	2524.89	1329.43	2524.89	9.99+	1.9
149	15	S6	0	0	2524.74	1330.92	2524.74	9.99+	1.9
150	15	S7	0	0.62	2524.9	1329.47	2524.9	9.99+	1.9
151	15	S8	0	2	2524.55	1336.24	2524.55	9.99+	1.89
152	15	S9	0	0	2525.26	1299.38	2525.26	9.99+	1.94
153	15	S10	0	12.12	2517.14	1498.74	2517.14	9.99+	1.68
154	15	S11	0	187.13	2254.22	602.5	2254.22	9.99+	3.74



JOB NO.: U2716.0386.241

**PROJECT:** Sunturf Package A17 Ground Mount

---

# ANCHORAGE DESIGN FOR CONCRETE BALLAST BLOCK

**Load Combinations**

	Description	Solve	P-Delta	BLC	Factor	BLC	Factor	BLC	Factor	BLC	Factor
1	ASD Loads		Y								
2	1.0 D		Y	DL	1						
3	1.0 D + 1.0 S		Y	DL	1	RLL	1				
4	1.0 D + 0.6 W1		Y	DL	1	RLL		OL1	0.6	WLZ	0.6
5	1.0 D + 0.6 W2		Y	DL	1	RLL		OL2	0.6	WLZ	0.6
6	1.0 D + 0.6 W3		Y	DL	1	RLL		OL3	0.6	WLZ	-0.6
7	1.0 D + 0.6 W4		Y	DL	1	RLL		OL4	0.6	WLZ	-0.6
8	1.0 D + 0.45 W1 + 0.75 S		Y	DL	1	RLL	0.75	OL1	0.45	WLZ	0.45
9	1.0 D + 0.45 W2 + 0.75 S		Y	DL	1	RLL	0.75	OL2	0.45	WLZ	0.45
10	1.0 D + 0.45 W3 + 0.75 S		Y	DL	1	RLL	0.75	OL3	0.45	WLZ	-0.45
11	1.0 D + 0.45 W4 + 0.75 S		Y	DL	1	RLL	0.75	OL4	0.45	WLZ	-0.45
12	0.6 D + 0.6 W1		Y	DL	0.6	RLL		OL1	0.6	WLZ	0.6
13	0.6 D + 0.6 W2		Y	DL	0.6	RLL		OL2	0.6	WLZ	0.6
14	0.6 D + 0.6 W3		Y	DL	0.6	RLL		OL3	0.6	WLZ	-0.6
15	0.6 D + 0.6 W4		Y	DL	0.6	RLL		OL4	0.6	WLZ	-0.6
16			Y								
17	LRFD Loads		Y								
18	1.4 D	Yes	Y	DL	1.4	RLL					
19	1.2 D + 1.6 S + 0.5 W1	Yes	Y	DL	1.2	RLL	1.6	OL1	0.5		
20	1.2 D + 1.6 S + 0.5 W2	Yes	Y	DL	1.2	RLL	1.6	OL2	0.5		
21	1.2 D + 1.6 S + 0.5 W3	Yes	Y	DL	1.2	RLL	1.6	OL3	0.5		
22	1.2 D + 1.6 S + 0.5 W4	Yes	Y	DL	1.2	RLL	1.6	OL4	0.5		
23	1.2 D + 1.0 W1	Yes	Y	DL	1.2	RLL		OL1	1		
24	1.2 D + 1.0 W2	Yes	Y	DL	1.2	RLL		OL2	1		
25	1.2 D + 1.0 W3	Yes	Y	DL	1.2	RLL		OL3	1		
26	1.2 D + 1.0 W4	Yes	Y	DL	1.2	RLL		OL4	1		
27	0.9 D + 1.0 W1	Yes	Y	DL	0.9	RLL		OL1	1		
28	0.9 D + 1.0 W2	Yes	Y	DL	0.9	RLL		OL2	1		
29	0.9 D + 1.0 W3	Yes	Y	DL	0.9	RLL		OL3	1		
30	0.9 D + 1.0 W4	Yes	Y	DL	0.9	RLL		OL4	1		

**Envelope Node Reactions**

Node Label	X [lb]	LC	Y [lb]	LC	Z [lb]	LC	MX [lb-ft]	LC	MY [lb-ft]	LC	MZ [lb-ft]	LC
1 N2 max	190.44	22	2205.51	20	103.99	23	0	30	0	30	0	30
2 min	-26.63	27	-313.07	29	-123.18	25	0	18	0	18	0	18
3 N1 max	707.24	21	3866.98	21	1234.63	25	0	30	0	30	0	30
4 min	-344.56	28	-2311.92	28	-1060.48	23	0	18	0	18	0	18
5 N151 max	344.57	28	3866.99	21	1234.74	25	0	30	0	30	0	30
6 min	-707.22	21	-2312.04	28	-1060.58	23	0	18	0	18	0	18
7 N152 max	26.62	27	2205.51	20	104	23	0	30	0	30	0	30
8 min	-190.44	22	-313.21	29	-123.19	25	0	18	0	18	0	18
9 N305 max	10.03	28	5272.48	21	2949.79	25	0	30	0	30	0	30
10 min	-17.29	21	-3696.57	28	-2531.48	23	0	18	0	18	0	18
11 N309 max	37.78	22	4834.65	20	166.09	23	0	30	0	30	0	30
12 min	-14.78	27	-817.48	29	-188.81	25	0	18	0	18	0	18
13 N230 max	3.64	21	5966.26	21	2583.54	25	0	30	0	30	0	30
14 min	-1.96	28	-3883.39	28	-2217.65	23	0	18	0	18	0	18
15 N235 max	2.18	29	4383.32	20	167.07	23	0	30	0	30	0	30
16 min	-5.47	20	-683.6	29	-193.01	25	0	18	0	18	0	18
17 N239 max	0.63	24	5864	21	2658.63	25	0	30	0	30	0	30
18 min	-1	25	-3861.68	28	-2282.27	23	0	18	0	18	0	18
19 N241 max	4.14	25	4469.11	20	170.19	23	0	30	0	30	0	30
20 min	-3.26	27	-709.74	29	-196.33	25	0	18	0	18	0	18
21 N245 max	0.31	20	5885.87	21	2645.39	25	0	30	0	30	0	30

**Envelope Node Reactions (Continued)**

Node Label		X [lb]	LC	Y [lb]	LC	Z [lb]	LC	MX [lb-ft]	LC	MY [lb-ft]	LC	MZ [lb-ft]	LC
22		min		-0.1	29	-3868.32	28	-2270.87	23	0	18	0	18
23	N247	max		1.62	25	4454.85	20	170.43	23	0	30	0	30
24		min		-1.5	28	-706.53	29	-196.73	25	0	18	0	18
25	N251	max		0	19	5879.99	21	2648.59	25	0	30	0	30
26		min		0	21	-3865.89	28	-2273.59	23	0	18	0	18
27	N253	max		0	25	4457.61	20	170.57	23	0	30	0	30
28		min		0	19	-706.73	29	-196.9	25	0	18	0	18
29	N257	max		0.1	29	5885.8	21	2645.37	25	0	30	0	30
30		min		-0.31	20	-3868.27	28	-2270.86	23	0	18	0	18
31	N259	max		1.51	28	4454.84	20	170.43	23	0	30	0	30
32		min		-1.61	25	-706.51	29	-196.73	25	0	18	0	18
33	N263	max		1	25	5863.97	21	2658.62	25	0	30	0	30
34		min		-0.63	24	-3861.65	28	-2282.26	23	0	18	0	18
35	N265	max		3.26	27	4469.1	20	170.19	23	0	30	0	30
36		min		-4.14	25	-709.72	29	-196.33	25	0	18	0	18
37	N269	max		1.96	28	5966.22	21	2583.48	25	0	30	0	30
38		min		-3.64	21	-3883.33	28	-2217.6	23	0	18	0	18
39	N271	max		5.47	20	4383.31	20	167.07	23	0	30	0	30
40		min		-2.18	29	-683.55	29	-193	25	0	18	0	18
41	N276	max		17.29	21	5272.27	21	2949.77	25	0	30	0	30
42		min		-10.03	28	-3696.47	28	-2531.46	23	0	18	0	18
43	N278	max		14.79	27	4834.5	20	166.08	23	0	30	0	30
44		min		-37.78	22	-817.24	29	-188.8	25	0	18	0	18
45	Totals:	max		0	22	91867.96	21	24799.53	25				
46		min		0	27	-26426.52	27	-21272.98	27				



Anchor Designer™  
Software  
Version 3.0.7947.0

Company:	Vector Structural Engineers	Date:	3/17/2022
Engineer:	MIH	Page:	1/6
Project:	Sunturf Ground Mount A17		
Address:			
Phone:			
E-mail:			

### 1. Project information

Customer company: SunModo  
Customer contact name:  
Customer e-mail:  
Comment:

Project description:  
Location:  
Fastening description: Anchorage to concrete ballast block

### 2. Input Data & Anchor Parameters

#### General

Design method: ACI 318-14  
Units: Imperial units

#### Anchor Information:

Anchor type: Bonded anchor  
Material: F593 304/316SS  
Diameter (inch): 0.375  
Effective Embedment depth,  $h_{ef}$  (inch): 6.000  
Code report: ICC-ES ESR-4057  
Anchor category: -  
Anchor ductility: Yes  
 $h_{min}$  (inch): 7.25  
 $c_{ac}$  (inch): 10.99  
 $C_{min}$  (inch): 1.75  
 $S_{min}$  (inch): 1.00

#### Base Material

Concrete: Normal-weight  
Concrete thickness,  $h$  (inch): 24.00  
State: Cracked  
Compressive strength,  $f'_c$  (psi): 2500  
 $\Psi_{c,v}$ : 1.0  
Reinforcement condition: B tension, B shear  
Supplemental reinforcement: Not applicable  
Reinforcement provided at corners: No  
Ignore concrete breakout in tension: No  
Ignore concrete breakout in shear: No  
Hole condition: Dry concrete  
Inspection: Periodic  
Temperature range, Short/Long: 150/110°F  
Ignore 6do requirement: Not applicable  
Build-up grout pad: No

#### Base Plate

Length x Width x Thickness (inch): 4.75 x 4.75 x 0.31

#### Recommended Anchor

Anchor Name: SET-3G - SET-3G w/ 3/8"Ø F593 CW (304/316SS)  
Code Report: ICC-ES ESR-4057





Company:	Vector Structural Engineers	Date:	3/17/2022
Engineer:	MIH	Page:	2/6
Project:	Sunturf Ground Mount A17		
Address:			
Phone:			
E-mail:			

**Load and Geometry**

Load factor source: ACI 318 Section 5.3

Load combination: not set

Seismic design: No

Anchors subjected to sustained tension: No

Apply entire shear load at front row: No

Anchors only resisting wind and/or seismic loads: No

Strength level loads:

$N_{ua}$  [lb]: 3884

$V_{uax}$  [lb]: 708

$V_{uay}$  [lb]: -2950

$M_{ux}$  [ft-lb]: 0

$M_{uy}$  [ft-lb]: 0

$M_{uz}$  [ft-lb]: 0

<Figure 1>

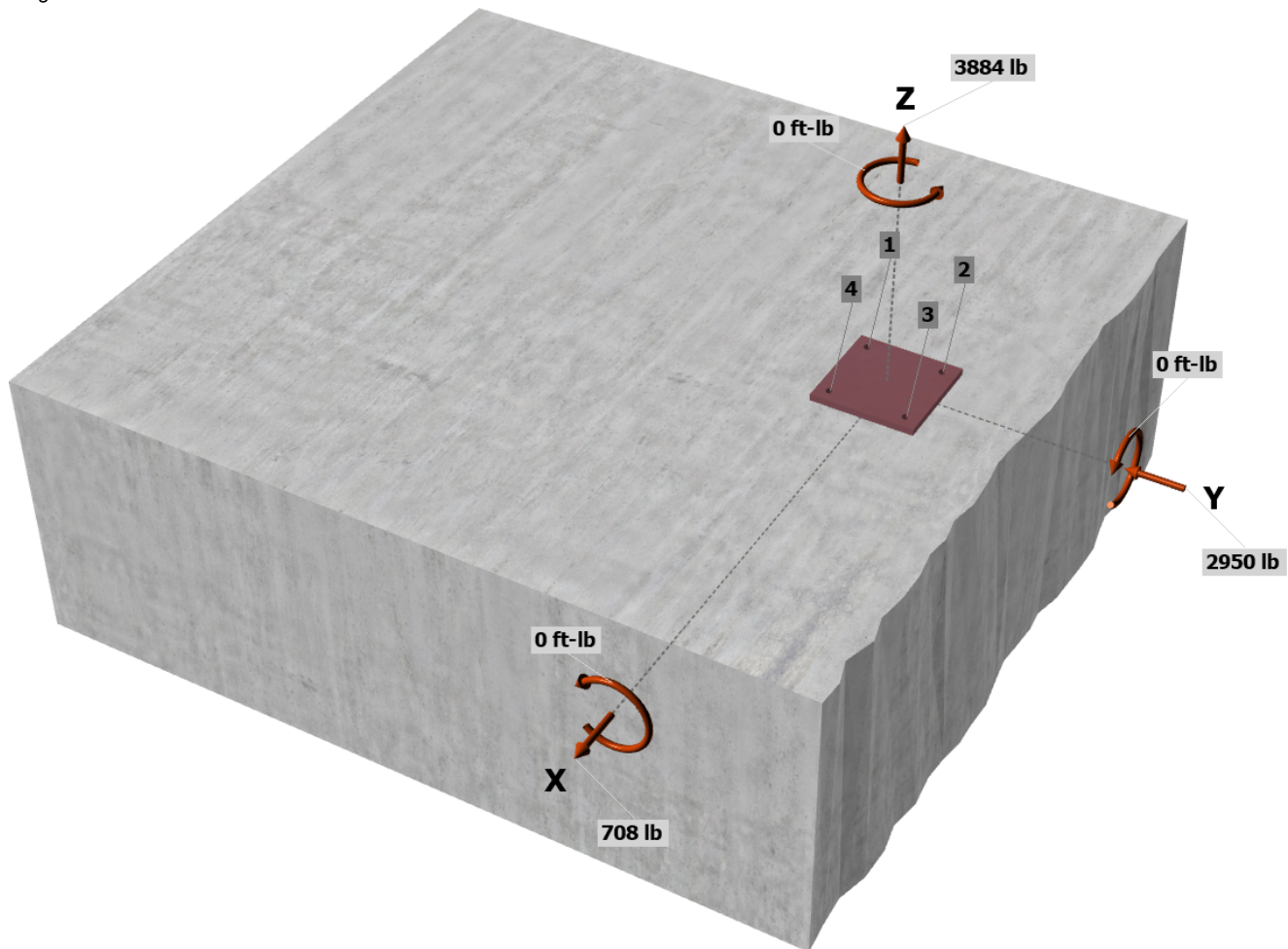

Input data and results must be checked for agreement with the existing circumstances, the standards and guidelines must be checked for plausibility.





Company:	Vector Structural Engineers	Date:	3/17/2022
Engineer:	MIH	Page:	3/6
Project:	Sunturf Ground Mount A17		
Address:			
Phone:			
E-mail:			

<Figure 2>

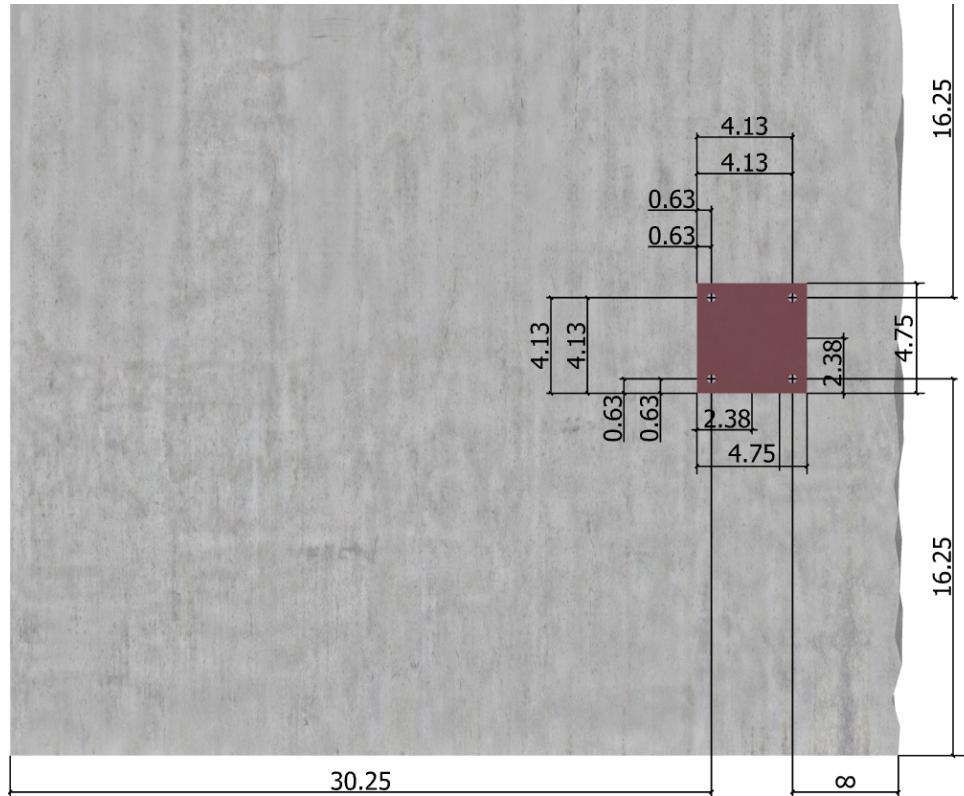





Company:	Vector Structural Engineers	Date:	3/17/2022
Engineer:	MIH	Page:	4/6
Project:	Sunturf Ground Mount A17		
Address:			
Phone:			
E-mail:			

### 3. Resulting Anchor Forces

Anchor	Tension load, $N_{ua}$ (lb)	Shear load x, $V_{uax}$ (lb)	Shear load y, $V_{uay}$ (lb)	Shear load combined, $\sqrt{(V_{uax})^2 + (V_{uay})^2}$ (lb)
1	971.0	177.0	-737.5	758.5
2	971.0	177.0	-737.5	758.5
3	971.0	177.0	-737.5	758.4
4	971.0	177.0	-737.5	758.4
Sum	3884.0	708.0	-2950.0	3033.8

Maximum concrete compression strain (%): 0.00  
 Maximum concrete compression stress (psi): 0  
 Resultant tension force (lb): 3884  
 Resultant compression force (lb): 0  
 Eccentricity of resultant tension forces in x-axis,  $e'_{Nx}$  (inch): 0.00  
 Eccentricity of resultant tension forces in y-axis,  $e'_{Ny}$  (inch): 0.00  
 Eccentricity of resultant shear forces in x-axis,  $e'_{Vx}$  (inch): 0.00  
 Eccentricity of resultant shear forces in y-axis,  $e'_{Vy}$  (inch): 0.00

<Figure 3>

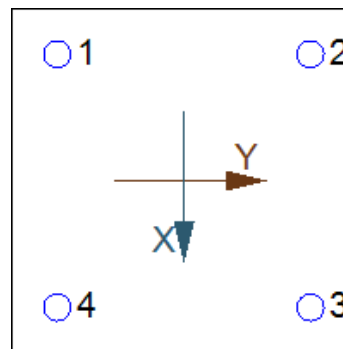

### 4. Steel Strength of Anchor in Tension (Sec. 17.4.1)

$N_{sa}$ (lb)	$\phi$	$\phi N_{sa}$ (lb)
7800	0.75	5850

### 5. Concrete Breakout Strength of Anchor in Tension (Sec. 17.4.2)

$$N_b = K_c \lambda_a \sqrt{f'_c} c_{hef}^{1.5} \text{ (Eq. 17.4.2.2a)}$$

$K_c$	$\lambda_a$	$f'_c$ (psi)	$h_{ef}$ (in)	$N_b$ (lb)
17.0	1.00	2500	6.000	12492

$$\phi N_{cbg} = \phi (A_{Nc} / A_{Nco}) \Psi_{ec,N} \Psi_{ed,N} \Psi_{c,N} \Psi_{cp,N} N_b \text{ (Sec. 17.3.1 \& Eq. 17.4.2.1b)}$$

$A_{Nc}$ (in <sup>2</sup> )	$A_{Nco}$ (in <sup>2</sup> )	$C_{a,min}$ (in)	$\Psi_{ec,N}$	$\Psi_{ed,N}$	$\Psi_{c,N}$	$\Psi_{cp,N}$	$N_b$ (lb)	$\phi$	$\phi N_{cbg}$ (lb)
462.25	324.00	16.25	1.000	1.000	1.00	1.000	12492	0.65	11585

### 6. Adhesive Strength of Anchor in Tension (Sec. 17.4.5)

$$\tau_{k,cr} = \tau_{k,cr,short-term} K_{sat} (f'_c / 2,500)^0$$

$\tau_{k,cr}$ (psi)	$f_{short-term}$	$K_{sat}$	$f'_c$ (psi)	$n$	$\tau_{k,cr}$ (psi)
1346	1.00	1.00	2500	0.24	1346

$$N_{ba} = \lambda_a \tau_{cr} \pi d_a h_{ef} \text{ (Eq. 17.4.5.2)}$$

$\lambda_a$	$\tau_{cr}$ (psi)	$d_a$ (in)	$h_{ef}$ (in)	$N_{ba}$ (lb)
1.00	1346	0.38	6.000	9514

$$\phi N_{ag} = \phi (A_{Na} / A_{Na0}) \Psi_{ec,Na} \Psi_{ed,Na} \Psi_{cp,Na} N_{ba} \text{ (Sec. 17.3.1 \& Eq. 17.4.5.1b)}$$

$A_{Na}$ (in <sup>2</sup> )	$A_{Na0}$ (in <sup>2</sup> )	$C_{Na}$ (in)	$C_{a,min}$ (in)	$\Psi_{ec,Na}$	$\Psi_{ed,Na}$	$\Psi_{cp,Na}$	$N_{ba}$ (lb)	$\phi$	$\phi N_{ag}$ (lb)
198.45	112.09	5.29	16.25	1.000	1.000	1.000	9514	0.55	9265



**Anchor Designer™**  
**Software**  
 Version 3.0.7947.0

Company:	Vector Structural Engineers	Date:	3/17/2022
Engineer:	MIH	Page:	5/6
Project:	Sunturf Ground Mount A17		
Address:			
Phone:			
E-mail:			

**8. Steel Strength of Anchor in Shear (Sec. 17.5.1)**

$V_{sa}$ (lb)	$\phi_{grout}$	$\phi$	$\phi_{grout}\phi V_{sa}$ (lb)
4680	1.0	0.65	3042

**9. Concrete Breakout Strength of Anchor in Shear (Sec. 17.5.2)**

**Shear perpendicular to edge in x-direction:**

$V_{bx} = \min|7(l_e / d_a)^{0.2} \sqrt{d_a} \lambda_a \sqrt{f_c} c_{a1}^{1.5}; 9 \lambda_a \sqrt{f_c} c_{a1}^{1.5}|$  (Eq. 17.5.2.2a & Eq. 17.5.2.2b)

$l_e$ (in)	$d_a$ (in)	$\lambda_a$	$f_c$ (psi)	$c_{a1}$ (in)	$V_{bx}$ (lb)
3.00	0.375	1.00	2500	19.75	28514

$\phi V_{cbgx} = \phi (A_{vc} / A_{vco}) \Psi_{ec,v} \Psi_{ed,v} \Psi_{c,v} \Psi_{h,v} V_{bx}$  (Sec. 17.3.1 & Eq. 17.5.2.1b)

$A_{vc}$ (in <sup>2</sup> )	$A_{vco}$ (in <sup>2</sup> )	$\Psi_{ec,v}$	$\Psi_{ed,v}$	$\Psi_{c,v}$	$\Psi_{h,v}$	$V_{bx}$ (lb)	$\phi$	$\phi V_{cbgx}$ (lb)
1506.00	1755.28	1.000	1.000	1.000	1.111	28514	0.70	19026

**Shear perpendicular to edge in y-direction:**

$V_{by} = \min|7(l_e / d_a)^{0.2} \sqrt{d_a} \lambda_a \sqrt{f_c} c_{a1}^{1.5}; 9 \lambda_a \sqrt{f_c} c_{a1}^{1.5}|$  (Eq. 17.5.2.2a & Eq. 17.5.2.2b)

$l_e$ (in)	$d_a$ (in)	$\lambda_a$	$f_c$ (psi)	$c_{a1}$ (in)	$V_{by}$ (lb)
3.00	0.375	1.00	2500	16.00	20791

$\phi V_{cbgy} = \phi (A_{vc} / A_{vco}) \Psi_{ec,v} \Psi_{ed,v} \Psi_{c,v} \Psi_{h,v} V_{by}$  (Sec. 17.3.1 & Eq. 17.5.2.1b)

$A_{vc}$ (in <sup>2</sup> )	$A_{vco}$ (in <sup>2</sup> )	$\Psi_{ec,v}$	$\Psi_{ed,v}$	$\Psi_{c,v}$	$\Psi_{h,v}$	$V_{by}$ (lb)	$\phi$	$\phi V_{cbgy}$ (lb)
864.00	1152.00	1.000	0.903	1.000	1.000	20791	0.70	9858

**Shear parallel to edge in y-direction:**

$V_{bx} = \min|7(l_e / d_a)^{0.2} \sqrt{d_a} \lambda_a \sqrt{f_c} c_{a1}^{1.5}; 9 \lambda_a \sqrt{f_c} c_{a1}^{1.5}|$  (Eq. 17.5.2.2a & Eq. 17.5.2.2b)

$l_e$ (in)	$d_a$ (in)	$\lambda_a$	$f_c$ (psi)	$c_{a1}$ (in)	$V_{bx}$ (lb)
3.00	0.375	1.00	2500	16.00	20791

$\phi V_{cbgy} = \phi (2)(A_{vc} / A_{vco}) \Psi_{ec,v} \Psi_{ed,v} \Psi_{c,v} \Psi_{h,v} V_{bx}$  (Sec. 17.3.1, 17.5.2.1(c) & Eq. 17.5.2.1b)

$A_{vc}$ (in <sup>2</sup> )	$A_{vco}$ (in <sup>2</sup> )	$\Psi_{ec,v}$	$\Psi_{ed,v}$	$\Psi_{c,v}$	$\Psi_{h,v}$	$V_{bx}$ (lb)	$\phi$	$\phi V_{cbgy}$ (lb)
864.00	1152.00	1.000	1.000	1.000	1.000	20791	0.70	21831

**Shear parallel to edge in x-direction:**

$V_{by} = \min|7(l_e / d_a)^{0.2} \sqrt{d_a} \lambda_a \sqrt{f_c} c_{a1}^{1.5}; 9 \lambda_a \sqrt{f_c} c_{a1}^{1.5}|$  (Eq. 17.5.2.2a & Eq. 17.5.2.2b)

$l_e$ (in)	$d_a$ (in)	$\lambda_a$	$f_c$ (psi)	$c_{a1}$ (in)	$V_{by}$ (lb)
3.00	0.375	1.00	2500	16.25	21280

$\phi V_{cbgx} = \phi (2)(A_{vc} / A_{vco}) \Psi_{ec,v} \Psi_{ed,v} \Psi_{c,v} \Psi_{h,v} V_{by}$  (Sec. 17.3.1, 17.5.2.1(c) & Eq. 17.5.2.1b)

$A_{vc}$ (in <sup>2</sup> )	$A_{vco}$ (in <sup>2</sup> )	$\Psi_{ec,v}$	$\Psi_{ed,v}$	$\Psi_{c,v}$	$\Psi_{h,v}$	$V_{by}$ (lb)	$\phi$	$\phi V_{cbgx}$ (lb)
1254.00	1188.28	1.000	1.000	1.000	1.008	21280	0.70	31685

**10. Concrete Pryout Strength of Anchor in Shear (Sec. 17.5.3)**

$\phi V_{cp} = \phi \min|k_{cp} N_{ag}; k_{cp} N_{cb}| = \phi \min|k_{cp} (A_{Na} / A_{Na0}) \Psi_{ec,Na} \Psi_{ed,Na} \Psi_{c,Na} N_{ba}; k_{cp} (A_{Nc} / A_{Nco}) \Psi_{ec,N} \Psi_{ed,N} \Psi_{c,N} \Psi_{cp,N} N_b|$  (Sec. 17.3.1 & Eq. 17.5.3.1b)

$k_{cp}$	$A_{Na}$ (in <sup>2</sup> )	$A_{Na0}$ (in <sup>2</sup> )	$\Psi_{ed,Na}$	$\Psi_{ec,Na}$	$\Psi_{c,Na}$	$N_{ba}$ (lb)	$N_a$ (lb)
2.0	198.45	112.09	1.000	1.000	1.000	9514	16844

$A_{Nc}$ (in <sup>2</sup> )	$A_{Nco}$ (in <sup>2</sup> )	$\Psi_{ec,N}$	$\Psi_{ed,N}$	$\Psi_{c,N}$	$\Psi_{cp,N}$	$N_b$ (lb)	$N_{cb}$ (lb)	$\phi$
462.25	324.00	1.000	1.000	1.000	1.000	12492	17823	0.70

Input data and results must be checked for agreement with the existing circumstances, the standards and guidelines must be checked for plausibility.



Anchor Designer™  
Software  
Version 3.0.7947.0

Company:	Vector Structural Engineers	Date:	3/17/2022
Engineer:	MIH	Page:	6/6
Project:	Sunturf Ground Mount A17		
Address:			
Phone:			
E-mail:			

$\phi V_{cpg}$  (lb)  
23582

## 11. Results

### Interaction of Tensile and Shear Forces (Sec. 17.6.)

Tension	Factored Load, $N_{ua}$ (lb)	Design Strength, $\phi N_n$ (lb)	Ratio	Status	
Steel	971	5850	0.17	Pass	
Concrete breakout	3884	11585	0.34	Pass	
<b>Adhesive</b>	<b>3884</b>	<b>9265</b>	<b>0.42</b>	<b>Pass (Governs)</b>	
Shear	Factored Load, $V_{ua}$ (lb)	Design Strength, $\phi V_n$ (lb)	Ratio	Status	
Steel	758	3042	0.25	Pass	
T Concrete breakout x+	708	19026	0.04	Pass	
T Concrete breakout y-	2950	9858	0.30	Pass	
Concrete breakout y-	354	21831	0.02	Pass	
Concrete breakout x-	1475	31685	0.05	Pass	
<b>Concrete breakout, combined</b>	<b>-</b>	<b>-</b>	<b>0.30</b>	<b>Pass (Governs)</b>	
Pryout	3034	23582	0.13	Pass	
Interaction check	$N_{ua}/\phi N_n$	$V_{ua}/\phi V_n$	Combined Ratio	Permissible	Status
Sec. 17.6..1	0.42	0.00	41.9%	1.0	Pass

SET-3G w/ 3/8"Ø F593 CW (304/316SS) with hef = 6.000 inch meets the selected design criteria.

## 12. Warnings

- Designer must exercise own judgement to determine if this design is suitable.
- Refer to manufacturer's product literature for hole cleaning and installation instructions.