



Project Number: U2716-0277-211

May 20, 2024

Sunmodo
14800 NE 65th Street
Vancouver, WA 98682

**REFERENCE: Sunmodo Sunturf Ground Mount D3 – Large Format Panels
Ground Mount PV Array Installation**

To Whom It May Concern:

Per request of Sunmodo, we have been asked to prepare the structural design of a ground-mounted PV solar array system with several foundation options as shown in the attached calculations. The adopted building code in this jurisdiction is the International Building Code, 2021 Edition (2021 IBC). Vector Structural Engineering requires that we review each site-specific install, and we are not liable for installs at site specific locations we have not reviewed. This document does not address site-specific installations. The following design parameters are used in our analysis:

- Minimum Design Loads for Buildings and Other Structures (ASCE 7-16)
- Design wind speed for risk category I structures: 170 mph
- Wind exposure: C
- Ground snow load: 0 psf
- The ground screws and helical piers must be tested to 1.5 times uplift and 2.0 times lateral reactions found in the table below. A minimum of one ground screw or helical pier must be tested.

Load (ASD)	Value (lbs)	Factor of Safety	Test Value (lbs)
UPLIFT	2461	1.5	3692
LATERAL	1217	2	2434

Foundation concrete shall have a minimum compressive strength of 2500 psi at 28 days. Cement for all concrete shall be Type I or II with a water/cement ratio of 0.50. Maximum aggregate size shall be 3/4". No special inspection of concrete strength is required.

Footings are designed based on an allowable soil bearing pressure of 1500 psf an allowable skin friction of 250 psf, an allowable lateral bearing pressure of 150 pcf, and a coefficient of friction of 0.3. Vector Structural Engineering strongly recommends independent soils testing be performed by a licensed geotechnical engineer to verify the assumed soil parameters.

All ground mounts are to be installed per manufacturer’s recommendations. The use of solar panel support span tables provided by the manufacturer is allowed only where the site conditions and solar panel configuration match the description of the span tables. Electrical engineering is beyond our scope. All work performed must be in accordance with accepted industry-wide methods and applicable safety standards. Vector Structural Engineering assumes no responsibility for improper installation of the solar panels.

Very truly yours,

VECTOR STRUCTURAL ENGINEERING, LLC
CO Firm License: 2018009799

Eric Sumsion, P.E.
License: 56167 - Expires: 10/31/2025
Project Engineer

Enclosures

ESS/mih





JOB NO. U2716-0277-211
 PROJECT SUNMODO SUNTURF GROUND MOUNTS D3
 SUBJECT ALL OPTIONS

651 W GALENA PARK BLVD. #101 (801) 990-1775
 DRAPER, UTAH 84020 (801) 990-1776 FAX



Vector Structural Engineering requires that we review each site-specific install, and we are not liable for installs at site-specific locations we have not reviewed. This document does not address site-specific installations.

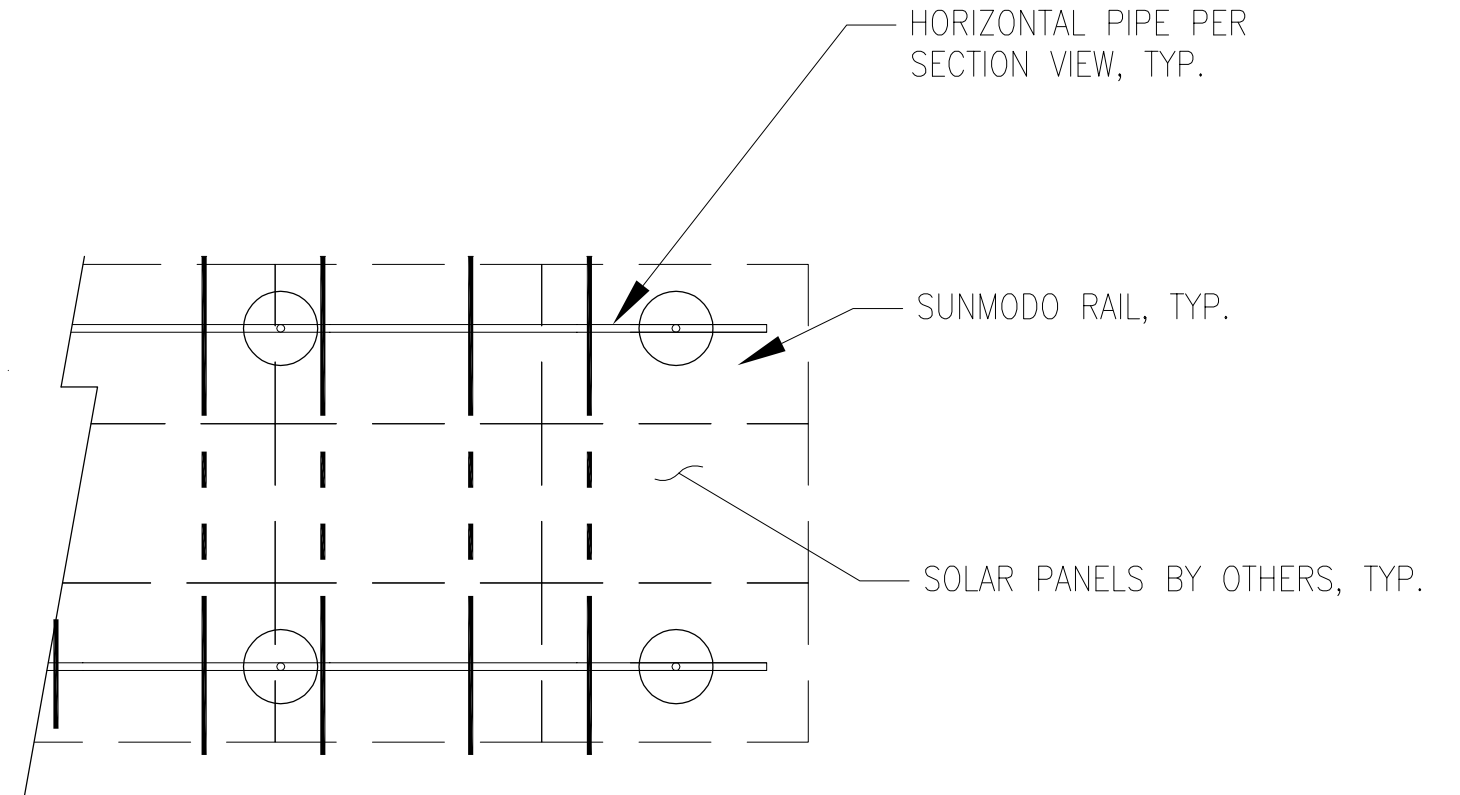
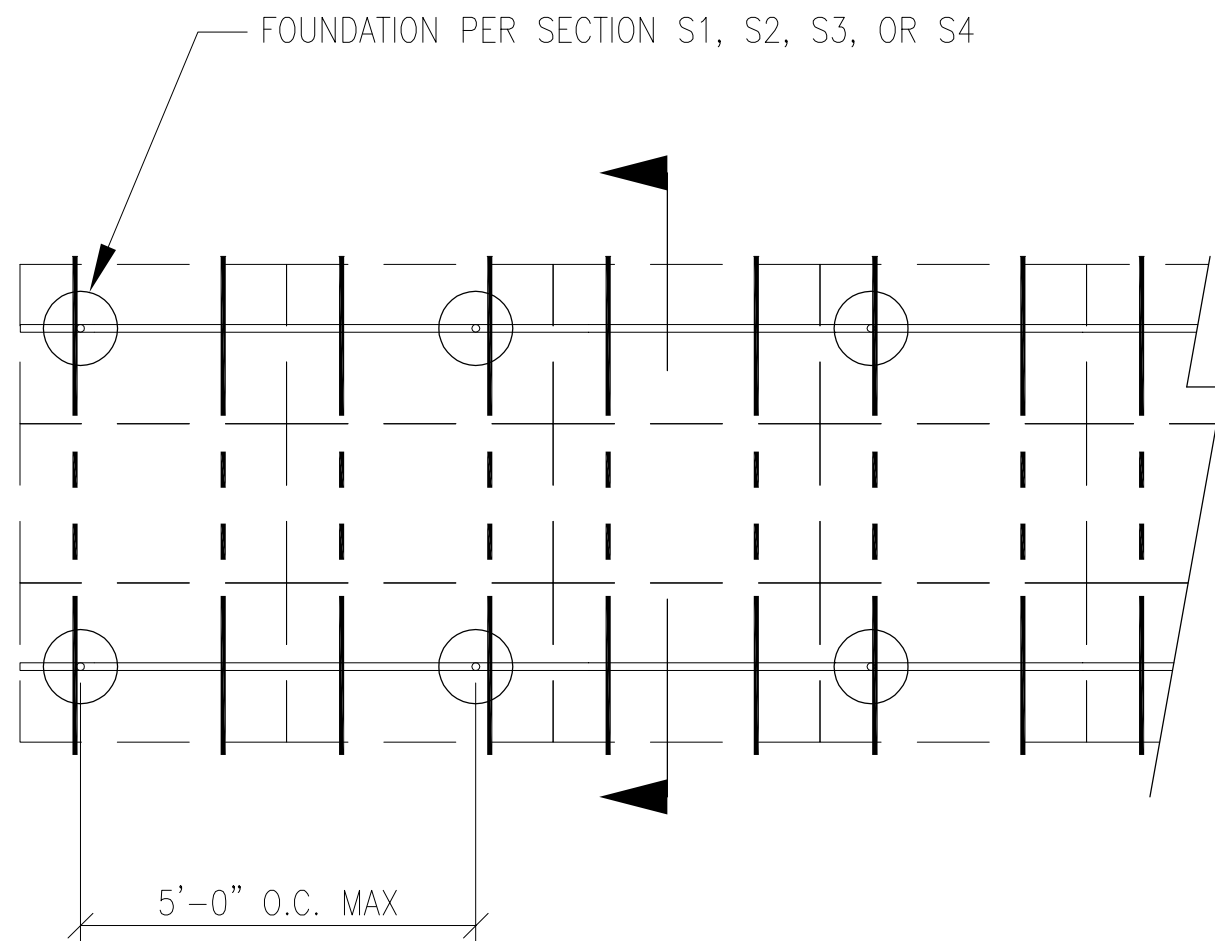

PV ARRAY PLAN

N.T.S.

P1

PROJECT SUNMODO SUNTURF GROUND MOUNTS D3

SUBJECT DRILLED PIER OPTION

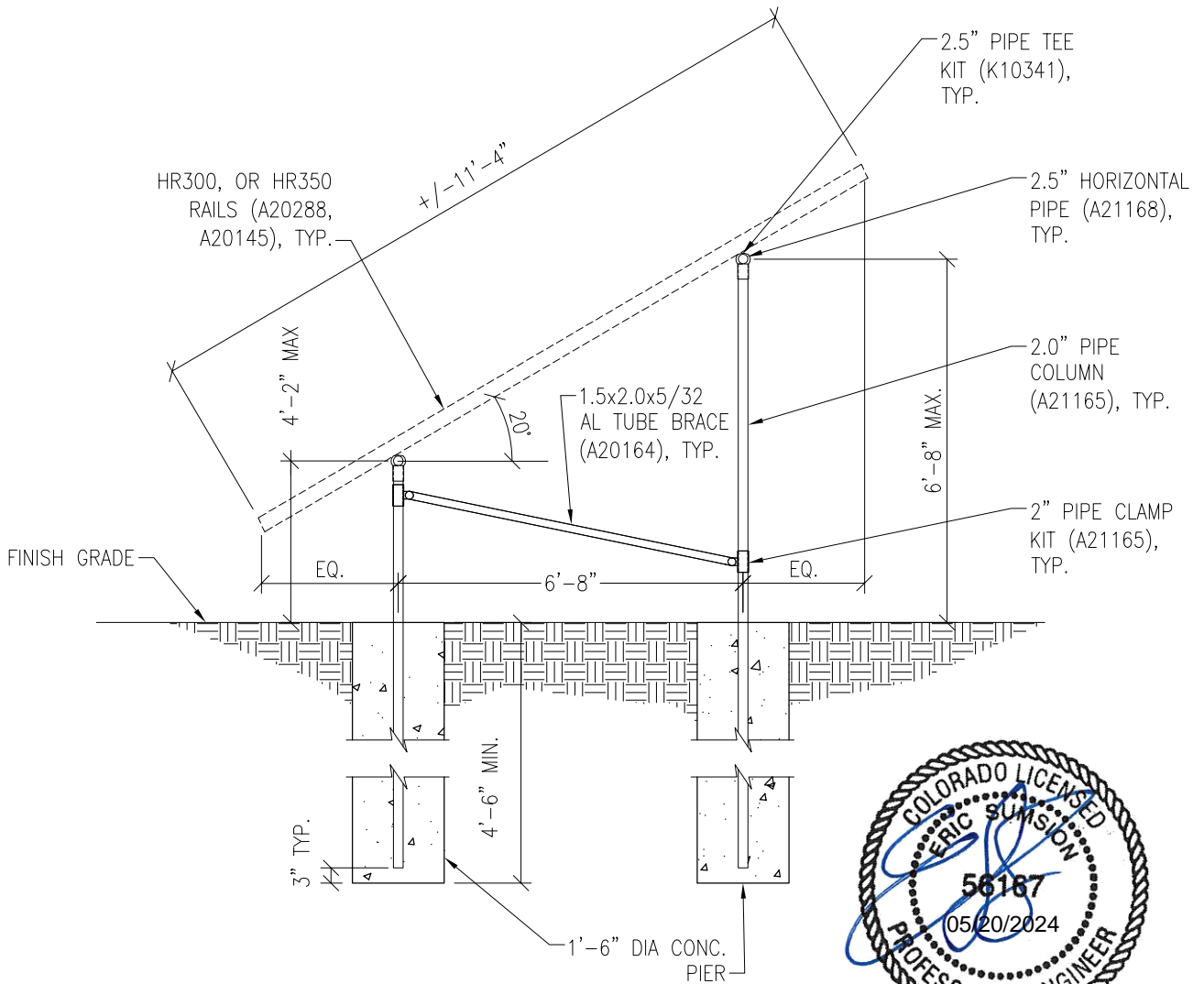

Vector Structural Engineering requires that we review each site-specific install, and we are not liable for installs at site-specific locations we have not reviewed. This document does not address site-specific installations.

PV ARRAY SECTION

N.T.S.

S1

PROJECT SUNMODO SUNTURF GROUND MOUNTS D3

SUBJECT HELICAL PIER OPTION

NOTES:

1. For ground mount components see Section S1.
2. A minimum of (1) helical pier must be load-tested as follows:
 - 2.1. Safety factor for uplift = 1.5,
 - 2.2. Safety factor for lateral loads = 2.0
 - 2.3. Upward deflection limit = 1/2"
 - 2.4. Lateral deflection limit = 1"
 - 2.5. The load tests must be performed by an approved contractor.

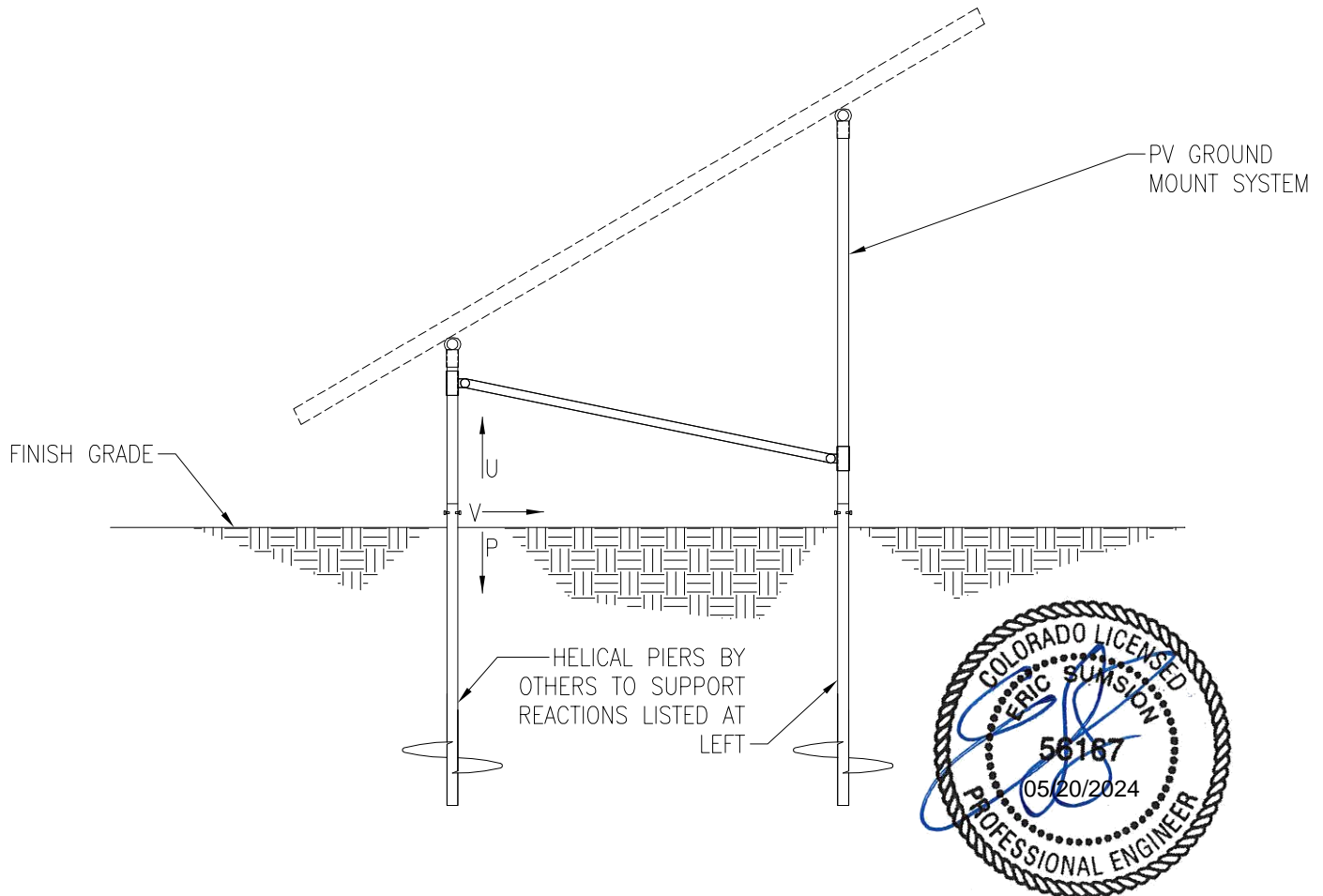

Vector Structural Engineering requires that we review each site-specific install, and we are not liable for installs at site-specific locations we have not reviewed. This document does not address site-specific installations.

PV ARRAY SECTION

N.T.S.

S2

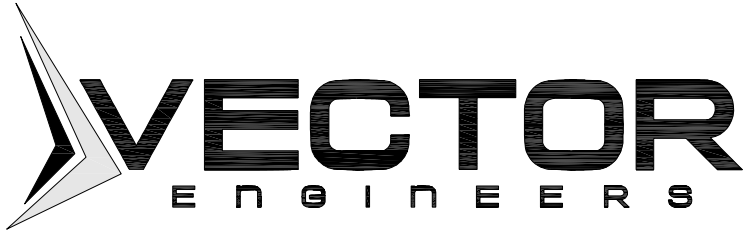

JOB NO. U2716-0277-211

PROJECT SUNMODO SUNTURF GROUND MOUNTS D3

SUBJECT GROUND SCREW OPTION

NOTES:

1. For ground mount components see Section S1.
2. A minimum of (1) ground screw must be load-tested as follows:
 - 2.1. Safety factor for uplift = 1.5,
 - 2.2. Safety factor for lateral loads = 2.0
 - 2.3. Upward deflection limit = 1/2"
 - 2.4. Lateral deflection limit = 1"
 - 2.5. The load tests must be performed by an approved contractor.

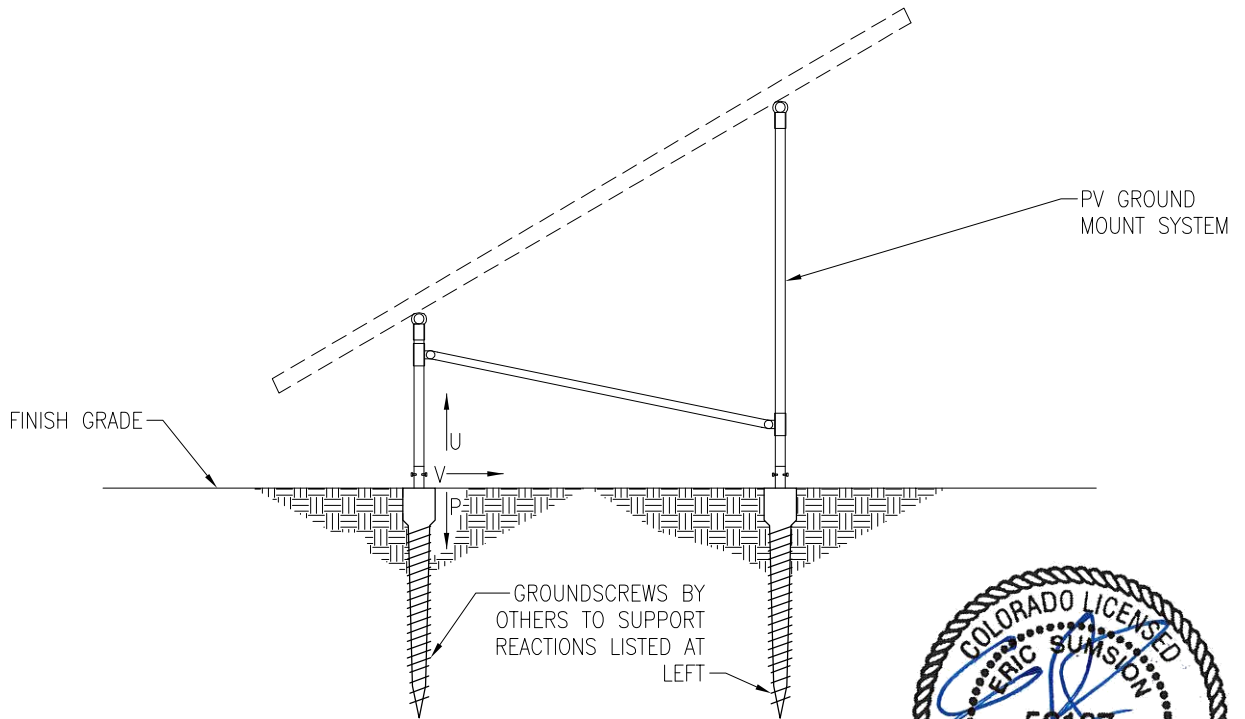

Vector Structural Engineering requires that we review each site-specific install, and we are not liable for installs at site-specific locations we have not reviewed. This document does not address site-specific installations.



PV ARRAY SECTION

N.T.S.

S3



JOB NO. U2716-0277-211

PROJECT SUNMODO SUNTURF GROUND MOUNTS D3

SUBJECT BALLASTED BLOCK OPTION

NOTES:

1. For ground mount components see Section S1.

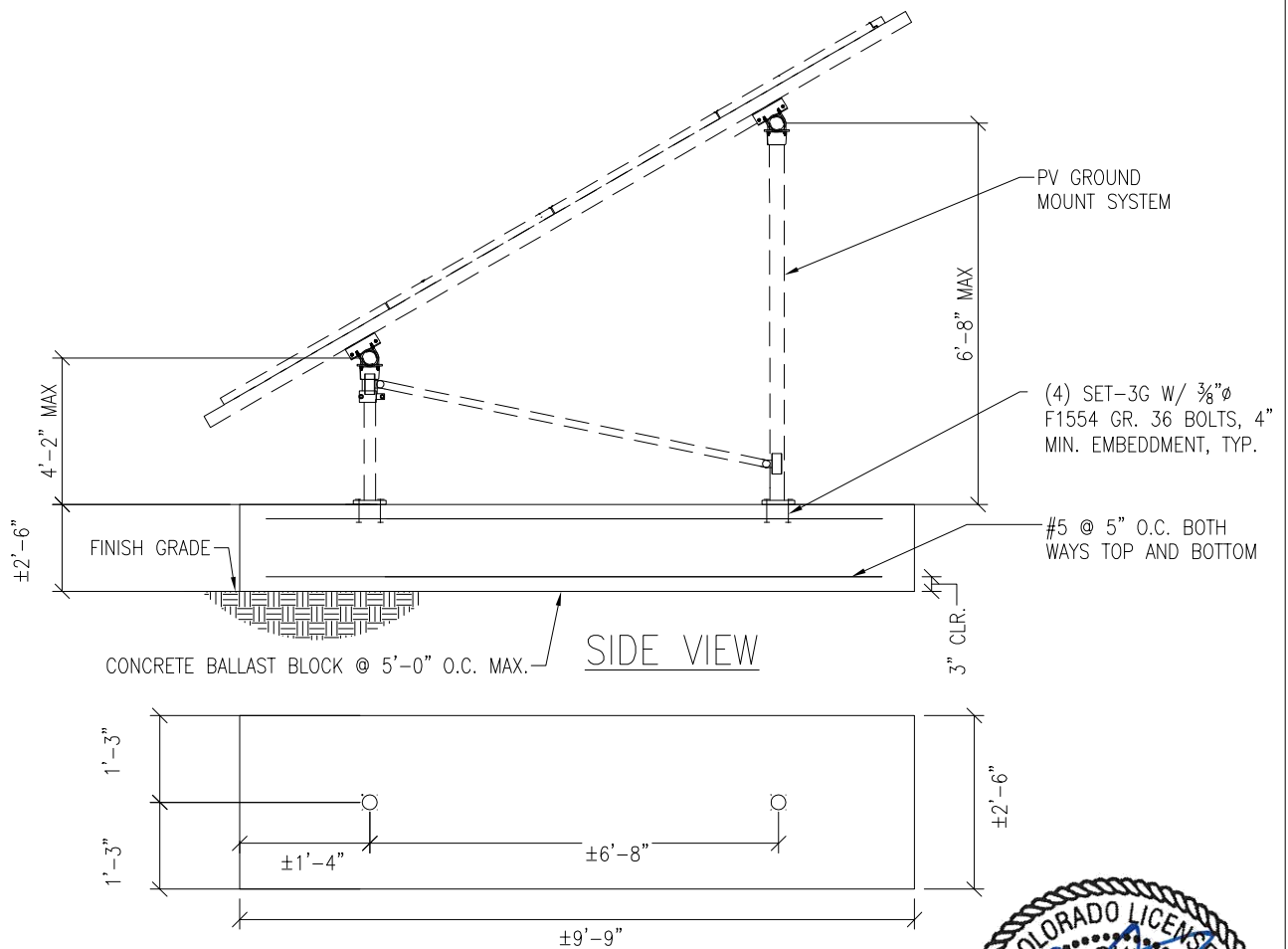

Vector Structural Engineering requires that we review each site-specific install, and we are not liable for installs at site-specific locations we have not reviewed. This document does not address site-specific installations.

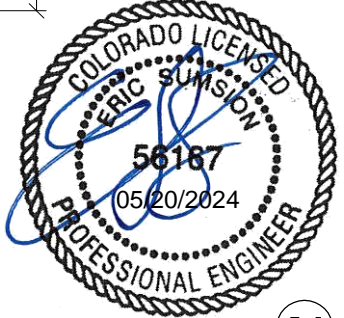

PV ARRAY SECTION

N.T.S.

S4

651 W GALENA PARK BLVD. #101
 DRAPER, UTAH 84020

(801) 990-1775
 (801) 990-1776 FAX

WWW.VECTORSE.COM



PROJECT: Sunturf Package D3 Ground Mount

WIND PRESSURES

Calculations per:	ASCE 7-16	
Design Wind Speed, V [mph]:	170	
Risk Category:	I	(Table 1.5-1)
Exposure Category:	C	(Section 26.7)
Elevation [ft]:	7.9	
Ground Elevation Factor, K_e :	1.00	(Table 26.9-1)
α :	9.5	(Table 26.11-1)
z_g [ft]:	900	(Table 26.11-1)
Velocity Pressure Exposure Coefficient, K_h :	0.85	(Table 26.10-1)
Topographic Factor, K_{ht} :	1.0	(Section 26.8)
Wind Directionality Factor, K_d :	0.85	(Table 26.6-1)
Internal Pressure Coefficient, GC_{pi} :	0.00	(Figure 26.13-1)
Velocity Pressure, q_h [psf]:	53.37	(Equation 26.10-1)
Gust Effect Factor, G:	0.85	(Section 26.11.4)
Panel Slope [degrees]:	20.0	
Wind Flow:	Clear	
Roof Configuration:	Monoslope	

Wind Pressures in Transverse (N-S) Direction

Net Pressure Coefficients per Figure 27.3-4

Clear Wind Flow	C_{NW}	C_{NL}
Case 1 ($\gamma = 0^\circ$, Load Case A)	-1.3	-1.5
Case 2 ($\gamma = 0^\circ$, Load Case B)	-2.2	-0.2
Case 3 ($\gamma = 180^\circ$, Load Case A)	1.6	1.7
Case 4 ($\gamma = 180^\circ$, Load Case B)	2.1	0.7

Design Wind Pressures per Equation 27.3-2 [psf]

Clear Wind Flow	$q_h GC_{NW}$	$q_h GC_{NL}$
Case 1 ($\gamma = 0^\circ$, Load Case A)	-59.0	-68.0
Case 2 ($\gamma = 0^\circ$, Load Case B)	-99.8	-9.1
Case 3 ($\gamma = 180^\circ$, Load Case A)	72.6	77.1
Case 4 ($\gamma = 180^\circ$, Load Case B)	95.3	31.8
Case 5 ($\gamma = 0^\circ$, 16 psf Min. Horiz.)	-16.0	-16.0
Case 6 ($\gamma = 180^\circ$, 16 psf Min. Horiz.)	16.0	16.0



JOB NO.: U2716-0277-211

DESIGNED: STB

Foundation Option 1: Drilled Concrete Pier



PROJECT: Sunturf Package D3 Ground Mount

DRILLED CONCRETE PIER DESIGN

Column Reactions:

Max. Shear, V [k]:	1.2	Max. Down, P _d [k]:	2.6
Max. Moment, M [k-ft]:	0.0	Max. Uplift, P _u [k]:	2.5

Pier Properties:

Pier Shape:	Round	Volume of Concrete [ft ³]:	8
Pier Diameter, b [ft]:	1.5	Volume of Concrete [yd ³]:	0.3
Top of Pier Elevation [ft]:	0.00	Weight of Concrete [k]:	1.2
Pier Depth, d [ft]:	4.5		

Soil Properties:

Allow. Bearing Pressure [psf]:	1,500	<u>Optional Parameters for Uplift:</u>	
1/3 increase for short term loads?	No		
Lateral Bearing, S [pcf]:	150	Skin Friction* [psf]:	250
Max. Lateral Bearing (opt'l) [psf]:		Top Length to Ignore [ft]:	0
Top Depth to Ignore [ft]:	0	1/3 increase for short term loads?	No
1/3 increase for short term loads?	No	Combine w/ Bearing:	No
1/2" deflection at t/o pier allowed:	Yes		

*per IBC Section 1810.3.3.1.4

Check Bearing:

Bearing Capacity [k]:	5.3
-----------------------	-----

Bearing capacity OK.

Check Uplift:

Uplift Capacity [k]:	6.4
----------------------	-----

Uplift capacity OK.

Check Lateral Bearing:

Top of Pier Constrained?:	No
Applied Lateral Force, P [lb]:	1,216
Point of Application, h [ft]:	0.0
S _{max} [psf]:	
S [psf]:	450
A = 2.34*P/(S _b):	4.22
Required Pier Depth, d _{reqd} [ft]:	4.20

IBC Section 1807.3.2.1

IBC Eq. 18-1

Result: **Lateral bearing capacity OK.**

Foundation Option 2: Helical Pier

The ground screws and helical piers must be tested to 1.5 times uplift and 2.0 times lateral reactions found in the table below.

Load (ASD)	Value (lbs)	Factor of Safety	Test Value (lbs)
UPLIFT	2461	1.5	3692
LATERAL	1217	2	2434

Foundation Option 3: Ground Screw

The ground screws and helical piers must be tested to 1.5 times uplift and 2.0 times lateral reactions found in the table below.

Load (ASD)	Value (lbs)	Factor of Safety	Test Value (lbs)
UPLIFT	2461	1.5	3692
LATERAL	1217	2	2434



JOB NO.: U2716-0277-211

DESIGNED: STB

Foundation Option 4: Ballasted Block

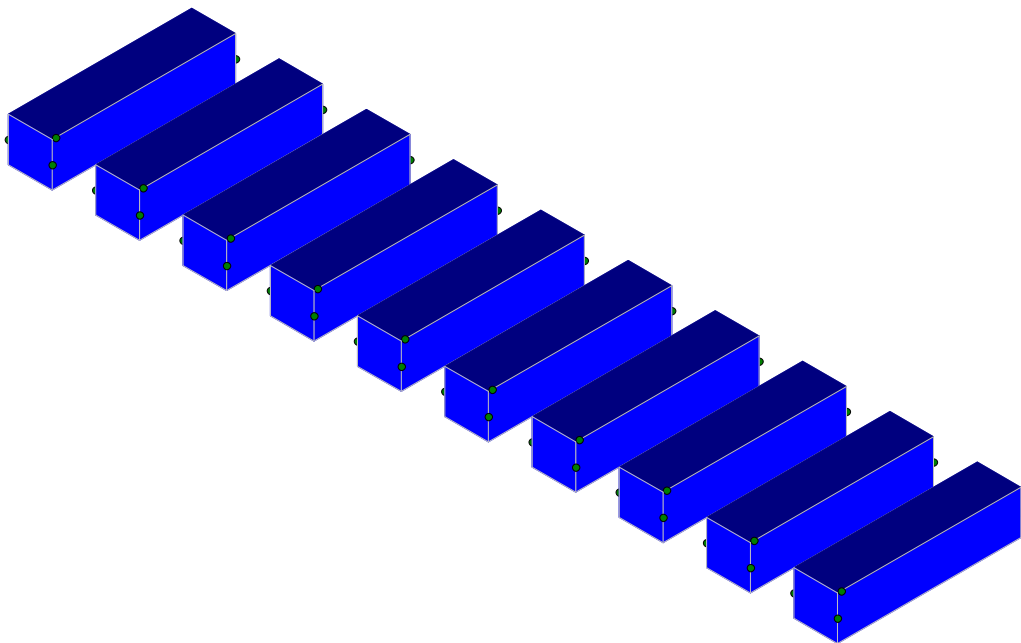
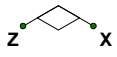

Results for LC 1, 1.0 D

Vector Structural Engineeri...	Ground Mount	SK - 1
STB		Sept 13, 2023 at 4:04 PM
U2716.0277.211		Sunmodo Sunturf D3 GM v2 85x45...

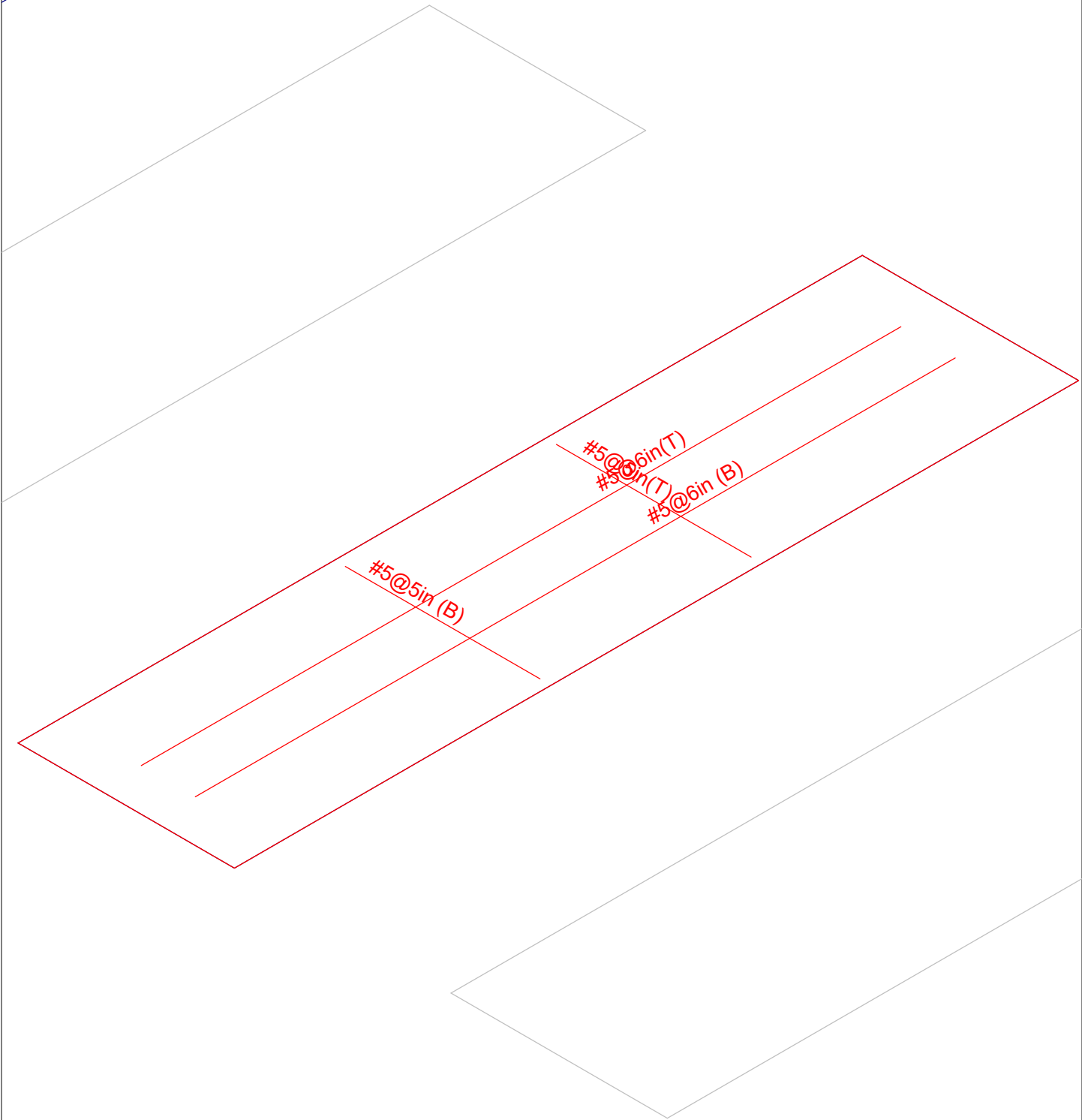

Results for LC 1, 1.0 D

Vector Structural Engineeri..	Ground Mount	SK - 1
STB		Mar 30, 2021 at 5:07 PM
U2716.0277.211		Sunmodo Sunturf D3 GM v2 85x45...



(Global) Model Settings

Display Sections for Member Calcs	5
Max Internal Sections for Member Calcs	100
Mesh Size (in)	12
Max Iterations	10
Merge Tolerance (in)	0.12
Solver	Sparse Accelerated
Coefficient of Friction	0.3
No. of Shear Regions	4
Shear Region Spacing Increment (in)	4
Min 1 Bar Dia Spacing for Beams?	No
Optimize footings for OTM / Sliding?	Yes
Parame Beta Factor	0.65
Pile Safety Factor	3
Min % Steel for Pedestal	Auto
Concrete Stress Block	Rectangular
Concrete Rebar Set	ASTM A615
Include WWR	No
Concrete Code	ACI 318-14
HR Steel Pile Code	AISC 14th (360-10): ASD
Wood Pile Code	AWC NDS-15 / SDPWS-15 ASD

Concrete Properties

	Label	E [ksi]	G [ksi]	Nu	Therm (/1E...	Density[lb/f...	f'c[psi]	Lambda	Flex Steel[...	Shear Stee...
1	Conc3000NW	3156	1372	0.15	0.6	145	3000	1	60000	60000
2	Conc3500NW	3409	1482	0.15	0.6	145	3500	1	60000	60000
3	Conc4000NW	3644	1584	0.15	0.6	145	4000	1	60000	60000
4	Conc3000LW	2085	907	0.15	0.6	109.999	3000	0.75	60000	60000
5	Conc3500LW	2252	979	0.15	0.6	109.999	3500	0.75	60000	60000
6	Conc4000LW	2408	1047	0.15	0.6	109.999	4000	0.75	60000	60000
7	Conc2500NW	3156	1372	0.15	0.6	145	2500	1	60000	60000

General Design Parameters

	Label	Max Bending Chk	Max Shear Chk	Top Cover[in]	Bottom Cover[in]
1	Typical	1	1	3	3

Slab Rebar Parameters

	Label	Top BarBottom ...	Max Top Bar...	Min Top Bar ...	Max Bot Bar ...	Min Bot Bar ...	Spacing I...	Side Cove...	Rebar Options	
1	Typical	#5	#5	8	3	8	3	1	0	Optimize

Soil Definitions

	Label	Subgrade Modulus[lb/ft^3]	Allowable Bearing[psf]	Depth Properties	Default?
1	Default	1e+5	1500	None	Yes

Point Loads and Moments (Cat 1 : DL)

	Label	Direction	Magnitude[lb.ft]
1	R3D_N1_1	X	-5.23
2	R3D_N1_1	Y	171.588
3	R3D_N2_1	X	3.968
4	R3D_N2_1	Y	141.652
5	R3D_N132_1	Y	162.039
6	R3D_N133_1	X	1.326
7	R3D_N133_1	Y	149.746



Company : Vector Structural Engineering
 Designer : STB
 Job Number : U2716.0277.211
 Model Name : Ground Mount

Sept 13, 2023
 4:04 PM
 Checked By: JSP

Point Loads and Moments (Cat 1 : DL) (Continued)

	Label	Direction	Magnitude[lb,lb-ft]
8	R3D_N109_1	Y	149.019
9	R3D_N109_1	Z	1.078
10	R3D_N110A_1	Y	148.999
11	R3D_N121_1	Y	162.16
12	R3D_N122_1	X	-2.471
13	R3D_N122_1	Y	147.392
14	R3D_N133B_1	Y	154.221
15	R3D_N134B_1	Y	141.311
16	R3D_N151_1	Y	162.073
17	R3D_N152_1	X	-1.287
18	R3D_N152_1	Y	149.917
19	R3D_N157A	Y	154.487
20	R3D_N158A	X	-1.03
21	R3D_N158A	Y	141.521
22	R3D_N155B	Y	161.533
23	R3D_N156B	X	2.443
24	R3D_N156B	Y	146.893
25	R3D_N167_1	Y	150.779
26	R3D_N168_1	Y	149.982
27	R3D_N179_1	X	5.171
28	R3D_N179_1	Y	168.234
29	R3D_N180_1	X	-3.592
30	R3D_N180_1	Y	138.974

Point Loads and Moments (Cat 67 : OL1)

	Label	Direction	Magnitude[lb,lb-ft]
1	R3D_N1_1	X	94.359
2	R3D_N1_1	Y	-3125.903
3	R3D_N1_1	Z	1585.095
4	R3D_N2_1	X	-62.898
5	R3D_N2_1	Y	-1093.15
6	R3D_N2_1	Z	-86.714
7	R3D_N132_1	X	-10.305
8	R3D_N132_1	Y	-3175.542
9	R3D_N132_1	Z	1704.141
10	R3D_N133_1	X	-24.139
11	R3D_N133_1	Y	-1161.881
12	R3D_N133_1	Z	-92.067
13	R3D_N109_1	X	3.144
14	R3D_N109_1	Y	-2901.96
15	R3D_N109_1	Z	1606.494
16	R3D_N110A_1	Y	-1229.886
17	R3D_N110A_1	Z	-89.67
18	R3D_N121_1	X	18.582
19	R3D_N121_1	Y	-3179.352
20	R3D_N121_1	Z	1714.618
21	R3D_N122_1	X	42.299
22	R3D_N122_1	Y	-1112.617
23	R3D_N122_1	Z	-91.467
24	R3D_N133B_1	X	-6.797
25	R3D_N133B_1	Y	-2871.752
26	R3D_N133B_1	Z	1490.976
27	R3D_N134B_1	X	-13.849
28	R3D_N134B_1	Y	-1176.034
29	R3D_N134B_1	Z	-85.37
30	R3D_N151_1	X	9.317



Point Loads and Moments (Cat 67 : OL1) (Continued)

	Label	Direction	Magnitude[lb.-ft]
31	R3D_N151_1	Y	-3170.39
32	R3D_N151_1	Z	1696.464
33	R3D_N152_1	X	23.466
34	R3D_N152_1	Y	-1170.443
35	R3D_N152_1	Z	-91.834
36	R3D_N157A	X	7.827
37	R3D_N157A	Y	-2883.508
38	R3D_N157A	Z	1500.516
39	R3D_N158A	X	17.525
40	R3D_N158A	Y	-1172.721
41	R3D_N158A	Z	-85.609
42	R3D_N155B	X	-19.112
43	R3D_N155B	Y	-3163.202
44	R3D_N155B	Z	1705.931
45	R3D_N156B	X	-41.727
46	R3D_N156B	Y	-1109.771
47	R3D_N156B	Z	-91.144
48	R3D_N167_1	X	-3.061
49	R3D_N167_1	Y	-2935.951
50	R3D_N167_1	Z	1620.084
51	R3D_N168_1	Y	-1240.007
52	R3D_N168_1	Z	-89.459
53	R3D_N179_1	X	-93.512
54	R3D_N179_1	Y	-3054.343
55	R3D_N179_1	Z	1550.181
56	R3D_N180_1	X	57.25
57	R3D_N180_1	Y	-1067.856
58	R3D_N180_1	Z	-85.741

Point Loads and Moments (Cat 68 : OL2)

	Label	Direction	Magnitude[lb.-ft]
1	R3D_N1_1	X	145.524
2	R3D_N1_1	Y	-4176.451
3	R3D_N1_1	Z	1308.698
4	R3D_N2_1	X	-4.877
5	R3D_N2_1	Y	542.015
6	R3D_N2_1	Z	-72.107
7	R3D_N132_1	X	-15.03
8	R3D_N132_1	Y	-4260.883
9	R3D_N132_1	Z	1459.482
10	R3D_N133_1	X	-3.324
11	R3D_N133_1	Y	633.954
12	R3D_N133_1	Z	-77.798
13	R3D_N109_1	X	4.366
14	R3D_N109_1	Y	-3892.332
15	R3D_N109_1	Z	1356.077
16	R3D_N110A_1	X	1.076
17	R3D_N110A_1	Y	548.711
18	R3D_N110A_1	Z	-75.421
19	R3D_N121_1	X	26.96
20	R3D_N121_1	Y	-4264.232
21	R3D_N121_1	Z	1477.825
22	R3D_N122_1	X	1.467
23	R3D_N122_1	Y	652.525
24	R3D_N122_1	Z	-77.478
25	R3D_N133B_1	X	-9.946



Point Loads and Moments (Cat 68 : OL2) (Continued)

	Label	Direction	Magnitude[lb.lb-ft]
26	R3D_N133B_1	Y	-3830.594
27	R3D_N133B_1	Z	1187.243
28	R3D_N134B_1	Y	427.619
29	R3D_N134B_1	Z	-70.33
30	R3D_N151_1	X	13.526
31	R3D_N151_1	Y	-4253.675
32	R3D_N151_1	Z	1448.379
33	R3D_N152_1	X	3.265
34	R3D_N152_1	Y	624.828
35	R3D_N152_1	Z	-77.524
36	R3D_N157A	X	11.377
37	R3D_N157A	Y	-3847.135
38	R3D_N157A	Z	1199.719
39	R3D_N158A	Y	437.173
40	R3D_N158A	Z	-70.611
41	R3D_N155B	X	-27.806
42	R3D_N155B	Y	-4242.015
43	R3D_N155B	Z	1468.509
44	R3D_N156B	X	-1.34
45	R3D_N156B	Y	646.336
46	R3D_N156B	Z	-77.15
47	R3D_N167_1	X	-4.325
48	R3D_N167_1	Y	-3937.065
49	R3D_N167_1	Z	1366.05
50	R3D_N168_1	Y	551.544
51	R3D_N168_1	Z	-75.203
52	R3D_N179_1	X	-144.548
53	R3D_N179_1	Y	-4081.627
54	R3D_N179_1	Z	1280.828
55	R3D_N180_1	X	4.148
56	R3D_N180_1	Y	531.995
57	R3D_N180_1	Z	-71.344

Point Loads and Moments (Cat 69 : OL3)

	Label	Direction	Magnitude[lb.lb-ft]
1	R3D_N1_1	X	-121.144
2	R3D_N1_1	Y	3914.295
3	R3D_N1_1	Z	-1860.665
4	R3D_N2_1	X	66.609
5	R3D_N2_1	Y	1061.433
6	R3D_N2_1	Z	101.868
7	R3D_N132_1	X	13.098
8	R3D_N132_1	Y	3979.234
9	R3D_N132_1	Z	-2008.465
10	R3D_N133_1	X	25.786
11	R3D_N133_1	Y	1119.287
12	R3D_N133_1	Z	108.347
13	R3D_N109_1	X	-3.962
14	R3D_N109_1	Y	3636.187
15	R3D_N109_1	Z	-1890.345
16	R3D_N110A_1	Y	1203.581
17	R3D_N110A_1	Z	105.472
18	R3D_N121_1	X	-23.596
19	R3D_N121_1	Y	3983.738
20	R3D_N121_1	Z	-2022.251
21	R3D_N122_1	X	-44.516



Point Loads and Moments (Cat 69 : OL3) (Continued)

	Label	Direction	Magnitude[lb.lb-ft]
22	R3D N122 1	Y	1064.851
23	R3D N122 1	Z	107.67
24	R3D N133B 1	X	8.644
25	R3D N133B 1	Y	3595.079
26	R3D N133B 1	Z	-1743.466
27	R3D N134B 1	X	14.561
28	R3D N134B 1	Y	1165.783
29	R3D N134B 1	Z	100.188
30	R3D N151 1	X	-11.833
31	R3D N151 1	Y	3972.733
32	R3D N151 1	Z	-1998.722
33	R3D N152 1	X	-25.073
34	R3D N152 1	Y	1129.653
35	R3D N152 1	Z	108.06
36	R3D N157A	X	-9.942
37	R3D N157A	Y	3609.928
38	R3D N157A	Z	-1755.371
39	R3D N158A	X	-18.433
40	R3D N158A	Y	1160.846
41	R3D N158A	Z	100.481
42	R3D N155B	X	24.281
43	R3D N155B	Y	3963.416
44	R3D N155B	Z	-2011.726
45	R3D N156B	X	43.898
46	R3D N156B	Y	1062.822
47	R3D N156B	Z	107.281
48	R3D N167 1	X	3.87
49	R3D N167 1	Y	3678.647
50	R3D N167 1	Z	-1906.105
51	R3D N168 1	Y	1213.744
52	R3D N168 1	Z	105.217
53	R3D N179 1	X	120.107
54	R3D N179 1	Y	3824.807
55	R3D N179 1	Z	-1819.827
56	R3D N180 1	X	-60.584
57	R3D N180 1	Y	1036.486
58	R3D N180 1	Z	100.732

Point Loads and Moments (Cat 70 : OL4)

	Label	Direction	Magnitude[lb.lb-ft]
1	R3D N1 1	X	-58.658
2	R3D N1 1	Y	2300.013
3	R3D N1 1	Z	-1614.3
4	R3D N2 1	X	90.11
5	R3D N2 1	Y	1913.127
6	R3D N2 1	Z	88.027
7	R3D N132 1	X	6.883
8	R3D N132 1	Y	2326.508
9	R3D N132 1	Z	-1706.471
10	R3D N133 1	X	33.779
11	R3D N133 1	Y	2065.45
12	R3D N133 1	Z	92.775
13	R3D N109 1	X	-2.222
14	R3D N109 1	Y	2126.884
15	R3D N109 1	Z	-1619.641
16	R3D N110A 1	Y	2118.597



Point Loads and Moments (Cat 70 : OL4) (Continued)

	Label	Direction	Magnitude[lb.-ft]
17	R3D N110A 1	Z	90.555
18	R3D N121 1	X	-12.491
19	R3D N121 1	Y	2330.277
20	R3D N121 1	Z	-1711.774
21	R3D N122 1	X	-61.602
22	R3D N122 1	Y	2003.04
23	R3D N122 1	Z	92.067
24	R3D N133B 1	X	4.523
25	R3D N133B 1	Y	2116.494
26	R3D N133B 1	Z	-1542.668
27	R3D N134B 1	X	20.218
28	R3D N134B 1	Y	1972.088
29	R3D N134B 1	Z	87.028
30	R3D N151 1	X	-6.259
31	R3D N151 1	Y	2322.897
32	R3D N151 1	Z	-1701.291
33	R3D N152 1	X	-32.818
34	R3D N152 1	Y	2073.03
35	R3D N152 1	Z	92.582
36	R3D N157A	X	-5.25
37	R3D N157A	Y	2124.683
38	R3D N157A	Z	-1549.837
39	R3D N158A	X	-25.564
40	R3D N158A	Y	1972.489
41	R3D N158A	Z	87.225
42	R3D N155B	X	12.805
43	R3D N155B	Y	2318.747
44	R3D N155B	Z	-1704.115
45	R3D N156B	X	60.828
46	R3D N156B	Y	1995.414
47	R3D N156B	Z	91.771
48	R3D N167 1	X	2.123
49	R3D N167 1	Y	2152.272
50	R3D N167 1	Z	-1634.172
51	R3D N168 1	X	-1.656
52	R3D N168 1	Y	2135.1
53	R3D N168 1	Z	90.363
54	R3D N179 1	X	57.948
55	R3D N179 1	Y	2246.924
56	R3D N179 1	Z	-1578.212
57	R3D N180 1	X	-82.18
58	R3D N180 1	Y	1870.256
59	R3D N180 1	Z	87.013

Slabs

	Label	Thickness [in]	Material	Local Axis Angle...	Analysis Offset [in]	Passive Pressur...	Soil Overburden ...	lcr Factor
1	S1	30	Conc2500NW	0	0	0	0	1
2	S2	30	Conc2500NW	0	0	0	0	1
3	S3	30	Conc2500NW	0	0	0	0	1
4	S4	30	Conc2500NW	0	0	0	0	1
5	S5	30	Conc2500NW	0	0	0	0	1
6	S6	30	Conc2500NW	0	0	0	0	1
7	S7	30	Conc2500NW	0	0	0	0	1
8	S8	30	Conc2500NW	0	0	0	0	1
9	S9	30	Conc2500NW	0	0	0	0	1
10	S10	30	Conc2500NW	0	0	0	0	1



Load Combinations

Label	So	Se	A	SF	Cat	Fac	Cat	Fac	Cat	Fac	Cat	Fac	Cat	Fac	Cat	Fac	Cat	Fac	Cat	Fac
1	1.0 D	Yes	Yes	1.5	DL	1														
2	1.0 D + 1.0 D	Yes	Yes	1.5	DL	1	RLL	1												
3	1.0 D + 0.6 D	Yes	Yes	1.5	DL	1	RLL		OL1	0.6										
4	1.0 D + 0.6 D	Yes	Yes	1.5	DL	1	RLL		OL2	0.6										
5	1.0 D + 0.6 D	Yes	Yes	1.5	DL	1	RLL		OL3	0.6										
6	1.0 D + 0.6 D	Yes	Yes	1.5	DL	1	RLL		OL4	0.6										
7	1.0 D + 0.6 D	Yes	Yes	1.5	DL	1	RLL		OL5	0.6										
8	1.0 D + 0.6 D	Yes	Yes	1.5	DL	1	RLL		OL6	0.6										
9	1.0 D + 0.6 D	Yes	Yes	1.5	DL	1	RLL	0.75	OL1	0.45										
10	1.0 D + 0.6 D	Yes	Yes	1.5	DL	1	RLL	0.75	OL2	0.45										
11	1.0 D + 0.6 D	Yes	Yes	1.5	DL	1	RLL	0.75	OL3	0.45										
12	1.0 D + 0.6 D	Yes	Yes	1.5	DL	1	RLL	0.75	OL4	0.45										
13	1.0 D + 0.6 D	Yes	Yes	1.5	DL	1	RLL	0.75	OL5	0.45										
14	1.0 D + 0.6 D	Yes	Yes	1.5	DL	1	RLL	0.75	OL6	0.45										
15	0.6 D + 0.6 D	Yes	Yes		DL	0.6	RLL		OL1	0.6										
16	0.6 D + 0.6 D	Yes	Yes		DL	0.6	RLL		OL2	0.6										
17	0.6 D + 0.6 D	Yes	Yes		DL	0.6	RLL		OL3	0.6										
18	0.6 D + 0.6 D	Yes	Yes		DL	0.6	RLL		OL4	0.6										
19	0.6 D + 0.6 D	Yes	Yes		DL	0.6	RLL		OL5	0.6										
20	0.6 D + 0.6 D	Yes	Yes		DL	0.6	RLL		OL6	0.6										
21																				
22	1.4D	Yes			DL	1.4														
23	1.2D+1.6D	Yes			DL	1.2	RLL	1.6												
24	1.2D+1.6D	Yes			DL	1.2	RLL	1.6	OL1	0.5										
25	1.2D+1.6D	Yes			DL	1.2	RLL	1.6	OL2	0.5										
26	1.2D+1.6D	Yes			DL	1.2	RLL	1.6	OL3	0.5										
27	1.2D+1.6D	Yes			DL	1.2	RLL	1.6	OL4	0.5										
28	1.2D+1.6D	Yes			DL	1.2	RLL	1.6	OL5	0.5										
29	1.2D+1.6D	Yes			DL	1.2	RLL	1.6	OL6	0.5										
30	1.2D+1.0D	Yes			DL	1.2			OL1	1										
31	1.2D-1.0D	Yes			DL	1.2			OL2	1										
32	1.2D+1.0D	Yes			DL	1.2			OL3	1										
33	1.2D-1.0D	Yes			DL	1.2			OL4	1										
34	1.2D+1.0D	Yes			DL	1.2			OL5	1										
35	1.2D-1.0D	Yes			DL	1.2			OL6	1										
36	.9D+1.0D	Yes			DL	0.9			OL1	1										
37	.9D-1.0Wx	Yes			DL	0.9			OL2	1										
38	.9D+1.0D	Yes			DL	0.9			OL3	1										
39	.9D-1.0Wz	Yes			DL	0.9			OL4	1										
40	.9D+1.0D	Yes			DL	0.9			OL5	1										
41	.9D-1.0D	Yes			DL	0.9			OL6	1										

Design Strips

Label	Rebar Angle from Pl...	No. of Design Cuts	Design Rule
1 DS1	0	50	Typical
2 DS2	90	50	Typical

Load Categories

Category	Point Loads	Line Loads	Area Loads
1 DL	30		
2 OL1	58		
3 OL2	57		
4 OL3	58		
5 OL4	59		



Company : Vector Structural Engineering
 Designer : STB
 Job Number : U2716.0277.211
 Model Name : Ground Mount

Sept 13, 2023
 4:04 PM
 Checked By: JSP

Strip Reinforcing

	Label	UC Top	LC	Top Bars	Governin...	UC Bot	LC	Bot Bars/...	Governin...	UC Shear	LC	Governin...
1	DS1	0.017	32	#5@5in	DS1-X21	0.024	37	#5@5in	DS1-X25	0.047	37	DS1-X9
2	DS2	0.001	36	#5@5in	DS2-X26	0.002	32	#5@5in	DS2-X25	0.005	32	DS2-X25

Slab Overturning Safety Factors (By Combination)

	LC	Slab	Angle[deg]	Mo-xx[lb-ft]	Ms-xx[lb-ft]	Mo-zz[lb-ft]	Ms-zz[lb-ft]	Ms-xx/Mo-xx	Ms-zz/Mo-zz
1	1	S1	0	0	51416.53	0	12289.235	9.99+	9.99+
2	1	S2	0	0	51462.152	0	12267.055	9.99+	9.99+
3	1	S3	0	0	51458.607	0	12287.648	9.99+	9.99+
4	1	S4	0	0	51395.36	0	12263.946	9.99+	9.99+
5	1	S5	0	0	51479.772	0	12280.949	9.99+	9.99+
6	1	S6	0	0	51481.352	0	12287.736	9.99+	9.99+
7	1	S7	0	0	51397.537	0	12267.116	9.99+	9.99+
8	1	S8	0	0	51453.449	0	12273.956	9.99+	9.99+
9	1	S9	0	0	51470.174	0	12270.482	9.99+	9.99+
10	1	S10	0	0	51388.828	0	12274.593	9.99+	9.99+
11	2	S1	0	0	51416.53	0	12289.235	9.99+	9.99+
12	2	S2	0	0	51462.152	0	12267.055	9.99+	9.99+
13	2	S3	0	0	51458.607	0	12287.648	9.99+	9.99+
14	2	S4	0	0	51395.36	0	12263.946	9.99+	9.99+
15	2	S5	0	0	51479.772	0	12280.949	9.99+	9.99+
16	2	S6	0	0	51481.352	0	12287.736	9.99+	9.99+
17	2	S7	0	0	51397.537	0	12267.116	9.99+	9.99+
18	2	S8	0	0	51453.449	0	12273.956	9.99+	9.99+
19	2	S9	0	0	51470.174	0	12270.482	9.99+	9.99+
20	2	S10	0	0	51388.828	0	12274.593	9.99+	9.99+
21	3	S1	0	20943.631	51786.552	3211.482	12289.235	2.473	3.827
22	3	S2	0	19820.06	51581.107	3103.6	12267.055	2.602	3.953
23	3	S3	0	21451.143	51705.751	3310.298	12287.648	2.41	3.712
24	3	S4	0	19434.684	51621.788	3066.81	12263.946	2.656	3.999
25	3	S5	0	21456.01	51708.039	3304.733	12287.578	2.41	3.718
26	3	S6	0	21423.099	51708.61	3304.8	12287.736	2.414	3.718
27	3	S7	0	19512.451	51624.616	3080.2	12267.116	2.646	3.983
28	3	S8	0	21344.455	51699.093	3295.988	12286.173	2.422	3.728
29	3	S9	0	20042.519	51601.875	3136.561	12270.482	2.575	3.912
30	3	S10	0	20464.48	51750.92	3146.042	12282.49	2.529	3.904
31	4	S1	0	25082.028	51786.552	2936.798	12289.235	2.065	4.185
32	4	S2	0	23529.887	51581.107	2515.879	12267.055	2.192	4.876
33	4	S3	0	25729.122	51705.751	2751.421	12287.648	2.01	4.466
34	4	S4	0	23039.867	51621.788	2567.149	12263.946	2.241	4.777
35	4	S5	0	25698.373	51708.039	2747.728	12287.578	2.012	4.472
36	4	S6	0	25649.21	51708.61	2746.822	12287.736	2.016	4.473
37	4	S7	0	23143.668	51624.616	2574.537	12267.116	2.231	4.765
38	4	S8	0	25594.976	51699.093	2740.479	12286.173	2.02	4.483
39	4	S9	0	23796.554	51601.875	2545.628	12270.482	2.168	4.82
40	4	S10	0	24512.008	51750.92	2872.824	12282.49	2.111	4.275
41	5	S1	0	0	56982.981	0	16102.834	9.99+	9.99+
42	5	S2	0	0	57586.827	0	15902.824	9.99+	9.99+
43	5	S3	0	0	56853.327	0	16176.258	9.99+	9.99+
44	5	S4	0	0	57501.679	0	15799.784	9.99+	9.99+
45	5	S5	0	0	57188.683	0	16046.513	9.99+	9.99+
46	5	S6	0	0	57256.623	0	16169.884	9.99+	9.99+
47	5	S7	0	0	57468.939	0	15887.76	9.99+	9.99+
48	5	S8	0	0	56839.661	0	15941.366	9.99+	9.99+
49	5	S9	0	0	57652.498	0	15933.971	9.99+	9.99+
50	5	S10	0	0	56823.563	0	15831.277	9.99+	9.99+
51	6	S1	0	0	60943.288	0	15401.913	9.99+	9.99+



Company : Vector Structural Engineering
 Designer : STB
 Job Number : U2716.0277.211
 Model Name : Ground Mount

Sept 13, 2023
 4:04 PM
 Checked By: JSP

Slab Overturning Safety Factors (By Combination) (Continued)

	LC	Slab	Angle[deg]	Mo-xx[lb-ft]	Ms-xx[lb-ft]	Mo-zz[lb-ft]	Ms-zz[lb-ft]	Ms-xx/Mo-xx	Ms-zz/Mo-zz
52	6	S2	0	0	61991.159	0	15454.498	9.99+	9.99+
53	6	S3	0	0	61351.906	0	15648.775	9.99+	9.99+
54	6	S4	0	0	61233.235	0	15293.272	9.99+	9.99+
55	6	S5	0	0	61718.305	0	15513.925	9.99+	9.99+
56	6	S6	0	0	61766.234	0	15643.298	9.99+	9.99+
57	6	S7	0	0	61232.245	0	15386.216	9.99+	9.99+
58	6	S8	0	0	61309.217	0	15399.127	9.99+	9.99+
59	6	S9	0	0	62082.496	0	15485.311	9.99+	9.99+
60	6	S10	0	0	60702.443	0	15398.824	9.99+	9.99+
61	7	S1	0	0	51416.53	0	12289.235	9.99+	9.99+
62	7	S2	0	0	51462.152	0	12267.055	9.99+	9.99+
63	7	S3	0	0	51458.607	0	12287.648	9.99+	9.99+
64	7	S4	0	0	51395.36	0	12263.946	9.99+	9.99+
65	7	S5	0	0	51479.772	0	12280.949	9.99+	9.99+
66	7	S6	0	0	51481.352	0	12287.736	9.99+	9.99+
67	7	S7	0	0	51397.537	0	12267.116	9.99+	9.99+
68	7	S8	0	0	51453.449	0	12273.956	9.99+	9.99+
69	7	S9	0	0	51470.174	0	12270.482	9.99+	9.99+
70	7	S10	0	0	51388.828	0	12274.593	9.99+	9.99+
71	8	S1	0	0	51416.53	0	12289.235	9.99+	9.99+
72	8	S2	0	0	51462.152	0	12267.055	9.99+	9.99+
73	8	S3	0	0	51458.607	0	12287.648	9.99+	9.99+
74	8	S4	0	0	51395.36	0	12263.946	9.99+	9.99+
75	8	S5	0	0	51479.772	0	12280.949	9.99+	9.99+
76	8	S6	0	0	51481.352	0	12287.736	9.99+	9.99+
77	8	S7	0	0	51397.537	0	12267.116	9.99+	9.99+
78	8	S8	0	0	51453.449	0	12273.956	9.99+	9.99+
79	8	S9	0	0	51470.174	0	12270.482	9.99+	9.99+
80	8	S10	0	0	51388.828	0	12274.593	9.99+	9.99+
81	9	S1	0	15707.724	51786.552	2408.612	12289.235	3.297	5.102
82	9	S2	0	14865.045	51581.107	2327.7	12267.055	3.47	5.27
83	9	S3	0	16088.357	51705.751	2482.723	12287.648	3.214	4.949
84	9	S4	0	14576.013	51621.788	2300.107	12263.946	3.542	5.332
85	9	S5	0	16092.007	51708.039	2478.55	12287.578	3.213	4.958
86	9	S6	0	16067.324	51708.61	2478.6	12287.736	3.218	4.958
87	9	S7	0	14634.339	51624.616	2310.15	12267.116	3.528	5.31
88	9	S8	0	16008.341	51699.093	2471.991	12286.173	3.23	4.97
89	9	S9	0	15031.889	51601.875	2352.421	12270.482	3.433	5.216
90	9	S10	0	15348.36	51750.92	2359.532	12282.49	3.372	5.205
91	10	S1	0	18811.521	51786.552	2202.598	12289.235	2.753	5.579
92	10	S2	0	17647.415	51581.107	1886.909	12267.055	2.923	6.501
93	10	S3	0	19296.841	51705.751	2063.566	12287.648	2.679	5.955
94	10	S4	0	17279.9	51621.788	1925.362	12263.946	2.987	6.37
95	10	S5	0	19273.779	51708.039	2060.796	12287.578	2.683	5.963
96	10	S6	0	19236.908	51708.61	2060.117	12287.736	2.688	5.965
97	10	S7	0	17357.751	51624.616	1930.903	12267.116	2.974	6.353
98	10	S8	0	19196.232	51699.093	2055.359	12286.173	2.693	5.978
99	10	S9	0	17847.416	51601.875	1909.221	12270.482	2.891	6.427
100	10	S10	0	18384.006	51750.92	2154.618	12282.49	2.815	5.701
101	11	S1	0	0	55591.368	0	15149.434	9.99+	9.99+
102	11	S2	0	0	56055.658	0	14993.882	9.99+	9.99+
103	11	S3	0	0	55504.647	0	15204.105	9.99+	9.99+
104	11	S4	0	0	55975.099	0	14915.824	9.99+	9.99+
105	11	S5	0	0	55761.455	0	15105.122	9.99+	9.99+
106	11	S6	0	0	55812.805	0	15199.347	9.99+	9.99+
107	11	S7	0	0	55951.088	0	14982.599	9.99+	9.99+
108	11	S8	0	0	55493.108	0	15024.514	9.99+	9.99+



Company : Vector Structural Engineering
 Designer : STB
 Job Number : U2716.0277.211
 Model Name : Ground Mount

Sept 13, 2023
 4:04 PM
 Checked By: JSP

Slab Overturning Safety Factors (By Combination) (Continued)

LC	Slab	Angle[deg]	Mo-xx[lb-ft]	Ms-xx[lb-ft]	Mo-zz[lb-ft]	Ms-zz[lb-ft]	Ms-xx/Mo-xx	Ms-zz/Mo-zz	
109	11	S9	0	0	56106.917	0	15018.099	9.99+	9.99+
110	11	S10	0	0	55464.879	0	14942.106	9.99+	9.99+
111	12	S1	0	0	58561.598	0	14623.743	9.99+	9.99+
112	12	S2	0	0	59358.907	0	14657.637	9.99+	9.99+
113	12	S3	0	0	58878.581	0	14808.493	9.99+	9.99+
114	12	S4	0	0	58773.766	0	14535.94	9.99+	9.99+
115	12	S5	0	0	59158.672	0	14705.681	9.99+	9.99+
116	12	S6	0	0	59195.014	0	14804.408	9.99+	9.99+
117	12	S7	0	0	58773.568	0	14606.441	9.99+	9.99+
118	12	S8	0	0	58845.275	0	14617.834	9.99+	9.99+
119	12	S9	0	0	59429.415	0	14681.604	9.99+	9.99+
120	12	S10	0	0	58374.039	0	14617.766	9.99+	9.99+
121	13	S1	0	0	51416.53	0	12289.235	9.99+	9.99+
122	13	S2	0	0	51462.152	0	12267.055	9.99+	9.99+
123	13	S3	0	0	51458.607	0	12287.648	9.99+	9.99+
124	13	S4	0	0	51395.36	0	12263.946	9.99+	9.99+
125	13	S5	0	0	51479.772	0	12280.949	9.99+	9.99+
126	13	S6	0	0	51481.352	0	12287.736	9.99+	9.99+
127	13	S7	0	0	51397.537	0	12267.116	9.99+	9.99+
128	13	S8	0	0	51453.449	0	12273.956	9.99+	9.99+
129	13	S9	0	0	51470.174	0	12270.482	9.99+	9.99+
130	13	S10	0	0	51388.828	0	12274.593	9.99+	9.99+
131	14	S1	0	0	51416.53	0	12289.235	9.99+	9.99+
132	14	S2	0	0	51462.152	0	12267.055	9.99+	9.99+
133	14	S3	0	0	51458.607	0	12287.648	9.99+	9.99+
134	14	S4	0	0	51395.36	0	12263.946	9.99+	9.99+
135	14	S5	0	0	51479.772	0	12280.949	9.99+	9.99+
136	14	S6	0	0	51481.352	0	12287.736	9.99+	9.99+
137	14	S7	0	0	51397.537	0	12267.116	9.99+	9.99+
138	14	S8	0	0	51453.449	0	12273.956	9.99+	9.99+
139	14	S9	0	0	51470.174	0	12270.482	9.99+	9.99+
140	14	S10	0	0	51388.828	0	12274.593	9.99+	9.99+
141	15	S1	0	20943.631	31071.931	3211.482	7373.541	1.484	2.296
142	15	S2	0	19820.06	30948.664	3103.6	7360.233	1.561	2.372
143	15	S3	0	21451.143	31023.451	3310.298	7372.589	1.446	2.227
144	15	S4	0	19434.684	30973.073	3066.81	7358.368	1.594	2.399
145	15	S5	0	21456.01	31024.824	3304.733	7372.547	1.446	2.231
146	15	S6	0	21423.099	31025.166	3304.8	7372.642	1.448	2.231
147	15	S7	0	19512.451	30974.77	3080.2	7360.27	1.587	2.39
148	15	S8	0	21344.455	31019.456	3295.988	7371.704	1.453	2.237
149	15	S9	0	20042.519	30961.125	3136.561	7362.289	1.545	2.347
150	15	S10	0	20464.48	31050.552	3146.042	7369.494	1.517	2.342
151	16	S1	0	25082.028	31071.931	2936.798	7373.541	1.239	2.511
152	16	S2	0	23529.887	30948.664	2515.879	7360.233	1.315	2.926
153	16	S3	0	25729.122	31023.451	2751.421	7372.589	1.206	2.68
154	16	S4	0	23039.867	30973.073	2567.149	7358.368	1.344	2.866
155	16	S5	0	25698.373	31024.824	2747.728	7372.547	1.207	2.683
156	16	S6	0	25649.21	31025.166	2746.822	7372.642	1.21	2.684
157	16	S7	0	23143.668	30974.77	2574.537	7360.27	1.338	2.859
158	16	S8	0	25594.976	31019.456	2740.479	7371.704	1.212	2.69
159	16	S9	0	23796.554	30961.125	2545.628	7362.289	1.301	2.892
160	16	S10	0	24512.008	31050.552	2872.824	7369.494	1.267	2.565
161	17	S1	0	0	36416.369	0	11187.14	9.99+	9.99+
162	17	S2	0	0	37001.966	0	10996.002	9.99+	9.99+
163	17	S3	0	0	36269.884	0	11261.199	9.99+	9.99+
164	17	S4	0	0	36943.535	0	10894.205	9.99+	9.99+
165	17	S5	0	0	36596.774	0	11134.134	9.99+	9.99+



Slab Overturning Safety Factors (By Combination) (Continued)

	LC	Slab	Angle[deg]	Mo-xx[lb-ft]	Ms-xx[lb-ft]	Mo-zz[lb-ft]	Ms-zz[lb-ft]	Ms-xx/Mo-xx	Ms-zz/Mo-zz
166	17	S6	0	0	36664.082	0	11254.79	9.99+	9.99+
167	17	S7	0	0	36909.924	0	10980.913	9.99+	9.99+
168	17	S8	0	0	36258.281	0	11031.784	9.99+	9.99+
169	17	S9	0	0	37064.428	0	11025.778	9.99+	9.99+
170	17	S10	0	0	36268.032	0	10921.44	9.99+	9.99+
171	18	S1	0	0	40376.676	0	10486.218	9.99+	9.99+
172	18	S2	0	0	41406.298	0	10547.676	9.99+	9.99+
173	18	S3	0	0	40768.463	0	10733.716	9.99+	9.99+
174	18	S4	0	0	40675.091	0	10387.693	9.99+	9.99+
175	18	S5	0	0	41126.396	0	10601.545	9.99+	9.99+
176	18	S6	0	0	41173.693	0	10728.204	9.99+	9.99+
177	18	S7	0	0	40673.23	0	10479.369	9.99+	9.99+
178	18	S8	0	0	40727.838	0	10489.544	9.99+	9.99+
179	18	S9	0	0	41494.427	0	10577.119	9.99+	9.99+
180	18	S10	0	0	40146.912	0	10488.987	9.99+	9.99+
181	19	S1	0	0	30849.918	0	7373.541	9.99+	9.99+
182	19	S2	0	0	30877.291	0	7360.233	9.99+	9.99+
183	19	S3	0	0	30875.164	0	7372.589	9.99+	9.99+
184	19	S4	0	0	30837.216	0	7358.368	9.99+	9.99+
185	19	S5	0	0	30887.863	0	7368.569	9.99+	9.99+
186	19	S6	0	0	30888.811	0	7372.642	9.99+	9.99+
187	19	S7	0	0	30838.522	0	7360.27	9.99+	9.99+
188	19	S8	0	0	30872.069	0	7364.373	9.99+	9.99+
189	19	S9	0	0	30882.104	0	7362.289	9.99+	9.99+
190	19	S10	0	0	30833.297	0	7364.756	9.99+	9.99+
191	20	S1	0	0	30849.918	0	7373.541	9.99+	9.99+
192	20	S2	0	0	30877.291	0	7360.233	9.99+	9.99+
193	20	S3	0	0	30875.164	0	7372.589	9.99+	9.99+
194	20	S4	0	0	30837.216	0	7358.368	9.99+	9.99+
195	20	S5	0	0	30887.863	0	7368.569	9.99+	9.99+
196	20	S6	0	0	30888.811	0	7372.642	9.99+	9.99+
197	20	S7	0	0	30838.522	0	7360.27	9.99+	9.99+
198	20	S8	0	0	30872.069	0	7364.373	9.99+	9.99+
199	20	S9	0	0	30882.104	0	7362.289	9.99+	9.99+
200	20	S10	0	0	30833.297	0	7364.756	9.99+	9.99+

Slab Sliding Safety Factors (By Combination)

	LC	Slab	Angle[deg]	Va-xx[lb]	Vr-xx[lb]	Va-zz[lb]	Vr-zz[lb]	SR-xx	SR-zz
1	1	S1	0	1.262	2948.659	0	2948.659	9.99+	9.99+
2	1	S2	0	0	2944.093	1.078	2944.093	9.99+	9.99+
3	1	S3	0	2.471	2947.553	0	2947.553	9.99+	9.99+
4	1	S4	0	0	2943.347	0	2943.347	9.99+	9.99+
5	1	S5	0	1.326	2948.223	0	2948.223	9.99+	9.99+
6	1	S6	0	1.287	2948.285	0	2948.285	9.99+	9.99+
7	1	S7	0	1.03	2943.49	0	2943.49	9.99+	9.99+
8	1	S8	0	2.443	2947.215	0	2947.215	9.99+	9.99+
9	1	S9	0	0	2944.916	0	2944.916	9.99+	9.99+
10	1	S10	0	1.579	2946.85	0	2946.85	9.99+	9.99+
11	2	S1	0	1.262	2948.659	0	2948.659	9.99+	9.99+
12	2	S2	0	0	2944.093	1.078	2944.093	9.99+	9.99+
13	2	S3	0	2.471	2947.553	0	2947.553	9.99+	9.99+
14	2	S4	0	0	2943.347	0	2943.347	9.99+	9.99+
15	2	S5	0	1.326	2948.223	0	2948.223	9.99+	9.99+
16	2	S6	0	1.287	2948.285	0	2948.285	9.99+	9.99+
17	2	S7	0	1.03	2943.49	0	2943.49	9.99+	9.99+
18	2	S8	0	2.443	2947.215	0	2947.215	9.99+	9.99+



Company : Vector Structural Engineering
 Designer : STB
 Job Number : U2716.0277.211
 Model Name : Ground Mount

Sept 13, 2023
 4:04 PM
 Checked By: JSP

Slab Sliding Safety Factors (By Combination) (Continued)

	LC	Slab	Angle[deg]	Va-xx[lb]	Vr-xx[lb]	Va-zz[lb]	Vr-zz[lb]	SR-xx	SR-zz
19	2	S9	0	0	2944.916	0	2944.916	9.99+	9.99+
20	2	S10	0	1.579	2946.85	0	2946.85	9.99+	9.99+
21	3	S1	0	17.615	2189.23	899.029	2189.23	9.99+	2.435
22	3	S2	0	1.886	2200.361	911.173	2200.361	9.99+	2.415
23	3	S3	0	34.058	2174.999	973.89	2174.999	9.99+	2.233
24	3	S4	0	12.388	2214.745	843.363	2214.745	9.99+	2.626
25	3	S5	0	19.341	2167.487	967.244	2167.487	9.99+	2.241
26	3	S6	0	18.383	2166.935	962.778	2166.935	9.99+	2.251
27	3	S7	0	14.182	2213.369	848.944	2213.369	9.99+	2.607
28	3	S8	0	34.06	2178.08	968.873	2178.08	9.99+	2.248
29	3	S9	0	1.837	2193.243	918.375	2193.243	9.99+	2.388
30	3	S10	0	20.178	2204.854	878.664	2204.854	9.99+	2.509
31	4	S1	0	83.126	2294.461	741.955	2294.461	9.99+	3.092
32	4	S2	0	3.265	2342.241	769.472	2342.241	9.99+	3.044
33	4	S3	0	14.586	2297.446	840.208	2297.446	9.99+	2.734
34	4	S4	0	5.967	2330.812	670.148	2330.812	9.99+	3.478
35	4	S5	0	9.687	2295.376	829.01	2295.376	9.99+	2.769
36	4	S6	0	8.788	2295.092	822.513	2295.092	9.99+	2.79
37	4	S7	0	5.797	2329.697	677.465	2329.697	9.99+	3.439
38	4	S8	0	15.044	2299.993	834.815	2299.993	9.99+	2.755
39	4	S9	0	2.595	2335.522	774.508	2335.522	9.99+	3.015
40	4	S10	0	82.661	2307.916	725.69	2307.916	9.99+	3.18
41	5	S1	0	33.983	3844.291	1055.278	3844.291	9.99+	3.643
42	5	S2	0	2.377	3815.251	1069.845	3815.251	9.99+	3.566
43	5	S3	0	43.338	3856.299	1148.749	3856.299	9.99+	3.357
44	5	S4	0	13.923	3800.302	985.967	3800.302	9.99+	3.854
45	5	S5	0	24.656	3865.957	1140.071	3865.957	9.99+	3.391
46	5	S6	0	23.43	3866.714	1134.397	3866.714	9.99+	3.409
47	5	S7	0	18.055	3802.229	992.934	3802.229	9.99+	3.829
48	5	S8	0	43.351	3851.938	1142.667	3851.938	9.99+	3.371
49	5	S9	0	2.322	3825.546	1080.533	3825.546	9.99+	3.54
50	5	S10	0	37.294	3821.883	1031.457	3821.883	9.99+	3.705
51	6	S1	0	17.609	3707.025	915.764	3707.025	9.99+	4.048
52	6	S2	0	1.333	3708.28	916.374	3708.28	9.99+	4.047
53	6	S3	0	46.927	3727.55	971.824	3727.55	9.99+	3.836
54	6	S4	0	14.845	3679.292	873.384	3679.292	9.99+	4.213
55	6	S5	0	25.723	3738.776	968.218	3738.776	9.99+	3.862
56	6	S6	0	24.733	3739.552	965.225	3739.552	9.99+	3.874
57	6	S7	0	19.518	3680.981	877.567	3680.981	9.99+	4.195
58	6	S8	0	46.623	3723.764	967.406	3723.764	9.99+	3.849
59	6	S9	0	0.28	3716.643	926.285	3716.643	9.99+	4.012
60	6	S10	0	12.959	3687.942	894.719	3687.942	9.99+	4.122
61	7	S1	0	1.262	2948.659	0	2948.659	9.99+	9.99+
62	7	S2	0	0	2944.093	1.078	2944.093	9.99+	9.99+
63	7	S3	0	2.471	2947.553	0	2947.553	9.99+	9.99+
64	7	S4	0	0	2943.347	0	2943.347	9.99+	9.99+
65	7	S5	0	1.326	2948.223	0	2948.223	9.99+	9.99+
66	7	S6	0	1.287	2948.285	0	2948.285	9.99+	9.99+
67	7	S7	0	1.03	2943.49	0	2943.49	9.99+	9.99+
68	7	S8	0	2.443	2947.215	0	2947.215	9.99+	9.99+
69	7	S9	0	0	2944.916	0	2944.916	9.99+	9.99+
70	7	S10	0	1.579	2946.85	0	2946.85	9.99+	9.99+
71	8	S1	0	1.262	2948.659	0	2948.659	9.99+	9.99+
72	8	S2	0	0	2944.093	1.078	2944.093	9.99+	9.99+
73	8	S3	0	2.471	2947.553	0	2947.553	9.99+	9.99+
74	8	S4	0	0	2943.347	0	2943.347	9.99+	9.99+
75	8	S5	0	1.326	2948.223	0	2948.223	9.99+	9.99+



Company : Vector Structural Engineering
 Designer : STB
 Job Number : U2716.0277.211
 Model Name : Ground Mount

Sept 13, 2023
 4:04 PM
 Checked By: JSP

Slab Sliding Safety Factors (By Combination) (Continued)

	LC	Slab	Angle[deg]	Va-xx[lb]	Vr-xx[lb]	Va-zz[lb]	Vr-zz[lb]	SR-xx	SR-zz
76	8	S6	0	1.287	2948.285	0	2948.285	9.99+	9.99+
77	8	S7	0	1.03	2943.49	0	2943.49	9.99+	9.99+
78	8	S8	0	2.443	2947.215	0	2947.215	9.99+	9.99+
79	8	S9	0	0	2944.916	0	2944.916	9.99+	9.99+
80	8	S10	0	1.579	2946.85	0	2946.85	9.99+	9.99+
81	9	S1	0	12.896	2379.087	674.272	2379.087	9.99+	3.528
82	9	S2	0	1.415	2386.294	683.649	2386.294	9.99+	3.491
83	9	S3	0	24.926	2368.137	730.418	2368.137	9.99+	3.242
84	9	S4	0	9.291	2396.896	632.522	2396.896	9.99+	3.789
85	9	S5	0	14.174	2362.671	725.433	2362.671	9.99+	3.257
86	9	S6	0	13.466	2362.272	722.083	2362.272	9.99+	3.271
87	9	S7	0	10.379	2395.899	636.708	2395.899	9.99+	3.763
88	9	S8	0	24.934	2370.364	726.654	2370.364	9.99+	3.262
89	9	S9	0	1.378	2381.161	688.781	2381.161	9.99+	3.457
90	9	S10	0	14.739	2390.353	658.998	2390.353	9.99+	3.627
91	10	S1	0	62.029	2458.011	556.466	2458.011	9.99+	4.417
92	10	S2	0	2.449	2492.704	577.374	2492.704	9.99+	4.317
93	10	S3	0	10.322	2459.973	630.156	2459.973	9.99+	3.904
94	10	S4	0	4.476	2483.945	502.611	2483.945	9.99+	4.942
95	10	S5	0	6.934	2458.588	621.758	2458.588	9.99+	3.954
96	10	S6	0	6.269	2458.39	616.885	2458.39	9.99+	3.985
97	10	S7	0	4.09	2483.145	508.099	2483.145	9.99+	4.887
98	10	S8	0	10.672	2461.799	626.112	2461.799	9.99+	3.932
99	10	S9	0	1.946	2487.87	580.881	2487.87	9.99+	4.283
100	10	S10	0	61.601	2467.65	544.268	2467.65	9.99+	4.534
101	11	S1	0	25.802	3620.383	791.459	3620.383	9.99+	4.574
102	11	S2	0	1.783	3597.462	802.114	3597.462	9.99+	4.485
103	11	S3	0	33.121	3629.113	861.562	3629.113	9.99+	4.212
104	11	S4	0	10.443	3586.063	739.475	3586.063	9.99+	4.849
105	11	S5	0	18.824	3636.523	855.053	3636.523	9.99+	4.253
106	11	S6	0	17.894	3637.107	850.798	3637.107	9.99+	4.275
107	11	S7	0	13.799	3587.545	744.7	3587.545	9.99+	4.817
108	11	S8	0	33.124	3625.758	857	3625.758	9.99+	4.231
109	11	S9	0	1.741	3605.388	810.4	3605.388	9.99+	4.449
110	11	S10	0	28.365	3603.124	773.593	3603.124	9.99+	4.658
111	12	S1	0	12.892	3517.433	686.823	3517.433	9.99+	5.121
112	12	S2	0	1	3517.233	687.011	3517.233	9.99+	5.12
113	12	S3	0	35.813	3532.551	728.868	3532.551	9.99+	4.847
114	12	S4	0	11.133	3495.306	655.038	3495.306	9.99+	5.336
115	12	S5	0	19.624	3541.138	726.163	3541.138	9.99+	4.877
116	12	S6	0	18.872	3541.735	723.919	3541.735	9.99+	4.892
117	12	S7	0	14.896	3496.608	658.175	3496.608	9.99+	5.313
118	12	S8	0	35.578	3529.627	725.555	3529.627	9.99+	4.865
119	12	S9	0	0.21	3523.711	694.714	3523.711	9.99+	5.072
120	12	S10	0	9.325	3502.669	671.04	3502.669	9.99+	5.22
121	13	S1	0	1.262	2948.659	0	2948.659	9.99+	9.99+
122	13	S2	0	0	2944.093	1.078	2944.093	9.99+	9.99+
123	13	S3	0	2.471	2947.553	0	2947.553	9.99+	9.99+
124	13	S4	0	0	2943.347	0	2943.347	9.99+	9.99+
125	13	S5	0	1.326	2948.223	0	2948.223	9.99+	9.99+
126	13	S6	0	1.287	2948.285	0	2948.285	9.99+	9.99+
127	13	S7	0	1.03	2943.49	0	2943.49	9.99+	9.99+
128	13	S8	0	2.443	2947.215	0	2947.215	9.99+	9.99+
129	13	S9	0	0	2944.916	0	2944.916	9.99+	9.99+
130	13	S10	0	1.579	2946.85	0	2946.85	9.99+	9.99+
131	14	S1	0	1.262	2948.659	0	2948.659	9.99+	9.99+
132	14	S2	0	0	2944.093	1.078	2944.093	9.99+	9.99+



Company : Vector Structural Engineering
 Designer : STB
 Job Number : U2716.0277.211
 Model Name : Ground Mount

Sept 13, 2023
 4:04 PM
 Checked By: JSP

Slab Sliding Safety Factors (By Combination) (Continued)

	LC	Slab	Angle[deg]	Va-xx[lb]	Vr-xx[lb]	Va-zz[lb]	Vr-zz[lb]	SR-xx	SR-zz
133	14	S3	0	2.471	2947.553	0	2947.553	9.99+	9.99+
134	14	S4	0	0	2943.347	0	2943.347	9.99+	9.99+
135	14	S5	0	1.326	2948.223	0	2948.223	9.99+	9.99+
136	14	S6	0	1.287	2948.285	0	2948.285	9.99+	9.99+
137	14	S7	0	1.03	2943.49	0	2943.49	9.99+	9.99+
138	14	S8	0	2.443	2947.215	0	2947.215	9.99+	9.99+
139	14	S9	0	0	2944.916	0	2944.916	9.99+	9.99+
140	14	S10	0	1.579	2946.85	0	2946.85	9.99+	9.99+
141	15	S1	0	18.12	1009.766	899.029	1009.766	9.99+	1.123
142	15	S2	0	1.886	1022.724	910.741	1022.724	9.99+	1.123
143	15	S3	0	35.046	995.977	973.89	995.977	9.99+	1.023
144	15	S4	0	12.388	1037.407	843.363	1037.407	9.99+	1.23
145	15	S5	0	19.871	988.198	967.244	988.198	9.99+	1.022
146	15	S6	0	18.898	987.621	962.778	987.621	9.99+	1.026
147	15	S7	0	14.594	1035.973	848.944	1035.973	9.99+	1.22
148	15	S8	0	35.037	999.194	968.873	999.194	9.99+	1.031
149	15	S9	0	1.837	1015.277	918.375	1015.277	9.99+	1.106
150	15	S10	0	20.81	1026.114	878.664	1026.114	9.99+	1.168
151	16	S1	0	83.631	1114.997	741.955	1114.997	9.99+	1.503
152	16	S2	0	3.265	1164.604	769.041	1164.604	9.99+	1.514
153	16	S3	0	15.574	1118.425	840.208	1118.425	9.99+	1.331
154	16	S4	0	5.967	1153.473	670.148	1153.473	9.99+	1.721
155	16	S5	0	10.217	1116.087	829.01	1116.087	9.99+	1.346
156	16	S6	0	9.303	1115.778	822.513	1115.778	9.99+	1.357
157	16	S7	0	6.209	1152.301	677.465	1152.301	9.99+	1.701
158	16	S8	0	16.022	1121.107	834.815	1121.107	9.99+	1.343
159	16	S9	0	2.595	1157.556	774.508	1157.556	9.99+	1.495
160	16	S10	0	83.292	1129.176	725.69	1129.176	9.99+	1.556
161	17	S1	0	33.478	2664.827	1055.278	2664.827	9.99+	2.525
162	17	S2	0	2.377	2637.614	1070.276	2637.614	9.99+	2.464
163	17	S3	0	42.35	2677.278	1148.749	2677.278	9.99+	2.331
164	17	S4	0	13.923	2622.963	985.967	2622.963	9.99+	2.66
165	17	S5	0	24.126	2686.668	1140.071	2686.668	9.99+	2.357
166	17	S6	0	22.915	2687.4	1134.397	2687.4	9.99+	2.369
167	17	S7	0	17.643	2624.833	992.934	2624.833	9.99+	2.644
168	17	S8	0	42.373	2673.052	1142.667	2673.052	9.99+	2.339
169	17	S9	0	2.322	2647.58	1080.533	2647.58	9.99+	2.45
170	17	S10	0	36.662	2643.143	1031.457	2643.143	9.99+	2.563
171	18	S1	0	18.114	2527.561	915.764	2527.561	9.99+	2.76
172	18	S2	0	1.333	2530.642	916.805	2530.642	9.99+	2.76
173	18	S3	0	45.938	2548.529	971.824	2548.529	9.99+	2.622
174	18	S4	0	14.845	2501.953	873.384	2501.953	9.99+	2.865
175	18	S5	0	25.193	2559.486	968.218	2559.486	9.99+	2.644
176	18	S6	0	24.219	2560.238	965.225	2560.238	9.99+	2.652
177	18	S7	0	19.106	2503.585	877.567	2503.585	9.99+	2.853
178	18	S8	0	45.646	2544.878	967.406	2544.878	9.99+	2.631
179	18	S9	0	0.28	2538.676	926.285	2538.676	9.99+	2.741
180	18	S10	0	13.591	2509.202	894.719	2509.202	9.99+	2.804
181	19	S1	0	0.757	1769.196	0	1769.196	9.99+	9.99+
182	19	S2	0	0	1766.456	0.647	1766.456	9.99+	9.99+
183	19	S3	0	1.482	1768.532	0	1768.532	9.99+	9.99+
184	19	S4	0	0	1766.008	0	1766.008	9.99+	9.99+
185	19	S5	0	0.795	1768.934	0	1768.934	9.99+	9.99+
186	19	S6	0	0.772	1768.971	0	1768.971	9.99+	9.99+
187	19	S7	0	0.618	1766.094	0	1766.094	9.99+	9.99+
188	19	S8	0	1.466	1768.329	0	1768.329	9.99+	9.99+
189	19	S9	0	0	1766.949	0	1766.949	9.99+	9.99+



Company : Vector Structural Engineering
 Designer : STB
 Job Number : U2716.0277.211
 Model Name : Ground Mount

Sept 13, 2023
 4:04 PM
 Checked By: JSP

Slab Sliding Safety Factors (By Combination) (Continued)

	LC	Slab	Angle[deg]	Va-xx[lb]	Vr-xx[lb]	Va-zz[lb]	Vr-zz[lb]	SR-xx	SR-zz
190	19	S10	0	0.948	1768.11	0	1768.11	9.99+	9.99+
191	20	S1	0	0.757	1769.196	0	1769.196	9.99+	9.99+
192	20	S2	0	0	1766.456	0.647	1766.456	9.99+	9.99+
193	20	S3	0	1.482	1768.532	0	1768.532	9.99+	9.99+
194	20	S4	0	0	1766.008	0	1766.008	9.99+	9.99+
195	20	S5	0	0.795	1768.934	0	1768.934	9.99+	9.99+
196	20	S6	0	0.772	1768.971	0	1768.971	9.99+	9.99+
197	20	S7	0	0.618	1766.094	0	1766.094	9.99+	9.99+
198	20	S8	0	1.466	1768.329	0	1768.329	9.99+	9.99+
199	20	S9	0	0	1766.949	0	1766.949	9.99+	9.99+
200	20	S10	0	0.948	1768.11	0	1768.11	9.99+	9.99+

Envelope Slab Soil Pressures

	Label	Max UC	Max LC	Soil Pressure[psf]	Allowable Bearing[psf]	Point
1	S1	0.435	5	652.663	1500	N1
2	S2	0.416	5	624.417	1500	N27
3	S3	0.438	5	656.467	1500	N31
4	S4	0.415	5	623.213	1500	N35
5	S5	0.436	5	654.614	1500	N39
6	S6	0.436	5	653.846	1500	N42
7	S7	0.416	5	624.508	1500	N47
8	S8	0.437	5	654.896	1500	N51
9	S9	0.418	5	627.61	1500	N55
10	S10	0.431	5	646.096	1500	N59



Company:		Date:	9/13/2023
Engineer:		Page:	1/6
Project:			
Address:			
Phone:			
E-mail:			

1. Project information

Customer company:
Customer contact name:
Customer e-mail:
Comment:

Project description:
Location:
Fastening description:

2. Input Data & Anchor Parameters

General

Design method: ACI 318-14
Units: Imperial units

Anchor Information:

Anchor type: Bonded anchor
Material: F1554 Grade 36
Diameter (inch): 0.375
Effective Embedment depth, h_{ef} (inch): 4.000
Code report: ICC-ES ESR-4057
Anchor category: -
Anchor ductility: Yes
 h_{min} (inch): 5.25
 c_{ac} (inch): 7.12
 C_{min} (inch): 1.75
 S_{min} (inch): 1.00

Base Material

Concrete: Normal-weight
Concrete thickness, h (inch): 30.00
State: Cracked
Compressive strength, f'_c (psi): 2500
 $\Psi_{c,v}$: 1.0
Reinforcement condition: B tension, B shear
Supplemental reinforcement: Not applicable
Reinforcement provided at corners: No
Ignore concrete breakout in tension: No
Ignore concrete breakout in shear: No
Hole condition: Dry concrete
Inspection: Continuous
Temperature range, Short/Long: 150/110°F
Ignore 6do requirement: Not applicable
Build-up grout pad: No

Base Plate

Length x Width x Thickness (inch): 4.75 x 4.75 x 0.25

Recommended Anchor

Anchor Name: SET-3G - SET-3G w/ 3/8"Ø F1554 Gr. 36
Code Report: ICC-ES ESR-4057





Company:		Date:	9/13/2023
Engineer:		Page:	2/6
Project:			
Address:			
Phone:			
E-mail:			

Load and Geometry

Load factor source: ACI 318 Section 5.3

Load combination: not set

Seismic design: No

Anchors subjected to sustained tension: No

Apply entire shear load at front row: No

Anchors only resisting wind and/or seismic loads: No

Strength level loads:

N_{ua} [lb]: 4118

V_{uax} [lb]: 153

V_{uay} [lb]: -2030

M_{ux} [ft-lb]: 0

M_{uy} [ft-lb]: 0

M_{uz} [ft-lb]: 0

<Figure 1>

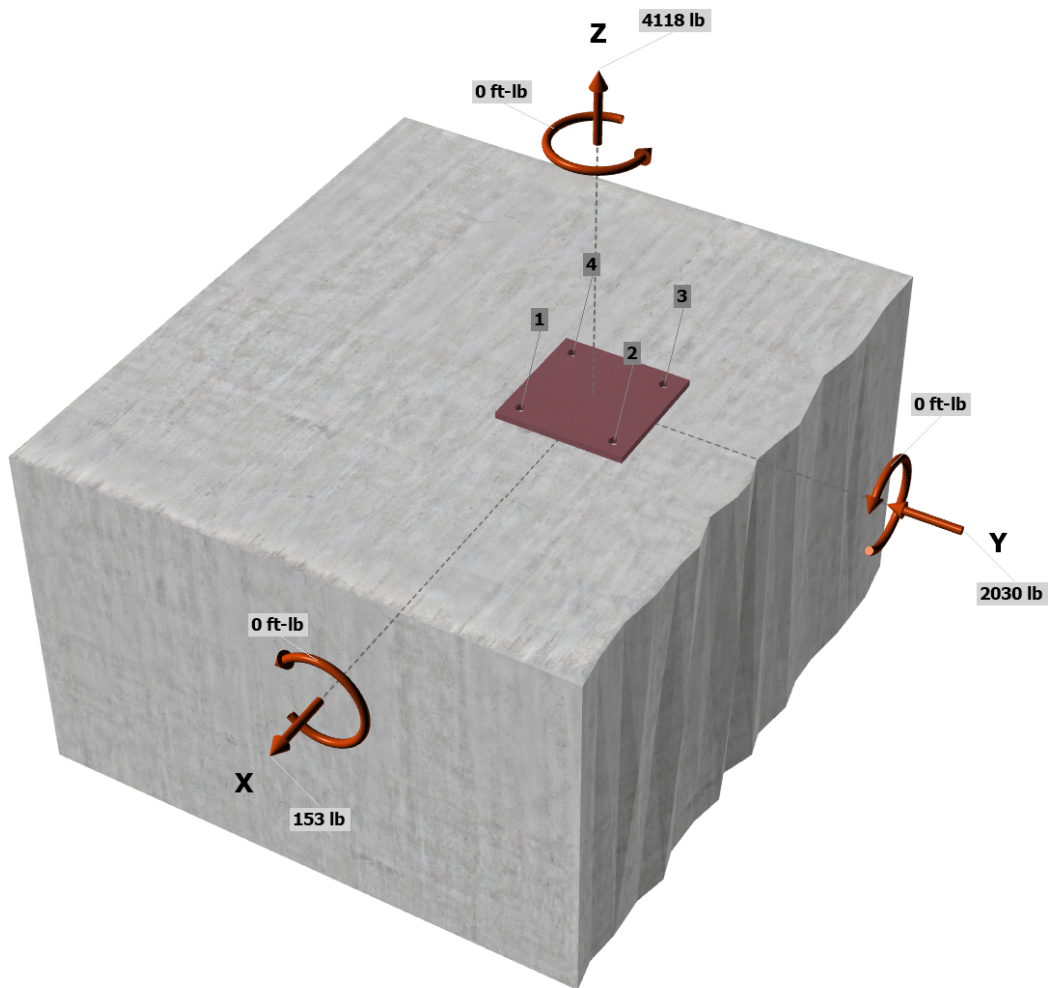



Company:		Date:	9/13/2023
Engineer:		Page:	3/6
Project:			
Address:			
Phone:			
E-mail:			

<Figure 2>

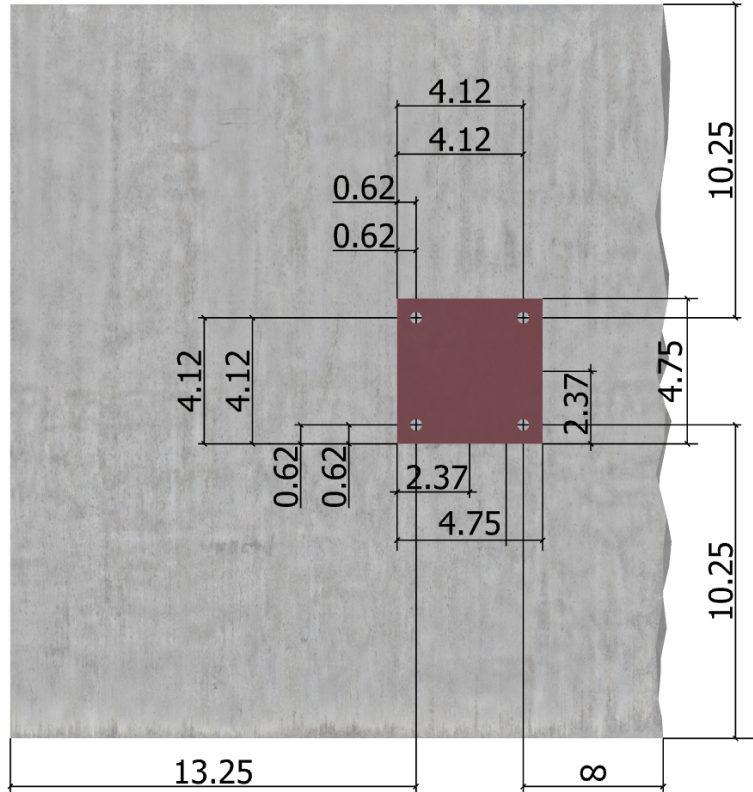



Company:		Date:	9/13/2023
Engineer:		Page:	4/6
Project:			
Address:			
Phone:			
E-mail:			

3. Resulting Anchor Forces

Anchor	Tension load, N _{ua} (lb)	Shear load x, V _{uax} (lb)	Shear load y, V _{uay} (lb)	Shear load combined, $\sqrt{(V_{uax})^2 + (V_{uay})^2}$ (lb)
1	1029.5	38.3	-507.5	508.9
2	1029.5	38.2	-507.5	508.9
3	1029.5	38.2	-507.5	508.9
4	1029.5	38.3	-507.5	509.0
Sum	4118.0	153.0	-2030.0	2035.8

Maximum concrete compression strain (%): 0.00
 Maximum concrete compression stress (psi): 0
 Resultant tension force (lb): 4118
 Resultant compression force (lb): 0
 Eccentricity of resultant tension forces in x-axis, e'_{Nx} (inch): 0.00
 Eccentricity of resultant tension forces in y-axis, e'_{Ny} (inch): 0.00
 Eccentricity of resultant shear forces in x-axis, e'_{Vx} (inch): 0.00
 Eccentricity of resultant shear forces in y-axis, e'_{Vy} (inch): 0.00

<Figure 3>

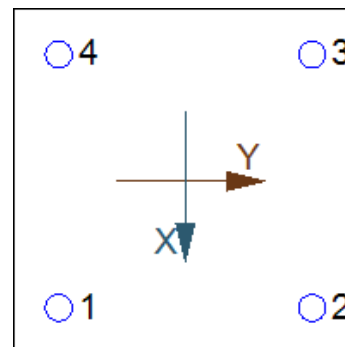

4. Steel Strength of Anchor in Tension (Sec. 17.4.1)

N _{sa} (lb)	φ	φN _{sa} (lb)
4525	0.75	3394

5. Concrete Breakout Strength of Anchor in Tension (Sec. 17.4.2)

$$N_b = K_c \lambda_a \sqrt{f'_c} h_{ef}^{1.5} \text{ (Eq. 17.4.2.2a)}$$

K _c	λ _a	f' _c (psi)	h _{ef} (in)	N _b (lb)
17.0	1.00	2500	4.000	6800

$$\phi N_{cbg} = \phi (A_{Nc} / A_{Nco}) \Psi_{ec,N} \Psi_{ed,N} \Psi_{c,N} \Psi_{cp,N} N_b \text{ (Sec. 17.3.1 \& Eq. 17.4.2.1b)}$$

A _{Nc} (in ²)	A _{Nco} (in ²)	C _{a,min} (in)	Ψ _{ec,N}	Ψ _{ed,N}	Ψ _{c,N}	Ψ _{cp,N}	N _b (lb)	φ	φN _{cbg} (lb)
240.25	144.00	10.25	1.000	1.000	1.00	1.000	6800	0.65	7374

6. Adhesive Strength of Anchor in Tension (Sec. 17.4.5)

$$\tau_{k,cr} = \tau_{k,cr,short-term} K_{sat} (f'_c / 2,500)^0$$

τ _{k,cr} (psi)	f _{short-term}	K _{sat}	f' _c (psi)	n	τ _{k,cr} (psi)
1448	1.00	1.00	2500	0.24	1448

$$N_{ba} = \lambda_a \tau_{cr} \pi d_a h_{ef} \text{ (Eq. 17.4.5.2)}$$

λ _a	τ _{cr} (psi)	d _a (in)	h _{ef} (in)	N _{ba} (lb)
1.00	1448	0.38	4.000	6824

$$\phi N_{ag} = \phi (A_{Na} / A_{Na0}) \Psi_{ec,Na} \Psi_{ed,Na} \Psi_{cp,Na} N_{ba} \text{ (Sec. 17.3.1 \& Eq. 17.4.5.1b)}$$

A _{Na} (in ²)	A _{Na0} (in ²)	C _{Na} (in)	C _{a,min} (in)	Ψ _{ec,Na}	Ψ _{ed,Na}	Ψ _{cp,Na}	N _{ba} (lb)	φ	φN _{ag} (lb)
209.63	120.53	5.49	10.25	1.000	1.000	1.000	6824	0.65	7714



Company:		Date:	9/13/2023
Engineer:		Page:	5/6
Project:			
Address:			
Phone:			
E-mail:			

8. Steel Strength of Anchor in Shear (Sec. 17.5.1)

V_{sa} (lb)	ϕ_{grout}	ϕ	$\phi_{grout}\phi V_{sa}$ (lb)
2715	1.0	0.65	1765

9. Concrete Breakout Strength of Anchor in Shear (Sec. 17.5.2)

Shear perpendicular to edge in x-direction:

$V_{bx} = \min|7(l_e / d_a)^{0.2} \sqrt{d_a} \lambda_a \sqrt{f_c} c_{a1}^{1.5}; 9 \lambda_a \sqrt{f_c} c_{a1}^{1.5}|$ (Eq. 17.5.2.2a & Eq. 17.5.2.2b)

l_e (in)	d_a (in)	λ_a	f_c (psi)	c_{a1} (in)	V_{bx} (lb)
3.00	0.375	1.00	2500	13.75	16564

$\phi V_{cbgx} = \phi (A_{vc} / A_{vco}) \Psi_{ec,v} \Psi_{ed,v} \Psi_{c,v} \Psi_{h,v} V_{bx}$ (Sec. 17.3.1 & Eq. 17.5.2.1b)

A_{vc} (in ²)	A_{vco} (in ²)	$\Psi_{ec,v}$	$\Psi_{ed,v}$	$\Psi_{c,v}$	$\Psi_{h,v}$	V_{bx} (lb)	ϕ	ϕV_{cbgx} (lb)
770.86	850.78	1.000	0.893	1.000	1.000	16564	0.70	9378

Shear perpendicular to edge in y-direction:

$V_{by} = \min|7(l_e / d_a)^{0.2} \sqrt{d_a} \lambda_a \sqrt{f_c} c_{a1}^{1.5}; 9 \lambda_a \sqrt{f_c} c_{a1}^{1.5}|$ (Eq. 17.5.2.2a & Eq. 17.5.2.2b)

l_e (in)	d_a (in)	λ_a	f_c (psi)	c_{a1} (in)	V_{by} (lb)
3.00	0.375	1.00	2500	16.75	22270

$\phi V_{cbgy} = \phi (A_{vc} / A_{vco}) \Psi_{ec,v} \Psi_{ed,v} \Psi_{c,v} \Psi_{h,v} V_{by}$ (Sec. 17.3.1 & Eq. 17.5.2.1b)

A_{vc} (in ²)	A_{vco} (in ²)	$\Psi_{ec,v}$	$\Psi_{ed,v}$	$\Psi_{c,v}$	$\Psi_{h,v}$	V_{by} (lb)	ϕ	ϕV_{cbgy} (lb)
603.00	1262.53	1.000	0.822	1.000	1.000	22270	0.70	6123

Shear parallel to edge in y-direction:

$V_{bx} = \min|7(l_e / d_a)^{0.2} \sqrt{d_a} \lambda_a \sqrt{f_c} c_{a1}^{1.5}; 9 \lambda_a \sqrt{f_c} c_{a1}^{1.5}|$ (Eq. 17.5.2.2a & Eq. 17.5.2.2b)

l_e (in)	d_a (in)	λ_a	f_c (psi)	c_{a1} (in)	V_{bx} (lb)
3.00	0.375	1.00	2500	13.25	15668

$\phi V_{cbgy} = \phi (2)(A_{vc} / A_{vco}) \Psi_{ec,v} \Psi_{ed,v} \Psi_{c,v} \Psi_{h,v} V_{bx}$ (Sec. 17.3.1, 17.5.2.1(c) & Eq. 17.5.2.1b)

A_{vc} (in ²)	A_{vco} (in ²)	$\Psi_{ec,v}$	$\Psi_{ed,v}$	$\Psi_{c,v}$	$\Psi_{h,v}$	V_{bx} (lb)	ϕ	ϕV_{cbgy} (lb)
477.00	790.03	1.000	1.000	1.000	1.000	15668	0.70	13244

Shear parallel to edge in x-direction:

$V_{by} = \min|7(l_e / d_a)^{0.2} \sqrt{d_a} \lambda_a \sqrt{f_c} c_{a1}^{1.5}; 9 \lambda_a \sqrt{f_c} c_{a1}^{1.5}|$ (Eq. 17.5.2.2a & Eq. 17.5.2.2b)

l_e (in)	d_a (in)	λ_a	f_c (psi)	c_{a1} (in)	V_{by} (lb)
3.00	0.375	1.00	2500	10.25	10661

$\phi V_{cbgx} = \phi (2)(A_{vc} / A_{vco}) \Psi_{ec,v} \Psi_{ed,v} \Psi_{c,v} \Psi_{h,v} V_{by}$ (Sec. 17.3.1, 17.5.2.1(c) & Eq. 17.5.2.1b)

A_{vc} (in ²)	A_{vco} (in ²)	$\Psi_{ec,v}$	$\Psi_{ed,v}$	$\Psi_{c,v}$	$\Psi_{h,v}$	V_{by} (lb)	ϕ	ϕV_{cbgx} (lb)
493.92	472.78	1.000	1.000	1.000	1.000	10661	0.70	15592

10. Concrete Pryout Strength of Anchor in Shear (Sec. 17.5.3)

$\phi V_{cp} = \phi \min|k_{cp} N_{ba}; k_{cp} N_{cb}| = \phi \min|k_{cp} (A_{Na} / A_{Na0}) \Psi_{ec,Na} \Psi_{ed,Na} \Psi_{c,Na} N_{ba}; k_{cp} (A_{Nc} / A_{Nco}) \Psi_{ec,N} \Psi_{ed,N} \Psi_{c,N} \Psi_{cp,N} N_b|$ (Sec. 17.3.1 & Eq. 17.5.3.1b)

k_{cp}	A_{Na} (in ²)	A_{Na0} (in ²)	$\Psi_{ed,Na}$	$\Psi_{ec,Na}$	$\Psi_{c,Na}$	N_{ba} (lb)	N_a (lb)
2.0	209.63	120.53	1.000	1.000	1.000	6824	11868

A_{Nc} (in ²)	A_{Nco} (in ²)	$\Psi_{ec,N}$	$\Psi_{ed,N}$	$\Psi_{c,N}$	$\Psi_{cp,N}$	N_b (lb)	N_{cb} (lb)	ϕ
240.25	144.00	1.000	1.000	1.000	1.000	6800	11345	0.70

Input data and results must be checked for agreement with the existing circumstances, the standards and guidelines must be checked for plausibility.



Company:		Date:	9/13/2023
Engineer:		Page:	6/6
Project:			
Address:			
Phone:			
E-mail:			

ϕV_{cpg} (lb)
15883

11. Results

Interaction of Tensile and Shear Forces (Sec. 17.6.)

Tension	Factored Load, N_{ua} (lb)	Design Strength, ϕN_n (lb)	Ratio	Status	
Steel	1030	3394	0.30	Pass	
Concrete breakout	4118	7374	0.56	Pass (Governs)	
Adhesive	4118	7714	0.53	Pass	
Shear	Factored Load, V_{ua} (lb)	Design Strength, ϕV_n (lb)	Ratio	Status	
Steel	509	1765	0.29	Pass	
T Concrete breakout x+	153	9378	0.02	Pass	
T Concrete breakout y-	2030	6123	0.33	Pass	
Concrete breakout y-	77	13244	0.01	Pass	
Concrete breakout x-	1015	15592	0.07	Pass	
Concrete breakout, combined	-	-	0.33	Pass (Governs)	
Pryout	2036	15883	0.13	Pass	
Interaction check	$N_{ua}/\phi N_n$	$V_{ua}/\phi V_n$	Combined Ratio	Permissible	Status
Sec. 17.6..1	0.56	0.00	55.8%	1.0	Pass

SET-3G w/ 3/8"Ø F1554 Gr. 36 with hef = 4.000 inch meets the selected design criteria.

12. Warnings

- Designer must exercise own judgement to determine if this design is suitable.
- Refer to manufacturer's product literature for hole cleaning and installation instructions.



JOB NO.: U2716-0277-211

DESIGNED: STB

Framing Analysis

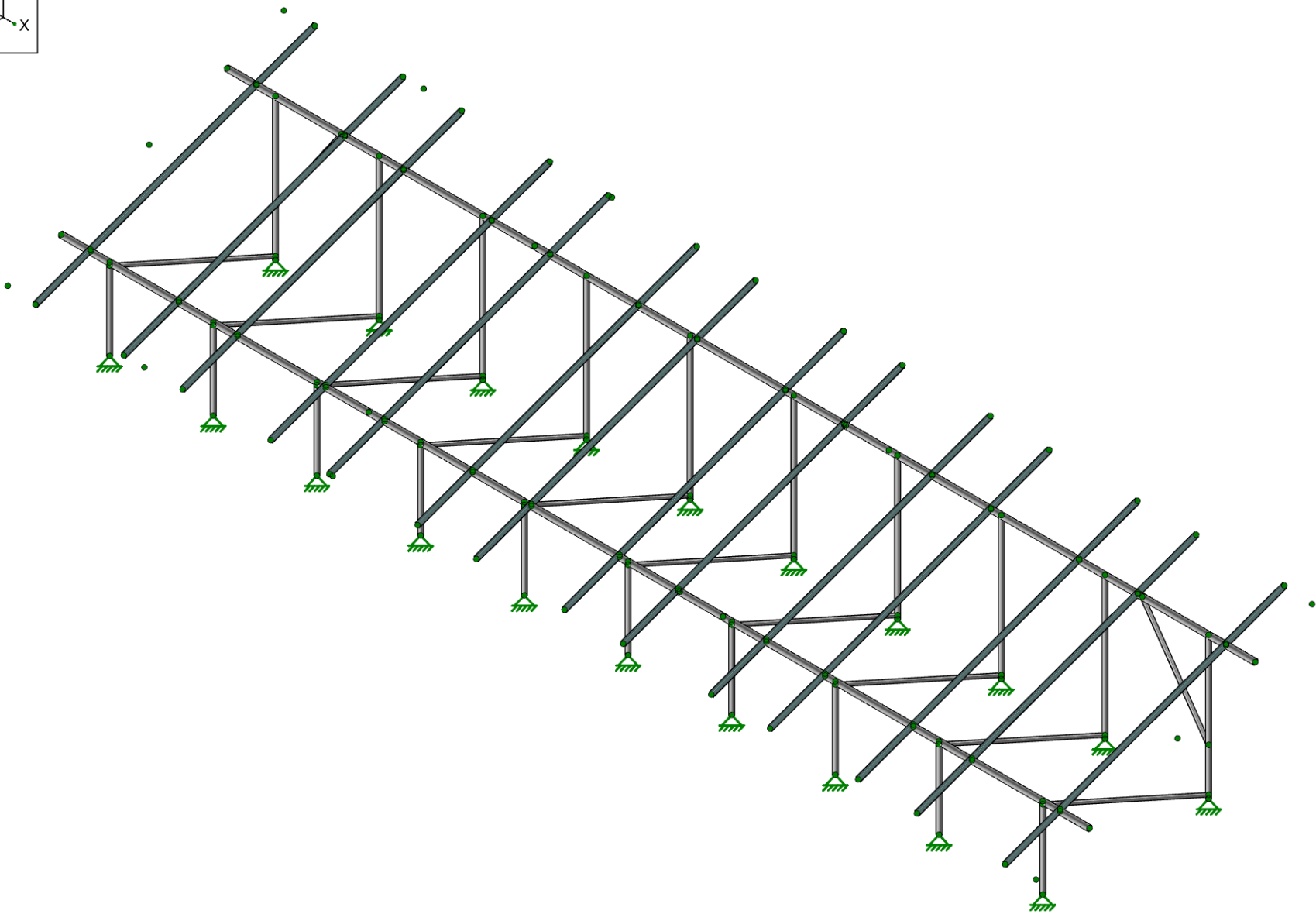
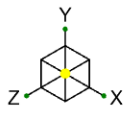

Vector Structural Engineering
STB
U2716.0277.211

Ground Mount

SK-1
Sep 13, 2023 at 04:10 PM
Sunmodo Sunturf D3 GM v2 85x45 - MI...

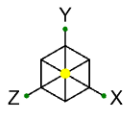

Section Sets

- █ Post
- █ Cross Beam
- █ Diagonal Brace
- █ RIGID
- █ AL Rails

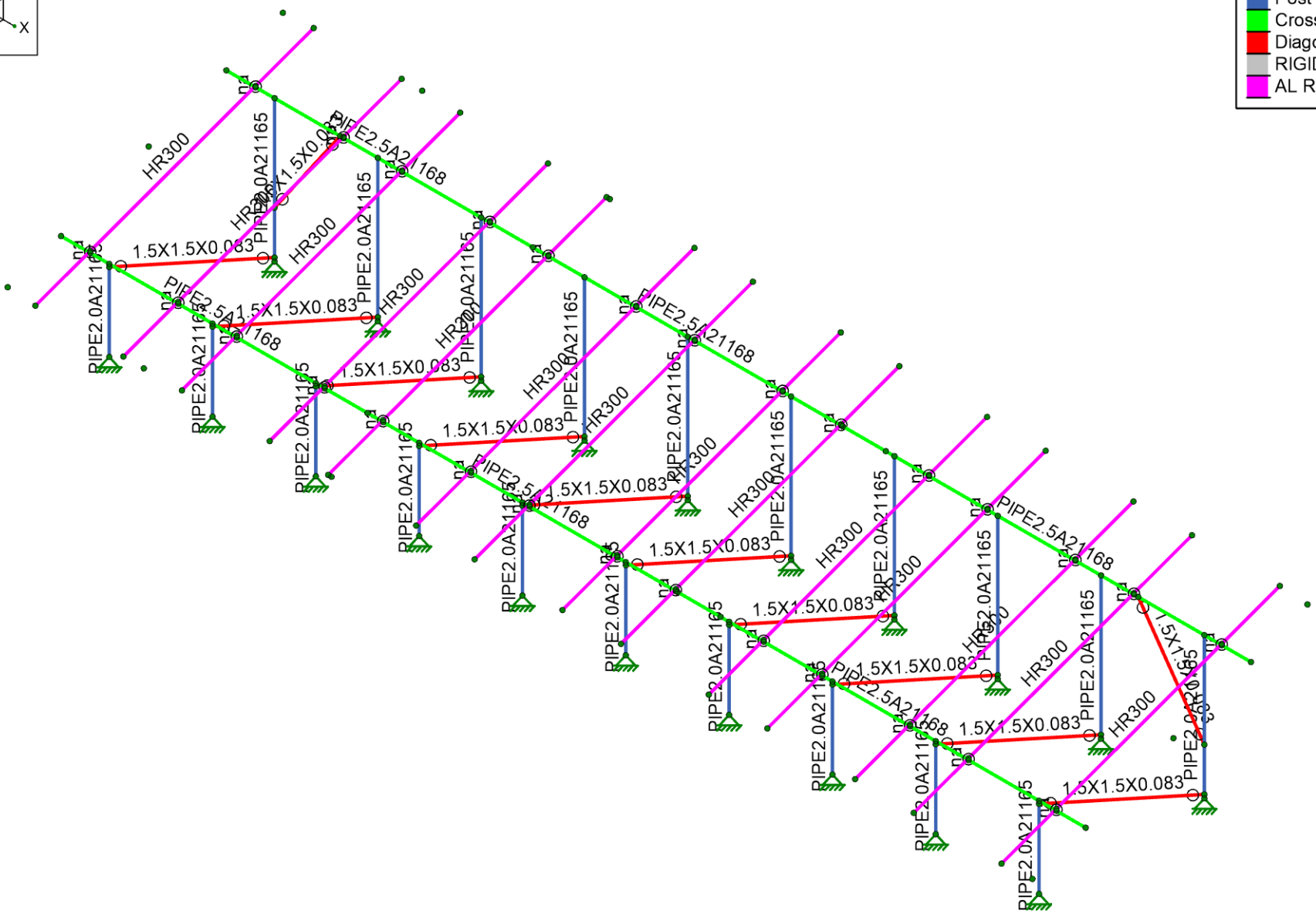

Vector Structural Engineering
 STB
 U2716.0277.211

Ground Mount

SK-2
 Sep 13, 2023 at 04:10 PM
 Sunmodo Sunturf D3 GM v2 85x45 - MI...

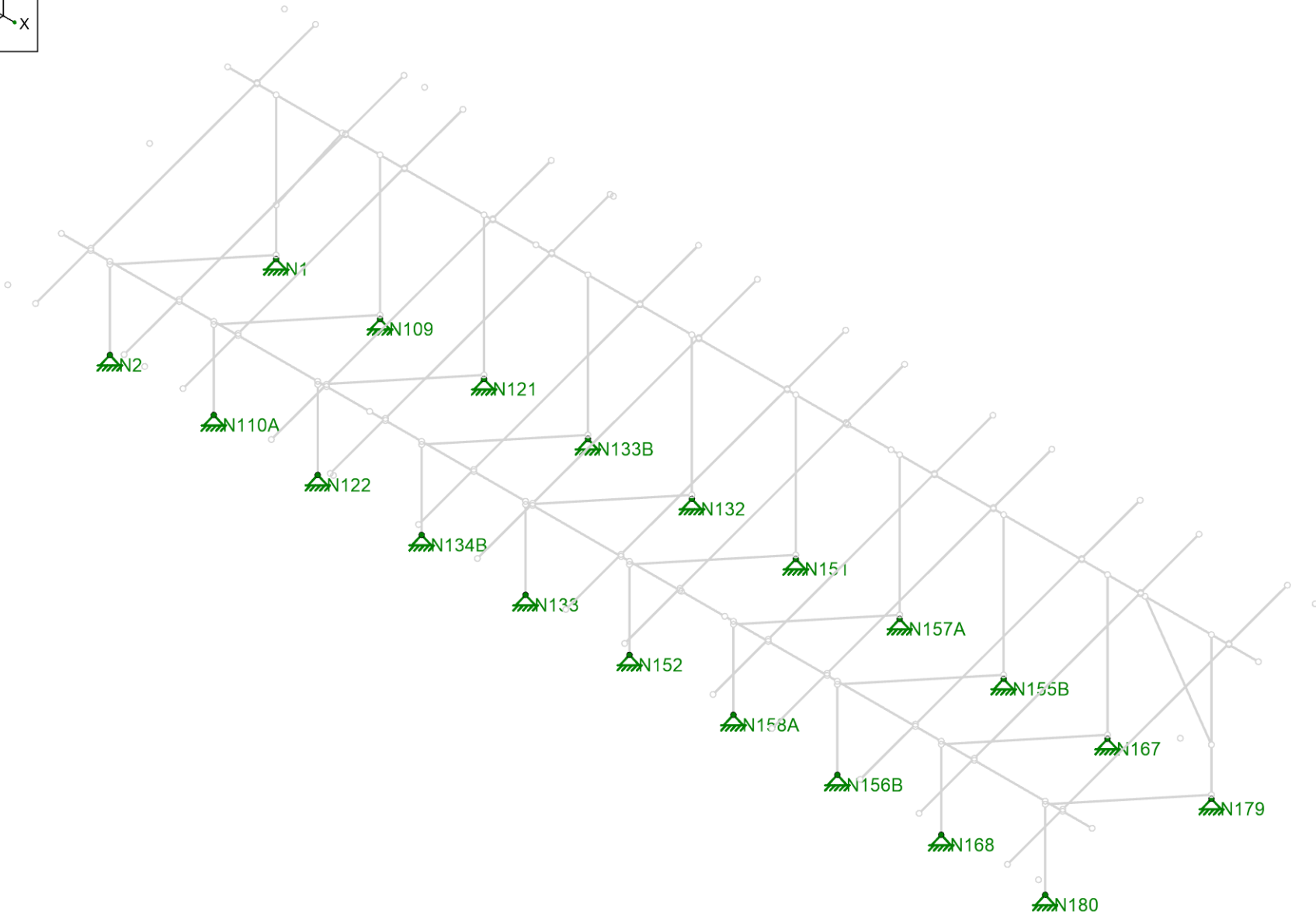
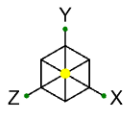

Vector Structural Engineering
STB
U2716.0277.211

Ground Mount

SK-3
Sep 13, 2023 at 04:11 PM
Sunmodo Sunturf D3 GM v2 85x45 - MI...

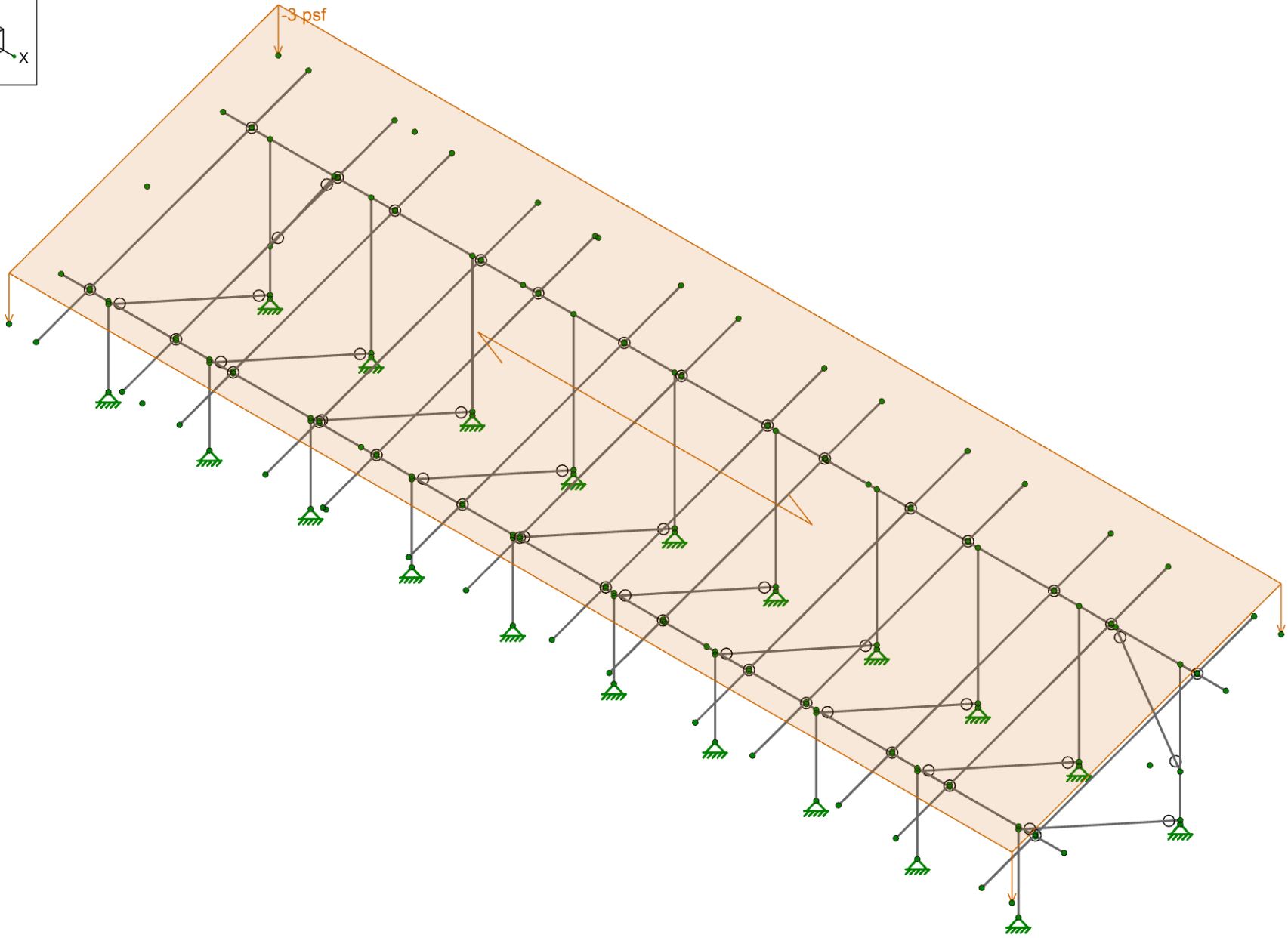
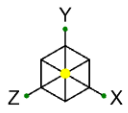

Loads: BLC 2, Solar Panel Weight



Vector Structural Engineering
STB
U2716.0277.211

Ground Mount

SK-4
Sep 13, 2023 at 04:11 PM
Sunmodo Sunturf D3 GM v2 85x45 - MI...

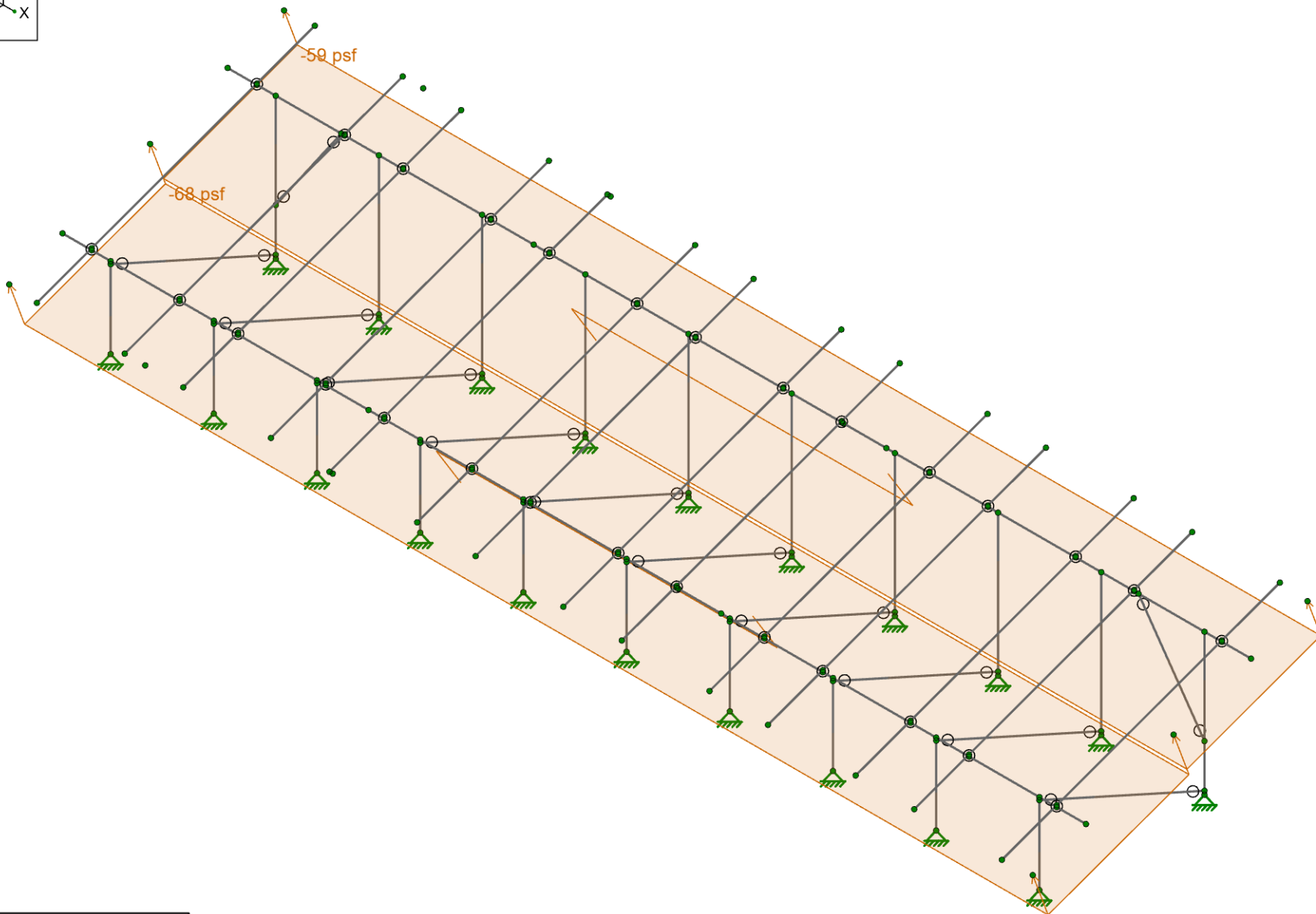
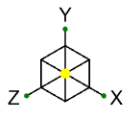

Loads: BLC 4, Wind A 0 deg



Vector Structural Engineering
STB
U2716.0277.211

Ground Mount

SK-5

Sep 13, 2023 at 04:12 PM

Sunmodo Sunturf D3 GM v2 85x45 - MI...

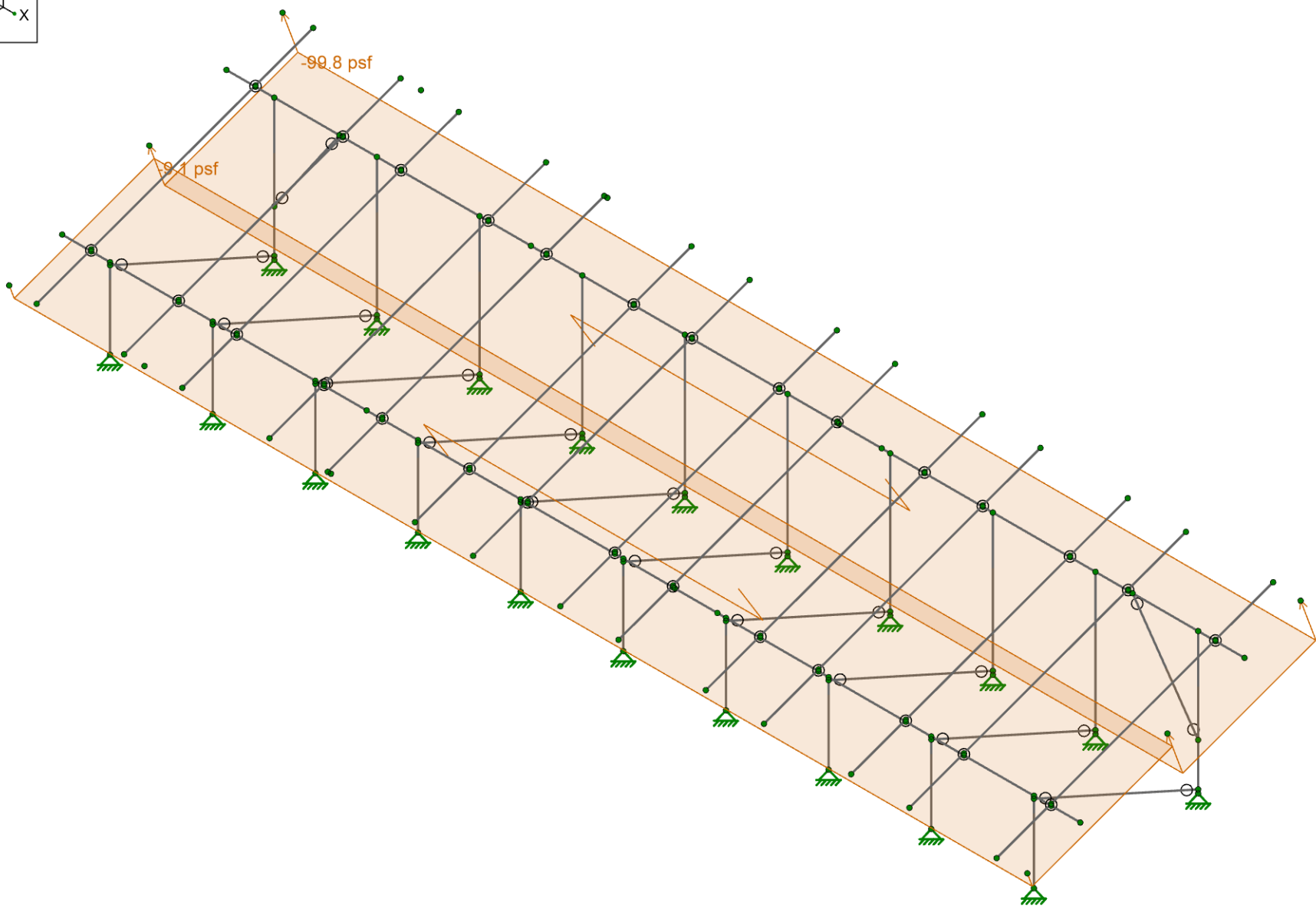
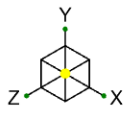

Loads: BLC 5, Wind B 0 deg



Vector Structural Engineering
STB
U2716.0277.211

Ground Mount

SK-6
Sep 13, 2023 at 04:12 PM
Sunmodo Sunturf D3 GM v2 85x45 - MI...

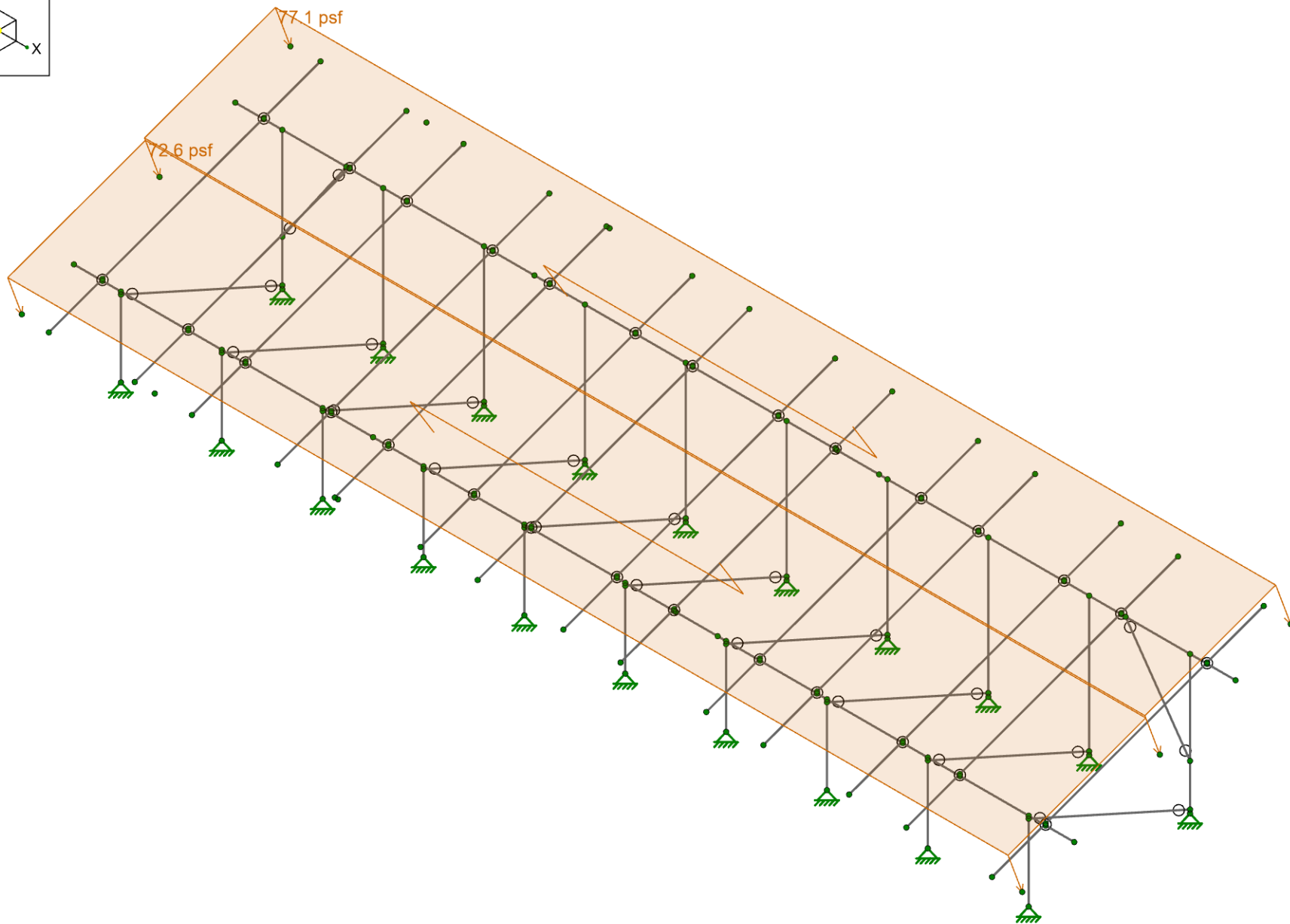
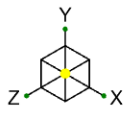

Loads: BLC 6, Wind A 180 deg



Vector Structural Engineering
STB
U2716.0277.211

Ground Mount

SK-7
Sep 13, 2023 at 04:12 PM
Sunmodo Sunturf D3 GM v2 85x45 - MI...

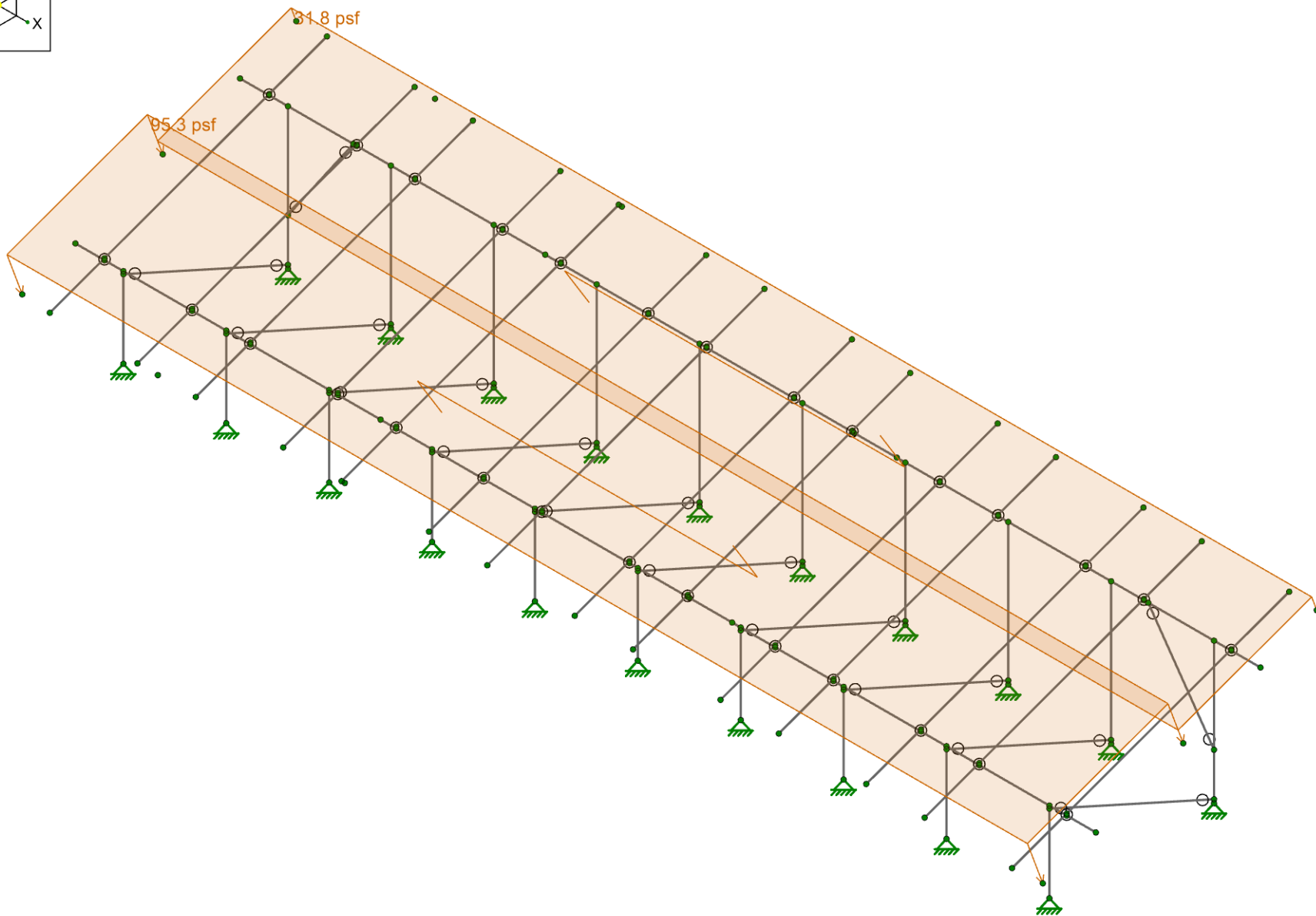
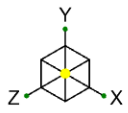

Loads: BLC 7, Wind B 180 deg



Vector Structural Engineering
STB
U2716.0277.211

Ground Mount

SK-8
Sep 13, 2023 at 04:12 PM
Sunmodo Sunturf D3 GM v2 85x45 - MI...

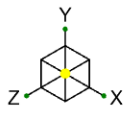

Code Check (Env)

- No Calc
- > 1.0
- .90-.1.0
- .75-.90
- .50-.75
- 0.-.50

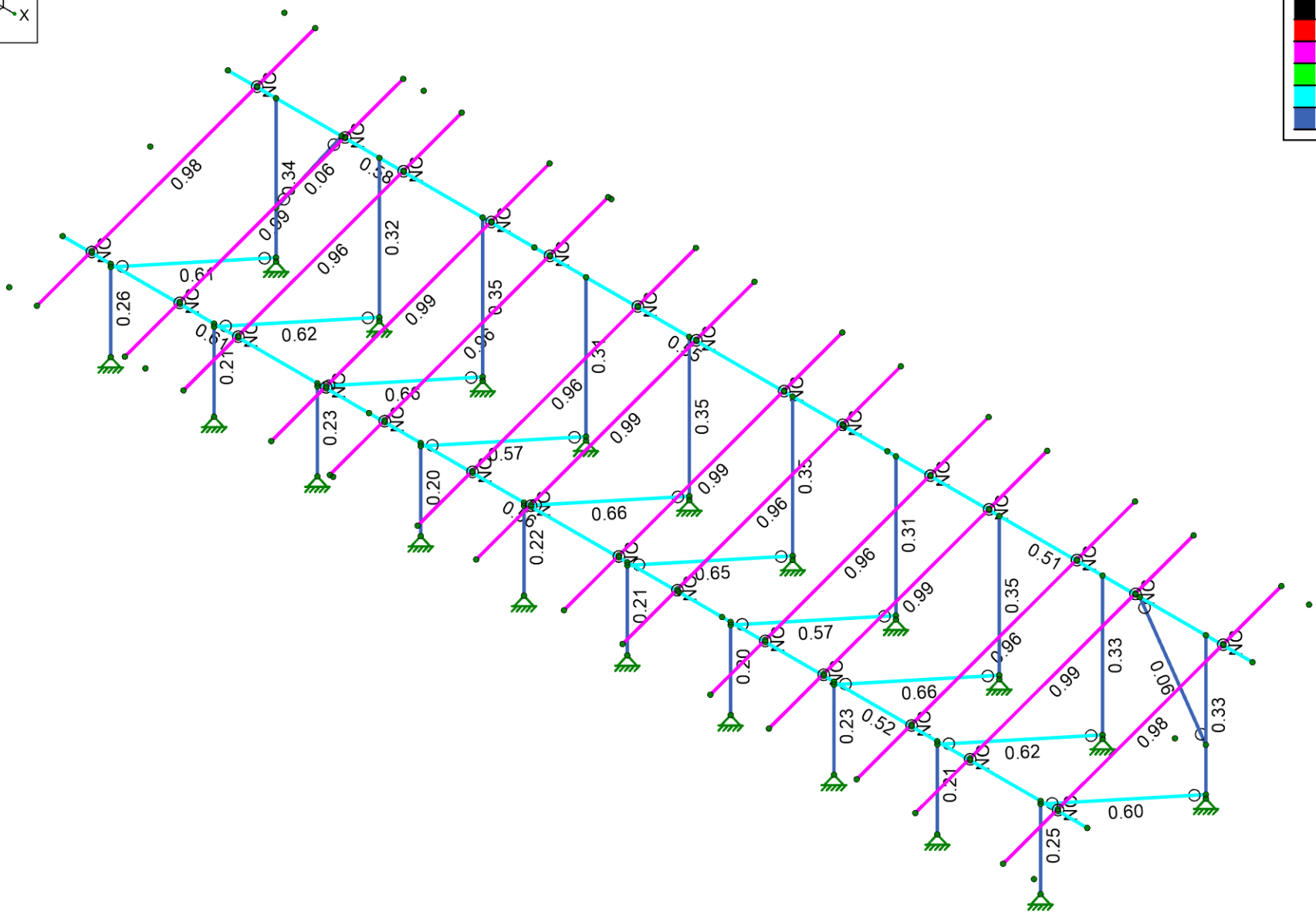

Member Code Checks Displayed (Enveloped)

	Vector Structural Engineering	Ground Mount	SK-9
	STB		Sep 13, 2023 at 04:13 PM
	U2716.0277.211		Sunmodo Sunturf D3 GM v2 85x45 - MI...

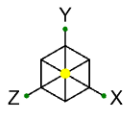

Shear Check (Env)

- No Calc
- > 1.0
- .90-1.0
- .75-.90
- .50-.75
- 0-.50

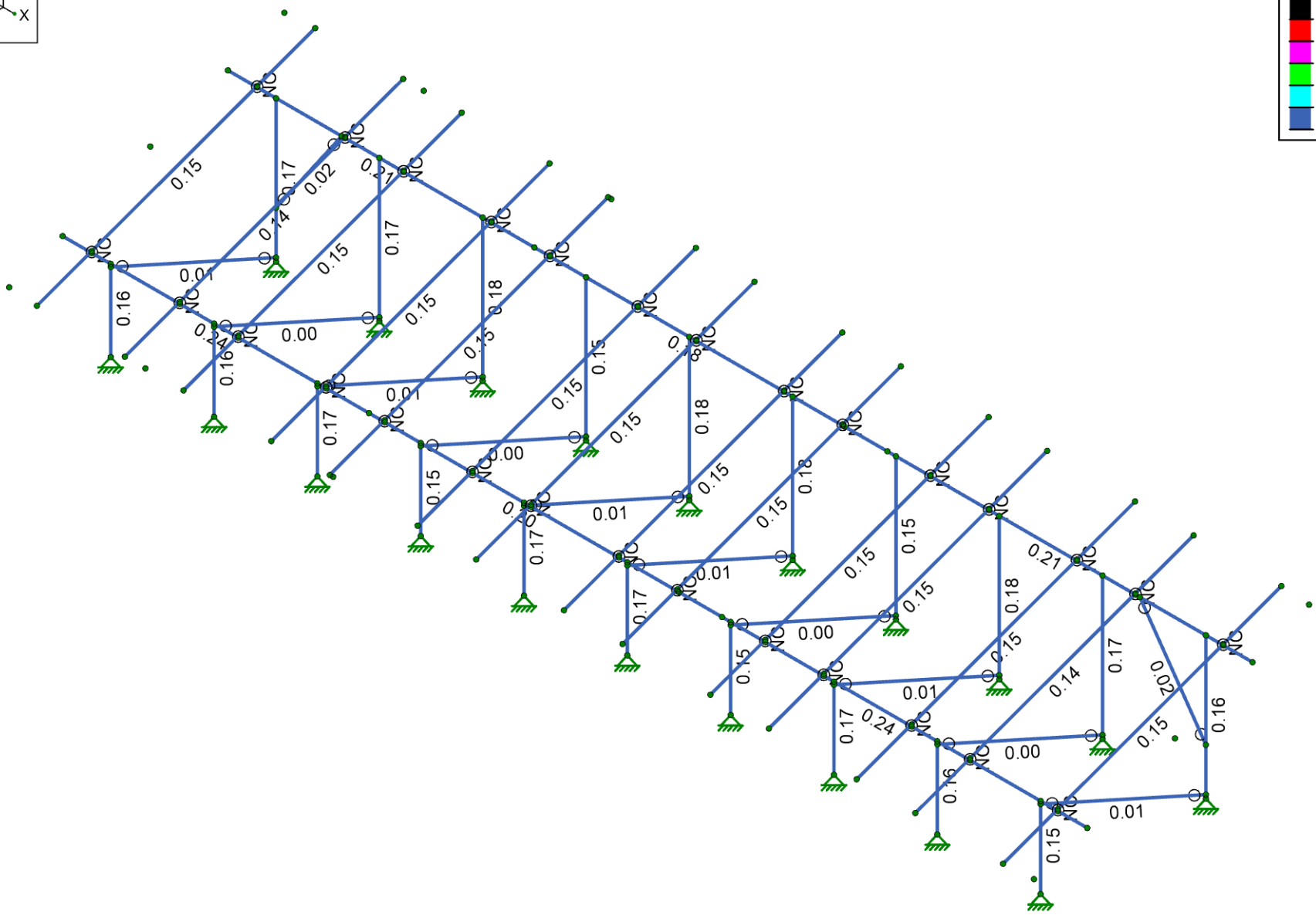

Member Shear Checks Displayed (Enveloped)

 <p>IRISA A NEMETSCHek COMPANY</p>	Vector Structural Engineering	Ground Mount	SK-10
	STB		Sep 13, 2023 at 04:13 PM
	U2716.0277.211		Sunmodo Sunturf D3 GM v2 85x45 - MI...

Model Settings

Number of Reported Sections	5
Number of Internal Sections	100
Member Area Load Mesh Size (in ²)	144
Consider Shear Deformation	Yes
Consider Torsional Warping	Yes
Approximate Mesh Size (in)	24
Transfer Forces Between Intersecting Wood Walls	Yes
Increase Wood Wall Nailing Capacity for Wind Loads	Yes
Include P-Delta for Walls	Yes
Optimize Masonry and Wood Walls	Yes
Maximum Number of Iterations	3
Single	No
Multiple (Optimum)	Yes
Maximum	No

Global Axis corresponding to vertical direction	Y
Convert Existing Data	Yes
Default Global Plane for z-axis	XZ
Plate Local Axis Orientation	Nodal

Hot Rolled Steel	AISC 15th (360-16): ASD
Stiffness Adjustment	Yes (Iterative)
Notional Annex	None
Connections	AISC 15th (360-16): ASD
Cold Formed Steel	AISI S100-16: ASD
Stiffness Adjustment	Yes (Iterative)
Wood	AWC NDS-18 / SDPWS-15 ASD
Temperature	< 100F
Concrete	ACI 318-14
Masonry	None
Aluminum	AA ADM1-15: ASD
Structure Type	Building
Stiffness Adjustment	Yes (Iterative)
Stainless	AISC 14th (360-10): ASD
Stiffness Adjustment	Yes (Iterative)

Analysis Methodology	Exact Integration Method
Parame Beta Factor	0.65

Compression Stress Block	Rectangular Stress Block
Analyze using Cracked Sections	Yes
Leave room for horizontal rebar splices (2*d bar spacing)	Yes
List forces which were ignored for design in the Detail Report	Yes

Column Min Steel	1
Column Max Steel	8
Rebar Material Spec	ASTM A615
Warn if beam-column framing arrangement is not understood	No
Number of Shear Regions	4
Region 2 & 3 Spacing Increase Increment (in)	3.999992

Code	ASCE 7-16
------	-----------

Model Settings (Continued)

Risk Category	I or II
Drift Cat	Other
Base Elevation (ft)	15600
Include the weight of the structure in base shear calcs	Yes
S _i (g)	1
SD _i (g)	1
SD _s (g)	1
T _L (sec)	5
T _Z (sec)	
T _X (sec)	
C _Z	0.02
C _X	0.02
C _{Exp. Z}	0.75
C _{Exp. X}	0.75
R _Z	3
R _X	3
Ω _Z	1
Ω _X	1
C _{aZ}	4
C _{aX}	4
ρ _Z	1
ρ _X	1

Hot Rolled Steel Properties

	Label	E [ksi]	G [ksi]	Nu	Therm. Coeff. [1e ⁵ F ⁻¹]	Density [lb/ft ³]	Yield [psi]	Ry	Fu [psi]	Rt
1	A992	29000	11154	0.3	0.65	490	50000	1.1	65000	1.1
2	A36 Gr.36	29000	11154	0.3	0.65	490	36000	1.5	58000	1.2
3	A572 Gr.50	29000	11154	0.3	0.65	490	50000	1.1	65000	1.1
4	A500 Gr.B RND	29000	11154	0.3	0.65	527	42000	1.4	58000	1.3
5	A500 Gr.B Rect	29000	11154	0.3	0.65	527	46000	1.4	58000	1.3
6	A53 Gr.B	29000	11154	0.3	0.65	490	35000	1.6	60000	1.2
7	A1085	29000	11154	0.3	0.65	490	50000	1.4	65000	1.3

Aluminum Properties

	Label	E [ksi]	G [ksi]	Nu	Therm. Coeff. [1e ⁵ F ⁻¹]	Density [lb/ft ³]	Table B.4	kt	Ftu [psi]	Fty [psi]	Fcy [psi]	Fsu [psi]	Ct
1	3003-H14	10100	3787.5	0.33	1.3	172.8	Table B.4-1	1	19000	16000	13000	12000	141
2	6061-T6	10100	3787.5	0.33	1.3	172.8	Table B.4-2	1	38000	35000	35000	24000	141
3	6063-T5	10100	3787.5	0.33	1.3	172.8	Table B.4-2	1	22000	16000	16000	13000	141
4	6063-T6	10100	3787.5	0.33	1.3	172.8	Table B.4-2	1	30000	25000	25000	19000	141
5	5052-H34	10200	3787.5	0.33	1.3	172.8	Table B.4-1	1	34000	26000	24000	20000	141
6	6061-T6 W	10100	3787.5	0.33	1.3	172.8	Table B.4-1	1	24000	15000	15000	15000	141
7	6005-T5	10100	3787.5	0.33	1.3	172.8	Table B.4-1	1	38000	35000	35000	24000	141

Hot Rolled Steel Section Sets

	Label	Shape	Type	Design List	Material	Design Rule	Area [in ²]	Iyy [in ⁴]	Izz [in ⁴]	J [in ⁴]
1	Post	PIPE2.0A21165	Column	Pipe	A572 Gr.50	Typical	0.776	0.499	0.499	0.998
2	Cross Beam	PIPE2.5A21168	Beam	Wide Flange	A572 Gr.50	Typical	0.947	0.907	0.907	1.814
3	Diagonal Brace	1.5X1.5X0.083	Beam	Tube	A572 Gr.50	Typical	0.47	0.158	0.158	0.236

Aluminum Section Sets

	Label	Shape	Type	Design List	Material	Design Rule	Area [in ²]	Iyy [in ⁴]	Izz [in ⁴]	J [in ⁴]
1	AL Posts	2.375ODX0.188	Column	Pipe	6005-T5	Typical	1.29	0.778	0.778	1.54
2	AL Brace	RT1.5x2x0.15625	VBrace	Rectangular Tubes	6005-T5	Typical	0.996	0.327	0.524	0.602
3	AL Rails	HR300	Beam	Rectangular Tubes	6005-T5	Typical	0.74	0.253	0.727	0.578
4	AL Cross Beam	Cross Rail	Beam	Rectangular Tubes	6005-T5	Typical	1.909	1.97	4.366	4.017

Basic Load Cases

	BLC Description	Category	Y Gravity	Distributed	Area(Member)
1	Self Weight	DL	-1.05		
2	Solar Panel Weight	DL			1
3	Roof Live/Snow	RLL			1
4	Wind A 0 deg	OL1			2
5	Wind B 0 deg	OL2			2
6	Wind A 180 deg	OL3			2
7	Wind B 180 deg	OL4			2
8	BLC 2 Transient Area Loads	None		38	
9	BLC 3 Transient Area Loads	None			
10	BLC 4 Transient Area Loads	None		120	
11	BLC 5 Transient Area Loads	None		120	
12	BLC 6 Transient Area Loads	None		120	
13	BLC 7 Transient Area Loads	None		120	

Load Combinations

	Description	Solve	P-Delta	BLC	Factor	BLC	Factor	BLC	Factor	BLC	BLC	BLC
1	1.0 D	Yes	Y	DL	1							
2	1.0 D + 1.0 S	Yes	Y	DL	1	RLL	1					
3	1.0 D + 0.6 W1	Yes	Y	DL	1	RLL		OL1	0.6			
4	1.0 D + 0.6 W2	Yes	Y	DL	1	RLL		OL2	0.6			
5	1.0 D + 0.6 W3	Yes	Y	DL	1	RLL		OL3	0.6			
6	1.0 D + 0.6 W4	Yes	Y	DL	1	RLL		OL4	0.6			
7	1.0 D + 0.45 W1 + 0.75 S	Yes	Y	DL	1	RLL	0.75	OL1	0.45			
8	1.0 D + 0.45 W2 + 0.75 S	Yes	Y	DL	1	RLL	0.75	OL2	0.45			
9	1.0 D + 0.45 W3 + 0.75 S	Yes	Y	DL	1	RLL	0.75	OL3	0.45			
10	1.0 D + 0.45 W4 + 0.75 S	Yes	Y	DL	1	RLL	0.75	OL4	0.45			
11	0.6 D + 0.6 W1	Yes	Y	DL	0.6	RLL		OL1	0.6			
12	0.6 D + 0.6 W2	Yes	Y	DL	0.6	RLL		OL2	0.6			
13	0.6 D + 0.6 W3	Yes	Y	DL	0.6	RLL		OL3	0.6			
14	0.6 D + 0.6 W4	Yes	Y	DL	0.6	RLL		OL4	0.6			
15												
16	1.4D		Y	DL	1.4					1		
17	1.2D+1.6SL		Y	DL	1.2	RLL	1.6			1	1	
18	1.2D+1.6SL+.5Wx		Y	DL	1.2	RLL	1.6	OL1	0.5	1	1	
19	1.2D+1.6SL-.5Wx		Y	DL	1.2	RLL	1.6	OL2	0.5	1	1	
20	1.2D+1.6SL+.5Wz		Y	DL	1.2	RLL	1.6	OL3	0.5	1	1	
21	1.2D+1.6SL-.5Wz		Y	DL	1.2	RLL	1.6	OL4	0.5	1	1	
22	1.2D+1.0Wx		Y	DL	1.2			OL1	1	1		1
23	1.2D-1.0Wx		Y	DL	1.2			OL2	1	1		1
24	1.2D+1.0Wz		Y	DL	1.2			OL3	1	1		1
25	1.2D-1.0Wz		Y	DL	1.2			OL4	1	1		1
26	.9D+1.0Wx		Y	DL	0.9			OL1	1			1
27	.9D-1.0Wx		Y	DL	0.9			OL2	1			1
28	.9D+1.0Wz		Y	DL	0.9			OL3	1			1
29	.9D-1.0Wz		Y	DL	0.9			OL4	1			1

Envelope Node Reactions

Node Label		X [lb]	LC	Y [lb]	LC	Z [lb]	LC	MX [lb-ft]	LC	MY [lb-ft]	LC	MZ [lb-ft]	LC	
1	N2	max	35.37	11	1289.77	6	51.18	3	0	14	0	14	0	14
2		min	-58.02	6	-571.92	11	-62.56	5	0	1	0	1	0	1
3	N1	max	76.14	5	2524.53	5	1118.43	5	0	14	0	14	0	14
4		min	-88.88	12	-2406.11	12	-949.88	11	0	1	0	1	0	1
5	N132	max	8.79	12	2554.32	5	1207.8	5	0	14	0	14	0	14
6		min	-8.45	5	-2457.56	12	-1022.16	3	0	1	0	1	0	1
7	N133	max	13.7	11	1389.02	6	54.38	3	0	14	0	14	0	14
8		min	-21.48	6	-607.47	11	-66.61	5	0	1	0	1	0	1
9	N109	max	2.52	5	2339	5	1134.95	13	0	14	0	14	0	14
10		min	-2.66	12	-2234.09	12	-963.38	3	0	1	0	1	0	1
11	N110A	max	0.7	5	1420.09	6	52.87	3	0	14	0	14	0	14
12		min	-0.61	12	-649.65	11	-64.86	5	0	1	0	1	0	1
13	N121	max	15.2	5	2556.94	5	1216.76	5	0	14	0	14	0	14
14		min	-15.55	12	-2460.86	12	-1028.79	11	0	1	0	1	0	1
15	N122	max	39.3	6	1349.28	6	54.05	3	0	14	0	14	0	14
16		min	-23.9	11	-578.83	11	-66.21	5	0	1	0	1	0	1
17	N133B	max	5.8	12	2315.64	5	1045.22	5	0	14	0	14	0	14
18		min	-5.54	5	-2200.57	12	-892.49	3	0	1	0	1	0	1
19	N134B	max	7.82	11	1325.38	6	50.24	3	0	14	0	14	0	14
20		min	-12.9	6	-622.73	11	-61.5	5	0	1	0	1	0	1
21	N151	max	7.66	5	2550.34	5	1201.67	5	0	14	0	14	0	14
22		min	-7.84	12	-2453.05	12	-1017.46	3	0	1	0	1	0	1

Envelope Node Reactions (Continued)

Node Label	X [lb]	LC	Y [lb]	LC	Z [lb]	LC	MX [lb-ft]	LC	MY [lb-ft]	LC	MZ [lb-ft]	LC
23 N152 max	20.9	6	1393.75	6	54.23	3	0	14	0	14	0	14
24 min	-13.32	11	-612.62	11	-66.43	5	0	1	0	1	0	1
25 N157A max	6.39	5	2324.94	5	1052.62	5	0	14	0	14	0	14
26 min	-6.57	12	-2210.52	12	-898.33	3	0	1	0	1	0	1
27 N158A max	16.35	6	1325.78	6	50.39	3	0	14	0	14	0	14
28 min	-9.9	11	-620.51	11	-61.69	5	0	1	0	1	0	1
29 N155B max	16.11	12	2544.07	5	1210.21	5	0	14	0	14	0	14
30 min	-15.62	5	-2447.7	12	-1023.38	11	0	1	0	1	0	1
31 N156B max	23.58	11	1344.26	6	53.85	3	0	14	0	14	0	14
32 min	-38.78	6	-577.61	11	-65.97	5	0	1	0	1	0	1
33 N167 max	2.7	12	2366.47	5	1144.64	13	0	14	0	14	0	14
34 min	-2.43	5	-2260.17	12	-971.66	3	0	1	0	1	0	1
35 N168 max	0.98	14	1430.93	6	52.75	3	0	14	0	14	0	14
36 min	-0.54	3	-654.96	11	-64.72	5	0	1	0	1	0	1
37 N179 max	88.28	12	2467.06	5	1093.65	5	0	14	0	14	0	14
38 min	-75.42	5	-2351.11	12	-928.93	11	0	1	0	1	0	1
39 N180 max	52.89	6	1261.34	6	50.62	3	0	14	0	14	0	14
40 min	-32.22	11	-558.3	11	-61.8	5	0	1	0	1	0	1
41 Totals: max	0	5	32720.37	5	10782.97	5						
42 min	0	12	-23340.85	11	-9171.25	11						

Envelope AISC 15TH (360-16): ASD Member Steel Code Checks

Member	Shape	Code Check	Loc[in]	LC	Shear	Check	Loc[in]	Dir	LC	Pnc/om [lb]	Pnt/om [lb]	Mnyy/om [lb-ft]	Mnzz/om [lb-ft]	Cb	Eqn
1 M58A	1.5X1.5X0.083	0.66	54.84	5	0.01	105.29	y	5	2141.68	14085.15	624.42	624.42	1.14	H1-1a	
2 M77A	1.5X1.5X0.083	0.66	54.84	5	0.01	105.29	y	5	2141.68	14085.15	624.42	624.42	1.14	H1-1a	
3 M82	1.5X1.5X0.083	0.66	54.84	5	0.01	105.29	y	5	2141.68	14085.15	624.42	624.42	1.14	H1-1a	
4 M75	1.5X1.5X0.083	0.65	54.84	5	0.01	105.29	y	5	2141.68	14085.15	624.42	624.42	1.14	H1-1a	
5 M83	1.5X1.5X0.083	0.62	54.84	5	0	105.29	y	4	2141.68	14085.15	624.42	624.42	1.14	H1-1a	
6 M52	1.5X1.5X0.083	0.62	54.84	5	0	105.29	y	4	2141.68	14085.15	624.42	624.42	1.14	H1-1a	
7 M15	1.5X1.5X0.083	0.61	54.84	5	0.01	105.29	y	4	2141.68	14085.15	624.42	624.42	1.14	H1-1a	
8 M13	PIPE2.5A21168	0.61	27.81	6	0.24	148.33	y	6	11641.04	28358.41	2081.75	2081.75	1	H1-1b	
9 M95	1.5X1.5X0.083	0.6	54.84	5	0.01	105.29	y	4	2141.68	14085.15	624.42	624.42	1.14	H1-1a	
10 M14	PIPE2.5A21168	0.58	27.81	12	0.21	152.04	y	12	11641.04	28358.41	2081.75	2081.75	1	H1-1b	
11 M78	1.5X1.5X0.083	0.57	54.84	5	0	105.29	y	6	2141.68	14085.15	624.42	624.42	1.14	H1-1a	
12 M70	1.5X1.5X0.083	0.57	54.84	5	0	105.29	y	6	2141.68	14085.15	624.42	624.42	1.14	H1-1a	
13 M68A	PIPE2.5A21168	0.56	30	6	0.2	90	y	6	11641.04	28358.41	2081.75	2081.75	1	H1-1b	
14 M70A	PIPE2.5A21168	0.55	30	12	0.18	90	y	12	11641.04	28358.41	2081.75	2081.75	1	H1-1b	
15 M69A	PIPE2.5A21168	0.52	29.64	6	0.24	88.91	y	6	11641.04	28358.41	2081.75	2081.75	1	H1-1b	
16 M71	PIPE2.5A21168	0.51	29.64	12	0.21	86.44	y	12	11641.04	28358.41	2081.75	2081.75	1	H1-1b	
17 M57A	PIPE2.0A21165	0.35	1.71	5	0.18	1.71	y	5	10794.34	23232.19	1397.5	1397.5	1	H1-1a	
18 M81	PIPE2.0A21165	0.35	1.71	5	0.18	1.71	y	5	10794.34	23232.19	1397.5	1397.5	1	H1-1a	
19 M76A	PIPE2.0A21165	0.35	1.71	5	0.18	1.71	y	5	10794.34	23232.19	1397.5	1397.5	1	H1-1a	
20 M74	PIPE2.0A21165	0.35	1.71	5	0.18	1.71	y	5	10794.34	23232.19	1397.5	1397.5	1	H1-1a	
21 M6	PIPE2.0A21165	0.34	1.71	5	0.17	1.71	y	5	10794.34	23232.19	1397.5	1397.5	1	H1-1a	
22 M94	PIPE2.0A21165	0.33	1.71	5	0.16	1.71	y	5	10794.34	23232.19	1397.5	1397.5	1	H1-1a	
23 M82A	PIPE2.0A21165	0.33	1.71	5	0.17	1.71	y	5	10794.34	23232.19	1397.5	1397.5	1	H1-1a	
24 M51	PIPE2.0A21165	0.32	1.71	5	0.17	1.71	y	5	10794.34	23232.19	1397.5	1397.5	1	H1-1a	
25 M77	PIPE2.0A21165	0.31	1.71	5	0.15	1.71	y	5	10794.34	23232.19	1397.5	1397.5	1	H1-1a	
26 M69	PIPE2.0A21165	0.31	1.71	5	0.15	1.71	y	5	10794.34	23232.19	1397.5	1397.5	1	H1-1a	
27 M5	PIPE2.0A21165	0.26	45.34	6	0.16	46.8	y	5	18111.85	23232.19	1397.5	1397.5	1	H1-1b	
28 M93	PIPE2.0A21165	0.25	45.34	6	0.15	46.8	y	5	18111.85	23232.19	1397.5	1397.5	1	H1-1b	
29 M56A	PIPE2.0A21165	0.23	45.34	6	0.17	46.8	y	5	18111.85	23232.19	1397.5	1397.5	1	H1-1b	
30 M75B	PIPE2.0A21165	0.23	45.34	6	0.17	46.8	y	5	18111.85	23232.19	1397.5	1397.5	1	H1-1b	
31 M80	PIPE2.0A21165	0.22	45.34	5	0.17	46.8	y	5	18111.85	23232.19	1397.5	1397.5	1	H1-1b	
32 M73	PIPE2.0A21165	0.21	45.34	5	0.17	46.8	y	5	18111.85	23232.19	1397.5	1397.5	1	H1-1b	

Envelope AISC 15TH (360-16): ASD Member Steel Code Checks (Continued)

Member	Shape	Code	Check	Loc[in]	LC	Shear	Check	Loc[in]	Dir	LC	Pnc/om [lb]	Pnt/om [lb]	Mnyy/om [lb-ft]	Mnzz/om [lb-ft]	Cb	Eqn
33	M50	PIPE2.0A21165	0.21	45.34	5	0.16	46.8		5	18111.85	23232.19	1397.5	1397.5	1	H1-1b	
34	M81A	PIPE2.0A21165	0.21	45.34	5	0.16	46.8		5	18111.85	23232.19	1397.5	1397.5	1	H1-1b	
35	M76	PIPE2.0A21165	0.2	45.34	5	0.15	46.8		5	18111.85	23232.19	1397.5	1397.5	1	H1-1b	
36	M68	PIPE2.0A21165	0.2	45.34	5	0.15	46.8		5	18111.85	23232.19	1397.5	1397.5	1	H1-1b	
37	M19	1.5X1.5X0.083	0.06	66.99	5	0.02	66.99	y	5	5291.39	14085.15	624.42	624.42	1.14	H1-1b*	
38	M75A	1.5X1.5X0.083	0.06	67.13	5	0.02	67.13	y	5	5268.94	14085.15	624.42	624.42	1.14	H1-1b*	

Envelope AA ADM1-15: ASD - BUILDING Member Aluminum Code Checks

Member	Shape	Code	Check	Loc[in]	LC	Shear	Check	Loc[in]	Dir	LC	Pnc/om [lb]	Pnt/om [lb]	Mny/om [lb-ft]	Mnz/om [lb-ft]	Vny/om [lb]	Vnz/om [lb]	Cb	Eqn
1	M50A	HR300	0.99	134.37	12	0.15	34.04	y	6	3575.14	14429.59	560.36	934.13	5656.69	2605.14	1.98	H.1-1	
2	M59	HR300	0.99	134.37	12	0.15	34.04	y	6	3575.14	14429.59	560.36	934.13	5656.69	2605.14	1.98	H.1-1	
3	M62	HR300	0.99	134.37	12	0.15	34.04	y	6	3575.14	14429.59	560.36	934.13	5656.69	2605.14	1.98	H.1-1	
4	M44	HR300	0.99	34.04	6	0.14	34.04	y	6	3575.14	14429.59	560.36	934.13	5656.69	2605.14	1.52	H.1-1	
5	M71A	HR300	0.99	134.37	12	0.15	34.04	y	6	3575.14	14429.59	560.36	934.13	5656.69	2605.14	1.98	H.1-1	
6	M77B	HR300	0.99	34.04	6	0.14	34.04	y	6	3575.14	14429.59	560.36	934.13	5656.69	2605.14	1.52	H.1-1	
7	M80A	HR300	0.98	134.37	12	0.15	34.04	y	6	3575.14	14429.59	560.36	934.13	5656.69	2605.14	2.09	H.1-1	
8	M16	HR300	0.98	134.37	12	0.15	34.04	y	6	3575.14	14429.59	560.36	934.13	5656.69	2605.14	2.09	H.1-1	
9	M74A	HR300	0.96	134.37	12	0.15	34.04	y	6	3575.14	14429.59	560.36	934.13	5656.69	2605.14	1.98	H.1-1	
10	M47	HR300	0.96	134.37	12	0.15	34.04	y	6	3575.14	14429.59	560.36	934.13	5656.69	2605.14	1.98	H.1-1	
11	M65	HR300	0.96	134.37	12	0.15	34.04	y	6	3575.14	14429.59	560.36	934.13	5656.69	2605.14	1.98	H.1-1	
12	M56	HR300	0.96	134.37	12	0.15	34.04	y	6	3575.14	14429.59	560.36	934.13	5656.69	2605.14	1.98	H.1-1	
13	M68B	HR300	0.96	134.37	12	0.15	34.04	y	6	3575.14	14429.59	560.36	934.13	5656.69	2605.14	1.98	H.1-1	
14	M53	HR300	0.96	134.37	12	0.15	34.04	y	6	3575.14	14429.59	560.36	934.13	5656.69	2605.14	1.98	H.1-1	

NOTES: UNLESS OTHERWISE SPECIFIED
 1. DIMENSIONS SHOWN ARE INCHES [MILIMETERS].

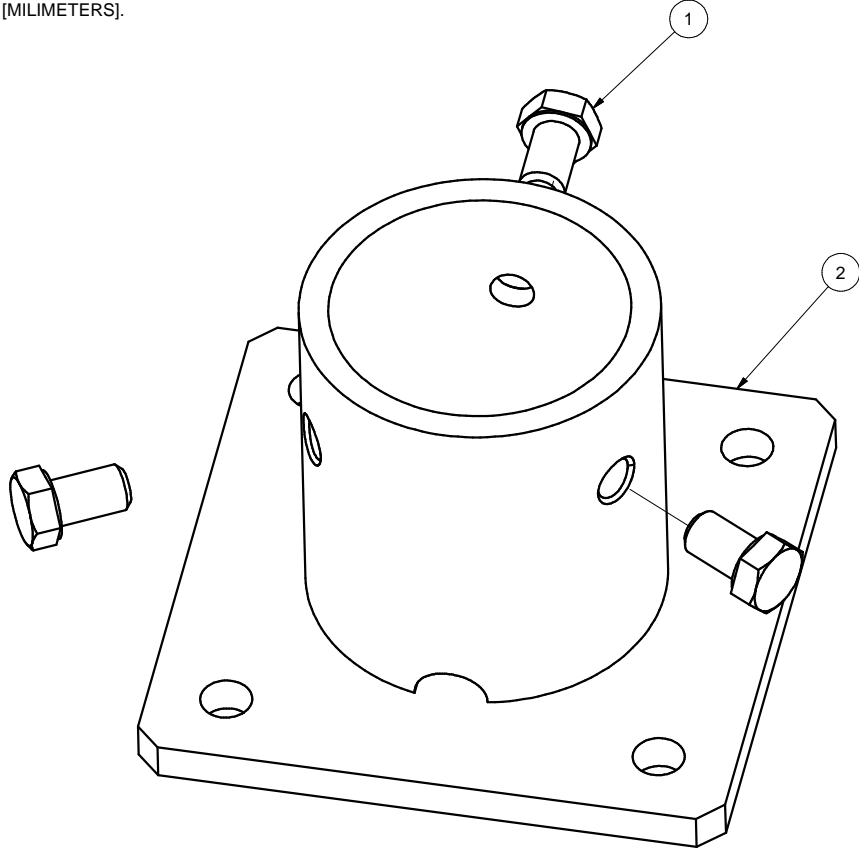

REVISIONS			
REV	DESCRIPTION	BY	DATE
A	INITIAL RELEASE	LWF	10/20/2016

2	A21120-001	2" PIPE BASE	1
1	B15018-011	HEX CAP SCREW 3/8-16 X 5/8	3
ITEM	PART NUMBER	DESCRIPTION	QTY
MATERIAL		SEE NOTES	
Third Angle Projection:			
GENERAL SPECIFICATIONS		Sunmodo Corp. 1905 E 5TH STREET, STE A, VANCOUVER, WA 98661	
Tolerances		TITLE	
X.XXX ±0.01 [0.25mm] X.XX ±0.02 [0.50mm] X.X ±0.039 [1.0mm] Unless otherwise spec'd		2" PIPE BASE KIT	
DRAWN BY	DATE	DRAWING NUMBER	
LWF	10/20/2016	B K10268-001	
CHECKED BY			
APPROVALS		SCALE: NONE	SHEET 1 of 1

THIS DRAWING IS CONFIDENTIAL PROPERTY OF SUNMODO AND ITS CONTENTS MAY NOT BE DISCLOSED WITHOUT THE PRIOR WRITTEN CONSENT OF SUNMODO CORP.

NOTES: UNLESS OTHERWISE SPECIFIED

1. DIMENSIONS SHOWN ARE INCHES [MILIMETERS].
2. MATERAIL: ALUMINUM 6005-T5.
FINISH: CLEAR ANODIZED 10 μ m THICK.
3. THE UNSPECIFIED DIMENSIONS ARE SPECIFIED BY 2D CAD FILE.

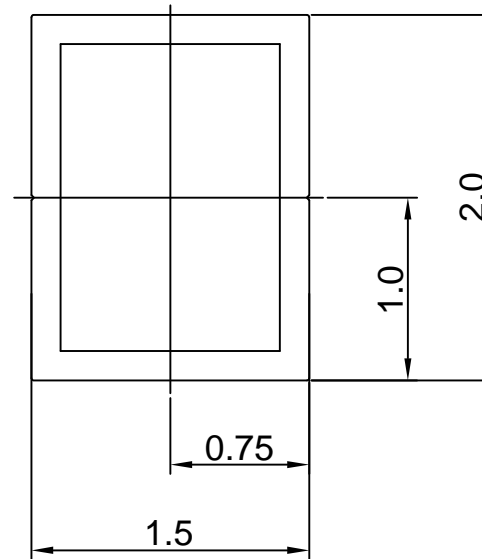

Section properties:

Weight: 1.156 lbs/ft

Area: 0.992 in²

Perimeter: 12.601 in

Bounding Box: X: -1.000,1.000

Y: -0.750, 0.750

Centroid:(0.000,0.000)

Moments of Inertia(in⁴): I_x=0.506,I_y=0.322

Section modulus in bending(in³): W_x=0.675,W_y=0.322

Radii of Gyration: X: 0.714, Y: 0.570

MATERIAL		SEE NOTES	
Third Angle Projection:			
GENERAL SPECIFICATIONS			
All Dimensions in inches [millimeters]			
Tolerances			
X.XXX ± 0.01 [0.25mm]	Break all sharp edges		
X.XX ± 0.02 [0.50mm]	.010-.020 unless		
X.X ± 0.039 [1.0mm]	otherwise specified.		
DRAWN BY		DATE	
zcg		03/12/2014	
CHECKED BY			
APPROVALS			
		1905 E 5TH STREET, SUITE A, VANCOUVER, WA 98661	
		TITLE	
		1.5X2 AL TUBE BRACE EXTRUSION	
		DRAWING NUMBER	
		A20164	
		SCALE: NONE	
		SHEET 1 of 1	

REVISIONS			
REV	DESCRIPTION	BY	DATE
A	ADDED BOTTOM CHANNEL & CHANGED ONE 3/8 CHANNEL TO 1/4	zcg	02/21/2013

NOTES: UNLESS OTHERWISE SPECIFIED

1. DIMENSIONS SHOWN ARE INCHES [MILIMETERS].
2. MATERAIL: ALUMINUM 6005-T5.
FINISH: CLEAR ANODIZED 15 μ m THICK.
3. THE UNSPECIFIED DIMENSIONS ARE SPECIFIED BY 2D CAD FILE.

2X 1/4 BOLT SLOT

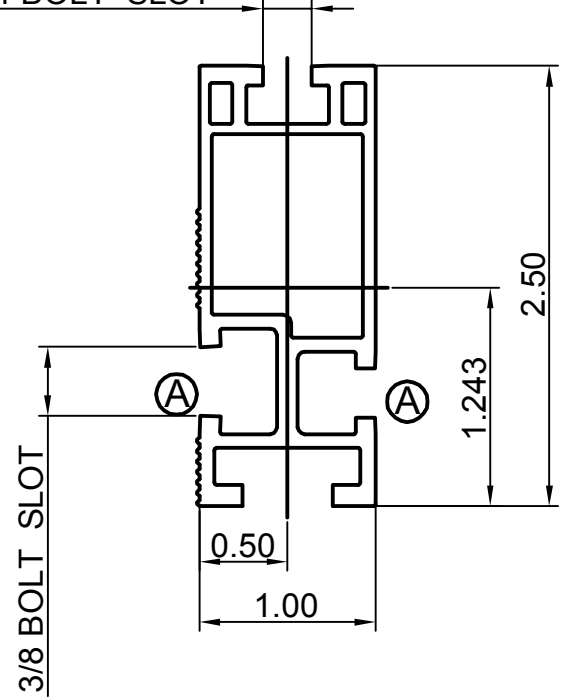

Section properties:

Weight: 0.850 lbs/ft
 Area: 0.723 in²
 Perimeter: 17.325 in
 Bounding Box: X: -0.500,0.500
 Y: -1.243,1.257

Centroid:(0.000,0.000)
 Moments of Inertia(in⁴): I_x=0.486,I_y=0.095
 Section modulus in bending(in³): W_x=0.387,W_y=0.190
 Radii of Gyration: X: 0.820, Y: 0.363

MATERIAL SEE NOTES		Sunmodo Corp.	
Third Angle Projection:			
GENERAL SPECIFICATIONS All Dimensions in inches [millimeters]		1905 E 5TH STREET, SUITE A, VANCOUVER, WA 98661	
Tolerances: X.XXX ± 0.01 [0.25mm] X.XX ± 0.02 [0.50mm] X.X ± 0.039 [1.0mm] Unless otherwise spec'd		TITLE HELIO STANDARD RAIL	
DRAWN BY zcg	DATE 02/21/2013	DRAWING NUMBER A20144	
CHECKED BY		SCALE: NONE SHEET 1 of 1	
APPROVALS			

NOTES: UNLESS OTHERWISE SPECIFIED

1. DIMENSIONS SHOWN ARE INCHES [MILIMETERS].
2. MATERIAL: 6005-T5.
FINISH: CLEAR ANODIZED 10um THICK.
3. THE UNSPECIFIED RADII ARE .02" MAX.
4. THE UNSPECIFIED DIMENSIONS ARE SPECIFIED BY 2D CAD FILE.

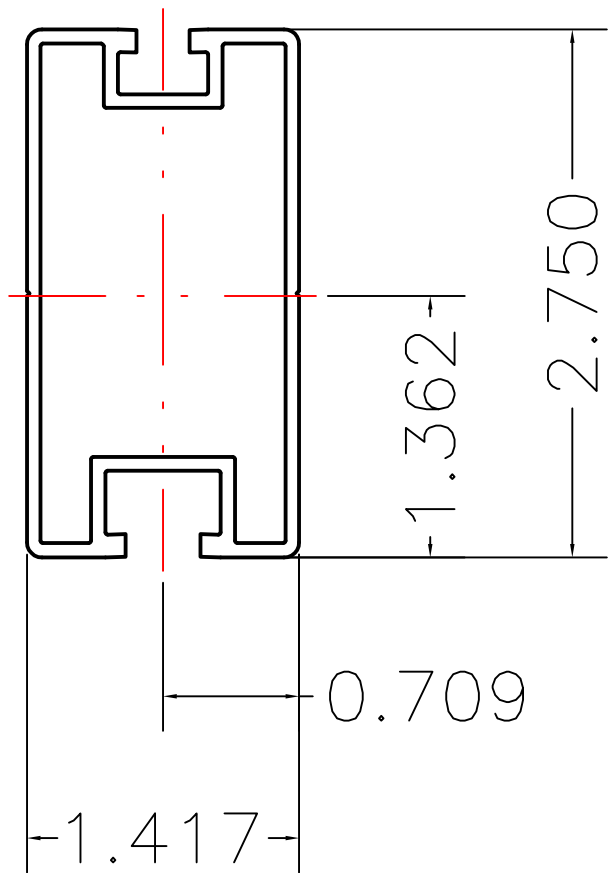

Section properties:

Weight: 0.862 lbs/ft
 Area: 0.736 in²
 Perimeter: 19.824 in
 Bounding Box: X: -0.709,0.709
 Y: -1.362,1.388
 Centroid:(0.000,0.000)
 Moments of Inertia(in⁴): I_x=0.727,I_y=0.214
 Section modulus in bending(in³): W_x=0.524,W_y=0.302
 Radii of Gyration: X: 994, Y: 0.539

MATERIAL SEE NOTES	
Third Angle Projection:	
GENERAL SPECIFICATIONS All Dimensions in inches [millimeters]	
Tolerances	
X.XXX ±0.01 [0.25mm]	Break all sharp edges
X.XX ±0.02 [0.50mm]	.010-.020 unless
X.X ±0.039 [1.0mm]	otherwise specified.
Unless otherwise spec'd	
DRAWN BY KYY	DATE 01/18/2018
CHECKED BY	
APPROVALS	

SunModo Corp.	
14800 NE 65TH STREET, VANCOUVER WA 98682	
TITLE RAIL, HR300 (SUNRAY), EXTRUSION	
B	DRAWING NUMBER A20288
SCALE: NONE	SHEET 1 of 1

THIS DRAWING IS CONFIDENTIAL PROPERTY OF SUNMODO AND ITS CONTENTS MAY NOT BE DISCLOSED WITHOUT THE PRIOR WRITTEN CONSENT OF SUNMODO CORP.

REV	DESCRIPTON	BY	DATE
A	0.44 WAS 0.41, 0.44 WAS 0.33	LWF	11/30/2015

NOTES: UNLESS OTHERWISE SPECIFIED

1. DIMENSIONS SHOWN ARE INCHES [MILIMETERS].
2. MATERIAL: ALUMINUM 6005-T5.
FINISH: CLEAR ANODIZED 15 μm THICK.
3. THE UNSPECIFIED DIMENSIONS ARE SPECIFIED BY 2D CAD FILE.

2X 1/4 BOLT SLOT

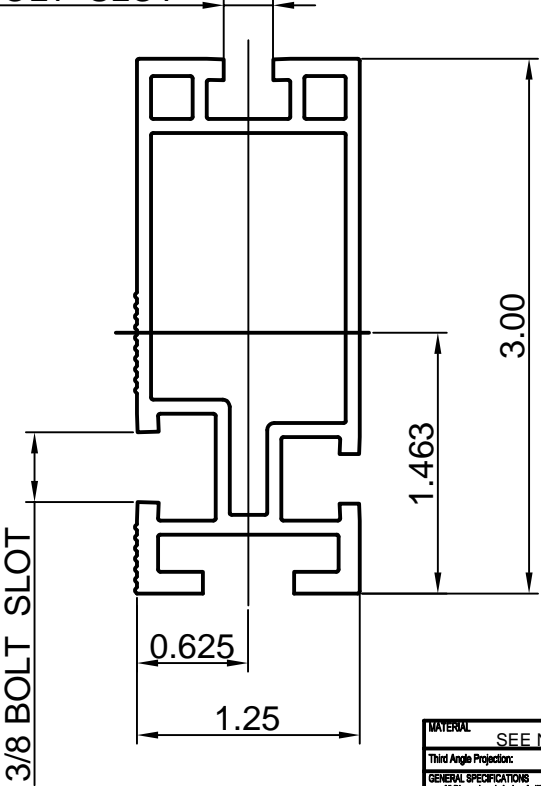

Section properties:

Weight: 1.151 lbs/ft
 Area: 0.980 in²
 Perimeter: 22.104 in
 Bounding Box: X: -0.625,0.625
 Y: -1.463,1.537
 Centroid:(0.000,0.000)
 Moments of Inertia(in⁴): Ix=1.047,Iy=0.207
 Section modulus in bending(in³): Wx=0.681,Wy=0.331
 Radii of Gyration: X: 1.034, Y: 0.460

MATERIAL		SEE NOTES	
Third Angle Projection			
GENERAL SPECIFICATIONS			
All Dimensions in Inches (millimeters)			
Tolerances			
XXX ±0.01 (0.25mm)			
XX ±0.02 (0.50mm)			
X ±0.03 (1.0mm)			
Unless otherwise specified.			
DRAWN BY		DATE	
ZCG		02/21/2013	
CHECKED BY		DATE	
APPROVALS		DATE	
Sunmodo Corp.		1905 E 5TH STREET, SUITE A, VANCOUVER, WA 98661	
		TITLE	
HELIO HEAVY RAIL		DRAWING NUMBER	
		A20145	
SCALE: NONE		SHEET 1 of 1	

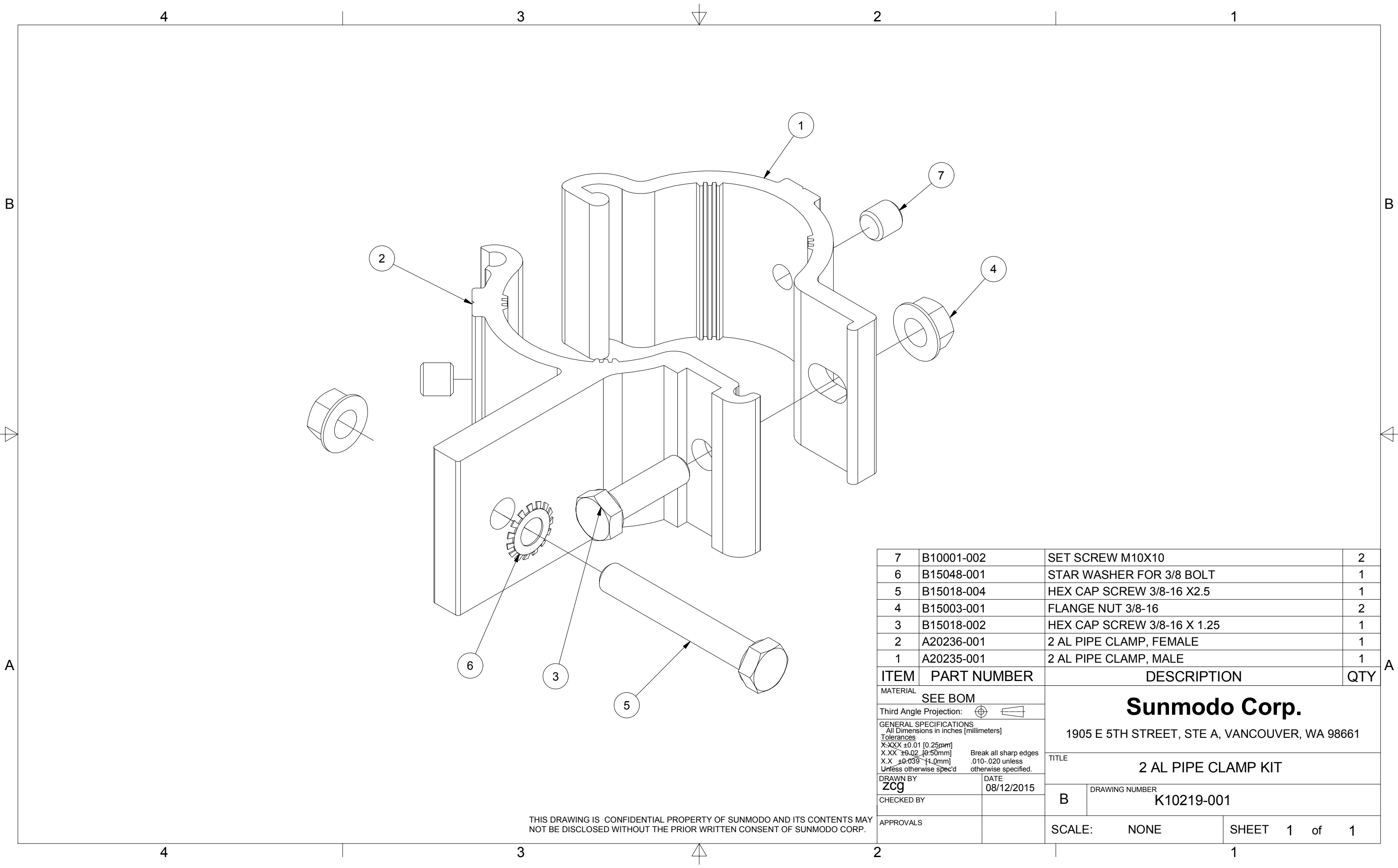

7	B10001-002	SET SCREW M10X10	2
6	B15048-001	STAR WASHER FOR 3/8 BOLT	1
5	B15018-004	HEX CAP SCREW 3/8-16 X2.5	1
4	B15003-001	FLANGE NUT 3/8-16	2
3	B15018-002	HEX CAP SCREW 3/8-16 X 1.25	1
2	A20236-001	2 AL PIPE CLAMP, FEMALE	1
1	A20235-001	2 AL PIPE CLAMP, MALE	1

ITEM	PART NUMBER	DESCRIPTION	QTY
MATERIAL		SEE BOM	
Third Angle Projection:			
GENERAL SPECIFICATIONS All Dimensions in inches (millimeters)			
Tolerances			
X.XXX ±0.01 [0.25mm]			
X.XX ±0.02 [0.50mm]			
X.X ±0.039 [1.0mm]			
Unless otherwise spec'd			
DRAWN BY		DATE	
zcg		08/12/2015	
CHECKED BY		TITLE	
		2 AL PIPE CLAMP KIT	
APPROVALS		DRAWING NUMBER	
		B K10219-001	
SCALE:		NONE	SHEET 1 of 1

THIS DRAWING IS CONFIDENTIAL PROPERTY OF SUNMODO AND ITS CONTENTS MAY NOT BE DISCLOSED WITHOUT THE PRIOR WRITTEN CONSENT OF SUNMODO CORP.

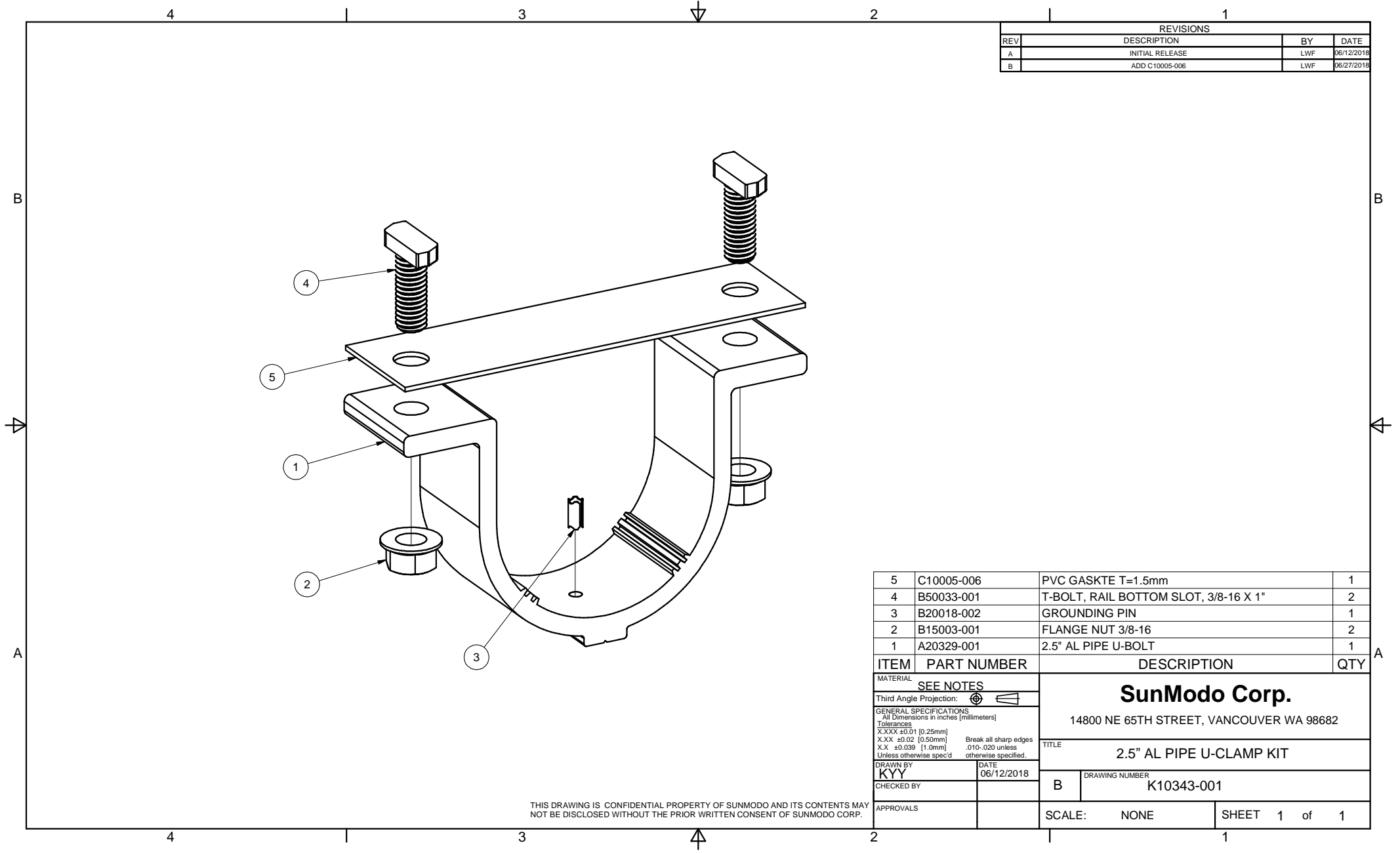

REVISIONS			
REV	DESCRIPTION	BY	DATE
A	INITIAL RELEASE	LWF	06/12/2018
B	ADD C10005-006	LWF	06/27/2018

ITEM	PART NUMBER	DESCRIPTION	QTY
5	C10005-006	PVC GASKTE T=1.5mm	1
4	B50033-001	T-BOLT, RAIL BOTTOM SLOT, 3/8-16 X 1"	2
3	B20018-002	GROUNDING PIN	1
2	B15003-001	FLANGE NUT 3/8-16	2
1	A20329-001	2.5" AL PIPE U-BOLT	1

MATERIAL		SEE NOTES	
Third Angle Projection:			
GENERAL SPECIFICATIONS		SunModo Corp. 14800 NE 65TH STREET, VANCOUVER WA 98682	
Tolerances		TITLE	
X.XXX ±0.01 [0.25mm] X.XX ±0.02 [0.50mm] X.X ±0.039 [1.0mm] Unless otherwise spec'd		2.5" AL PIPE U-CLAMP KIT	
DRAWN BY	DATE	DRAWING NUMBER	
KYY	06/12/2018	B K10343-001	
CHECKED BY		SCALE: NONE SHEET 1 of 1	
APPROVALS			

THIS DRAWING IS CONFIDENTIAL PROPERTY OF SUNMODO AND ITS CONTENTS MAY NOT BE DISCLOSED WITHOUT THE PRIOR WRITTEN CONSENT OF SUNMODO CORP.

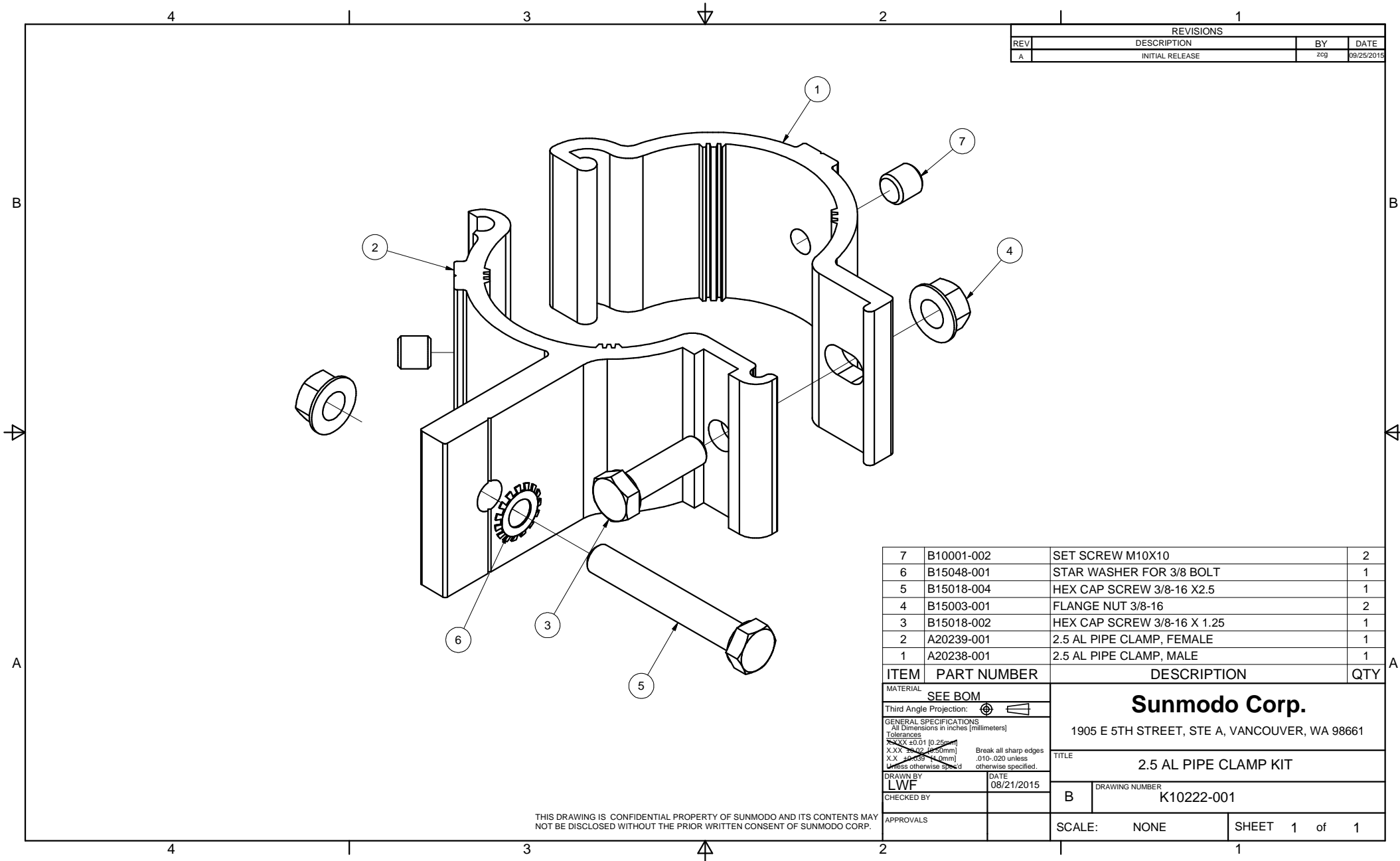

REVISIONS			
REV	DESCRIPTION	BY	DATE
A	INITIAL RELEASE	zcg	09/25/2015

ITEM	PART NUMBER	DESCRIPTION	QTY
7	B10001-002	SET SCREW M10X10	2
6	B15048-001	STAR WASHER FOR 3/8 BOLT	1
5	B15018-004	HEX CAP SCREW 3/8-16 X2.5	1
4	B15003-001	FLANGE NUT 3/8-16	2
3	B15018-002	HEX CAP SCREW 3/8-16 X 1.25	1
2	A20239-001	2.5 AL PIPE CLAMP, FEMALE	1
1	A20238-001	2.5 AL PIPE CLAMP, MALE	1

MATERIAL		SEE BOM	
Third Angle Projection:			
GENERAL SPECIFICATIONS All Dimensions in inches [millimeters] Tolerances X.XX ±0.01 (0.25mm) X.X ±0.02 (0.5mm) X.X ±0.03 (0.75mm) Unless otherwise specified.			
DRAWN BY		DATE	
LWF		08/21/2015	
CHECKED BY		B	
APPROVALS		SCALE: NONE	
		SHEET 1 of 1	

Sunmodo Corp.
 1905 E 5TH STREET, STE A, VANCOUVER, WA 98661

TITLE
2.5 AL PIPE CLAMP KIT

DRAWING NUMBER
K10222-001

THIS DRAWING IS CONFIDENTIAL PROPERTY OF SUNMODO AND ITS CONTENTS MAY NOT BE DISCLOSED WITHOUT THE PRIOR WRITTEN CONSENT OF SUNMODO CORP.

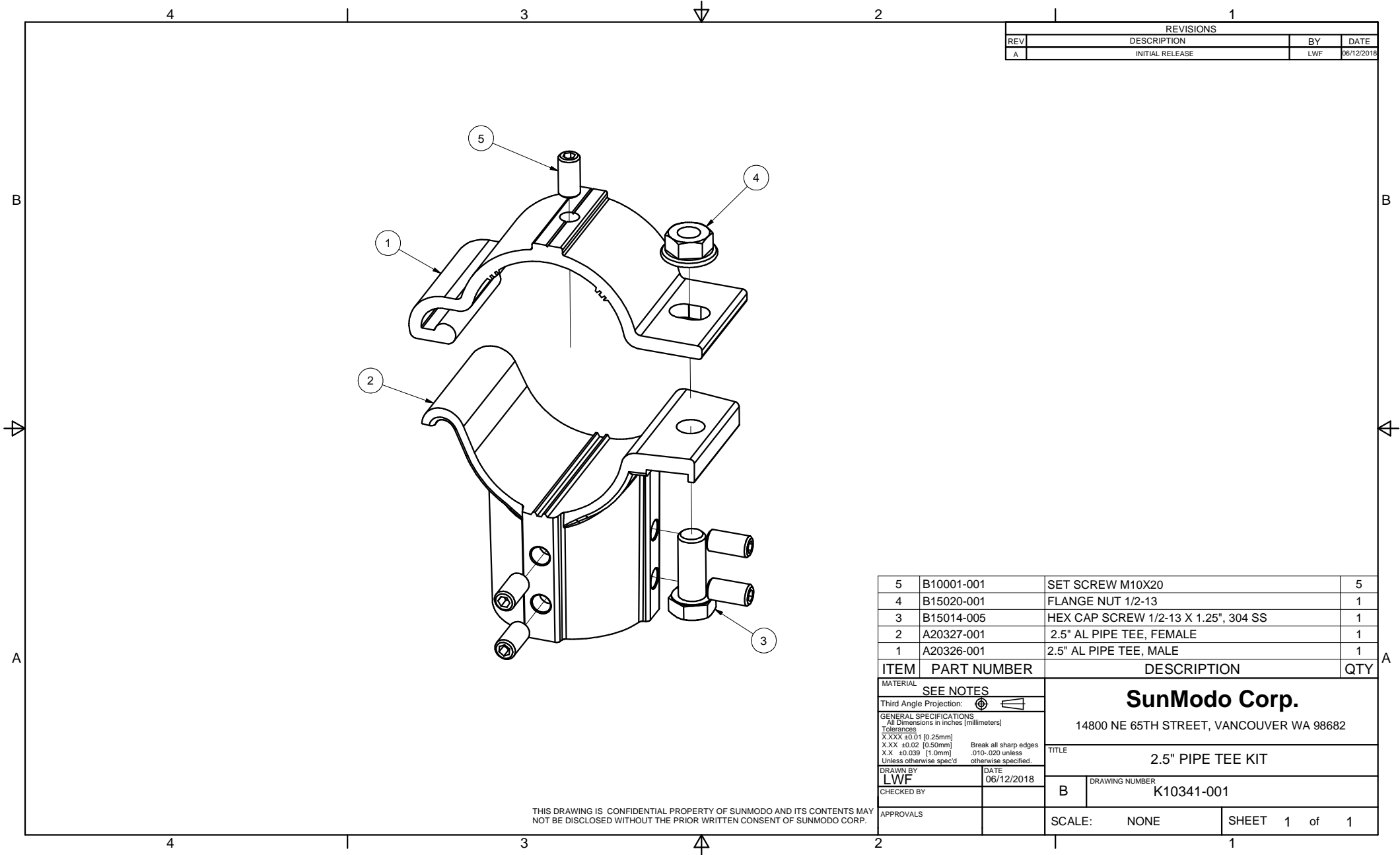

REVISIONS			
REV	DESCRIPTION	BY	DATE
A	INITIAL RELEASE	LWF	06/12/2018

5	B10001-001	SET SCREW M10X20	5
4	B15020-001	FLANGE NUT 1/2-13	1
3	B15014-005	HEX CAP SCREW 1/2-13 X 1.25", 304 SS	1
2	A20327-001	2.5" AL PIPE TEE, FEMALE	1
1	A20326-001	2.5" AL PIPE TEE, MALE	1
ITEM	PART NUMBER	DESCRIPTION	QTY

MATERIAL		SEE NOTES	
Third Angle Projection:			
GENERAL SPECIFICATIONS		<p>SunModo Corp. 14800 NE 65TH STREET, VANCOUVER WA 98682</p>	
All Dimensions in inches [millimeters] Tolerances X.XXX ±0.01 [0.25mm] X.XX ±0.02 [0.50mm] X.X ±0.039 [1.0mm] Unless otherwise spec'd			
TITLE		2.5" PIPE TEE KIT	
DRAWN BY	DATE	DRAWING NUMBER	
LWF	06/12/2018	B K10341-001	
CHECKED BY			
APPROVALS		SCALE: NONE	SHEET 1 of 1

THIS DRAWING IS CONFIDENTIAL PROPERTY OF SUNMODO AND ITS CONTENTS MAY NOT BE DISCLOSED WITHOUT THE PRIOR WRITTEN CONSENT OF SUNMODO CORP.

REVISIONS			
REV	DESCRIPTION	BY	DATE
A	INITIAL RELEASE	LWF	06/12/2018

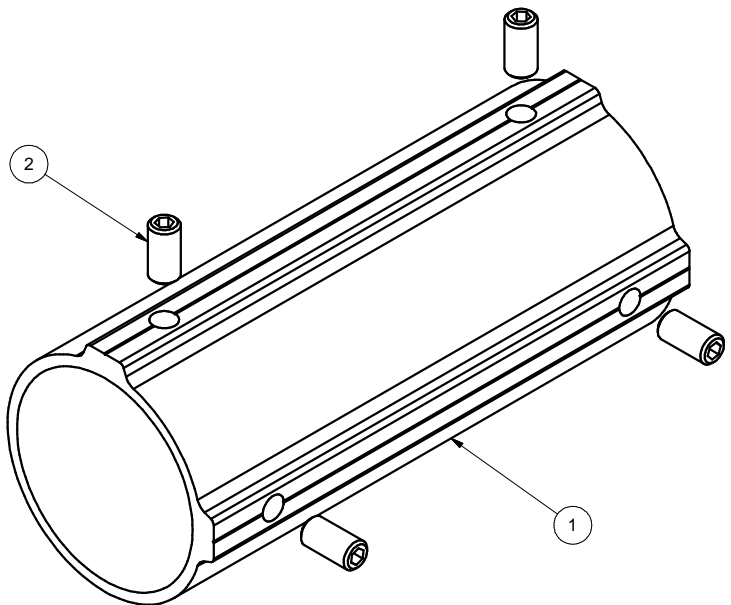

2	B10001-001	SET SCREW M10X20	4
1	A20328-001	2.5" PIPE SPLICE	1
ITEM	PART NUMBER	DESCRIPTION	QTY
MATERIAL		SEE NOTES	
Third Angle Projection:			
GENERAL SPECIFICATIONS		SunModo Corp. 14800 NE 65TH STREET, VANCOUVER WA 98682	
All Dimensions in inches [millimeters] Tolerances X.XXX ±0.01 [0.25mm] X.XX ±0.02 [0.50mm] X.X ±0.039 [1.0mm] Unless otherwise spec'd		Break all sharp edges .010-.020 unless otherwise specified.	
DRAWN BY		TITLE	
LWF		2.5" PIPE SPLICE KIT	
CHECKED BY		DRAWING NUMBER	
		B K10342-001	
APPROVALS		SCALE: NONE SHEET 1 of 1	

THIS DRAWING IS CONFIDENTIAL PROPERTY OF SUNMODO AND ITS CONTENTS MAY NOT BE DISCLOSED WITHOUT THE PRIOR WRITTEN CONSENT OF SUNMODO CORP.

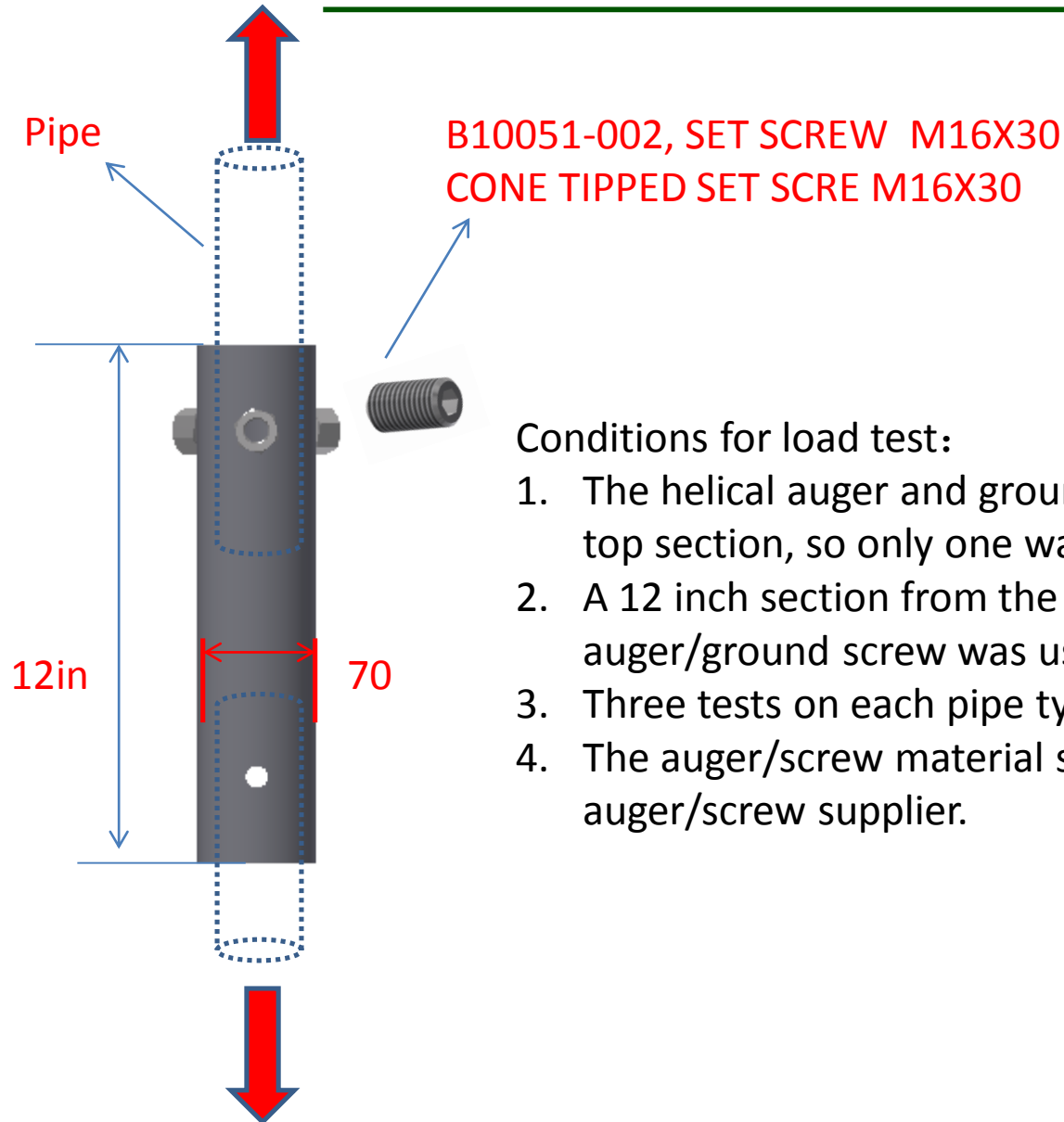

Conditions for load test:

1. The helical auger and ground screw use the same top section, so only one was used for testing
2. A 12 inch section from the top of the auger/ground screw was used
3. Three tests on each pipe type was used
4. The auger/screw material supplied by the auger/screw supplier.