

|                   |                   |
|-------------------|-------------------|
| Model Code        | ASCE 7-16         |
| Exposure Category | C                 |
| Wind Speed        | 135 mph and Lower |
| Ground Snow Load  | 60 PSF and Lower  |
| Tilt              | UP TO 35 DEG      |

- NOTES: UNLESS OTHERWISE SPECIFIED**
- THIS DRAWING IS NOT FOR CONSTRUCTION UNTIL ENGINEERING HAS REVIEWED AND STAMPED THIS DOCUMENT.
  - DIMENSIONS SHOWN ARE INCHES.
  - THE SELF-BONDING SYSTEM AND SINGLE GROUND LUG IS FOR USE WITH PV MODULES THAT HAVE A MAXIMUM SERIES FUSE RATING OF 30A.
  - MATERIALS ARE AS SPECIFIED OR EQUIVALENT:  
HARDWARE: 304 STAINLESS STEEL  
FABRICATED EXTRUDED PARTS: 6005-T5 ALUMINUM ALLOY  
FABRICATED DIE CAST PARTS: ANSI/AA A380 ALUMINUM ALLOY  
STEEL PIPE: SCHEDULE 40 GALVANIZED  
ALUMINUM PIPE: SCHEDULE 10 ANODIZED
  - THE MAXIMUM PERMISSIBLE LENGTH OF ANY STRUCTURE SHALL BE 200 FT. FOR SYSTEMS USING A SHARED RAIL CONFIGURATION, A THERMAL BREAK IS REQUIRED IN THE RAIL EVERY 40 FT. PER THE DRAWING DETAILS.
  - SUNTURF SYSTEM CONFIGURATIONS:  
PANEL ARRANGEMENT: 4LXN, 3LXN, OR 2PXN.  
TILT ANGLE: UP TO 35DEG.  
FOUNDATION TYPE: GSM, AGM, BGM, OR PGM.
  - PANEL DIMENSIONS ARE AS FOLLOWS:  
STANDARD PANEL (SP): MAX AREA: 3444 in<sup>2</sup>  
LARGE FORMAT (LF): MAX AREA: 3825 in<sup>2</sup>  
PANEL FRAME HEIGHTS: 30mm TO 50mm.
  - FOUNDATION TYPES:  
GSM = GROUND SCREW GROUND MOUNT  
AGM = HELICAL AUGER GROUND MOUNT  
PGM = POST-IN-CONCRETE GROUND MOUNT  
BSM = BALLAST GROUND MOUNT
  - SEE LETTER PROVIDED BY VECTOR STRUCTURAL ENGINEERING, LLC FOR FOUNDATION DESIGN AND LOAD TESTING REQUIREMENTS.

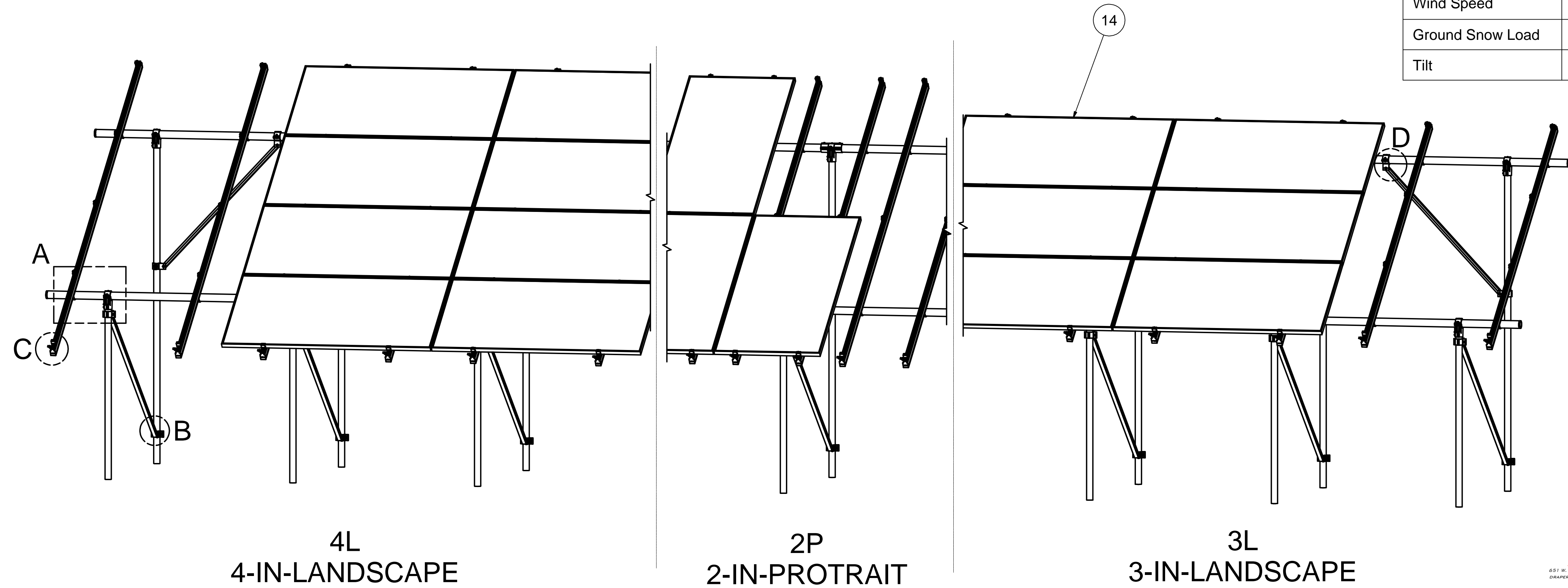

4L  
4-IN-LANDSCAPE

2P  
2-IN-PROTRAIT

3L  
3-IN-LANDSCAPE

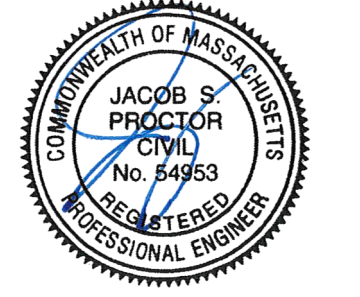

Vector Structural Engineering requires that we review each site-specific install, and we are not liable for installs at site-specific locations we have not reviewed. This document does not address site-specific installations.

01/30/2024  
VSE Project Number: U2716.0350.221

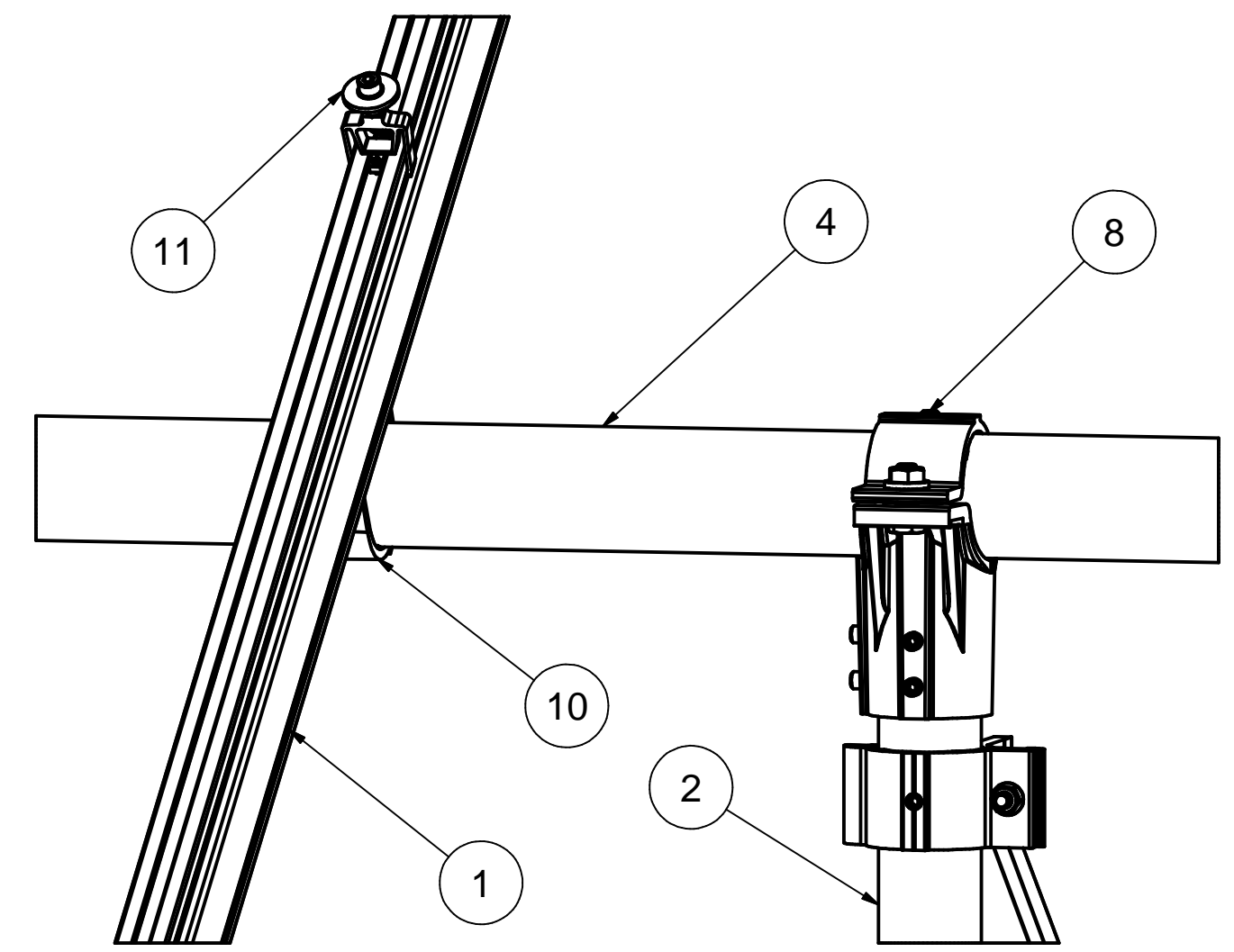

DETAIL A

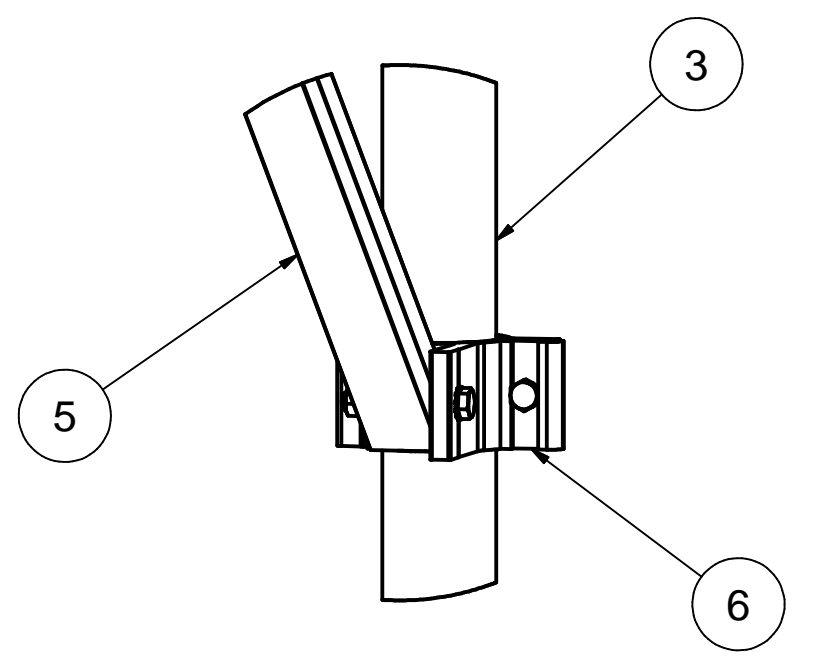

DETAIL B

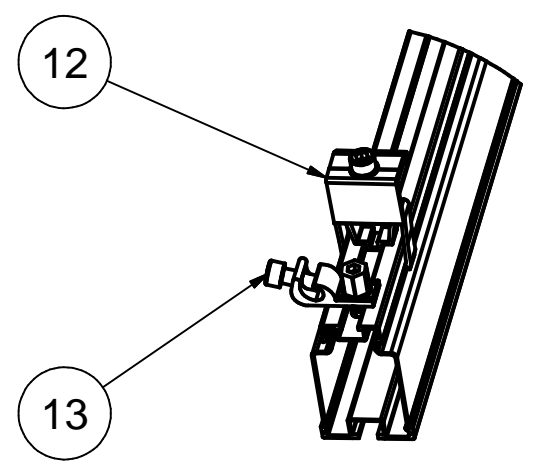

DETAIL C

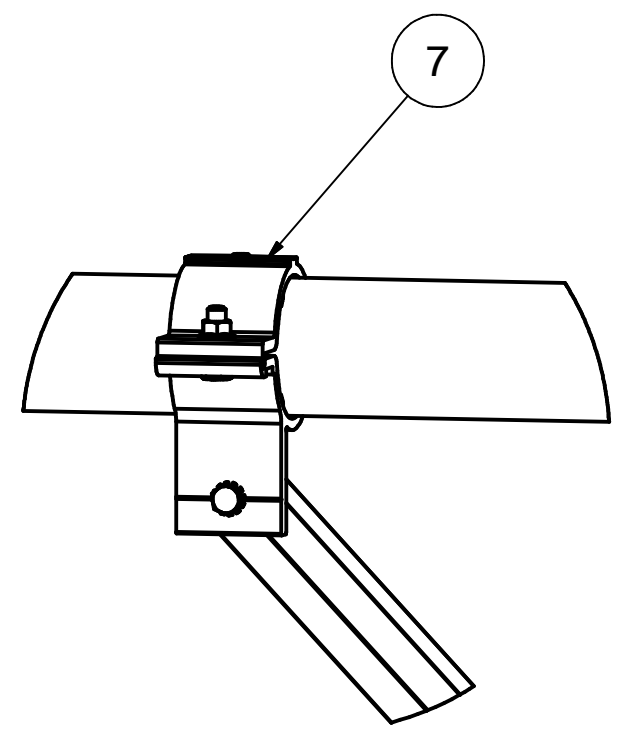

DETAIL D

| ITEM | PART NUMBER        | DESCRIPTION                           | QTY |
|------|--------------------|---------------------------------------|-----|
| 14   |                    | PANEL                                 |     |
| 13   | K10469-001         | SMR GROUND LUG KIT                    |     |
| 12   | K10418-XXX         | SMR POP-ON END CLAMP KIT,CLEAR        |     |
| 11   | K10417-XXX         | MID CLAMP,SMR POP-ON,CLEAR            |     |
| 10   | K10343-005         | 2.5" AL PIPE U-CLAMP KIT              |     |
| 9    | K10342-001         | 2.5" PIPE SPLICE KIT                  |     |
| 8    | K10341-002         | 2.5" PIPE TEE KIT                     |     |
| 7    | K10222-001         | 2.5" PIPE CLAMP KIT                   |     |
| 6    | K10219-001         | 2" AL PIPE CLAMP KIT                  |     |
| 5    | A50164-XXX         | 1.5" SQ. STL TUBE BRACE, L=XXX        |     |
| 4    | A21168-XXX         | PIPE, HSS, 2.875" OD X 12 GAUGE,L=XXX |     |
| 3    | A21165-XXX (REAR)  | PIPE, HSS, 2.375" OD X 12 GAUGE,L=XXX |     |
| 2    | A21165-XXX (FRONT) | PIPE, HSS, 2.375" OD X 12 GAUGE,L=XXX |     |
| 1    | A20444-XXX         | SMR300 RAIL, L=XXX                    |     |

MATERIAL: SEE BOM

Third Angle Projection:

GENERAL SPECIFICATIONS  
All Dimensions in inches (millimeters)  
Tolerances:  
FRACTIONS (0.25mm)  
X.XX (0.10mm)  
X.XXX (0.05mm)  
X.XXX (0.025mm)  
OTHERWISE SPECIFIED

Break all sharp edges 0.10 (0.05) unless otherwise specified

DATE: 08/15/2022

DRAWN BY: KYV

CHECKED BY:

**SunModo Corp.**  
14800 NE 65TH STREET, VANCOUVER WA 98682

TITLE: PACKET A3

D: DRAWING NUMBER

SCALE: SHEET 1 of 5

THIS DRAWING IS CONFIDENTIAL PROPERTY OF SUNMODO AND ITS CONTENTS MAY NOT BE DISCLOSED WITHOUT THE PRIOR WRITTEN CONSENT OF SUNMODO CORP.

**NOTES: UNLESS OTHERWISE SPECIFIED**

1. APPROVED RAIL PROFILES - STANDARD PANELS  
A20288-XXX (HR300 RAIL), A20297-001 (END CAP),  
K10343-002 (U-CLAMP KIT);  
A20145-XXX (HR350 RAIL), A20285-001 (END CAP),  
K10343-001 (U-CLAMP KIT).
2. APPROVED RAIL PROFILES - OVERSIZE PANELS  
\* A20288-XXX (HR300 RAIL), A20297-001 (END CAP),  
K10343-002 (U-CLAMP KIT);  
\* A20145-XXX (HR350 RAIL), A20285-001 (END CAP),  
K10343-001 (U-CLAMP KIT).
3. K10224-XXX END CLAMP KIT OR K10299-XXX ADJ.  
END CLAMP KIT.

ALTERNATE(ALT) DETAILS  
HR300, HR350 RAIL PROFILES

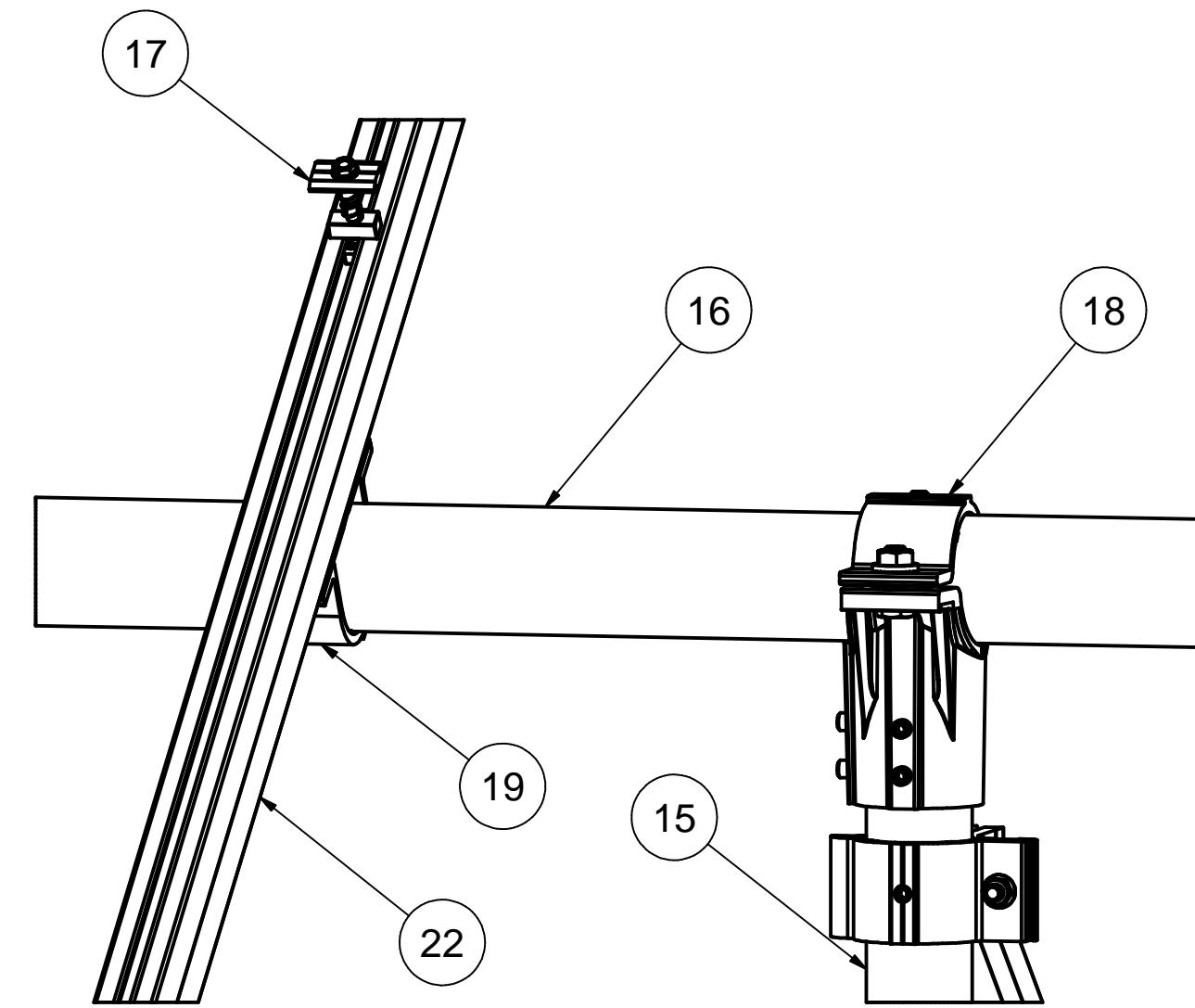

DETAIL A-ALT

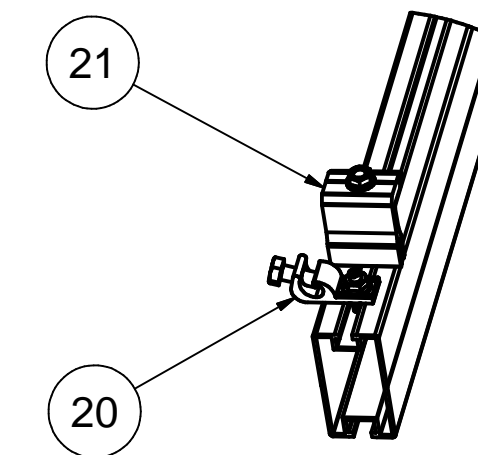

DETAIL C-ALT



Vector Structural Engineering requires that we review each site-specific install, and we are not liable for installs at site-specific locations we have not reviewed. This document does not address site-specific installations.

01/30/2024  
VSE Project Number: U2716.0350.221

| 22   |             | HELIO RAIL. VARIES PER NOTE 1 & 2                             |     |
|------|-------------|---|-----|
| 21   |             | END CLAMP KIT. VARIES PER NOTE 3                              |     |
| 20   | K10469-003  | HR GROUNDING LUG KIT  |     |
| 19   | K10343-XXX  | 2.5" AL PIPE U-CLAMP KIT                                      |     |
| 18   | K10341-002  | 2.5" PIPE TEE KIT   |     |
| 17   | K10180-001  | GROUNDING MID-CLAMP KIT WITH T COLLAR BOLT AND GROUNDING BASE |     |
| 16   | A21168-XXX  | PIPE, HSS, 2.875" OD X 12 GAUGE, L=XXX                        |     |
| 15   | A21165-XXX  | PIPE, HSS, 2.375" OD X 12 GAUGE, L=XXX                        |     |
| ITEM | PART NUMBER | DESCRIPTION   | QTY |

**SunModo Corp.**

TITLE  
PACKET A3

DRAWING NUMBER

D

SCALE: SHEET 2 of 5 REV

1

**NOTES:**  
 1. DIMENSIONS LABELED AS MAX ARE MAXIMUM ALLOWABLE AND MAY RESULT IN END POSTS BEING OUTSIDE ARRAY EDGES. MAXIMUM DIMENSIONS MAY BE REDUCED IF DESIRED.  
 2. SEE NOTE 7 OF COVER PAGE FOR PANEL SIZES.

**RAIL SPACING**  
 PER PANEL MANUFACTURER

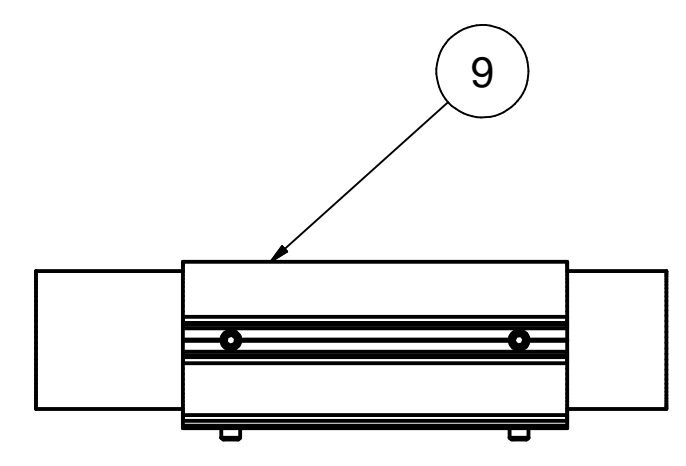

**DETAIL E**

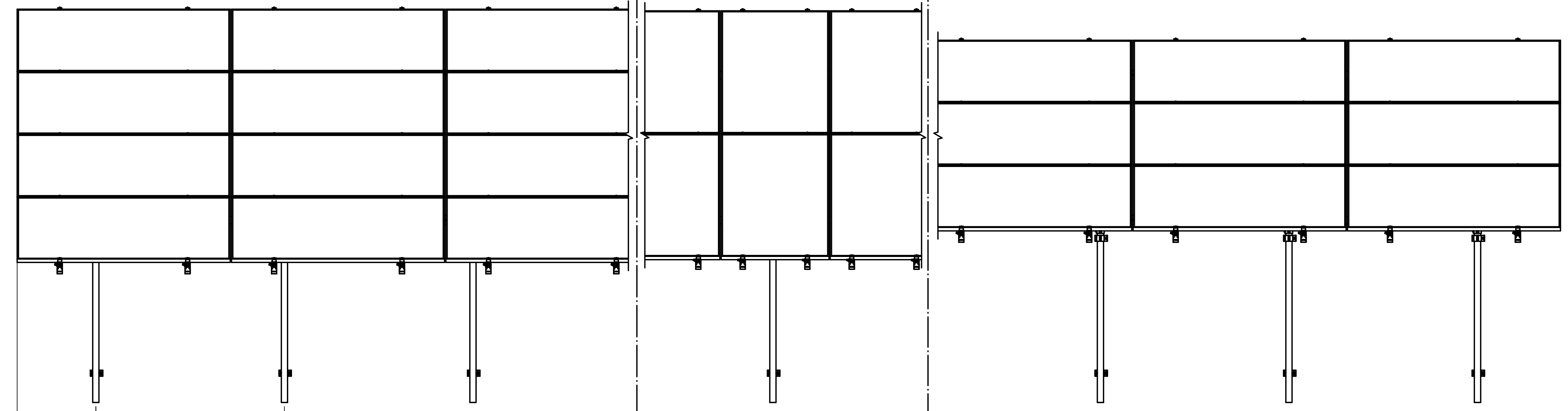
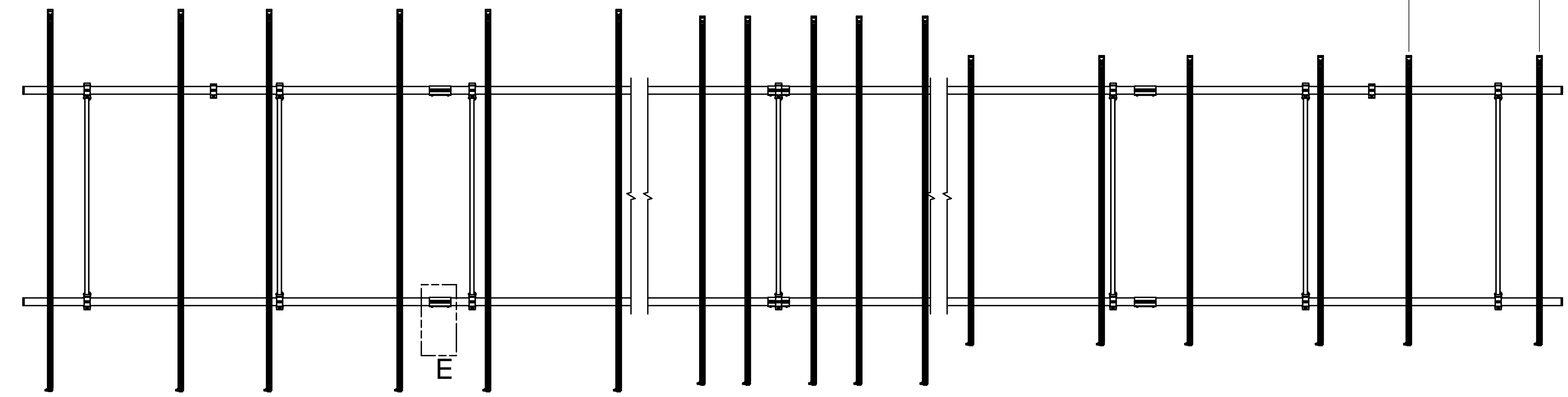

SP<sup>2</sup>: 28 MAX  
 LF<sup>2</sup>: 20 MAX

SP<sup>2</sup>: 72 MAX  
 LF<sup>2</sup>: 60 MAX

**4L**  
**4-IN-LANDSCAPE**

**2P**  
**2-IN-PROTRAIT**

**3L**  
**3-IN-LANDSCAPE**

Vector Structural Engineering requires that we review each site-specific install, and we are not liable for installs at site-specific locations we have not reviewed. This document does not address site-specific installations.

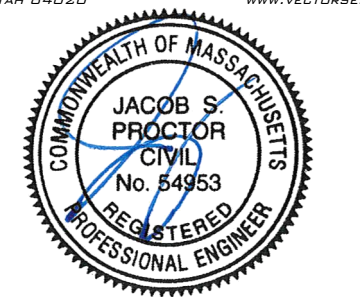

01/30/2024  
 VSE Project Number: U2716.0350.221

|                      |                  |
|----------------------|------------------|
| <b>SunModo Corp.</b> |                  |
| TITLE                | PACKET A3        |
| D                    | DRAWING NUMBER   |
| SCALE:               | SHEET 3 of 5 REV |

| DIMENSIONS - STANDARD PANEL |     |     |     |
|-----------------------------|-----|-----|-----|
| ITEM                        | 4L  | 2P  | 3L  |
| A                           | 172 | 166 | 130 |
| B                           | 38  | 35  | 17  |
| C                           | 55  | 54  | 43  |
| D                           | 111 | 109 | 99  |

| DIMENSIONS - LARGE FORMAT PANEL |     |     |     |
|---------------------------------|-----|-----|-----|
| ITEM                            | 4L  | 2P  | 3L  |
| A                               | 184 | 172 | 140 |
| B                               | 40  | 34  | 18  |
| C                               | 56  | 53  | 44  |
| D                               | 117 | 113 | 104 |

**NOTES**

1. DIMENSIONS IN TABLE ARE SHOWN AT MAXIMUM TILT & LEADING EDGE HEIGHT. PROJECTS WITH LOWER TILTS & LEADING EDGE HEIGHTS WILL RESULT IN REDUCED DIMENSIONS.
2. MAX DENOTES MAXIMUM PERMISSIBLE DIMENSIONS.
3. SEE NOTE 7 OF COVER PAGE FOR PANEL SIZES.
4. SEE LETTER PROVIDED BY VECTOR STRUCTURAL ENGINEERING, LLC FOR REQUIRED LOAD TESTING, FOUNDATION AND ANCHORAGE REQUIREMENTS, AND OTHER INFORMATION NOT SHOWN.
5. SP DENOTES STANDARD MODULE & LF DENOTES LARGE FORMAT MODULES.

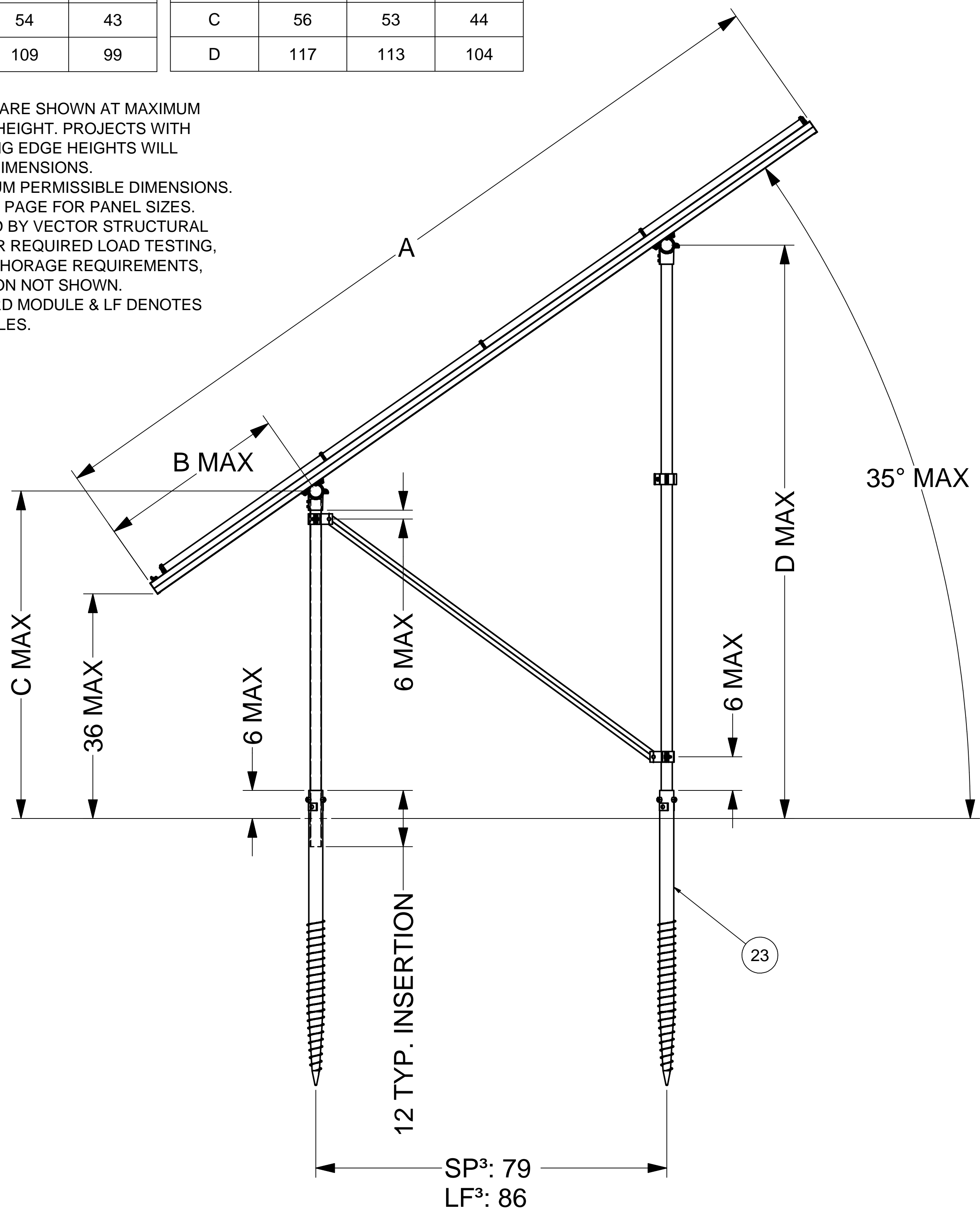

**GROUND SCREW GROUND MOUNT (GSM)<sup>4</sup>**

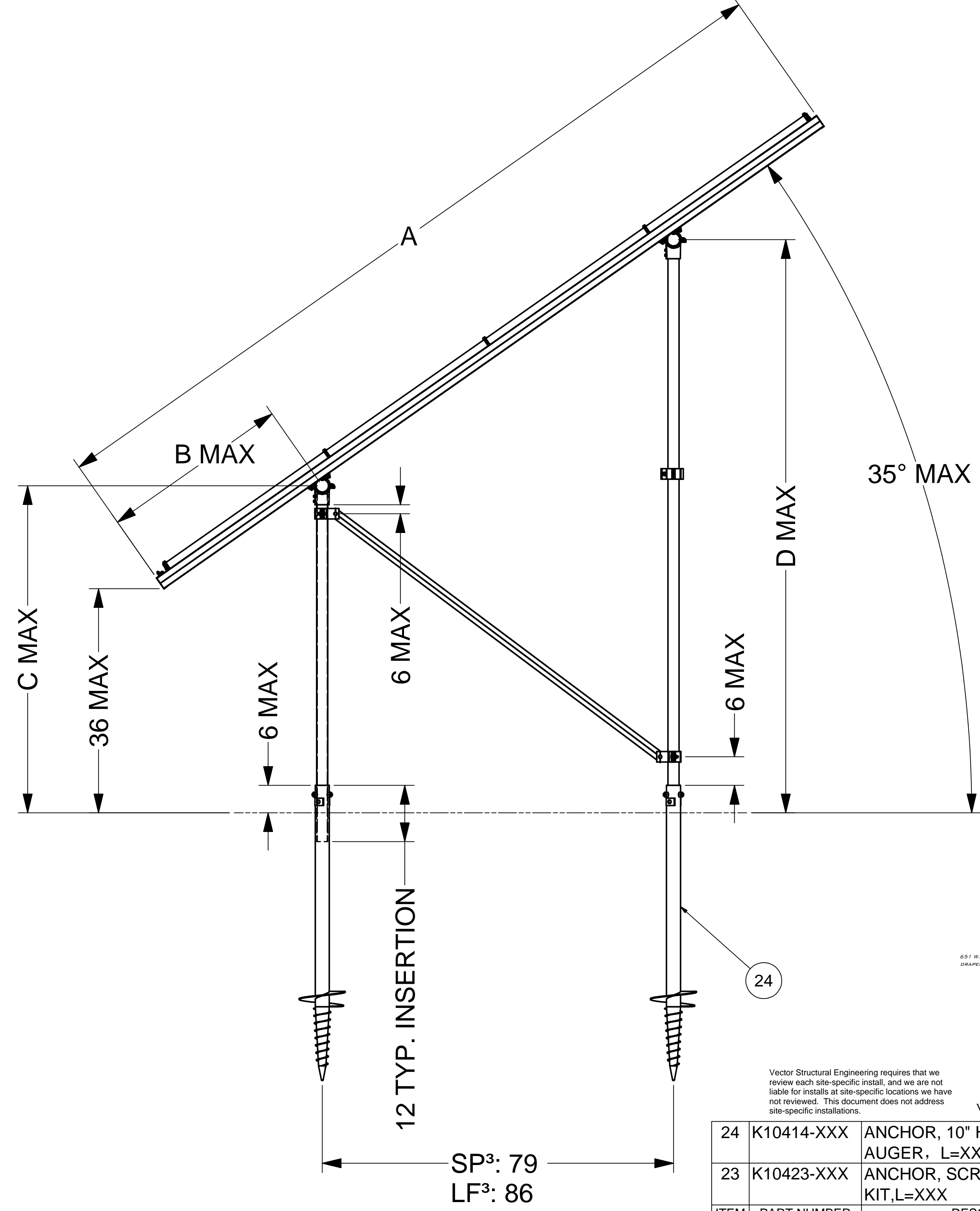

**AUGER GROUND MOUNT (AGM)<sup>4</sup>**



Vector Structural Engineering requires that we review each site-specific install, and we are not liable for installs at site-specific locations we have not reviewed. This document does not address site-specific installations.

01/30/2024  
VSE Project Number: U2716.0350.221

| ITEM | PART NUMBER | DESCRIPTION                          | QTY |
|------|-------------|--------------------------------------|-----|
| 24   | K10414-XXX  | ANCHOR, 10" HELIX SCREW AUGER, L=XXX |     |
| 23   | K10423-XXX  | ANCHOR, SCREW AUGER KIT, L=XXX       |     |

|                      |                  |
|----------------------|------------------|
| <b>SunModo Corp.</b> |                  |
| TITLE<br>PACKET A3   |                  |
| DRAWING NUMBER       |                  |
| SCALE:               | SHEET 4 of 5 REV |

| DIMENSIONS - STANDARD PANEL |     |     |     |
|-----------------------------|-----|-----|-----|
| ITEM                        | 4L  | 2P  | 3L  |
| A                           | 172 | 166 | 130 |
| B                           | 38  | 35  | 17  |
| C                           | 55  | 54  | 43  |
| D                           | 111 | 109 | 99  |

| DIMENSIONS - LARGE FORMAT PANEL |     |     |     |
|---------------------------------|-----|-----|-----|
| ITEM                            | 4L  | 2P  | 3L  |
| A                               | 184 | 172 | 140 |
| B                               | 40  | 34  | 18  |
| C                               | 56  | 53  | 44  |
| D                               | 117 | 113 | 104 |

**NOTES**

1. DIMENSIONS IN TABLE ARE SHOWN AT MAXIMUM TILT & LEADING EDGE HEIGHT. PROJECTS WITH LOWER TILTS & LEADING EDGE HEIGHTS WILL RESULT IN REDUCED DIMENSIONS.
2. MAX DENOTES MAXIMUM PERMISSIBLE DIMENSIONS.
3. SEE NOTE 7 OF COVER PAGE FOR PANEL SIZES.
4. K10268-005 (2" PIPE BASE KIT) OR K10302-001 (2" PIPE BASE KIT)
5. SEE LETTER PROVIDED BY VECTOR STRUCTURAL ENGINEERING, LLC FOR REQUIRED LOAD TESTING, FOUNDATION AND ANCHORAGE REQUIREMENTS, AND OTHER INFORMATION NOT SHOWN.
6. SP DENOTES STANDARD MODULE & LF DENOTES LARGE FORMAT MODULES.

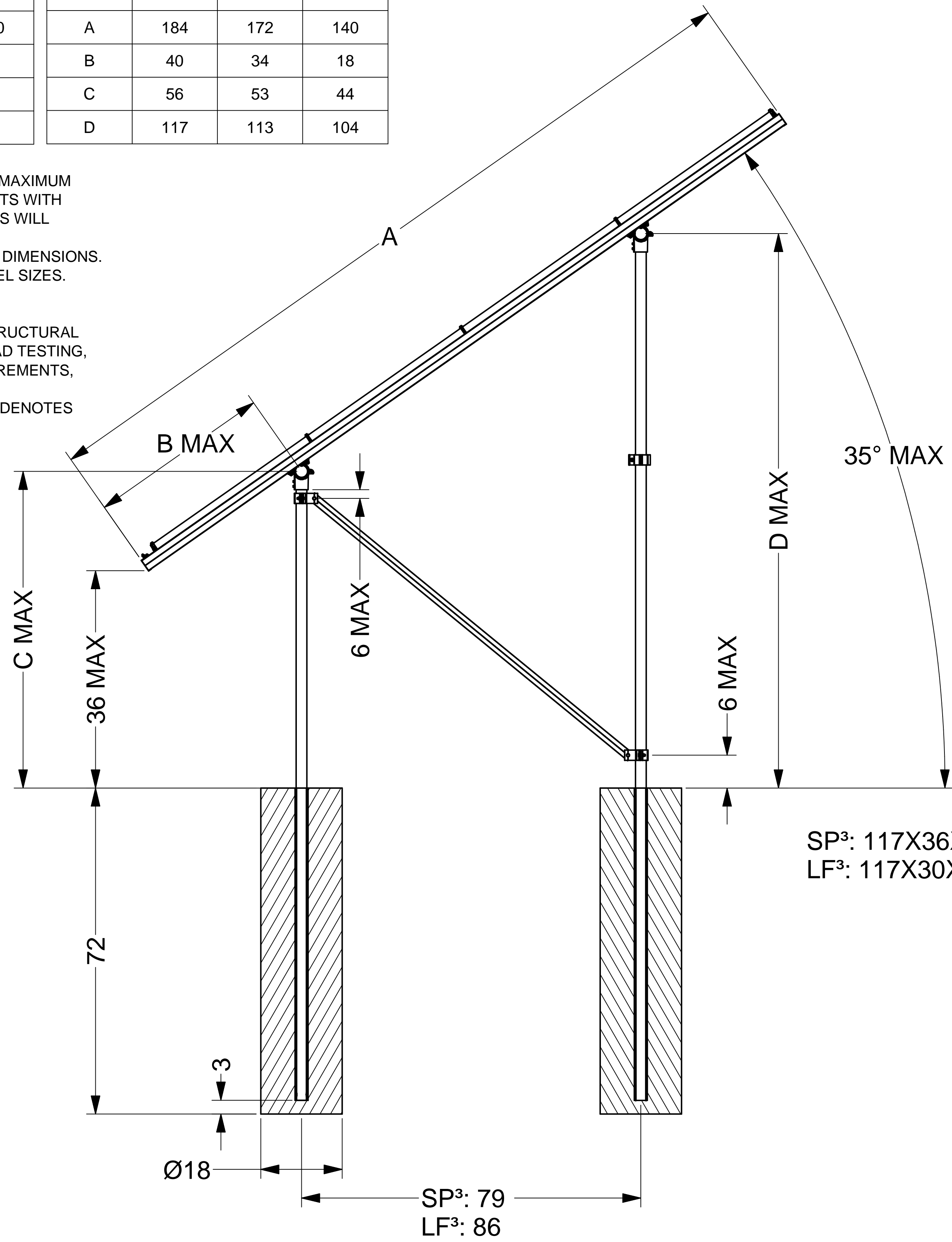

**POST-IN-CONCRETE GROUND MOUNT (PGM)<sup>5</sup>**

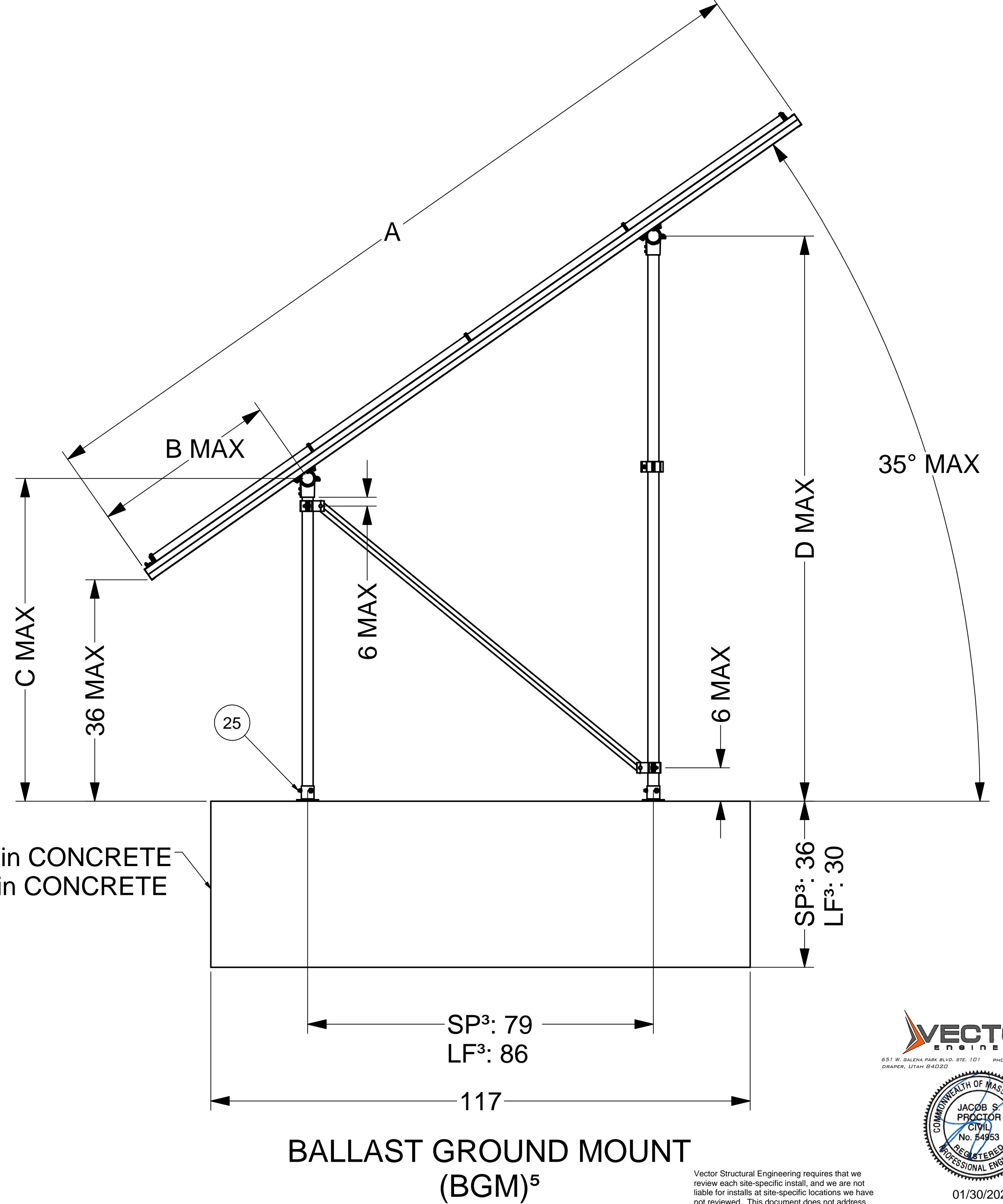

**BALLAST GROUND MOUNT (BGM)<sup>5</sup>**

SP<sup>3</sup>: 117X36X36 in CONCRETE  
LF<sup>3</sup>: 117X30X30 in CONCRETE

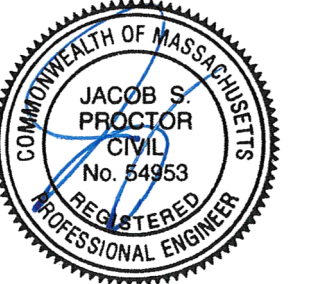

Vector Structural Engineering requires that we review each site-specific install, and we are not liable for installs at site-specific locations we have not reviewed. This document does not address site-specific installations.  
01/30/2024  
VSE Project Number: U2716.0350.221

|        |             |                            |                |
|--------|-------------|----------------------------|----------------|
| 25     |             | POST BASE. VARIES PER NOTE |                |
| ITEM   | PART NUMBER | DESCRIPTION                | QTY            |
|        |             | <b>SunModo Corp.</b>       |                |
|        |             | TITLE                      | PACKET A3      |
|        |             | D                          | DRAWING NUMBER |
| SCALE: |             | SHEET 5 of 5               | REV            |