



Project Number: U2716-0350-221

September 8, 2022

Sunmodo
14800 NE 65th Street
Vancouver, WA 98682

**REFERENCE: Sunmodo Sunturf Ground Mount A3
Ground Mount PV Array Installation w/ Large Format Panels**

To Whom It May Concern:

Per request of Sunmodo, we have been asked to prepare the structural design of a ground-mounted PV solar array system with several foundation options as shown in the attached calculations. The adopted building code in this jurisdiction is the International Building Code, 2018 Edition (2018 IBC). Vector Structural Engineering requires that we review each site-specific install, and we are not liable for installs at site specific locations we have not reviewed. The following design parameters are used in our analysis:

- Minimum Design Loads for Buildings and Other Structures (ASCE 7-16)
- Design wind speed for risk category I structures: 135 mph
- Wind exposure: C
- Ground snow load: 60 psf
- The ground screws and helical piers must be tested to 1.5 times uplift and 2.0 times lateral reactions found in the table below. A minimum of one ground screw or helical pier must be tested.

Load (ASD)	Value (lbs)	Factor of Safety	Test Value (lbs)
UPLIFT	2651	1.5	3977
LATERAL	1806	2	3612

Foundation concrete shall have a minimum compressive strength of 2500 psi at 28 days. Cement for all concrete shall be Type I or II with a minimum of 6% entrained air with a water/cement ratio of 0.50. Maximum aggregate size shall be 3/4". No special inspection of concrete strength is required.

Footings are designed based on an allowable soil bearing pressure of 1500 psf an allowable skin friction of 250 psf, an allowable lateral bearing pressure of 150 pcf, and a coefficient of friction of 0.3. Vector Structural Engineering strongly recommends independent soils testing be performed by a licensed geotechnical engineer to verify the assumed soil parameters.

All ground mounts are to be installed per manufacturer’s recommendations. The use of solar panel support span tables provided by the manufacturer is allowed only where the site conditions and solar panel configuration match the description of the span tables. Electrical engineering is beyond our scope. All work performed must be in accordance with accepted industry-wide methods and applicable safety standards. Vector Structural Engineering assumes no responsibility for improper installation of the solar panels.

Very truly yours,

VECTOR STRUCTURAL ENGINEERING, LLC

Jacob Proctor, P.E.
License: 25833 - Expires: 12/31/2023
Project Engineer

Enclosures

JSP/mih



09/08/2022



JOB NO. U2716-093-191
PROJECT SUNMODO SUNTURF GROUND MOUNTS A3
SUBJECT ALL OPTIONS

651 W GALENA PARK BLVD. #101 (801) 990-1775
DRAPER, UTAH 84020 (801) 990-1776 FAX

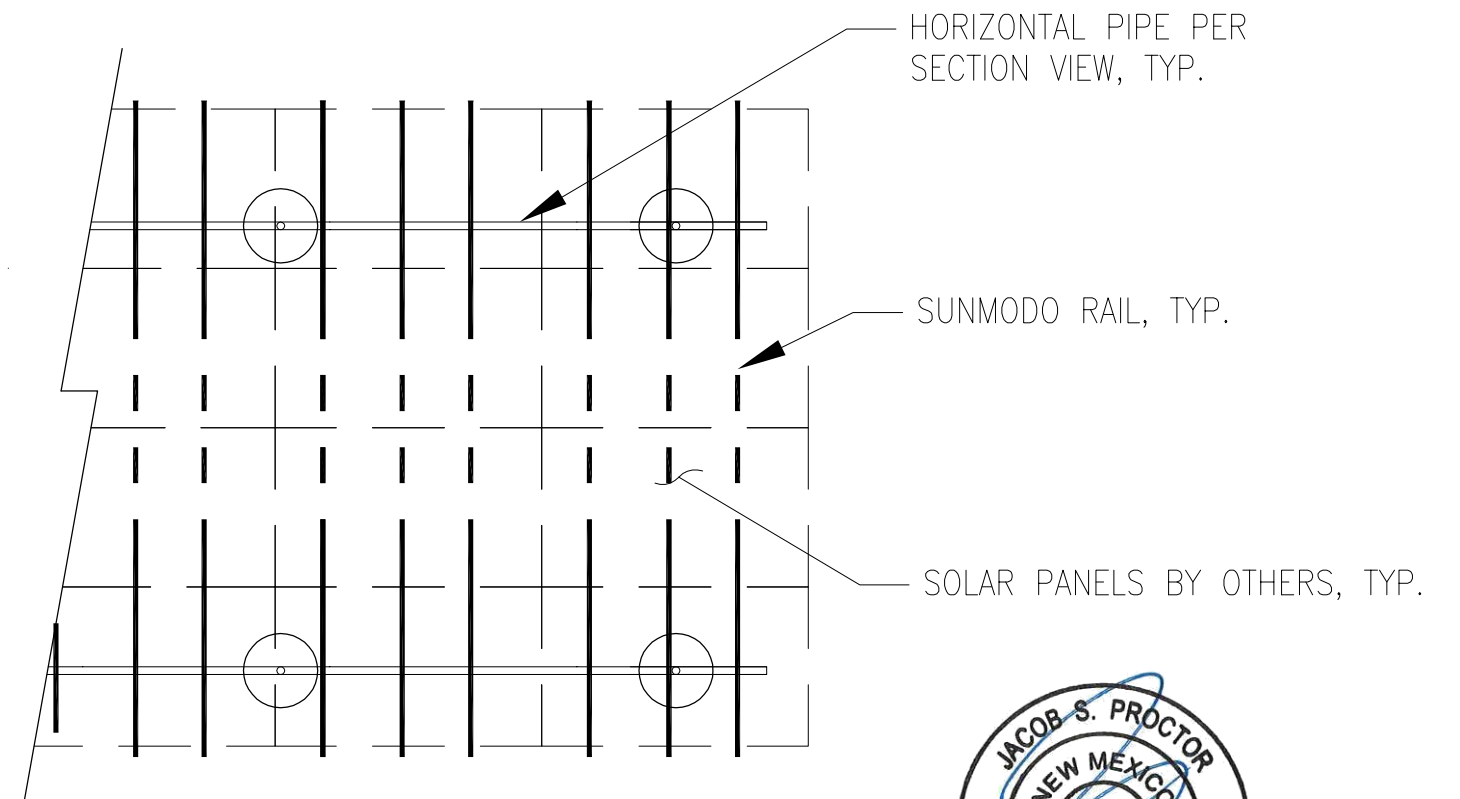
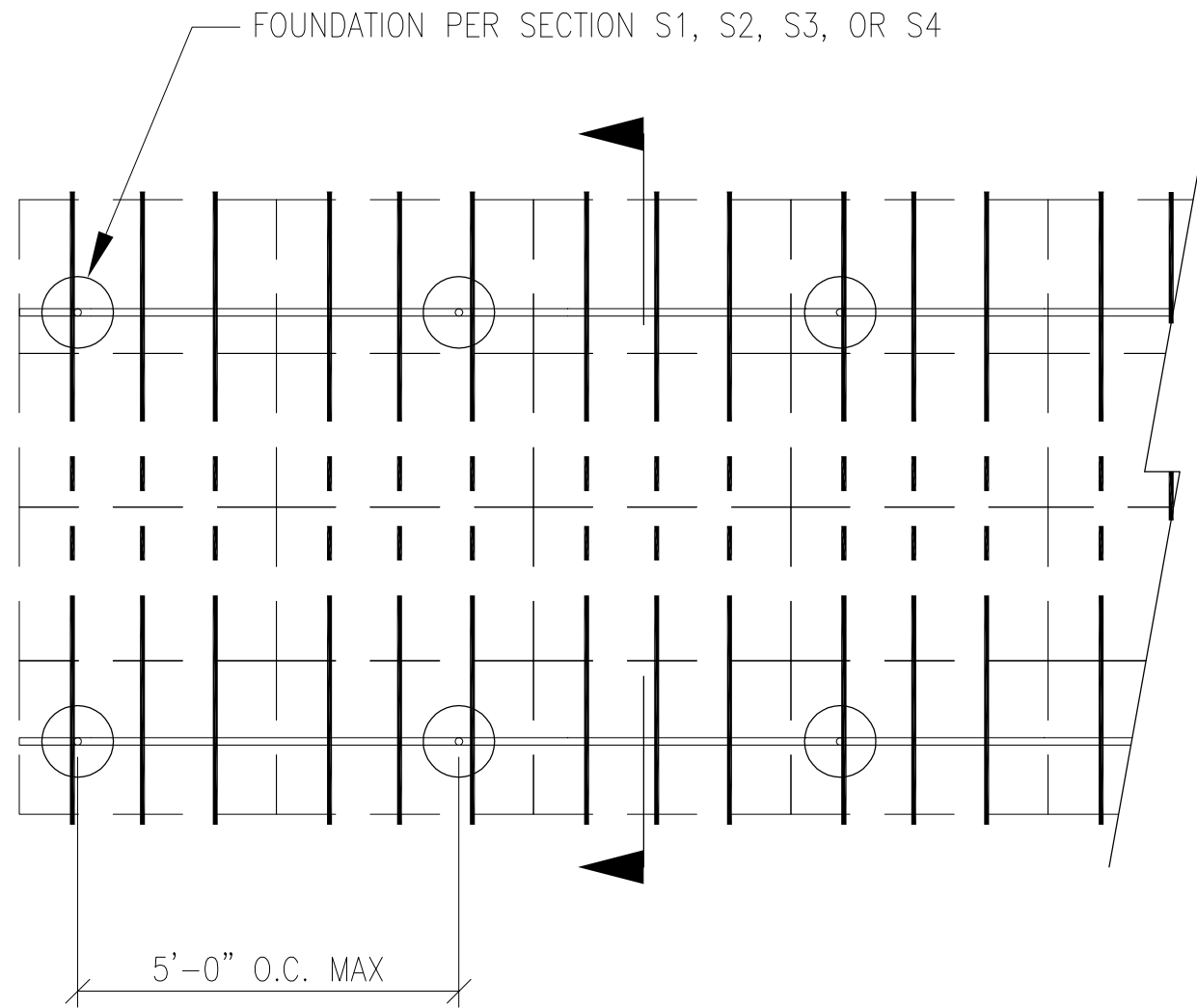

09/08/2022

PV ARRAY PLAN

N.T.S.

P1

PROJECT SUNMODO SUNTURF GROUND MOUNTS A3

SUBJECT DRILLED PIER OPTION

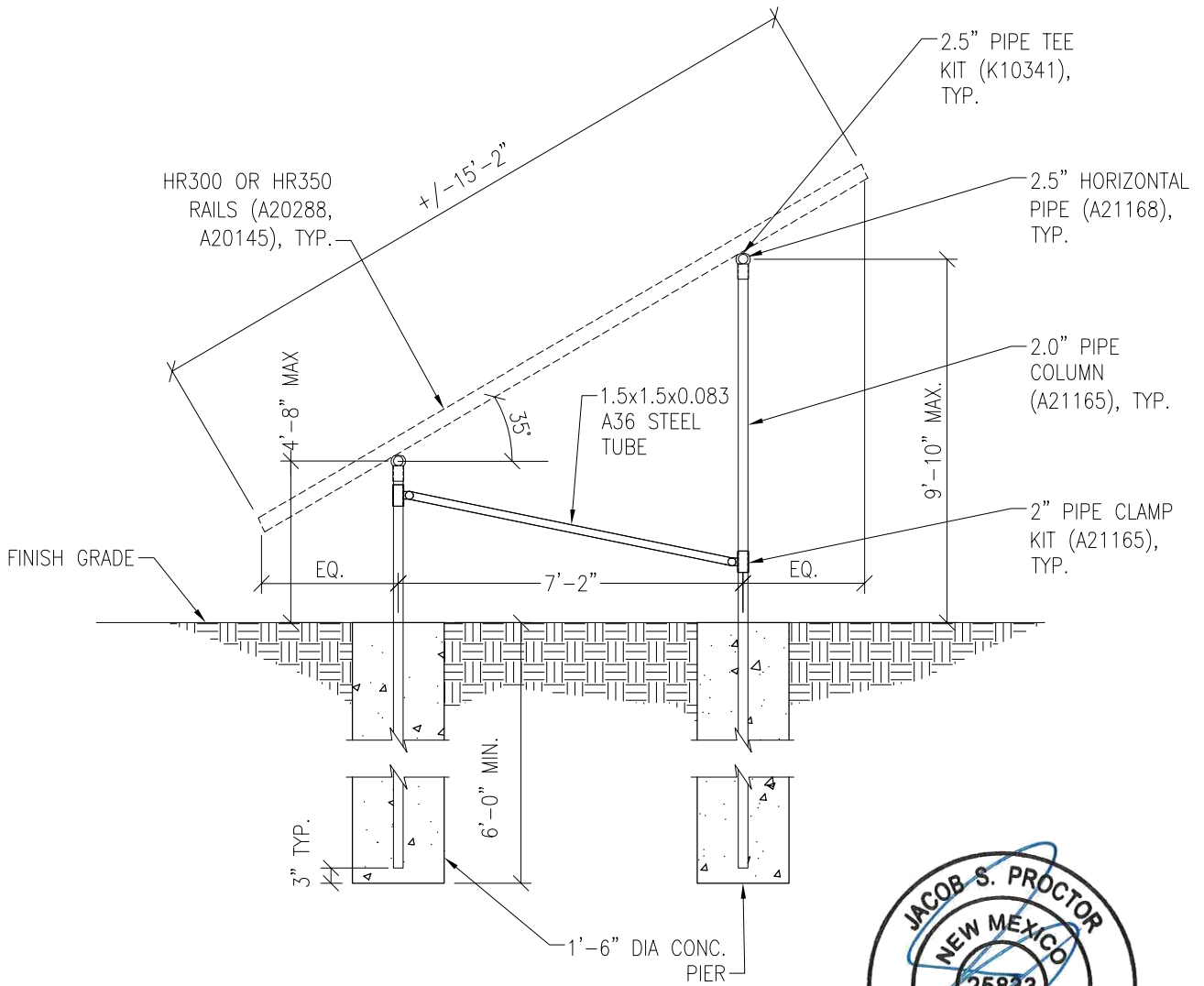

09/08/2022

Vector Engineers requires that we review each site specific install and is not liable for installs at site specific locations we have not reviewed.

PV ARRAY SECTION

N.T.S.

S1

PROJECT SUNMODO SUNTURF GROUND MOUNTS A3

SUBJECT HELICAL PIER OPTION

NOTES:

1. For ground mount components see Section S1.
2. A minimum of (1) helical pier must be load-tested as follows:
 - 2.1. Safety factor for uplift = 1.5,
 - 2.2. Safety factor for lateral loads = 2.0
 - 2.3. Upward deflection limit = 1/2"
 - 2.4. Lateral deflection limit = 1"
 - 2.5. The load tests must be performed by an approved contractor.

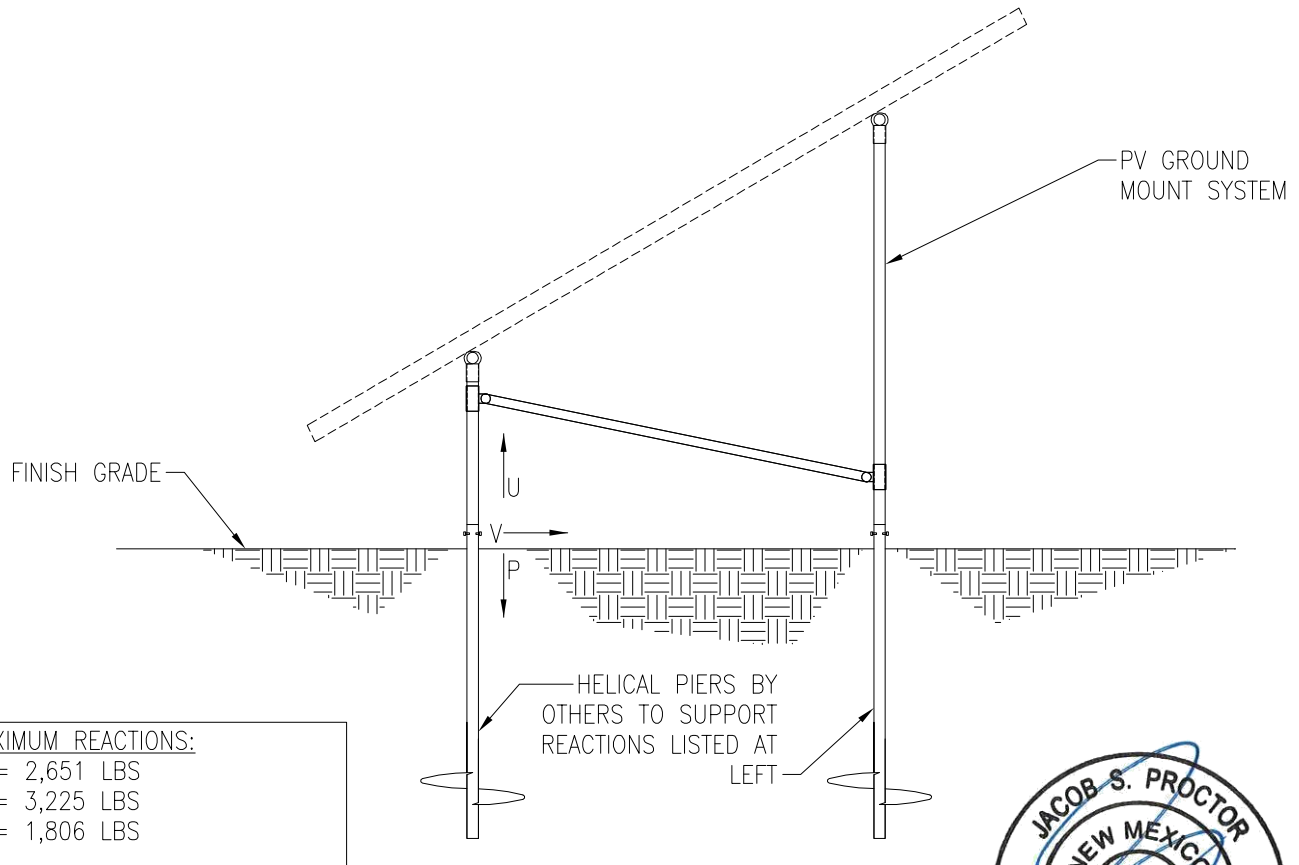

MAXIMUM REACTIONS:
 U = 2,651 LBS
 P = 3,225 LBS
 V = 1,806 LBS



09/08/2022

Vector Engineers requires that we review each site specific install and is not liable for installs at site specific locations we have not reviewed.

PV ARRAY SECTION

N.T.S.

S2

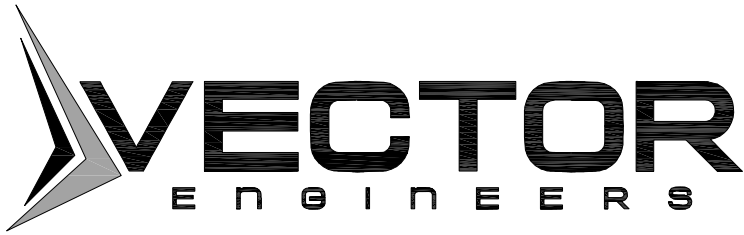

JOB NO. U2716-093-191

PROJECT SUNMODO SUNTURF GROUND MOUNTS A3

SUBJECT GROUND SCREW OPTION

NOTES:

1. For ground mount components see Section S1.
2. A minimum of (1) ground screw must be load-tested as follows:
 - 2.1. Safety factor for uplift = 1.5,
 - 2.2. Safety factor for lateral loads = 2.0
 - 2.3. Upward deflection limit = 1/2"
 - 2.4. Lateral deflection limit = 1"
 - 2.5. The load tests must be performed by an approved contractor.

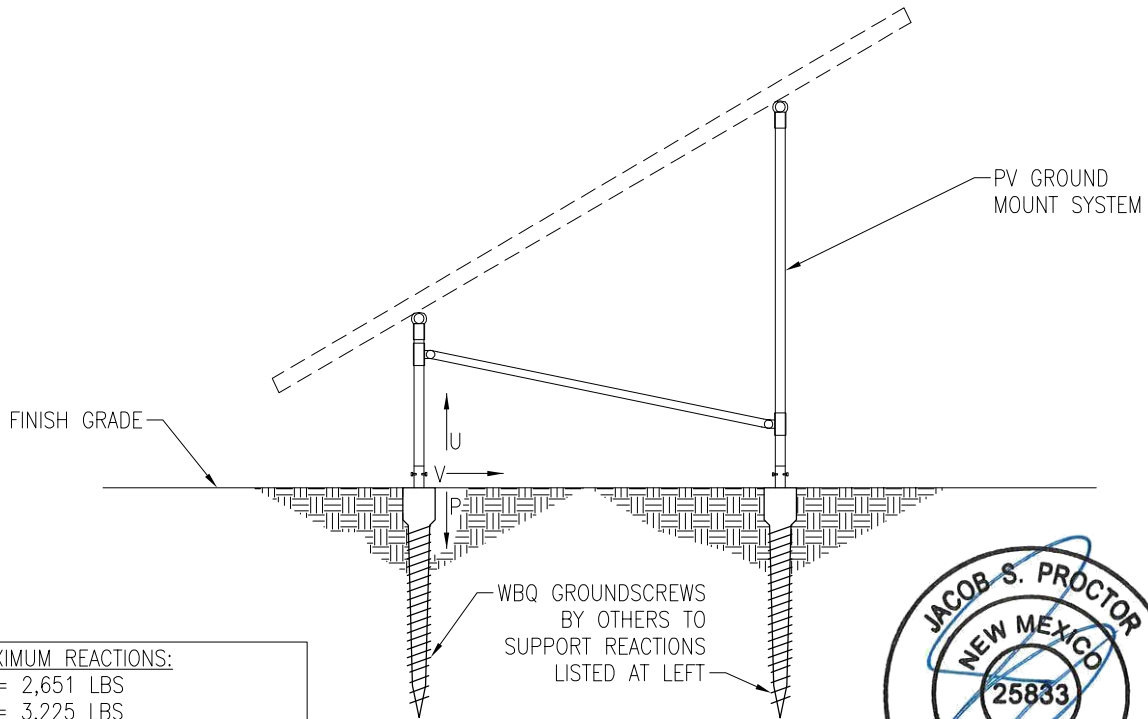

MAXIMUM REACTIONS:
 U = 2,651 LBS
 P = 3,225 LBS
 V = 1,806 LBS



09/08/2022

Vector Engineers requires that we review each site specific install and is not liable for installs at site specific locations we have not reviewed.

PV ARRAY SECTION

N.T.S.

S3

651 W GALENA PARK BLVD. #101
 DRAPER, UTAH 84020

(801) 990-1775
 (801) 990-1776 FAX

WWW.VECTORSE.COM



JOB NO. U2716-093-191

PROJECT SUNMODO SUNTURF GROUND MOUNTS A3

SUBJECT BALLASTED BLOCK OPTION

NOTES:

1. For ground mount components see Section S1.

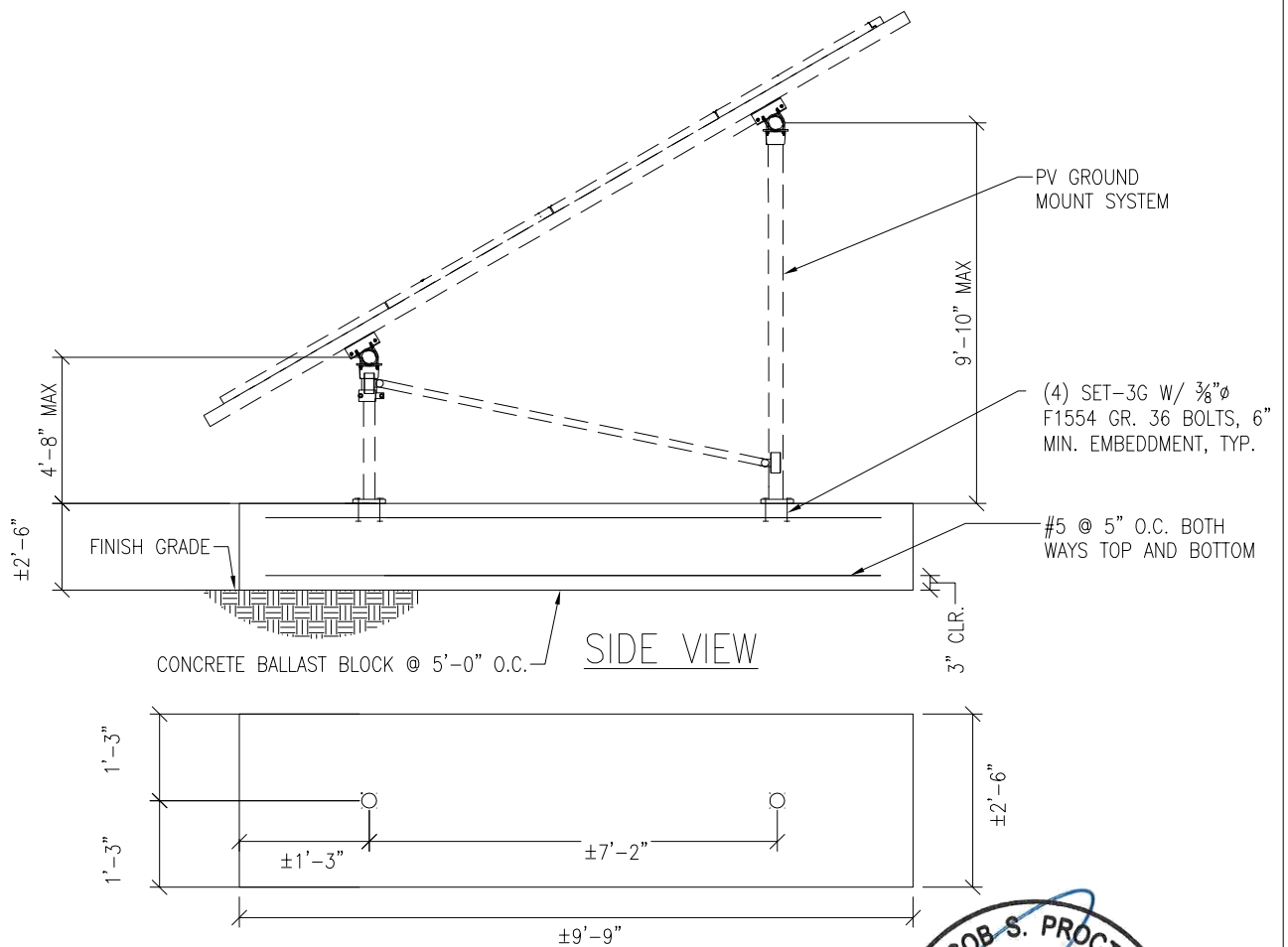

Vector Engineers requires that we review each site specific install and is not liable for installs at site specific locations we have not reviewed.

PV ARRAY SECTION

N.T.S.

09/08/2022

S4

651 W GALENA PARK BLVD. #101
DRAPER, UTAH 84020

(801) 990-1775
(801) 990-1776 FAX

WWW.VECTORSE.COM



JOB NO.: U2716-093-191

DESIGNED: STB

DATE: 07/23/19

PROJECT: A3 – Sunmodo Sunturf GM

SUBJECT: Snow Load

SNOW LOAD (S):

ASCE 7 Standard:	10	
Panel Slope from Horizontal [°]:	35.0	
Snow Ground Load, p_g [psf]:	60.0	(Section 7.2)
Terrain Category:	C	(Table 7-2)
Exposure of Roof:	Fully Exposed	(Table 7-2)
Exposure Factor, C_e :	0.9	(Table 7-2)
Thermal Factor, C_t :	1.2	(Table 7-3)
Risk Category:	I	(Table 1.5-1)
Importance Factor, I_s :	0.8	(Table 1.5-2)
Flat Roof Snow Load, p_f [psf]:	36	(Equation 7.3-1)
Minimum Roof Snow Load, p_m [psf]:	0	(Section 7.3.4)
Unobstructed Slippery Surface?	Yes	(Section 7.4)
Slope Factor Figure:	Figure 7-2c	(Section 7.4)
Roof Slope Factor, C_s :	0.636	(Figure 7-2)
Sloped Roof Snow Load, p_s [psf]:	23	(Equation 7.4-1)
Design Snow Load, S [psf]:	23	
Tributary Transverse Length [ft]:	5.6	
Tributary Longitudinal Length [ft]:	6	
Tributary Area per Column [ft ²]:	33.7	
Snow Load per Column (1.0 S) [lb]:	779.3	



PROJECT: A3 – Sunmodo Sunturf GM

SUBJECT: Wind Pressure

Design Wind Load:

ASCE 7 Standard:	10	
Basic Wind Speed, V [mph]:	135	
Risk Category:	I	
Exposure Category	C	(Section 26.7.3)
Velocity Pressure Exposure Coefficient, K_h :	0.85	(Table 27.3-1)
Topographic Factor, K_{ht} :	1.0	(Section 26.8.2)
Wind Directionality Factor, K_d :	0.85	(Table 26.6-1)
Internal Pressure Coefficient, GC_{pi} :	0.00	(Table 26.11-1)
Velocity Pressure, q_h [psf]:	33.7	(Equation 27.3-1)
Gust Effect Factor, G:	0.85	(Section 26.9.1)
Panel Slope [degrees]:	35.0	

Net Pressure Coefficients (C_N) per: (Figure 27.4-4)

Clear Wind Flow	C_{NW}	C_{NL}
Case 1 ($\gamma = 0^\circ$, Load Case A)	-1.80	-1.80
Case 2 ($\gamma = 0^\circ$, Load Case B)	-2.43	-0.57
Case 3 ($\gamma = 180^\circ$, Load Case A)	2.10	2.17
Case 4 ($\gamma = 180^\circ$, Load Case B)	2.67	1.07

Design Wind Pressures (p) [psf] per: (Equation 27.4-3)

Clear Wind Flow	$q_h GC_{NW}$	$q_h GC_{NL}$
Case 1 ($\gamma = 0^\circ$, Load Case A)	-51.6	-51.6
Case 2 ($\gamma = 0^\circ$, Load Case B)	-69.7	-16.2
Case 3 ($\gamma = 180^\circ$, Load Case A)	60.2	62.1
Case 4 ($\gamma = 180^\circ$, Load Case B)	76.4	30.6

Wind Pressure on Each Side of Panels [psf]

Clear Wind Flow	Short Col. Pressure	Long Col. Pressure
Case 1 ($\gamma = 0^\circ$, Load Case A)	-51.6	-51.6
Case 2 ($\gamma = 0^\circ$, Load Case B)	-16.2	-69.7
Case 3 ($\gamma = 180^\circ$, Load Case A)	60.2	62.1
Case 4 ($\gamma = 180^\circ$, Load Case B)	76.4	30.6



JOB NO.: U2716-093-191

PROJECT: A3 – Sunmodo Sunturf GM

SUBJECT: Open Building Wind Loads

Design Wind Load Per ASCE 7-10

$$p = q_h G C_n$$

Velocity Pressure Exposure Coefficient, K_{zt} :	0.85	(Table 27.3-1)
Topographic Factor, K_{ht} :	1.0	(Section 26.8.2)
Wind Directionality Factor, K_d :	0.85	(Table 26.6-1)
Ultimate Wind Speed, V [mph]:	135	

Velocity Pressure, q_h [psf]:	33.7	(Equation 27.3-1)
Gust Effect Factor, G :	0.85	(Section 26.9.1)

$\gamma = 90^\circ$ or 270°

Force Coefficient, C_N :

Horizontal Distance from Winward Edge	Roof angle		
	Load Case	Obstructed Wind Flow	
		CN	
$\leq h$	35	A	-0.8
		B	0.8
$> h, \leq 2h$	35	A	-0.6
		B	0.5
$> 2h$	35	A	-0.3
		B	0.3

Design Wind Pressure, p [psf]:

Horizontal Distance from Winward Edge	Roof angle		
	Load Case	Obstructed Wind Flow	
$\leq h$	35	A	-22.9
		B	22.9
$> h, \leq 2h$	35	A	-17.2
		B	14.3
$> 2h$	35	A	-8.6
		B	8.6



JOB NO.: U2716-093-191

DESIGNED: STB

Foundation Option 1: Drilled Concrete Pier



PROJECT: A3 - Sunturf Ground Mount

DRILLED CONCRETE PIER DESIGN

Column Reactions:

Max. Shear, V [k]:	1.8	Max. Down, P _d [k]:	3.2
Max. Moment, M [k-ft]:	0.0	Max. Uplift, P _u [k]:	2.7

Pier Properties:

Pier Shape:	Round	Volume of Concrete [ft ³]:	11
Pier Diameter, b [ft]:	1.5	Volume of Concrete [yd ³]:	0.4
Top of Pier Elevation [ft]:	0.00	Weight of Concrete [k]:	1.6
Pier Depth, d [ft]:	6.0		

Soil Properties:

Allow. Bearing Pressure [psf]:	1,500	<u>Optional Parameters for Uplift:</u>	
1/3 increase for short term loads?	No		
Lateral Bearing, S [pcf]:	150	Skin Friction* [psf]:	250
Max. Lateral Bearing (opt'l) [psf]:		Top Length to Ignore [ft]:	0
Top Depth to Ignore [ft]:	0	1/3 increase for short term loads?	No
1/3 increase for short term loads?	No	Combine w/ Bearing:	No
1/2" deflection at t/o pier allowed:	Yes		

*per IBC Section 1810.3.3.1.4

Check Bearing:

Bearing Capacity [k]:	7.1
-----------------------	-----

Bearing capacity OK.

Check Uplift:

Uplift Capacity [k]:	8.5
----------------------	-----

Uplift capacity OK.

Check Lateral Bearing:

Top of Pier Constrained?:	No	IBC Section 1807.3.2.1
Applied Lateral Force, P [lb]:	1,806	
Point of Application, h [ft]:	0.0	
S _{max} [psf]:		
S [psf]:	600	
A = 2.34*P/(S _b):	4.70	
Required Pier Depth, d _{reqd} [ft]:	4.70	IBC Eq. 18-1

Result: **Lateral bearing capacity OK.**

Foundation Option 2: Helical Pier

The ground screws and helical piers must be tested to 1.5 times uplift and 2.0 times lateral reactions found in the table below.

Load (ASD)	Value (lbs)	Factor of Safety	Test Value (lbs)
UPLIFT	2651	1.5	3977
LATERAL	1806	2	3612

Foundation Option 3: Ground Screw

The ground screws and helical piers must be tested to 1.5 times uplift and 2.0 times lateral reactions found in the table below.

Load (ASD)	Value (lbs)	Factor of Safety	Test Value (lbs)
UPLIFT	2651	1.5	3977
LATERAL	1806	2	3612



JOB NO.: U2716-093-191

DESIGNED: STB

Foundation Option 4: Ballasted Block

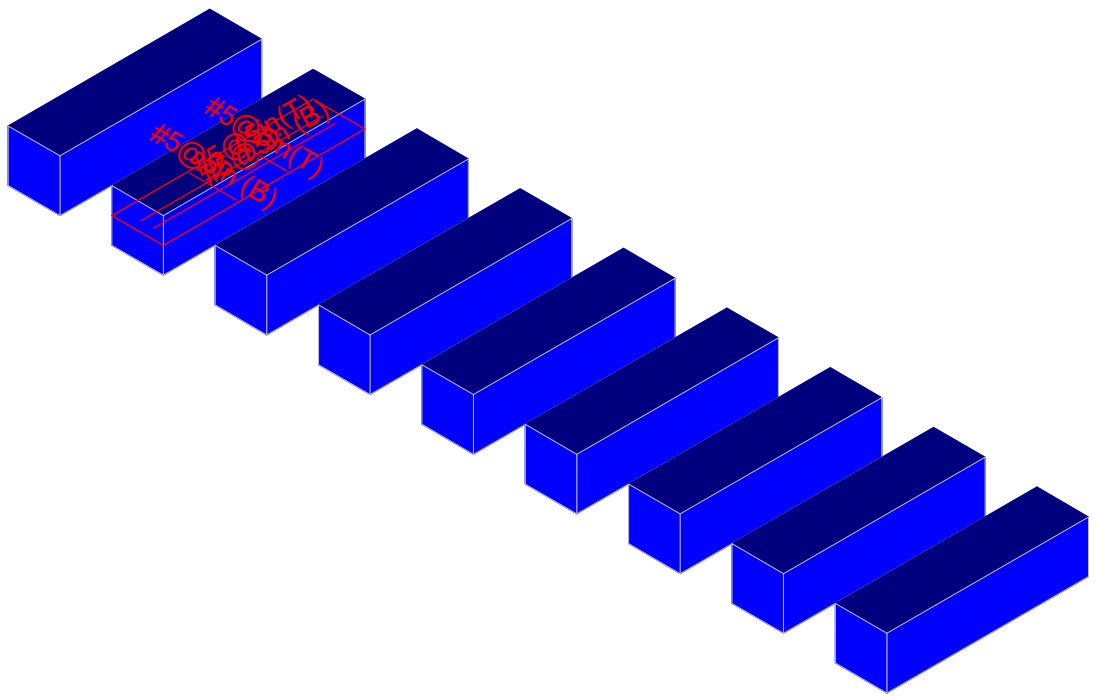

Results for LC 1, 1.0 D

Vector Structural Engineeri..	Ground Mount	SK - 2
STB		Apr 12, 2021 at 3:08 PM
U2716.091.181		Sunmodo Sunturf A3 v7 85x45.r3d

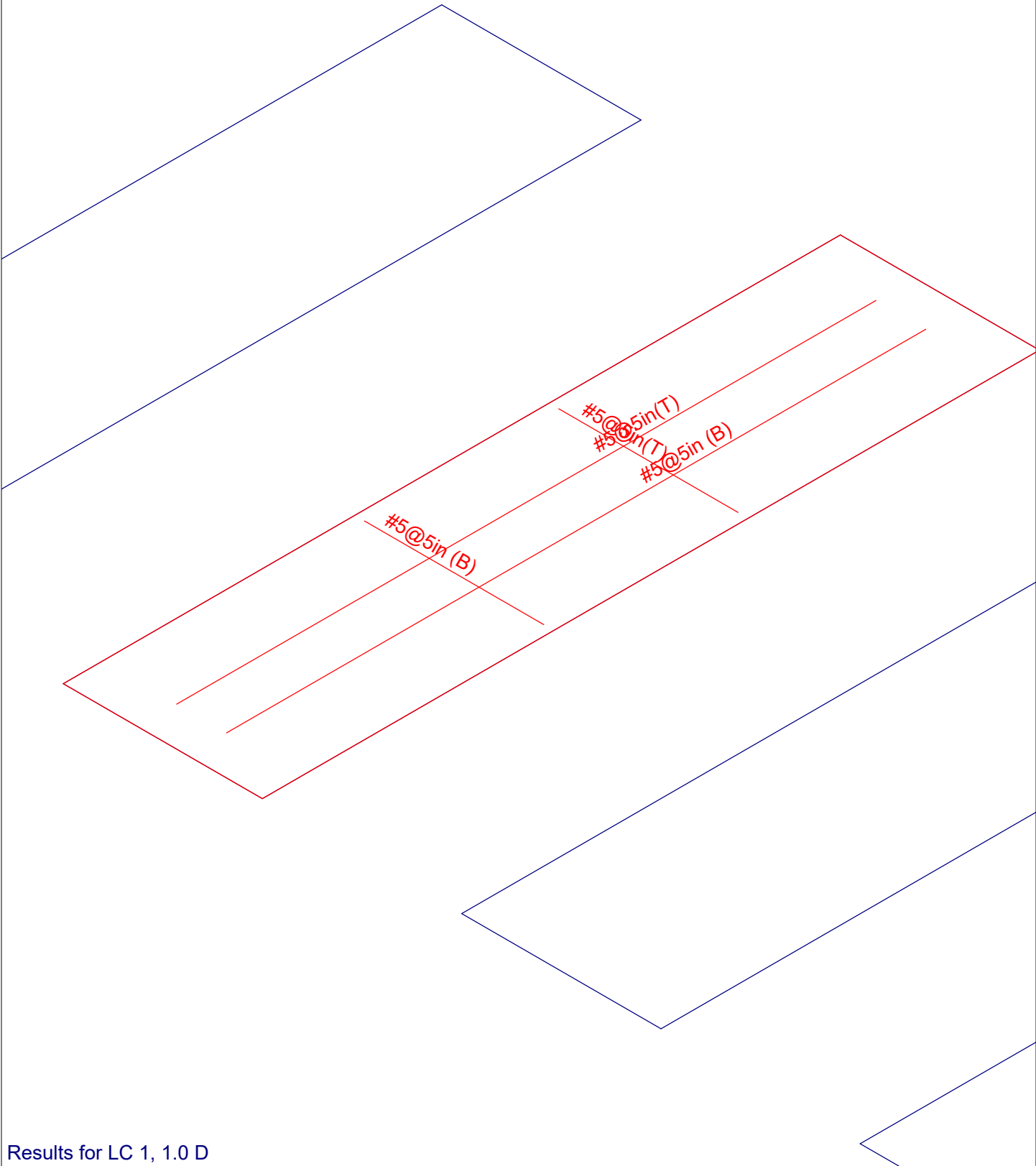

Results for LC 1, 1.0 D

Vector Structural Engineeri..	Ground Mount	SK - 1
STB		Apr 12, 2021 at 3:08 PM
U2716.091.181		Sunmodo Sunturf A3 v7 85x45.r3d

(Global) Model Settings

Display Sections for Member Calcs	5
Max Internal Sections for Member Calcs	100
Mesh Size (in)	12
Max Iterations	10
Merge Tolerance (in)	.12
Solver	Sparse Accelerated
Coefficient of Friction	.3
No. of Shear Regions	4
Shear Region Spacing Increment (in)	4
Min 1 Bar Dia Spacing for Beams?	No
Optimize footings for OTM / Sliding?	Yes
Parame Beta Factor	.65
Pile Safety Factor	3
Concrete Stress Block	0
Concrete Rebar Set	Rectangular
Concrete Code	ASTM A615
HR Steel Pile Code	ACI 318-14
Wood Pile Code	AISC 14th (360-10): ASD AWC NDS-15: ASD

Concrete Properties

	Label	E [ksi]	G [ksi]	Nu	Therm (/...	Density[lb/ft^3]	fc[psi]	Lambda	Flex Stee...	Shear St...
1	Conc3000NW	3156	1372	.15	.6	145	3000	1	60000	60000
2	Conc3500NW	3409	1482	.15	.6	145	3500	1	60000	60000
3	Conc4000NW	3644	1584	.15	.6	145	4000	1	60000	60000
4	Conc3000LW	2085	907	.15	.6	109.999	3000	.75	60000	60000
5	Conc3500LW	2252	979	.15	.6	109.999	3500	.75	60000	60000
6	Conc4000LW	2408	1047	.15	.6	109.999	4000	.75	60000	60000
7	Conc2500NW	3156	1372	.15	.6	145	2500	1	60000	60000

General Design Parameters

	Label	Max Bending Chk	Max Shear Chk	Top Cover[in]	Bottom Cover[in]
1	Typical	1	1	3	3

Slab Rebar Parameters

	Label	Top Bar	Bottom Bar	Max Top Bar Sp...	Min Top Bar Sp...	Max Bot Bar Sp...	Min Bot Bar Sp...	Spacing Incr...	Rebar Options
1	Typical	#5	#5	5	5	5	5	1	Optimize

Soil Definitions

	Label	Subgrade Modulus[lb/ft^3]	Allowable Bearing[psf]	Depth Properties	Default?
1	Default	1e+5	1500	None	Yes

Point Loads and Moments (Cat 1 : DL)

	Label	Direction	Magnitude[lb,lb-ft]
1	R3D_N1	X	-4.418
2	R3D_N1	Y	146.428
3	R3D_N2	X	-3.936
4	R3D_N2	Y	118.264
5	R3D_N132	Y	179.984
6	R3D_N133	Y	161.334
7	R3D_N109	Y	190.932
8	R3D_N110A	X	1.274

Point Loads and Moments (Cat 1 : DL) (Continued)

	Label	Direction	Magnitude[lb,lb-ft]
9	R3D_N110A	Y	172.925
10	R3D_N121	Y	179.937
11	R3D_N122	Y	161.721
12	R3D_N133B	Y	183.222
13	R3D_N134B	Y	164.134
14	R3D_N151	Y	183
15	R3D_N152	Y	163.945
16	R3D_N157A	Y	180.078
17	R3D_N158A	Y	161.84
18	R3D_N157_1	X	4.424
19	R3D_N157_1	Y	146.187
20	R3D_N158_1	X	3.915
21	R3D_N158_1	Y	118.019
22	R3D_N149	Y	191.083
23	R3D_N150	X	-1.312
24	R3D_N150	Y	173.101

Point Loads and Moments (Cat 6 : RLL)

	Label	Direction	Magnitude[lb,lb-ft]
1	R3D_N1	X	-20.664
2	R3D_N1	Y	515.55
3	R3D_N2	X	-20.031
4	R3D_N2	Y	475.891
5	R3D_N132	Y	714.556
6	R3D_N133	Y	688.759
7	R3D_N109	X	1.83
8	R3D_N109	Y	756.671
9	R3D_N110A	X	6.618
10	R3D_N110A	Y	748.383
11	R3D_N121	Y	716.698
12	R3D_N122	X	1.023
13	R3D_N122	Y	690.987
14	R3D_N133B	Y	731.219
15	R3D_N134B	X	-1.342
16	R3D_N134B	Y	703.149
17	R3D_N151	Y	730.081
18	R3D_N152	X	1.384
19	R3D_N152	Y	702.256
20	R3D_N157A	Y	717.456
21	R3D_N158A	Y	691.568
22	R3D_N157_1	X	20.705
23	R3D_N157_1	Y	514.859
24	R3D_N158_1	X	19.907
25	R3D_N158_1	Y	475.089
26	R3D_N149	X	-1.911
27	R3D_N149	Y	757.239
28	R3D_N150	X	-6.788
29	R3D_N150	Y	749.229

Point Loads and Moments (Cat 16 : OL1)

	Label	Direction	Magnitude[lb,lb-ft]
1	R3D_N1	X	56.493
2	R3D_N1	Y	-2721.545
3	R3D_N1	Z	1566.346
4	R3D_N2	X	35.136
5	R3D_N2	Y	477.959

Point Loads and Moments (Cat 16 : OL1) (Continued)

	Label	Direction	Magnitude[lb,lb-ft]
6	R3D_N2	Z	-84.105
7	R3D_N132	Y	-3844.53
8	R3D_N132	Z	2272.254
9	R3D_N133	Y	696.801
10	R3D_N133	Z	-104.534
11	R3D_N109	X	-5.181
12	R3D_N109	Y	-4192.119
13	R3D_N109	Z	2539.373
14	R3D_N110A	X	-8.817
15	R3D_N110A	Y	833.256
16	R3D_N110A	Z	-102.403
17	R3D_N121	X	-1.783
18	R3D_N121	Y	-3919.982
19	R3D_N121	Z	2315.433
20	R3D_N122	X	2.159
21	R3D_N122	Y	761.643
22	R3D_N122	Z	-104.781
23	R3D_N133B	Y	-4019.695
24	R3D_N133B	Z	2381.272
25	R3D_N134B	X	4.26
26	R3D_N134B	Y	803.285
27	R3D_N134B	Z	-105.941
28	R3D_N151	Y	-4007.543
29	R3D_N151	Z	2373.728
30	R3D_N152	X	-4.468
31	R3D_N152	Y	795.616
32	R3D_N152	Z	-105.83
33	R3D_N157A	X	1.544
34	R3D_N157A	Y	-3932.628
35	R3D_N157A	Z	2323.938
36	R3D_N158A	X	-2.771
37	R3D_N158A	Y	771.247
38	R3D_N158A	Z	-104.909
39	R3D_N157_1	X	-56.637
40	R3D_N157_1	Y	-2720.093
41	R3D_N157_1	Z	1565.784
42	R3D_N158_1	X	-34.708
43	R3D_N158_1	Y	479.37
44	R3D_N158_1	Z	-84.073
45	R3D_N149	X	5.402
46	R3D_N149	Y	-4189.258
47	R3D_N149	Z	2536.41
48	R3D_N150	X	9.085
49	R3D_N150	Y	827.816
50	R3D_N150	Z	-102.378

Point Loads and Moments (Cat 17 : OL2)

	Label	Direction	Magnitude[lb,lb-ft]
1	R3D_N1	X	72.281
2	R3D_N1	Y	-3036.737
3	R3D_N1	Z	1322.731
4	R3D_N2	X	5.008
5	R3D_N2	Y	1118.444
6	R3D_N2	Z	-70.924
7	R3D_N132	Y	-4258.487
8	R3D_N132	Z	1893.38

Point Loads and Moments (Cat 17 : OL2) (Continued)

	Label	Direction	Magnitude[lb.-lb-ft]
9	R3D_N133	Y	1607.733
10	R3D_N133	Z	-87.691
11	R3D_N109	X	-6.696
12	R3D_N109	Y	-4641.852
13	R3D_N109	Z	2128.153
14	R3D_N110A	X	2.467
15	R3D_N110A	Y	1842.766
16	R3D_N110A	Z	-85.99
17	R3D_N121	X	-2.139
18	R3D_N121	Y	-4351.137
19	R3D_N121	Z	1952.293
20	R3D_N122	X	4.433
21	R3D_N122	Y	1692.773
22	R3D_N122	Z	-88.283
23	R3D_N133B	X	1.047
24	R3D_N133B	Y	-4473.282
25	R3D_N133B	Z	2016.906
26	R3D_N134B	X	2.725
27	R3D_N134B	Y	1766.862
28	R3D_N134B	Z	-89.355
29	R3D_N151	Y	-4458.6
30	R3D_N151	Z	2008.334
31	R3D_N152	X	-2.894
32	R3D_N152	Y	1755.735
33	R3D_N152	Z	-89.229
34	R3D_N157A	X	1.839
35	R3D_N157A	Y	-4366.578
36	R3D_N157A	Z	1962.232
37	R3D_N158A	X	-4.51
38	R3D_N158A	Y	1705.784
39	R3D_N158A	Z	-88.431
40	R3D_N157_1	X	-72.453
41	R3D_N157_1	Y	-3034.519
42	R3D_N157_1	Z	1322.658
43	R3D_N158_1	X	-4.755
44	R3D_N158_1	Y	1118.427
45	R3D_N158_1	Z	-70.899
46	R3D_N149	X	6.966
47	R3D_N149	Y	-4637.77
48	R3D_N149	Z	2123.991
49	R3D_N150	X	-2.442
50	R3D_N150	Y	1836.872
51	R3D_N150	Z	-85.95

Point Loads and Moments (Cat 18 : OL3)

	Label	Direction	Magnitude[lb.-lb-ft]
1	R3D_N1	X	-67.845
2	R3D_N1	Y	3252.638
3	R3D_N1	Z	-1856.915
4	R3D_N2	X	-40.778
5	R3D_N2	Y	-592.01
6	R3D_N2	Z	99.703
7	R3D_N132	Y	4593.656
8	R3D_N132	Z	-2692.869
9	R3D_N133	Y	-862.262
10	R3D_N133	Z	123.905

Point Loads and Moments (Cat 18 : OL3) (Continued)

	Label	Direction	Magnitude[lb.-ft]
11	R3D_N109	X	6.225
12	R3D_N109	Y	5008.915
13	R3D_N109	Z	-3009.868
14	R3D_N110A	X	10.101
15	R3D_N110A	Y	-1028.285
16	R3D_N110A	Z	121.382
17	R3D_N121	X	2.137
18	R3D_N121	Y	4684.131
19	R3D_N121	Z	-2744.856
20	R3D_N122	X	-2.652
21	R3D_N122	Y	-940.209
22	R3D_N122	Z	124.211
23	R3D_N133B	X	-1.029
24	R3D_N133B	Y	4803.69
25	R3D_N133B	Z	-2823.228
26	R3D_N134B	X	-5.019
27	R3D_N134B	Y	-990.958
28	R3D_N134B	Z	125.59
29	R3D_N151	Y	4789.126
30	R3D_N151	Z	-2814.207
31	R3D_N152	X	5.265
32	R3D_N152	Y	-981.701
33	R3D_N152	Z	125.457
34	R3D_N157A	X	-1.85
35	R3D_N157A	Y	4699.293
36	R3D_N157A	Z	-2755.036
37	R3D_N158A	X	3.362
38	R3D_N158A	Y	-951.768
39	R3D_N158A	Z	124.364
40	R3D_N157_1	X	68.018
41	R3D_N157_1	Y	3250.881
42	R3D_N157_1	Z	-1856.263
43	R3D_N158_1	X	40.275
44	R3D_N158_1	Y	-593.64
45	R3D_N158_1	Z	99.666
46	R3D_N149	X	-6.489
47	R3D_N149	Y	5005.464
48	R3D_N149	Z	-3006.297
49	R3D_N150	X	-10.411
50	R3D_N150	Y	-1021.79
51	R3D_N150	Z	121.352

Point Loads and Moments (Cat 19 : OL4)

	Label	Direction	Magnitude[lb.-ft]
1	R3D_N1	X	-36.95
2	R3D_N1	Y	2161.364
3	R3D_N1	Z	-1607.79
4	R3D_N2	X	-57.179
5	R3D_N2	Y	121.336
6	R3D_N2	Z	86.416
7	R3D_N132	Y	3079.991
8	R3D_N132	Z	-2354.178
9	R3D_N133	Y	157.365
10	R3D_N133	Z	107.8
11	R3D_N109	X	3.332
12	R3D_N109	Y	3359.869

Point Loads and Moments (Cat 19 : OL4) (Continued)

	Label	Direction	Magnitude[lb.-ft]
13	R3D_N109	Z	-2620.49
14	R3D_N110A	X	17.537
15	R3D_N110A	Y	119.858
16	R3D_N110A	Z	105.529
17	R3D_N121	X	1.289
18	R3D_N121	Y	3132.669
19	R3D_N121	Z	-2379.282
20	R3D_N122	Y	116.731
21	R3D_N122	Z	107.725
22	R3D_N133B	Y	3202.542
23	R3D_N133B	Z	-2439.146
24	R3D_N134B	X	-5.119
25	R3D_N134B	Y	107.31
26	R3D_N134B	Z	108.837
27	R3D_N151	Y	3193.852
28	R3D_N151	Z	-2433.286
29	R3D_N152	X	5.338
30	R3D_N152	Y	111.199
31	R3D_N152	Z	108.751
32	R3D_N157A	X	-1.127
33	R3D_N157A	Y	3141.575
34	R3D_N157A	Z	-2385.651
35	R3D_N158A	Y	111.069
36	R3D_N158A	Z	107.822
37	R3D_N157_1	X	37.055
38	R3D_N157_1	Y	2160.722
39	R3D_N157_1	Z	-1606.87
40	R3D_N158_1	X	56.647
41	R3D_N158_1	Y	118.852
42	R3D_N158_1	Z	86.382
43	R3D_N149	X	-3.486
44	R3D_N149	Y	3358.358
45	R3D_N149	Z	-2618.87
46	R3D_N150	X	-17.983
47	R3D_N150	Y	124.328
48	R3D_N150	Z	105.519

Point Loads and Moments (Cat 20 : OL5)

	Label	Direction	Magnitude[lb.-ft]
1	R3D_N1	X	-21.105
2	R3D_N1	Y	1222.482
3	R3D_N1	Z	-708.58
4	R3D_N2	X	-18.643
5	R3D_N2	Y	-211.46
6	R3D_N2	Z	35.196
7	R3D_N132	Y	612.971
8	R3D_N132	Z	-368.126
9	R3D_N133	Y	-120.242
10	R3D_N133	Z	20.232
11	R3D_N109	X	3.656
12	R3D_N109	Y	1694.322
13	R3D_N109	Z	-1018.314
14	R3D_N110A	X	7.501
15	R3D_N110A	Y	-348.041
16	R3D_N110A	Z	39.22
17	R3D_N121	Y	1313.627

Point Loads and Moments (Cat 20 : OL5) (Continued)

	Label	Direction	Magnitude[lb,lb-ft]
18	R3D_N121	Z	-770.572
19	R3D_N122	Y	-266.099
20	R3D_N122	Z	34.014
21	R3D_N133B	X	1.967
22	R3D_N133B	Y	1018.363
23	R3D_N133B	Z	-599.766
24	R3D_N134B	X	4.523
25	R3D_N134B	Y	-193.318
26	R3D_N134B	Z	27.072
27	R3D_N151	Y	670.563
28	R3D_N151	Z	-396.163
29	R3D_N152	X	1.62
30	R3D_N152	Y	-128.026
31	R3D_N152	Z	18.468
32	R3D_N157A	Y	655.654
33	R3D_N157A	Z	-387.193
34	R3D_N158A	Y	-128.952
35	R3D_N158A	Z	17.734
36	R3D_N157_1	X	13.906
37	R3D_N157_1	Y	464.025
38	R3D_N157_1	Z	-260.034
39	R3D_N158_1	X	6.518
40	R3D_N158_1	Y	-80.198
41	R3D_N158_1	Z	14.024
42	R3D_N149	Y	688.976
43	R3D_N149	Z	-424.06
44	R3D_N150	Y	-138.406
45	R3D_N150	Z	17.159

Point Loads and Moments (Cat 21 : OL6)

	Label	Direction	Magnitude[lb,lb-ft]
1	R3D_N1	X	21.623
2	R3D_N1	Y	-1233.255
3	R3D_N1	Z	713.781
4	R3D_N2	X	19.012
5	R3D_N2	Y	215.411
6	R3D_N2	Z	-34.363
7	R3D_N132	Y	-619.526
8	R3D_N132	Z	370.514
9	R3D_N133	Y	119.131
10	R3D_N133	Z	-19.399
11	R3D_N109	X	-4.147
12	R3D_N109	Y	-1615.084
13	R3D_N109	Z	967.745
14	R3D_N110A	X	-8.906
15	R3D_N110A	Y	330.107
16	R3D_N110A	Z	-36.813
17	R3D_N121	Y	-1073.761
18	R3D_N121	Z	633.697
19	R3D_N122	X	1.279
20	R3D_N122	Y	225.282
21	R3D_N122	Z	-29.968
22	R3D_N133B	X	-1.592
23	R3D_N133B	Y	-904.868
24	R3D_N133B	Z	532.332
25	R3D_N134B	X	-3.534

Load Combinations (Continued)

Label	Solve	Service A...	SF	Cat..Fa...	Cat..Fa...	Cat..Fa...	Cat..Fa...	Cat..Fa...	Cat..Fa...	Cat..Fa...	Cat..Fa...	Cat..Fa...	Cat..Fa...	Cat..Fa...	Cat..Fa...	Cat..Fa...	Cat..Fa...	Cat..Fa...
20	0.9D+0...	Yes	Yes		DL .9	RLL		OL6	.6									
21																		
22	1.4D	Yes			DL 1.4													
23	1.2D+1.6SL	Yes			DL 1.2	RLL 1.6												
24	1.2D+1.6S...	Yes			DL 1.2	RLL 1.6	OL1	.5										
25	1.2D+1.6S...	Yes			DL 1.2	RLL 1.6	OL2	.5										
26	1.2D+1.6S...	Yes			DL 1.2	RLL 1.6	OL3	.5										
27	1.2D+1.6S...	Yes			DL 1.2	RLL 1.6	OL4	.5										
28	1.2D+1.6S...	Yes			DL 1.2	RLL 1.6	OL5	.5										
29	1.2D+1.6S...	Yes			DL 1.2	RLL 1.6	OL6	.5										
30	1.2D+1.0...	Yes			DL 1.2		OL1	1										
31	1.2D-1.0Wx	Yes			DL 1.2		OL2	1										
32	1.2D+1.0...	Yes			DL 1.2		OL3	1										
33	1.2D-1.0Wz	Yes			DL 1.2		OL4	1										
34	1.2D+1.0...	Yes			DL 1.2		OL5	1										
35	1.2D-1.0...	Yes			DL 1.2		OL6	1										
36	1.0D+1.0...	Yes			DL 1		OL1	1										
37	1.0D-1.0Wx	Yes			DL 1		OL2	1										
38	1.0D+1.0...	Yes			DL 1		OL3	1										
39	1.0D-1.0Wz	Yes			DL 1		OL4	1										
40	1.0D+1.0...	Yes			DL 1		OL5	1										
41	1.0D-1.0...	Yes			DL 1		OL6	1										

Design Strips

	Label	Rebar Angle from PI...	No. of Design Cuts	Design Rule
1	DS1	0	50	Typical
2	DS2	90	50	Typical

Load Categories

	Category	Point Loads	Line Loads	Area Loads
1	DL	24		
2	RLL	29		
3	OL1	50		
4	OL2	51		
5	OL3	51		
6	OL4	48		
7	OL5	45		
8	OL6	47		

Strip Reinforcing

Label	UC Top	LC	Top Bars	Governing ...	UC Bot	LC	Bot B...	Gover...	UC Shear	LC	Governing De...	
1	DS1	.011	26	#5@5in	DS1-X25	.02	37	#5@5in	DS1-...	.037	37	DS1-X15
2	DS2	.001	36	#5@5in	DS2-X26	.002	26	#5@5in	DS2-...	.005	26	DS2-X43

Slab Overturning Safety Factors

LC	Slab	Angle[deg]	Mo-xx[lb-ft]	Ms-xx[lb-ft]	Mo-zz[lb-ft]	Ms-zz[lb-ft]	Ms-xx/Mo-xx	Ms-zz/Mo-zz
1	S1	0	0	44275.823	0	11396.69	9.999+	9.999+
2	S2	0	0	44799.78	0	11496.578	9.999+	9.999+
3	S3	0	0	44689.885	0	11472.013	9.999+	9.999+
4	S4	0	0	44714.772	0	11479.135	9.999+	9.999+
5	S5	0	0	44686.663	0	11471.589	9.999+	9.999+
6	S6	0	0	44712.87	0	11478.622	9.999+	9.999+
7	S7	0	0	44691.083	0	11472.338	9.999+	9.999+
8	S8	0	0	44801.474	0	11503.45	9.999+	9.999+
9	S9	0	0	44273.42	0	11354.351	9.999+	9.999+



Company : Vector Structural Engineering
 Designer : STB
 Job Number : U2716.091.181
 Model Name : Ground Mount

Apr 12, 2021
 3:08 PM
 Checked By: JSP

Slab Overturning Safety Factors (Continued)

	LC	Slab	Angle[deg]	Mo-xx[lb-ft]	Ms-xx[lb-ft]	Mo-zz[lb-ft]	Ms-zz[lb-ft]	Ms-xx/Mo-xx	Ms-zz/Mo-zz
10	2	S1	0	0	49008.29	0	12737.73	9.999+	9.999+
11	2	S2	0	0	52169.926	0	13356.777	9.999+	9.999+
12	2	S3	0	0	51518.864	0	13229.061	9.999+	9.999+
13	2	S4	0	0	51666.495	0	13275.451	9.999+	9.999+
14	2	S5	0	0	51493.849	0	13225.732	9.999+	9.999+
15	2	S6	0	0	51655.485	0	13265.583	9.999+	9.999+
16	2	S7	0	0	51526.018	0	13233.619	9.999+	9.999+
17	2	S8	0	0	52179.564	0	13408.282	9.999+	9.999+
18	2	S9	0	0	48998.154	0	12490.257	9.999+	9.999+
19	3	S1	0	15608.722	44455.612	1820.132	11396.69	2.848	6.261
20	3	S2	0	24200.755	44898.521	2540.146	11502.947	1.855	4.528
21	3	S3	0	22540.693	44791.969	2369.317	11472.013	1.987	4.842
22	3	S4	0	23110.034	44822.633	2418.697	11479.135	1.94	4.746
23	3	S5	0	22143.897	44791.882	2360.797	11471.589	2.023	4.859
24	3	S6	0	23043.267	44820.532	2415.646	11478.622	1.945	4.752
25	3	S7	0	22609.922	44793.307	2372.876	11472.338	1.981	4.835
26	3	S8	0	24185.98	44900.007	2542.811	11503.45	1.856	4.524
27	3	S9	0	15599.536	44453.277	1817.559	11396.045	2.85	6.27
28	4	S1	0	16374.424	44455.612	1554.653	11396.69	2.715	7.331
29	4	S2	0	25122.558	44898.521	2105.658	11502.947	1.787	5.463
30	4	S3	0	23499.711	44791.969	1997.215	11472.013	1.906	5.744
31	4	S4	0	24156.289	44822.633	2035.474	11479.135	1.856	5.64
32	4	S5	0	23008.128	44791.882	1988.066	11471.589	1.947	5.77
33	4	S6	0	24077.821	44820.532	2031.491	11478.622	1.861	5.65
34	4	S7	0	23582.616	44793.307	1999.602	11472.338	1.899	5.737
35	4	S8	0	25100.183	44900.007	2107.459	11503.45	1.789	5.458
36	4	S9	0	16363.164	44453.277	1552.881	11396.045	2.717	7.339
37	5	S1	0	3052.965	44275.823	0	13555.096	9.999+	9.999+
38	5	S2	0	5569.859	44799.78	0	14457.562	8.043	9.999+
39	5	S3	0	4978.736	44689.885	0	14280.728	8.976	9.999+
40	5	S4	0	5257.398	44714.772	0	14347.755	8.505	9.999+
41	5	S5	0	4576.067	44686.663	0	14270.134	9.765	9.999+
42	5	S6	0	5208.51	44712.87	0	14326.293	8.585	9.999+
43	5	S7	0	5040.601	44691.083	0	14280.713	8.866	9.999+
44	5	S8	0	5534.187	44801.474	0	14516.555	8.095	9.999+
45	5	S9	0	3061.764	44273.42	0	13184.843	9.999+	9.999+
46	6	S1	0	0	44341.662	0	13249.909	9.999+	9.999+
47	6	S2	0	473.279	44799.78	0	14075.07	9.999+	9.999+
48	6	S3	0	305.878	44689.885	0	13907.13	9.999+	9.999+
49	6	S4	0	386.158	44714.772	0	13969.201	9.999+	9.999+
50	6	S5	0	103.022	44686.663	0	13899.606	9.999+	9.999+
51	6	S6	0	364.617	44712.87	0	13949.403	9.999+	9.999+
52	6	S7	0	337.041	44691.083	0	13913.512	9.999+	9.999+
53	6	S8	0	449.274	44801.474	0	14147.67	9.999+	9.999+
54	6	S9	0	0	44327.405	0	12923.478	9.999+	9.999+
55	7	S1	0	1110.54	44275.823	0	12214.579	9.999+	9.999+
56	7	S2	0	1888.198	44799.78	0	12489.554	9.999+	9.999+
57	7	S3	0	1411.041	44689.885	0	12257.659	9.999+	9.999+
58	7	S4	0	1030.277	44714.772	0	12088.183	9.999+	9.999+
59	7	S5	0	644.698	44686.663	0	11841.135	9.999+	9.999+
60	7	S6	0	683.028	44712.87	0	11883.094	9.999+	9.999+
61	7	S7	0	687.323	44691.083	0	11867.364	9.999+	9.999+
62	7	S8	0	765.043	44801.474	0	11916.378	9.999+	9.999+
63	7	S9	0	406.803	44273.42	0	11611.585	9.999+	9.999+
64	8	S1	0	7085.521	44455.612	824.336	11396.69	6.274	9.999+
65	8	S2	0	9305.009	44898.521	983.313	11502.947	4.825	9.999+
66	8	S3	0	6159.136	44791.969	638.278	11472.013	7.272	9.999+



Company : Vector Structural Engineering
 Designer : STB
 Job Number : U2716.091.181
 Model Name : Ground Mount

Apr 12, 2021
 3:08 PM
 Checked By: JSP

Slab Overturning Safety Factors (Continued)

	LC	Slab	Angle[deg]	Mo-xx[lb-ft]	Ms-xx[lb-ft]	Mo-zz[lb-ft]	Ms-zz[lb-ft]	Ms-xx/Mo-xx	Ms-zz/Mo-zz
67	8	S4	0	5204.367	44822.633	559.149	11479.135	8.613	9.999+
68	8	S5	0	3565.937	44791.882	375.296	11471.589	9.999+	9.999+
69	8	S6	0	3857.149	44820.532	408.037	11478.622	9.999+	9.999+
70	8	S7	0	3768.999	44793.307	396.878	11472.338	9.999+	9.999+
71	8	S8	0	3981.966	44900.007	412.284	11496.89	9.999+	9.999+
72	8	S9	0	2656.081	44453.277	319.604	11396.045	9.999+	9.999+
73	9	S1	0	11706.542	48156.185	1365.099	12402.47	4.114	9.085
74	9	S2	0	18150.566	50376.637	1905.109	12929.774	2.775	6.787
75	9	S3	0	16905.519	49963.944	1776.988	12789.799	2.955	7.197
76	9	S4	0	17332.526	50097.678	1814.023	12826.372	2.89	7.071
77	9	S5	0	16607.923	49948.249	1770.598	12787.196	3.007	7.222
78	9	S6	0	17282.45	50087.556	1811.735	12824.033	2.898	7.078
79	9	S7	0	16957.442	49970.617	1779.657	12793.299	2.947	7.189
80	9	S8	0	18139.485	50382.505	1907.108	12932.074	2.778	6.781
81	9	S9	0	11699.652	48148.738	1363.17	12400.269	4.115	9.097
82	10	S1	0	12280.818	48156.185	1165.99	12402.47	3.921	9.999+
83	10	S2	0	18841.918	50376.637	1579.244	12929.774	2.674	8.187
84	10	S3	0	17624.783	49963.944	1497.911	12789.799	2.835	8.538
85	10	S4	0	18117.217	50097.678	1526.605	12826.372	2.765	8.402
86	10	S5	0	17256.096	49948.249	1491.049	12787.196	2.895	8.576
87	10	S6	0	18058.366	50087.556	1523.618	12824.033	2.774	8.417
88	10	S7	0	17686.962	49970.617	1499.702	12793.299	2.825	8.531
89	10	S8	0	18825.137	50382.505	1580.594	12932.074	2.676	8.182
90	10	S9	0	12272.373	48148.738	1164.66	12400.269	3.923	9.999+
91	11	S1	0	2289.724	47825.173	0	14021.274	9.999+	9.999+
92	11	S2	0	4177.394	50327.39	0	15112.465	9.999+	9.999+
93	11	S3	0	3734.052	49811.619	0	14896.335	9.999+	9.999+
94	11	S4	0	3943.049	49928.564	0	14977.838	9.999+	9.999+
95	11	S5	0	3432.05	49792.052	0	14886.105	9.999+	9.999+
96	11	S6	0	3906.383	49919.832	0	14954.596	9.999+	9.999+
97	11	S7	0	3780.45	49817.284	0	14899.58	9.999+	9.999+
98	11	S8	0	4150.64	50335.042	0	15191.903	9.999+	9.999+
99	11	S9	0	2296.323	47816.97	0	13579.149	9.999+	9.999+
100	12	S1	0	0	47874.553	0	13792.383	9.999+	9.999+
101	12	S2	0	354.96	50327.39	0	14825.596	9.999+	9.999+
102	12	S3	0	229.409	49811.619	0	14616.136	9.999+	9.999+
103	12	S4	0	289.619	49928.564	0	14693.922	9.999+	9.999+
104	12	S5	0	77.266	49792.052	0	14608.209	9.999+	9.999+
105	12	S6	0	273.462	49919.832	0	14671.929	9.999+	9.999+
106	12	S7	0	252.781	49817.284	0	14624.179	9.999+	9.999+
107	12	S8	0	336.956	50335.042	0	14915.239	9.999+	9.999+
108	12	S9	0	0	47857.46	0	13383.126	9.999+	9.999+
109	13	S1	0	832.905	47825.173	0	13015.886	9.999+	9.999+
110	13	S2	0	1416.149	50327.39	0	13636.459	9.999+	9.999+
111	13	S3	0	1058.281	49811.619	0	13379.034	9.999+	9.999+
112	13	S4	0	772.707	49928.564	0	13283.158	9.999+	9.999+
113	13	S5	0	483.524	49792.052	0	13064.356	9.999+	9.999+
114	13	S6	0	512.271	49919.832	0	13122.197	9.999+	9.999+
115	13	S7	0	515.493	49817.284	0	13089.569	9.999+	9.999+
116	13	S8	0	573.782	50335.042	0	13241.77	9.999+	9.999+
117	13	S9	0	305.102	47816.97	0	12399.206	9.999+	9.999+
118	14	S1	0	5314.141	48156.185	618.252	12402.47	9.062	9.999+
119	14	S2	0	6978.757	50376.637	737.485	12929.774	7.219	9.999+
120	14	S3	0	4619.352	49963.944	478.709	12789.799	9.999+	9.999+
121	14	S4	0	3903.275	50097.678	419.362	12821.338	9.999+	9.999+
122	14	S5	0	2674.453	49948.249	281.472	12787.196	9.999+	9.999+
123	14	S6	0	2892.862	50087.556	306.028	12824.033	9.999+	9.999+



Company : Vector Structural Engineering
 Designer : STB
 Job Number : U2716.091.181
 Model Name : Ground Mount

Apr 12, 2021
 3:08 PM
 Checked By: JSP

Slab Overturning Safety Factors (Continued)

LC	Slab	Angle[deg]	Mo-xx[lb-ft]	Ms-xx[lb-ft]	Mo-zz[lb-ft]	Ms-zz[lb-ft]	Ms-xx/Mo-xx	Ms-zz/Mo-zz	
124	14	S7	0	2826.749	49970.617	297.659	12793.299	9.999+	9.999+
125	14	S8	0	2986.475	50382.505	309.213	12892.894	9.999+	9.999+
126	14	S9	0	1992.061	48148.738	239.703	12400.269	9.999+	9.999+
127	15	S1	0	15608.722	40010.051	1820.132	10257.021	2.563	5.635
128	15	S2	0	24200.755	40408.669	2540.146	10352.652	1.67	4.076
129	15	S3	0	22540.693	40312.772	2369.317	10324.812	1.788	4.358
130	15	S4	0	23110.034	40340.37	2418.697	10331.221	1.746	4.271
131	15	S5	0	22143.897	40312.694	2360.797	10324.43	1.82	4.373
132	15	S6	0	23043.267	40338.479	2415.646	10330.76	1.751	4.277
133	15	S7	0	22609.922	40313.976	2372.876	10325.104	1.783	4.351
134	15	S8	0	24185.98	40410.006	2542.811	10353.105	1.671	4.072
135	15	S9	0	15599.536	40007.95	1817.559	10256.441	2.565	5.643
136	16	S1	0	16374.424	40010.051	1554.653	10257.021	2.443	6.598
137	16	S2	0	25122.558	40408.669	2105.658	10352.652	1.608	4.917
138	16	S3	0	23499.711	40312.772	1997.215	10324.812	1.715	5.17
139	16	S4	0	24156.289	40340.37	2035.474	10331.221	1.67	5.076
140	16	S5	0	23008.128	40312.694	1988.066	10324.43	1.752	5.193
141	16	S6	0	24077.821	40338.479	2031.491	10330.76	1.675	5.085
142	16	S7	0	23582.616	40313.976	1999.602	10325.104	1.709	5.164
143	16	S8	0	25100.183	40410.006	2107.459	10353.105	1.61	4.913
144	16	S9	0	16363.164	40007.95	1552.881	10256.441	2.445	6.605
145	17	S1	0	3052.965	39848.24	0	12415.427	9.999+	9.999+
146	17	S2	0	5569.859	40319.802	0	13307.904	7.239	9.999+
147	17	S3	0	4978.736	40220.897	0	13133.527	8.079	9.999+
148	17	S4	0	5257.398	40243.295	0	13199.842	7.655	9.999+
149	17	S5	0	4576.067	40217.996	0	13122.975	8.789	9.999+
150	17	S6	0	5208.51	40241.583	0	13178.43	7.726	9.999+
151	17	S7	0	5040.601	40221.975	0	13133.479	7.98	9.999+
152	17	S8	0	5534.187	40321.327	0	13366.21	7.286	9.999+
153	17	S9	0	3061.764	39846.078	0	12049.407	9.999+	9.999+
154	18	S1	0	0	39914.08	0	12110.24	9.999+	9.999+
155	18	S2	0	473.279	40319.802	0	12925.412	9.999+	9.999+
156	18	S3	0	305.878	40220.897	0	12759.928	9.999+	9.999+
157	18	S4	0	386.158	40243.295	0	12821.288	9.999+	9.999+
158	18	S5	0	103.022	40217.996	0	12752.447	9.999+	9.999+
159	18	S6	0	364.617	40241.583	0	12801.541	9.999+	9.999+
160	18	S7	0	337.041	40221.975	0	12766.278	9.999+	9.999+
161	18	S8	0	449.274	40321.327	0	12997.325	9.999+	9.999+
162	18	S9	0	0	39900.063	0	11788.043	9.999+	9.999+
163	19	S1	0	1110.54	39848.24	0	11074.91	9.999+	9.999+
164	19	S2	0	1888.198	40319.802	0	11339.896	9.999+	9.999+
165	19	S3	0	1411.041	40220.897	0	11110.458	9.999+	9.999+
166	19	S4	0	1030.277	40243.295	0	10940.27	9.999+	9.999+
167	19	S5	0	644.698	40217.996	0	10693.976	9.999+	9.999+
168	19	S6	0	683.028	40241.583	0	10735.232	9.999+	9.999+
169	19	S7	0	687.323	40221.975	0	10720.131	9.999+	9.999+
170	19	S8	0	765.043	40321.327	0	10766.033	9.999+	9.999+
171	19	S9	0	406.803	39846.078	0	10476.15	9.999+	9.999+
172	20	S1	0	7085.521	40010.051	824.336	10257.021	5.647	9.999+
173	20	S2	0	9305.009	40408.669	983.313	10352.652	4.343	9.999+
174	20	S3	0	6159.136	40312.772	638.278	10324.812	6.545	9.999+
175	20	S4	0	5204.367	40340.37	559.149	10331.221	7.751	9.999+
176	20	S5	0	3565.937	40312.694	375.296	10324.43	9.999+	9.999+
177	20	S6	0	3857.149	40338.479	408.037	10330.76	9.999+	9.999+
178	20	S7	0	3768.999	40313.976	396.878	10325.104	9.999+	9.999+
179	20	S8	0	3981.966	40410.006	412.284	10347.201	9.999+	9.999+
180	20	S9	0	2656.081	40007.95	319.604	10256.441	9.999+	9.999+



Slab Sliding Safety Factors

	LC	Slab	Angle[deg]	Va-xx[lb]	Vr-xx[lb]	Va-zz[lb]	Vr-zz[lb]	SR-xx	SR-zz
1	1	S1	0	8.354	2730.193	0	2730.193	9.999+	9.999+
2	1	S2	0	1.274	2759.943	0	2759.943	9.999+	9.999+
3	1	S3	0	0	2753.283	0	2753.283	9.999+	9.999+
4	1	S4	0	0	2754.992	0	2754.992	9.999+	9.999+
5	1	S5	0	0	2753.181	0	2753.181	9.999+	9.999+
6	1	S6	0	0	2754.869	0	2754.869	9.999+	9.999+
7	1	S7	0	0	2753.361	0	2753.361	9.999+	9.999+
8	1	S8	0	1.312	2760.041	0	2760.041	9.999+	9.999+
9	1	S9	0	8.339	2730.048	0	2730.048	9.999+	9.999+
10	2	S1	0	49.049	3027.626	0	3027.626	9.999+	9.999+
11	2	S2	0	9.721	3211.459	0	3211.459	9.999+	9.999+
12	2	S3	0	1.023	3175.588	0	3175.588	9.999+	9.999+
13	2	S4	0	1.342	3185.303	0	3185.303	9.999+	9.999+
14	2	S5	0	0	3174.176	0	3174.176	9.999+	9.999+
15	2	S6	0	1.384	3184.57	0	3184.57	9.999+	9.999+
16	2	S7	0	0	3176.069	0	3176.069	9.999+	9.999+
17	2	S8	0	10.011	3211.981	0	3211.981	9.999+	9.999+
18	2	S9	0	48.951	3027.032	0	3027.032	9.999+	9.999+
19	3	S1	0	46.623	2326.348	889.345	2326.348	9.999+	2.616
20	3	S2	0	7.126	2155.348	1462.182	2155.348	9.999+	1.474
21	3	S3	0	.225	2184.782	1326.391	2184.782	9.999+	1.647
22	3	S4	0	2.556	2176.038	1365.198	2176.038	9.999+	1.594
23	3	S5	0	0	2186.59	1300.632	2186.59	9.999+	1.681
24	3	S6	0	2.681	2176.722	1360.739	2176.722	9.999+	1.6
25	3	S7	0	.736	2184.312	1331.418	2184.312	9.999+	1.641
26	3	S8	0	7.38	2154.981	1460.42	2154.981	9.999+	1.476
27	3	S9	0	46.468	2326.717	889.027	2326.717	9.999+	2.617
28	4	S1	0	38.019	2384.901	751.084	2384.901	9.999+	3.175
29	4	S2	0	1.264	2256.107	1225.298	2256.107	9.999+	1.841
30	4	S3	0	1.377	2274.778	1118.406	2274.778	9.999+	2.034
31	4	S4	0	2.263	2267.837	1156.53	2267.837	9.999+	1.961
32	4	S5	0	0	2276.045	1083.413	2276.045	9.999+	2.101
33	4	S6	0	1.737	2268.353	1151.463	2268.353	9.999+	1.97
34	4	S7	0	1.603	2274.418	1124.281	2274.418	9.999+	2.023
35	4	S8	0	1.402	2255.879	1222.825	2255.879	9.999+	1.845
36	4	S9	0	37.986	2385.151	751.056	2385.151	9.999+	3.176
37	5	S1	0	73.528	3209.106	1054.327	3209.106	9.999+	3.044
38	5	S2	0	11.069	3476.456	1733.091	3476.456	9.999+	2.006
39	5	S3	0	.309	3427.189	1572.387	3427.189	9.999+	2.18
40	5	S4	0	3.628	3441.284	1618.583	3441.284	9.999+	2.126
41	5	S5	0	0	3424.832	1541.379	3424.832	9.999+	2.222
42	5	S6	0	3.159	3440.206	1613.25	3440.206	9.999+	2.132
43	5	S7	0	.908	3427.916	1578.403	3427.916	9.999+	2.172
44	5	S8	0	11.452	3477.102	1730.967	3477.102	9.999+	2.009
45	5	S9	0	73.315	3208.351	1053.958	3208.351	9.999+	3.044
46	6	S1	0	64.831	3141.079	912.824	3141.079	9.999+	3.441
47	6	S2	0	13.795	3386.294	1508.977	3386.294	9.999+	2.244
48	6	S3	0	.773	3338.175	1362.934	3338.175	9.999+	2.449
49	6	S4	0	3.071	3350.766	1398.185	3350.766	9.999+	2.397
50	6	S5	0	0	3335.905	1347.827	3335.905	9.999+	2.475
51	6	S6	0	3.203	3349.778	1394.721	3349.778	9.999+	2.402
52	6	S7	0	.676	3338.837	1366.697	3338.837	9.999+	2.443
53	6	S8	0	14.194	3386.924	1508.011	3386.924	9.999+	2.246
54	6	S9	0	64.56	3140.371	912.292	3140.371	9.999+	3.442
55	7	S1	0	32.203	2912.177	404.031	2912.177	9.999+	7.208
56	7	S2	0	7.968	3002.274	587.457	3002.274	9.999+	5.111
57	7	S3	0	0	2941.838	441.935	2941.838	9.999+	6.657



Company : Vector Structural Engineering
 Designer : STB
 Job Number : U2716.091.181
 Model Name : Ground Mount

Apr 12, 2021
 3:08 PM
 Checked By: JSP

Slab Sliding Safety Factors (Continued)

	LC	Slab	Angle[deg]	Va-xx[lb]	Vr-xx[lb]	Va-zz[lb]	Vr-zz[lb]	SR-xx	SR-zz
58	7	S4	0	3.894	2903.5	343.617	2903.5	9.999+	8.45
59	7	S5	0	0	2841.872	208.736	2841.872	9.999+	9.999+
60	7	S6	0	.972	2852.526	226.617	2852.526	9.999+	9.999+
61	7	S7	0	0	2848.167	221.676	2848.167	9.999+	9.999+
62	7	S8	0	1.312	2859.143	244.14	2859.143	9.999+	9.999+
63	7	S9	0	20.593	2799.137	147.606	2799.137	9.999+	9.999+
64	8	S1	0	16.027	2546.981	407.651	2546.981	9.999+	6.248
65	8	S2	0	6.558	2528.647	558.559	2528.647	9.999+	4.527
66	8	S3	0	.768	2600.557	362.238	2600.557	9.999+	7.179
67	8	S4	0	3.076	2622.642	304.787	2622.642	9.999+	8.605
68	8	S5	0	0	2663.11	210.669	2663.11	9.999+	9.999+
69	8	S6	0	.942	2657.506	227.034	2657.506	9.999+	9.999+
70	8	S7	0	.605	2658.474	221.586	2658.474	9.999+	9.999+
71	8	S8	0	1.312	2661.093	244.156	2661.093	9.999+	9.999+
72	8	S9	0	4.116	2660.816	147.606	2660.816	9.999+	9.999+
73	9	S1	0	2.357	2650.383	667.008	2650.383	9.999+	3.974
74	9	S2	0	1.31	2645.134	1096.636	2645.134	9.999+	2.412
75	9	S3	0	.936	2643.636	994.794	2643.636	9.999+	2.657
76	9	S4	0	.91	2643.51	1023.899	2643.51	9.999+	2.582
77	9	S5	0	0	2643.984	975.474	2643.984	9.999+	2.71
78	9	S6	0	.972	2643.535	1020.554	2643.535	9.999+	2.59
79	9	S7	0	.552	2643.605	998.563	2643.605	9.999+	2.647
80	9	S8	0	1.317	2645.202	1095.315	2645.202	9.999+	2.415
81	9	S9	0	2.307	2650.288	666.77	2650.288	9.999+	3.975
82	10	S1	0	4.095	2694.298	563.313	2694.298	9.999+	4.783
83	10	S2	0	5.706	2720.703	918.973	2720.703	9.999+	2.961
84	10	S3	0	1.8	2711.133	838.805	2711.133	9.999+	3.232
85	10	S4	0	.691	2712.359	867.398	2712.359	9.999+	3.127
86	10	S5	0	0	2711.075	812.56	2711.075	9.999+	3.336
87	10	S6	0	.264	2712.258	863.597	2712.258	9.999+	3.141
88	10	S7	0	1.202	2711.185	843.211	2711.185	9.999+	3.215
89	10	S8	0	5.8	2720.875	917.119	2720.875	9.999+	2.967
90	10	S9	0	4.054	2694.114	563.292	2694.114	9.999+	4.783
91	11	S1	0	87.756	3312.452	790.745	3312.452	9.999+	4.189
92	11	S2	0	14.956	3635.965	1299.818	3635.965	9.999+	2.797
93	11	S3	0	.535	3575.442	1179.29	3575.442	9.999+	3.032
94	11	S4	0	3.728	3592.444	1213.937	3592.444	9.999+	2.959
95	11	S5	0	0	3572.665	1156.034	3572.665	9.999+	3.09
96	11	S6	0	3.407	3591.148	1209.937	3591.148	9.999+	2.968
97	11	S7	0	.681	3576.308	1183.803	3576.308	9.999+	3.021
98	11	S8	0	15.441	3636.792	1298.225	3636.792	9.999+	2.801
99	11	S9	0	87.529	3311.514	790.469	3311.514	9.999+	4.189
100	12	S1	0	81.233	3261.432	684.618	3261.432	9.999+	4.764
101	12	S2	0	17	3568.343	1131.733	3568.343	9.999+	3.153
102	12	S3	0	1.347	3508.681	1022.2	3508.681	9.999+	3.432
103	12	S4	0	3.31	3524.555	1048.639	3524.555	9.999+	3.361
104	12	S5	0	0	3505.97	1010.87	3505.97	9.999+	3.468
105	12	S6	0	3.44	3523.327	1046.041	3523.327	9.999+	3.368
106	12	S7	0	.507	3509.499	1025.023	3509.499	9.999+	3.424
107	12	S8	0	17.498	3569.159	1131.008	3569.159	9.999+	3.156
108	12	S9	0	80.964	3260.529	684.219	3260.529	9.999+	4.765
109	13	S1	0	56.762	3089.755	303.023	3089.755	9.999+	9.999+
110	13	S2	0	12.63	3280.328	440.592	3280.328	9.999+	7.445
111	13	S3	0	.767	3211.428	331.451	3211.428	9.999+	9.689
112	13	S4	0	1.914	3189.106	257.712	3189.106	9.999+	9.999+
113	13	S5	0	0	3135.445	156.552	3135.445	9.999+	9.999+
114	13	S6	0	1.767	3150.388	169.963	3150.388	9.999+	9.999+



Company : Vector Structural Engineering
 Designer : STB
 Job Number : U2716.091.181
 Model Name : Ground Mount

Apr 12, 2021
 3:08 PM
 Checked By: JSP

Slab Sliding Safety Factors (Continued)

	LC	Slab	Angle[deg]	Va-xx[lb]	Vr-xx[lb]	Va-zz[lb]	Vr-zz[lb]	SR-xx	SR-zz
115	13	S7	0	0	3141.496	166.257	3141.496	9.999+	9.999+
116	13	S8	0	7.836	3173.323	183.105	3173.323	9.999+	9.999+
117	13	S9	0	47.989	3004.603	110.704	3004.603	9.999+	9.999+
118	14	S1	0	20.589	2815.859	305.738	2815.859	9.999+	9.21
119	14	S2	0	1.735	2925.108	418.919	2925.108	9.999+	6.983
120	14	S3	0	1.343	2955.467	271.678	2955.467	9.999+	9.999+
121	14	S4	0	3.313	2978.462	228.59	2978.462	9.999+	9.999+
122	14	S5	0	0	3001.374	158.002	3001.374	9.999+	9.999+
123	14	S6	0	.331	3004.122	170.276	3004.122	9.999+	9.999+
124	14	S7	0	.454	2999.226	166.19	2999.226	9.999+	9.999+
125	14	S8	0	7.836	3024.785	183.117	3024.785	9.999+	9.999+
126	14	S9	0	29.457	2900.862	110.704	2900.862	9.999+	9.999+
127	15	S1	0	47.459	2053.329	889.345	2053.329	9.999+	2.309
128	15	S2	0	7.253	1879.353	1462.182	1879.353	9.999+	1.285
129	15	S3	0	.225	1909.454	1326.391	1909.454	9.999+	1.44
130	15	S4	0	2.556	1900.539	1365.198	1900.539	9.999+	1.392
131	15	S5	0	0	1911.272	1300.632	1911.272	9.999+	1.469
132	15	S6	0	2.681	1901.236	1360.739	1901.236	9.999+	1.397
133	15	S7	0	.736	1908.976	1331.418	1908.976	9.999+	1.434
134	15	S8	0	7.511	1878.977	1460.42	1878.977	9.999+	1.287
135	15	S9	0	47.302	2053.713	889.027	2053.713	9.999+	2.31
136	16	S1	0	38.855	2111.881	751.084	2111.881	9.999+	2.812
137	16	S2	0	1.391	1980.113	1225.298	1980.113	9.999+	1.616
138	16	S3	0	1.377	1999.449	1118.406	1999.449	9.999+	1.788
139	16	S4	0	2.263	1992.337	1156.53	1992.337	9.999+	1.723
140	16	S5	0	0	2000.727	1083.413	2000.727	9.999+	1.847
141	16	S6	0	1.737	1992.867	1151.463	1992.867	9.999+	1.731
142	16	S7	0	1.603	1999.082	1124.281	1999.082	9.999+	1.778
143	16	S8	0	1.533	1979.875	1222.825	1979.875	9.999+	1.619
144	16	S9	0	38.82	2112.146	751.056	2112.146	9.999+	2.812
145	17	S1	0	72.692	2936.087	1054.327	2936.087	9.999+	2.785
146	17	S2	0	10.942	3200.462	1733.091	3200.462	9.999+	1.847
147	17	S3	0	.309	3151.861	1572.387	3151.861	9.999+	2.005
148	17	S4	0	3.628	3165.785	1618.583	3165.785	9.999+	1.956
149	17	S5	0	0	3149.514	1541.379	3149.514	9.999+	2.043
150	17	S6	0	3.159	3164.719	1613.25	3164.719	9.999+	1.962
151	17	S7	0	.908	3152.58	1578.403	3152.58	9.999+	1.997
152	17	S8	0	11.321	3201.098	1730.967	3201.098	9.999+	1.849
153	17	S9	0	72.481	2935.346	1053.958	2935.346	9.999+	2.785
154	18	S1	0	63.996	2868.06	912.824	2868.06	9.999+	3.142
155	18	S2	0	13.668	3110.3	1508.977	3110.3	9.999+	2.061
156	18	S3	0	.773	3062.847	1362.934	3062.847	9.999+	2.247
157	18	S4	0	3.071	3075.266	1398.185	3075.266	9.999+	2.199
158	18	S5	0	0	3060.587	1347.827	3060.587	9.999+	2.271
159	18	S6	0	3.203	3074.291	1394.721	3074.291	9.999+	2.204
160	18	S7	0	.676	3063.501	1366.697	3063.501	9.999+	2.242
161	18	S8	0	14.063	3110.92	1508.011	3110.92	9.999+	2.063
162	18	S9	0	63.727	2867.366	912.292	2867.366	9.999+	3.143
163	19	S1	0	31.367	2639.158	404.031	2639.158	9.999+	6.532
164	19	S2	0	7.84	2726.279	587.457	2726.279	9.999+	4.641
165	19	S3	0	0	2666.51	441.935	2666.51	9.999+	6.034
166	19	S4	0	3.894	2628.001	343.617	2628.001	9.999+	7.648
167	19	S5	0	0	2566.554	208.736	2566.554	9.999+	9.999+
168	19	S6	0	.972	2577.039	226.617	2577.039	9.999+	9.999+
169	19	S7	0	0	2572.831	221.676	2572.831	9.999+	9.999+
170	19	S8	0	1.181	2583.139	244.14	2583.139	9.999+	9.999+
171	19	S9	0	19.759	2526.132	147.606	2526.132	9.999+	9.999+

Slab Sliding Safety Factors (Continued)

	LC	Slab	Angle[deg]	Va-xx[lb]	Vr-xx[lb]	Va-zz[lb]	Vr-zz[lb]	SR-xx	SR-zz
172	20	S1	0	16.863	2273.962	407.651	2273.962	9.999+	5.578
173	20	S2	0	6.686	2252.653	558.559	2252.653	9.999+	4.033
174	20	S3	0	.768	2325.229	362.238	2325.229	9.999+	6.419
175	20	S4	0	3.076	2347.143	304.787	2347.143	9.999+	7.701
176	20	S5	0	0	2387.792	210.669	2387.792	9.999+	9.999+
177	20	S6	0	.942	2382.019	227.034	2382.019	9.999+	9.999+
178	20	S7	0	.605	2383.138	221.586	2383.138	9.999+	9.999+
179	20	S8	0	1.181	2385.089	244.156	2385.089	9.999+	9.769
180	20	S9	0	4.95	2387.811	147.606	2387.811	9.999+	9.999+

Envelope Slab Soil Pressures

	Label	UC	LC	Soil Pressure[psf]	Allowable Bearing[psf]	Point
1	S1	.43	5	644.378	1500	N254
2	S2	.531	5	795.962	1500	N261
3	S3	.512	5	767.411	1500	N268
4	S4	.519	5	778.439	1500	N275
5	S5	.505	5	758.173	1500	N282
6	S6	.518	5	777.024	1500	N289
7	S7	.513	5	768.932	1500	N296
8	S8	.53	5	795.517	1500	N303
9	S9	.43	5	644.27	1500	N310



Company:		Date:	5/14/2018
Engineer:		Page:	1/6
Project:			
Address:			
Phone:			
E-mail:			

1. Project information

Customer company:
Customer contact name:
Customer e-mail:
Comment:

Project description:
Location:
Fastening description:

2. Input Data & Anchor Parameters

General

Design method: ACI 318-14
Units: Imperial units

Anchor Information:

Anchor type: Bonded anchor
Material: F1554 Grade 36
Diameter (inch): 0.375
Effective Embedment depth, h_{ef} (inch): 6.000
Code report: ICC-ES ESR-4057
Anchor category: -
Anchor ductility: Yes
 h_{min} (inch): 7.25
 c_{ac} (inch): 10.99
 c_{min} (inch): 1.75
 s_{min} (inch): 3.00

Base Material

Concrete: Normal-weight
Concrete thickness, h (inch): 30.00
State: Cracked
Compressive strength, f'_c (psi): 2500
 $\Psi_{c,v}$: 1.0
Reinforcement condition: B tension, B shear
Supplemental reinforcement: Not applicable
Reinforcement provided at corners: No
Ignore concrete breakout in tension: No
Ignore concrete breakout in shear: No
Hole condition: Dry concrete
Inspection: Periodic
Temperature range, Short/Long: 150/110°F
Ignore 6do requirement: Not applicable
Build-up grout pad: No

Base Plate

Length x Width x Thickness (inch): 4.75 x 4.75 x 0.31

Recommended Anchor

Anchor Name: SET-3G - SET-3G w/ 3/8"Ø F1554 Gr. 36
Code Report: ICC-ES ESR-4057





Company:		Date:	5/14/2018
Engineer:		Page:	2/6
Project:			
Address:			
Phone:			
E-mail:			

Load and Geometry

Load factor source: ACI 318 Section 5.3

Load combination: not set

Seismic design: No

Anchors subjected to sustained tension: No

Apply entire shear load at front row: No

Anchors only resisting wind and/or seismic loads: No

Strength level loads:

N_{ua} [lb]: 4470

V_{uax} [lb]: 175

V_{uay} [lb]: -3010

M_{ux} [ft-lb]: 0

M_{uy} [ft-lb]: 0

M_{uz} [ft-lb]: 0

<Figure 1>

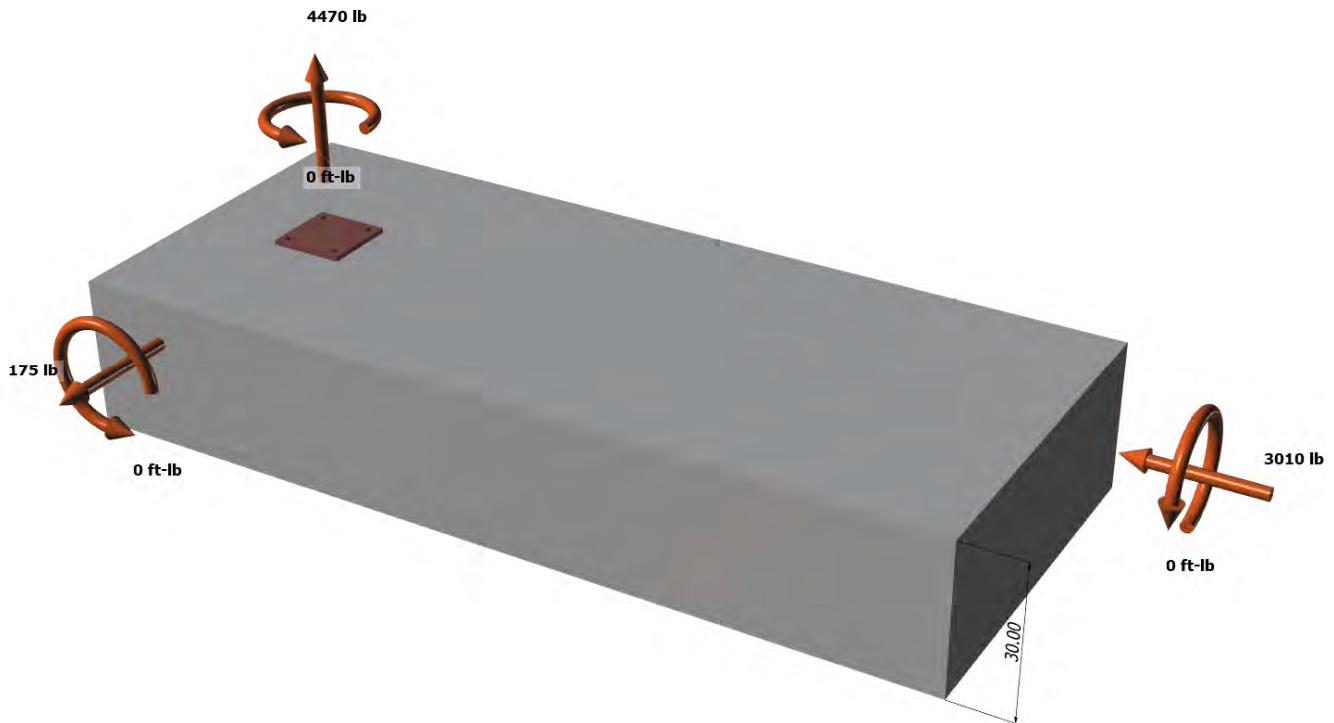



Company:		Date:	5/14/2018
Engineer:		Page:	3/6
Project:			
Address:			
Phone:			
E-mail:			

<Figure 2>

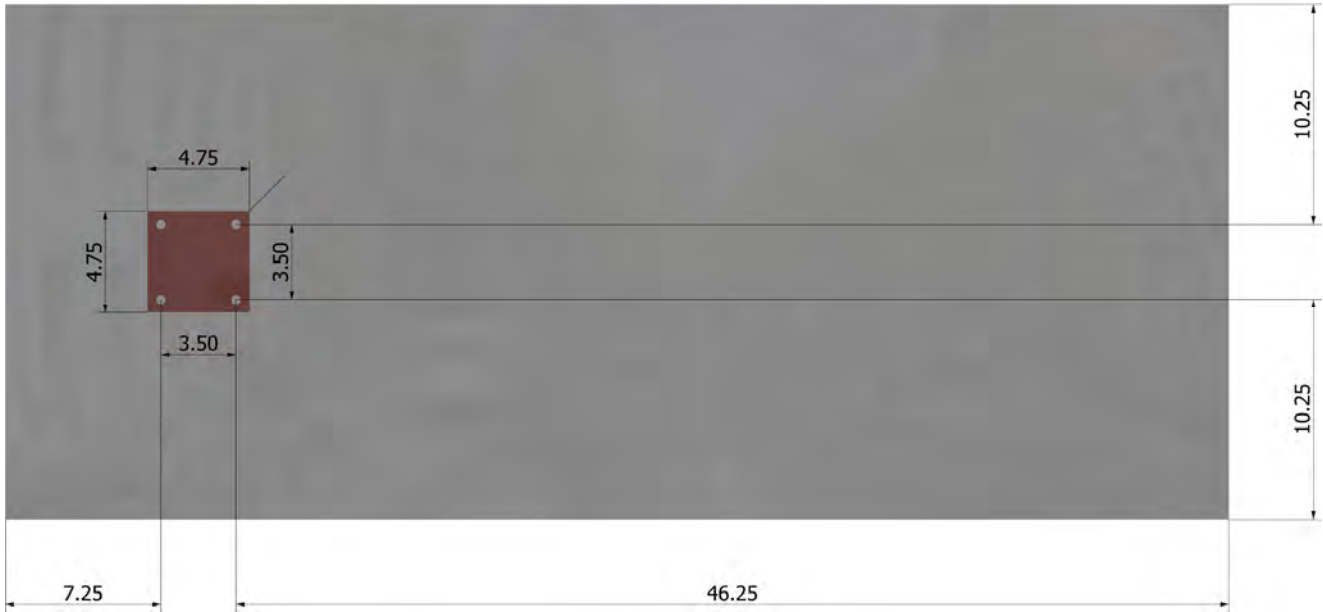



Company:		Date:	5/14/2018
Engineer:		Page:	4/6
Project:			
Address:			
Phone:			
E-mail:			

3. Resulting Anchor Forces

Anchor	Tension load, N _{ua} (lb)	Shear load x, V _{uax} (lb)	Shear load y, V _{uay} (lb)	Shear load combined, $\sqrt{(V_{uax})^2 + (V_{uay})^2}$ (lb)
1	1117.5	43.8	-752.5	753.8
2	1117.5	43.8	-752.5	753.8
3	1117.5	43.8	-752.5	753.8
4	1117.5	43.8	-752.5	753.8
Sum	4470.0	175.0	-3010.0	3015.1

Maximum concrete compression strain (%): 0.00
 Maximum concrete compression stress (psi): 0
 Resultant tension force (lb): 4470
 Resultant compression force (lb): 0
 Eccentricity of resultant tension forces in x-axis, e'_{Nx} (inch): 0.00
 Eccentricity of resultant tension forces in y-axis, e'_{Ny} (inch): 0.00
 Eccentricity of resultant shear forces in x-axis, e'_{Vx} (inch): 0.00
 Eccentricity of resultant shear forces in y-axis, e'_{Vy} (inch): 0.00

<Figure 3>

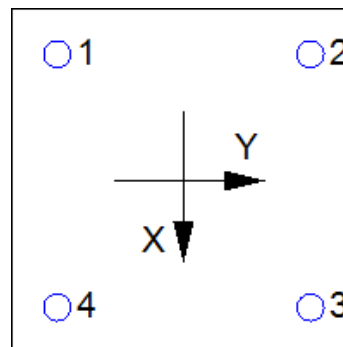

4. Steel Strength of Anchor in Tension (Sec. 17.4.1)

N _{sa} (lb)	φ	φN _{sa} (lb)
4525	0.75	3394

5. Concrete Breakout Strength of Anchor in Tension (Sec. 17.4.2)

$$N_b = K_c \lambda_a \sqrt{f_c} h_{ef}^{1.5} \text{ (Eq. 17.4.2.2a)}$$

K _c	λ _a	f _c (psi)	h _{ef} (in)	N _b (lb)
17.0	1.00	2500	6.000	12492

$$\phi N_{cbg} = \phi (A_{Nc} / A_{Nco}) \psi_{ec,N} \psi_{ed,N} \psi_{c,N} \psi_{cp,N} N_b \text{ (Sec. 17.3.1 \& Eq. 17.4.2.1b)}$$

A _{Nc} (in ²)	A _{Nco} (in ²)	c _{a,min} (in)	ψ _{ec,N}	ψ _{ed,N}	ψ _{c,N}	ψ _{cp,N}	N _b (lb)	φ	φN _{cbg} (lb)
424.63	324.00	7.25	1.000	0.942	1.00	1.000	12492	0.65	10021

6. Adhesive Strength of Anchor in Tension (Sec. 17.4.5)

$$\tau_{k,cr} = \tau_{k,cr,short-term} K_{sat} (f_c / 2,500)^n$$

τ _{k,cr} (psi)	f _{short-term}	K _{sat}	f _c (psi)	n	τ _{k,cr} (psi)
1346	1.00	1.00	2500	0.24	1346

$$N_{ba} = \lambda_a \tau_{cr} \pi d_a h_{ef} \text{ (Eq. 17.4.5.2)}$$

λ _a	τ _{cr} (psi)	d _a (in)	h _{ef} (in)	N _{ba} (lb)
1.00	1346	0.38	6.000	9514

$$\phi N_{ag} = \phi (A_{Na} / A_{Na0}) \psi_{ec,Na} \psi_{ed,Na} \psi_{cp,Na} N_{ba} \text{ (Sec. 17.3.1 \& Eq. 17.4.5.1b)}$$

A _{Na} (in ²)	A _{Na0} (in ²)	c _{a,min} (in)	ψ _{ec,Na}	ψ _{ed,Na}	ψ _{cp,Na}	N _{ba} (lb)	φ	φN _{ag} (lb)
198.45	112.09	5.29	7.25	1.000	1.000	9514	0.55	9265



Company:		Date:	5/14/2018
Engineer:		Page:	5/6
Project:			
Address:			
Phone:			
E-mail:			

8. Steel Strength of Anchor in Shear (Sec. 17.5.1)

V_{sa} (lb)	ϕ_{grout}	ϕ	$\phi_{grout}\phi V_{sa}$ (lb)
2715	1.0	0.65	1765

9. Concrete Breakout Strength of Anchor in Shear (Sec. 17.5.2)

Shear perpendicular to edge in x-direction:

$V_{bx} = \min|7(l_e / d_a)^{0.2} \sqrt{d_a} \lambda_a \sqrt{f_c} c_{a1}^{1.5}; 9 \lambda_a \sqrt{f_c} c_{a1}^{1.5}|$ (Eq. 17.5.2.2a & Eq. 17.5.2.2b)

l_e (in)	d_a (in)	λ_a	f_c (psi)	c_{a1} (in)	V_{bx} (lb)
3.00	0.375	1.00	2500	13.75	16564

$\phi V_{cbgx} = \phi (A_{Vc} / A_{Vco}) \Psi_{ec,V} \Psi_{ed,V} \Psi_{c,V} \Psi_{h,V} V_{bx}$ (Sec. 17.3.1 & Eq. 17.5.2.1b)

A_{Vc} (in ²)	A_{Vco} (in ²)	$\Psi_{ec,V}$	$\Psi_{ed,V}$	$\Psi_{c,V}$	$\Psi_{h,V}$	V_{bx} (lb)	ϕ	ϕV_{cbgx} (lb)
647.11	850.78	1.000	0.805	1.000	1.000	16564	0.70	7103

Shear perpendicular to edge in y-direction:

$V_{by} = \min|7(l_e / d_a)^{0.2} \sqrt{d_a} \lambda_a \sqrt{f_c} c_{a1}^{1.5}; 9 \lambda_a \sqrt{f_c} c_{a1}^{1.5}|$ (Eq. 17.5.2.2a & Eq. 17.5.2.2b)

l_e (in)	d_a (in)	λ_a	f_c (psi)	c_{a1} (in)	V_{by} (lb)
3.00	0.375	1.00	2500	10.75	11450

$\phi V_{cbgy} = \phi (A_{Vc} / A_{Vco}) \Psi_{ec,V} \Psi_{ed,V} \Psi_{c,V} \Psi_{h,V} V_{by}$ (Sec. 17.3.1 & Eq. 17.5.2.1b)

A_{Vc} (in ²)	A_{Vco} (in ²)	$\Psi_{ec,V}$	$\Psi_{ed,V}$	$\Psi_{c,V}$	$\Psi_{h,V}$	V_{by} (lb)	ϕ	ϕV_{cbgy} (lb)
387.00	520.03	1.000	0.891	1.000	1.000	11450	0.70	5313

Shear parallel to edge in x-direction:

$V_{by} = \min|7(l_e / d_a)^{0.2} \sqrt{d_a} \lambda_a \sqrt{f_c} c_{a1}^{1.5}; 9 \lambda_a \sqrt{f_c} c_{a1}^{1.5}|$ (Eq. 17.5.2.2a & Eq. 17.5.2.2b)

l_e (in)	d_a (in)	λ_a	f_c (psi)	c_{a1} (in)	V_{by} (lb)
3.00	0.375	1.00	2500	7.25	6342

$\phi V_{cbgx} = \phi (2)(A_{Vc} / A_{Vco}) \Psi_{ec,V} \Psi_{ed,V} \Psi_{c,V} \Psi_{h,V} V_{by}$ (Sec. 17.3.1, 17.5.2.1(c) & Eq. 17.5.2.1b)

A_{Vc} (in ²)	A_{Vco} (in ²)	$\Psi_{ec,V}$	$\Psi_{ed,V}$	$\Psi_{c,V}$	$\Psi_{h,V}$	V_{by} (lb)	ϕ	ϕV_{cbgx} (lb)
261.00	236.53	1.000	1.000	1.000	1.000	6342	0.70	9797

Shear parallel to edge in y-direction:

$V_{bx} = \min|7(l_e / d_a)^{0.2} \sqrt{d_a} \lambda_a \sqrt{f_c} c_{a1}^{1.5}; 9 \lambda_a \sqrt{f_c} c_{a1}^{1.5}|$ (Eq. 17.5.2.2a & Eq. 17.5.2.2b)

l_e (in)	d_a (in)	λ_a	f_c (psi)	c_{a1} (in)	V_{bx} (lb)
3.00	0.375	1.00	2500	10.25	10661

$\phi V_{cbgy} = \phi (2)(A_{Vc} / A_{Vco}) \Psi_{ec,V} \Psi_{ed,V} \Psi_{c,V} \Psi_{h,V} V_{bx}$ (Sec. 17.3.1, 17.5.2.1(c) & Eq. 17.5.2.1b)

A_{Vc} (in ²)	A_{Vco} (in ²)	$\Psi_{ec,V}$	$\Psi_{ed,V}$	$\Psi_{c,V}$	$\Psi_{h,V}$	V_{bx} (lb)	ϕ	ϕV_{cbgy} (lb)
401.67	472.78	1.000	1.000	1.000	1.000	10661	0.70	12680

10. Concrete Pryout Strength of Anchor in Shear (Sec. 17.5.3)

$\phi V_{cp} = \phi \min|k_{cp} N_{ag}; k_{cp} N_{cbg}| = \phi \min|k_{cp}(A_{Na} / A_{Na0}) \Psi_{ec,Na} \Psi_{ed,Na} \Psi_{cp,Na} N_{ba}; k_{cp}(A_{Nc} / A_{Nco}) \Psi_{ec,N} \Psi_{ed,N} \Psi_{cp,N} N_{cb}|$ (Sec. 17.3.1 & Eq. 17.5.3.1b)

k_{cp}	A_{Na} (in ²)	A_{Na0} (in ²)	$\Psi_{ed,Na}$	$\Psi_{ec,Na}$	$\Psi_{cp,Na}$	N_{ba} (lb)	N_a (lb)
2.0	198.45	112.09	1.000	1.000	1.000	9514	16845

A_{Nc} (in ²)	A_{Nco} (in ²)	$\Psi_{ec,N}$	$\Psi_{ed,N}$	$\Psi_{c,N}$	$\Psi_{cp,N}$	N_b (lb)	N_{cb} (lb)	ϕ
424.63	324.00	1.000	0.942	1.000	1.000	12492	15417	0.70

Input data and results must be checked for agreement with the existing circumstances, the standards and guidelines must be checked for plausibility.



Company:		Date:	5/14/2018
Engineer:		Page:	6/6
Project:			
Address:			
Phone:			
E-mail:			

ϕV_{cpq} (lb)
21584

11. Results

Interaction of Tensile and Shear Forces (Sec. R17.6)

Tension	Factored Load, N_{ua} (lb)	Design Strength, ϕN_n (lb)	Ratio	Status	
Steel	1118	3394	0.33	Pass	
Concrete breakout	4470	10021	0.45	Pass	
Adhesive	4470	9265	0.48	Pass (Governs)	
Shear	Factored Load, V_{ua} (lb)	Design Strength, ϕV_n (lb)	Ratio	Status	
Steel	754	1765	0.43	Pass	
T Concrete breakout x+	175	7103	0.02	Pass	
T Concrete breakout y-	3010	5313	0.57	Pass	
Concrete breakout y-	88	9797	0.01	Pass	
Concrete breakout x-	1505	12680	0.12	Pass	
Concrete breakout, combined	-	-	0.57	Pass (Governs)	
Pryout	3015	21584	0.14	Pass	
Interaction check	$(N_{ua}/\phi N_{ua})^{5/3}$	$(V_{ua}/\phi V_{ua})^{5/3}$	Combined Ratio	Permissible	Status
Sec. R17.6	0.30	0.39	68.5%	1.0	Pass

SET-3G w/ 3/8"Ø F1554 Gr. 36 with hef = 6.000 inch meets the selected design criteria.

12. Warnings

- Designer must exercise own judgement to determine if this design is suitable.
- Refer to manufacturer's product literature for hole cleaning and installation instructions.



JOB NO.: U2716-070-181

DESIGNED: STB

PROJECT: Ground Mount Package for Ontario Canada

Framing Analysis

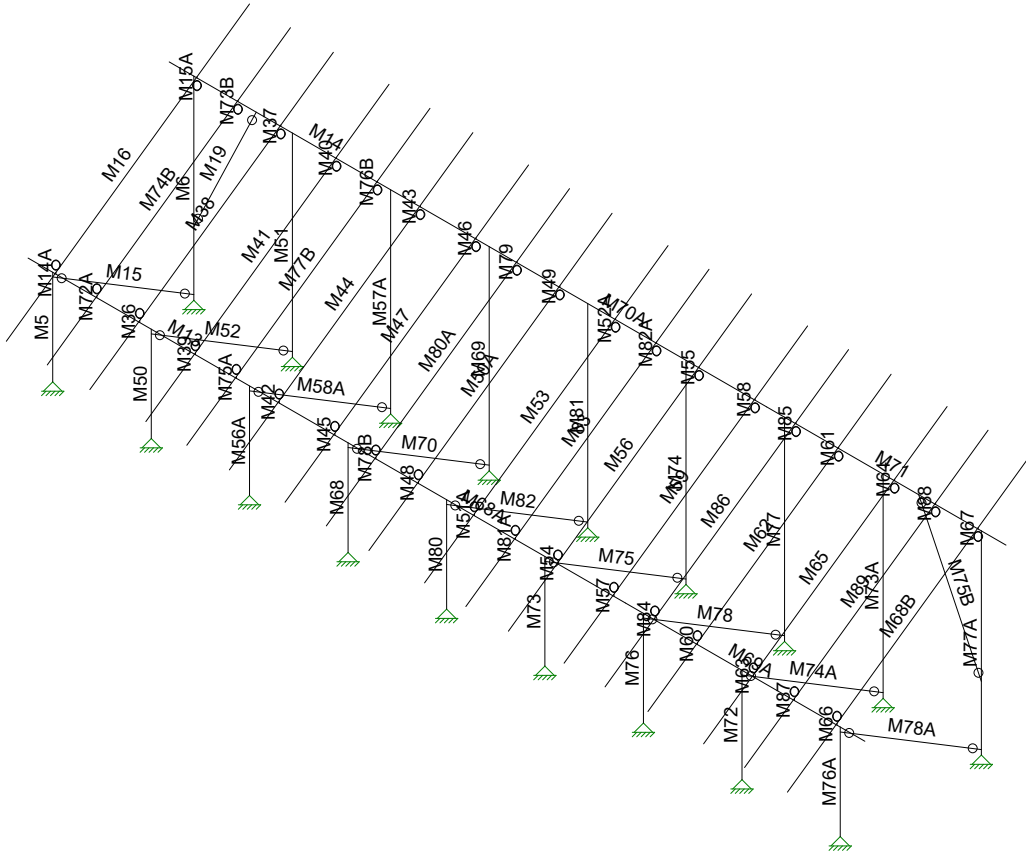

Vector Structural Engineeri...

STB

U2716.091.191

Ground Mount

SK - 3

Apr 12, 2021 at 3:06 PM

Sunmodo Sunturf A3 v7 85x45.r3d

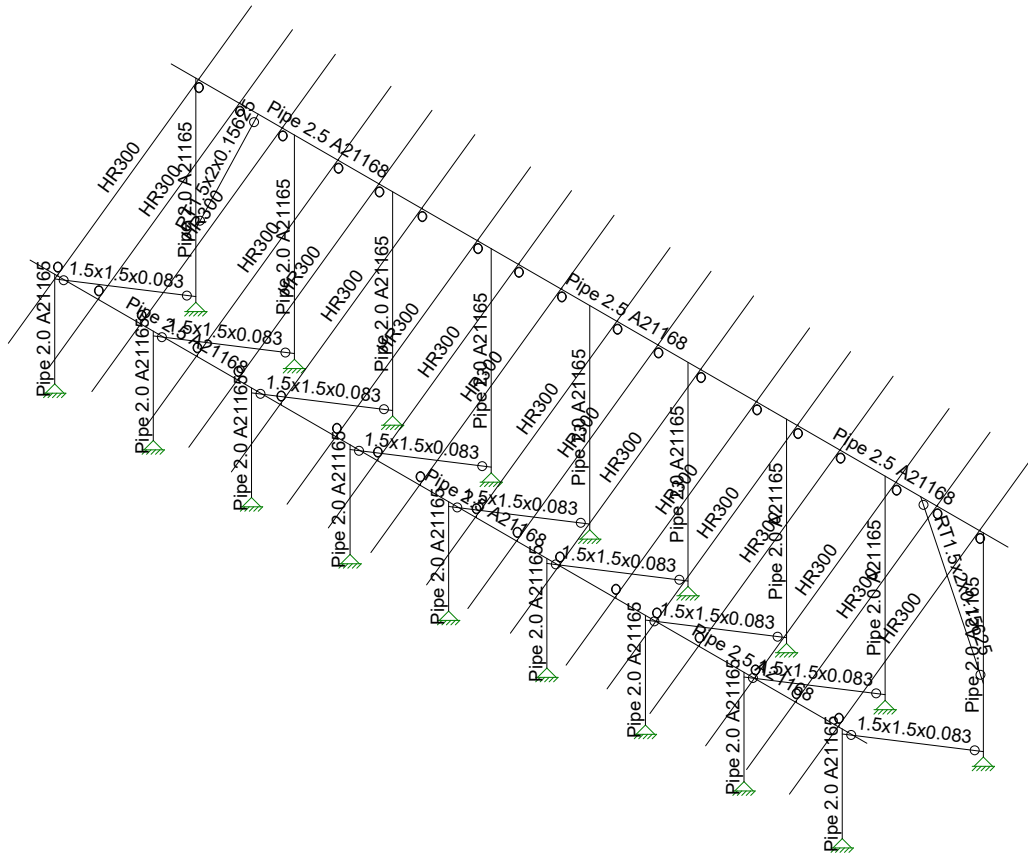

Vector Structural Engineeri...

STB

U2716.091.191

Ground Mount

SK - 4

Apr 12, 2021 at 3:06 PM

Sunmodo Sunturf A3 v7 85x45.r3d

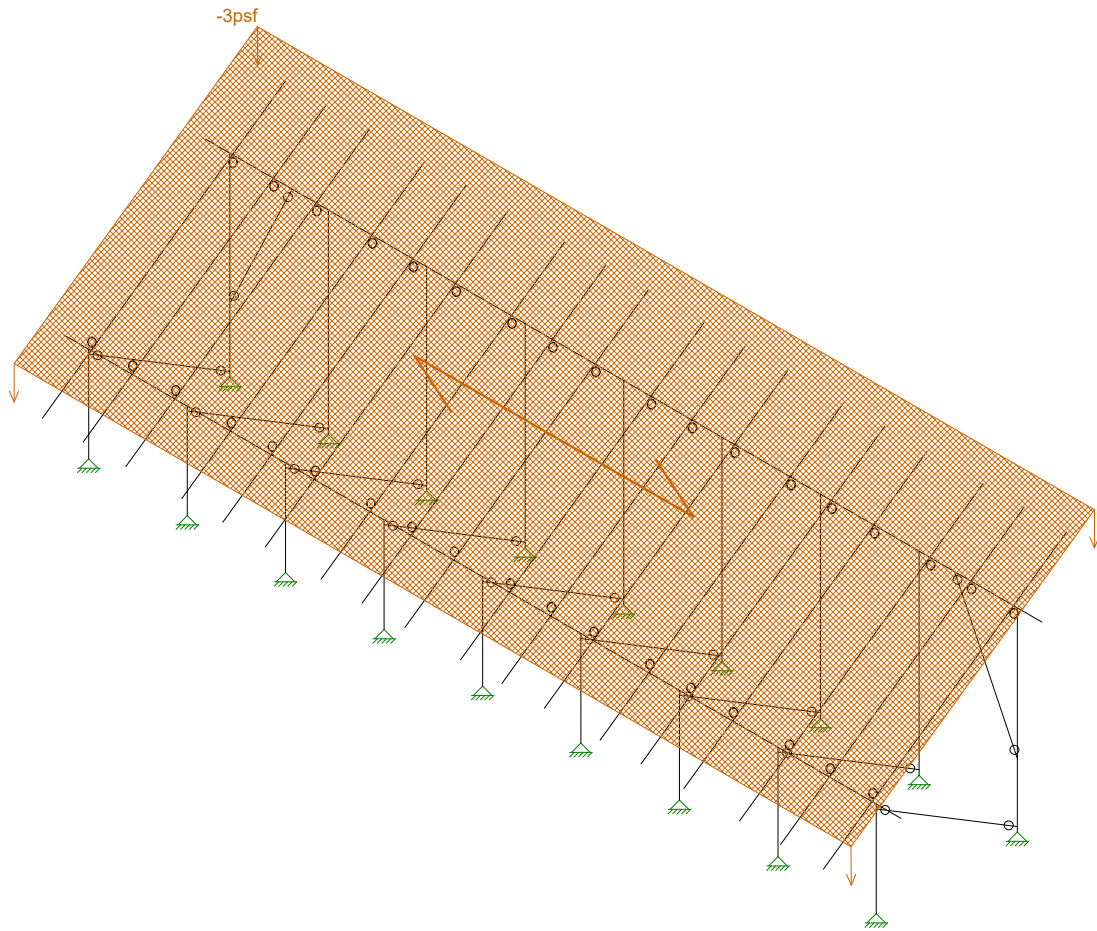

Loads: BLC 2, Solar Panel Weight

Vector Structural Engineeri...
STB
U2716.091.191

Ground Mount

SK - 5

Apr 12, 2021 at 3:06 PM

Sunmodo Sunturf A3 v7 85x45.r3d

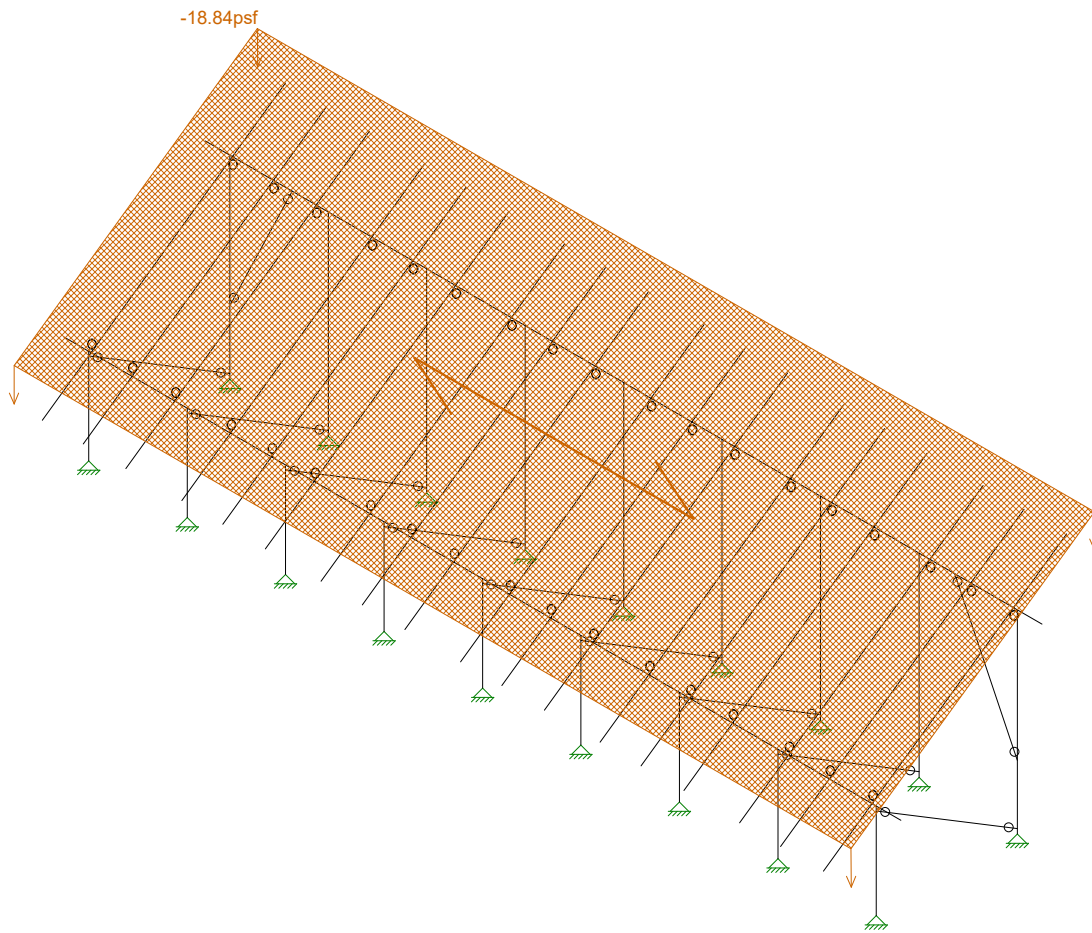

Loads: BLC 3, Roof Live/Snow

Vector Structural Engineeri...
STB
U2716.091.191

Ground Mount

SK - 6

Apr 12, 2021 at 3:06 PM

Sunmodo Sunturf A3 v7 85x45.r3d

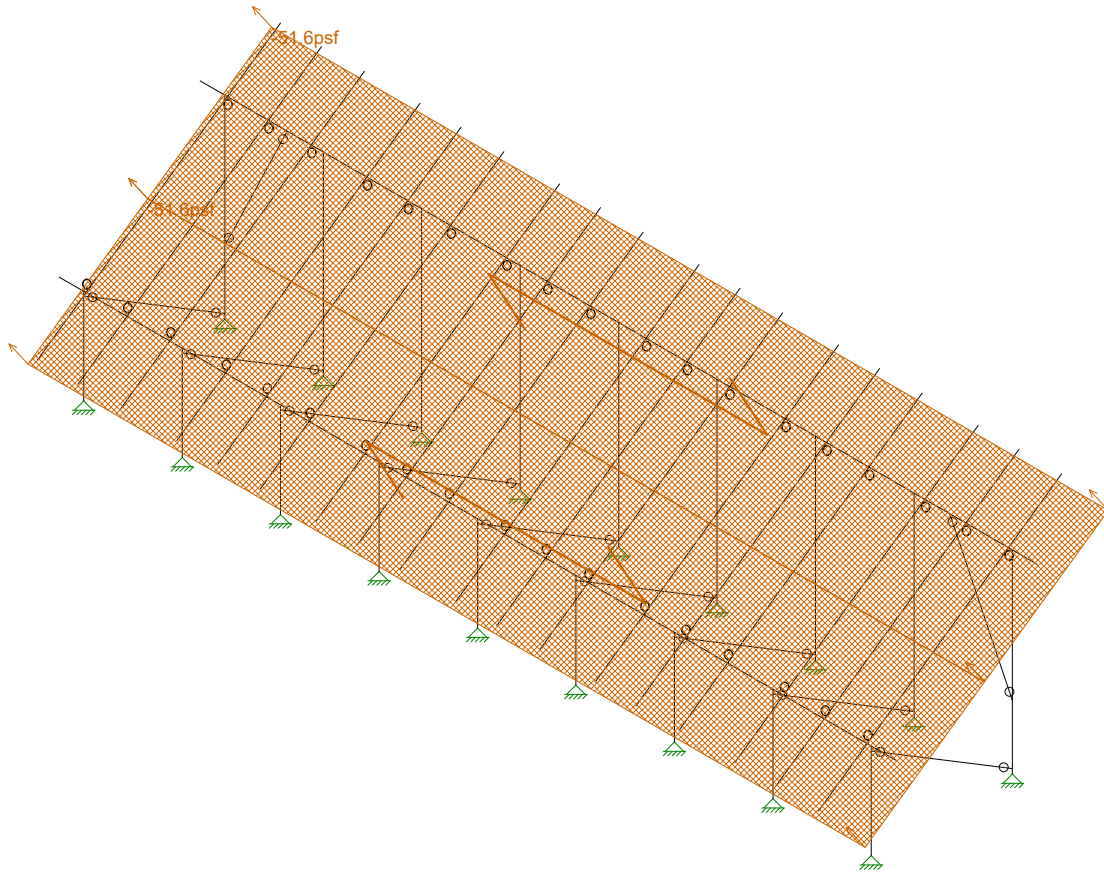

Loads: BLC 4, Wind A 0 deg

Vector Structural Engineeri..	Ground Mount	SK - 7
STB		Apr 12, 2021 at 3:06 PM
U2716.091.191		Sunmodo Sunturf A3 v7 85x45.r3d

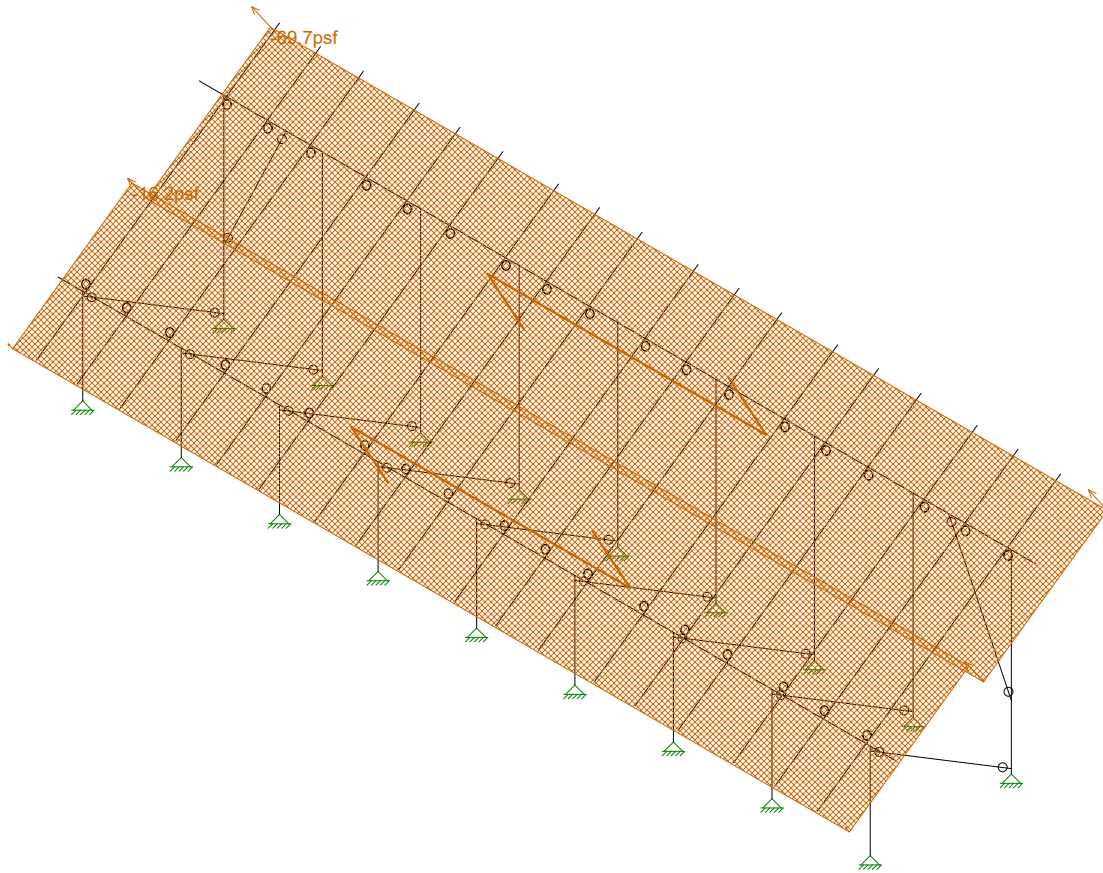

Loads: BLC 5, Wind B 0 deg

Vector Structural Engineeri..	Ground Mount	SK - 8
STB		Apr 12, 2021 at 3:07 PM
U2716.091.191		Sunmodo Sunturf A3 v7 85x45.r3d

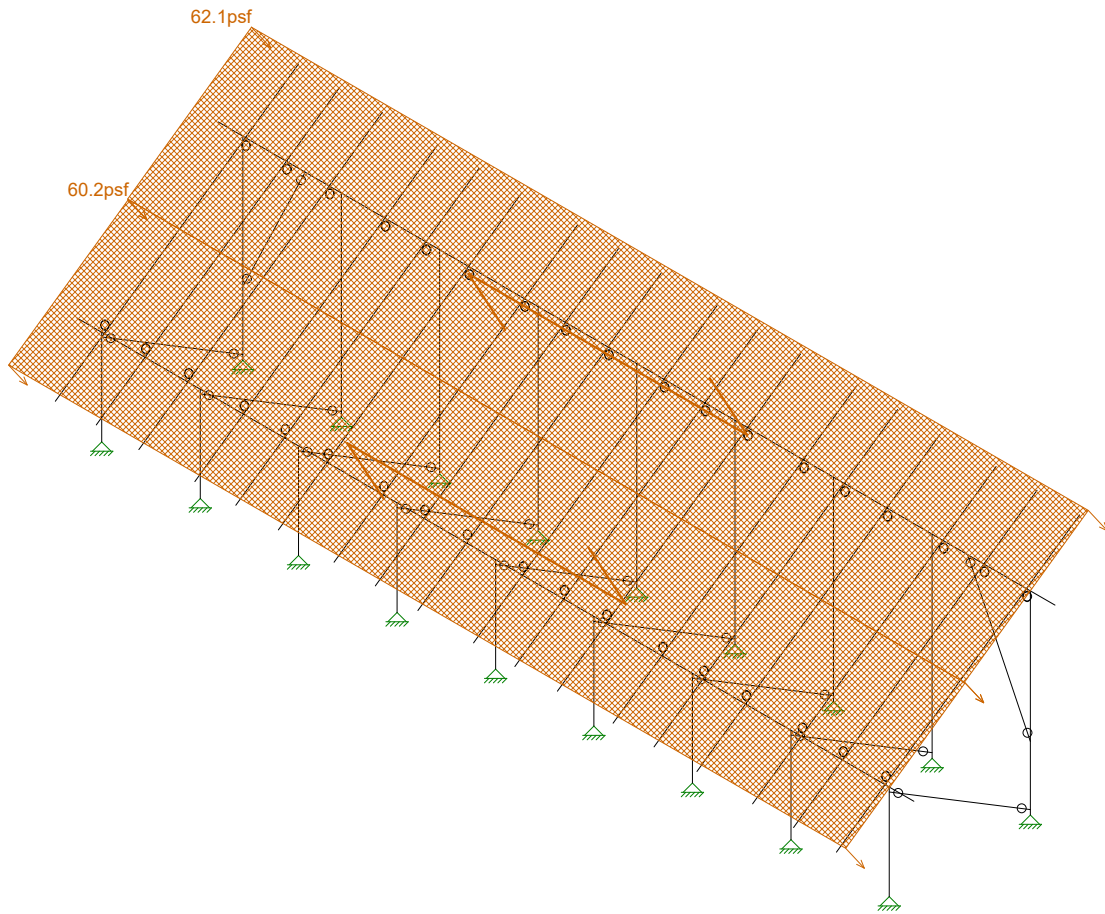

Loads: BLC 6, Wind A 180 deg

Vector Structural Engineeri...
STB
U2716.091.191

Ground Mount

SK - 9

Apr 12, 2021 at 3:07 PM

Sunmodo Sunturf A3 v7 85x45.r3d

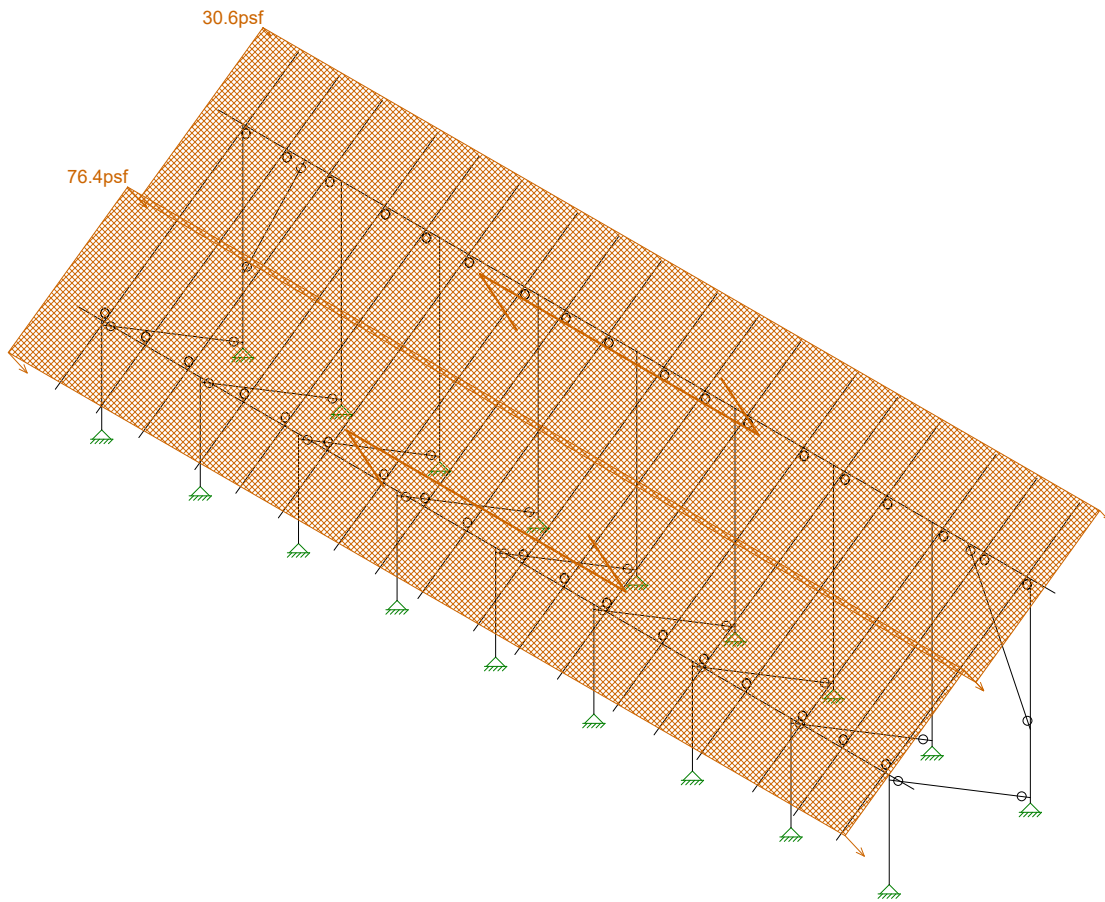

Loads: BLC 7, Wind B 180 deg

Vector Structural Engineeri...	Ground Mount	SK - 10
STB		Apr 12, 2021 at 3:07 PM
U2716.091.191		Sunmodo Sunturf A3 v7 85x45.r3d

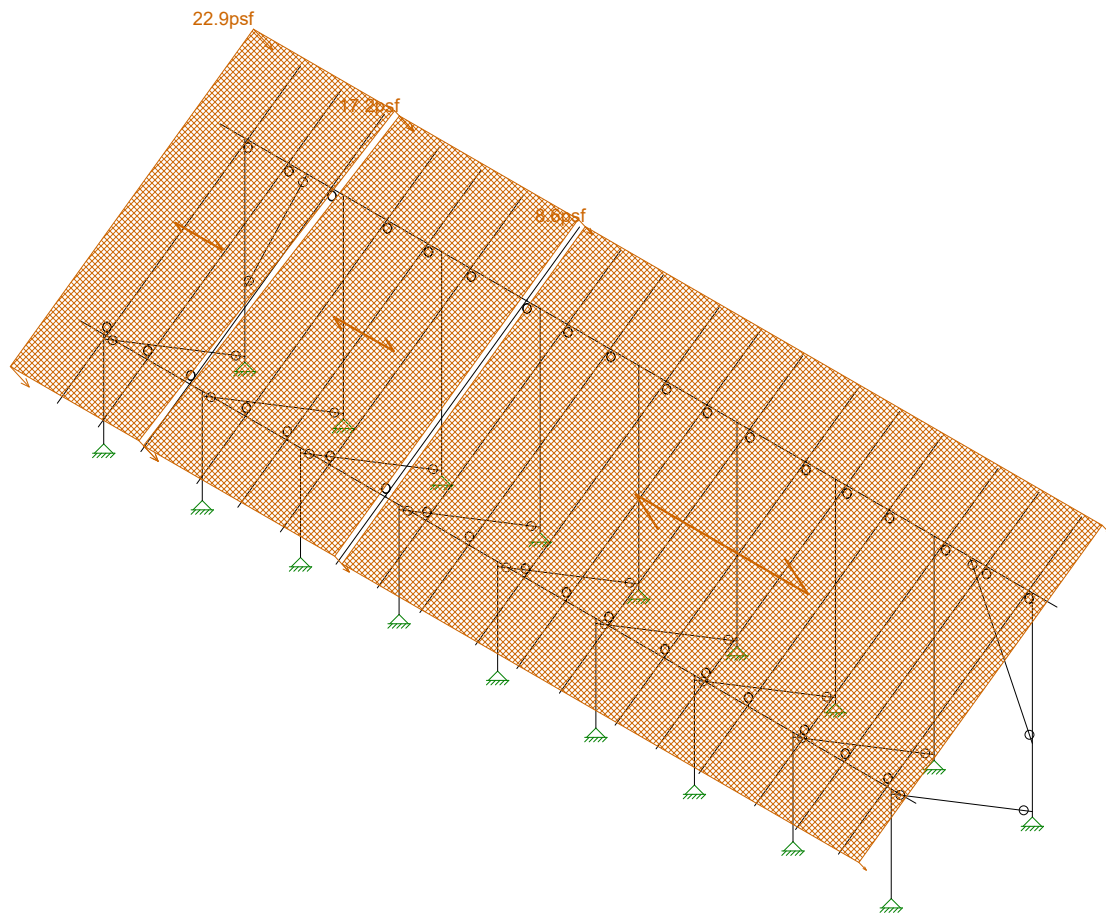

Loads: BLC 8, Wind A 90

Vector Structural Engineeri...	Ground Mount	SK - 11
STB		Apr 12, 2021 at 3:07 PM
U2716.091.191		Sunmodo Sunturf A3 v7 85x45.r3d

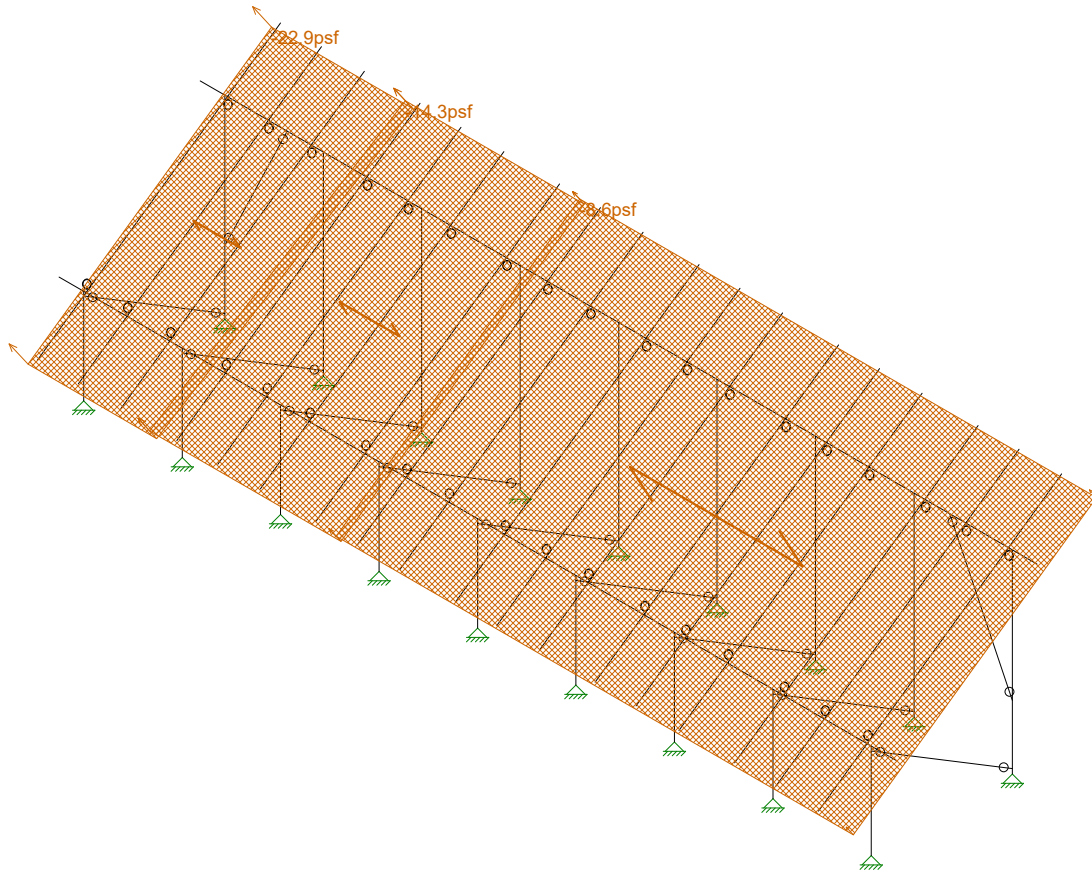

Loads: BLC 9, Wind B 90

Vector Structural Engineeri..	Ground Mount	SK - 12
STB		Apr 12, 2021 at 3:07 PM
U2716.091.191		Sunmodo Sunturf A3 v7 85x45.r3d



Code Check (Env)	
Black	No Calc
Red	> 1.0
Magenta	.90-1.0
Green	.75-.90
Cyan	.50-.75
Blue	0-.50

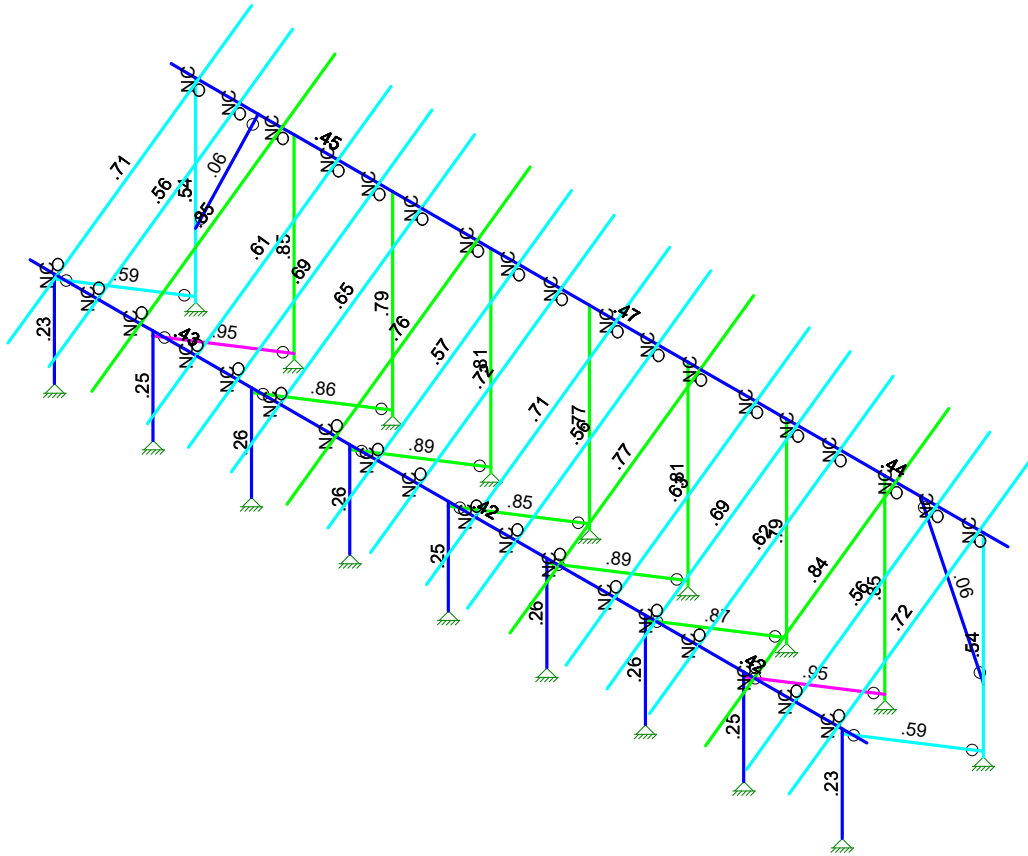

Member Code Checks Displayed (Enveloped)
Envelope Only Solution

Vector Structural Engineeri...
STB
U2716.091.191

Ground Mount

SK - 1
Apr 12, 2021 at 3:05 PM
Sunmodo Sunturf A3 v7 85x45.r3d



Company : Vector Structural Engineering
 Designer : STB
 Job Number : U2716.091.191
 Model Name : Ground Mount

Apr 12, 2021
 3:07 PM
 Checked By: _____

(Global) Model Settings

Display Sections for Member Calcs	5
Max Internal Sections for Member Calcs	97
Include Shear Deformation?	Yes
Increase Nailing Capacity for Wind?	Yes
Include Warping?	Yes
Trans Load Btwn Intersecting Wood Wall?	Yes
Area Load Mesh (in^2)	144
Merge Tolerance (in)	.12
P-Delta Analysis Tolerance	0.50%
Include P-Delta for Walls?	Yes
Automatically Iterate Stiffness for Walls?	Yes
Max Iterations for Wall Stiffness	3
Gravity Acceleration (in/sec^2)	386.4
Wall Mesh Size (in)	24
Eigensolution Convergence Tol. (1.E-)	4
Vertical Axis	Y
Global Member Orientation Plane	XZ
Static Solver	Sparse Accelerated
Dynamic Solver	Accelerated Solver

Hot Rolled Steel Code	AISC 15th(360-16): ASD
Adjust Stiffness?	Yes(Iterative)
RISACONNECTION CODE	AISC 15th(360-16): ASD
Cold Formed Steel Code	AISI S100-16: ASD
Wood Code	AWC NDS-18: ASD
Wood Temperature	< 100F
Concrete Code	ACI 318-14
Masonry Code	None
Aluminum Code	AA ADM1-15: ASD - Building
Stainless Steel Code	AISC 14th(360-10): ASD
Adjust Stiffness?	Yes(Iterative)

Number of Shear Regions	4
Region Spacing Increment (in)	4
Biaxial Column Method	Exact Integration
Parame Beta Factor (PCA)	.65
Concrete Stress Block	Rectangular
Use Cracked Sections?	Yes
Use Cracked Sections Slab?	No
Bad Framing Warnings?	No
Unused Force Warnings?	Yes
Min 1 Bar Diam. Spacing?	No
Concrete Rebar Set	REBAR SET ASTMA615
Min % Steel for Column	1
Max % Steel for Column	8



(Global) Model Settings, Continued

Seismic Code	ASCE 7-16
Seismic Base Elevation (in)	15600
Add Base Weight?	Yes
Ct X	.02
Ct Z	.02
T X (sec)	Not Entered
T Z (sec)	Not Entered
R X	3
R Z	3
Ct Exp. X	.75
Ct Exp. Z	.75
SD1	1
SDS	1
S1	1
TL (sec)	5
Risk Cat	I or II
Drift Cat	Other
Om Z	1
Om X	1
Cd Z	4
Cd X	4
Rho Z	1
Rho X	1

Hot Rolled Steel Properties

	Label	E [ksi]	G [ksi]	Nu	Therm (/1E5 F)	Density[lb/ft^3]	Yield[psi]	Ry	Fu[psi]	Rt
1	A992	29000	11154	.3	.65	490	50000	1.1	65000	1.1
2	A36 Gr.36	29000	11154	.3	.65	490	36000	1.5	58000	1.2
3	A572 Gr.50	29000	11154	.3	.65	490	50000	1.1	65000	1.1
4	A500 Gr.B R...	29000	11154	.3	.65	527	42000	1.4	58000	1.3
5	A500 Gr.B Re...	29000	11154	.3	.65	527	46000	1.4	58000	1.3
6	A53 Gr.B	29000	11154	.3	.65	490	35000	1.6	60000	1.2
7	A1085	29000	11154	.3	.65	490	50000	1.4	65000	1.3

Aluminum Properties

	Label	E [ksi]	G [ksi]	Nu	Therm (...Density[... Table B.4	kt	Ftu[psi]	Fty[psi]	Fcy[psi]	Fsu[psi]	Ct
1	3003-H14	10100	3787.5	.33	1.3 172.8 Table B.4-1	1	19000	16000	13000	12000	141
2	6061-T6	10100	3787.5	.33	1.3 172.8 Table B.4-2	1	38000	35000	35000	24000	141
3	6063-T5	10100	3787.5	.33	1.3 172.8 Table B.4-2	1	22000	16000	16000	13000	141
4	6063-T6	10100	3787.5	.33	1.3 172.8 Table B.4-2	1	30000	25000	25000	19000	141
5	5052-H34	10200	3787.5	.33	1.3 172.8 Table B.4-1	1	34000	26000	24000	20000	141
6	6061-T6 W	10100	3787.5	.33	1.3 172.8 Table B.4-1	1	24000	15000	15000	15000	141
7	6005-T5	10100	3787.5	.33	1.3 172.8 Table B.4-1	1	38000	35000	35000	24000	141

Hot Rolled Steel Section Sets

	Label	Shape	Type	Design List	Material	Design R...	A [in2]	Iyy [in4]	Izz [in4]	J [in4]
1	Post	Pipe 2.0 A21165	Column	Pipe	A572 Gr.50	Typical	.776	.499	.499	.998
2	Cross Beam	Pipe 2.5 A21168	Beam	Wide Flange	A572 Gr.50	Typical	.947	.907	.907	1.814
3	Diagonal Brace	1.5x1.5x0.083	HBrace	SquareTube	A572 Gr.50	Typical	.47	.158	.158	.236



Company : Vector Structural Engineering
 Designer : STB
 Job Number : U2716.091.191
 Model Name : Ground Mount

Apr 12, 2021
 3:07 PM
 Checked By: _____

Aluminum Section Sets

	Label	Shape	Type	Design List	Material	Design R...	A [in2]	Iyy [in4]	Izz [in4]	J [in4]
1	AL Posts	2.375ODX0.188	Column	Pipe	6005-T5	Typical	1.29	.778	.778	1.54
2	AL Brace	RT1.5x2x0.15625	VBrace	Rectangular Tubes	6005-T5	Typical	.996	.327	.524	.602
3	AL Rails	HR300	Beam	Rectangular Tubes	6005-T5	Typical	.74	.253	.727	.578
4	AL Cross Beam	Cross Rail	Beam	Rectangular Tubes	6005-T5	Typical	1.909	1.97	4.366	4.017

Member Area Loads (BLC 2 : Solar Panel Weight)

	Joint A	Joint B	Joint C	Joint D	Direction	Distribution	Magnitude[psf]
1	N197	N200	N199	N196	Y	A-B	-3

Member Area Loads (BLC 3 : Roof Live/Snow)

	Joint A	Joint B	Joint C	Joint D	Direction	Distribution	Magnitude[psf]
1	N197	N200	N199	N196	PY	A-B	-23

Member Area Loads (BLC 4 : Wind A 0 deg)

	Joint A	Joint B	Joint C	Joint D	Direction	Distribution	Magnitude[psf]
1	N197	N200	N201	N198	Perp	A-B	-51.6
2	N198	N201	N199	N196	Perp	A-B	-51.6

Member Area Loads (BLC 5 : Wind B 0 deg)

	Joint A	Joint B	Joint C	Joint D	Direction	Distribution	Magnitude[psf]
1	N197	N200	N201	N198	Perp	A-B	-69.7
2	N198	N201	N199	N196	Perp	A-B	-16.2

Member Area Loads (BLC 6 : Wind A 180 deg)

	Joint A	Joint B	Joint C	Joint D	Direction	Distribution	Magnitude[psf]
1	N197	N200	N201	N198	Perp	A-B	62.1
2	N198	N201	N199	N196	Perp	A-B	60.2

Member Area Loads (BLC 7 : Wind B 180 deg)

	Joint A	Joint B	Joint C	Joint D	Direction	Distribution	Magnitude[psf]
1	N197	N200	N201	N198	Perp	A-B	30.6
2	N198	N201	N199	N196	Perp	A-B	76.4

Member Area Loads (BLC 8 : Wind A 90)

	Joint A	Joint B	Joint C	Joint D	Direction	Distribution	Magnitude[psf]
1	N197	N203	N202	N196	Perp	A-B	22.9
2	N203	N209	N208	N202	Perp	A-B	17.2
3	N209	N200	N199	N208	Perp	A-B	8.6

Member Area Loads (BLC 9 : Wind B 90)

	Joint A	Joint B	Joint C	Joint D	Direction	Distribution	Magnitude[psf]
1	N197	N203	N202	N196	Perp	A-B	-22.9
2	N203	N209	N208	N202	Perp	A-B	-14.3
3	N209	N200	N199	N208	Perp	A-B	-8.6

Basic Load Cases

	BLC Description	Category	X Gravity	Y Gravity	Z Gravity	Joint	Point	Distributed	Area(M...Surface...
1	Self Weight	DL		-1.05					
2	Solar Panel Weight	DL							1



Company : Vector Structural Engineering
 Designer : STB
 Job Number : U2716.091.191
 Model Name : Ground Mount

Apr 12, 2021
 3:07 PM
 Checked By: _____

Basic Load Cases (Continued)

	BLC Description	Category	X Gravity	Y Gravity	Z Gravity	Joint	Point	Distributed	Area(M... Surface...
3	Roof Live/Snow	RLL							1
4	Wind A 0 deg	OL1							2
5	Wind B 0 deg	OL2							2
6	Wind A 180 deg	OL3							2
7	Wind B 180 deg	OL4							2
8	Wind A 90	OL5							3
9	Wind B 90	OL6							3
10	BLC 2 Transient Area ...	None						42	
11	BLC 3 Transient Area ...	None						42	
12	BLC 4 Transient Area ...	None						136	
13	BLC 5 Transient Area ...	None						136	
14	BLC 6 Transient Area ...	None						136	
15	BLC 7 Transient Area ...	None						136	
16	BLC 8 Transient Area ...	None						172	
17	BLC 9 Transient Area ...	None						172	

Load Combinations

	Description	S...	PD...	SRSS	BLC Fa...	BLC Fa...	BLC Fa...	B...	Fa...	B...	Fa...	B...	Fa...	B...	Fa...	B...	Fa...	B...	Fa...	B...	Fa...
1	1.0 D	Yes	Y		DL	1															
2	1.0 D + 1.0 S	Yes	Y		DL	1	RLL	1													
3	1.0 D + 0.6 W1	Yes	Y		DL	1	RLL		OL1	.6											
4	1.0 D + 0.6 W2	Yes	Y		DL	1	RLL		OL2	.6											
5	1.0 D + 0.6 W3	Yes	Y		DL	1	RLL		OL3	.6											
6	1.0 D + 0.6 W4	Yes	Y		DL	1	RLL		OL4	.6											
7	1.0 D + 0.6 W5	Yes	Y		DL	1	RLL		OL5	.6											
8	1.0 D + 0.6 W6	Yes	Y		DL	1	RLL		OL6	.6											
9	1.0 D + 0.45 W1 + 0....	Yes	Y		DL	1	RLL	.75	OL1	.45											
10	1.0 D + 0.45 W2 + 0....	Yes	Y		DL	1	RLL	.75	OL2	.45											
11	1.0 D + 0.45 W3 + 0....	Yes	Y		DL	1	RLL	.75	OL3	.45											
12	1.0 D + 0.45 W4 + 0....	Yes	Y		DL	1	RLL	.75	OL4	.45											
13	1.0 D + 0.45 W5 + 0....	Yes	Y		DL	1	RLL	.75	OL5	.45											
14	1.0 D + 0.45 W6 + 0....	Yes	Y		DL	1	RLL	.75	OL6	.45											
15	0.6 D + 0.6 W1	Yes	Y		DL	.6	RLL		OL1	.6											
16	0.6 D + 0.6 W2	Yes	Y		DL	.6	RLL		OL2	.6											
17	0.6 D + 0.6 W3	Yes	Y		DL	.6	RLL		OL3	.6											
18	0.6 D + 0.6 W4	Yes	Y		DL	.6	RLL		OL4	.6											
19	0.6 D + 0.6 W5	Yes	Y		DL	.6	RLL		OL5	.6											
20	0.6 D + 0.6 W6	Yes	Y		DL	.6	RLL		OL6	.6											
21																					
22	1.4D				DL	1.4															
23	1.2D+1.6SL				DL	1.2	RLL	1.6													
24	1.2D+1.6SL+.5Wx				DL	1.2	RLL	1.6	OL1	.5											
25	1.2D+1.6SL-.5Wx				DL	1.2	RLL	1.6	OL2	.5											
26	1.2D+1.6SL+.5Wz				DL	1.2	RLL	1.6	OL3	.5											
27	1.2D+1.6SL-.5Wz				DL	1.2	RLL	1.6	OL4	.5											
28	1.2D+1.6SL+.5W90				DL	1.2	RLL	1.6	OL5	.5											
29	1.2D+1.6SL-.5W90				DL	1.2	RLL	1.6	OL6	.5											
30	1.2D+1.0Wx				DL	1.2			OL1	1											
31	1.2D-1.0Wx				DL	1.2			OL2	1											
32	1.2D+1.0Wz				DL	1.2			OL3	1											
33	1.2D-1.0Wz				DL	1.2			OL4	1											
34	1.2D+1.0W90				DL	1.2			OL5	1											
35	1.2D-1.0W90				DL	1.2			OL6	1											
36	.9D+1.0Wx				DL	.9			OL1	1											
37	.9D-1.0Wx				DL	.9			OL2	1											



Company : Vector Structural Engineering
 Designer : STB
 Job Number : U2716.091.191
 Model Name : Ground Mount

Apr 12, 2021
 3:07 PM
 Checked By: _____

Load Combinations (Continued)

	Description	S...	PD...	SRSS	BLC	Fa...	BLC	Fa...	BLC	Fa...	B...	Fa...	B...	Fa...	B...	Fa...	B...	Fa...	B...	Fa...	B...	Fa...	B...	Fa...	B...
38	.9D+1.0Wz				DL	.9			OL3	1															
39	.9D-1.0Wz				DL	.9			OL4	1															
40	.9D+1.0W90				DL	.9			OL5	1															
41	.9D-1.0W90				DL	.9			OL6	1															

Envelope Joint Reactions

	Joint		X [lb]	LC	Y [lb]	LC	Z [lb]	LC	MX [lb-ft]	LC	MY [lb-ft]	LC	MZ [lb-ft]	LC
1	N2	max	44.752	12	978.358	10	50.802	3	0	20	0	20	0	20
2		min	-18.627	15	-289.288	17	-59.707	5	0	1	0	1	0	1
3	N1	max	41.339	11	2085.1	5	1113.7...	5	0	20	0	20	0	20
4		min	-46.662	16	-1745.949	16	-940.19	3	0	1	0	1	0	1
5	N132	max	.217	20	2943.303	5	1615.6...	5	0	20	0	20	0	20
6		min	-.087	16	-2443.902	16	-1364....	3	0	1	0	1	0	1
7	N133	max	.353	7	1401.494	10	63.464	3	0	20	0	20	0	20
8		min	-.227	20	-427.661	17	-74.169	5	0	1	0	1	0	1
9	N109	max	3.582	16	3224.826	5	1806.1...	5	0	20	0	20	0	20
10		min	-4.764	11	-2651.098	16	-1524....	3	0	1	0	1	0	1
11	N110A	max	4.506	20	1563.949	10	62.459	3	0	20	0	20	0	20
12		min	-14.181	12	-520.272	17	-72.386	5	0	1	0	1	0	1
13	N121	max	1.283	16	2993.082	5	1646.5...	5	0	20	0	20	0	20
14		min	-1.278	5	-2502.517	16	-1389....	3	0	1	0	1	0	1
15	N122	max	1.525	17	1441.701	10	63.688	3	0	20	0	20	0	20
16		min	-2.918	10	-473.032	17	-74.249	5	0	1	0	1	0	1
17	N133B	max	1.11	8	3072.604	5	1693.2...	5	0	20	0	20	0	20
18		min	-1.007	19	-2570.667	16	-1429....	3	0	1	0	1	0	1
19	N134B	max	3.555	12	1486.766	10	64.479	3	0	20	0	20	0	20
20		min	-2.607	19	-502.208	17	-74.953	5	0	1	0	1	0	1
21	N151	max	.558	16	3063.665	5	1687.8...	5	0	20	0	20	0	20
22		min	-.825	11	-2561.966	16	-1425....	3	0	1	0	1	0	1
23	N152	max	2.501	15	1480.904	10	64.4	3	0	20	0	20	0	20
24		min	-3.712	12	-496.786	17	-74.889	5	0	1	0	1	0	1
25	N157A	max	1.113	5	3002.279	5	1652.6...	5	0	20	0	20	0	20
26		min	-1.116	16	-2511.729	16	-1395....	3	0	1	0	1	0	1
27	N158A	max	2.773	4	1448.11	10	63.78	3	0	20	0	20	0	20
28		min	-2.011	17	-479.823	17	-74.32	5	0	1	0	1	0	1
29	N157	max	46.78	16	2083.9	5	1113.3...	5	0	20	0	20	0	20
30		min	-41.473	11	-1744.782	16	-939.8...	3	0	1	0	1	0	1
31	N158	max	18.383	15	977.538	10	50.784	3	0	20	0	20	0	20
32		min	-44.414	12	-290.399	17	-59.682	5	0	1	0	1	0	1
33	N149	max	4.982	11	3222.786	5	1803.9...	5	0	20	0	20	0	20
34		min	-3.738	16	-2648.553	16	-1522....	3	0	1	0	1	0	1
35	N150	max	14.529	12	1562.096	10	62.436	3	0	20	0	20	0	20
36		min	-4.606	15	-516.271	17	-72.38	5	0	1	0	1	0	1
37	Totals:	max	.006	7	26492.194	11	13496...	17						
38		min	-.005	8	-14474.559	15	-1138...	3						

Envelope AISC 15th(360-16): ASD Steel Code Checks

Member	Shape	Code Check	Loc[in]	LC	Shear	...	Loc[in]	Dir	LC	Pnc/om	[..Pnt/om	[lb]Mnyy/om..	Mnzz/om..	Cb	Eqn
1	M5	Pipe 2.0 A2...	.235	55.424	6	.161	55.424	5	15885.263	23232.186	1397.505	1397.505	1...	H1-1b	
2	M6	Pipe 2.0 A2...	.542	2.466	5	.167	0	5	5356.594	23232.186	1397.505	1397.505	1...	H1-1a	
3	M13	Pipe 2.5 A2...	.432	74.75	12	.187	74.75	5	11641.036	28358.413	2081.747	2081.747	1...	H1-1b	
4	M14	Pipe 2.5 A2...	.451	74.75	11	.182	74.75	11	11641.036	28358.413	2081.747	2081.747	1...	H1-1b	
5	M15	1.5x1.5x0.083	.589	52.42	5	.031	100....	y	11	2344.073	14085.15	624.421	624.421	1...	H1-1a
6	M80	Pipe 2.0 A2...	.254	54.822	17	.229	55.424	5	15885.263	23232.186	1397.505	1397.505	1...	H1-1b	



Envelope AISC 15th(360-16): ASD Steel Code Checks (Continued)

Member	Shape	Code Check	Loc[in]	LC Shear	Loc[in]	Dir	LC Pnc/om	Pnt/om [lb]	Mny/om	Mnz/om	Cb	Eqn			
7	M81	Pipe 2.0 A2...	.772	2.466	5	.245	0	5	5356.594	23232.186	1397.505	1397.505	1...	H1-1a	
8	M82	1.5x1.5x0.083	.848	52.42	5	.002	100....	y	8	2344.073	14085.15	624.421	624.421	1...	H1-1a
9	M50	Pipe 2.0 A2...	.253	54.822	17	.258	55.424	5	15885.263	23232.186	1397.505	1397.505	1...	H1-1b	
10	M51	Pipe 2.0 A2...	.852	2.466	5	.275	0	5	5356.594	23232.186	1397.505	1397.505	1...	H1-1a	
11	M52	1.5x1.5x0.083	.947	52.42	5	.006	0	y	13	2344.073	14085.15	624.421	624.421	1...	H1-1a
12	M56A	Pipe 2.0 A2...	.256	54.822	17	.234	55.424	5	15885.263	23232.186	1397.505	1397.505	1...	H1-1b	
13	M57A	Pipe 2.0 A2...	.786	2.466	5	.249	0	5	5356.594	23232.186	1397.505	1397.505	1...	H1-1a	
14	M58A	1.5x1.5x0.083	.864	52.42	5	.003	100....	y	10	2344.073	14085.15	624.421	624.421	1...	H1-1a
15	M68	Pipe 2.0 A2...	.260	54.822	17	.241	55.424	5	15885.263	23232.186	1397.505	1397.505	1...	H1-1b	
16	M69	Pipe 2.0 A2...	.807	2.466	5	.257	0	5	5356.594	23232.186	1397.505	1397.505	1...	H1-1a	
17	M70	1.5x1.5x0.083	.888	52.42	5	.004	100....	y	5	2344.073	14085.15	624.421	624.421	1...	H1-1a
18	M68A	Pipe 2.5 A2...	.425	71.25	6	.129	131.25	5	11641.036	28358.413	2081.747	2081.747	1...	H1-1b	
19	M69A	Pipe 2.5 A2...	.421	71.479	12	.187	71.479	5	11641.036	28358.413	2081.747	2081.747	1...	H1-1b	
20	M70A	Pipe 2.5 A2...	.473	71.25	11	.150	131.25	11	11641.036	28358.413	2081.747	2081.747	1...	H1-1b	
21	M71	Pipe 2.5 A2...	.438	71.479	11	.182	71.479	11	11641.036	28358.413	2081.747	2081.747	1...	H1-1b	
22	M73	Pipe 2.0 A2...	.259	54.822	17	.240	55.424	5	15885.263	23232.186	1397.505	1397.505	1...	H1-1b	
23	M74	Pipe 2.0 A2...	.805	2.466	5	.256	0	5	5356.594	23232.186	1397.505	1397.505	1...	H1-1a	
24	M75	1.5x1.5x0.083	.886	52.42	5	.005	100....	y	5	2344.073	14085.15	624.421	624.421	1...	H1-1a
25	M76	Pipe 2.0 A2...	.257	54.822	17	.235	55.424	5	15885.263	23232.186	1397.505	1397.505	1...	H1-1b	
26	M77	Pipe 2.0 A2...	.788	2.466	5	.250	0	5	5356.594	23232.186	1397.505	1397.505	1...	H1-1a	
27	M78	1.5x1.5x0.083	.867	52.42	5	.003	0	y	4	2344.073	14085.15	624.421	624.421	1...	H1-1a
28	M76A	Pipe 2.0 A2...	.234	55.424	6	.161	55.424	5	15885.263	23232.186	1397.505	1397.505	1...	H1-1b	
29	M77A	Pipe 2.0 A2...	.541	2.466	5	.167	0	5	5356.594	23232.186	1397.505	1397.505	1...	H1-1a	
30	M78A	1.5x1.5x0.083	.589	52.42	5	.031	100....	y	11	2344.073	14085.15	624.421	624.421	1...	H1-1a
31	M72	Pipe 2.0 A2...	.253	54.822	17	.258	55.424	5	15885.263	23232.186	1397.505	1397.505	1...	H1-1b	
32	M73A	Pipe 2.0 A2...	.851	2.466	5	.274	0	5	5356.594	23232.186	1397.505	1397.505	1...	H1-1a	
33	M74A	1.5x1.5x0.083	.946	52.42	5	.006	0	y	11	2344.073	14085.15	624.421	624.421	1...	H1-1a

Envelope AA ADM1-15: ASD - Building Aluminum Code Checks

Member	Shape	Code C...	Loc[in]	LC Shear	Loc[in]	Dir	LC Pnc/O...	Pnt/Om...	Mny/O...	Mnz/O...	Vny/O...	Vnz/O...	Cb	Eqn			
1	M19	RT1.5x2x...	.059	55.055	11	.008	0	z	6	2164.145	19411....	770.742	927.083	5889.423	3966.346	1...	H.1-1
2	M16	HR300	.708	141.4...	16	.084	141.4...	y	11	3385.295	14429....	560.361	934.132	5656.689	2605.145	1...	H.1-1
3	M75B	RT1.5x2x...	.059	55.123	11	.008	0	z	6	2158.824	19411....	770.742	927.083	5889.423	3966.346	1...	H.1-1
4	M38	HR300	.847	141.4...	16	.087	37.714	y	12	3385.295	14429....	560.361	934.132	5656.689	2605.145	1...	H.1-1
5	M41	HR300	.612	141.4...	16	.085	37.714	y	12	3385.295	14429....	560.361	934.132	5656.689	2605.145	1...	H.1-1
6	M44	HR300	.647	141.4...	16	.086	37.714	y	12	3385.295	14429....	560.361	934.132	5656.689	2605.145	1...	H.1-1
7	M47	HR300	.760	141.4...	16	.085	37.714	y	12	3385.295	14429....	560.361	934.132	5656.689	2605.145	1...	H.1-1
8	M50A	HR300	.719	141.4...	16	.086	37.714	y	12	3385.295	14429....	560.361	934.132	5656.689	2605.145	1...	H.1-1
9	M53	HR300	.710	141.4...	16	.085	37.714	y	12	3385.295	14429....	560.361	934.132	5656.689	2605.145	1...	H.1-1
10	M56	HR300	.774	141.4...	16	.086	37.714	y	12	3385.295	14429....	560.361	934.132	5656.689	2605.145	1...	H.1-1
11	M59	HR300	.630	141.4...	16	.085	37.714	y	12	3385.295	14429....	560.361	934.132	5656.689	2605.145	1...	H.1-1
12	M62	HR300	.624	141.4...	16	.086	37.714	y	12	3385.295	14429....	560.361	934.132	5656.689	2605.145	1...	H.1-1
13	M65	HR300	.838	141.4...	16	.086	37.714	y	12	3385.295	14429....	560.361	934.132	5656.689	2605.145	1...	H.1-1
14	M68B	HR300	.715	141.4...	16	.085	141.4...	y	11	3385.295	14429....	560.361	934.132	5656.689	2605.145	1...	H.1-1
15	M74B	HR300	.559	35.829	6	.078	37.714	y	12	6408.62	14429....	560.361	934.132	5656.689	2605.145	2...	H.1-1
16	M77B	HR300	.688	141.4...	16	.073	141.4...	y	11	3385.295	14429....	560.361	934.132	5656.689	2605.145	1...	H.1-1
17	M80A	HR300	.565	141.4...	16	.073	37.714	y	12	3385.295	14429....	560.361	934.132	5656.689	2605.145	1...	H.1-1
18	M83	HR300	.560	141.4...	16	.073	37.714	y	12	3385.295	14429....	560.361	934.132	5656.689	2605.145	1...	H.1-1
19	M86	HR300	.693	141.4...	16	.073	37.714	y	12	3385.295	14429....	560.361	934.132	5656.689	2605.145	1...	H.1-1
20	M89	HR300	.558	35.829	6	.078	37.714	y	12	6408.62	14429....	560.361	934.132	5656.689	2605.145	2...	H.1-1

NOTES: UNLESS OTHERWISE SPECIFIED
 1. DIMENSIONS SHOWN ARE INCHES [MILIMETERS].

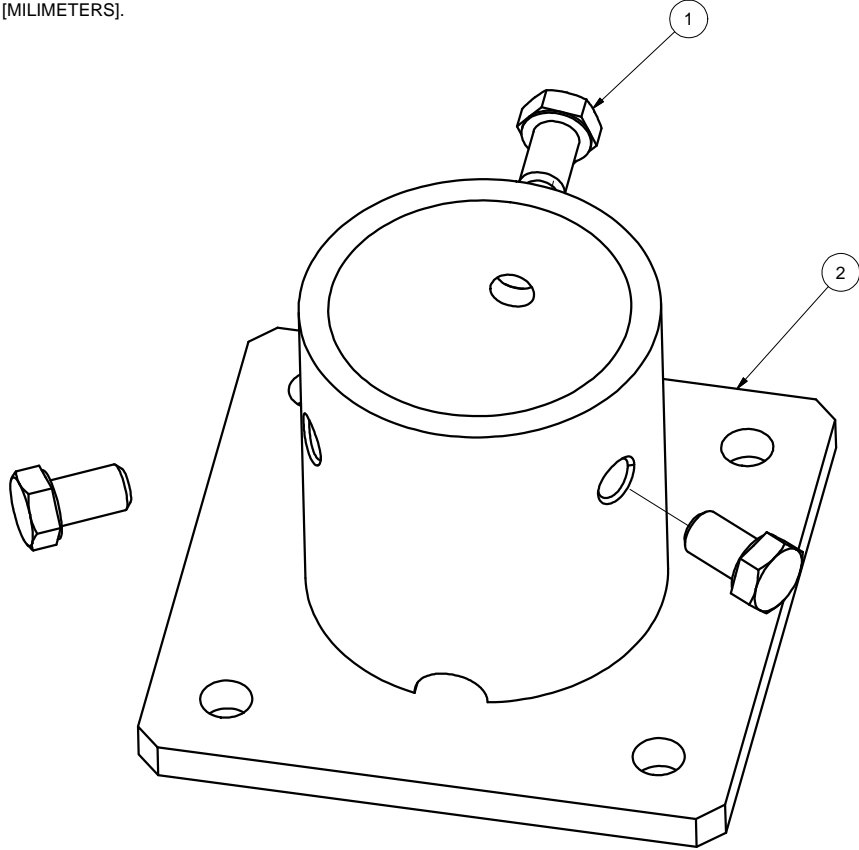

REVISIONS			
REV	DESCRIPTION	BY	DATE
A	INITIAL RELEASE	LWF	10/20/2016

2	A21120-001	2" PIPE BASE	1
1	B15018-011	HEX CAP SCREW 3/8-16 X 5/8	3
ITEM	PART NUMBER	DESCRIPTION	QTY
MATERIAL		SEE NOTES	
Third Angle Projection:			
GENERAL SPECIFICATIONS		Sunmodo Corp. 1905 E 5TH STREET, STE A, VANCOUVER, WA 98661	
Tolerances		TITLE	
X.XXX ±0.01 [0.25mm]		2" PIPE BASE KIT	
X.XX ±0.02 [0.50mm]		DRAWING NUMBER	
X.X ±0.039 [1.0mm]		B K10268-001	
Unless otherwise spec'd		SCALE: NONE	
DRAWN BY		SHEET 1 of 1	
LWF		DATE	
CHECKED BY		10/20/2016	
APPROVALS			

THIS DRAWING IS CONFIDENTIAL PROPERTY OF SUNMODO AND ITS CONTENTS MAY NOT BE DISCLOSED WITHOUT THE PRIOR WRITTEN CONSENT OF SUNMODO CORP.

NOTES: UNLESS OTHERWISE SPECIFIED

1. DIMENSIONS SHOWN ARE INCHES [MILIMETERS].
2. MATERIAL: ALUMINUM 6005-T5.
FINISH: CLEAR ANODIZED 10 μ m THICK.
3. THE UNSPECIFIED DIMENSIONS ARE SPECIFIED BY 2D CAD FILE.

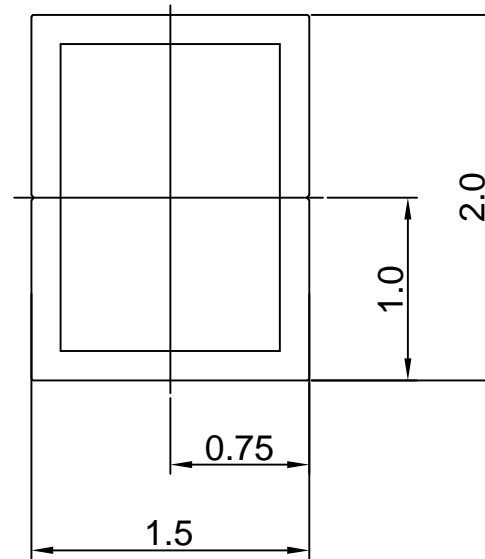

Section properties:

Weight: 1.156 lbs/ft

Area: 0.992 in²

Perimeter: 12.601 in

Bounding Box: X: -1.000,1.000

Y: -0.750, 0.750

Centroid:(0.000,0.000)

Moments of Inertia(in⁴): I_x=0.506,I_y=0.322

Section modulus in bending(in³): W_x=0.675,W_y=0.322

Radii of Gyration: X: 0.714, Y: 0.570

MATERIAL		SEE NOTES	
Third Angle Projection:			
GENERAL SPECIFICATIONS All Dimensions in inches [millimeters] Tolerances X.XXX ± 0.01 [0.25mm] X.XX ± 0.02 [0.50mm] X.X ± 0.039 [1.0mm] Unless otherwise specified.			
DRAWN BY		DATE	
zcg		03/12/2014	
CHECKED BY			
APPROVALS			
		Sunmodo Corp. 1905 E 5TH STREET, SUITE A, VANCOUVER, WA 98661	
		TITLE 1.5X2 AL TUBE BRACE EXTRUSION	
		B DRAWING NUMBER	A20164
		SCALE: NONE	SHEET 1 of 1

REVISIONS			
REV	DESCRIPTION	BY	DATE
A	ADDED BOTTOM CHANNEL & CHANGED ONE 3/8 CHANNEL TO 1/4	zcg	02/21/2013

NOTES: UNLESS OTHERWISE SPECIFIED

1. DIMENSIONS SHOWN ARE INCHES [MILIMETERS].
2. MATERAIL: ALUMINUM 6005-T5.
FINISH: CLEAR ANODIZED 15 μ m THICK.
3. THE UNSPECIFIED DIMENSIONS ARE SPECIFIED BY 2D CAD FILE.

2X 1/4 BOLT SLOT

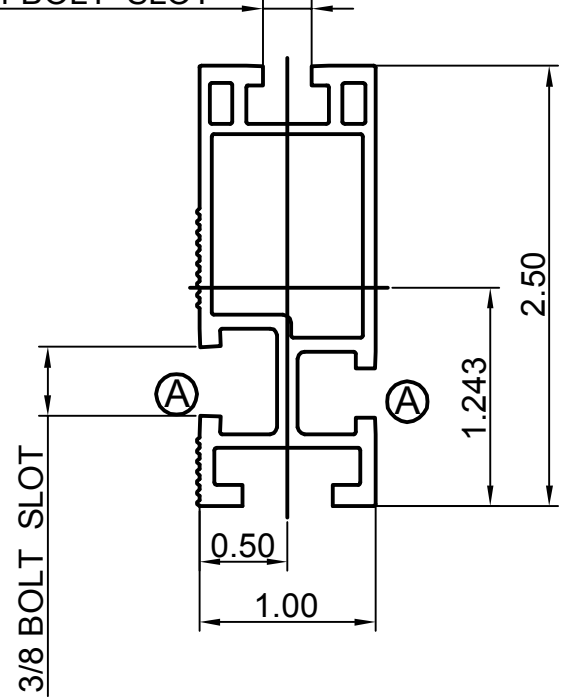

Section properties:

Weight: 0.850 lbs/ft
 Area: 0.723 in²
 Perimeter: 17.325 in
 Bounding Box: X: -0.500,0.500
 Y: -1.243,1.257

Centroid:(0.000,0.000)
 Moments of Inertia(in⁴): I_x=0.486,I_y=0.095
 Section modulus in bending(in³): W_x=0.387,W_y=0.190
 Radii of Gyration: X: 0.820, Y: 0.363

MATERIAL SEE NOTES		Sunmodo Corp.	
Third Angle Projection:			
GENERAL SPECIFICATIONS All Dimensions in inches [millimeters]		1905 E 5TH STREET, SUITE A, VANCOUVER, WA 98661	
Tolerances: X.XXX ± 0.01 [0.25mm] X.XX ± 0.02 [0.50mm] X.X ± 0.039 [1.0mm] Unless otherwise spec'd		TITLE HELIO STANDARD RAIL	
DRAWN BY zcg	DATE 02/21/2013	DRAWING NUMBER A20144	
CHECKED BY		SCALE: NONE SHEET 1 of 1	
APPROVALS			

NOTES: UNLESS OTHERWISE SPECIFIED

1. DIMENSIONS SHOWN ARE INCHES [MILIMETERS].
2. MATERIAL: 6005-T5.
FINISH: CLEAR ANODIZED 10um THICK.
3. THE UNSPECIFIED RADII ARE .02" MAX.
4. THE UNSPECIFIED DIMENSIONS ARE SPECIFIED BY 2D CAD FILE.

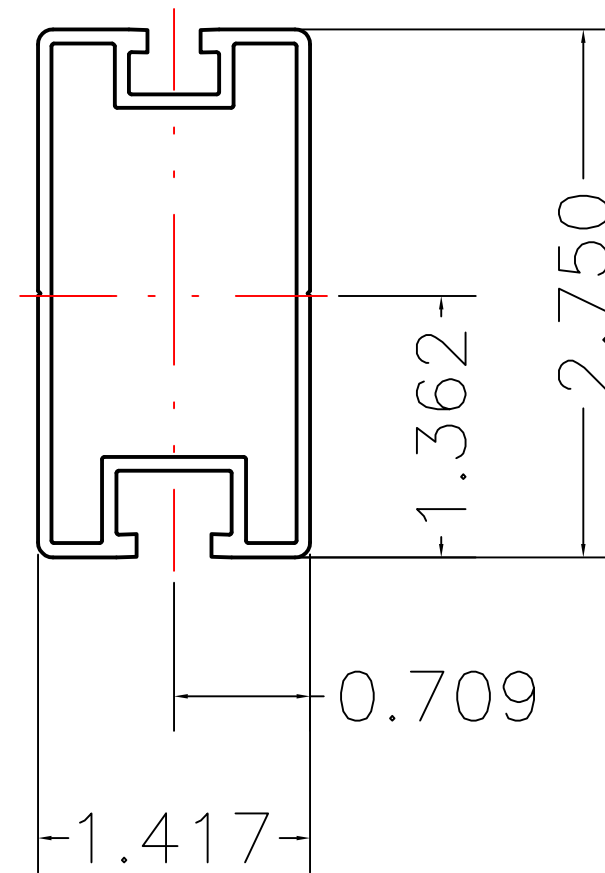

Section properties:

Weight: 0.862 lbs/ft
 Area: 0.736 in²
 Perimeter: 19.824 in
 Bounding Box: X: -0.709,0.709
 Y: -1.362,1.388
 Centroid:(0.000,0.000)
 Moments of Inertia(in⁴): I_x=0.727,I_y=0.214
 Section modulus in bending(in³): W_x=0.524,W_y=0.302
 Radii of Gyration: X: 994, Y: 0.539

THIS DRAWING IS CONFIDENTIAL PROPERTY OF SUNMODO AND ITS CONTENTS MAY NOT BE DISCLOSED WITHOUT THE PRIOR WRITTEN CONSENT OF SUNMODO CORP.

MATERIAL SEE NOTES		SunModo Corp. 14800 NE 65TH STREET, VANCOUVER WA 98682	
Third Angle Projection:			
GENERAL SPECIFICATIONS All Dimensions in inches [millimeters]		TITLE RAIL, HR300 (SUNRAY), EXTRUSION	
Tolerances X.XXX ±0.01 [0.25mm] X.XX ±0.02 [0.50mm] Break all sharp edges X.X ±0.039 [1.0mm] .010-.020 unless Unless otherwise spec'd otherwise specified.			
DRAWN BY KYY	DATE 01/18/2018	B	DRAWING NUMBER A20288
CHECKED BY			
APPROVALS		SCALE: NONE	SHEET 1 of 1

REV	DESCRIPTON	BY	DATE
A	0.44 WAS 0.41, 0.44 WAS 0.33	LWF	11/30/2015

NOTES: UNLESS OTHERWISE SPECIFIED

1. DIMENSIONS SHOWN ARE INCHES [MILIMETERS].
2. MATERIAL: ALUMINUM 6005-T5.
FINISH: CLEAR ANODIZED 15 μm THICK.
3. THE UNSPECIFIED DIMENSIONS ARE SPECIFIED BY 2D CAD FILE.

2X 1/4 BOLT SLOT

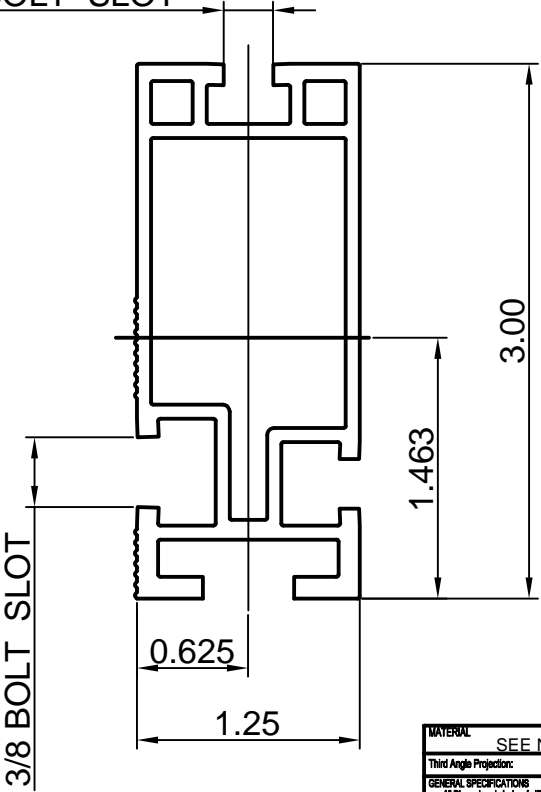

Section properties:

Weight: 1.151 lbs/ft
 Area: 0.980 in²
 Perimeter: 22.104 in
 Bounding Box: X: -0.625,0.625
 Y: -1.463,1.537
 Centroid:(0.000,0.000)
 Moments of Inertia(in⁴): Ix=1.047,Iy=0.207
 Section modulus in bending(in³): Wx=0.681,Wy=0.331
 Radii of Gyration: X: 1.034, Y: 0.460

MATERIAL		SEE NOTES	
Third Angle Projection			
GENERAL SPECIFICATIONS			
All Dimensions in Inches [millimeters]			
Tolerances			
XXXX ±0.01 (0.25mm)			
XX ±0.02 (0.50mm)			
X ±0.03 (1.0mm)			
Unless otherwise specified.			
DRAWN BY		DATE	
ZCJ		02/21/2013	
CHECKED BY		DATE	
APPROVALS		DATE	
Sunmodo Corp.		1905 E 5TH STREET, SUITE A, VANCOUVER, WA 98661	
TITLE		HELIO HEAVY RAIL	
DRAWING NUMBER		A20145	
SCALE:		NONE	
SHEET		1 of 1	

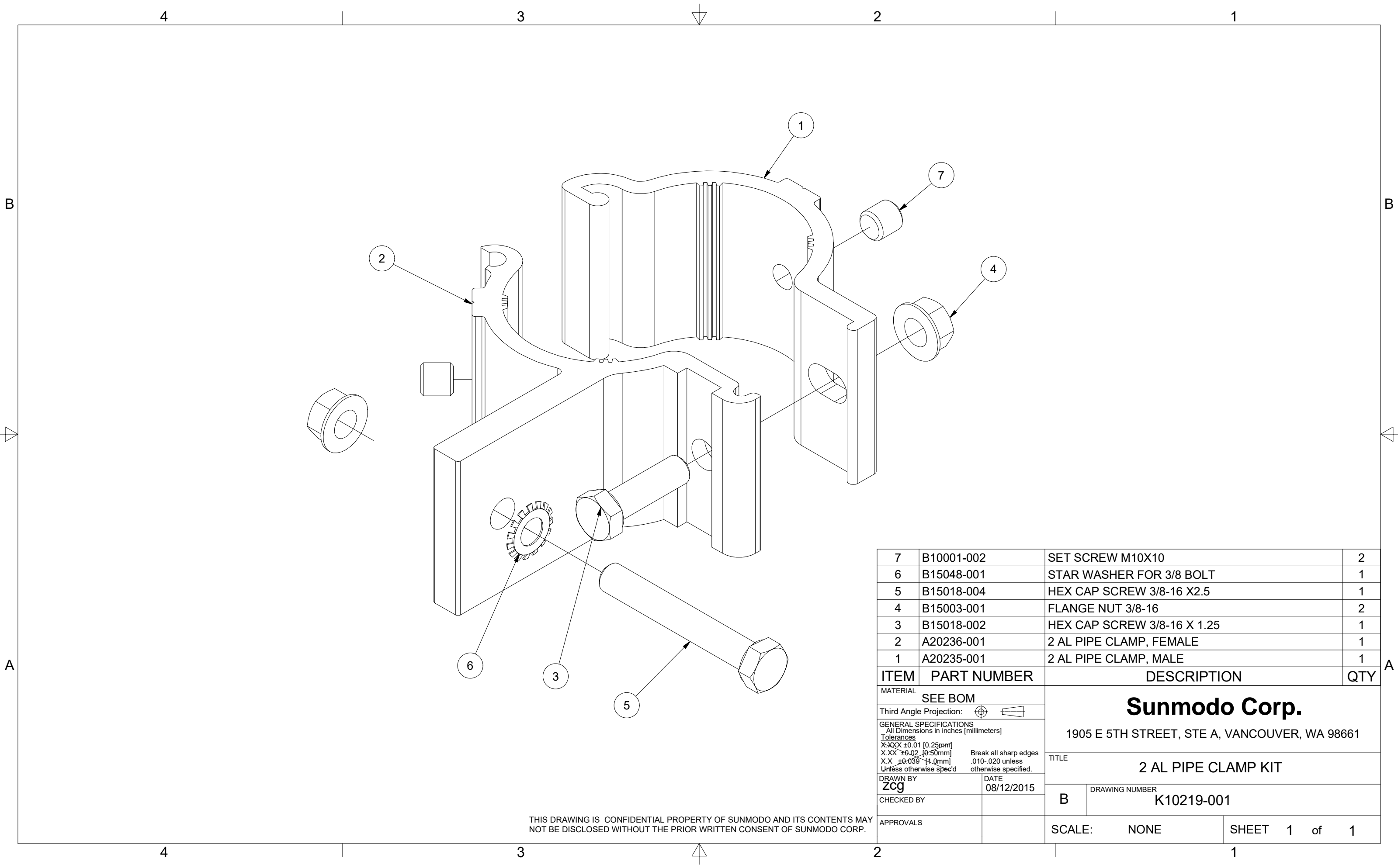

7	B10001-002	SET SCREW M10X10	2
6	B15048-001	STAR WASHER FOR 3/8 BOLT	1
5	B15018-004	HEX CAP SCREW 3/8-16 X2.5	1
4	B15003-001	FLANGE NUT 3/8-16	2
3	B15018-002	HEX CAP SCREW 3/8-16 X 1.25	1
2	A20236-001	2 AL PIPE CLAMP, FEMALE	1
1	A20235-001	2 AL PIPE CLAMP, MALE	1

ITEM	PART NUMBER	DESCRIPTION	QTY
MATERIAL		SEE BOM	
Third Angle Projection:			
GENERAL SPECIFICATIONS All Dimensions in inches (millimeters)			
Tolerances			
X.XXX ±0.01 [0.25mm]		Break all sharp edges	
X.XX ±0.02 [0.50mm]		.010-.020 unless	
X.X ±0.039 [1.0mm]		otherwise specified.	
DRAWN BY		DATE	
zcg		08/12/2015	
CHECKED BY		TITLE	
		2 AL PIPE CLAMP KIT	
APPROVALS		DRAWING NUMBER	
		B K10219-001	
SCALE:		NONE	SHEET 1 of 1

THIS DRAWING IS CONFIDENTIAL PROPERTY OF SUNMODO AND ITS CONTENTS MAY NOT BE DISCLOSED WITHOUT THE PRIOR WRITTEN CONSENT OF SUNMODO CORP.

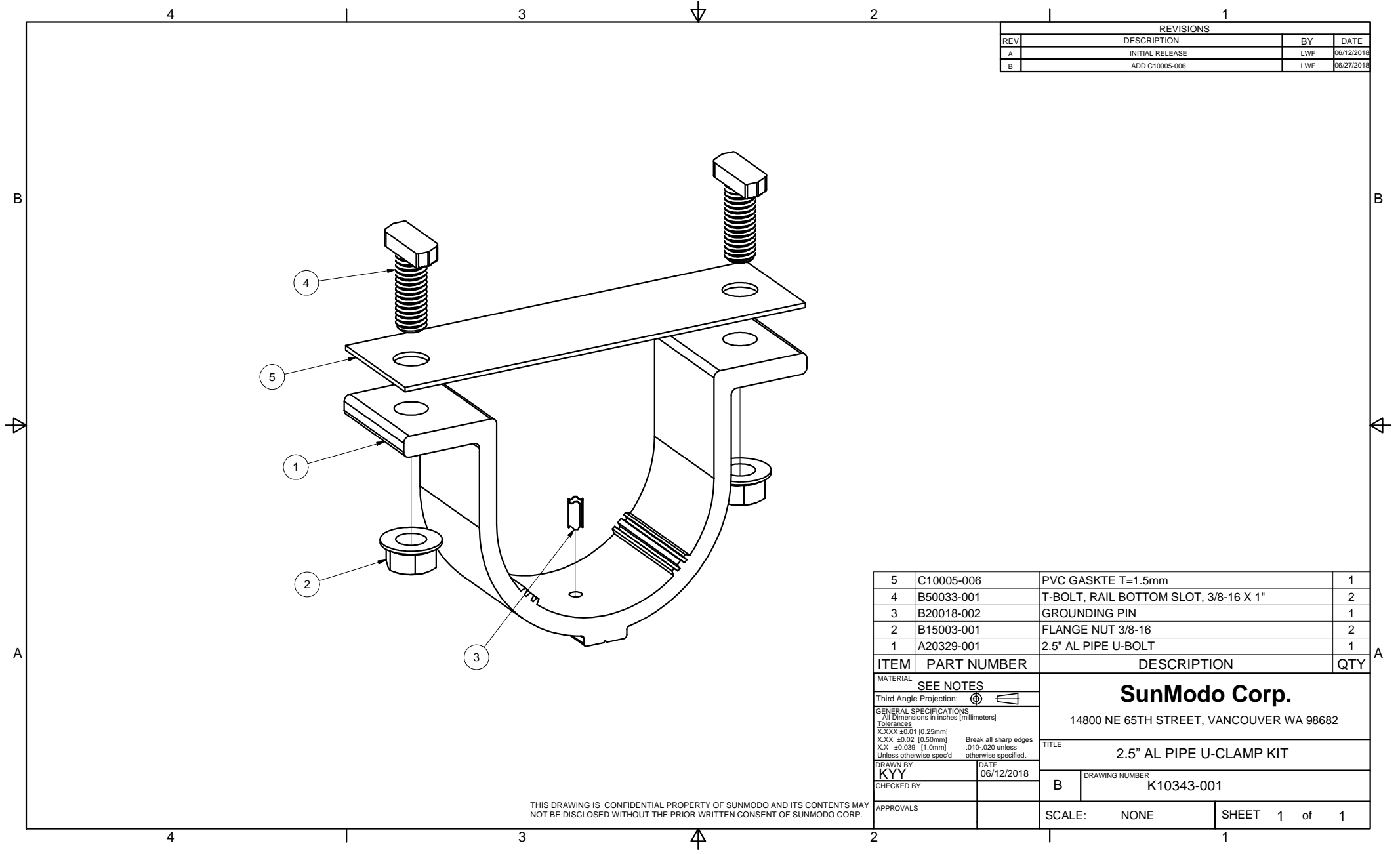

REVISIONS			
REV	DESCRIPTION	BY	DATE
A	INITIAL RELEASE	LWF	06/12/2018
B	ADD C10005-006	LWF	06/27/2018

ITEM	PART NUMBER	DESCRIPTION	QTY
5	C10005-006	PVC GASKTE T=1.5mm	1
4	B50033-001	T-BOLT, RAIL BOTTOM SLOT, 3/8-16 X 1"	2
3	B20018-002	GROUNDING PIN	1
2	B15003-001	FLANGE NUT 3/8-16	2
1	A20329-001	2.5" AL PIPE U-BOLT	1

MATERIAL		SEE NOTES	
Third Angle Projection:			
GENERAL SPECIFICATIONS		<p>SunModo Corp. 14800 NE 65TH STREET, VANCOUVER WA 98682</p>	
All Dimensions in inches [millimeters] Tolerances X.XXX ±0.01 [0.25mm] X.XX ±0.02 [0.50mm] X.X ±0.039 [1.0mm] Unless otherwise spec'd			
TITLE		2.5" AL PIPE U-CLAMP KIT	
DRAWN BY	DATE	DRAWING NUMBER	
KYY	06/12/2018	B K10343-001	
CHECKED BY			
APPROVALS		SCALE: NONE	SHEET 1 of 1

THIS DRAWING IS CONFIDENTIAL PROPERTY OF SUNMODO AND ITS CONTENTS MAY NOT BE DISCLOSED WITHOUT THE PRIOR WRITTEN CONSENT OF SUNMODO CORP.

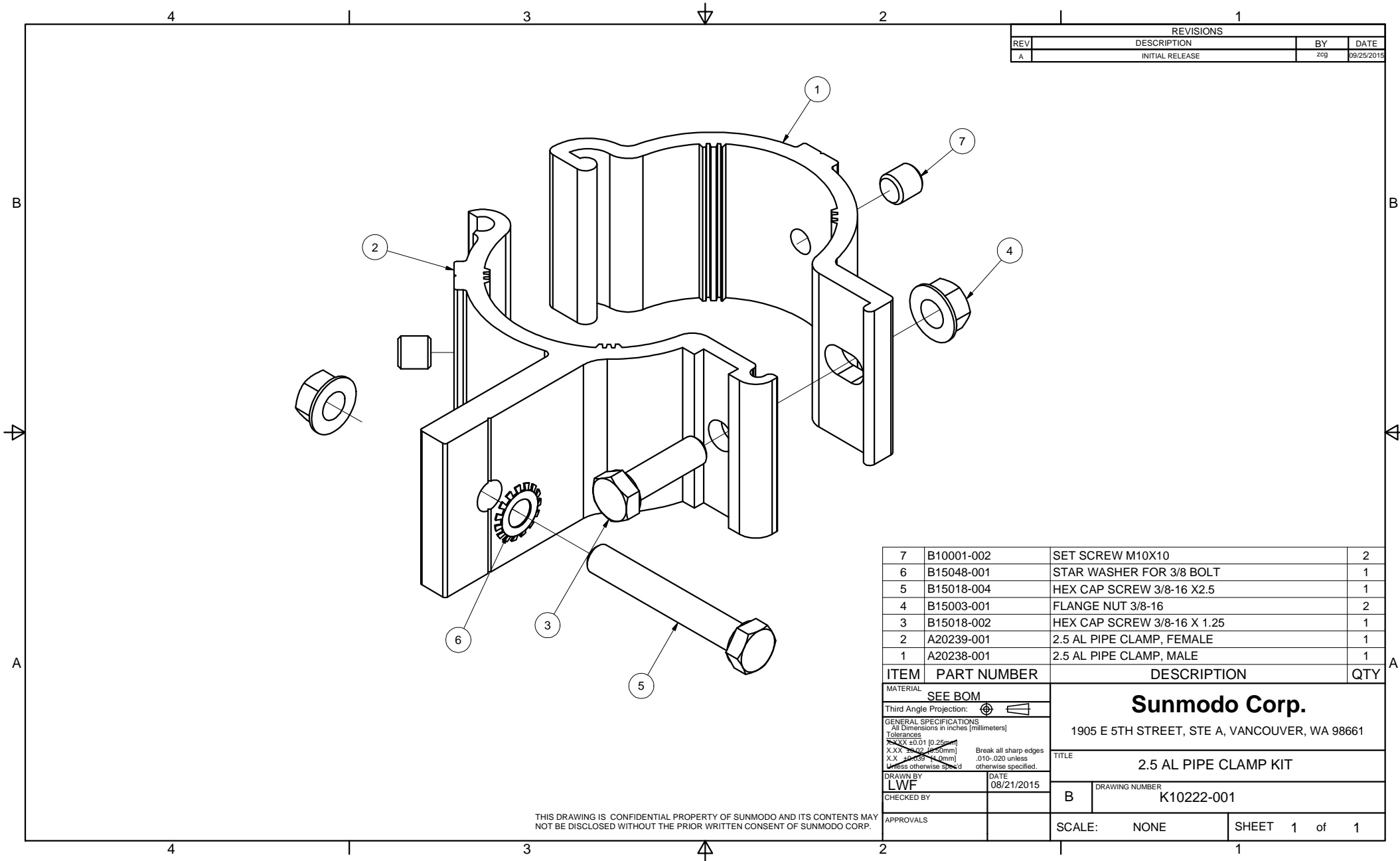

REVISIONS			
REV	DESCRIPTION	BY	DATE
A	INITIAL RELEASE	zcg	09/25/2015

ITEM	PART NUMBER	DESCRIPTION	QTY
7	B10001-002	SET SCREW M10X10	2
6	B15048-001	STAR WASHER FOR 3/8 BOLT	1
5	B15018-004	HEX CAP SCREW 3/8-16 X2.5	1
4	B15003-001	FLANGE NUT 3/8-16	2
3	B15018-002	HEX CAP SCREW 3/8-16 X 1.25	1
2	A20239-001	2.5 AL PIPE CLAMP, FEMALE	1
1	A20238-001	2.5 AL PIPE CLAMP, MALE	1

MATERIAL		SEE BOM	
Third Angle Projection:			
GENERAL SPECIFICATIONS All Dimensions in inches [millimeters] Tolerances X.XX ±0.01 [0.25mm] X.XX ±0.02 [0.50mm] X.X ±0.03 [0.75mm] Unless otherwise specified.			
DRAWN BY		DATE	
LWF		08/21/2015	
CHECKED BY		B	
APPROVALS		SCALE: NONE	
		SHEET 1 of 1	

Sunmodo Corp.
 1905 E 5TH STREET, STE A, VANCOUVER, WA 98661

TITLE: **2.5 AL PIPE CLAMP KIT**

DRAWING NUMBER: **K10222-001**

THIS DRAWING IS CONFIDENTIAL PROPERTY OF SUNMODO AND ITS CONTENTS MAY NOT BE DISCLOSED WITHOUT THE PRIOR WRITTEN CONSENT OF SUNMODO CORP.

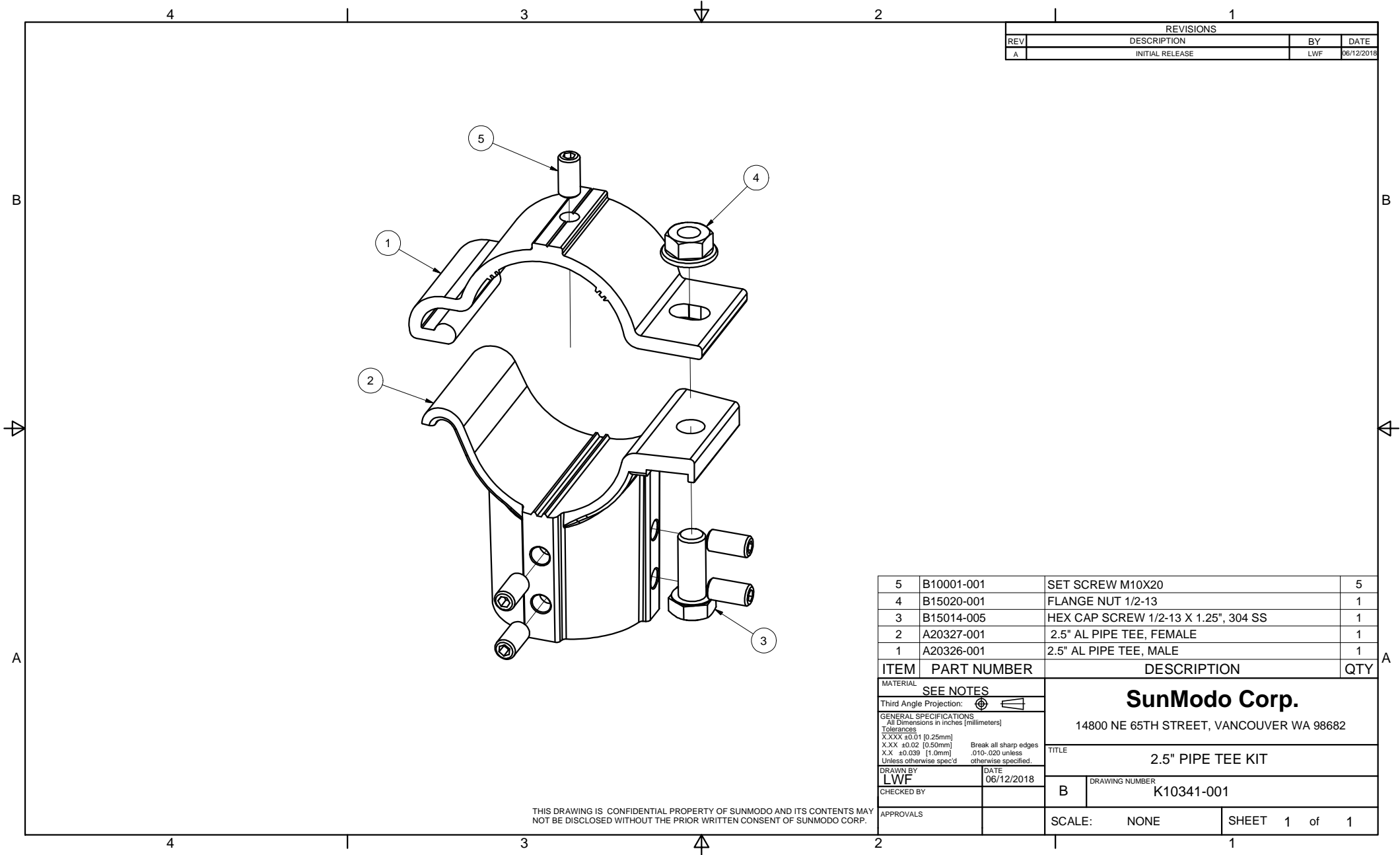

REVISIONS			
REV	DESCRIPTION	BY	DATE
A	INITIAL RELEASE	LWF	06/12/2018

ITEM	PART NUMBER	DESCRIPTION	QTY
5	B10001-001	SET SCREW M10X20	5
4	B15020-001	FLANGE NUT 1/2-13	1
3	B15014-005	HEX CAP SCREW 1/2-13 X 1.25", 304 SS	1
2	A20327-001	2.5" AL PIPE TEE, FEMALE	1
1	A20326-001	2.5" AL PIPE TEE, MALE	1

MATERIAL		SEE NOTES	
Third Angle Projection:			
GENERAL SPECIFICATIONS All Dimensions in inches [millimeters] Tolerances X.XXX ±0.01 [0.25mm] Break all sharp edges X.XX ±0.02 [0.50mm] .010-.020 unless X.X ±0.039 [1.0mm] otherwise specified. Unless otherwise spec'd otherwise specified.			
DRAWN BY	DATE	TITLE	
LWF	06/12/2018	2.5" PIPE TEE KIT	
CHECKED BY		B	DRAWING NUMBER
		K10341-001	
APPROVALS		SCALE:	SHEET 1 of 1
		NONE	

THIS DRAWING IS CONFIDENTIAL PROPERTY OF SUNMODO AND ITS CONTENTS MAY NOT BE DISCLOSED WITHOUT THE PRIOR WRITTEN CONSENT OF SUNMODO CORP.

REVISIONS			
REV	DESCRIPTION	BY	DATE
A	INITIAL RELEASE	LWF	06/12/2018

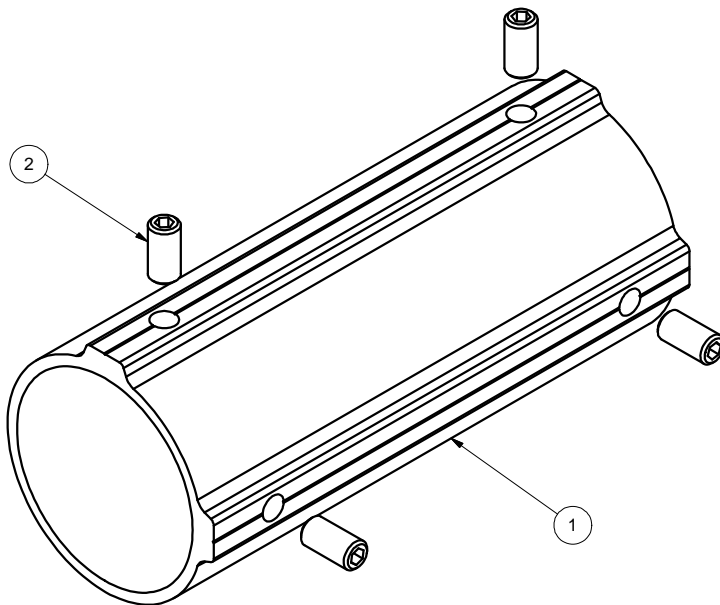

2	B10001-001	SET SCREW M10X20	4
1	A20328-001	2.5" PIPE SPLICE	1
ITEM	PART NUMBER	DESCRIPTION	QTY
MATERIAL		SEE NOTES	
Third Angle Projection:			
GENERAL SPECIFICATIONS		SunModo Corp. 14800 NE 65TH STREET, VANCOUVER WA 98682	
All Dimensions in inches [millimeters] Tolerances X.XXX ±0.01 [0.25mm] X.XX ±0.02 [0.50mm] X.X ±0.039 [1.0mm] Unless otherwise spec'd		Break all sharp edges .010-.020 unless otherwise specified.	
DRAWN BY		TITLE	
LWF		2.5" PIPE SPLICE KIT	
CHECKED BY		DRAWING NUMBER	
		B K10342-001	
APPROVALS		SCALE: NONE SHEET 1 of 1	

THIS DRAWING IS CONFIDENTIAL PROPERTY OF SUNMODO AND ITS CONTENTS MAY NOT BE DISCLOSED WITHOUT THE PRIOR WRITTEN CONSENT OF SUNMODO CORP.

NOTES: UNLESS OTHERWISE SPECIFIED

1. DIMENSIONS SHOWN ARE INCHES [MILIMETERS].
2. MATERIAL:HIGH STRENGTH STEEL PIPE OR TUBE.
3. FINISH: HOT DIP GALVANIZE PER ASTM A123 / A123M - 02.

MINIMUM 50 KSI YIELD STRESS.

4. BREAK ALL BURRS AND SHARP EDGES.

5. ALL WELDING MUST BE IN COMPLIANCE WITH AWS CODE D1;1.

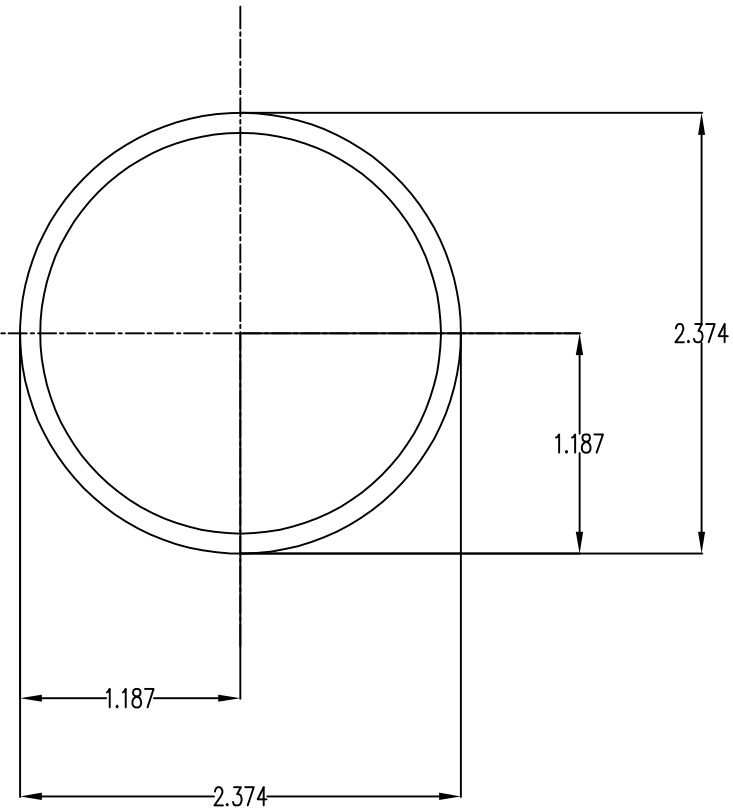

Section properties:

Weight: 2.641 lbs/ft

Area: 0.776 in²

Perimeter: 14.238 in

Bounding Box: X: -1.187,1.187

Y: -1.187,1.187

Centroid:(0.000,0.000)

Moments of Inertia(in⁴): I_x=0.499,I_y=0.499

Section modulus in bending(in³): W_x=0.420,W_y=0.420

Radii of Gyration: X: 0.802, Y: 0.802

MATERIAL		SEE NOTES	
Third Angle Projection:			
GENERAL SPECIFICATIONS			
All Dimensions in Inches (millimeters)			
Tolerances			
XXX ±0.01 (0.25mm)			
XX ±0.02 (0.50mm)			
X ±0.03 (0.75mm)			
Unless otherwise specified			
DRAWN BY		DATE	
LWF		04/03/2019	
CHECKED BY			
APPROVALS			
		TITLE	
		14800 NE 85TH STREET, VANCOUVER WA 98682	
		PIPE, HSS, 2.375" OD X 12 GAUGE,L=XXX	
		DRAWING NUMBER	
		A21165	
		SCALE: NONE	
		SHEET 1 of 1	

NOTES: UNLESS OTHERWISE SPECIFIED

1. DIMENSIONS SHOWN ARE INCHES [MILIMETERS].
2. MATERAIL:HIGH STRENGTH STEEL PIPE OR TUBE.
3. FINISH: HOT DIP GALVANIZE PER ASTM A123 / A123M - 02.

MINIMUM 50 KSI YIELD STRESS.

4. BREAK ALL BURRS AND SHARP EDGES.
5. ALL WELDING MUST BE IN COMPLIANCE WITH AWS CODE D1;1.

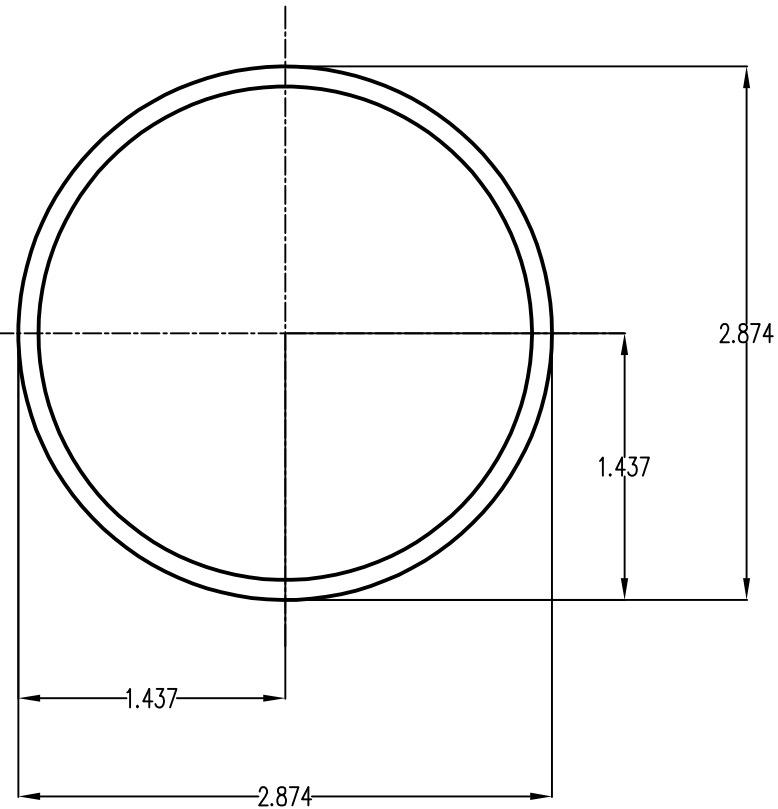

Section properties:

Weight: 3.201 lbs/ft

Area: 0.941 in²

Perimeter: 17.378 in

Bounding Box: X: -1.437,1.437

Y: -1.437,1.437

Centroid:(0.000,0.000)

Moments of Inertia(in⁴): Ix=0.901,Iy=0.901

Section modulus in bending(in³): Wx=0.627,Wy=0.627

Radii of Gyration: X: 0.979, Y: 0.979

MATERIAL		SEE NOTES		Sunmodo Corp. 14800 NE 85TH STREET, VANCOUVER WA 98682	
Third Angle Projection:					
GENERAL SPECIFICATIONS All Dimensions in Inches (millimeters)				TITLE	
Tolerances XXX ±0.01 (0.25mm) XX ±0.02 (0.50mm) X ±0.030 (1.0mm) Unless otherwise specified				PIPE, HSS, 2.875" OD X 12 GAUGE,L=XXX	
DRAWN BY LWF		DATE 04/03/2019		DRAWING NUMBER A21168	
CHECKED BY				B	
APPROVALS				SCALE: NONE SHEET 1 of 1	