



Project Number: U2716-0276-211

May 6, 2022

Sunmodo  
14800 NE 65<sup>th</sup> Street  
Vancouver, WA 98682

**REFERENCE: Sunmodo Sunturf Ground Mount A9 (85x45)  
Ground Mount PV Array Installation**

To Whom It May Concern:

Per request of Sunmodo, we have been asked to prepare the structural design of a ground-mounted PV solar array system with several foundation options as shown in the attached calculations. The adopted building code in this jurisdiction is the International Building Code, 2018 Edition. Vector Structural Engineering requires that we review each site specific install, and we are not liable for installs at site specific locations we have not reviewed. The following design parameters are used in our analysis:

- Minimum Design Loads for Buildings and Other Structures (ASCE 7-16)
- Design wind speed for risk category I structures: 140 mph
- Wind exposure: C
- Ground snow load: 70 psf
- The ground screws and helical piers must be tested to 1.5 times uplift and 2.0 times lateral reactions found in the table below. A minimum of one ground screw or helical pier must be tested.

Load (ASD)	Value (lbs)	Factor of Safety	Test Value (lbs)
UPLIFT	2790	1.5	4185
LATERAL	1783	2	3566

Foundation concrete shall have a minimum compressive strength of 2500 psi at 28 days. Cement for all concrete shall be Type I or II with a minimum of 6% entrained air with a water/cement ratio of 0.50. Maximum aggregate size shall be 3/4". No special inspection of concrete strength is required.

Footings are designed based on an allowable soil bearing pressure of 1500 psf an allowable skin friction of 250 psf, an allowable lateral bearing pressure of 150 pcf, and a coefficient of friction of 0.3. Vector Structural Engineering strongly recommends independent soils testing be performed by a licensed geotechnical engineer to verify the assumed soil parameters.

All ground mounts are to be installed per manufacturer’s recommendations. The use of solar panel support span tables provided by the manufacturer is allowed only where the site conditions and solar panel configuration match the description of the span tables. Electrical engineering is beyond our scope. All work performed must be in accordance with accepted industry-wide methods and applicable safety standards. Vector Structural Engineering assumes no responsibility for improper installation of the solar panels.

Very truly yours,

VECTOR STRUCTURAL ENGINEERING, LLC

\_\_\_\_\_  
Jacob Proctor, P.E.  
CA License: 70567  
Project Engineer

Enclosures

JSP/stb



05/06/2022

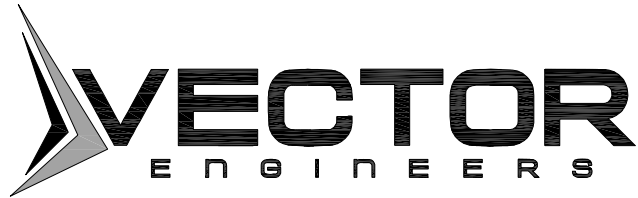

JOB NO. U2716-0276-211  
 PROJECT SUNMODO SUNTURF GROUND MOUNTS A9  
 SUBJECT ALL OPTIONS

651 W GALENA PARK BLVD. #101 (801) 990-1775  
 DRAPER, UTAH 84020 (801) 990-1776 FAX

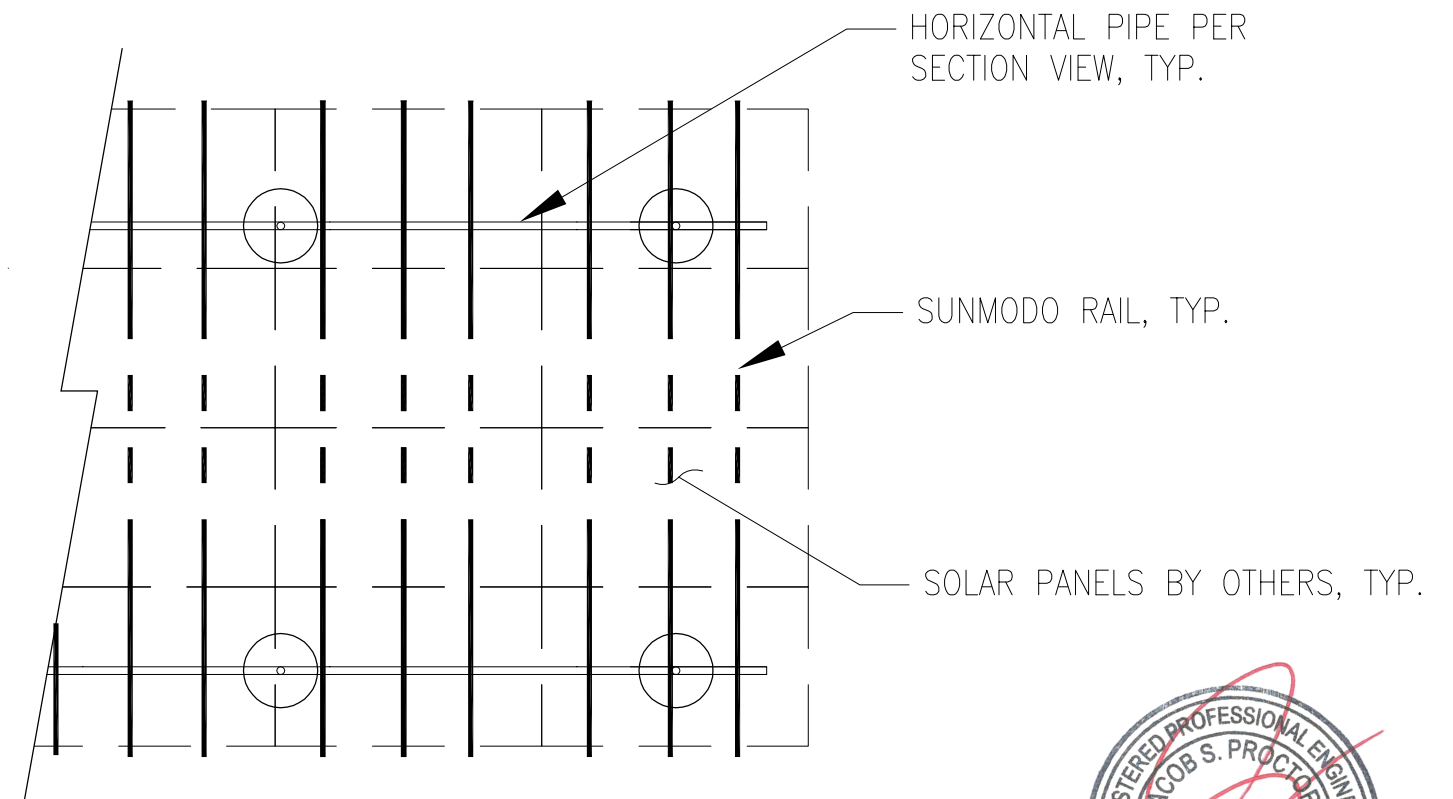
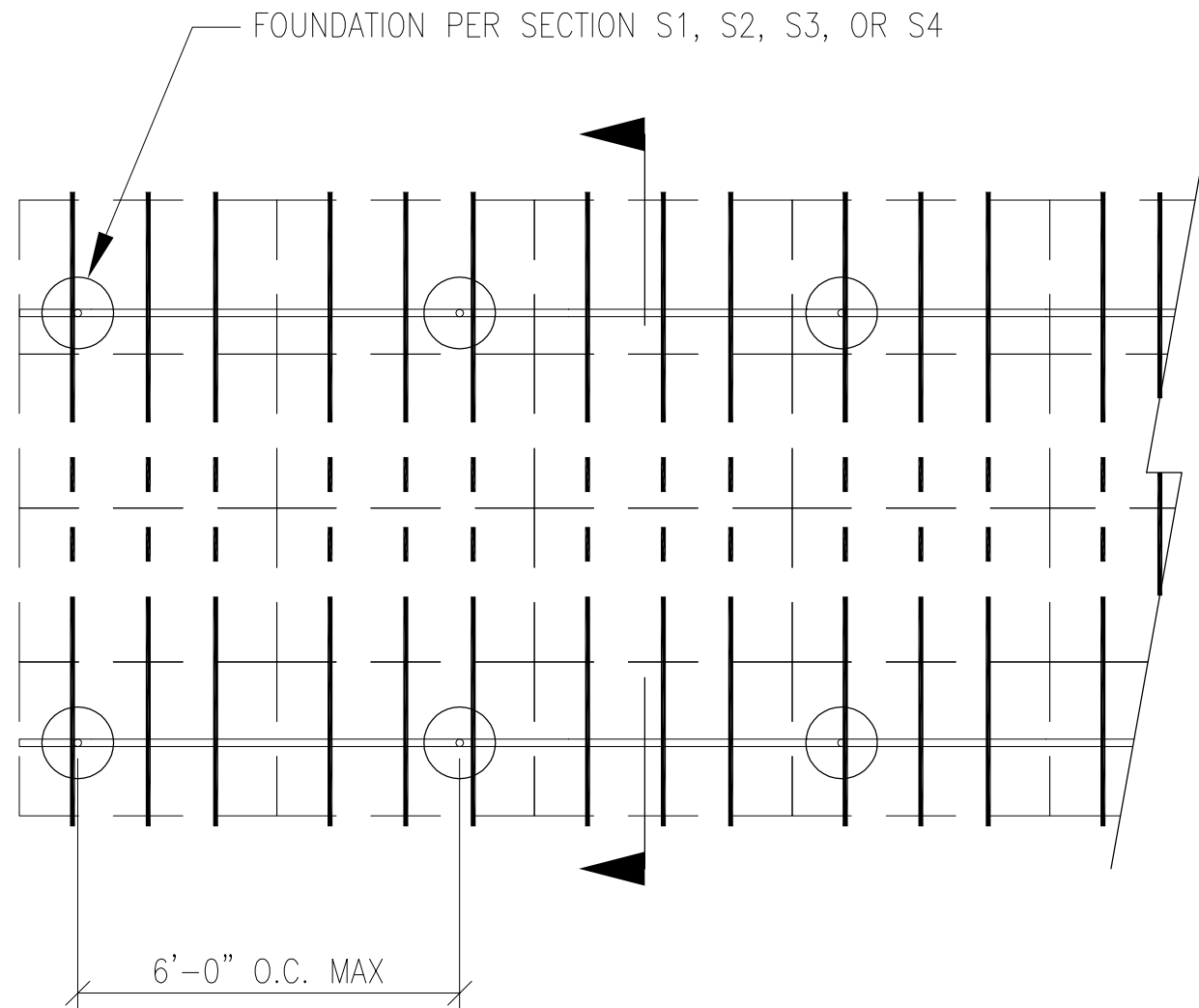

05/06/2022

**PV ARRAY PLAN**

N.T.S.

**P1**

Vector Engineers requires that we review each site specific install and is not liable for installs at site specific locations we have not reviewed.

PROJECT SUNMODO SUNTURF GROUND MOUNTS A9

SUBJECT DRILLED PIER OPTION

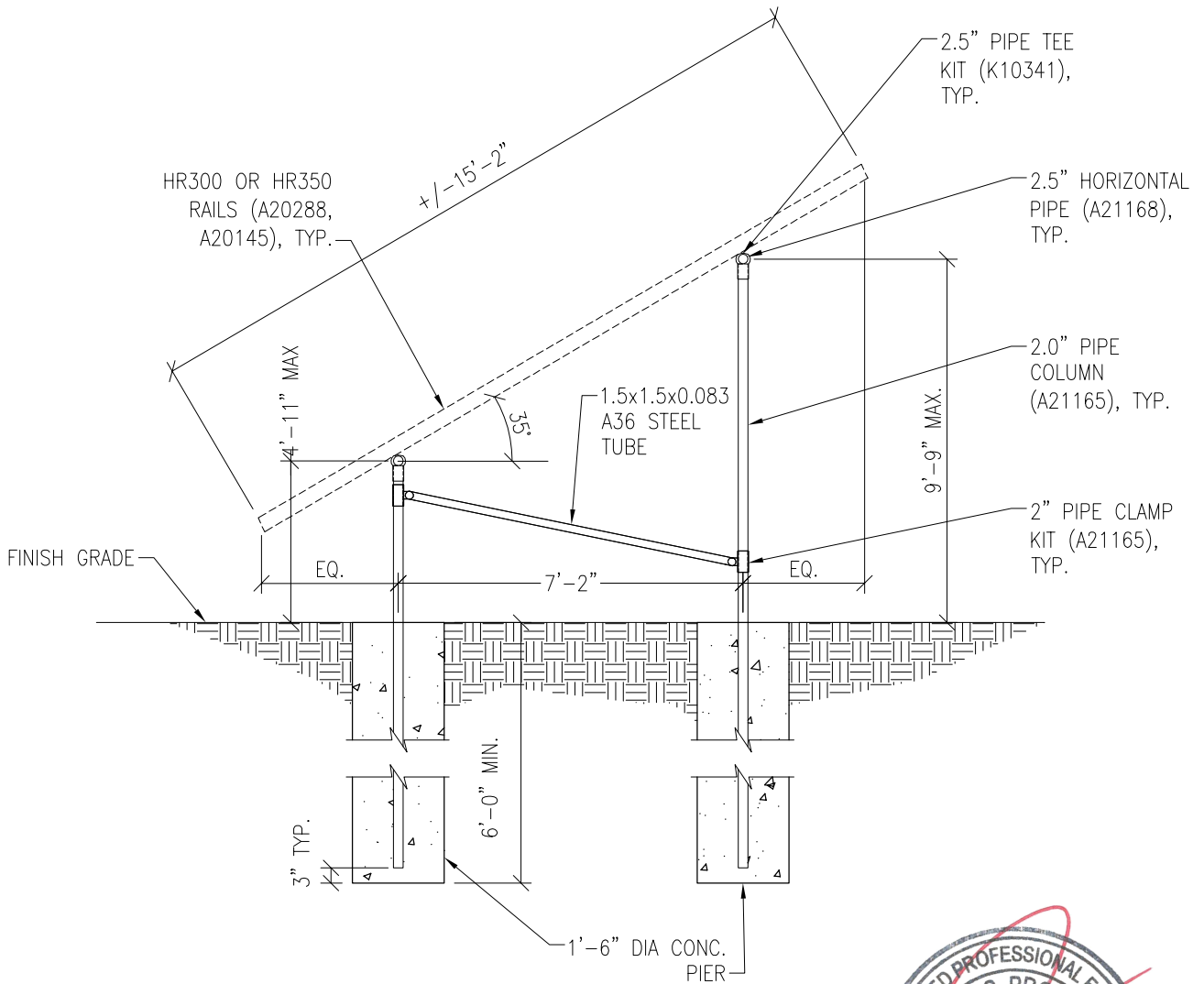

Vector Engineers requires that we review each site specific install and is not liable for installs at site specific locations we have not reviewed.

**PV ARRAY SECTION**

N.T.S.

05/06/2022

**S1**

PROJECT SUNMODO SUNTURF GROUND MOUNTS A9

SUBJECT HELICAL PIER OPTION

**NOTES:**

1. For ground mount components see Section S1.
2. A minimum of (1) helical pier must be load-tested as follows:
  - 2.1. Safety factor for uplift = 1.5,
  - 2.2. Safety factor for lateral loads = 2.0
  - 2.3. Upward deflection limit = 1/2"
  - 2.4. Lateral deflection limit = 1"
  - 2.5. The load tests must be performed by an approved contractor.

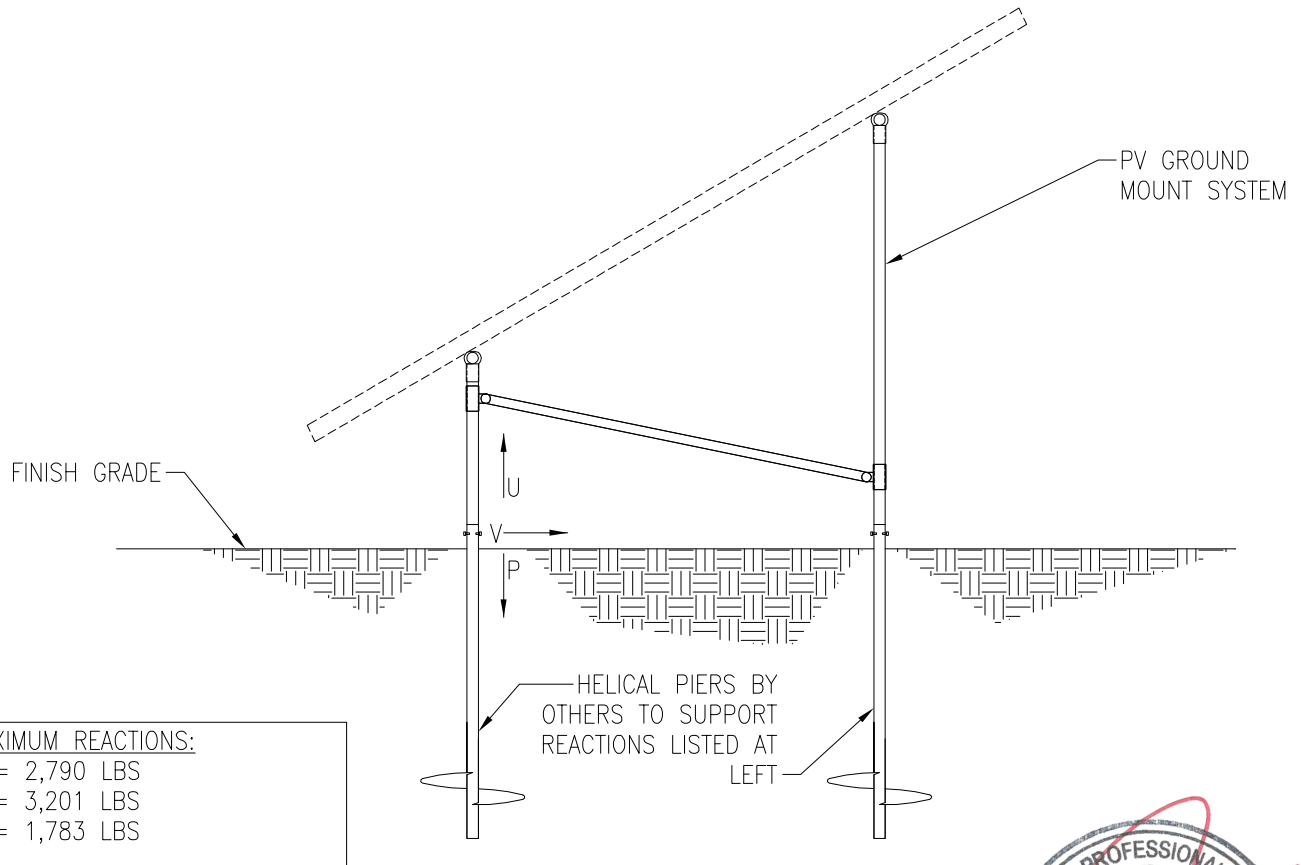

**MAXIMUM REACTIONS:**  
 U = 2,790 LBS  
 P = 3,201 LBS  
 V = 1,783 LBS



Vector Engineers requires that we review each site specific install and is not liable for installs at site specific locations we have not reviewed.

**PV ARRAY SECTION**

N.T.S.

05/06/2022

**S2**



JOB NO. U2716-0276-211

PROJECT SUNMODO SUNTURF GROUND MOUNTS A9

SUBJECT GROUND SCREW OPTION

NOTES:

- 1. For ground mount components see Section S1.
- 2. A minimum of (1) ground screw must be load-tested as follows:
  - 2.1. Safety factor for uplift = 1.5,
  - 2.2. Safety factor for lateral loads = 2.0
  - 2.3. Upward deflection limit = 1/2"
  - 2.4. Lateral deflection limit = 1"
  - 2.5. The load tests must be performed by an approved contractor.

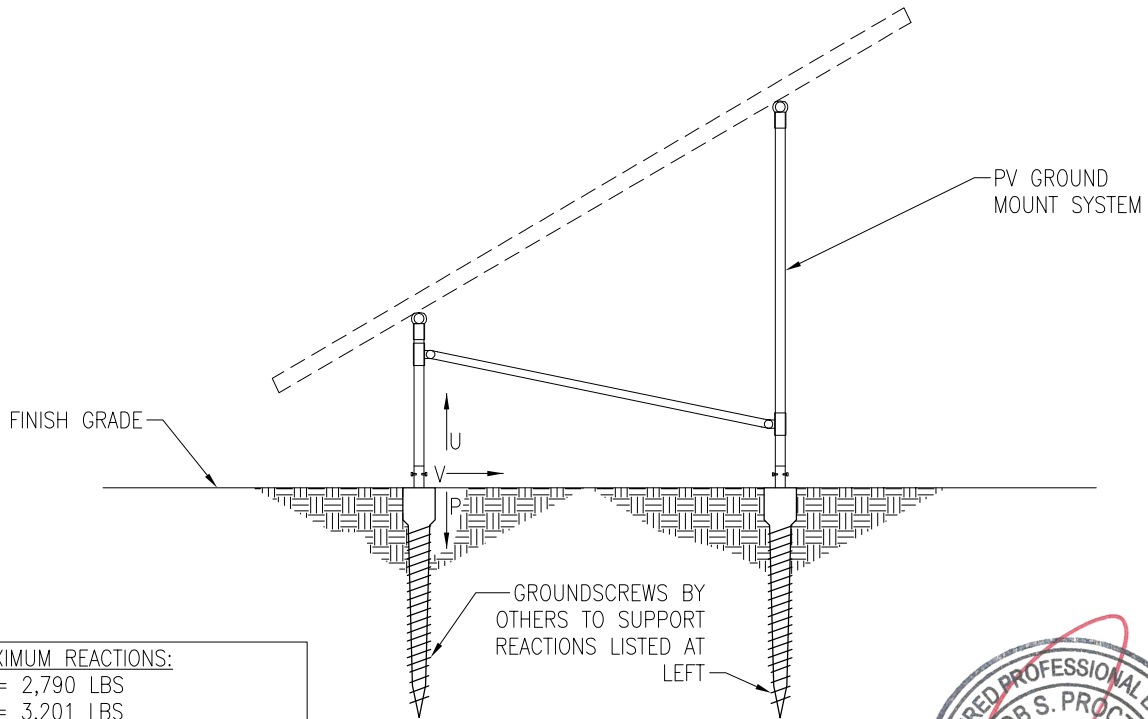

MAXIMUM REACTIONS:  
 U = 2,790 LBS  
 P = 3,201 LBS  
 V = 1,783 LBS



Vector Engineers requires that we review each site specific install and is not liable for installs at site specific locations we have not reviewed.

PV ARRAY SECTION

N.T.S.

S3

651 W GALENA PARK BLVD. #101  
DRAPER, UTAH 84020

(801) 990-1775  
(801) 990-1776 FAX

05/06/2022

WWW.VECTORSE.COM



JOB NO. U2716-0276-211

PROJECT SUNMODO SUNTURF GROUND MOUNTS A9

SUBJECT BALLASTED BLOCK OPTION

**NOTES:**

1. For ground mount components see Section S1.

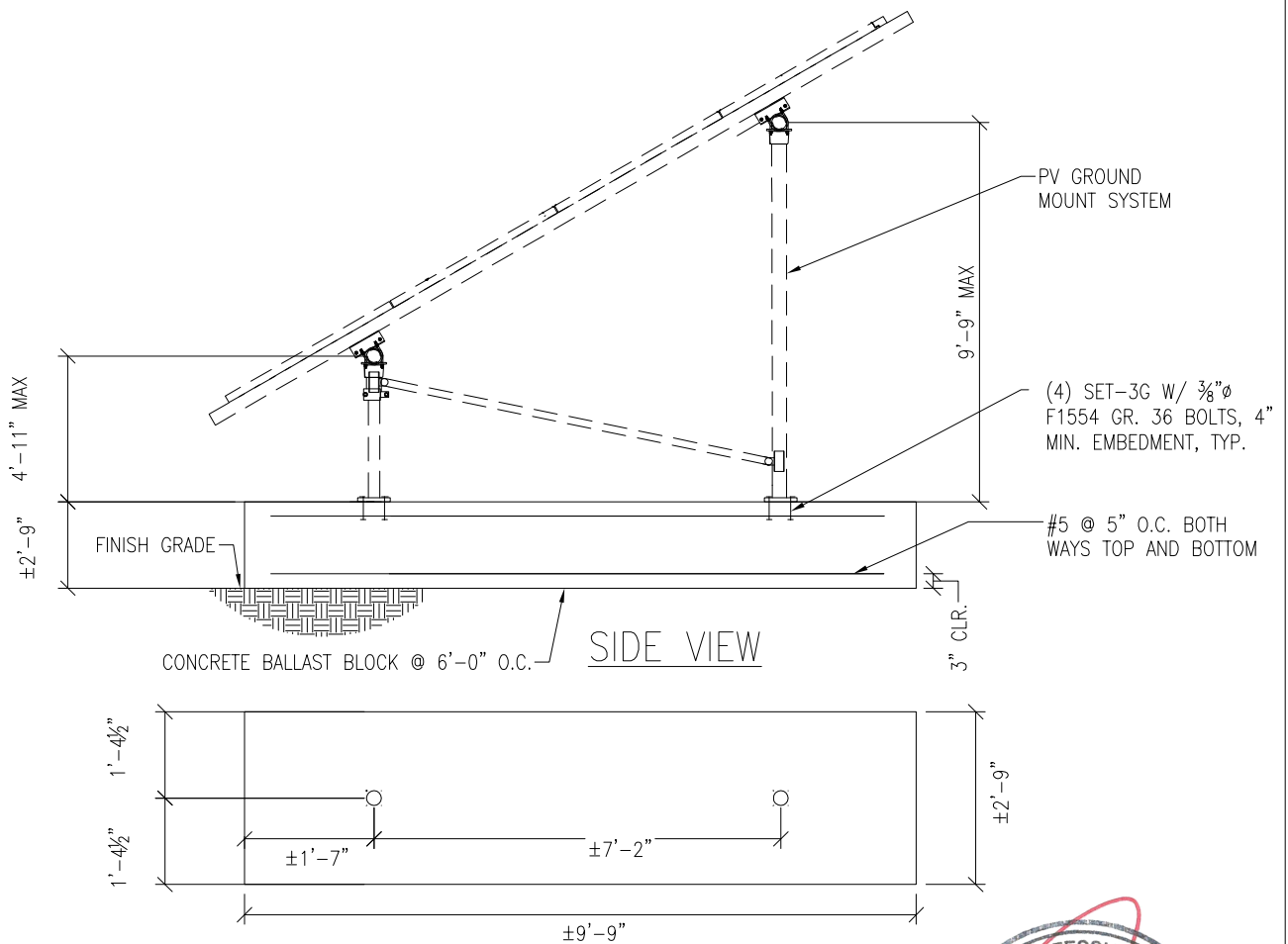

Vector Engineers requires that we review each site specific install and is not liable for installs at site specific locations we have not reviewed.

**PV ARRAY SECTION**

N.T.S.



**S4**

651 W GALENA PARK BLVD. #101  
 DRAPER, UTAH 84020

(801) 990-1775  
 (801) 990-1776 FAX

05/06/2022

WWW.VECTORSE.COM



**JOB NO.:** U2716.0276.211  
**SUBJECT:** SNOW LOADS

**PROJECT:** Sunturf Package A9 Ground Mount

**SNOW LOADS**

Calculations Per:	ASCE 7-16	
Snow Ground Load, $p_g$ [psf]:	70.0	(Section 7.2)
Risk Category:	I	(Table 1.5-1)
Importance Factor, $I_s$ :	0.8	(Table 1.5-2)
Terrain Category:	C	(Section 26.7)
Exposure of Roof:	Fully Exposed	(Table 7-3.1)
Exposure Factor, $C_e$ :	0.9	(Table 7-3.1)
Thermal Factor, $C_t$ :	1.2	(Table 7-3.2)
Flat Roof Snow Load, $p_f$ [psf]:	42	(Equation 7.3-1)
Min. Roof Snow Load, $p_m$ [psf]:	0	(Section 7.3.4)
Panel Slope from Horizontal [°]:	35.0	
Unobstructed Slippery Surface?	Yes	(Section 7.4)
Slope Factor Figure:	Figure 7-2c	(of Figure 7.4-1 - See Section 7.4)
Roof Slope Factor, $C_s$ :	0.64	
Sloped Roof Snow Load, $p_s$ [psf]:	27	(Equation 7.4-1)
Design Snow Load, $S$ [psf]:	27	(1.0 Snow)



**PROJECT:** Sunturf Package A9 Ground Mount

**WIND PRESSURES**

Calculations per:	ASCE 7-16	
Design Wind Speed, V [mph]:	140	
Risk Category:	I	(Table 1.5-1)
Exposure Category:	C	(Section 26.7)
Elevation [ft]:	9.2	
Ground Elevation Factor, $K_e$ :	1.00	(Table 26.9-1)
$\alpha$ :	9.5	(Table 26.11-1)
$z_g$ [ft]:	900	(Table 26.11-1)
Velocity Pressure Exposure Coefficient, $K_h$ :	0.85	(Table 26.10-1)
Topographic Factor, $K_{ht}$ :	1.0	(Section 26.8)
Wind Directionality Factor, $K_d$ :	0.85	(Table 26.6-1)
Internal Pressure Coefficient, $GC_{pi}$ :	0.00	(Figure 26.13-1)
Velocity Pressure, $q_h$ [psf]:	36.19	(Equation 26.10-1)
Gust Effect Factor, G:	0.85	(Section 26.11.4)
Panel Slope [degrees]:	35.0	
Wind Flow:	Clear	
Roof Configuration:	Monoslope	

Wind Pressures in Transverse (N-S) Direction

Net Pressure Coefficients per Figure 27.3-4

Clear Wind Flow	$C_{NW}$	$C_{NL}$
Case 1 ( $\gamma = 0^\circ$ , Load Case A)	-1.8	-1.8
Case 2 ( $\gamma = 0^\circ$ , Load Case B)	-2.4	-0.6
Case 3 ( $\gamma = 180^\circ$ , Load Case A)	2.1	2.1
Case 4 ( $\gamma = 180^\circ$ , Load Case B)	2.7	1.1

Design Wind Pressures per Equation 27.3-2 [psf]

Clear Wind Flow	$q_h GC_{NW}$	$q_h GC_{NL}$
Case 1 ( $\gamma = 0^\circ$ , Load Case A)	-55.4	-55.4
Case 2 ( $\gamma = 0^\circ$ , Load Case B)	-73.8	-18.5
Case 3 ( $\gamma = 180^\circ$ , Load Case A)	64.6	64.6
Case 4 ( $\gamma = 180^\circ$ , Load Case B)	83.1	33.8
Case 5 ( $\gamma = 0^\circ$ , 16 psf Min. Horiz.)	-16.0	-16.0
Case 6 ( $\gamma = 180^\circ$ , 16 psf Min. Horiz.)	16.0	16.0



JOB NO.: U2716-0276-211

DESIGNED: STB

---

# Foundation Option 1: Drilled Concrete Pier



PROJECT: Sunturf Package A9 Ground Mount

**DRILLED CONCRETE PIER DESIGN**

**Column Reactions:**

Max. Shear, V [k]:	1.8	Max. Down, P <sub>d</sub> [k]:	3.2
Max. Moment, M [k-ft]:	0.0	Max. Uplift, P <sub>u</sub> [k]:	2.8

**Pier Properties:**

Pier Shape:	Round	Volume of Concrete [ft <sup>3</sup> ]:	11
Pier Diameter, b [ft]:	1.5	Volume of Concrete [yd <sup>3</sup> ]:	0.4
Top of Pier Elevation [ft]:	0.00	Weight of Concrete [k]:	1.6
Pier Depth, d [ft]:	6.0		

**Soil Properties:**

Allow. Bearing Pressure [psf]:	1,500	<u>Optional Parameters for Uplift:</u>	
1/3 increase for short term loads?	No		
Lateral Bearing, S [pcf]:	150	Skin Friction* [psf]:	250
Max. Lateral Bearing (opt'l) [psf]:		Top Length to Ignore [ft]:	0
Top Depth to Ignore [ft]:	0	1/3 increase for short term loads?	No
1/3 increase for short term loads?	No	Combine w/ Bearing:	No
1/2" deflection at t/o pier allowed:	Yes		

\*per IBC Section 1810.3.3.1.4

**Check Bearing:**

Bearing Capacity [k]:	7.1
-----------------------	-----

**Bearing capacity OK.**

**Check Uplift:**

Uplift Capacity [k]:	8.5
----------------------	-----

**Uplift capacity OK.**

**Check Lateral Bearing:**

Top of Pier Constrained?:	No	IBC Section 1807.3.2.1
Applied Lateral Force, P [lb]:	1,783	
Point of Application, h [ft]:	0.0	
S <sub>max</sub> [psf]:		
S [psf]:	600	
A = 2.34*P/(S <sub>b</sub> ):	4.64	
Required Pier Depth, d <sub>reqd</sub> [ft]:	4.60	IBC Eq. 18-1

Result: **Lateral bearing capacity OK.**

# Foundation Option 2: Helical Pier

The ground screws and helical piers must be tested to 1.5 times uplift and 2.0 times lateral reactions found in the table below.

Load (ASD)	Value (lbs)	Factor of Safety	Test Value (lbs)
UPLIFT	2790	1.5	4185
LATERAL	1783	2	3566

# Foundation Option 3: Ground Screw

The ground screws and helical piers must be tested to 1.5 times uplift and 2.0 times lateral reactions found in the table below.

Load (ASD)	Value (lbs)	Factor of Safety	Test Value (lbs)
UPLIFT	2790	1.5	4185
LATERAL	1783	2	3566



JOB NO.: U2716-0276-211

DESIGNED: STB

---

# Foundation Option 4: Ballasted Block

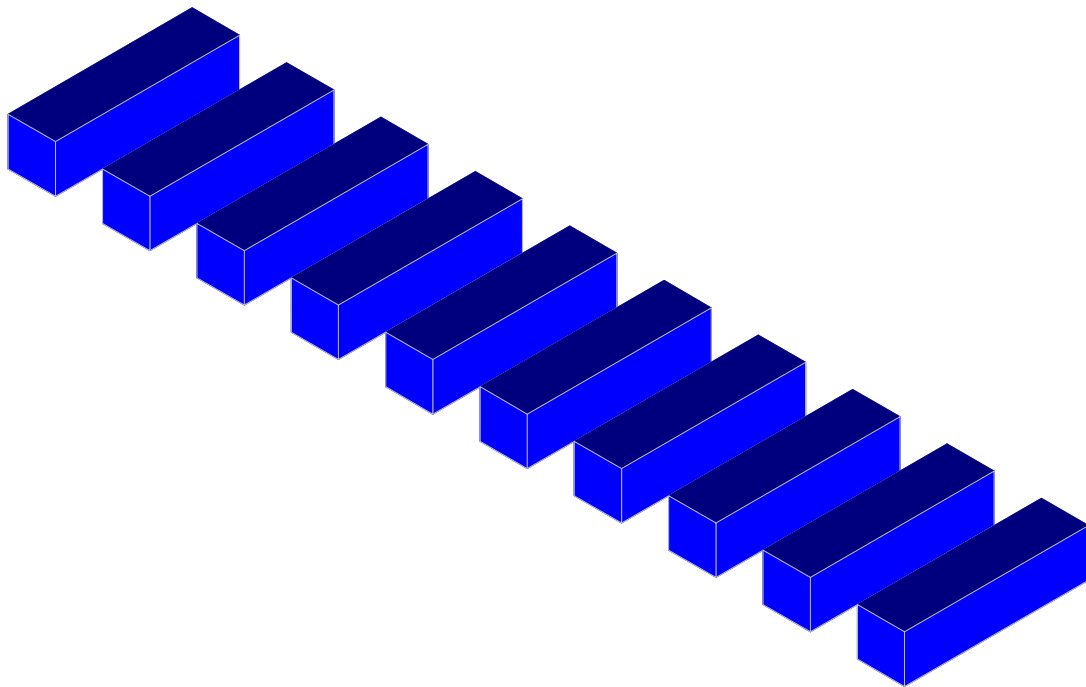

Results for LC 1, 1.0 D

Vector Structural Engineeri..	Ground Mount	SK - 2
STB		Mar 30, 2021 at 4:30 PM
U2716.115.191		Sunmodo Sunturf A9 v3 85x45.r3d

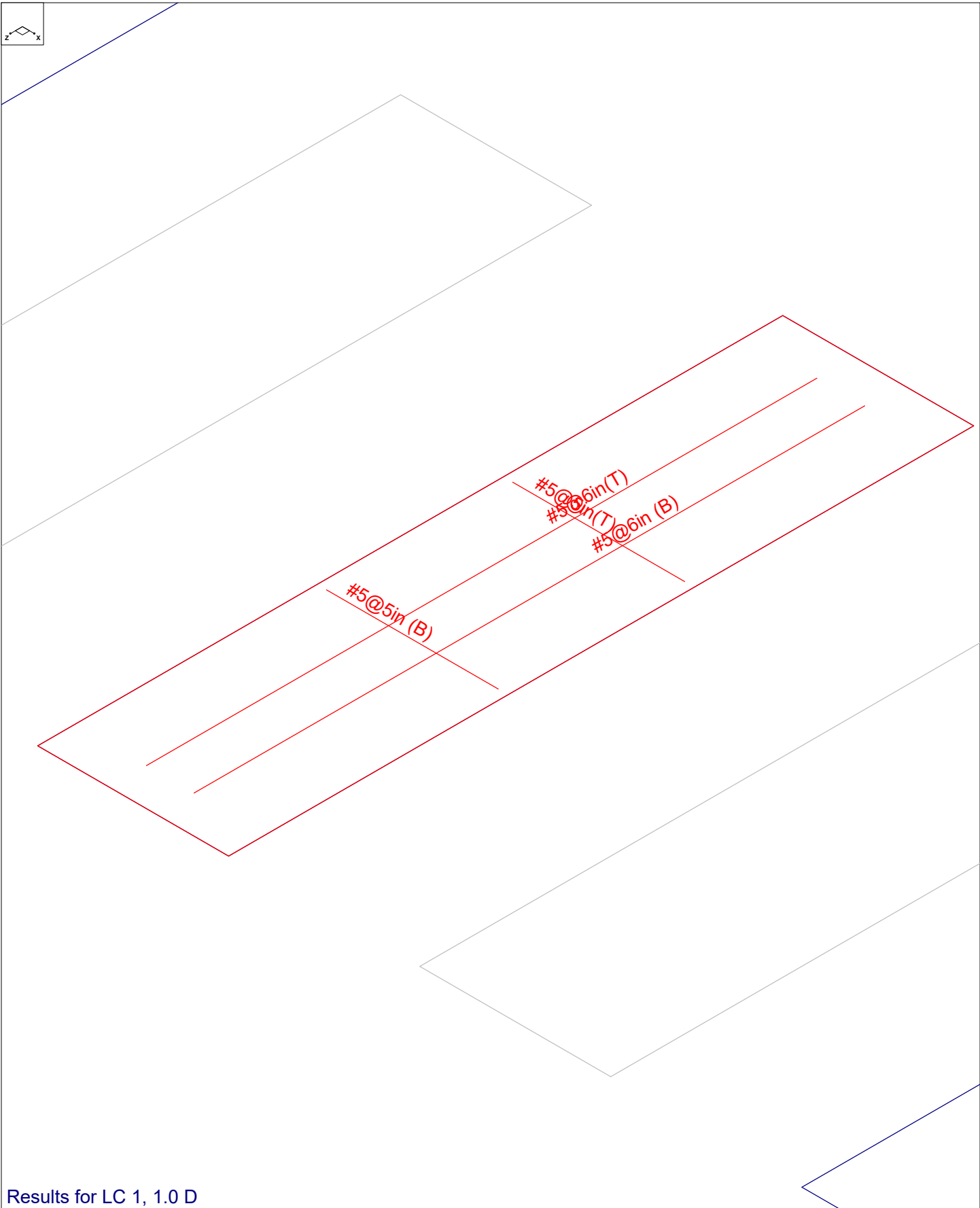

Results for LC 1, 1.0 D

Vector Structural Engineeri..	Ground Mount	SK - 1
STB		Mar 30, 2021 at 4:29 PM
U2716.115.191		Sunmodo Sunturf A9 v3 85x45.r3d



**(Global) Model Settings**

Display Sections for Member Calcs	5
Max Internal Sections for Member Calcs	100
Mesh Size (in)	12
Max Iterations	10
Merge Tolerance (in)	.12
Solver	Sparse Accelerated
Coefficient of Friction	.3
No. of Shear Regions	4
Shear Region Spacing Increment (in)	4
Min 1 Bar Dia Spacing for Beams?	No
Optimize footings for OTM / Sliding?	Yes
Parame Beta Factor	.65
Pile Safety Factor	3
Concrete Stress Block	0
Concrete Rebar Set	Rectangular
Concrete Code	ASTM A615
HR Steel Pile Code	ACI 318-14
Wood Pile Code	AISC 14th (360-10): ASD AWC NDS-15: ASD

**Concrete Properties**

	Label	E [ksi]	G [ksi]	Nu	Therm (/...	Density[lb/ft^3]	fc[psi]	Lambda	Flex Stee...	Shear St...
1	Conc3000NW	3156	1372	.15	.6	145	3000	1	60000	60000
2	Conc3500NW	3409	1482	.15	.6	145	3500	1	60000	60000
3	Conc4000NW	3644	1584	.15	.6	145	4000	1	60000	60000
4	Conc3000LW	2085	907	.15	.6	109.999	3000	.75	60000	60000
5	Conc3500LW	2252	979	.15	.6	109.999	3500	.75	60000	60000
6	Conc4000LW	2408	1047	.15	.6	109.999	4000	.75	60000	60000
7	Conc2500NW	3156	1372	.15	.6	145	2500	1	60000	60000

**General Design Parameters**

	Label	Max Bending Chk	Max Shear Chk	Top Cover[in]	Bottom Cover[in]
1	Typical	1	1	3	3

**Slab Rebar Parameters**

	Label	Top Bar	Bottom Bar	Max Top Bar Sp...	Min Top Bar Sp...	Max Bot Bar Sp...	Min Bot Bar Sp...	Spacing Incr...	Rebar Options
1	Typical	#5	#5	12	3	12	3	1	Optimize

**Soil Definitions**

	Label	Subgrade Modulus[lb/ft^3]	Allowable Bearing[psf]	Depth Properties	Default?
1	Default	1e+5	1500	None	Yes

**Point Loads and Moments (Cat 1 : DL)**

	Label	Direction	Magnitude[lb.-ft]
1	R3D_N1_1	X	-3.98
2	R3D_N1_1	Y	178.273
3	R3D_N2	Y	158.516
4	R3D_N132_1	Y	174.459
5	R3D_N133_1	Y	168.182
6	R3D_N109_1	Y	171.845
7	R3D_N110A_1	Y	169.721
8	R3D_N121_1	Y	175.462

**Point Loads and Moments (Cat 1 : DL) (Continued)**

	Label	Direction	Magnitude[lb,lb-ft]
9	R3D N122 1	Y	169.648
10	R3D N133B	Y	176.265
11	R3D N134B 1	Y	170.596
12	R3D N151 1	Y	174.762
13	R3D N152 1	Y	168.584
14	R3D N143A	Y	175.943
15	R3D N144A	Y	170.266
16	R3D N149A 1	Y	176.347
17	R3D N150A 1	Y	170.317
18	R3D N155B	X	3.82
19	R3D N155B	Y	188.842
20	R3D N156B	Y	169.101
21	R3D N161A	Y	167.594
22	R3D N162A	Y	166.106

**Point Loads and Moments (Cat 6 : RLL)**

	Label	Direction	Magnitude[lb,lb-ft]
1	R3D N1 1	X	-21.702
2	R3D N1 1	Y	785.405
3	R3D N2	X	-6.227
4	R3D N2	Y	793.566
5	R3D N132 1	X	-1.022
6	R3D N132 1	Y	804.458
7	R3D N133 1	X	-3.243
8	R3D N133 1	Y	851.582
9	R3D N109 1	Y	775.38
10	R3D N109 1	Z	-2.175
11	R3D N110A 1	Y	863.372
12	R3D N121 1	Y	812.243
13	R3D N121 1	Z	1.889
14	R3D N122 1	X	2.144
15	R3D N122 1	Y	860.793
16	R3D N133B	Y	815.3
17	R3D N134B 1	X	-1.204
18	R3D N134B 1	Y	866.267
19	R3D N151 1	X	1.092
20	R3D N151 1	Y	806.457
21	R3D N152 1	X	3.992
22	R3D N152 1	Y	854.235
23	R3D N143A	Y	813.328
24	R3D N144A	X	2.085
25	R3D N144A	Y	864.255
26	R3D N149A 1	Y	817.326
27	R3D N149A 1	Z	1.86
28	R3D N150A 1	X	-1.808
29	R3D N150A 1	Y	864.514
30	R3D N155B	X	20.773
31	R3D N155B	Y	846.639
32	R3D N156B	X	1.002
33	R3D N156B	Y	855.305
34	R3D N161A	X	1.057
35	R3D N161A	Y	750.771
36	R3D N161A	Z	-2.077
37	R3D N162A	X	2.549
38	R3D N162A	Y	842.455

**Point Loads and Moments (Cat 16 : OL1)**

	Label	Direction	Magnitude[lb.-ft]
1	R3D N1 1	X	64.071
2	R3D N1 1	Y	-4003.466
3	R3D N1 1	Z	2315.465
4	R3D N2	X	8.986
5	R3D N2	Y	716.924
6	R3D N2	Z	-104.451
7	R3D N132 1	X	3.164
8	R3D N132 1	Y	-4168.337
9	R3D N132 1	Z	2484.512
10	R3D N133 1	X	1.423
11	R3D N133 1	Y	767.395
12	R3D N133 1	Z	-109.757
13	R3D N109 1	X	1.029
14	R3D N109 1	Y	-4073.985
15	R3D N109 1	Z	2507.751
16	R3D N110A 1	X	-1.739
17	R3D N110A 1	Y	765.689
18	R3D N110A 1	Z	-108.484
19	R3D N121 1	X	-1.185
20	R3D N121 1	Y	-4269.494
21	R3D N121 1	Z	2535.009
22	R3D N122 1	X	-6.527
23	R3D N122 1	Y	829.706
24	R3D N122 1	Z	-110.317
25	R3D N133B	X	1.692
26	R3D N133B	Y	-4229.023
27	R3D N133B	Z	2515.941
28	R3D N134B 1	X	-1.576
29	R3D N134B 1	Y	781.946
30	R3D N134B 1	Z	-110.291
31	R3D N151 1	X	-3.253
32	R3D N151 1	Y	-4216.587
33	R3D N151 1	Z	2516.685
34	R3D N152 1	X	-4.449
35	R3D N152 1	Y	805.707
36	R3D N152 1	Z	-110.212
37	R3D N143A	X	-1.992
38	R3D N143A	Y	-4197.39
39	R3D N143A	Z	2495.456
40	R3D N144A	Y	758.257
41	R3D N144A	Z	-110.114
42	R3D N149A 1	X	1.155
43	R3D N149A 1	Y	-4295.71
44	R3D N149A 1	Z	2551.214
45	R3D N150A 1	X	5.521
46	R3D N150A 1	Y	837.19
47	R3D N150A 1	Z	-110.608
48	R3D N155B	X	-61.38
49	R3D N155B	Y	-4315.828
50	R3D N155B	Z	2500.451
51	R3D N156B	X	2.651
52	R3D N156B	Y	779.386
53	R3D N156B	Z	-109.432
54	R3D N161A	X	-3.305
55	R3D N161A	Y	-3957.978
56	R3D N161A	Z	2438.721
57	R3D N162A	X	-3.304



**Point Loads and Moments (Cat 17 : OL2) (Continued)**

	Label	Direction	Magnitude[lb.-lb-ft]
52	R3D_N156B	Z	-92.221
53	R3D_N161A	X	-4.188
54	R3D_N161A	Y	-4372.776
55	R3D_N161A	Z	2038.377
56	R3D_N162A	Y	1729.376
57	R3D_N162A	Z	-91.307

**Point Loads and Moments (Cat 18 : OL3)**

	Label	Direction	Magnitude[lb.-lb-ft]
1	R3D_N1_1	X	-74.711
2	R3D_N1_1	Y	4668.301
3	R3D_N1_1	Z	-2699.982
4	R3D_N2	X	-10.478
5	R3D_N2	Y	-835.98
6	R3D_N2	Z	121.797
7	R3D_N132_1	X	-3.689
8	R3D_N132_1	Y	4860.552
9	R3D_N132_1	Z	-2897.103
10	R3D_N133_1	X	-1.66
11	R3D_N133_1	Y	-894.833
12	R3D_N133_1	Z	127.984
13	R3D_N109_1	X	-1.2
14	R3D_N109_1	Y	4750.531
15	R3D_N109_1	Z	-2924.2
16	R3D_N110A_1	X	2.028
17	R3D_N110A_1	Y	-892.843
18	R3D_N110A_1	Z	126.5
19	R3D_N121_1	X	1.382
20	R3D_N121_1	Y	4978.507
21	R3D_N121_1	Z	-2955.985
22	R3D_N122_1	X	7.61
23	R3D_N122_1	Y	-967.491
24	R3D_N122_1	Z	128.637
25	R3D_N133B	X	-1.973
26	R3D_N133B	Y	4931.316
27	R3D_N133B	Z	-2933.751
28	R3D_N134B_1	X	1.838
29	R3D_N134B_1	Y	-911.8
30	R3D_N134B_1	Z	128.607
31	R3D_N151_1	X	3.793
32	R3D_N151_1	Y	4916.814
33	R3D_N151_1	Z	-2934.618
34	R3D_N152_1	X	5.188
35	R3D_N152_1	Y	-939.507
36	R3D_N152_1	Z	128.514
37	R3D_N143A	X	2.322
38	R3D_N143A	Y	4894.429
39	R3D_N143A	Z	-2909.864
40	R3D_N144A	X	1.153
41	R3D_N144A	Y	-884.176
42	R3D_N144A	Z	128.4
43	R3D_N149A_1	X	-1.347
44	R3D_N149A_1	Y	5009.077
45	R3D_N149A_1	Z	-2974.881
46	R3D_N150A_1	X	-6.437
47	R3D_N150A_1	Y	-976.218









Company : Vector Structural Engineering  
 Designer : STB  
 Job Number : U2716.115.191  
 Model Name : Ground Mount

Mar 30, 2021  
 4:30 PM  
 Checked By: JSP

**Slab Overturning Safety Factors (By Combination) (Continued)**

LC	Slab	Angle[deg]	Mo-xx[lb-ft]	Ms-xx[lb-ft]	Mo-zz[lb-ft]	Ms-zz[lb-ft]	Ms-xx/Mo-xx	Ms-zz/Mo-zz	
30	3	S10	0	24326.412	44858.768	2740.425	11501.921	1.844	4.197
31	4	S1	0	23641.811	44757.456	2242.828	11475.878	1.893	5.117
32	4	S2	0	23856.842	44719.361	2043.834	11471.897	1.874	5.613
33	4	S3	0	25149.074	44749.112	2187.374	11476.329	1.779	5.247
34	4	S4	0	24890.079	44756.996	2176.829	11478.516	1.798	5.273
35	4	S5	0	24498.726	44738.878	2150.334	11473.242	1.826	5.336
36	4	S6	0	24810.404	44741.917	2160.729	11474.124	1.803	5.31
37	4	S7	0	24686.946	44753.897	2168.787	11477.701	1.813	5.292
38	4	S8	0	25308.53	44757.301	2199.267	11478.271	1.768	5.219
39	4	S9	0	23182.38	44679.471	1988.832	11462.065	1.927	5.763
40	4	S10	0	25468.172	44858.768	2388.997	11501.921	1.761	4.815
41	5	S1	0	3887.513	44676.928	0	14477.902	9.999+	9.999+
42	5	S2	0	4429.938	44761.589	0	14363.922	9.999+	9.999+
43	5	S3	0	4646.207	44766.406	0	14471.102	9.635	9.999+
44	5	S4	0	4374.133	44775.584	0	14493.355	9.999+	9.999+
45	5	S5	0	4298.097	44752.562	0	14455.555	9.999+	9.999+
46	5	S6	0	4528.544	44756.402	0	14443.631	9.883	9.999+
47	5	S7	0	4232.31	44772.324	0	14480.178	9.999+	9.999+
48	5	S8	0	4690.598	44773.366	0	14514.592	9.545	9.999+
49	5	S9	0	4281.931	44724.787	0	14264.389	9.999+	9.999+
50	5	S10	0	4242.368	44781.872	0	14472.888	9.999+	9.999+
51	6	S1	0	0	45029.378	0	14104.041	9.999+	9.999+
52	6	S2	0	0	45000.801	0	14107.417	9.999+	9.999+
53	6	S3	0	0	44876.041	0	14160.454	9.999+	9.999+
54	6	S4	0	0	45105.083	0	14189.802	9.999+	9.999+
55	6	S5	0	0	45014.112	0	14154.001	9.999+	9.999+
56	6	S6	0	0	44895.434	0	14132.853	9.999+	9.999+
57	6	S7	0	0	45175.593	0	14173.314	9.999+	9.999+
58	6	S8	0	0	44866.44	0	14197.573	9.999+	9.999+
59	6	S9	0	0	45004.42	0	14021.065	9.999+	9.999+
60	6	S10	0	0	45110.391	0	14161.337	9.999+	9.999+
61	7	S1	0	16920.134	50410.74	1930.869	13008.531	2.979	6.737
62	7	S2	0	17364.461	50384.5	1861.715	13008.227	2.902	6.987
63	7	S3	0	18080.484	50632.14	1943.557	13048.82	2.8	6.714
64	7	S4	0	17937.469	50667.96	1938.851	13052.729	2.825	6.732
65	7	S5	0	17686.146	50568.069	1918.191	13033.777	2.859	6.795
66	7	S6	0	17877.967	50586.131	1927.285	13040.553	2.83	6.766
67	7	S7	0	17811.398	50650.648	1936.753	13054.346	2.844	6.74
68	7	S8	0	18191.223	50675.559	1952.928	13058.385	2.786	6.687
69	7	S9	0	16871.013	50171.243	1817.294	12962.475	2.974	7.133
70	7	S10	0	18244.809	50952.678	2055.319	13138.321	2.793	6.392
71	8	S1	0	17731.358	50410.74	1682.121	13008.531	2.843	7.733
72	8	S2	0	17892.631	50384.5	1532.876	13008.227	2.816	8.486
73	8	S3	0	18861.806	50632.14	1640.531	13048.82	2.684	7.954
74	8	S4	0	18667.559	50667.96	1632.621	13052.729	2.714	7.995
75	8	S5	0	18374.045	50568.069	1612.742	13017.782	2.752	8.072
76	8	S6	0	18607.803	50586.131	1620.547	13040.553	2.719	8.047
77	8	S7	0	18515.209	50650.648	1626.406	13046.525	2.736	8.022
78	8	S8	0	18981.398	50675.559	1649.45	13058.385	2.67	7.917
79	8	S9	0	17386.785	50171.243	1491.624	12962.475	2.886	8.69
80	8	S10	0	19101.129	50952.678	1791.748	13138.321	2.668	7.333
81	9	S1	0	2915.635	50569.889	0	15260.05	9.999+	9.999+
82	9	S2	0	3322.453	51079.845	0	15177.246	9.999+	9.999+
83	9	S3	0	3484.656	51117.471	0	15286.858	9.999+	9.999+
84	9	S4	0	3280.6	51161.103	0	15318.372	9.999+	9.999+
85	9	S5	0	3223.573	51033.183	0	15270.512	9.999+	9.999+
86	9	S6	0	3396.408	51056.018	0	15248.622	9.999+	9.999+



Company : Vector Structural Engineering  
 Designer : STB  
 Job Number : U2716.115.191  
 Model Name : Ground Mount

Mar 30, 2021  
 4:30 PM  
 Checked By: JSP

**Slab Overturning Safety Factors (By Combination) (Continued)**

LC	Slab	Angle[deg]	Mo-xx[lb-ft]	Ms-xx[lb-ft]	Mo-zz[lb-ft]	Ms-zz[lb-ft]	Ms-xx/Mo-xx	Ms-zz/Mo-zz	
87	9	S7	0	3174.233	51142.924	0	15298.383	9.999+	9.999+
88	9	S8	0	3517.949	51153.582	0	15335.626	9.999+	9.999+
89	9	S9	0	3211.448	50883.505	0	15050.697	9.999+	9.999+
90	9	S10	0	3181.776	51133.447	0	15280.114	9.999+	9.999+
91	10	S1	0	0	50834.226	0	14979.653	9.999+	9.999+
92	10	S2	0	0	51259.254	0	14984.867	9.999+	9.999+
93	10	S3	0	0	51199.697	0	15053.872	9.999+	9.999+
94	10	S4	0	0	51408.228	0	15090.707	9.999+	9.999+
95	10	S5	0	0	51229.345	0	15044.346	9.999+	9.999+
96	10	S6	0	0	51160.292	0	15015.538	9.999+	9.999+
97	10	S7	0	0	51445.376	0	15068.235	9.999+	9.999+
98	10	S8	0	0	51223.388	0	15097.861	9.999+	9.999+
99	10	S9	0	0	51093.23	0	14868.205	9.999+	9.999+
100	10	S10	0	0	51379.836	0	15046.451	9.999+	9.999+
101	11	S1	0	22560.178	40281.71	2574.492	10328.29	1.786	4.012
102	11	S2	0	23152.615	40247.425	2482.287	10324.707	1.738	4.159
103	11	S3	0	24107.311	40274.201	2591.409	10328.696	1.671	3.986
104	11	S4	0	23916.625	40281.296	2585.481	10330.665	1.684	3.996
105	11	S5	0	23581.528	40264.991	2557.588	10325.918	1.707	4.037
106	11	S6	0	23837.29	40267.726	2569.713	10326.712	1.689	4.019
107	11	S7	0	23748.531	40278.508	2582.337	10329.931	1.696	4
108	11	S8	0	24254.964	40281.571	2603.904	10330.444	1.661	3.967
109	11	S9	0	22494.684	40211.524	2423.059	10315.858	1.788	4.257
110	11	S10	0	24326.412	40372.891	2740.425	10351.729	1.66	3.777
111	12	S1	0	23641.811	40281.71	2242.828	10328.29	1.704	4.605
112	12	S2	0	23856.842	40247.425	2043.834	10324.707	1.687	5.052
113	12	S3	0	25149.074	40274.201	2187.374	10328.696	1.601	4.722
114	12	S4	0	24890.079	40281.296	2176.829	10330.665	1.618	4.746
115	12	S5	0	24498.726	40264.991	2150.334	10325.918	1.644	4.802
116	12	S6	0	24810.404	40267.726	2160.729	10326.712	1.623	4.779
117	12	S7	0	24686.946	40278.508	2168.787	10329.931	1.632	4.763
118	12	S8	0	25308.53	40281.571	2199.267	10330.444	1.592	4.697
119	12	S9	0	23182.38	40211.524	1988.832	10315.858	1.735	5.187
120	12	S10	0	25468.172	40372.891	2388.997	10351.729	1.585	4.333
121	13	S1	0	3887.513	40209.235	0	13330.314	9.999+	9.999+
122	13	S2	0	4429.938	40285.43	0	13216.732	9.094	9.999+
123	13	S3	0	4646.207	40289.765	0	13323.469	8.672	9.999+
124	13	S4	0	4374.133	40298.026	0	13345.503	9.213	9.999+
125	13	S5	0	4298.097	40277.306	0	13308.231	9.371	9.999+
126	13	S6	0	4528.544	40280.762	0	13296.219	8.895	9.999+
127	13	S7	0	4232.31	40295.091	0	13332.408	9.521	9.999+
128	13	S8	0	4690.598	40296.029	0	13366.765	8.591	9.999+
129	13	S9	0	4281.931	40252.308	0	13118.182	9.401	9.999+
130	13	S10	0	4242.368	40303.685	0	13324.606	9.5	9.999+
131	14	S1	0	0	40561.685	0	12956.453	9.999+	9.999+
132	14	S2	0	0	40524.642	0	12960.227	9.999+	9.999+
133	14	S3	0	0	40399.4	0	13012.821	9.999+	9.999+
134	14	S4	0	0	40627.525	0	13041.951	9.999+	9.999+
135	14	S5	0	0	40538.856	0	13006.677	9.999+	9.999+
136	14	S6	0	0	40419.794	0	12985.44	9.999+	9.999+
137	14	S7	0	0	40698.36	0	13025.544	9.999+	9.999+
138	14	S8	0	0	40389.103	0	13049.745	9.999+	9.999+
139	14	S9	0	0	40531.941	0	12874.859	9.999+	9.999+
140	14	S10	0	0	40632.204	0	13013.055	9.999+	9.999+



Company : Vector Structural Engineering  
 Designer : STB  
 Job Number : U2716.115.191  
 Model Name : Ground Mount

Mar 30, 2021  
 4:30 PM  
 Checked By: JSP

**Slab Sliding Safety Factors (By Combination)**

	LC	Slab	Angle[deg]	Va-xx[lb]	Vr-xx[lb]	Va-zz[lb]	Vr-zz[lb]	SR-xx	SR-zz
1	1	S1	0	3.98	2751.822	0	2751.822	9.999+	9.999+
2	1	S2	0	0	2753.255	0	2753.255	9.999+	9.999+
3	1	S3	0	0	2754.319	0	2754.319	9.999+	9.999+
4	1	S4	0	0	2754.844	0	2754.844	9.999+	9.999+
5	1	S5	0	0	2753.578	0	2753.578	9.999+	9.999+
6	1	S6	0	0	2753.79	0	2753.79	9.999+	9.999+
7	1	S7	0	0	2754.648	0	2754.648	9.999+	9.999+
8	1	S8	0	0	2754.785	0	2754.785	9.999+	9.999+
9	1	S9	0	0	2750.896	0	2750.896	9.999+	9.999+
10	1	S10	0	3.82	2758.169	0	2758.169	9.999+	9.999+
11	2	S1	0	31.91	3225.514	0	3225.514	9.999+	9.999+
12	2	S2	0	0	3244.881	2.175	3244.881	9.999+	9.999+
13	2	S3	0	2.144	3256.23	1.889	3256.23	9.999+	9.999+
14	2	S4	0	1.204	3259.314	0	3259.314	9.999+	9.999+
15	2	S5	0	4.265	3250.39	0	3250.39	9.999+	9.999+
16	2	S6	0	5.083	3251.997	0	3251.997	9.999+	9.999+
17	2	S7	0	2.085	3257.923	0	3257.923	9.999+	9.999+
18	2	S8	0	1.808	3259.337	1.86	3259.337	9.999+	9.999+
19	2	S9	0	3.606	3228.864	2.077	3228.864	9.999+	9.999+
20	2	S10	0	25.595	3268.752	0	3268.752	9.999+	9.999+
21	3	S1	0	39.854	2160.245	1326.608	2160.245	9.999+	1.628
22	3	S2	0	.426	2157.762	1439.56	2157.762	9.999+	1.499
23	3	S3	0	4.627	2135.157	1454.815	2135.157	9.999+	1.468
24	3	S4	0	.069	2134.37	1443.39	2134.37	9.999+	1.479
25	3	S5	0	2.752	2141.409	1424.853	2141.409	9.999+	1.503
26	3	S6	0	4.622	2139.831	1443.884	2139.831	9.999+	1.482
27	3	S7	0	1.195	2135.604	1431.205	2135.604	9.999+	1.492
28	3	S8	0	4.006	2132.251	1464.363	2132.251	9.999+	1.456
29	3	S9	0	3.966	2171.741	1398.005	2171.741	9.999+	1.553
30	3	S10	0	31.417	2121.609	1434.611	2121.609	9.999+	1.479
31	4	S1	0	45.781	2243.401	1121.412	2243.401	9.999+	2.001
32	4	S2	0	.726	2263.171	1201.545	2263.171	9.999+	1.884
33	4	S3	0	3.6	2231.509	1233.322	2231.509	9.999+	1.809
34	4	S4	0	1.182	2233.114	1215.809	2233.114	9.999+	1.837
35	4	S5	0	.002	2237.499	1196.045	2237.499	9.999+	1.871
36	4	S6	0	1.566	2236.154	1218.746	2236.154	9.999+	1.835
37	4	S7	0	.049	2234.169	1201.69	2234.169	9.999+	1.859
38	4	S8	0	3.164	2228.859	1241.653	2228.859	9.999+	1.795
39	4	S9	0	2.513	2275.083	1168.242	2275.083	9.999+	1.947
40	4	S10	0	40.842	2211.607	1211.433	2211.607	9.999+	1.826
41	5	S1	0	55.094	3441.64	1546.911	3441.64	9.999+	2.225
42	5	S2	0	.497	3447.639	1678.62	3447.639	9.999+	2.054
43	5	S3	0	5.396	3476.302	1696.409	3476.302	9.999+	2.049
44	5	S4	0	.081	3478.357	1683.086	3478.357	9.999+	2.067
45	5	S5	0	3.21	3467.408	1661.471	3467.408	9.999+	2.087
46	5	S6	0	5.389	3469.705	1683.662	3469.705	9.999+	2.061
47	5	S7	0	2.085	3476.494	1668.878	3476.494	9.999+	2.083
48	5	S8	0	4.671	3480.7	1707.543	3480.7	9.999+	2.038
49	5	S9	0	4.624	3426.228	1630.165	3426.228	9.999+	2.102
50	5	S10	0	44.909	3500.439	1672.85	3500.439	9.999+	2.093
51	6	S1	0	38.208	3362.045	1385.108	3362.045	9.999+	2.427
52	6	S2	0	1.808	3386.865	1516.723	3386.865	9.999+	2.233
53	6	S3	0	4.656	3401.303	1515.818	3401.303	9.999+	2.244
54	6	S4	0	.672	3405.15	1510.892	3405.15	9.999+	2.254
55	6	S5	0	4.946	3393.993	1495.188	3393.993	9.999+	2.27
56	6	S6	0	6.912	3396.032	1509.161	3396.032	9.999+	2.25
57	6	S7	0	3.171	3403.498	1501.575	3403.498	9.999+	2.267



**Slab Sliding Safety Factors (By Combination) (Continued)**

	LC	Slab	Angle[deg]	Va-xx[lb]	Vr-xx[lb]	Va-zz[lb]	Vr-zz[lb]	SR-xx	SR-zz
58	6	S8	0	3.942	3405.052	1525.556	3405.052	9.999+	2.232
59	6	S9	0	4.669	3367.857	1471.71	3367.857	9.999+	2.288
60	6	S10	0	27.555	3415.254	1499.011	3415.254	9.999+	2.278
61	7	S1	0	7.948	2663.408	994.956	2663.408	9.999+	2.677
62	7	S2	0	.319	2675.355	1078.039	2675.355	9.999+	2.482
63	7	S3	0	1.862	2666.381	1092.529	2666.381	9.999+	2.441
64	7	S4	0	.851	2667.841	1082.542	2667.841	9.999+	2.464
65	7	S5	0	1.135	2667.06	1068.64	2667.06	9.999+	2.496
66	7	S6	0	.346	2666.977	1082.913	2666.977	9.999+	2.463
67	7	S7	0	.668	2667.822	1073.404	2667.822	9.999+	2.485
68	7	S8	0	1.648	2666.299	1099.668	2666.299	9.999+	2.425
69	7	S9	0	.27	2675.005	1046.946	2675.005	9.999+	2.555
70	7	S10	0	6.277	2663.687	1075.958	2663.687	9.999+	2.476
71	8	S1	0	12.393	2725.774	841.059	2725.774	9.999+	3.241
72	8	S2	0	.545	2754.411	899.527	2754.411	9.999+	3.062
73	8	S3	0	1.091	2738.644	926.409	2738.644	9.999+	2.956
74	8	S4	0	1.789	2741.9	911.857	2741.9	9.999+	3.007
75	8	S5	0	3.197	2739.128	897.033	2739.128	9.999+	3.054
76	8	S6	0	2.638	2739.219	914.059	2739.219	9.999+	2.997
77	8	S7	0	1.527	2741.745	901.267	2741.745	9.999+	3.042
78	8	S8	0	1.017	2738.755	932.635	2738.755	9.999+	2.937
79	8	S9	0	.82	2752.513	874.624	2752.513	9.999+	3.147
80	8	S10	0	13.345	2731.185	908.575	2731.185	9.999+	3.006
81	9	S1	0	63.263	3624.454	1160.183	3624.454	9.999+	3.124
82	9	S2	0	.373	3642.762	1260.596	3642.762	9.999+	2.89
83	9	S3	0	5.655	3672.239	1270.89	3672.239	9.999+	2.89
84	9	S4	0	.963	3675.831	1262.315	3675.831	9.999+	2.912
85	9	S5	0	5.606	3661.559	1246.103	3661.559	9.999+	2.938
86	9	S6	0	7.854	3664.382	1262.747	3664.382	9.999+	2.902
87	9	S7	0	3.128	3673.489	1251.659	3673.489	9.999+	2.935
88	9	S8	0	4.859	3677.635	1279.262	3677.635	9.999+	2.875
89	9	S9	0	6.172	3615.871	1224.181	3615.871	9.999+	2.954
90	9	S10	0	50.968	3697.808	1254.637	3697.808	9.999+	2.947
91	10	S1	0	50.598	3564.758	1038.831	3564.758	9.999+	3.432
92	10	S2	0	1.356	3597.182	1139.174	3597.182	9.999+	3.158
93	10	S3	0	5.101	3615.99	1135.447	3615.99	9.999+	3.185
94	10	S4	0	1.406	3620.926	1133.169	3620.926	9.999+	3.195
95	10	S5	0	6.909	3606.498	1121.391	3606.498	9.999+	3.216
96	10	S6	0	8.997	3609.127	1131.871	3609.127	9.999+	3.189
97	10	S7	0	3.942	3618.742	1126.181	3618.742	9.999+	3.213
98	10	S8	0	4.312	3620.9	1142.772	3620.9	9.999+	3.169
99	10	S9	0	6.206	3572.093	1105.34	3572.093	9.999+	3.232
100	10	S10	0	37.952	3633.92	1124.258	3633.92	9.999+	3.232
101	11	S1	0	40.252	1885.063	1326.608	1885.063	9.999+	1.421
102	11	S2	0	.426	1882.436	1439.56	1882.436	9.999+	1.308
103	11	S3	0	4.627	1859.725	1454.815	1859.725	9.999+	1.278
104	11	S4	0	.069	1858.886	1443.39	1858.886	9.999+	1.288
105	11	S5	0	2.752	1866.051	1424.853	1866.051	9.999+	1.31
106	11	S6	0	4.622	1864.452	1443.884	1864.452	9.999+	1.291
107	11	S7	0	1.195	1860.139	1431.205	1860.139	9.999+	1.3
108	11	S8	0	4.006	1856.773	1464.363	1856.773	9.999+	1.268
109	11	S9	0	3.966	1896.651	1398.005	1896.651	9.999+	1.357
110	11	S10	0	31.799	1845.792	1434.611	1845.792	9.999+	1.287
111	12	S1	0	46.179	1968.218	1121.412	1968.218	9.999+	1.755
112	12	S2	0	.726	1987.845	1201.545	1987.845	9.999+	1.654
113	12	S3	0	3.6	1956.077	1233.322	1956.077	9.999+	1.586
114	12	S4	0	1.182	1957.63	1215.809	1957.63	9.999+	1.61

**Slab Sliding Safety Factors (By Combination) (Continued)**

	LC	Slab	Angle[deg]	Va-xx[lb]	Vr-xx[lb]	Va-zz[lb]	Vr-zz[lb]	SR-xx	SR-zz
115	12	S5	0	.002	1962.141	1196.045	1962.141	9.999+	1.641
116	12	S6	0	1.566	1960.775	1218.746	1960.775	9.999+	1.609
117	12	S7	0	.049	1958.704	1201.69	1958.704	9.999+	1.63
118	12	S8	0	3.164	1953.381	1241.653	1953.381	9.999+	1.573
119	12	S9	0	2.513	1999.994	1168.242	1999.994	9.999+	1.712
120	12	S10	0	41.224	1935.79	1211.433	1935.79	9.999+	1.598
121	13	S1	0	54.696	3166.458	1546.911	3166.458	9.999+	2.047
122	13	S2	0	.497	3172.314	1678.62	3172.314	9.999+	1.89
123	13	S3	0	5.396	3200.87	1696.409	3200.87	9.999+	1.887
124	13	S4	0	.081	3202.872	1683.086	3202.872	9.999+	1.903
125	13	S5	0	3.21	3192.05	1661.471	3192.05	9.999+	1.921
126	13	S6	0	5.389	3194.326	1683.662	3194.326	9.999+	1.897
127	13	S7	0	2.085	3201.029	1668.878	3201.029	9.999+	1.918
128	13	S8	0	4.671	3205.221	1707.543	3205.221	9.999+	1.877
129	13	S9	0	4.624	3151.138	1630.165	3151.138	9.999+	1.933
130	13	S10	0	44.527	3224.622	1672.85	3224.622	9.999+	1.928
131	14	S1	0	37.81	3086.863	1385.108	3086.863	9.999+	2.229
132	14	S2	0	1.808	3111.539	1516.723	3111.539	9.999+	2.051
133	14	S3	0	4.656	3125.871	1515.818	3125.871	9.999+	2.062
134	14	S4	0	.672	3129.665	1510.892	3129.665	9.999+	2.071
135	14	S5	0	4.946	3118.635	1495.188	3118.635	9.999+	2.086
136	14	S6	0	6.912	3120.653	1509.161	3120.653	9.999+	2.068
137	14	S7	0	3.171	3128.033	1501.575	3128.033	9.999+	2.083
138	14	S8	0	3.942	3129.574	1525.556	3129.574	9.999+	2.051
139	14	S9	0	4.669	3092.768	1471.71	3092.768	9.999+	2.101
140	14	S10	0	27.173	3139.437	1499.011	3139.437	9.999+	2.094

**Envelope Slab Soil Pressures**

	Label	UC	LC	Soil Pressure[psf]	Allowable Bearing[psf]	Point
1	S1	.5	5	749.942	1500	N282
2	S2	.504	5	756.357	1500	N289
3	S3	.517	5	775.948	1500	N296
4	S4	.514	5	770.922	1500	N303
5	S5	.51	5	765.041	1500	N310
6	S6	.514	5	770.514	1500	N317
7	S7	.512	5	767.368	1500	N324
8	S8	.519	5	778.557	1500	N331
9	S9	.497	5	745.054	1500	N338
10	S10	.52	5	780.05	1500	N345



Company:		Date:	5/14/2018
Engineer:		Page:	1/6
Project:			
Address:			
Phone:			
E-mail:			

**1. Project information**

Customer company:  
Customer contact name:  
Customer e-mail:  
Comment:

Project description:  
Location:  
Fastening description:

**2. Input Data & Anchor Parameters**

**General**

Design method: ACI 318-14  
Units: Imperial units

**Anchor Information:**

Anchor type: Bonded anchor  
Material: F1554 Grade 36  
Diameter (inch): 0.375  
Effective Embedment depth,  $h_{ef}$  (inch): 4.000  
Code report: ICC-ES ESR-4057  
Anchor category: -  
Anchor ductility: Yes  
 $h_{min}$  (inch): 5.25  
 $c_{ac}$  (inch): 7.12  
 $c_{min}$  (inch): 1.75  
 $s_{min}$  (inch): 3.00

**Base Material**

Concrete: Normal-weight  
Concrete thickness,  $h$  (inch): 30.00  
State: Cracked  
Compressive strength,  $f'_c$  (psi): 2500  
 $\Psi_{c,v}$ : 1.0  
Reinforcement condition: B tension, B shear  
Supplemental reinforcement: Not applicable  
Reinforcement provided at corners: No  
Ignore concrete breakout in tension: No  
Ignore concrete breakout in shear: No  
Hole condition: Dry concrete  
Inspection: Periodic  
Temperature range, Short/Long: 150/110°F  
Ignore 6do requirement: Not applicable  
Build-up grout pad: No

**Base Plate**

Length x Width x Thickness (inch): 4.75 x 4.75 x 0.31

**Recommended Anchor**

Anchor Name: SET-3G - SET-3G w/ 3/8"Ø F1554 Gr. 36  
Code Report: ICC-ES ESR-4057





Company:		Date:	5/14/2018
Engineer:		Page:	2/6
Project:			
Address:			
Phone:			
E-mail:			

**Load and Geometry**

Load factor source: ACI 318 Section 5.3

Load combination: not set

Seismic design: No

Anchors subjected to sustained tension: No

Apply entire shear load at front row: No

Anchors only resisting wind and/or seismic loads: No

Strength level loads:

$N_{ua}$  [lb]: 4680

$V_{uax}$  [lb]: 160

$V_{uay}$  [lb]: -2970

$M_{ux}$  [ft-lb]: 0

$M_{uy}$  [ft-lb]: 0

$M_{uz}$  [ft-lb]: 0

<Figure 1>

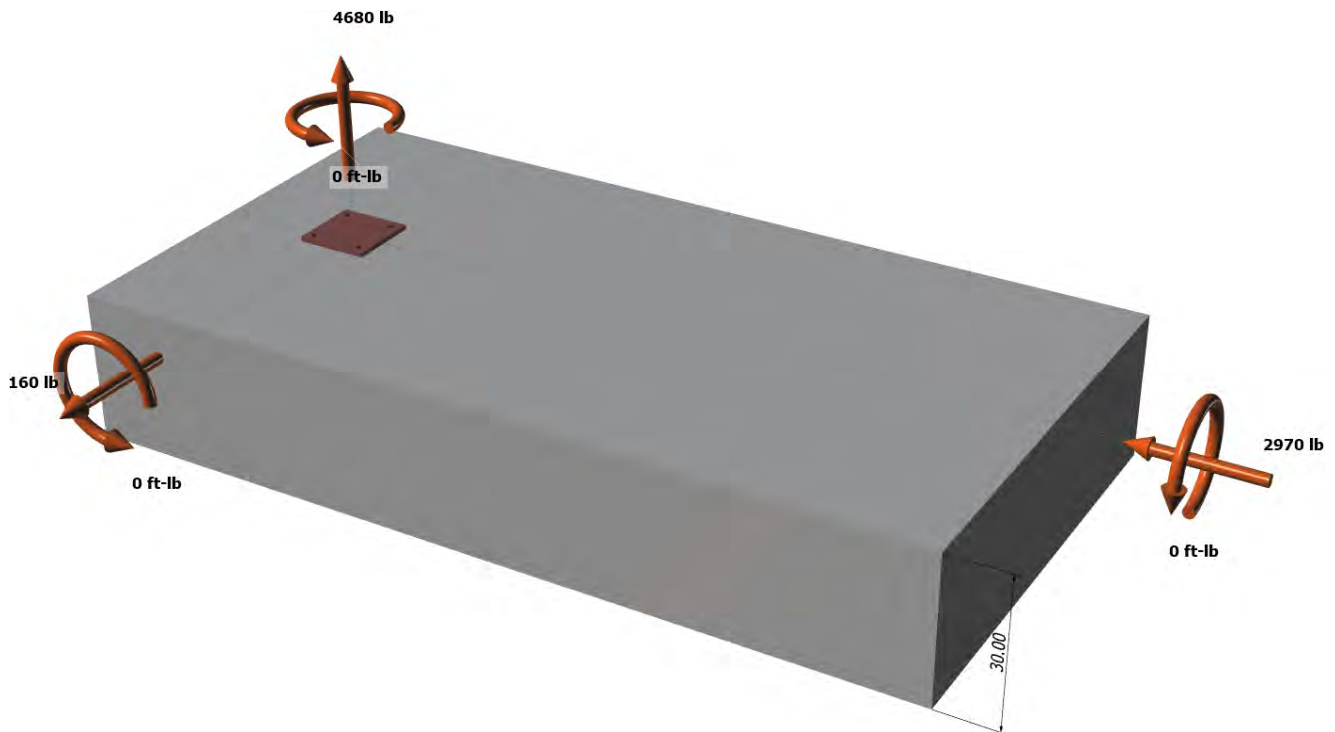



Company:		Date:	5/14/2018
Engineer:		Page:	3/6
Project:			
Address:			
Phone:			
E-mail:			

<Figure 2>





Company:		Date:	5/14/2018
Engineer:		Page:	4/6
Project:			
Address:			
Phone:			
E-mail:			

### 3. Resulting Anchor Forces

Anchor	Tension load, N <sub>ua</sub> (lb)	Shear load x, V <sub>uax</sub> (lb)	Shear load y, V <sub>uay</sub> (lb)	Shear load combined, $\sqrt{(V_{uax})^2 + (V_{uay})^2}$ (lb)
1	1170.0	40.0	-742.5	743.6
2	1170.0	40.0	-742.5	743.6
3	1170.0	40.0	-742.5	743.6
4	1170.0	40.0	-742.5	743.6
Sum	4680.0	160.0	-2970.0	2974.3

Maximum concrete compression strain (%): 0.00  
 Maximum concrete compression stress (psi): 0  
 Resultant tension force (lb): 4680  
 Resultant compression force (lb): 0  
 Eccentricity of resultant tension forces in x-axis, e'<sub>Nx</sub> (inch): 0.00  
 Eccentricity of resultant tension forces in y-axis, e'<sub>Ny</sub> (inch): 0.00  
 Eccentricity of resultant shear forces in x-axis, e'<sub>Vx</sub> (inch): 0.00  
 Eccentricity of resultant shear forces in y-axis, e'<sub>Vy</sub> (inch): 0.00

<Figure 3>

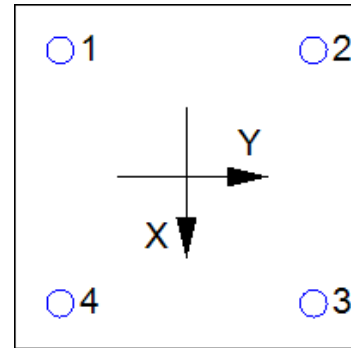

### 4. Steel Strength of Anchor in Tension (Sec. 17.4.1)

N <sub>sa</sub> (lb)	φ	φN <sub>sa</sub> (lb)
4525	0.75	3394

### 5. Concrete Breakout Strength of Anchor in Tension (Sec. 17.4.2)

$$N_b = K_c \lambda_a \sqrt{f_c} c h_{ef}^{1.5} \text{ (Eq. 17.4.2.2a)}$$

K <sub>c</sub>	λ <sub>a</sub>	f <sub>c</sub> (psi)	h <sub>ef</sub> (in)	N <sub>b</sub> (lb)
17.0	1.00	2500	4.000	6800

$$\phi N_{cbg} = \phi (A_{Nc} / A_{Nco}) \psi_{ec,N} \psi_{ed,N} \psi_{c,N} \psi_{cp,N} N_b \text{ (Sec. 17.3.1 \& Eq. 17.4.2.1b)}$$

A <sub>Nc</sub> (in <sup>2</sup> )	A <sub>Nco</sub> (in <sup>2</sup> )	c <sub>a,min</sub> (in)	ψ <sub>ec,N</sub>	ψ <sub>ed,N</sub>	ψ <sub>c,N</sub>	ψ <sub>cp,N</sub>	N <sub>b</sub> (lb)	φ	φN <sub>cbg</sub> (lb)
240.25	144.00	7.25	1.000	1.000	1.00	1.000	6800	0.65	7374

### 6. Adhesive Strength of Anchor in Tension (Sec. 17.4.5)

$$\tau_{k,cr} = \tau_{k,cr,short-term} K_{sat} (f_c / 2,500)^n$$

τ <sub>k,cr</sub> (psi)	f <sub>short-term</sub>	K <sub>sat</sub>	f <sub>c</sub> (psi)	n	τ <sub>k,cr</sub> (psi)
1346	1.00	1.00	2500	0.24	1346

$$N_{ba} = \lambda_a \tau_{cr} \pi d_a h_{ef} \text{ (Eq. 17.4.5.2)}$$

λ <sub>a</sub>	τ <sub>cr</sub> (psi)	d <sub>a</sub> (in)	h <sub>ef</sub> (in)	N <sub>ba</sub> (lb)
1.00	1346	0.38	4.000	6343

$$\phi N_{ag} = \phi (A_{Na} / A_{Na0}) \psi_{ec,Na} \psi_{ed,Na} \psi_{cp,Na} N_{ba} \text{ (Sec. 17.3.1 \& Eq. 17.4.5.1b)}$$

A <sub>Na</sub> (in <sup>2</sup> )	A <sub>Na0</sub> (in <sup>2</sup> )	c <sub>Na</sub> (in)	c <sub>a,min</sub> (in)	ψ <sub>ec,Na</sub>	ψ <sub>ed,Na</sub>	ψ <sub>cp,Na</sub>	N <sub>ba</sub> (lb)	φ	φN <sub>ag</sub> (lb)
198.45	112.09	5.29	7.25	1.000	1.000	1.000	6343	0.55	6176



Company:		Date:	5/14/2018
Engineer:		Page:	5/6
Project:			
Address:			
Phone:			
E-mail:			

**8. Steel Strength of Anchor in Shear (Sec. 17.5.1)**

$V_{sa}$ (lb)	$\phi_{grout}$	$\phi$	$\phi_{grout}\phi V_{sa}$ (lb)
2715	1.0	0.65	1765

**9. Concrete Breakout Strength of Anchor in Shear (Sec. 17.5.2)**

**Shear perpendicular to edge in x-direction:**

$V_{bx} = \min|7(l_e / d_a)^{0.2}\sqrt{d_a}\lambda_a\sqrt{f_c}c_{a1}^{1.5}; 9\lambda_a\sqrt{f_c}c_{a1}^{1.5}|$  (Eq. 17.5.2.2a & Eq. 17.5.2.2b)

$l_e$ (in)	$d_a$ (in)	$\lambda_a$	$f_c$ (psi)	$c_{a1}$ (in)	$V_{bx}$ (lb)
3.00	0.375	1.00	2500	16.75	22270

$\phi V_{cbgx} = \phi (A_{Vc} / A_{Vco})\Psi_{ec,V}\Psi_{ed,V}\Psi_{c,V}\Psi_{h,V}V_{bx}$  (Sec. 17.3.1 & Eq. 17.5.2.1b)

$A_{Vc}$ (in <sup>2</sup> )	$A_{Vco}$ (in <sup>2</sup> )	$\Psi_{ec,V}$	$\Psi_{ed,V}$	$\Psi_{c,V}$	$\Psi_{h,V}$	$V_{bx}$ (lb)	$\phi$	$\phi V_{cbgx}$ (lb)
901.36	1262.53	1.000	0.787	1.000	1.000	22270	0.70	8754

**Shear perpendicular to edge in y-direction:**

$V_{by} = \min|7(l_e / d_a)^{0.2}\sqrt{d_a}\lambda_a\sqrt{f_c}c_{a1}^{1.5}; 9\lambda_a\sqrt{f_c}c_{a1}^{1.5}|$  (Eq. 17.5.2.2a & Eq. 17.5.2.2b)

$l_e$ (in)	$d_a$ (in)	$\lambda_a$	$f_c$ (psi)	$c_{a1}$ (in)	$V_{by}$ (lb)
3.00	0.375	1.00	2500	10.75	11450

$\phi V_{cbgy} = \phi (A_{Vc} / A_{Vco})\Psi_{ec,V}\Psi_{ed,V}\Psi_{c,V}\Psi_{h,V}V_{by}$  (Sec. 17.3.1 & Eq. 17.5.2.1b)

$A_{Vc}$ (in <sup>2</sup> )	$A_{Vco}$ (in <sup>2</sup> )	$\Psi_{ec,V}$	$\Psi_{ed,V}$	$\Psi_{c,V}$	$\Psi_{h,V}$	$V_{by}$ (lb)	$\phi$	$\phi V_{cbgy}$ (lb)
483.75	520.03	1.000	0.947	1.000	1.000	11450	0.70	7057

**Shear parallel to edge in y-direction:**

$V_{bx} = \min|7(l_e / d_a)^{0.2}\sqrt{d_a}\lambda_a\sqrt{f_c}c_{a1}^{1.5}; 9\lambda_a\sqrt{f_c}c_{a1}^{1.5}|$  (Eq. 17.5.2.2a & Eq. 17.5.2.2b)

$l_e$ (in)	$d_a$ (in)	$\lambda_a$	$f_c$ (psi)	$c_{a1}$ (in)	$V_{bx}$ (lb)
3.00	0.375	1.00	2500	13.25	15668

$\phi V_{cbgy} = \phi (2)(A_{Vc} / A_{Vco})\Psi_{ec,V}\Psi_{ed,V}\Psi_{c,V}\Psi_{h,V}V_{bx}$  (Sec. 17.3.1, 17.5.2.1(c) & Eq. 17.5.2.1b)

$A_{Vc}$ (in <sup>2</sup> )	$A_{Vco}$ (in <sup>2</sup> )	$\Psi_{ec,V}$	$\Psi_{ed,V}$	$\Psi_{c,V}$	$\Psi_{h,V}$	$V_{bx}$ (lb)	$\phi$	$\phi V_{cbgy}$ (lb)
608.67	790.03	1.000	1.000	1.000	1.000	15668	0.70	16900

**Shear parallel to edge in x-direction:**

$V_{by} = \min|7(l_e / d_a)^{0.2}\sqrt{d_a}\lambda_a\sqrt{f_c}c_{a1}^{1.5}; 9\lambda_a\sqrt{f_c}c_{a1}^{1.5}|$  (Eq. 17.5.2.2a & Eq. 17.5.2.2b)

$l_e$ (in)	$d_a$ (in)	$\lambda_a$	$f_c$ (psi)	$c_{a1}$ (in)	$V_{by}$ (lb)
3.00	0.375	1.00	2500	7.25	6342

$\phi V_{cbgx} = \phi (2)(A_{Vc} / A_{Vco})\Psi_{ec,V}\Psi_{ed,V}\Psi_{c,V}\Psi_{h,V}V_{by}$  (Sec. 17.3.1, 17.5.2.1(c) & Eq. 17.5.2.1b)

$A_{Vc}$ (in <sup>2</sup> )	$A_{Vco}$ (in <sup>2</sup> )	$\Psi_{ec,V}$	$\Psi_{ed,V}$	$\Psi_{c,V}$	$\Psi_{h,V}$	$V_{by}$ (lb)	$\phi$	$\phi V_{cbgx}$ (lb)
274.59	236.53	1.000	1.000	1.000	1.000	6342	0.70	10307

**10. Concrete Pryout Strength of Anchor in Shear (Sec. 17.5.3)**

$\phi V_{cp} = \phi \min|k_{cp}N_{ag}; k_{cp}N_{cbg}| = \phi \min|k_{cp}(A_{Na} / A_{Na0})\Psi_{ec,Na}\Psi_{ed,Na}\Psi_{cp,Na}N_{ba}; k_{cp}(A_{Nc} / A_{Nco})\Psi_{ec,N}\Psi_{ed,N}\Psi_{c,N}\Psi_{cp,N}N_b|$  (Sec. 17.3.1 & Eq. 17.5.3.1b)

$k_{cp}$	$A_{Na}$ (in <sup>2</sup> )	$A_{Na0}$ (in <sup>2</sup> )	$\Psi_{ed,Na}$	$\Psi_{ec,Na}$	$\Psi_{cp,Na}$	$N_{ba}$ (lb)	$N_a$ (lb)
2.0	198.45	112.09	1.000	1.000	1.000	6343	11230

$A_{Nc}$ (in <sup>2</sup> )	$A_{Nco}$ (in <sup>2</sup> )	$\Psi_{ec,N}$	$\Psi_{ed,N}$	$\Psi_{c,N}$	$\Psi_{cp,N}$	$N_b$ (lb)	$N_{cb}$ (lb)	$\phi$
240.25	144.00	1.000	1.000	1.000	1.000	6800	11345	0.70

Input data and results must be checked for agreement with the existing circumstances, the standards and guidelines must be checked for plausibility.



Company:		Date:	5/14/2018
Engineer:		Page:	6/6
Project:			
Address:			
Phone:			
E-mail:			

$\phi V_{cpq}$  (lb)  
15722

## 11. Results

### Interaction of Tensile and Shear Forces (Sec. R17.6)

Tension	Factored Load, $N_{ua}$ (lb)	Design Strength, $\phi N_n$ (lb)	Ratio	Status
Steel	1170	3394	0.34	Pass
Concrete breakout	4680	7374	0.63	Pass
<b>Adhesive</b>	<b>4680</b>	<b>6176</b>	<b>0.76</b>	<b>Pass (Governs)</b>

Shear	Factored Load, $V_{ua}$ (lb)	Design Strength, $\phi V_n$ (lb)	Ratio	Status
<b>Steel</b>	<b>744</b>	<b>1765</b>	<b>0.42</b>	<b>Pass (Governs)</b>
T Concrete breakout x+	160	8754	0.02	Pass
T Concrete breakout y-	2970	7057	0.42	Pass
Concrete breakout x+	1485	16900	0.09	Pass
Concrete breakout y-	80	10307	0.01	Pass
Concrete breakout, combined	-	-	0.42	Pass
Pryout	2974	15722	0.19	Pass

Interaction check	$(N_{ua}/\phi N_{ua})^{5/3}$	$(V_{ua}/\phi V_{ua})^{5/3}$	Combined Ratio	Permissible	Status
Sec. R17.6	0.63	0.24	86.7%	1.0	Pass

**SET-3G w/ 3/8"Ø F1554 Gr. 36 with hef = 4.000 inch meets the selected design criteria.**

## 12. Warnings

- Designer must exercise own judgement to determine if this design is suitable.
- Refer to manufacturer's product literature for hole cleaning and installation instructions.



JOB NO.: U2716-0276-211

DESIGNED: STB

---

# Framing Analysis

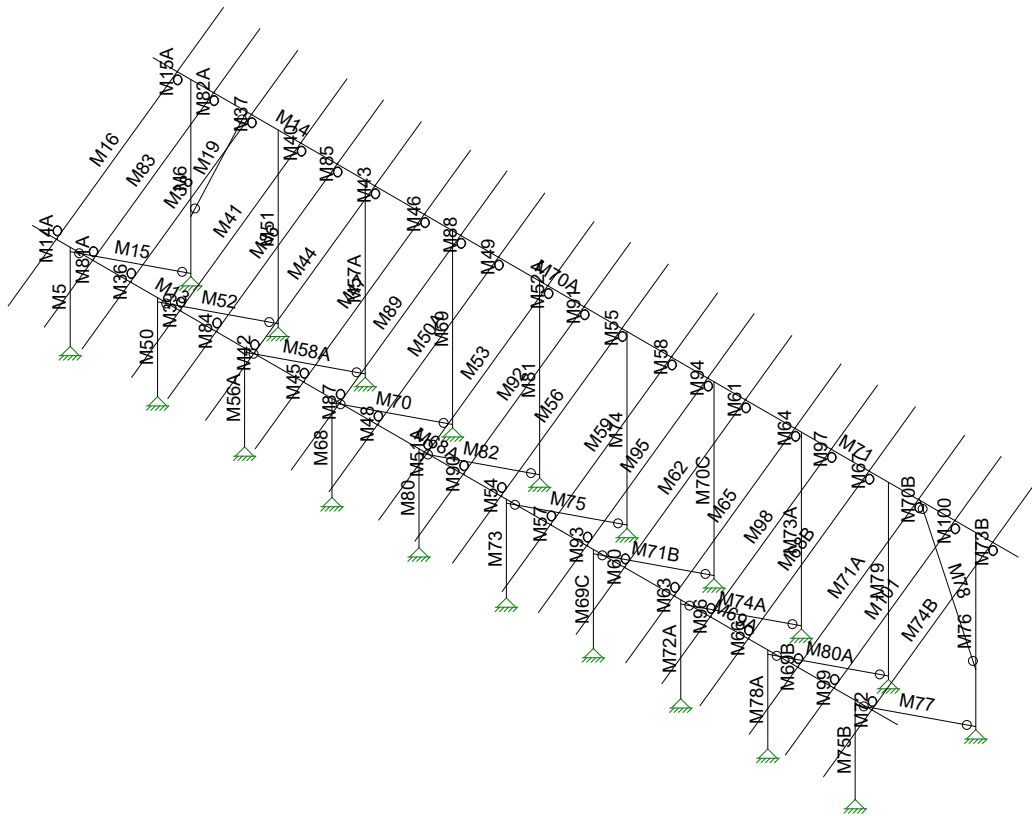

Vector Structural Engineeri...

STB

U2716.0276.211

Ground Mount

SK - 3

Mar 30, 2021 at 4:23 PM

Sunmodo Sunturf A9 v3 85x45.r3d

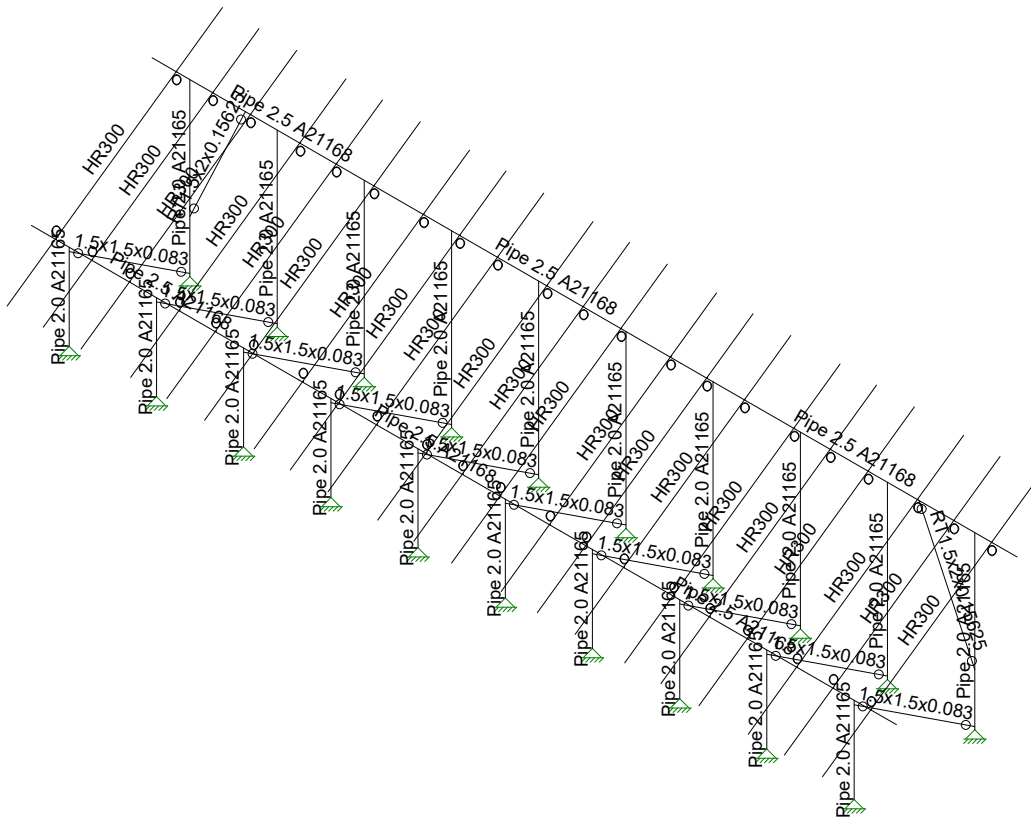

Vector Structural Engineeri...  
STB  
U2716.0276.211

Ground Mount

SK - 4  
Mar 30, 2021 at 4:23 PM  
Sunmodo Sunturf A9 v3 85x45.r3d

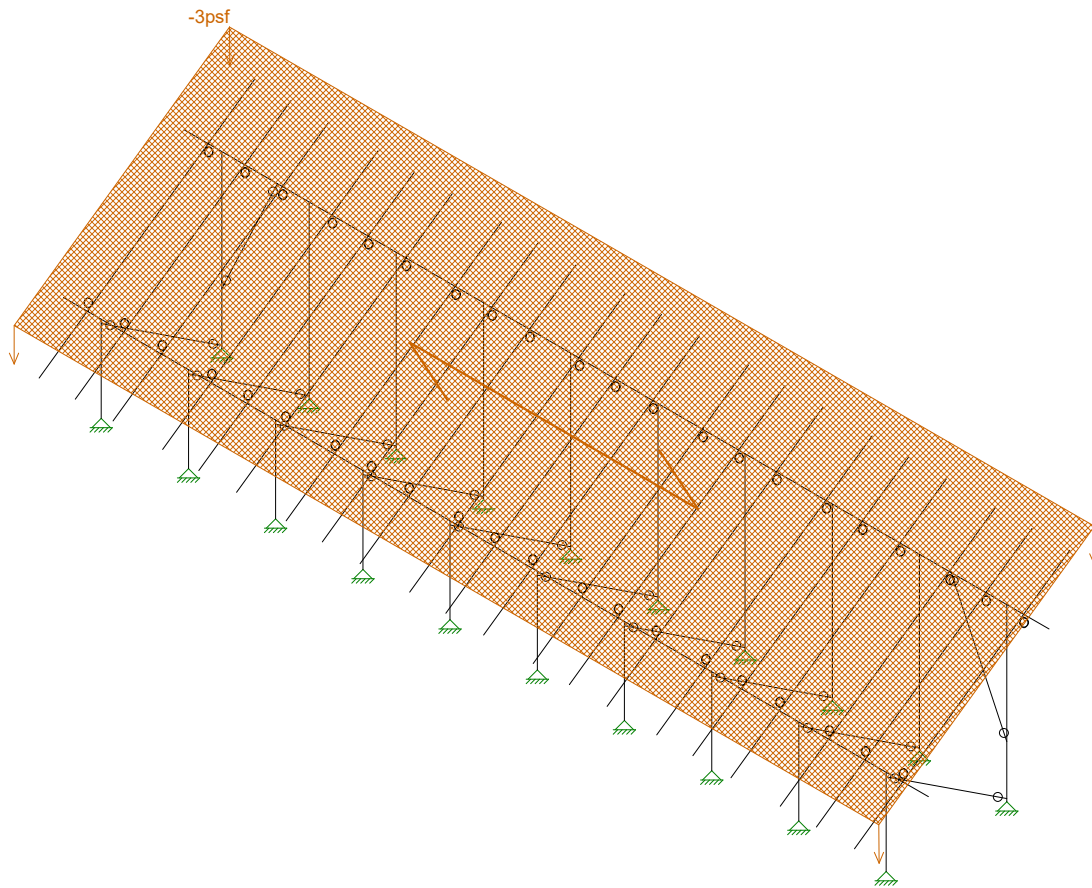

Loads: BLC 2, Solar Panel Weight

Vector Structural Engineeri...	Ground Mount	SK - 5
STB		Mar 30, 2021 at 4:23 PM
U2716.0276.211		Sunmodo Sunturf A9 v3 85x45.r3d

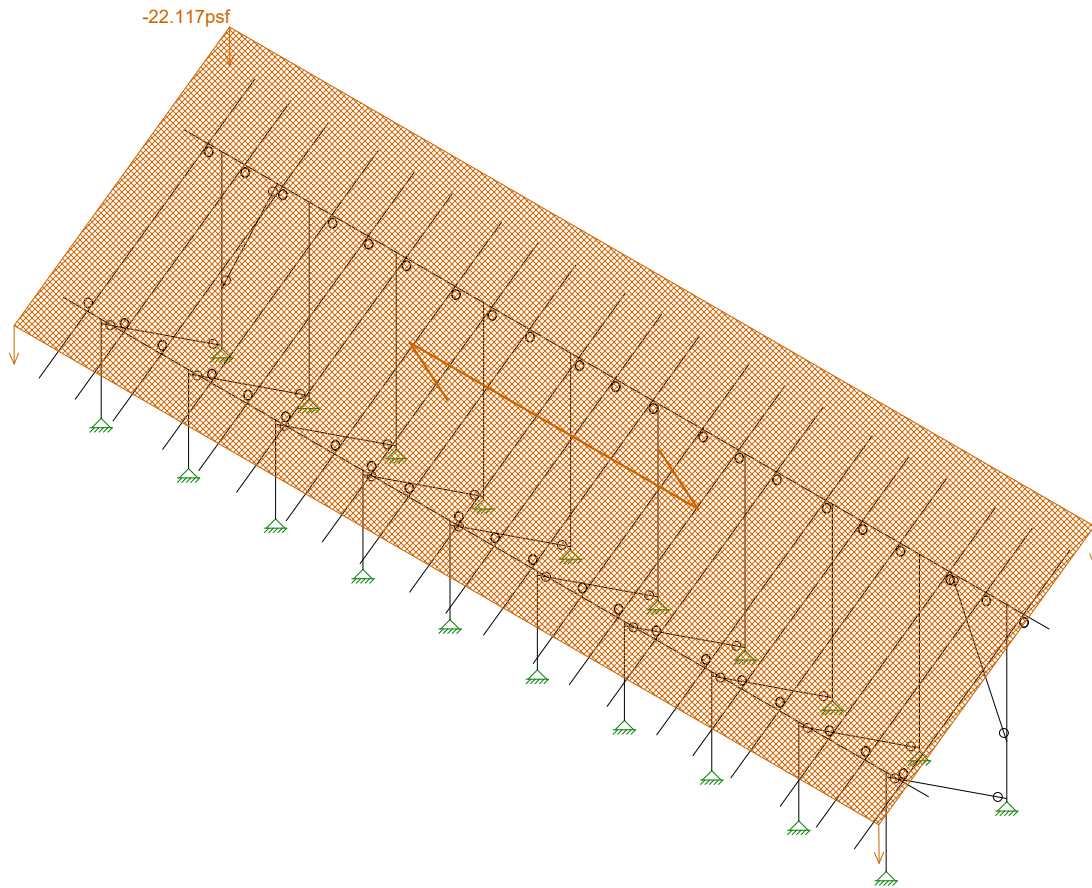

Loads: BLC 3, Roof Live/Snow

Vector Structural Engineeri...	Ground Mount	SK - 6
STB		Mar 30, 2021 at 4:23 PM
U2716.0276.211		Sunmodo Sunturf A9 v3 85x45.r3d

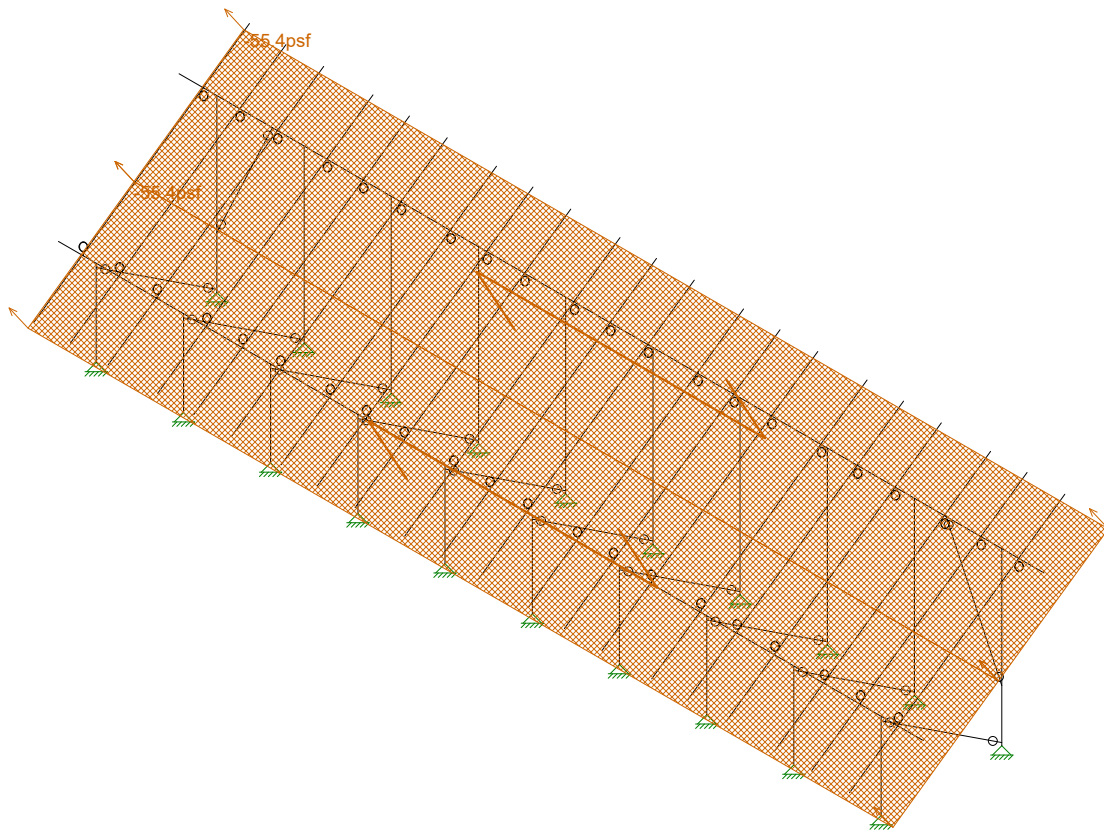

Loads: BLC 4, Wind A 0 deg

Vector Structural Engineeri..	Ground Mount	SK - 7
STB		Mar 30, 2021 at 4:24 PM
U2716.0276.211		Sunmodo Sunturf A9 v3 85x45.r3d

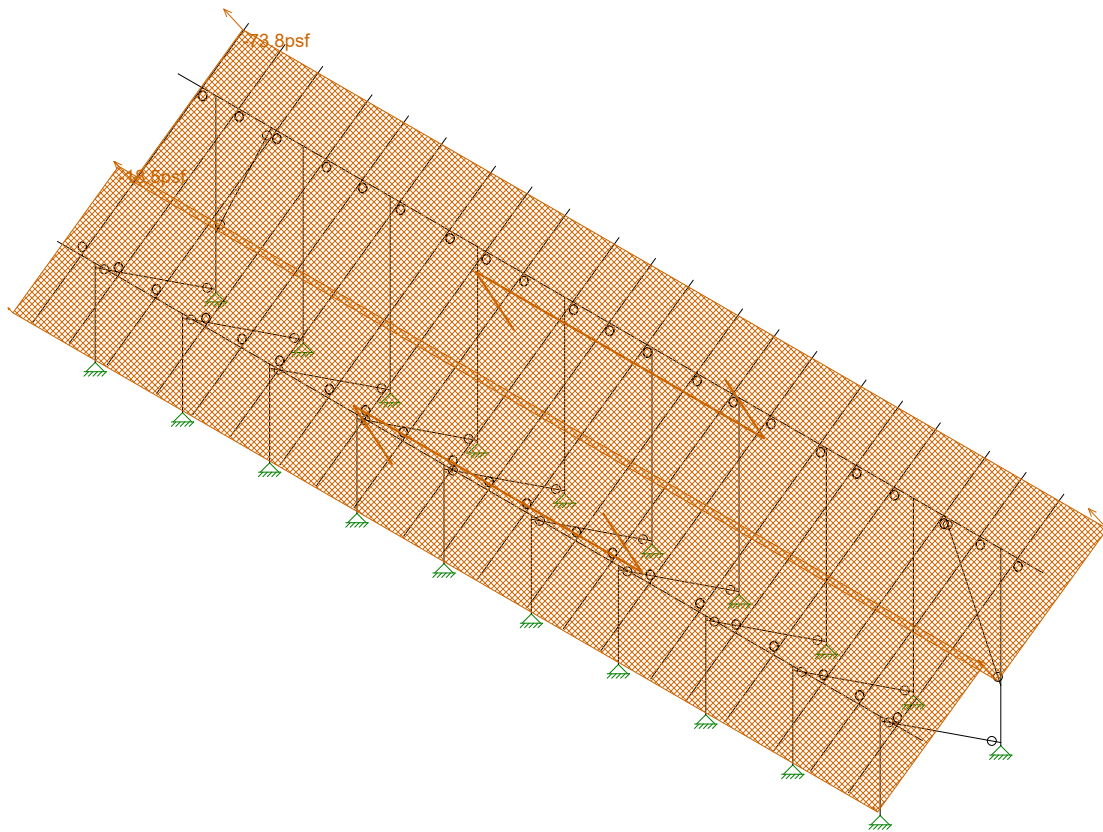

Loads: BLC 5, Wind B 0 deg

Vector Structural Engineeri..	Ground Mount	SK - 8
STB		Mar 30, 2021 at 4:24 PM
U2716.0276.211		Sunmodo Sunturf A9 v3 85x45.r3d

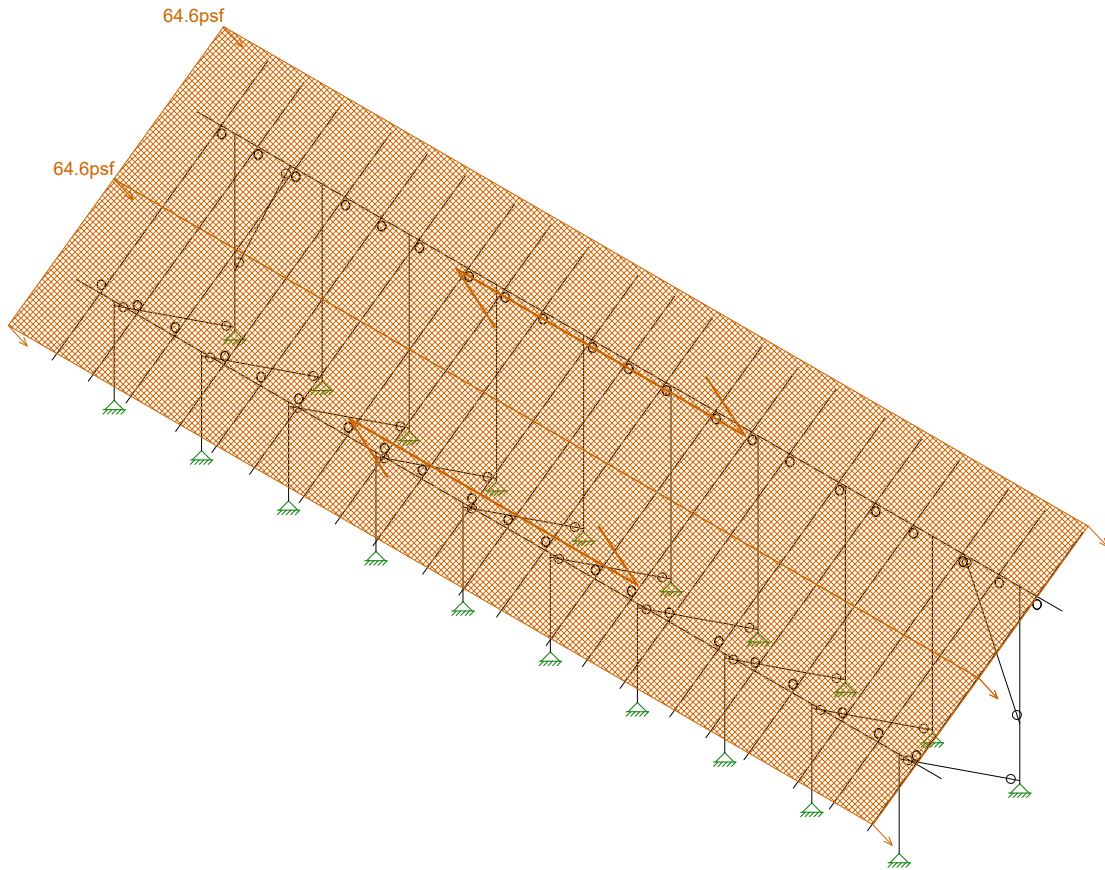

Loads: BLC 6, Wind A 180 deg

Vector Structural Engineeri...  
STB  
U2716.0276.211

Ground Mount

SK - 9

Mar 30, 2021 at 4:24 PM

Sunmodo Sunturf A9 v3 85x45.r3d

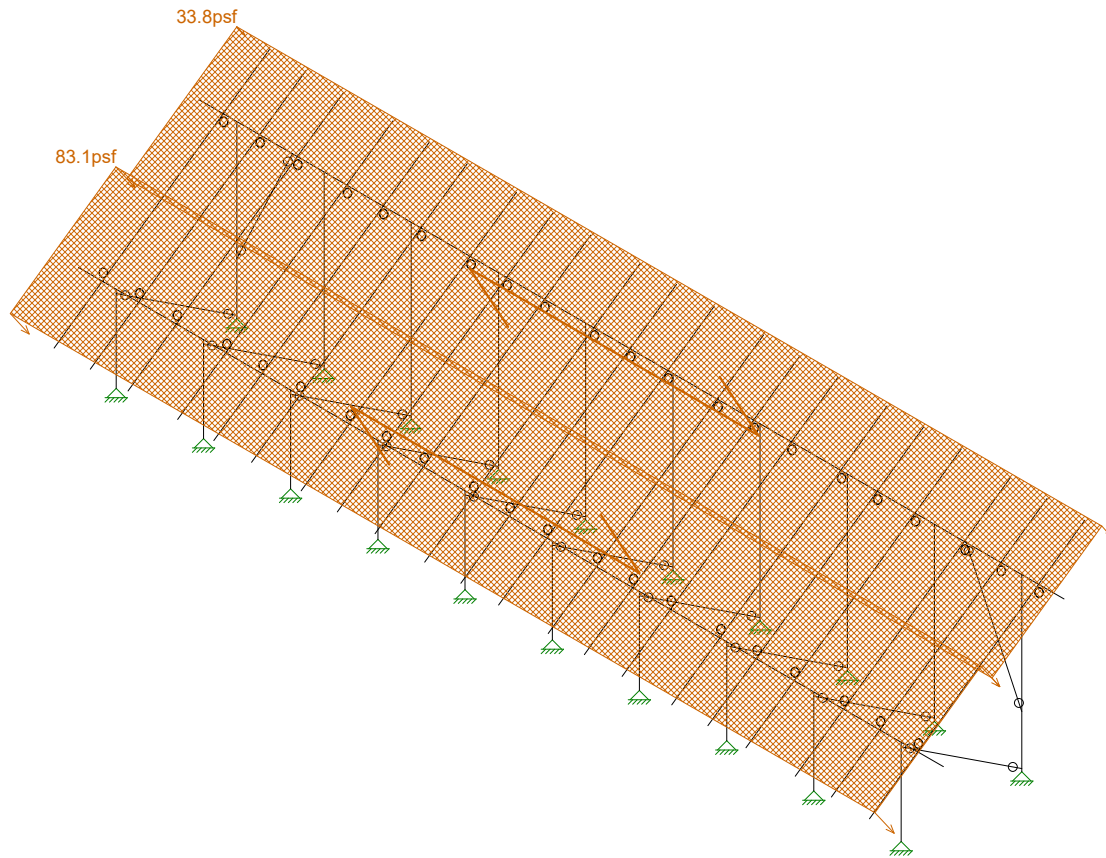

Loads: BLC 7, Wind B 180 deg

Vector Structural Engineeri...  
STB  
U2716.0276.211

Ground Mount

SK - 10

Mar 30, 2021 at 4:24 PM

Sunmodo Sunturf A9 v3 85x45.r3d



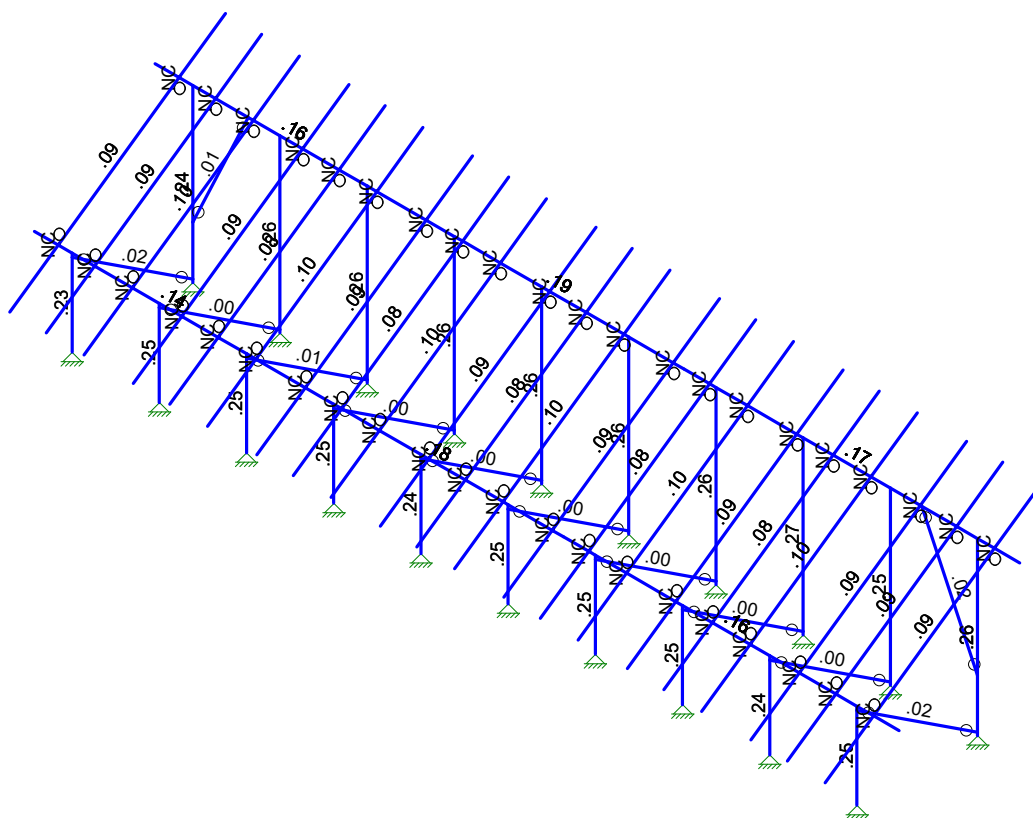
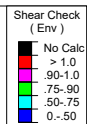

Member Shear Checks Displayed (Enveloped)  
Envelope Only Solution

Vector Structural Engineeri...	Ground Mount	SK - 2
STB		Mar 30, 2021 at 4:23 PM
U2716.0276.211		Sunmodo Sunturf A9 v3 85x45.r3d



**(Global) Model Settings**

Display Sections for Member Calcs	5
Max Internal Sections for Member Calcs	97
Include Shear Deformation?	Yes
Increase Nailing Capacity for Wind?	Yes
Include Warping?	Yes
Trans Load Btwn Intersecting Wood Wall?	Yes
Area Load Mesh (in^2)	144
Merge Tolerance (in)	.12
P-Delta Analysis Tolerance	0.50%
Include P-Delta for Walls?	Yes
Automatically Iterate Stiffness for Walls?	Yes
Max Iterations for Wall Stiffness	3
Gravity Acceleration (in/sec^2)	386.4
Wall Mesh Size (in)	24
Eigensolution Convergence Tol. (1.E-)	4
Vertical Axis	Y
Global Member Orientation Plane	XZ
Static Solver	Sparse Accelerated
Dynamic Solver	Accelerated Solver

Hot Rolled Steel Code	AISC 15th(360-16): ASD
Adjust Stiffness?	Yes(Iterative)
RISAConnection Code	AISC 15th(360-16): ASD
Cold Formed Steel Code	AISI S100-16: ASD
Wood Code	AWC NDS-18: ASD
Wood Temperature	< 100F
Concrete Code	ACI 318-14
Masonry Code	None
Aluminum Code	AA ADM1-15: ASD - Building
Stainless Steel Code	AISC 14th(360-10): ASD
Adjust Stiffness?	Yes(Iterative)

Number of Shear Regions	4
Region Spacing Increment (in)	4
Biaxial Column Method	Exact Integration
Parame Beta Factor (PCA)	.65
Concrete Stress Block	Rectangular
Use Cracked Sections?	Yes
Use Cracked Sections Slab?	No
Bad Framing Warnings?	No
Unused Force Warnings?	Yes
Min 1 Bar Diam. Spacing?	No
Concrete Rebar Set	REBAR SET ASTMA615
Min % Steel for Column	1
Max % Steel for Column	8



**(Global) Model Settings, Continued**

Seismic Code	ASCE 7-16
Seismic Base Elevation (in)	15600
Add Base Weight?	Yes
Ct X	.02
Ct Z	.02
T X (sec)	Not Entered
T Z (sec)	Not Entered
R X	3
R Z	3
Ct Exp. X	.75
Ct Exp. Z	.75
SD1	1
SDS	1
S1	1
TL (sec)	5
Risk Cat	I or II
Drift Cat	Other
Om Z	1
Om X	1
Cd Z	4
Cd X	4
Rho Z	1
Rho X	1

**Hot Rolled Steel Properties**

	Label	E [ksi]	G [ksi]	Nu	Therm (/1E5 F)	Density[lb/ft^3]	Yield[psi]	Ry	Fu[psi]	Rt
1	A992	29000	11154	.3	.65	490	50000	1.1	65000	1.1
2	A36 Gr.36	29000	11154	.3	.65	490	36000	1.5	58000	1.2
3	A572 Gr.50	29000	11154	.3	.65	490	50000	1.1	65000	1.1
4	A500 Gr.B R...	29000	11154	.3	.65	527	42000	1.4	58000	1.3
5	A500 Gr.B Re...	29000	11154	.3	.65	527	46000	1.4	58000	1.3
6	A53 Gr.B	29000	11154	.3	.65	490	35000	1.6	60000	1.2
7	A1085	29000	11154	.3	.65	490	50000	1.4	65000	1.3

**Aluminum Properties**

	Label	E [ksi]	G [ksi]	Nu	Therm (...Density[... Table B.4	kt	Ftu[psi]	Fty[psi]	Fcy[psi]	Fsu[psi]	Ct
1	3003-H14	10100	3787.5	.33	1.3 172.8 Table B.4-1	1	19000	16000	13000	12000	141
2	6061-T6	10100	3787.5	.33	1.3 172.8 Table B.4-2	1	38000	35000	35000	24000	141
3	6063-T5	10100	3787.5	.33	1.3 172.8 Table B.4-2	1	22000	16000	16000	13000	141
4	6063-T6	10100	3787.5	.33	1.3 172.8 Table B.4-2	1	30000	25000	25000	19000	141
5	5052-H34	10200	3787.5	.33	1.3 172.8 Table B.4-1	1	34000	26000	24000	20000	141
6	6061-T6 W	10100	3787.5	.33	1.3 172.8 Table B.4-1	1	24000	15000	15000	15000	141
7	6005-T5	10100	3787.5	.33	1.3 172.8 Table B.4-1	1	38000	35000	35000	24000	141

**Hot Rolled Steel Section Sets**

	Label	Shape	Type	Design List	Material	Design R...	A [in2]	Iyy [in4]	Izz [in4]	J [in4]
1	Post	Pipe 2.0 A21165	Column	Pipe	A572 Gr.50	Typical	.776	.499	.499	.998
2	Cross Beam	Pipe 2.5 A21168	Beam	Wide Flange	A572 Gr.50	Typical	.947	.907	.907	1.814
3	Diagonal Brace	1.5x1.5x0.083	HBrace	SquareTube	A572 Gr.50	Typical	.47	.158	.158	.236



Company : Vector Structural Engineering  
 Designer : STB  
 Job Number : U2716.0276.211  
 Model Name : Ground Mount

Mar 30, 2021  
 4:24 PM  
 Checked By: \_\_\_\_\_

### Aluminum Section Sets

	Label	Shape	Type	Design List	Material	Design R...	A [in2]	Iyy [in4]	Izz [in4]	J [in4]
1	AL Posts	2.375ODX0.188	Column	Pipe	6005-T5	Typical	1.29	.778	.778	1.54
2	AL Brace	RT1.5x2x0.15625	VBrace	Rectangular Tubes	6005-T5	Typical	.996	.327	.524	.602
3	AL Rails	HR300	Beam	Rectangular Tubes	6005-T5	Typical	.74	.253	.727	.578
4	AL Cross Beam	Cross Rail	Beam	Rectangular Tubes	6005-T5	Typical	1.909	1.97	4.366	4.017

### Member Area Loads (BLC 2 : Solar Panel Weight)

	Joint A	Joint B	Joint C	Joint D	Direction	Distribution	Magnitude[psf]
1	N197	N200	N199	N196	Y	A-B	-3

### Member Area Loads (BLC 3 : Roof Live/Snow)

	Joint A	Joint B	Joint C	Joint D	Direction	Distribution	Magnitude[psf]
1	N197	N200	N199	N196	PY	A-B	-27

### Member Area Loads (BLC 4 : Wind A 0 deg)

	Joint A	Joint B	Joint C	Joint D	Direction	Distribution	Magnitude[psf]
1	N197	N200	N201	N198	Perp	A-B	-55.4
2	N198	N201	N199	N196	Perp	A-B	-55.4

### Member Area Loads (BLC 5 : Wind B 0 deg)

	Joint A	Joint B	Joint C	Joint D	Direction	Distribution	Magnitude[psf]
1	N197	N200	N201	N198	Perp	A-B	-73.8
2	N198	N201	N199	N196	Perp	A-B	-18.5

### Member Area Loads (BLC 6 : Wind A 180 deg)

	Joint A	Joint B	Joint C	Joint D	Direction	Distribution	Magnitude[psf]
1	N197	N200	N201	N198	Perp	A-B	64.6
2	N198	N201	N199	N196	Perp	A-B	64.6

### Member Area Loads (BLC 7 : Wind B 180 deg)

	Joint A	Joint B	Joint C	Joint D	Direction	Distribution	Magnitude[psf]
1	N197	N200	N201	N198	Perp	A-B	33.8
2	N198	N201	N199	N196	Perp	A-B	83.1

### Basic Load Cases

	BLC Description	Category	X Gravity	Y Gravity	Z Gravity	Joint	Point	Distributed	Area(M...Surface...
1	Self Weight	DL		-1.05					
2	Solar Panel Weight	DL							1
3	Roof Live/Snow	RLL							1
4	Wind A 0 deg	OL1							2
5	Wind B 0 deg	OL2							2
6	Wind A 180 deg	OL3							2
7	Wind B 180 deg	OL4							2
8	BLC 2 Transient Area ...	None						45	
9	BLC 3 Transient Area ...	None						45	
10	BLC 4 Transient Area ...	None						148	
11	BLC 5 Transient Area ...	None						148	
12	BLC 6 Transient Area ...	None						148	
13	BLC 7 Transient Area ...	None						148	





Company : Vector Structural Engineering  
 Designer : STB  
 Job Number : U2716.0276.211  
 Model Name : Ground Mount

Mar 30, 2021  
 4:24 PM  
 Checked By: \_\_\_\_\_

**Envelope Joint Reactions (Continued)**

Joint	X [lb]	LC	Y [lb]	LC	Z [lb]	LC	MX [lb-ft]	LC MY [lb-ft]	LC	MZ [lb-ft]	LC
38	min -1.967	9	-2503.691	12	-1462...	3	0	1	0	1	0
39	N162A max 1.66	11	1575.977	8	65.573	3	0	14	0	14	0
40	min -5.022	10	-424.252	13	-76.367	5	0	1	0	1	0
41	Totals: max .004	11	33660.577	9	16629...	5					
42	min -.01	9	-18302.591	11	-1426...	3					

**Envelope AISC 15th(360-16): ASD Steel Code Checks**

Member	Shape	Code Check	Loc[in]	LC Shear	Loc[in]	Dir	LC Pnc/om	Pnt/om [lb]	Mny/om	Mnz/om	Cb	Eqn	
1	M5	Pipe 2.0 A2...	.264	56.574	5	.232	56.574	5	15634.075	23232.186	1397.505	1397.505	1...H1-1b
2	M6	Pipe 2.0 A2...	.655	1.223	5	.243	0	5	5439	23232.186	1397.505	1397.505	1...H1-1a
3	M13	Pipe 2.5 A2...	.492	86.25	10	.144	147....	6	11641.036	28358.413	2081.747	2081.747	1...H1-1b
4	M14	Pipe 2.5 A2...	.481	86.25	9	.157	147....	9	11641.036	28358.413	2081.747	2081.747	1...H1-1b
5	M15	1.5x1.5x0.083	.838	51.711	5	.023	0	y 9	2408.78	14085.15	624.421	624.421	1...H1-1a
6	M80	Pipe 2.0 A2...	.276	56.574	5	.245	56.574	5	15634.075	23232.186	1397.505	1397.505	1...H1-1b
7	M81	Pipe 2.0 A2...	.686	1.223	5	.259	0	5	5439	23232.186	1397.505	1397.505	1...H1-1a
8	M82	1.5x1.5x0.083	.897	51.711	5	.004	99.285	y 8	2408.78	14085.15	624.421	624.421	1...H1-1a
9	M50	Pipe 2.0 A2...	.274	56.574	5	.248	56.574	5	15634.075	23232.186	1397.505	1397.505	1...H1-1b
10	M51	Pipe 2.0 A2...	.679	1.223	5	.262	0	5	5439	23232.186	1397.505	1397.505	1...H1-1a
11	M52	1.5x1.5x0.083	.906	51.711	5	.002	0	y 5	2408.78	14085.15	624.421	624.421	1...H1-1a
12	M56A	Pipe 2.0 A2...	.278	56.574	5	.251	56.574	5	15634.075	23232.186	1397.505	1397.505	1...H1-1b
13	M57A	Pipe 2.0 A2...	.701	1.223	5	.264	0	5	5439	23232.186	1397.505	1397.505	1...H1-1a
14	M58A	1.5x1.5x0.083	.915	51.711	5	.006	0	y 5	2408.78	14085.15	624.421	624.421	1...H1-1a
15	M68	Pipe 2.0 A2...	.278	56.574	5	.248	56.574	5	15634.075	23232.186	1397.505	1397.505	1...H1-1b
16	M69	Pipe 2.0 A2...	.696	1.223	5	.262	0	5	5439	23232.186	1397.505	1397.505	1...H1-1a
17	M70	1.5x1.5x0.083	.908	51.711	5	.003	99.285	y 8	2408.78	14085.15	624.421	624.421	1...H1-1a
18	M68A	Pipe 2.5 A2...	.393	82.5	10	.177	140....	6	11641.036	28358.413	2081.747	2081.747	2...H1-1b
19	M69A	Pipe 2.5 A2...	.478	141....	10	.158	21.656	6	11641.036	28358.413	2081.747	2081.747	2...H1-1b
20	M70A	Pipe 2.5 A2...	.374	82.5	9	.192	140....	9	11641.036	28358.413	2081.747	2081.747	2...H1-1b
21	M71	Pipe 2.5 A2...	.470	202....	9	.173	21.656	9	11641.036	28358.413	2081.747	2081.747	2...H1-1b
22	M73	Pipe 2.0 A2...	.277	56.574	5	.248	56.574	5	15634.075	23232.186	1397.505	1397.505	1...H1-1b
23	M74	Pipe 2.0 A2...	.694	1.223	5	.262	0	5	5439	23232.186	1397.505	1397.505	1...H1-1a
24	M75	1.5x1.5x0.083	.909	51.711	5	.004	0	y 10	2408.78	14085.15	624.421	624.421	1...H1-1a
25	M69C	Pipe 2.0 A2...	.278	56.574	5	.246	56.574	5	15634.075	23232.186	1397.505	1397.505	1...H1-1b
26	M70C	Pipe 2.0 A2...	.691	1.223	5	.260	0	5	5439	23232.186	1397.505	1397.505	1...H1-1a
27	M71B	1.5x1.5x0.083	.901	51.711	5	.003	0	y 8	2408.78	14085.15	624.421	624.421	1...H1-1a
28	M72A	Pipe 2.0 A2...	.278	56.574	5	.252	56.574	5	15634.075	23232.186	1397.505	1397.505	1...H1-1b
29	M73A	Pipe 2.0 A2...	.705	1.223	5	.266	0	5	5439	23232.186	1397.505	1397.505	1...H1-1a
30	M74A	1.5x1.5x0.083	.920	51.711	5	.005	99.285	y 5	2408.78	14085.15	624.421	624.421	1...H1-1a
31	M75B	Pipe 2.0 A2...	.275	56.574	5	.250	56.574	5	15634.075	23232.186	1397.505	1397.505	1...H1-1b
32	M76	Pipe 2.0 A2...	.707	1.223	5	.263	0	5	5439	23232.186	1397.505	1397.505	1...H1-1a
33	M77	1.5x1.5x0.083	.904	51.711	5	.018	0	y 9	2408.78	14085.15	624.421	624.421	1...H1-1a
34	M78A	Pipe 2.0 A2...	.275	56.574	5	.240	56.574	5	15634.075	23232.186	1397.505	1397.505	1...H1-1b
35	M79	Pipe 2.0 A2...	.659	1.223	5	.255	0	5	5439	23232.186	1397.505	1397.505	1...H1-1a
36	M80A	1.5x1.5x0.083	.882	51.711	5	.003	0	y 2	2408.78	14085.15	624.421	624.421	1...H1-1a

**Envelope AA ADM1-15: ASD - Building Aluminum Code Checks**

Member	Shape	Code C...	Loc[in]	LC Shear	Loc[in]	Dir	LC Pnc/O...	Pnt/Om...	Mny/O...	Mnz/O...	Vny/O...	Vnz/O...	Cb	Eqn	
1	M19	RT1.5x2x...	.087	56.241	9	.011	0	z 5	2073.828	19411....	770.742	927.083	5889.423	3966.346	1...H-1-1
2	M16	HR300	.754	41.486	10	.092	41.486	y 10	3634.437	14429....	560.361	934.132	5656.689	2605.145	2...H-1-1
3	M38	HR300	.790	41.486	10	.097	41.486	y 10	3634.437	14429....	560.361	934.132	5656.689	2605.145	2...H-1-1
4	M41	HR300	.775	41.486	10	.095	41.486	y 10	3634.437	14429....	560.361	934.132	5656.689	2605.145	2...H-1-1
5	M44	HR300	.796	41.486	10	.096	41.486	y 10	3634.437	14429....	560.361	934.132	5656.689	2605.145	2...H-1-1
6	M47	HR300	.785	41.486	10	.095	41.486	y 10	3634.437	14429....	560.361	934.132	5656.689	2605.145	2...H-1-1
7	M50A	HR300	.799	41.486	10	.096	41.486	y 10	3634.437	14429....	560.361	934.132	5656.689	2605.145	2...H-1-1



Company : Vector Structural Engineering  
 Designer : STB  
 Job Number : U2716.0276.211  
 Model Name : Ground Mount

Mar 30, 2021  
 4:24 PM  
 Checked By: \_\_\_\_\_

**Envelope AA ADM1-15: ASD - Building Aluminum Code Checks (Continued)**

Member	Shape	Code C...	Loc[fin]	LC	Shear ...	Loc[fin]	Dir	LC	Pnc/O...	Pnt/Om...	Mny/O...	Mnz/O...	Vny/O...	Vnz/O...	Cb	Eqn
8	M53	HR300	.794	141.4...	12	.095	41.486	y	10	3634.437	14429....	560.361	934.132	5656.689	2605.145	1...H.1-1
9	M56	HR300	.814	141.4...	12	.096	41.486	y	10	3634.437	14429....	560.361	934.132	5656.689	2605.145	1...H.1-1
10	M59	HR300	.802	41.486	10	.094	41.486	y	10	3634.437	14429....	560.361	934.132	5656.689	2605.145	2...H.1-1
11	M62	HR300	.799	41.486	10	.096	41.486	y	10	3634.437	14429....	560.361	934.132	5656.689	2605.145	2...H.1-1
12	M65	HR300	.783	41.486	10	.094	41.486	y	10	3634.437	14429....	560.361	934.132	5656.689	2605.145	2...H.1-1
13	M68B	HR300	.797	41.486	10	.096	41.486	y	10	3634.437	14429....	560.361	934.132	5656.689	2605.145	2...H.1-1
14	M71A	HR300	.779	41.486	10	.095	41.486	y	10	3634.437	14429....	560.361	934.132	5656.689	2605.145	2...H.1-1
15	M74B	HR300	.770	41.486	10	.094	41.486	y	10	3634.437	14429....	560.361	934.132	5656.689	2605.145	2...H.1-1
16	M78	RT1.5x2x...	.093	56.308	9	.016	0	z	5	2068.941	19411....	770.742	927.083	5889.423	3966.346	1...H.1-1
17	M83	HR300	.739	41.486	6	.088	41.486	y	10	3634.437	14429....	560.361	934.132	5656.689	2605.145	2...H.1-1
18	M86	HR300	.679	41.486	10	.082	41.486	y	10	3634.437	14429....	560.361	934.132	5656.689	2605.145	2...H.1-1
19	M89	HR300	.688	141.4...	12	.082	41.486	y	10	3634.437	14429....	560.361	934.132	5656.689	2605.145	1...H.1-1
20	M92	HR300	.719	41.486	10	.082	41.486	y	10	3634.437	14429....	560.361	934.132	5656.689	2605.145	2...H.1-1
21	M95	HR300	.704	141.4...	12	.082	41.486	y	10	3634.437	14429....	560.361	934.132	5656.689	2605.145	1...H.1-1
22	M98	HR300	.694	41.486	10	.082	41.486	y	10	3634.437	14429....	560.361	934.132	5656.689	2605.145	2...H.1-1
23	M101	HR300	.737	41.486	6	.087	41.486	y	10	3634.437	14429....	560.361	934.132	5656.689	2605.145	2...H.1-1

NOTES: UNLESS OTHERWISE SPECIFIED  
 1. DIMENSIONS SHOWN ARE INCHES [MILLIMETERS].

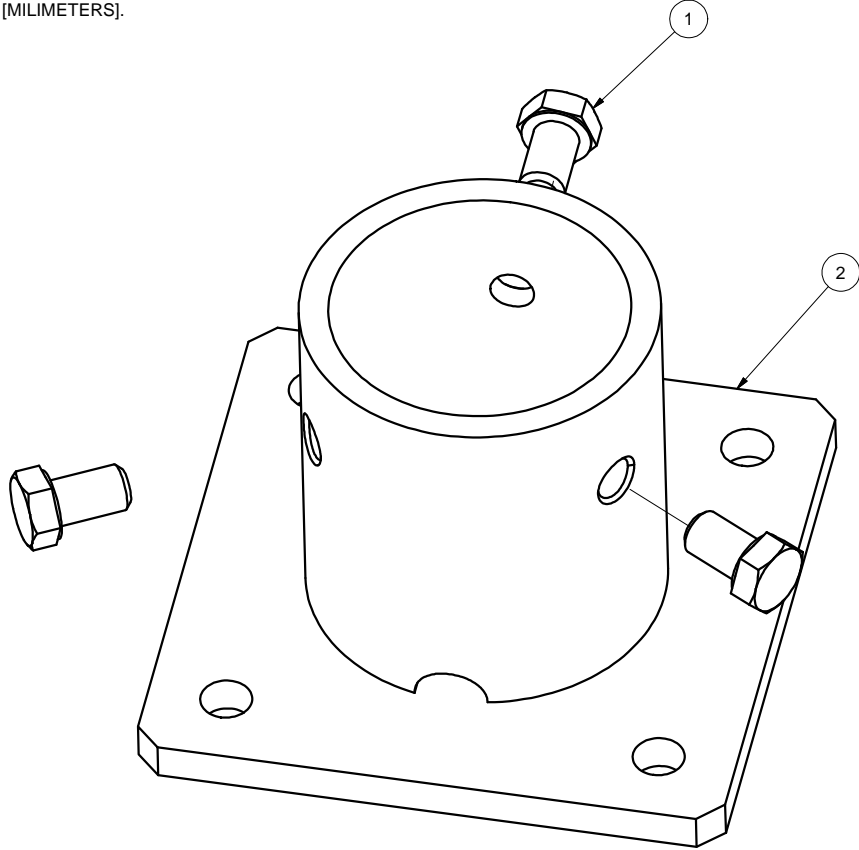

REVISIONS			
REV	DESCRIPTION	BY	DATE
A	INITIAL RELEASE	LWF	10/20/2016

2	A21120-001	2" PIPE BASE	1
1	B15018-011	HEX CAP SCREW 3/8-16 X 5/8	3
ITEM	PART NUMBER	DESCRIPTION	QTY
MATERIAL		SEE NOTES	
Third Angle Projection:			
GENERAL SPECIFICATIONS		<b>Sunmodo Corp.</b> 1905 E 5TH STREET, STE A, VANCOUVER, WA 98661	
Tolerances		TITLE	
X.XXX ±0.01 [0.25mm] X.XX ±0.02 [0.50mm] X.X ±0.039 [1.0mm] Unless otherwise spec'd		2" PIPE BASE KIT	
DRAWN BY		DATE	
LWF		10/20/2016	
CHECKED BY		DRAWING NUMBER	
		B K10268-001	
APPROVALS		SCALE: NONE	
		SHEET 1 of 1	

THIS DRAWING IS CONFIDENTIAL PROPERTY OF SUNMODO AND ITS CONTENTS MAY NOT BE DISCLOSED WITHOUT THE PRIOR WRITTEN CONSENT OF SUNMODO CORP.

NOTES: UNLESS OTHERWISE SPECIFIED

1. DIMENSIONS SHOWN ARE INCHES [MILIMETERS].
2. MATERAIL: ALUMINUM 6005-T5.  
FINISH: CLEAR ANODIZED 10  $\mu$ m THICK.
3. THE UNSPECIFIED DIMENSIONS ARE SPECIFIED BY 2D CAD FILE.

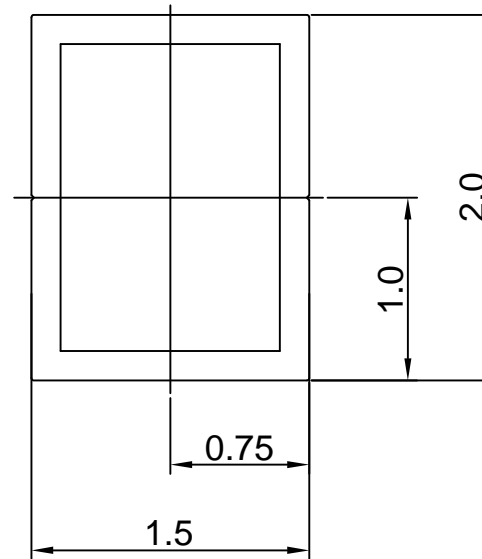

## Section properties:

Weight: 1.156 lbs/ft

Area: 0.992 in<sup>2</sup>

Perimeter: 12.601 in

Bounding Box: X: -1.000,1.000

Y: -0.750, 0.750

Centroid:(0.000,0.000)

Moments of Inertia(in<sup>4</sup>): I<sub>x</sub>=0.506,I<sub>y</sub>=0.322

Section modulus in bending(in<sup>3</sup>): W<sub>x</sub>=0.675,W<sub>y</sub>=0.322

Radii of Gyration: X: 0.714, Y: 0.570

MATERIAL		SEE NOTES	
Third Angle Projection:			
<b>GENERAL SPECIFICATIONS</b> All Dimensions in inches [millimeters] <b>Tolerances</b> X.XXX ± 0.01 [0.25mm] X.XX ± 0.02 [0.50mm] X.X ± 0.039 [1.0mm] Unless otherwise specified.			
DRAWN BY		DATE	
zcg		03/12/2014	
CHECKED BY			
APPROVALS			
		<b>Sunmodo Corp.</b> 1905 E 5TH STREET, SUITE A, VANCOUVER, WA 98661	
		TITLE 1.5X2 AL TUBE BRACE EXTRUSION	
		DRAWING NUMBER A20164	
		SCALE: NONE	
		SHEET 1 of 1	

REVISIONS			
REV	DESCRIPTION	BY	DATE
A	ADDED BOTTOM CHANNEL & CHANGED ONE 3/8 CHANNEL TO 1/4	zcg	02/21/2013

NOTES: UNLESS OTHERWISE SPECIFIED

1. DIMENSIONS SHOWN ARE INCHES [MILIMETERS].
2. MATERAIL: ALUMINUM 6005-T5.  
FINISH: CLEAR ANODIZED 15  $\mu$ m THICK.
3. THE UNSPECIFIED DIMENSIONS ARE SPECIFIED BY 2D CAD FILE.

2X 1/4 BOLT SLOT

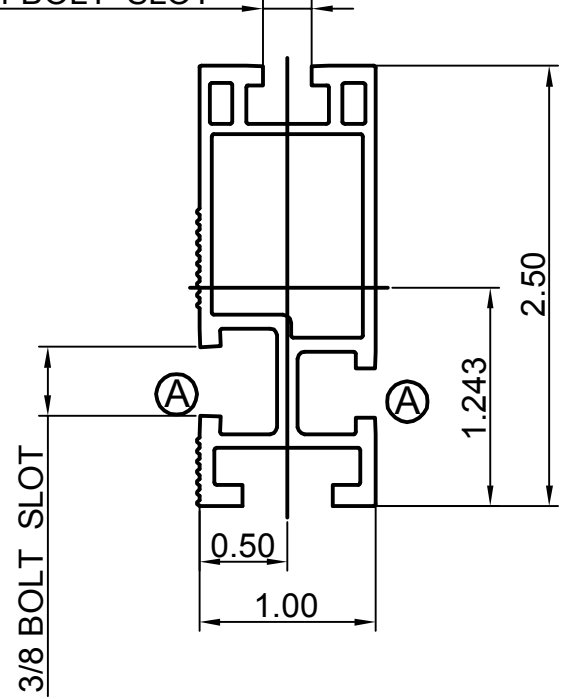

### Section properties:

Weight: 0.850 lbs/ft  
 Area: 0.723 in<sup>2</sup>  
 Perimeter: 17.325 in  
 Bounding Box: X: -0.500,0.500  
 Y: -1.243,1.257

Centroid:(0.000,0.000)  
 Moments of Inertia(in<sup>4</sup>): I<sub>x</sub>=0.486,I<sub>y</sub>=0.095  
 Section modulus in bending(in<sup>3</sup>): W<sub>x</sub>=0.387,W<sub>y</sub>=0.190  
 Radii of Gyration: X: 0.820, Y: 0.363

MATERIAL		SEE NOTES
Third Angle Projection:		
GENERAL SPECIFICATIONS		
All Dimensions in inches [millimeters]		
Tolerances		
X.XXX ± 0.01 [0.25mm]	Break all sharp edges	
X.XX ± 0.02 [0.50mm]	.010-.020 unless	
X.X ± 0.039 [1.0mm]	otherwise specified.	
DRAWN BY		DATE
zcg		02/21/2013
CHECKED BY		
APPROVALS		

<b>Sunmodo Corp.</b>	
1905 E 5TH STREET, SUITE A, VANCOUVER, WA 98661	
TITLE HELIO STANDARD RAIL	
DRAWING NUMBER	A20144
SCALE: NONE	SHEET 1 of 1

NOTES: UNLESS OTHERWISE SPECIFIED

1. DIMENSIONS SHOWN ARE INCHES [MILIMETERS].
2. MATERIAL: 6005-T5.  
FINISH: CLEAR ANODIZED 10um THICK.
3. THE UNSPECIFIED RADII ARE .02" MAX.
4. THE UNSPECIFIED DIMENSIONS ARE SPECIFIED BY 2D CAD FILE.

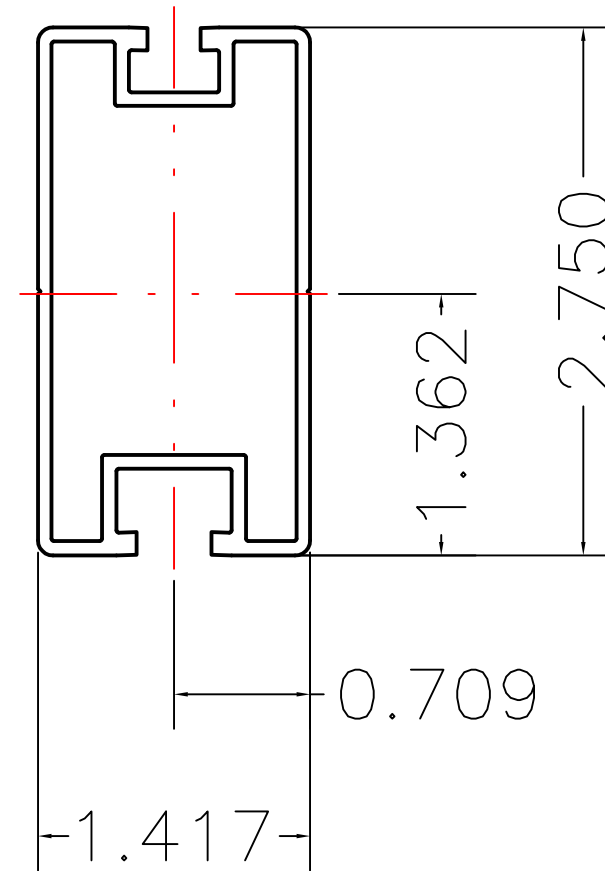

### Section properties:

Weight: 0.862 lbs/ft  
 Area: 0.736 in<sup>2</sup>  
 Perimeter: 19.824 in  
 Bounding Box: X: -0.709,0.709  
                   Y: -1.362,1.388  
 Centroid:(0.000,0.000)  
 Moments of Inertia(in<sup>4</sup>): I<sub>x</sub>=0.727,I<sub>y</sub>=0.214  
 Section modulus in bending(in<sup>3</sup>): W<sub>x</sub>=0.524,W<sub>y</sub>=0.302  
 Radii of Gyration: X: 0.994, Y: 0.539

THIS DRAWING IS CONFIDENTIAL PROPERTY OF SUNMODO AND ITS CONTENTS MAY NOT BE DISCLOSED WITHOUT THE PRIOR WRITTEN CONSENT OF SUNMODO CORP.

MATERIAL SEE NOTES		<b>SunModo Corp.</b> 14800 NE 65TH STREET, VANCOUVER WA 98682	
Third Angle Projection:			
GENERAL SPECIFICATIONS All Dimensions in inches [millimeters]		TITLE RAIL, HR300 (SUNRAY), EXTRUSION	
Tolerances X.XXX ±0.01 [0.25mm] X.XX ±0.02 [0.50mm] Break all sharp edges X.X ±0.039 [1.0mm] .010-.020 unless Unless otherwise spec'd otherwise specified.			
DRAWN BY KYY	DATE 01/18/2018	B	DRAWING NUMBER A20288
CHECKED BY			
APPROVALS		SCALE: NONE	SHEET 1 of 1

REV	DESCRIPTON	BY	DATE
A	0.44 WAS 0.41, 0.44 WAS 0.33	LWF	11/30/2015

NOTES: UNLESS OTHERWISE SPECIFIED

1. DIMENSIONS SHOWN ARE INCHES [MILIMETERS].
2. MATERAIL: ALUMINUM 6005-T5.  
FINISH: CLEAR ANODIZED 15  $\mu$ m THICK.
3. THE UNSPECIFIED DIMENSIONS ARE SPECIFIED BY 2D CAD FILE.

2X 1/4 BOLT SLOT

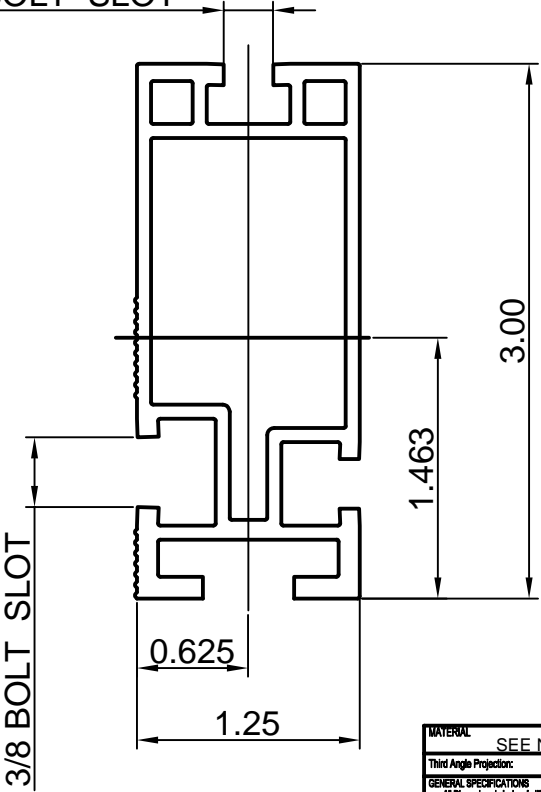

Section properties:

Weight: 1.151 lbs/ft  
 Area: 0.980 in<sup>2</sup>  
 Perimeter: 22.104 in  
 Bounding Box: X: -0.625,0.625  
                   Y: -1.463,1.537  
 Centroid:(0.000,0.000)  
 Moments of Inertia(in<sup>4</sup>): Ix=1.047,Iy=0.207  
 Section modulus in bending(in<sup>3</sup>): Wx=0.681,Wy=0.331  
 Radii of Gyration: X: 1.034, Y: 0.460

MATERIAL		SEE NOTES	
Third Angle Projection			
GENERAL SPECIFICATIONS			
All Dimensions in Inches [millimeters]			
Tolerances			
XXX ±0.01 (0.25mm)			
XX ±0.02 (0.50mm)			
X ±0.03 (1.0mm)			
Unless otherwise specified.			
Break all sharp edges 0.10-0.25 unless otherwise specified.			
DRAWN BY		DATE	
ZCJ		02/21/2013	
CHECKED BY		B	
APPROVALS		DRAWING NUMBER	
		A20145	
SCALE:		SHEET	
NONE		1 of 1	

Sunmodo Corp.

1905 E 5TH STREET, SUITE A, VANCOUVER, WA 98661

HELIO HEAVY RAIL

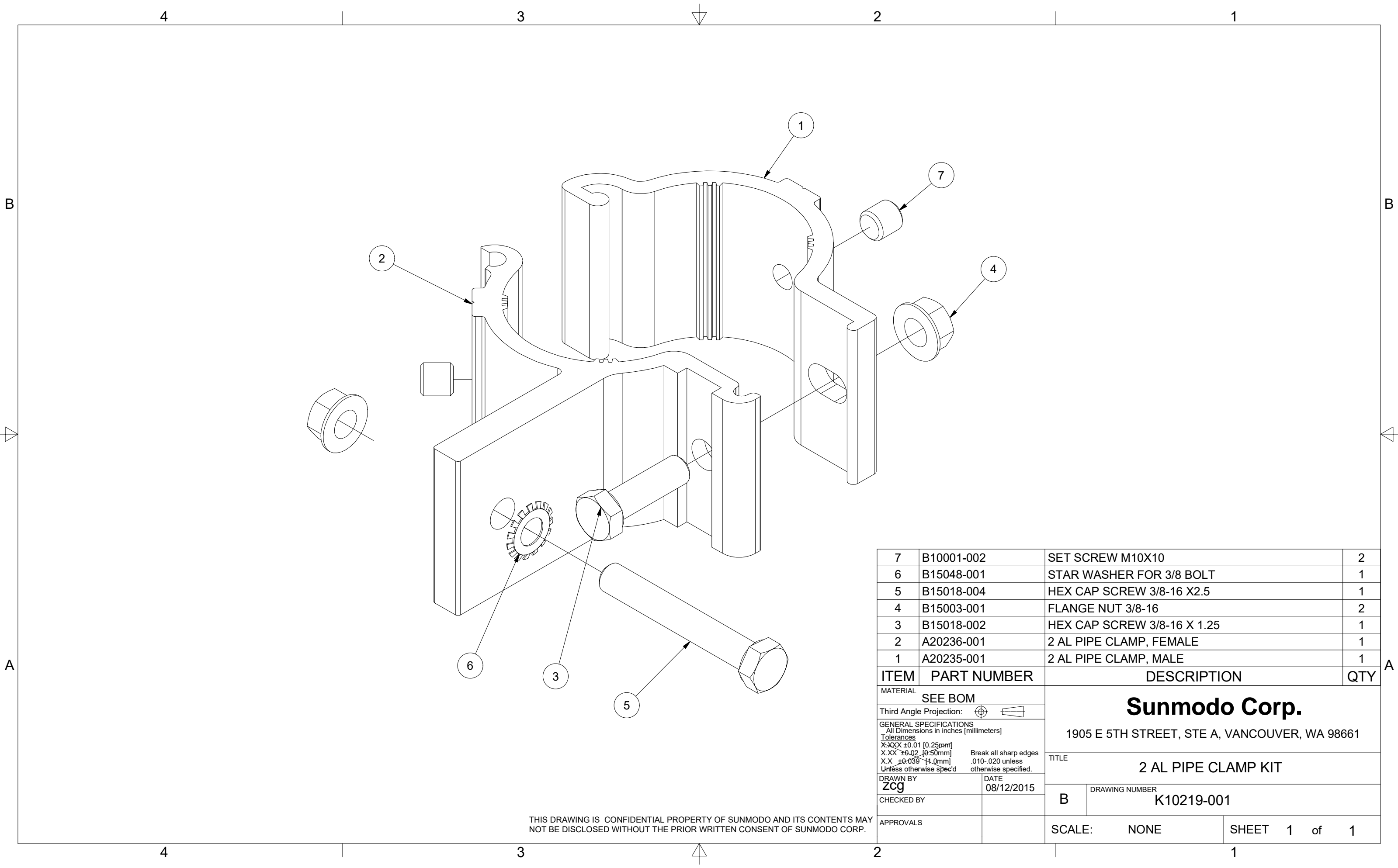

7	B10001-002	SET SCREW M10X10	2
6	B15048-001	STAR WASHER FOR 3/8 BOLT	1
5	B15018-004	HEX CAP SCREW 3/8-16 X2.5	1
4	B15003-001	FLANGE NUT 3/8-16	2
3	B15018-002	HEX CAP SCREW 3/8-16 X 1.25	1
2	A20236-001	2 AL PIPE CLAMP, FEMALE	1
1	A20235-001	2 AL PIPE CLAMP, MALE	1

ITEM	PART NUMBER	DESCRIPTION	QTY
MATERIAL		SEE BOM	
Third Angle Projection:			
GENERAL SPECIFICATIONS All Dimensions in inches (millimeters)			
Tolerances			
X.XXX ±0.01 [0.25mm]		Break all sharp edges	
X.XX ±0.02 [0.50mm]		.010-.020 unless	
X.X ±0.039 [1.0mm]		otherwise specified.	
DRAWN BY		DATE	
zcg		08/12/2015	
CHECKED BY		B	
APPROVALS		DRAWING NUMBER	
		K10219-001	
SCALE:		NONE	SHEET 1 of 1

**Sunmodo Corp.**  
1905 E 5TH STREET, STE A, VANCOUVER, WA 98661

THIS DRAWING IS CONFIDENTIAL PROPERTY OF SUNMODO AND ITS CONTENTS MAY NOT BE DISCLOSED WITHOUT THE PRIOR WRITTEN CONSENT OF SUNMODO CORP.

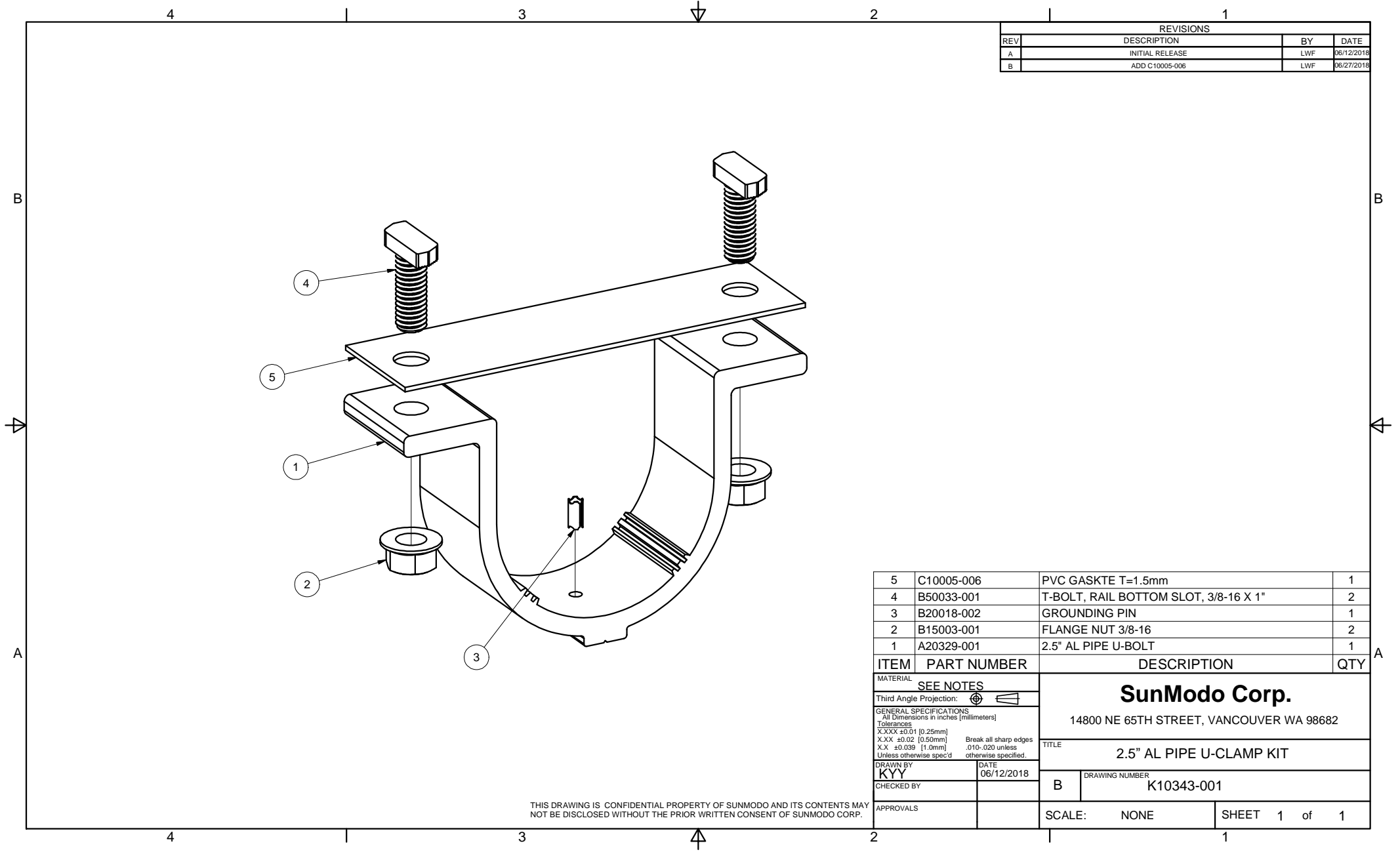

REVISIONS			
REV	DESCRIPTION	BY	DATE
A	INITIAL RELEASE	LWF	06/12/2018
B	ADD C10005-006	LWF	06/27/2018

ITEM	PART NUMBER	DESCRIPTION	QTY
5	C10005-006	PVC GASKTE T=1.5mm	1
4	B50033-001	T-BOLT, RAIL BOTTOM SLOT, 3/8-16 X 1"	2
3	B20018-002	GROUNDING PIN	1
2	B15003-001	FLANGE NUT 3/8-16	2
1	A20329-001	2.5" AL PIPE U-BOLT	1

MATERIAL		<b>SEE NOTES</b>	
Third Angle Projection:			
GENERAL SPECIFICATIONS		<p><b>SunModo Corp.</b> 14800 NE 65TH STREET, VANCOUVER WA 98682</p>	
<p>All Dimensions in inches [millimeters]</p> <p>Tolerances</p> <p>X.XXX ±0.01 [0.25mm]</p> <p>X.XX ±0.02 [0.50mm]</p> <p>X.X ±0.039 [1.0mm]</p> <p>Unless otherwise spec'd</p>			
TITLE		2.5" AL PIPE U-CLAMP KIT	
DRAWN BY	DATE	DRAWING NUMBER	
KYY	06/12/2018	B K10343-001	
CHECKED BY			
APPROVALS		SCALE: NONE	SHEET 1 of 1

THIS DRAWING IS CONFIDENTIAL PROPERTY OF SUNMODO AND ITS CONTENTS MAY NOT BE DISCLOSED WITHOUT THE PRIOR WRITTEN CONSENT OF SUNMODO CORP.

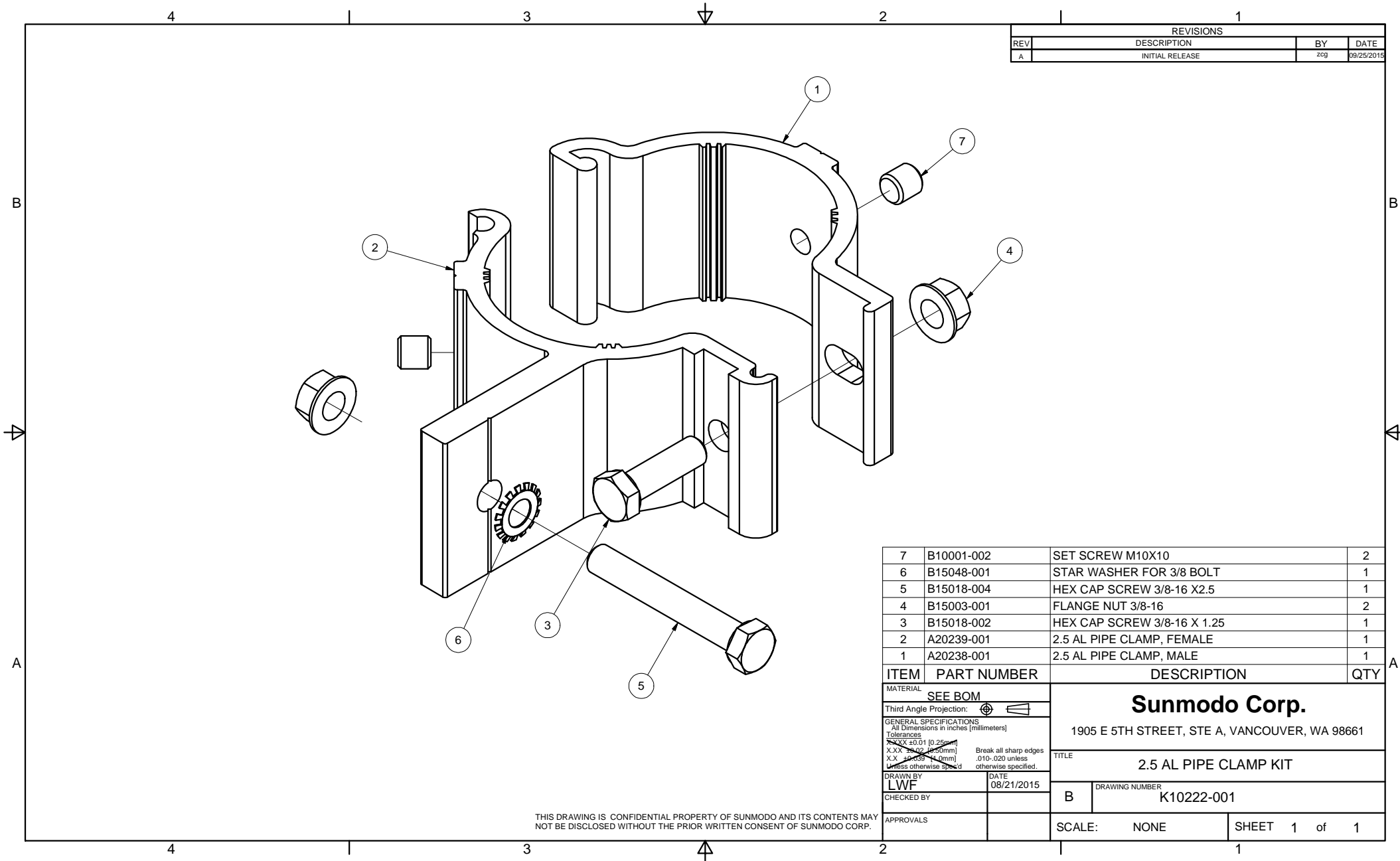

REVISIONS			
REV	DESCRIPTION	BY	DATE
A	INITIAL RELEASE	zcg	09/25/2015

ITEM	PART NUMBER	DESCRIPTION	QTY
7	B10001-002	SET SCREW M10X10	2
6	B15048-001	STAR WASHER FOR 3/8 BOLT	1
5	B15018-004	HEX CAP SCREW 3/8-16 X2.5	1
4	B15003-001	FLANGE NUT 3/8-16	2
3	B15018-002	HEX CAP SCREW 3/8-16 X 1.25	1
2	A20239-001	2.5 AL PIPE CLAMP, FEMALE	1
1	A20238-001	2.5 AL PIPE CLAMP, MALE	1

MATERIAL		<b>SEE BOM</b>	
Third Angle Projection:			
<b>GENERAL SPECIFICATIONS</b> All Dimensions in inches [millimeters] <b>Tolerances</b> X.XX ±0.01 [0.25mm] X.X ±0.02 [0.5mm] X.X ±0.03 [0.75mm] Unless otherwise specified.			
DRAWN BY		DATE	
LWF		08/21/2015	
CHECKED BY		B	
APPROVALS		SCALE: NONE	
		SHEET 1 of 1	

**Sunmodo Corp.**  
 1905 E 5TH STREET, STE A, VANCOUVER, WA 98661

TITLE: **2.5 AL PIPE CLAMP KIT**

DRAWING NUMBER: **K10222-001**

THIS DRAWING IS CONFIDENTIAL PROPERTY OF SUNMODO AND ITS CONTENTS MAY NOT BE DISCLOSED WITHOUT THE PRIOR WRITTEN CONSENT OF SUNMODO CORP.

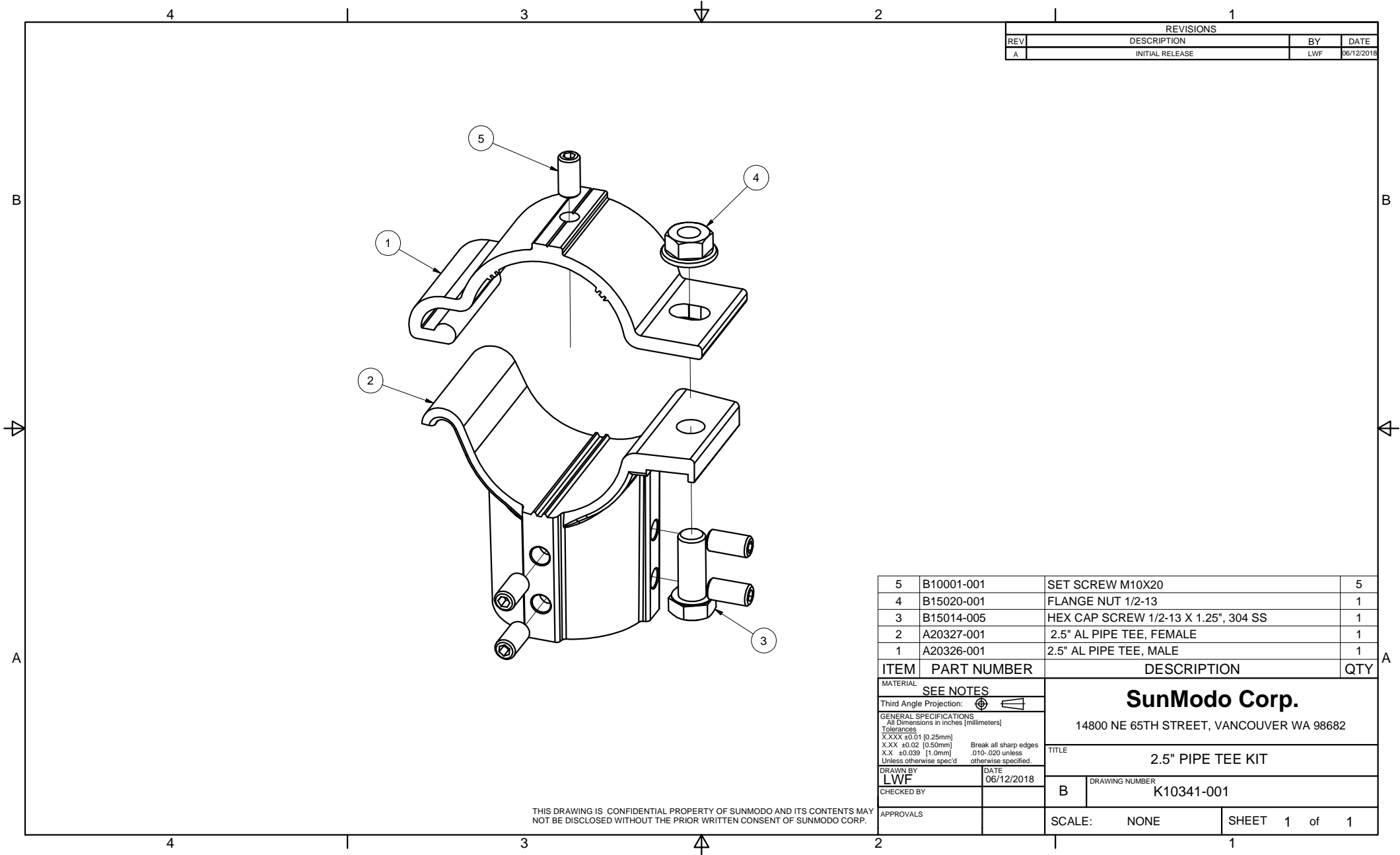

REVISIONS			
REV	DESCRIPTION	BY	DATE
A	INITIAL RELEASE	LWF	06/12/2018

ITEM	PART NUMBER	DESCRIPTION	QTY
5	B10001-001	SET SCREW M10X20	5
4	B15020-001	FLANGE NUT 1/2-13	1
3	B15014-005	HEX CAP SCREW 1/2-13 X 1.25", 304 SS	1
2	A20327-001	2.5" AL PIPE TEE, FEMALE	1
1	A20326-001	2.5" AL PIPE TEE, MALE	1

MATERIAL		SEE NOTES	
Third Angle Projection:			
GENERAL SPECIFICATIONS		<b>SunModo Corp.</b> 14800 NE 65TH STREET, VANCOUVER WA 98682	
Tolerances		TITLE	
X.XXX ±0.01 [0.25mm] X.XX ±0.02 [0.50mm] X.X ±0.039 [1.0mm] Unless otherwise spec'd		2.5" PIPE TEE KIT	
DRAWN BY		DATE	
LWF		06/12/2018	
CHECKED BY		DRAWING NUMBER	
		B K10341-001	
APPROVALS		SCALE: NONE SHEET 1 of 1	

THIS DRAWING IS CONFIDENTIAL PROPERTY OF SUNMODO AND ITS CONTENTS MAY NOT BE DISCLOSED WITHOUT THE PRIOR WRITTEN CONSENT OF SUNMODO CORP.

REVISIONS			
REV	DESCRIPTION	BY	DATE
A	INITIAL RELEASE	LWF	06/12/2018

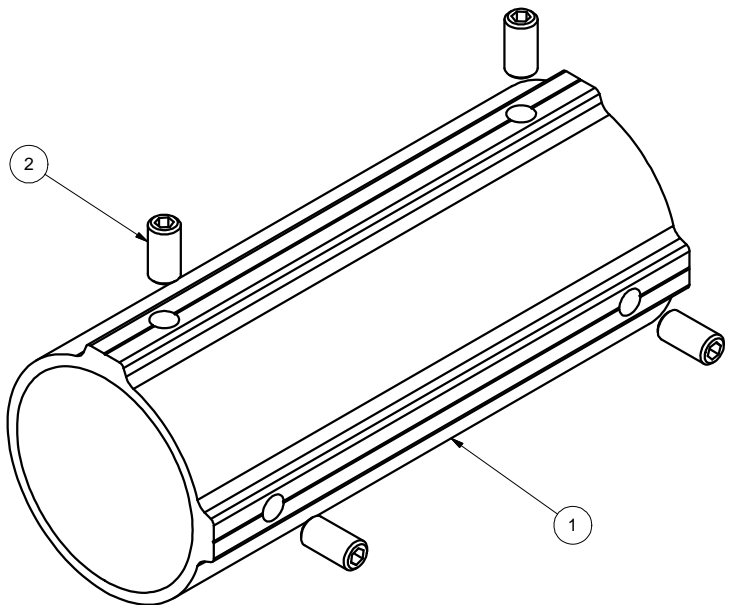

2	B10001-001	SET SCREW M10X20	4
1	A20328-001	2.5" PIPE SPLICE	1
ITEM	PART NUMBER	DESCRIPTION	QTY
MATERIAL		SEE NOTES	
Third Angle Projection:			
GENERAL SPECIFICATIONS		<b>SunModo Corp.</b> 14800 NE 65TH STREET, VANCOUVER WA 98682	
All Dimensions in inches [millimeters] Tolerances X.XXX ±0.01 [0.25mm] X.XX ±0.02 [0.50mm] X.X ±0.039 [1.0mm] Unless otherwise spec'd		Break all sharp edges .010-.020 unless otherwise specified.	
DRAWN BY		TITLE	
LWF		2.5" PIPE SPLICE KIT	
DATE		DRAWING NUMBER	
06/12/2018		B K10342-001	
CHECKED BY		SCALE: NONE	
APPROVALS		SHEET 1 of 1	

THIS DRAWING IS CONFIDENTIAL PROPERTY OF SUNMODO AND ITS CONTENTS MAY NOT BE DISCLOSED WITHOUT THE PRIOR WRITTEN CONSENT OF SUNMODO CORP.

NOTES: UNLESS OTHERWISE SPECIFIED

1. DIMENSIONS SHOWN ARE INCHES [MILIMETERS].
2. MATERIAL:HIGH STRENGTH STEEL PIPE OR TUBE.
3. FINISH: HOT DIP GALVANIZE PER ASTM A123 / A123M - 02.

MINIMUM 50 KSI YIELD STRESS.

4. BREAK ALL BURRS AND SHARP EDGES.

5. ALL WELDING MUST BE IN COMPLIANCE WITH AWS CODE D1;1.

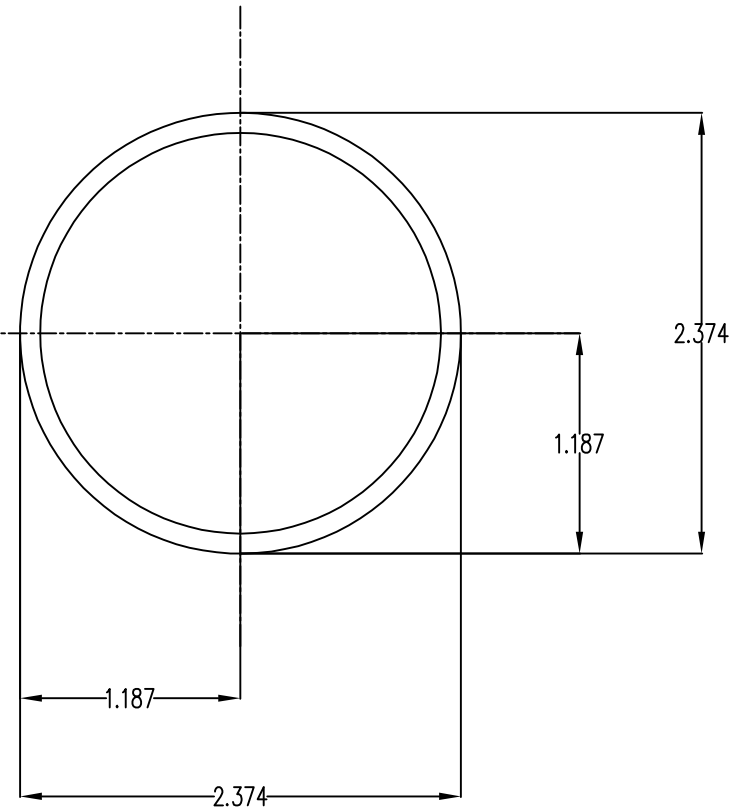

## Section properties:

Weight: 2.641 lbs/ft

Area: 0.776 in<sup>2</sup>

Perimeter: 14.238 in

Bounding Box: X: -1.187,1.187

Y: -1.187,1.187

Centroid:(0.000,0.000)

Moments of Inertia(in<sup>4</sup>): Ix=0.499,Iy=0.499

Section modulus in bending(in<sup>3</sup>): Wx=0.420,Wy=0.420

Radii of Gyration: X: 0.802, Y: 0.802

MATERIAL		SEE NOTES		<b>Sunmodo Corp.</b> 14800 NE 85TH STREET, VANCOUVER WA 98682	
Third Angle Projection:					
GENERAL SPECIFICATIONS				TITLE	
All Dimensions in Inches (millimeters)				PIPE, HSS, 2.375" OD X 12 GAUGE,L=XXX	
Tolerances				Break all sharp edges .010-.020 unless otherwise specified.	
XXX ±0.01 (0.25mm)					
XX ±0.02 (0.50mm)					
X ±0.050 (1.2mm)					
Unless otherwise specified					
DRAWN BY	DATE	B		DRAWING NUMBER	
LWF	04/03/2019			A21165	
CHECKED BY					
APPROVALS				SCALE: NONE SHEET 1 of 1	

NOTES: UNLESS OTHERWISE SPECIFIED

1. DIMENSIONS SHOWN ARE INCHES [MILIMETERS].
2. MATERAIL:HIGH STRENGTH STEEL PIPE OR TUBE.
3. FINISH: HOT DIP GALVANIZE PER ASTM A123 / A123M - 02.

MINIMUM 50 KSI YIELD STRESS.

4. BREAK ALL BURRS AND SHARP EDGES.
5. ALL WELDING MUST BE IN COMPLIANCE WITH AWS CODE D1;1.

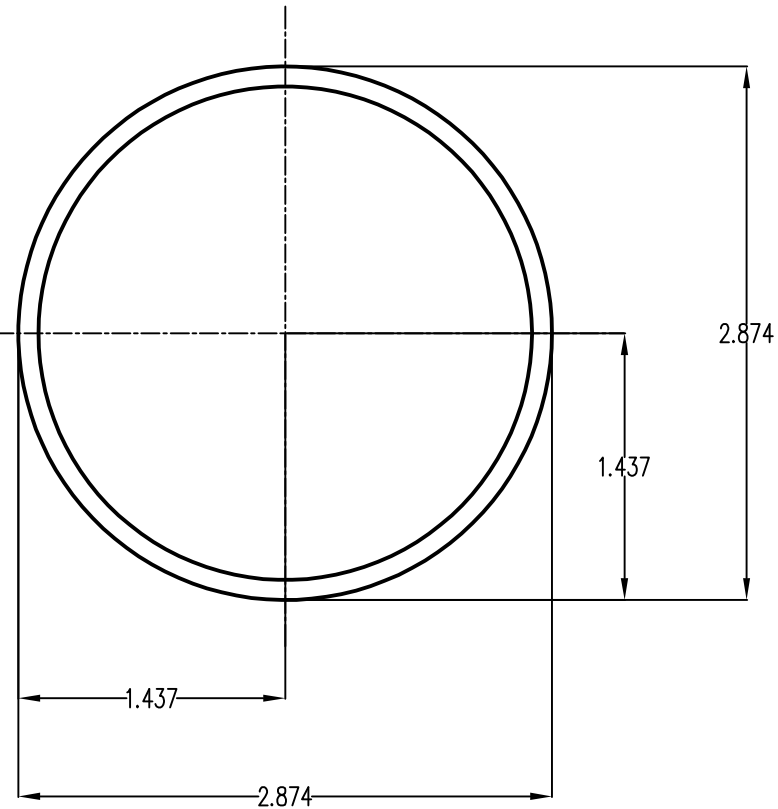

### Section properties:

Weight: 3.201 lbs/ft

Area: 0.941 in<sup>2</sup>

Perimeter: 17.378 in

Bounding Box: X: -1.437,1.437

Y: -1.437,1.437

Centroid:(0.000,0.000)

Moments of Inertia(in<sup>4</sup>): Ix=0.901,Iy=0.901

Section modulus in bending(in<sup>3</sup>): Wx=0.627,Wy=0.627

Radii of Gyration: X: 0.979, Y: 0.979

MATERIAL		SEE NOTES		<b>Sunmodo Corp.</b>	
Third Angle Projection:					
GENERAL SPECIFICATIONS				TITLE	
All Dimensions in Inches (millimeters)				PIPE, HSS, 2.875" OD X 12 GAUGE,L=XXX	
Tolerances				DRAWING NUMBER	
XXX ±0.01 (0.25mm)				A21168	
XX ±0.02 (0.50mm)				SCALE: NONE	
X ±0.030 (0.75mm)				SHEET 1 of 1	
Unless otherwise specified				DATE	
DRAWN BY		DATE		APPROVALS	
LWF		04/03/2019			
CHECKED BY					