

SUNMODO CORPORATION TEST REPORT

SCOPE OF WORK

ASTM E331 AND ASTM E2140 TESTING ON NANOMOUNT®, ROOF ATTACHMENTS

REPORT NUMBER

N0901.01-109-44

TEST DATE(S)

02/24/22

ISSUE DATE

03/02/22

RECORD RETENTION END DATE

02/24/26

PAGES

14

DOCUMENT CONTROL NUMBER

RT-R-AMER-Test-2805 (10/11/21)

© 2017 INTERTEK

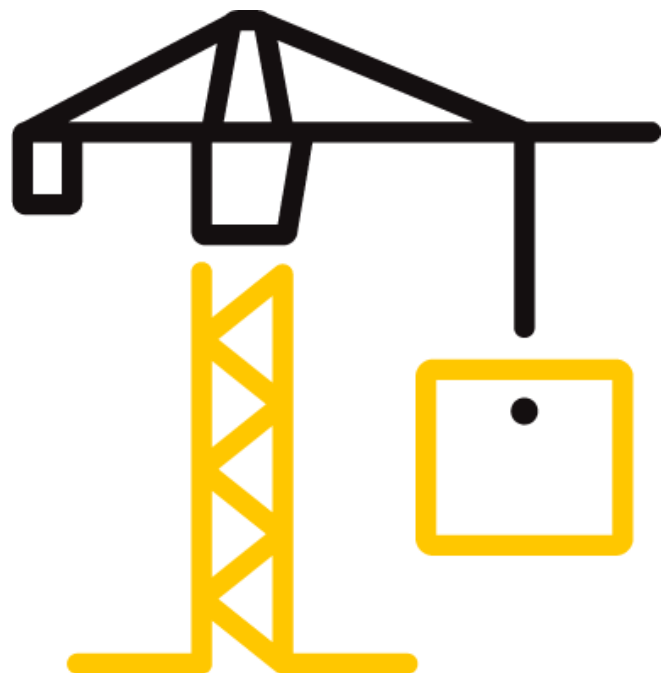

TEST REPORT FOR SUNMODO CORPORATION

Report No.: N0901.01-109-44

Date: 03/02/22

REPORT ISSUED TO

SUNMODO CORPORATION

14800 NE 65th Street
Vancouver, Washington 98682

SECTION 1

SCOPE

Architectural Testing, Inc. (an Intertek company) dba Intertek Building & Construction (B&C) was contracted by SunModo Corporation to perform testing in accordance with ASTM E331 and ASTM E2140 on their NanoMount®, roof attachments. Results obtained are tested values and were secured by using the designated test method(s). Testing was conducted at Intertek B&C test facility in York, Pennsylvania.

SECTION 2

SUMMARY OF TEST RESULTS

TITLE	RESULTS
Static Water Test at 720 Pa (15.04 psf)	No water penetration observed
Static Water Pressure Head at 6" (152 mm)	No water penetration observed

For INTERTEK B&C:

COMPLETED BY:	Richard E. Hartman III	REVIEWED BY:	Ken R. Stough
TITLE:	Technician – Product Testing	TITLE:	Project Manager – Product Testing
SIGNATURE:		SIGNATURE:	
DATE:	03/02/22	DATE:	03/02/22

REH:nls

This report is for the exclusive use of Intertek's Client and is provided pursuant to the agreement between Intertek and its Client. Intertek's responsibility and liability are limited to the terms and conditions of the agreement. Intertek assumes no liability to any party, other than to the Client in accordance with the agreement, for any loss, expense or damage occasioned by the use of this report. Only the Client is authorized to permit copying or distribution of this report and then only in its entirety. Any use of the Intertek name or one of its marks for the sale or advertisement of the tested material, product or service must first be approved in writing by Intertek. The observations and test results in this report are relevant only to the sample(s) tested. This report by itself does not imply that the material, product, or service is or has ever been under an Intertek certification program.

TEST REPORT FOR SUNMODO CORPORATION

Report No.: N0901.01-109-44

Date: 03/02/22

SECTION 3

TEST METHOD(S)

The specimens were evaluated in accordance with the following:

ASTM E331-00(2016), *Standard Test Method for Water Penetration of Exterior Windows, Skylights, Doors, and Curtain Walls by Uniform Static Air Pressure Difference*

ASTM E2140-01(2017), *Standard Test Method for Water Penetration of Metal Roof Panel Systems by Static Water Pressure Head*

SECTION 4

MATERIAL SOURCE/INSTALLATION

Test specimen(s) were provided by the client. Representative samples of the test specimen(s) will be retained by Intertek B&C for a minimum of four years from the test completion date.

Installation of the tested product was performed by the Intertek B&C. The test specimens were tested at a 2° slope.

SECTION 5

EQUIPMENT

Tape Measure Verification: 63788

Weather Station: INT00382

Skylight Spray Rack and Pressure Gauge: INT01386

Control Panel: 005644

SECTION 6

LIST OF OFFICIAL OBSERVERS

NAME	COMPANY
Ken R. Stough	Intertek B&C
Richard E. Hartman III	Intertek B&C

TEST REPORT FOR SUNMODO CORPORATION

Report No.: N0901.01-109-44

Date: 03/02/22

SECTION 7

TEST SPECIMEN DESCRIPTION

Product Type: Roof Attachment

Series/Model: NanoMount®

Test Deck Description:

The test deck measured 48" by 48" and was constructed from Spruce-Pine-Fir 2x8 lumber with two 2x4 joists spaced 24" on center. The test deck was sheathed with 15/32" plywood secured using #8 x 1-5/8" flat head screws spaced 12" on center. A layer of TPO was placed over the sheathing and sealed to the exterior perimeter of the deck with duct tape.

Nano Mount Description:

The test specimens consisted of a 4" diameter by 3-7/16" high by 5/16" thick aluminum mount. One 11/32" diameter installation hole was placed at the center of the base and four 1/4" diameter installation holes were evenly spaced on the base. A 3-1/2" diameter by 1/4" thick self-stick foam pad was adhered to the underside of the base. All test specimens utilized GE All Purpose 100% silicone sealant

Nano Rafter Mount Installation:

A 7/32" pilot hole was drilled at all mounting locations. Test Specimens #1 and #2 did not utilize sealant applied to the foam pad. Test Specimens #3 and #4 utilized a circular bead of sealant applied to the foam pad on the underside of the base (Reference Section 11, Rafter Mount Installation). The mounts were then placed over the pre-drilled holes and secured with one 5/16" x 4-1/4" hex socket head lag screw with a 3/4" diameter washer with EPDM seal through the mount and into the joist (Reference Section 11, Rafter Mount Installation). Sealant was then utilized at the fastener and the perimeter of each test specimen (Reference Section 11, Rafter Mount Installation).

Nano Deck Mount Installation:

Test Specimens #5 and #6 did not utilize sealant applied to the foam pad. Test Specimens #7 and #8 utilized a circular bead of sealant applied to the foam pad on the underside of the base (Reference Section 11, Deck Mount Installation). The mounts were then placed over the deck and secured with four 1/4" x 3" hex head screws with 5/8" diameter washer with EPDM seal through the mount and into the sheathing (Reference Section 11, Deck Mount Installation). Sealant was then utilized at the fastener and the perimeter of each test specimen (Reference Section 11, Deck Mount Installation).

TEST REPORT FOR SUNMODO CORPORATION

Report No.: N0901.01-109-44

Date: 03/02/22

SECTION 8

TEST RESULTS

The temperature during testing was 19°C (67°F). The results are tabulated as follows:

Test Specimens #1 - #8:

TITLE OF TEST	RESULTS	ALLOWED	NOTE
Water Penetration, ASTM E331 at 720 Pa (15.04 psf)	Pass	No leakage	1
Water Penetration, ASTM E2140 at 6" (152mm) Static Water Pressure Head	Pass	No leakage	2, 3

General Note: All testing was performed in accordance with the referenced standard(s).

Note 1: ASTM E331 static water pressure was maintained for fifteen minutes.

Note 2: ASTM E2140 static water pressure head was maintained for six hours

Note 3: The specimen was observed for water leakage after one hour, three hours, and immediately prior to termination of test.

SECTION 9

CONCLUSION

This report does not constitute certification of this product nor an opinion or endorsement by this laboratory. Intertek B&C will service this report for the entire test record retention period. The test record retention period ends four years after the test date. Test records, such as detailed drawings, datasheets, representative samples of test specimens, or other pertinent project documentation, will be retained for the entire test record retention period.

Unless differently required, Intertek reports apply the "Simple Acceptance" rule, also called "Shared Risk approach," of ILAC-G8:09/2019, Guidelines on Decision Rules and Statements of Conformity.

TEST REPORT FOR SUNMODO CORPORATION

Report No.: N0901.01-109-44

Date: 03/02/22

SECTION 10

PHOTOGRAPHS

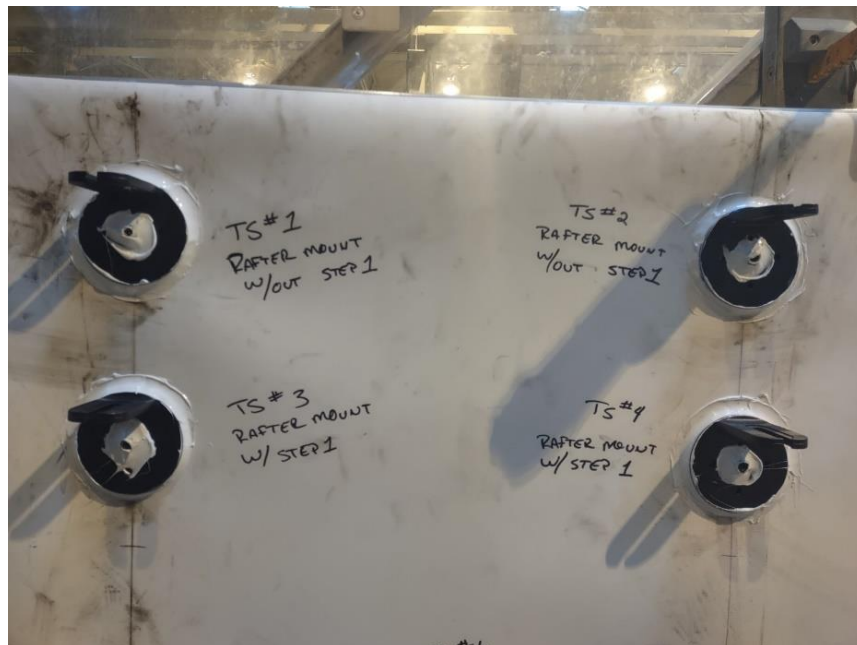

Photo No. 1
View of Test Specimens #1 - #4, Nano Rafter Mount

TEST REPORT FOR SUNMODO CORPORATION

Report No.: N0901.01-109-44

Date: 03/02/22



Photo No. 2
View of Test Specimens #5 - #8, Nano Deck Mount

TEST REPORT FOR SUNMODO CORPORATION

Report No.: N0901.01-109-44

Date: 03/02/22

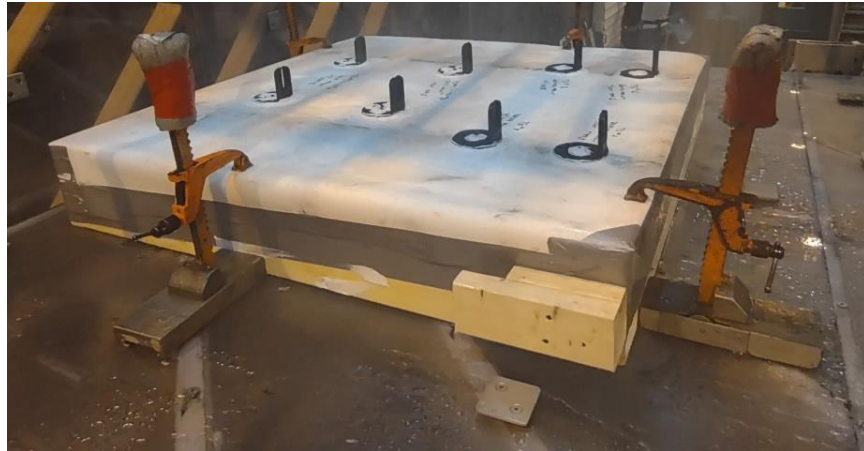

Photo No. 3

View of Test Deck During ASTM E331 Testing at 2° Slope



Photo No. 4

View of Test Deck Prior to ASTM E2104 Testing



Total Quality. Assured.

130 Derry Court
York, Pennsylvania 17406

Telephone: 717-764-7700
Facsimile: 717-764-4129
www.intertek.com/building

TEST REPORT FOR SUNMODO CORPORATION

Report No.: N0901.01-109-44

Date: 03/02/22

SECTION 11 DRAWINGS

The test specimen drawings have been reviewed by Intertek B&C and are representative of the test specimen(s) reported herein. Test specimen construction was verified by Intertek B&C per the drawings included in this report. Any deviations are documented herein or on the drawings.



Report #: N0901.01
 Date: 2/25/22
 Verified by: *Richard E. H. [Signature]*

REVISIONS			
REV	DESCRIPTION	BY	DATE
A	INITIAL RELEASED	LWF	08/05/2020

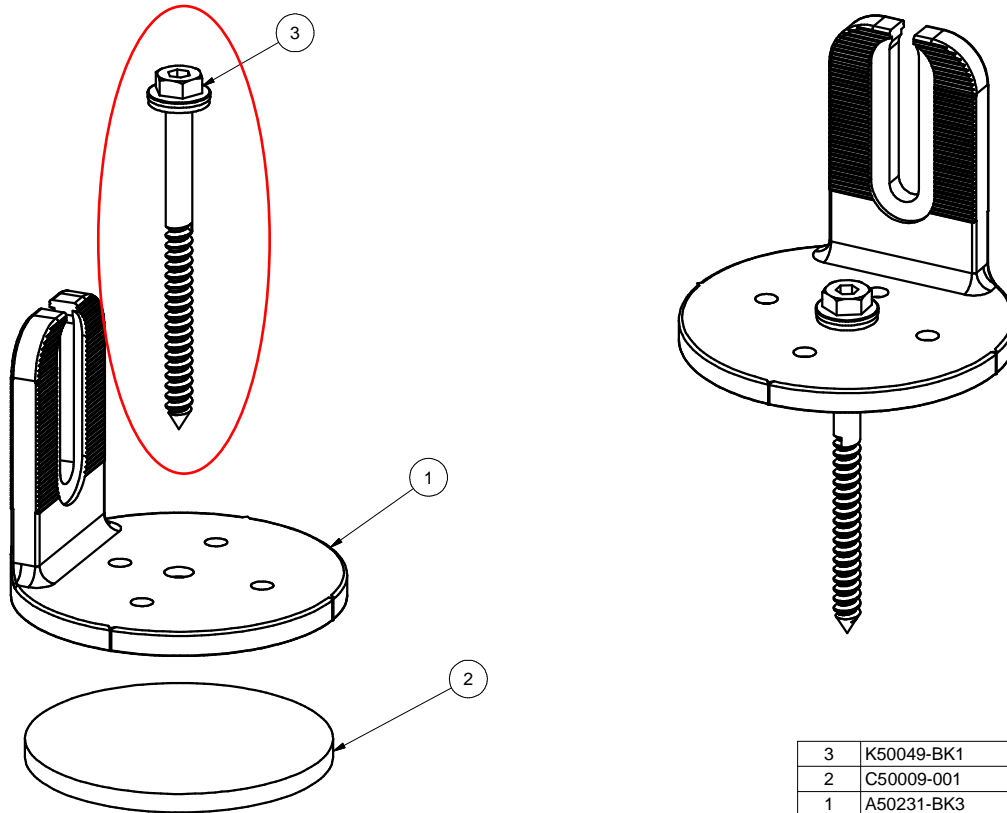

ITEM	PART NUMBER	DESCRIPTION	QTY
3	K50049-BK1	BLACK LAG BOLT WITH SEALING WASHER KIT	1
2	C50009-001	NANO GASKET, NEOPRENE FOAM	1
1	A50231-BK3	BLACK NANO MOUNT OPEN L-FOOT	1

MATERIAL		SEE NOTES	
Third Angle Projection:			
GENERAL SPECIFICATIONS All Dimensions in inches [millimeters] Tolerances X.XXX ±0.01 [0.25mm] X.XX ±0.02 [0.50mm] X.X ±0.039 [1.0mm] Unless otherwise spec'd			
DRAWN BY		DATE	
LWF		08/05/2020	
CHECKED BY		B	
APPROVALS		SCALE:	
		SHEET 1 of 1	

SunModo Corp.
 14800 NE 65TH STREET, VANCOUVER WA 98682
TITLE
 BLACK NANO RAFTER MOUNT COMBO KIT WITH LAG SCREW
DRAWING NUMBER
 K50053-BK1

THIS DRAWING IS CONFIDENTIAL PROPERTY OF SUNMODO AND ITS CONTENTS MAY NOT BE DISCLOSED WITHOUT THE PRIOR WRITTEN CONSENT OF SUNMODO CORP.



Report #: N0901.01
 Date: 2/25/22
 Verified by: *Richard E. H. [Signature]*

REVISIONS			
REV	DESCRIPTION	BY	DATE
A	INITIAL RELEASED	LWF	08/05/2020
B	UPDATE NUMBER	LWF	08/06/2020

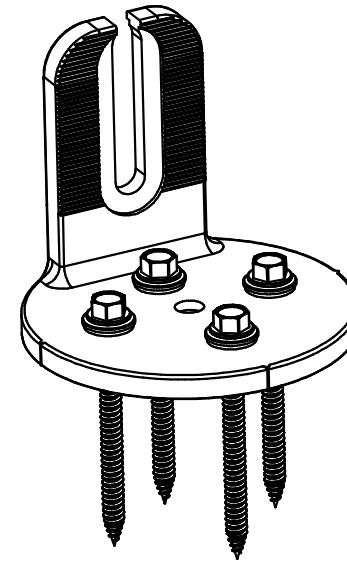
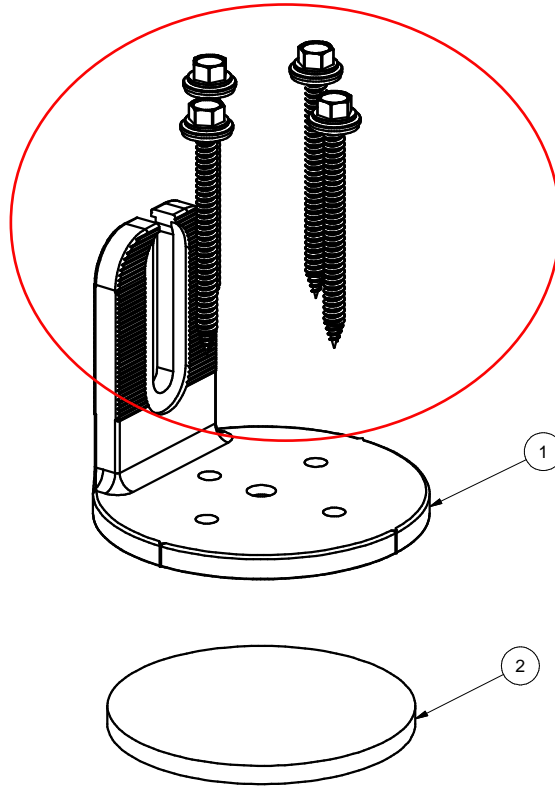

3	K50055-BK1	BLACK SELF-TAPPING SCREW WITH SEALING WASHER KIT	4
2	C50009-001	NANO GASKET, NEOPRENE FOAM	1
1	A50231-BK3	BLACK NANO MOUNT OPEN L-FOOT	1
ITEM	PART NUMBER	DESCRIPTION	QTY
MATERIAL		SEE NOTES	
Third Angle Projection:			
GENERAL SPECIFICATIONS		SunModo Corp. 14800 NE 65TH STREET, VANCOUVER WA 98682	
All Dimensions in inches [millimeters] Tolerances X.XXX ±0.01 [0.25mm] X.XX ±0.02 [0.50mm] X.X ±0.039 [1.0mm] Unless otherwise spec'd		TITLE BLACK NANO DECK MOUNT COMBO KIT WITH SELF-TAPPING SCREW	
DRAWN BY	DATE	DRAWING NUMBER	
LWF	08/05/2020	B K50053-BK3	
CHECKED BY		SCALE:	
APPROVALS		SHEET 1 of 1	

THIS DRAWING IS CONFIDENTIAL PROPERTY OF SUNMODO AND ITS CONTENTS MAY NOT BE DISCLOSED WITHOUT THE PRIOR WRITTEN CONSENT OF SUNMODO CORP.

Nano Rafter Mount Flat Roof Installation:

These installation instructions are of a general nature for attaching the NanoMount into a commercial or flat roofs. A flat roof is a roofing system that is nearly level with a slight slope.

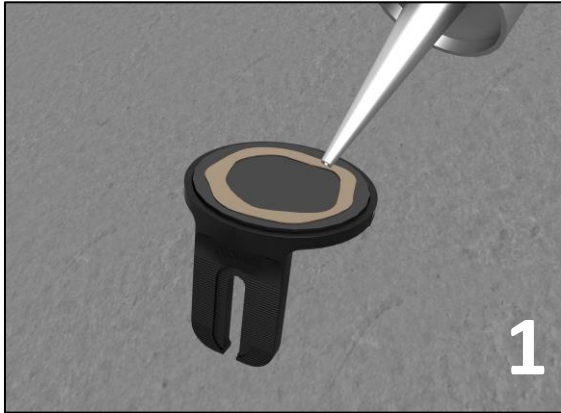

Clear the roof area of any dirt, grease or moisture before installing the NanoMount.

Apply a circular bead of composite roof sealant, such as Chem-link M1, around the bottom of the NanoMount.

Apply additional sealant to the roof if needed to seal gaps or to smooth uneven surfaces.

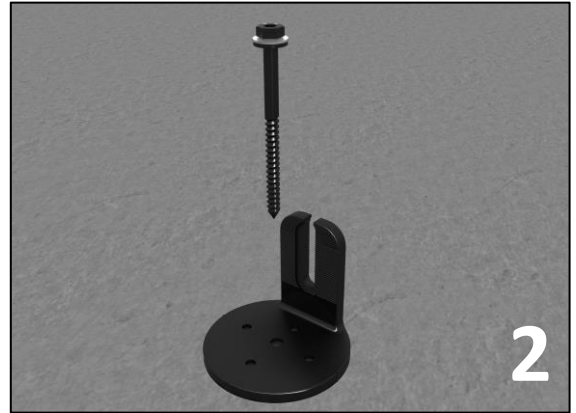

Locate the center of the rafter in the desired roof location and drill a 7/32" [6mm] pilot hole. Clear away any debris before filling the pilot hole with sealant.

Use either a 6mm Hex Bit or a 1/2" Hex Socket to install the 5/16" [M8] Lag Screw.

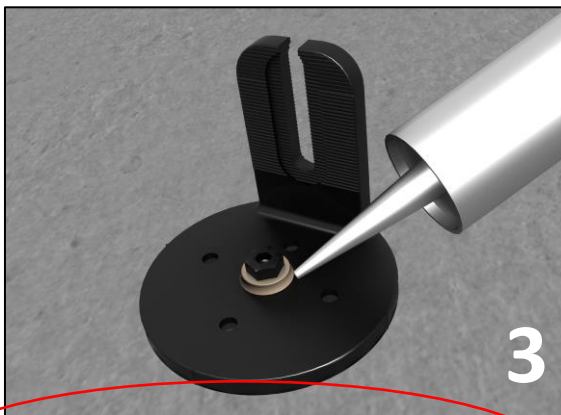

Apply a copious amount of sealant around the Lag Screw and Sealing Washer of the NanoMount.

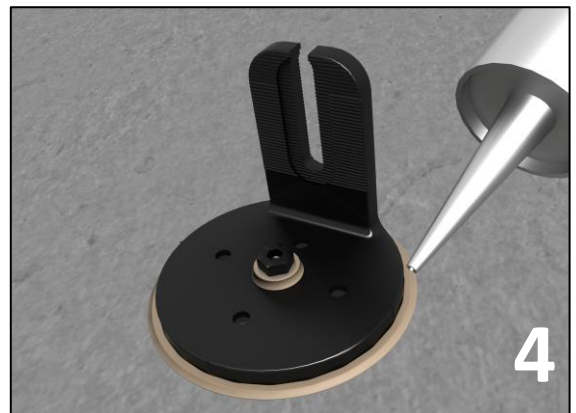

Apply a copious amount of sealant around the base of the NanoMount.

Nano Deck Mount Flat Roof Installation:

These installation instructions are of a general nature for attaching the NanoMount into a commercial or flat roofs. A flat roof is a roofing system that is nearly level with a slight slope.

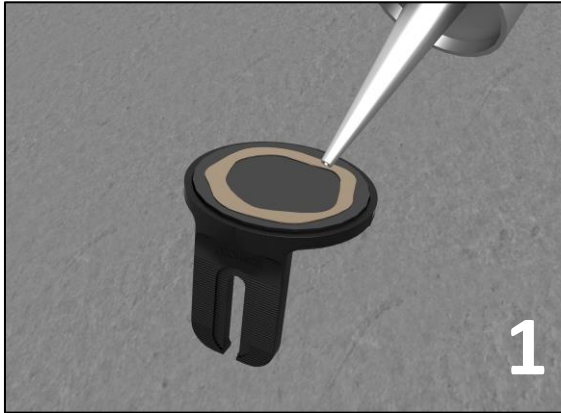

Clear the roof area of any dirt, grease or moisture before installing the NanoMount.

Apply a circular bead of composite roof sealant, such as Chem-link M1, around the bottom of the NanoMount.

Apply additional sealant to the roof if needed to seal gaps or to smooth uneven surfaces.

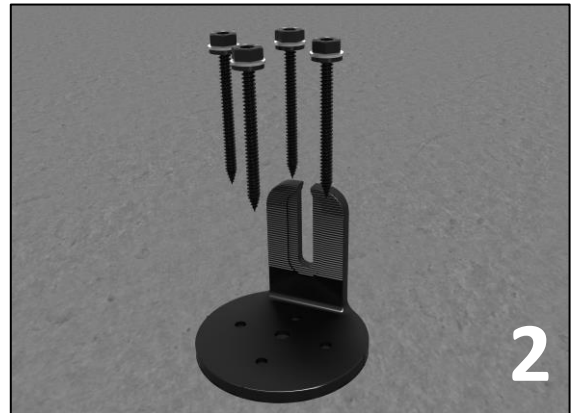

Locate the desired roof location and install the four (4) Self-Tapping Screws with Sealing Washers. Use a 3/8" Hex Socket.

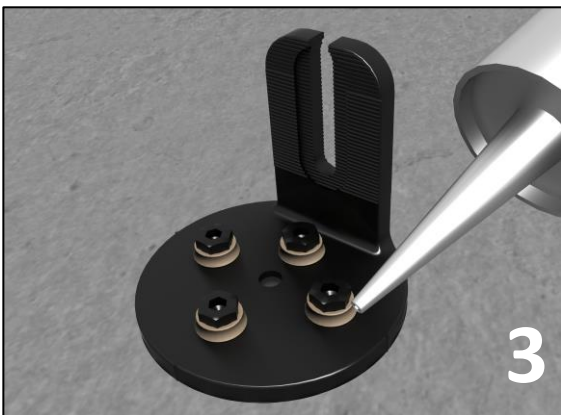

Apply a copious amount of sealant around the four (4) Self-Tapping Screws and Sealing Washers of the NanoMount.

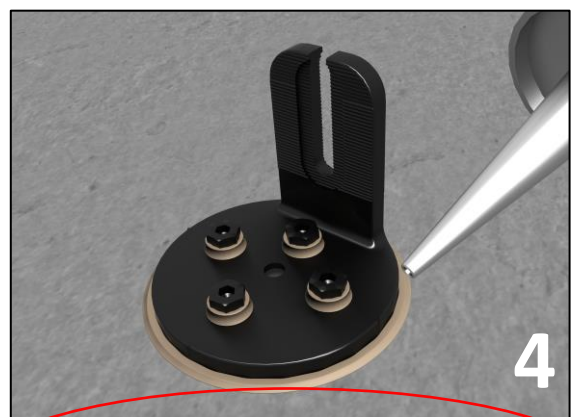

Apply a copious amount of sealant around the base of the NanoMount.



Report #:	N0901.01
Date:	2/25/22
Verified by:	<i>Richard E. H. [Signature]</i>



Total Quality. Assured.

130 Derry Court
York, Pennsylvania 17406

Telephone: 717-764-7700
Facsimile: 717-764-4129
www.intertek.com/building

TEST REPORT FOR SUNMODO CORPORATION

Report No.: N0901.01-109-44

Date: 03/02/22

SECTION 12

REVISION LOG

REVISION #	DATE	PAGES	REVISION
0	03/02/22	N/A	Original Report Issue