



Project Number: U2716-0319-211

August 16, 2021

Sunmodo
14800 NE 65th Street
Vancouver, WA 98682

**REFERENCE: Sunmodo Sunturf Ground Mount B6
Ground Mount PV Array Installation**

To Whom It May Concern:

Per request of Sunmodo, we have been asked to prepare the structural design of a ground-mounted PV solar array system with several foundation options as shown in the attached calculations. Vector Structural Engineering requires that we review each site specific install, and we are not liable for installs at site specific locations we have not reviewed. The following design parameters are used in our analysis:

- Code: International Building Code, 2015 Edition
- Minimum Design Loads for Buildings and Other Structures (ASCE 7-10)
- Design wind speed for risk category I structures: 105 mph
- Wind exposure: C
- Ground snow load: 30 psf
- The ground screws and helical piers must be tested to 1.5 times uplift and 2.0 times lateral reactions found in the table below. A minimum of one ground screw or helical pier must be tested.

Load (ASD)	Value (lbs)	Factor of Safety	Test Value (lbs)
UPLIFT	1681	1.5	2522
LATERAL	1153	2	2306

Foundation concrete shall have a minimum compressive strength of 2500 psi at 28 days. Cement for all concrete shall be Type I or II with a minimum of 6% entrained air with a water/cement ratio of 0.50. Maximum aggregate size shall be 3/4". No special inspection of concrete strength is required.

Footings are designed based on an allowable soil bearing pressure of 1500 psf an allowable skin friction of 250 psf, an allowable lateral bearing pressure of 150 pcf, and a coefficient of friction of 0.3. Vector Structural Engineering strongly recommends independent soils testing be performed by a licensed geotechnical engineer to verify the assumed soil parameters.

All ground mounts are to be installed per manufacturer’s recommendations. The use of solar panel support span tables provided by the manufacturer is allowed only where the site conditions and solar panel configuration match the description of the span tables. Electrical engineering is beyond our scope. All work performed must be in accordance with accepted industry-wide methods and applicable safety standards. Vector Structural Engineering assumes no responsibility for improper installation of the solar panels.

Very truly yours,

VECTOR STRUCTURAL ENGINEERING, LLC

Russell Emery, P.E.
Project Engineer

Enclosures

RNE/stb





JOB NO. U2716-0319-211
 PROJECT SUNMODO SUNTURF GROUND MOUNTS B6
 SUBJECT ALL OPTIONS

651 W GALENA PARK BLVD. #101 (801) 990-1775
 DRAPER, UTAH 84020 (801) 990-1776 FAX

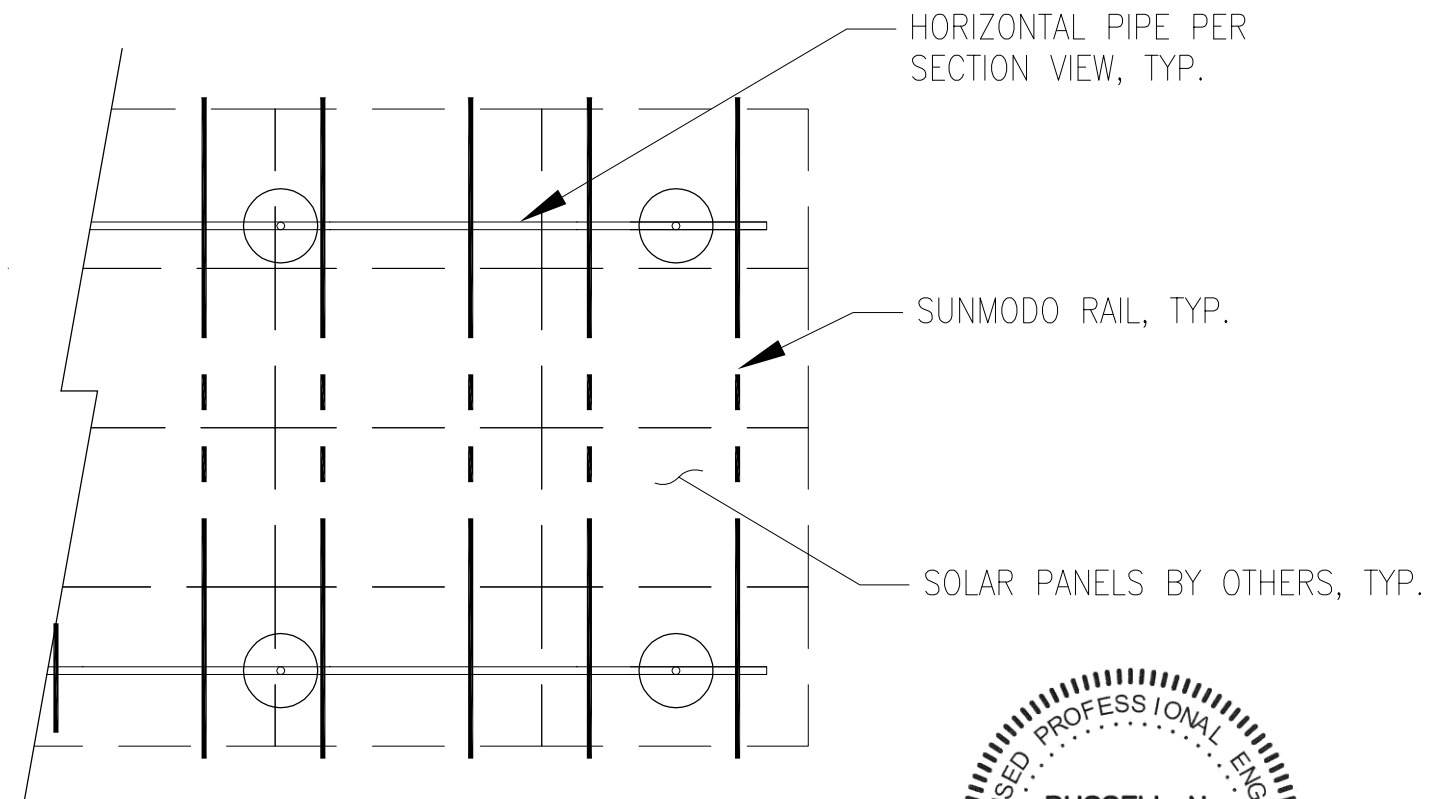
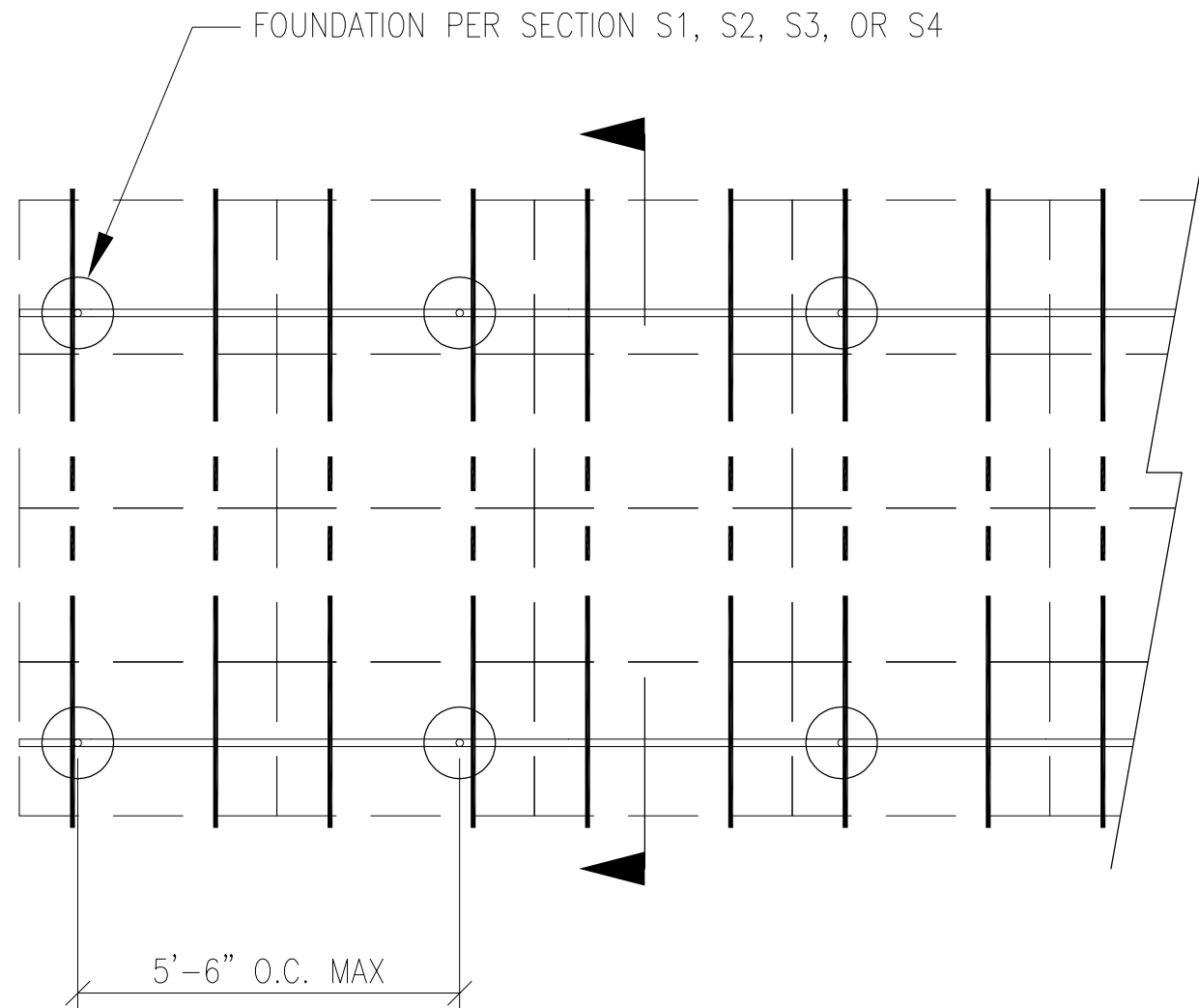

08/16/2021

PV ARRAY PLAN

N.T.S.

P1

Vector Structural Engineering requires that we review each site specific install, and we are not liable for installs at site specific locations we have not reviewed.

PROJECT SUNMODO SUNTURF GROUND MOUNTS B6

SUBJECT DRILLED PIER OPTION

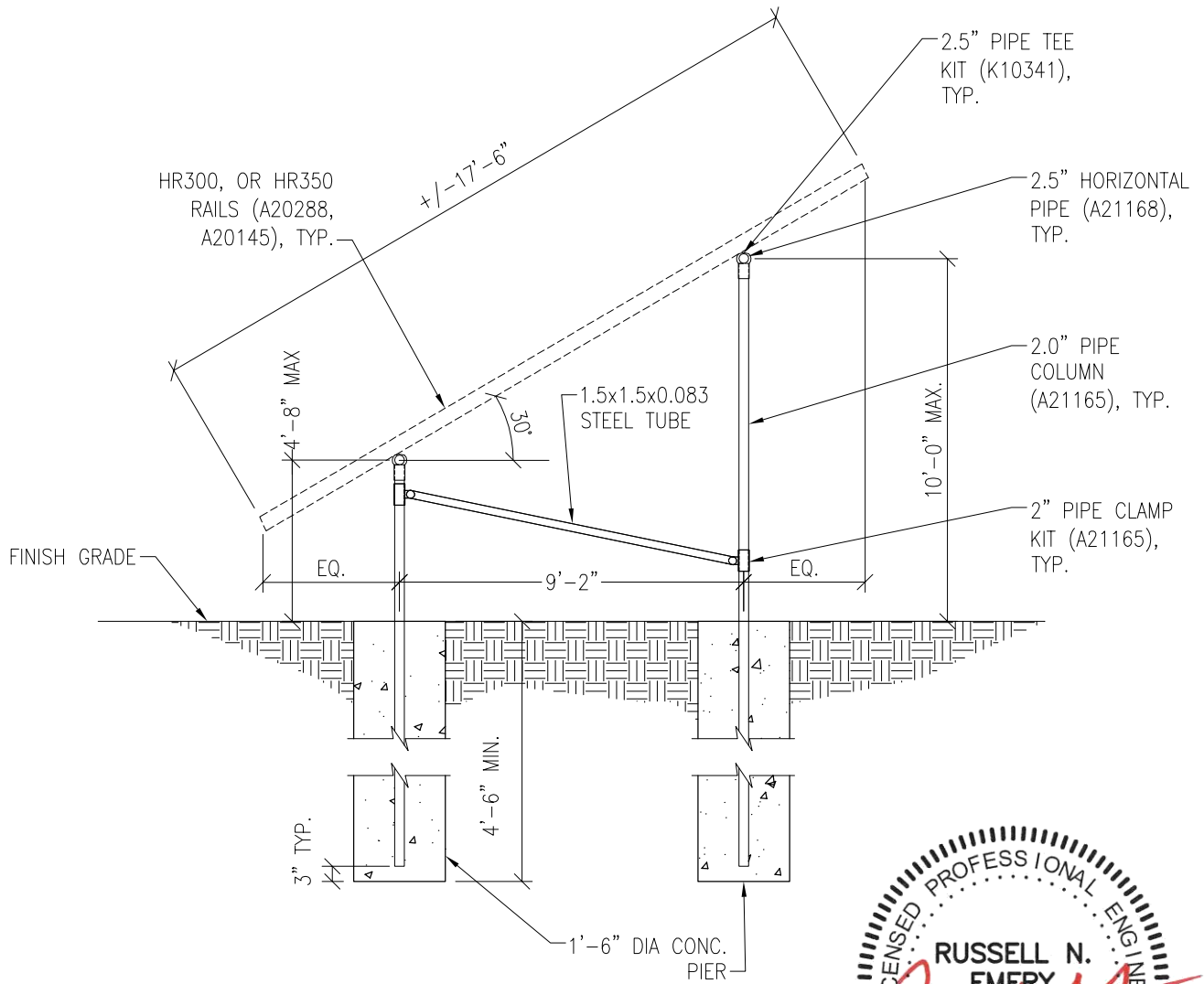

08/16/2021

Vector Structural Engineering requires that we review each site specific install, and we are not liable for installs at site specific locations we have not reviewed.

PV ARRAY SECTION

N.T.S.

S1

PROJECT SUNMODO SUNTURF GROUND MOUNTS B6

SUBJECT HELICAL PIER OPTION

NOTES:

1. For ground mount components see Section S1.
2. A minimum of (1) installed helical pier must be tested as follows:
 - 2.1. Safety factor for uplift to be 1.5
 - 2.2. S.F. for lateral loads to be 2.0
 - 2.3. Upward deflection limit = 1/2"
 - 2.4. Lateral deflection limit = 1"
 - 2.5. The load tests must be performed by an approved contractor

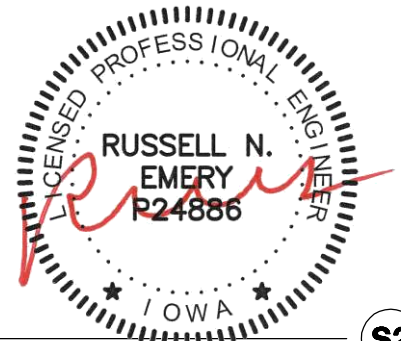
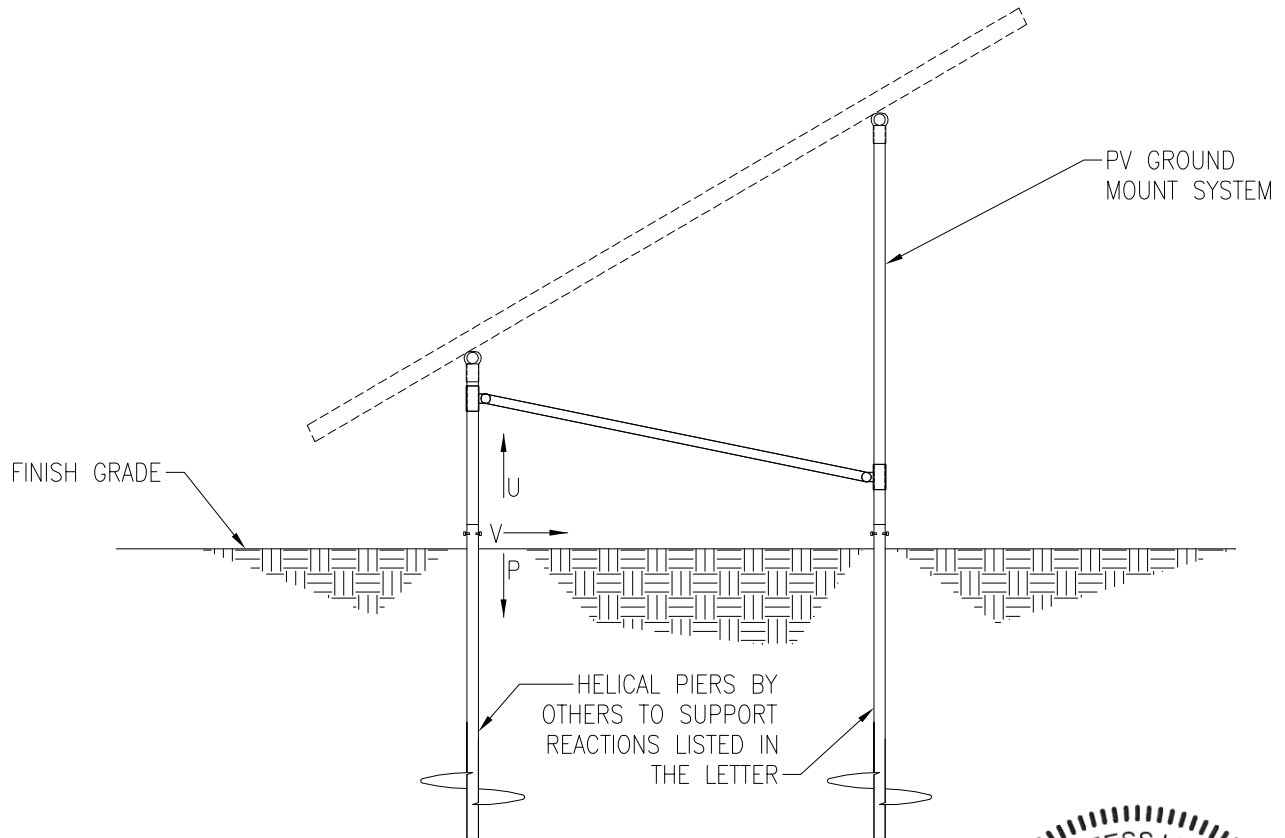

Vector Structural Engineering requires that we review each site specific install, and we are not liable for installs at site specific locations we have not reviewed.

PV ARRAY SECTION

N.T.S.

08/16/2021

S2

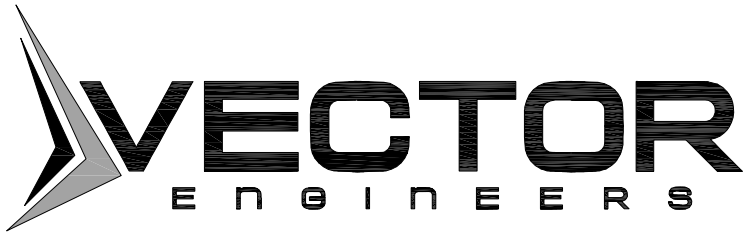

JOB NO. U2716-0319-211

PROJECT SUNMODO SUNTURF GROUND MOUNTS B6

SUBJECT GROUND SCREW OPTION

NOTES:

- 1. For ground mount components see Section S1.
- 2. A minimum of (1) installed ground screw must be tested as follows:
 - 2.1. Safety factor for uplift to be 1.5
 - 2.2. S.F. for lateral loads to be 2.0
 - 2.3. Upward deflection limit = 1/2"
 - 2.4. Lateral deflection limit = 1"
 - 2.5. The load tests must be performed by an approved contractor

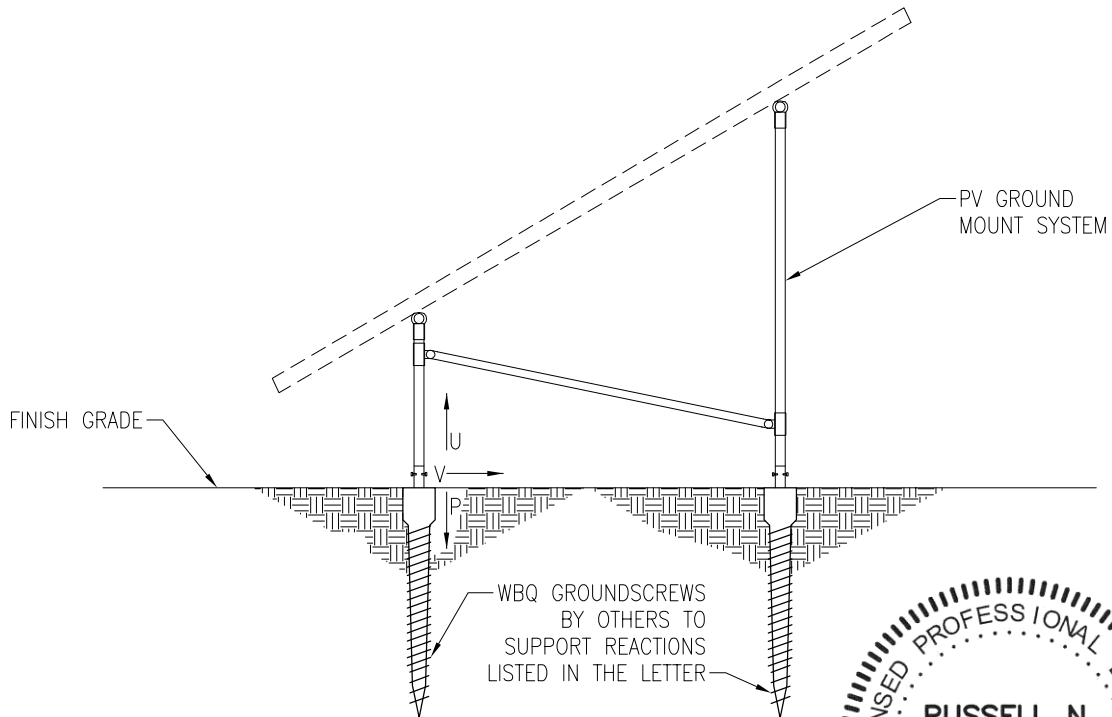

Vector Structural Engineering requires that we review each site specific install, and we are not liable for installs at site specific locations we have not reviewed.

PV ARRAY SECTION

N.T.S.

08/16/2021

S3

651 W GALENA PARK BLVD. #101
DRAPER, UTAH 84020

(801) 990-1775
(801) 990-1776 FAX

WWW.VECTORSE.COM



JOB NO. U2716-0319-211

PROJECT SUNMODO SUNTURF GROUND MOUNTS B6

SUBJECT BALLASTED BLOCK OPTION

NOTES:

1. For ground mount components see Section S1.

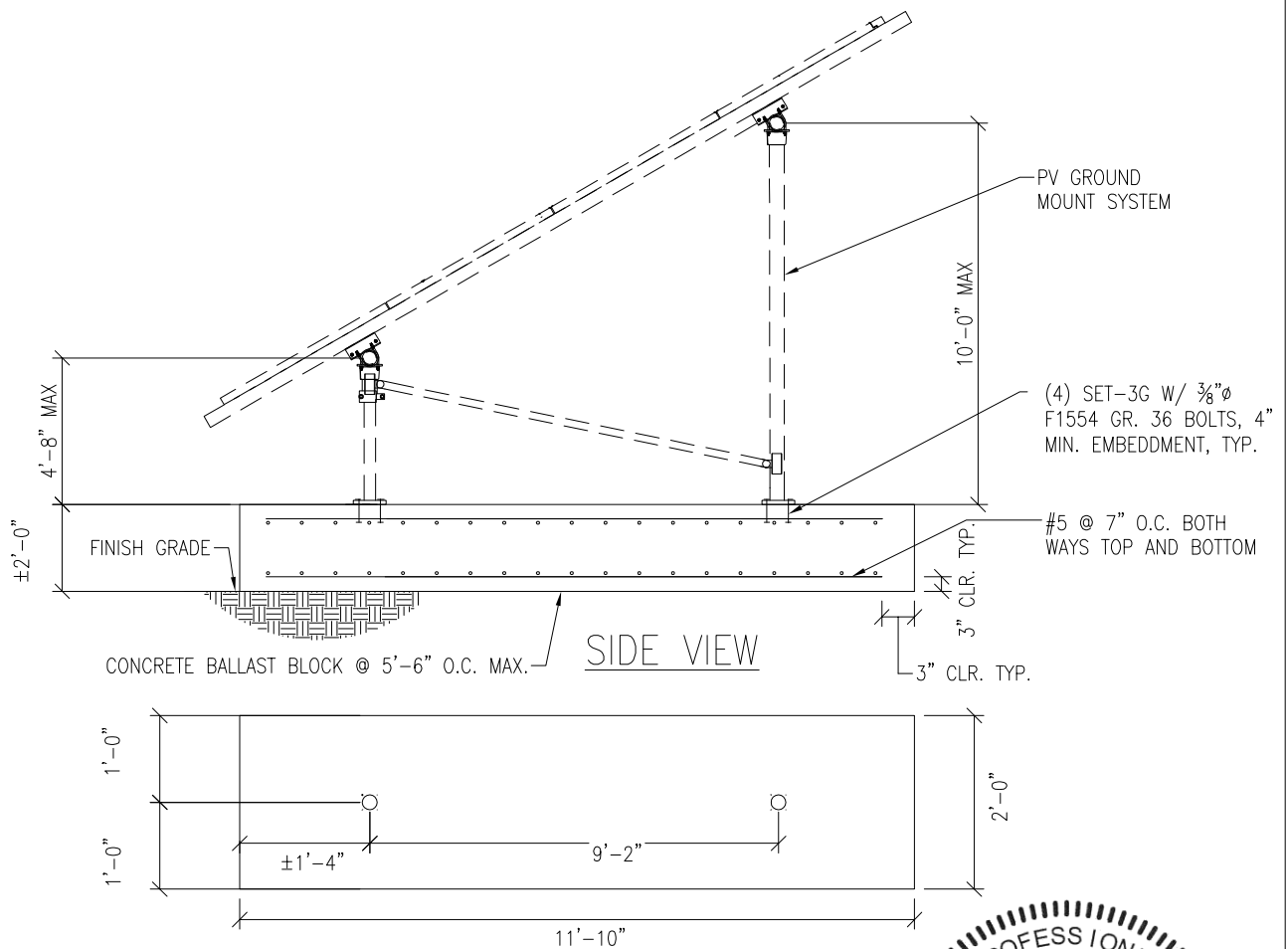

Vector Structural Engineering requires that we review each site specific install, and we are not liable for installs at site specific locations we have not reviewed.

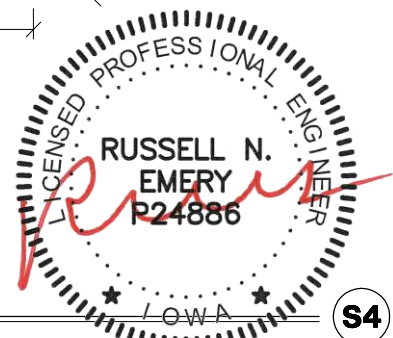

PV ARRAY SECTION

N.T.S.

S4

651 W GALENA PARK BLVD. #101
 DRAPER, UTAH 84020

(801) 990-1775
 (801) 990-1776 FAX

08/16/2021

WWW.VECTORSE.COM



JOB NO.: U2716.0319.211
SUBJECT: SNOW LOADS

PROJECT: Sunturf Package B6 Ground Mount

SNOW LOADS

Calculations Per:	ASCE 7-10	
Snow Ground Load, p_g [psf]:	30.0	(Section 7.2)
Risk Category:	I	(Table 1.5-1)
Importance Factor, I_s :	0.8	(Table 1.5-2)
Terrain Category:	C	(Section 26.7)
Exposure of Roof:	Fully Exposed	(Table 7-2)
Exposure Factor, C_e :	0.9	(Table 7-2)
Thermal Factor, C_t :	1.2	(Table 7-3)
Flat Roof Snow Load, p_f [psf]:	18	(Equation 7.3-1)
Min. Roof Snow Load, p_m [psf]:	0	(Section 7.3.4)
Panel Slope from Horizontal [°]:	30.0	
Unobstructed Slippery Surface?	Yes	(Section 7.4)
Slope Factor Figure:	Figure 7-2c	(Section 7.4)
Roof Slope Factor, C_s :	0.73	
Sloped Roof Snow Load, p_s [psf]:	13	(Equation 7.4-1)
Design Snow Load, S [psf]:	13	(1.0 Snow)



PROJECT: Sunturf Package B6 Ground Mount

WIND PRESSURES

Calculations per:	ASCE 7-10	
Design Wind Speed, V [mph]:	105	
Risk Category:	I	(Table 1.5-1)
Exposure Category:	C	(Section 26.7)
Elevation [ft]:	1217.2	
Ground Elevation Factor, K_e :		(Not applicable)
α :	9.5	(Table 26.9.1)
z_g [ft]:	900	(Table 26.9.1)
Velocity Pressure Exposure Coefficient, K_h :	0.85	(Table 27.3-1)
Topographic Factor, K_{ht} :	1.0	(Section 26.8)
Wind Directionality Factor, K_d :	0.85	(Table 26.6-1)
Internal Pressure Coefficient, GC_{pi} :	0.00	(Figure 26.11-1)
Velocity Pressure, q_h [psf]:	20.37	(Equation 27.3-1)
Gust Effect Factor, G:	0.85	(Section 26.9.1)
Panel Slope [degrees]:	30.0	
Wind Flow:	Clear	
Roof Configuration:	Monoslope	

Wind Pressures in Transverse (N-S) Direction

Net Pressure Coefficients per Figure 27.4-4

Clear Wind Flow	C_{NW}	C_{NL}
Case 1 ($\gamma = 0^\circ$, Load Case A)	-1.8	-1.8
Case 2 ($\gamma = 0^\circ$, Load Case B)	-2.5	-0.5
Case 3 ($\gamma = 180^\circ$, Load Case A)	2.1	2.1
Case 4 ($\gamma = 180^\circ$, Load Case B)	2.6	1.0

Design Wind Pressures per Equation 27.4-3 [psf]

Clear Wind Flow	$q_h GC_{NW}$	$q_h GC_{NL}$
Case 1 ($\gamma = 0^\circ$, Load Case A)	-31.2	-31.2
Case 2 ($\gamma = 0^\circ$, Load Case B)	-43.3	-8.7
Case 3 ($\gamma = 180^\circ$, Load Case A)	36.4	36.4
Case 4 ($\gamma = 180^\circ$, Load Case B)	45.0	17.3
Case 5 ($\gamma = 0^\circ$, 16 psf Min. Horiz.)	-16.0	-16.0
Case 6 ($\gamma = 180^\circ$, 16 psf Min. Horiz.)	16.0	16.0



JOB NO.: U2716-0319-211

DESIGNED: STB

Foundation Option 1: Drilled Concrete Pier



PROJECT: Sunturf Package B6 Ground Mount

DRILLED CONCRETE PIER DESIGN

Column Reactions:

Max. Shear, V [k]:	1.2	Max. Down, P _d [k]:	2.4
Max. Moment, M [k-ft]:	0.0	Max. Uplift, P _u [k]:	1.7

Pier Properties:

Pier Shape:	Round	Volume of Concrete [ft ³]:	8
Pier Diameter, b [ft]:	1.5	Volume of Concrete [yd ³]:	0.3
Top of Pier Elevation [ft]:	0.00	Weight of Concrete [k]:	1.2
Pier Depth, d [ft]:	4.5		

Soil Properties:

Allow. Bearing Pressure [psf]:	1,500	<u>Optional Parameters for Uplift:</u>	
1/3 increase for short term loads?	No		
Lateral Bearing, S [pcf]:	150	Skin Friction* [psf]:	250
Max. Lateral Bearing (opt'l) [psf]:		Top Length to Ignore [ft]:	0
Top Depth to Ignore [ft]:	0	1/3 increase for short term loads?	No
1/3 increase for short term loads?	No	Combine w/ Bearing:	No
1/2" deflection at t/o pier allowed:	Yes		

*per IBC Section 1810.3.3.1.4

Check Bearing:

Bearing Capacity [k]:	5.3
-----------------------	-----

Bearing capacity OK.

Check Uplift:

Uplift Capacity [k]:	6.4
----------------------	-----

Uplift capacity OK.

Check Lateral Bearing:

Top of Pier Constrained?:	No	IBC Section 1807.3.2.1
Applied Lateral Force, P [lb]:	1,153	
Point of Application, h [ft]:	0.0	
S _{max} [psf]:		
S [psf]:	450	
A = 2.34*P/(S _b):	4.00	
Required Pier Depth, d _{reqd} [ft]:	4.00	IBC Eq. 18-1

Result: **Lateral bearing capacity OK.**

Foundation Option 2: Helical Pier

The ground screws and helical piers must be tested to 1.5 times uplift and 2.0 times lateral reactions found in the table below. A minimum of one ground screw or helical pier must be tested.

Load (ASD)	Value (lbs)	Factor of Safety	Test Value (lbs)
UPLIFT	1681	1.5	2522
LATERAL	1153	2	2306

Foundation Option 3: Ground Screw

The ground screws and helical piers must be tested to 1.5 times uplift and 2.0 times lateral reactions found in the table below. A minimum of one ground screw or helical pier must be tested.

Load (ASD)	Value (lbs)	Factor of Safety	Test Value (lbs)
UPLIFT	1681	1.5	2522
LATERAL	1153	2	2306



JOB NO.: U2716-0319-211

DESIGNED: STB

Foundation Option 4: Ballasted Block

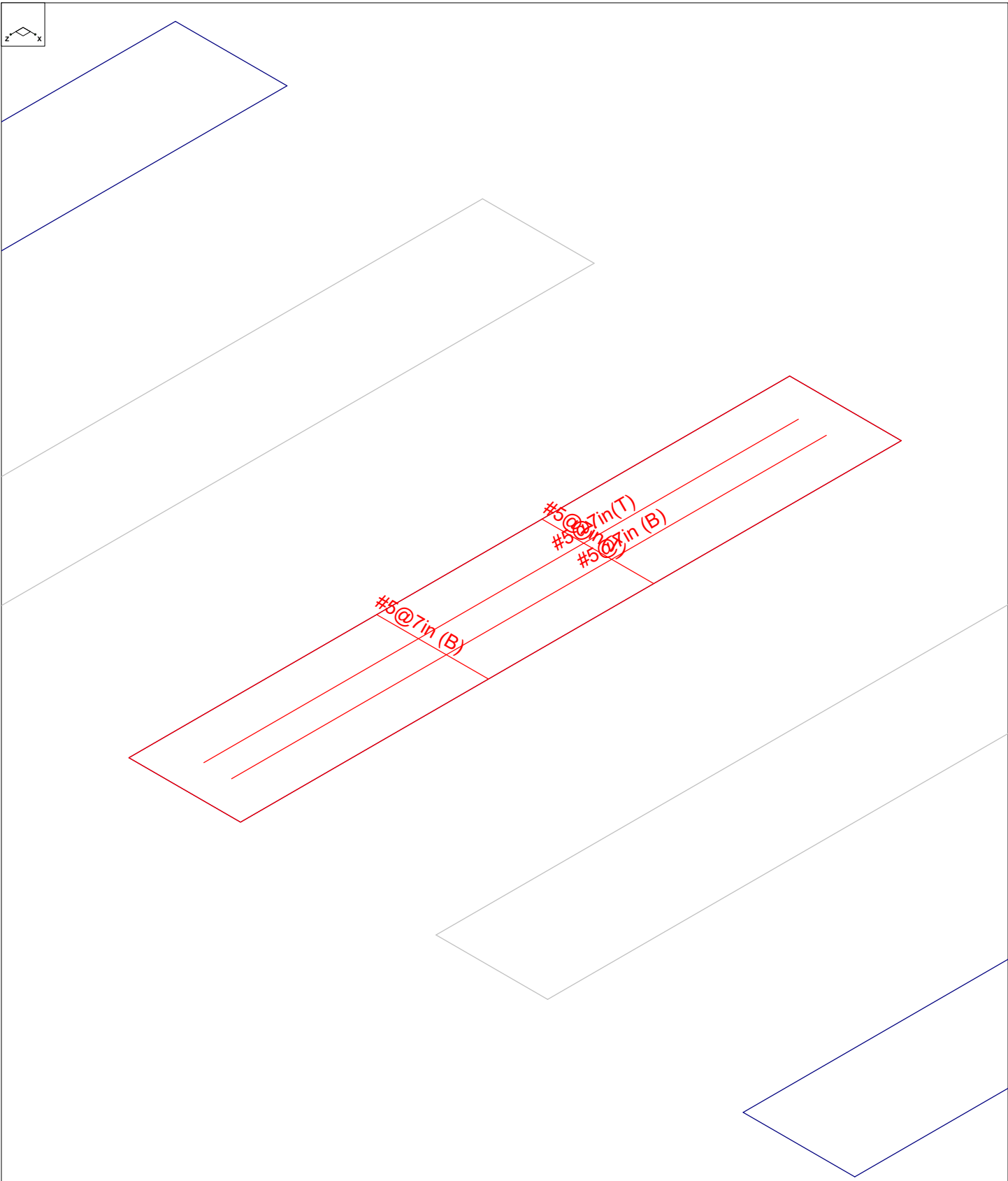

Results for LC 2, 1.0 D

Vector Structural Engineeri...	Ground Mount	SK - 1
STB		Aug 16, 2021 at 4:09 PM
U2716.0319.211		Sunturf Ground Mount B6 82x42.r3d

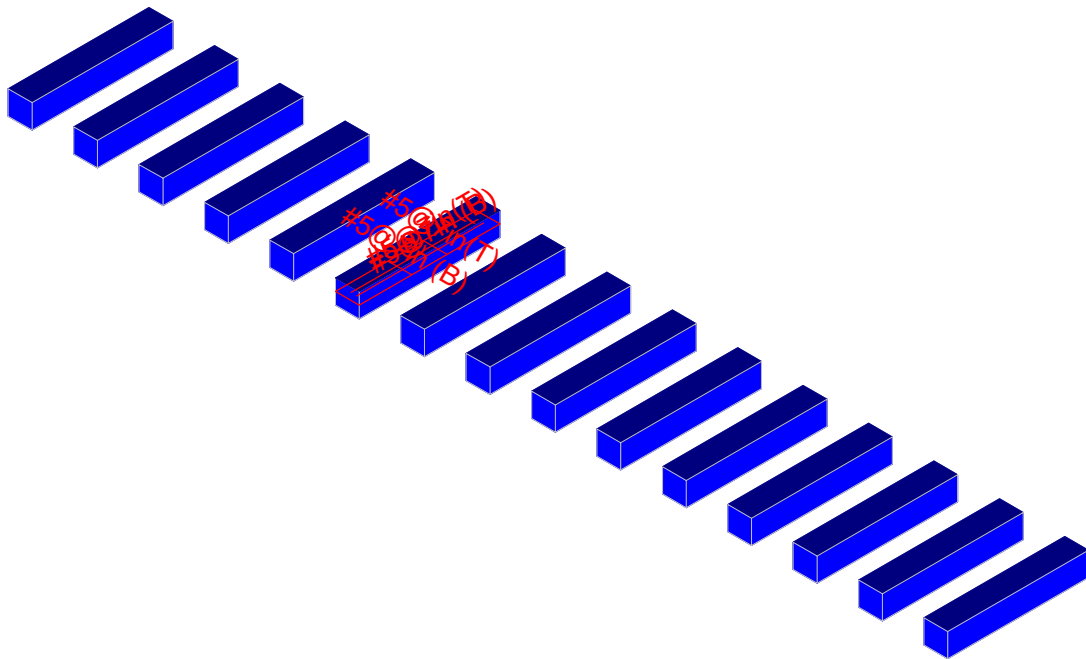

Results for LC 2, 1.0 D

Vector Structural Engineeri..	Ground Mount	SK - 2
STB		Aug 16, 2021 at 4:10 PM
U2716.0319.211		Sunturf Ground Mount B6 82x42.r3d



Company : Vector Structural Engineering
 Designer : STB
 Job Number : U2716.0319.211
 Model Name : Ground Mount

Aug 16, 2021
 4:11 PM
 Checked By: _____

Slabs (Continued)

	Label	Thickness [in]	Material	Local Axis Angle ...	Analysis Offset [in]	Passive Pressur...	Soil Overburden [psf]
9	S9	24	Conc2500NW	0	0	0	0
10	S10	24	Conc2500NW	0	0	0	0
11	S11	24	Conc2500NW	0	0	0	0
12	S12	24	Conc2500NW	0	0	0	0
13	S13	24	Conc2500NW	0	0	0	0
14	S14	24	Conc2500NW	0	0	0	0
15	S15	24	Conc2500NW	0	0	0	0

Load Combinations

Label	Solve	Service	A..SF	Ca...Fa...	Ca...Fa...	Ca...Fa...	Ca...Fa...	Ca...Fa...	Ca...Fa...	Ca...Fa...	Ca...Fa...	Ca...Fa...	Ca...Fa...	Ca...Fa...	Ca...Fa...	Ca...Fa...	Ca...Fa...	C... F...	C... F...	C... F...
1	ASD Loads																			
2	1.0 D	Yes	Yes	1.5	DL 1															
3	1.0 D + 1.0 S	Yes	Yes	1.5	DL 1	RLL 1														
4	1.0 D + 0.6 W1	Yes	Yes	1.5	DL 1	RLL	OL1 .6													
5	1.0 D + 0.6 W2	Yes	Yes	1.5	DL 1	RLL	OL2 .6													
6	1.0 D + 0.6 W3	Yes	Yes	1.5	DL 1	RLL	OL3 .6													
7	1.0 D + 0.6 W4	Yes	Yes	1.5	DL 1	RLL	OL4 .6													
8	1.0 D + 0.45 ...	Yes	Yes	1.5	DL 1	RLL .75	OL1 .45													
9	1.0 D + 0.45 ...	Yes	Yes	1.5	DL 1	RLL .75	OL2 .45													
10	1.0 D + 0.45 ...	Yes	Yes	1.5	DL 1	RLL .75	OL3 .45													
11	1.0 D + 0.45 ...	Yes	Yes	1.5	DL 1	RLL .75	OL4 .45													
12	0.6 D + 0.6 W1	Yes	Yes		DL .6	RLL	OL1 .6													
13	0.6 D + 0.6 W2	Yes	Yes		DL .6	RLL	OL2 .6													
14	0.6 D + 0.6 W3	Yes	Yes		DL .6	RLL	OL3 .6													
15	0.6 D + 0.6 W4	Yes	Yes		DL .6	RLL	OL4 .6													
16																				
17	LRFD Loads																			
18	1.4 D	Yes			DL 1.4	RLL														
19	1.2 D + 1.6 S...	Yes			DL 1.2	RLL 1.6	OL1 .5													
20	1.2 D + 1.6 S...	Yes			DL 1.2	RLL 1.6	OL2 .5													
21	1.2 D + 1.6 S...	Yes			DL 1.2	RLL 1.6	OL3 .5													
22	1.2 D + 1.6 S...	Yes			DL 1.2	RLL 1.6	OL4 .5													
23	1.2 D + 1.0 W1	Yes			DL 1.2	RLL	OL1 1													
24	1.2 D + 1.0 W2	Yes			DL 1.2	RLL	OL2 1													
25	1.2 D + 1.0 W3	Yes			DL 1.2	RLL	OL3 1													
26	1.2 D + 1.0 W4	Yes			DL 1.2	RLL	OL4 1													
27	0.9 D + 1.0 W1	Yes			DL .9	RLL	OL1 1													
28	0.9 D + 1.0 W2	Yes			DL .9	RLL	OL2 1													
29	0.9 D + 1.0 W3	Yes			DL .9	RLL	OL3 1													
30	0.9 D + 1.0 W4	Yes			DL .9	RLL	OL4 1													

Design Strips

Label	Rebar Angle from Pl...	No. of Design Cuts	Design Rule	
1	DS1	0	50	Typical
2	DS2	90	50	Typical

Strip Reinforcing

Label	UC Top	LC	Top Bars	Governing ...	UC Bot	LC	Bot B...	Gover...	UC Shear	LC	Governing De...	
1	DS1	.029	21	#5@7in	DS1-X25	.023	28	#5@7in	DS1-...	.042	21	DS1-X13
2	DS2	0	27	#5@7in	DS2-X25	.002	21	#5@7in	DS2-...	.006	21	DS2-X50



Company : Vector Structural Engineering
 Designer : STB
 Job Number : U2716.0319.211
 Model Name : Ground Mount

Aug 16, 2021
 4:11 PM
 Checked By: _____

Slab Overturning Safety Factors (By Combination)

LC	Slab	Angle[deg]	Mo-xx[lb-ft]	Ms-xx[lb-ft]	Mo-zz[lb-ft]	Ms-zz[lb-ft]	Ms-xx/Mo-xx	Ms-zz/Mo-zz
1	2	S1	0	0	42857.141	0	7271.075	9.999+
2	2	S2	0	0	42995.014	0	7269.21	9.999+
3	2	S3	0	0	42973.744	0	7274.548	9.999+
4	2	S4	0	0	42986.743	0	7279.201	9.999+
5	2	S5	0	0	42937.002	0	7271.054	9.999+
6	2	S6	0	0	42943.801	0	7266.593	9.999+
7	2	S7	0	0	42988.518	0	7273.508	9.999+
8	2	S8	0	0	42972.717	0	7273.477	9.999+
9	2	S9	0	0	42988.517	0	7279.027	9.999+
10	2	S10	0	0	42943.799	0	7272.529	9.999+
11	2	S11	0	0	42937.022	0	7266.188	9.999+
12	2	S12	0	0	42986.699	0	7272.474	9.999+
13	2	S13	0	0	42974.097	0	7274.528	9.999+
14	2	S14	0	0	42994.016	0	7273.839	9.999+
15	2	S15	0	0	42856.989	0	7265.507	9.999+
16	3	S1	0	0	53028.958	0	9043.413	9.999+
17	3	S2	0	0	54066.935	0	9074.637	9.999+
18	3	S3	0	0	53875.896	0	9119.118	9.999+
19	3	S4	0	0	53972.68	0	9154.936	9.999+
20	3	S5	0	0	53632.104	0	9098.172	9.999+
21	3	S6	0	0	53678.658	0	9059.181	9.999+
22	3	S7	0	0	53983.779	0	9106.791	9.999+
23	3	S8	0	0	53875.952	0	9110.858	9.999+
24	3	S9	0	0	53983.768	0	9153.008	9.999+
25	3	S10	0	0	53678.64	0	9109.062	9.999+
26	3	S11	0	0	53632.238	0	9057.364	9.999+
27	3	S12	0	0	53972.331	0	9098.535	9.999+
28	3	S13	0	0	53878.551	0	9119.01	9.999+
29	3	S14	0	0	54059.3	0	9107.241	9.999+
30	3	S15	0	0	53027.954	0	9012.028	9.999+
31	4	S1	0	16889.872	43151.282	1537.569	7271.075	2.555
32	4	S2	0	17740.721	43051.04	1551.396	7273.765	2.427
33	4	S3	0	17292.046	43108.527	1572.226	7274.548	2.493
34	4	S4	0	18255.849	43110.764	1590.297	7279.201	2.361
35	4	S5	0	17241.002	43075.121	1550.995	7271.054	2.498
36	4	S6	0	17376.601	43079.457	1556.706	7272.529	2.479
37	4	S7	0	18237.541	43114.1	1590.769	7279.026	2.364
38	4	S8	0	17187.308	43096.879	1563.84	7273.477	2.507
39	4	S9	0	18237.661	43114.1	1590.959	7279.027	2.364
40	4	S10	0	17376.836	43079.465	1556.906	7272.529	2.479
41	4	S11	0	17240.428	43075.116	1550.785	7271.055	2.498
42	4	S12	0	18259.476	43110.865	1590.204	7279.207	2.361
43	4	S13	0	17272.667	43107.94	1571.657	7274.528	2.496
44	4	S14	0	17840.772	43052.8	1551.285	7273.839	2.413
45	4	S15	0	16950.137	43151.036	1538.458	7271.04	2.546
46	5	S1	0	18497.709	43151.282	1354.854	7271.075	2.333
47	5	S2	0	19429.839	43051.04	1270.705	7273.765	2.216
48	5	S3	0	18750.084	43108.527	1325.53	7274.548	2.299
49	5	S4	0	19977.914	43110.764	1328.538	7279.201	2.158
50	5	S5	0	18727.221	43075.121	1302.342	7271.054	2.3
51	5	S6	0	18896.888	43079.457	1304.796	7272.529	2.28
52	5	S7	0	19948.608	43114.1	1332.204	7279.026	2.161
53	5	S8	0	18645.105	43096.879	1315.643	7273.477	2.311
54	5	S9	0	19948.745	43114.1	1332.328	7279.027	2.161
55	5	S10	0	18897.015	43079.465	1304.932	7272.529	2.28
56	5	S11	0	18727.125	43075.116	1302.207	7271.055	2.3
57	5	S12	0	19979.45	43110.865	1328.594	7279.207	2.158



Company : Vector Structural Engineering
 Designer : STB
 Job Number : U2716.0319.211
 Model Name : Ground Mount

Aug 16, 2021
 4:11 PM
 Checked By: _____

Slab Overturning Safety Factors (By Combination) (Continued)

LC	Slab	Angle[deg]	Mo-xx[lb-ft]	Ms-xx[lb-ft]	Mo-zz[lb-ft]	Ms-zz[lb-ft]	Ms-xx/Mo-xx	Ms-zz/Mo-zz	
58	5	S13	0	18742.664	43107.94	1324.083	7274.528	2.3	5.494
59	5	S14	0	19464.031	43052.8	1271.278	7273.839	2.212	5.722
60	5	S15	0	18511.552	43151.036	1355.242	7271.04	2.331	5.365
61	6	S1	0	0	43931.463	0	9064.905	9.999+	9.999+
62	6	S2	0	0	43554.21	0	9051.924	9.999+	9.999+
63	6	S3	0	0	44474.516	0	9108.812	9.999+	9.999+
64	6	S4	0	0	43399.967	0	9134.548	9.999+	9.999+
65	6	S5	0	0	44110.693	0	9080.549	9.999+	9.999+
66	6	S6	0	0	44009.741	0	9056.962	9.999+	9.999+
67	6	S7	0	0	43457.123	0	9092.941	9.999+	9.999+
68	6	S8	0	0	44510.572	0	9097.957	9.999+	9.999+
69	6	S9	0	0	43456.943	0	9135.145	9.999+	9.999+
70	6	S10	0	0	44009.585	0	9088.92	9.999+	9.999+
71	6	S11	0	0	44111.247	0	9054.914	9.999+	9.999+
72	6	S12	0	0	43396.581	0	9086.967	9.999+	9.999+
73	6	S13	0	0	44495.02	0	9103.858	9.999+	9.999+
74	6	S14	0	0	43437.878	0	9083.672	9.999+	9.999+
75	6	S15	0	0	43859.637	0	8982.377	9.999+	9.999+
76	7	S1	0	2252.674	42857.141	0	8865.059	9.999+	9.999+
77	7	S2	0	3382.79	42995.014	0	8787.631	9.999+	9.999+
78	7	S3	0	2039.031	42973.744	0	8856.536	9.999+	9.999+
79	7	S4	0	3355.241	42986.743	0	8870.274	9.999+	9.999+
80	7	S5	0	2328.125	42937.002	0	8827.446	9.999+	9.999+
81	7	S6	0	2475.08	42943.801	0	8817.778	9.999+	9.999+
82	7	S7	0	3290.581	42988.518	0	8844.143	9.999+	9.999+
83	7	S8	0	2026.449	42972.717	0	8844.772	9.999+	9.999+
84	7	S9	0	3290.778	42988.517	0	8872.663	9.999+	9.999+
85	7	S10	0	2475.15	42943.799	0	8832.953	9.999+	9.999+
86	7	S11	0	2327.946	42937.022	0	8815.679	9.999+	9.999+
87	7	S12	0	3356.963	42986.699	0	8839.781	9.999+	9.999+
88	7	S13	0	2029.408	42974.097	0	8853.135	9.999+	9.999+
89	7	S14	0	3438.154	42994.016	0	8806.344	9.999+	9.999+
90	7	S15	0	2287.971	42856.989	0	8737.959	9.999+	9.999+
91	8	S1	0	12667.404	51137.812	1153.177	8600.329	4.037	7.458
92	8	S2	0	13305.541	50893.423	1163.547	8648.647	3.825	7.433
93	8	S3	0	12969.034	51302.495	1179.17	8657.975	3.956	7.342
94	8	S4	0	13691.887	51298.027	1192.723	8686.002	3.747	7.282
95	8	S5	0	12930.752	51110.021	1163.246	8641.393	3.953	7.429
96	8	S6	0	13032.451	51132.607	1167.529	8649.936	3.923	7.409
97	8	S7	0	13678.156	51318.722	1193.077	8684.523	3.752	7.279
98	8	S8	0	12890.481	51226.232	1172.88	8651.513	3.974	7.376
99	8	S9	0	13678.245	51318.727	1193.219	8684.513	3.752	7.278
100	8	S10	0	13032.627	51132.651	1167.68	8649.929	3.923	7.408
101	8	S11	0	12930.321	51109.995	1163.089	8641.408	3.953	7.43
102	8	S12	0	13694.607	51298.553	1192.653	8686.037	3.746	7.283
103	8	S13	0	12954.5	51299.399	1178.743	8657.89	3.96	7.345
104	8	S14	0	13380.579	50901.608	1163.464	8648.891	3.804	7.434
105	8	S15	0	12712.603	51137.258	1153.844	8600.207	4.023	7.454
106	9	S1	0	13873.282	51137.812	1016.141	8600.329	3.686	8.464
107	9	S2	0	14572.379	50893.423	953.029	8648.647	3.492	9.075
108	9	S3	0	14062.563	51302.495	994.147	8657.975	3.648	8.709
109	9	S4	0	14983.435	51298.027	996.404	8686.002	3.424	8.717
110	9	S5	0	14045.416	51110.021	975.723	8609.571	3.639	8.824
111	9	S6	0	14172.666	51132.607	976.965	8611.034	3.608	8.814
112	9	S7	0	14961.456	51318.722	999.153	8684.523	3.43	8.692
113	9	S8	0	13983.829	51226.232	986.732	8651.513	3.663	8.768
114	9	S9	0	14961.559	51318.727	999.246	8684.513	3.43	8.691



Company : Vector Structural Engineering
 Designer : STB
 Job Number : U2716.0319.211
 Model Name : Ground Mount

Aug 16, 2021
 4:11 PM
 Checked By: _____

Slab Overturning Safety Factors (By Combination) (Continued)

LC	Slab	Angle[deg]	Mo-xx[lb-ft]	Ms-xx[lb-ft]	Mo-zz[lb-ft]	Ms-zz[lb-ft]	Ms-xx/Mo-xx	Ms-zz/Mo-zz	
172	13	S7	0	19948.608	25868.46	1332.204	4367.416	1.297	3.278
173	13	S8	0	18645.105	25858.127	1315.643	4364.086	1.387	3.317
174	13	S9	0	19948.745	25868.46	1332.328	4367.416	1.297	3.278
175	13	S10	0	18897.015	25847.679	1304.932	4363.518	1.368	3.344
176	13	S11	0	18727.125	25845.07	1302.207	4362.633	1.38	3.35
177	13	S12	0	19979.45	25866.519	1328.594	4367.524	1.295	3.287
178	13	S13	0	18742.664	25864.764	1324.083	4364.717	1.38	3.296
179	13	S14	0	19464.031	25831.68	1271.278	4364.303	1.327	3.433
180	13	S15	0	18511.552	25890.622	1355.242	4362.624	1.399	3.219
181	14	S1	0	0	26788.607	0	6156.475	9.999+	9.999+
182	14	S2	0	0	26356.204	0	6144.24	9.999+	9.999+
183	14	S3	0	0	27285.019	0	6198.992	9.999+	9.999+
184	14	S4	0	0	26205.27	0	6222.867	9.999+	9.999+
185	14	S5	0	0	26935.892	0	6172.127	9.999+	9.999+
186	14	S6	0	0	26832.22	0	6150.325	9.999+	9.999+
187	14	S7	0	0	26261.716	0	6183.538	9.999+	9.999+
188	14	S8	0	0	27321.486	0	6188.566	9.999+	9.999+
189	14	S9	0	0	26261.536	0	6223.535	9.999+	9.999+
190	14	S10	0	0	26832.066	0	6179.908	9.999+	9.999+
191	14	S11	0	0	26936.438	0	6148.439	9.999+	9.999+
192	14	S12	0	0	26201.901	0	6177.977	9.999+	9.999+
193	14	S13	0	0	27305.381	0	6194.047	9.999+	9.999+
194	14	S14	0	0	26240.271	0	6174.136	9.999+	9.999+
195	14	S15	0	0	26716.841	0	6076.174	9.999+	9.999+
196	15	S1	0	2252.674	25714.285	0	5956.629	9.999+	9.999+
197	15	S2	0	3382.79	25797.009	0	5879.947	7.626	9.999+
198	15	S3	0	2039.031	25784.246	0	5946.717	9.999+	9.999+
199	15	S4	0	3355.241	25792.046	0	5958.593	7.687	9.999+
200	15	S5	0	2328.125	25762.201	0	5919.025	9.999+	9.999+
201	15	S6	0	2475.08	25766.281	0	5911.141	9.999+	9.999+
202	15	S7	0	3290.581	25793.111	0	5934.74	7.838	9.999+
203	15	S8	0	2026.449	25783.63	0	5935.382	9.999+	9.999+
204	15	S9	0	3290.778	25793.11	0	5961.052	7.838	9.999+
205	15	S10	0	2475.15	25766.279	0	5923.941	9.999+	9.999+
206	15	S11	0	2327.946	25762.213	0	5909.204	9.999+	9.999+
207	15	S12	0	3356.963	25792.019	0	5930.792	7.683	9.999+
208	15	S13	0	2029.408	25784.458	0	5943.324	9.999+	9.999+
209	15	S14	0	3438.154	25796.41	0	5896.808	7.503	9.999+
210	15	S15	0	2287.971	25714.193	0	5831.756	9.999+	9.999+

Slab Sliding Safety Factors

LC	Slab	Angle[deg]	Va-xx[lb]	Vr-xx[lb]	Va-zz[lb]	Vr-zz[lb]	SR-xx	SR-zz	
1	2	S1	0	1.384	2180.492	0	2180.492	9.999+	9.999+
2	2	S2	0	1.139	2181.446	0	2181.446	9.999+	9.999+
3	2	S3	0	0	2182.364	0	2182.364	9.999+	9.999+
4	2	S4	0	1.683	2182.751	0	2182.751	9.999+	9.999+
5	2	S5	0	1.217	2180.586	0	2180.586	9.999+	9.999+
6	2	S6	0	1.484	2180.868	0	2180.868	9.999+	9.999+
7	2	S7	0	1.38	2182.88	0	2182.88	9.999+	9.999+
8	2	S8	0	0	2182.043	0	2182.043	9.999+	9.999+
9	2	S9	0	1.38	2182.88	0	2182.88	9.999+	9.999+
10	2	S10	0	1.484	2180.868	0	2180.868	9.999+	9.999+
11	2	S11	0	1.217	2180.586	0	2180.586	9.999+	9.999+
12	2	S12	0	1.683	2182.752	0	2182.752	9.999+	9.999+
13	2	S13	0	0	2182.358	0	2182.358	9.999+	9.999+
14	2	S14	0	1.144	2181.466	0	2181.466	9.999+	9.999+



Company : Vector Structural Engineering
 Designer : STB
 Job Number : U2716.0319.211
 Model Name : Ground Mount

Aug 16, 2021
 4:11 PM
 Checked By: _____

Slab Sliding Safety Factors (Continued)

	LC	Slab	Angle[deg]	Va-xx[lb]	Vr-xx[lb]	Va-zz[lb]	Vr-zz[lb]	SR-xx	SR-zz
15	2	S15	0	1.383	2180.482	0	2180.482	9.999+	9.999+
16	3	S1	0	7.814	2708.336	0	2708.336	9.999+	9.999+
17	3	S2	0	8.076	2727.237	0	2727.237	9.999+	9.999+
18	3	S3	0	0	2735.735	0	2735.735	9.999+	9.999+
19	3	S4	0	14.103	2738.019	0	2738.019	9.999+	9.999+
20	3	S5	0	10.201	2723.331	0	2723.331	9.999+	9.999+
21	3	S6	0	12.473	2725.238	0	2725.238	9.999+	9.999+
22	3	S7	0	11.558	2738.972	0	2738.972	9.999+	9.999+
23	3	S8	0	0	2733.257	0	2733.257	9.999+	9.999+
24	3	S9	0	11.551	2738.972	0	2738.972	9.999+	9.999+
25	3	S10	0	12.466	2725.239	0	2725.239	9.999+	9.999+
26	3	S11	0	10.207	2723.333	0	2723.333	9.999+	9.999+
27	3	S12	0	14.111	2738.027	0	2738.027	9.999+	9.999+
28	3	S13	0	0	2735.703	0	2735.703	9.999+	9.999+
29	3	S14	0	8.113	2727.305	0	2727.305	9.999+	9.999+
30	3	S15	0	7.809	2708.294	0	2708.294	9.999+	9.999+
31	4	S1	0	14.836	1728.953	839.385	1728.953	9.999+	2.06
32	4	S2	0	4.7	1719.531	938.674	1719.531	9.999+	1.832
33	4	S3	0	1.11	1711.363	864.332	1711.363	9.999+	1.98
34	4	S4	0	7.127	1710.947	942.322	1710.947	9.999+	1.816
35	4	S5	0	3.281	1717.986	875.958	1717.986	9.999+	1.961
36	4	S6	0	4.042	1717.172	884.749	1717.172	9.999+	1.941
37	4	S7	0	6.434	1710.338	939.315	1710.338	9.999+	1.821
38	4	S8	0	0	1712.891	861.84	1712.891	9.999+	1.987
39	4	S9	0	6.53	1710.339	939.332	1710.339	9.999+	1.821
40	4	S10	0	4.138	1717.17	884.745	1717.17	9.999+	1.941
41	4	S11	0	3.181	1717.989	875.995	1717.989	9.999+	1.961
42	4	S12	0	7.048	1710.93	942.238	1710.93	9.999+	1.816
43	4	S13	0	.915	1711.41	864.365	1711.41	9.999+	1.98
44	4	S14	0	4.589	1719.52	938.901	1719.52	9.999+	1.831
45	4	S15	0	15.331	1728.973	839.228	1728.973	9.999+	2.06
46	5	S1	0	29.443	1792.532	700.779	1792.532	9.999+	2.558
47	5	S2	0	.155	1801.011	803.55	1801.011	9.999+	2.241
48	5	S3	0	.616	1785.075	712.994	1785.075	9.999+	2.504
49	5	S4	0	1.728	1786.236	809.158	1786.236	9.999+	2.208
50	5	S5	0	.872	1790.09	728.535	1790.09	9.999+	2.457
51	5	S6	0	.94	1789.756	739.386	1789.756	9.999+	2.421
52	5	S7	0	2.52	1785.558	805.344	1785.558	9.999+	2.217
53	5	S8	0	0	1787.35	710.267	1787.35	9.999+	2.516
54	5	S9	0	2.583	1785.56	805.359	1785.56	9.999+	2.217
55	5	S10	0	.876	1789.754	739.386	1789.754	9.999+	2.421
56	5	S11	0	.937	1790.092	728.555	1790.092	9.999+	2.457
57	5	S12	0	1.731	1786.222	809.149	1786.222	9.999+	2.208
58	5	S13	0	0	1785.134	712.985	1785.134	9.999+	2.504
59	5	S14	0	.185	1800.88	803.713	1800.88	9.999+	2.241
60	5	S15	0	29.842	1792.644	700.669	1792.644	9.999+	2.558
61	6	S1	0	20.307	2707.287	979.282	2707.287	9.999+	2.765
62	6	S2	0	7.951	2720.348	1095.119	2720.348	9.999+	2.484
63	6	S3	0	1.295	2731.866	1008.387	2731.866	9.999+	2.709
64	6	S4	0	11.961	2733.188	1099.376	2733.188	9.999+	2.486
65	6	S5	0	6.464	2720.286	1021.951	2720.286	9.999+	2.662
66	6	S6	0	7.931	2721.847	1032.207	2721.847	9.999+	2.637
67	6	S7	0	10.496	2734.18	1095.868	2734.18	9.999+	2.495
68	6	S8	0	0	2729.387	1005.48	2729.387	9.999+	2.715
69	6	S9	0	10.608	2734.179	1095.887	2734.179	9.999+	2.495
70	6	S10	0	8.043	2721.85	1032.203	2721.85	9.999+	2.637
71	6	S11	0	6.348	2720.283	1021.995	2720.283	9.999+	2.662



Company : Vector Structural Engineering
 Designer : STB
 Job Number : U2716.0319.211
 Model Name : Ground Mount

Aug 16, 2021
 4:11 PM
 Checked By: _____

Slab Sliding Safety Factors (Continued)

	LC	Slab	Angle[deg]	Va-xx[lb]	Vr-xx[lb]	Va-zz[lb]	Vr-zz[lb]	SR-xx	SR-zz
72	6	S12	0	11.869	2733.212	1099.278	2733.212	9.999+	2.486
73	6	S13	0	1.067	2731.798	1008.426	2731.798	9.999+	2.709
74	6	S14	0	7.832	2720.402	1095.385	2720.402	9.999+	2.484
75	6	S15	0	20.883	2707.243	979.099	2707.243	9.999+	2.765
76	7	S1	0	31.436	2640.656	839.074	2640.656	9.999+	3.147
77	7	S2	0	4.557	2639.024	954.24	2639.024	9.999+	2.766
78	7	S3	0	.861	2656.444	857.117	2656.444	9.999+	3.099
79	7	S4	0	7.676	2656.476	959.938	2656.476	9.999+	2.767
80	7	S5	0	2.983	2646.444	873.41	2646.444	9.999+	3.03
81	7	S6	0	3.75	2647.583	885.008	2647.583	9.999+	2.992
82	7	S7	0	7.089	2657.497	955.888	2657.497	9.999+	2.78
83	7	S8	0	0	2653.432	854.108	2653.432	9.999+	3.107
84	7	S9	0	7.173	2657.495	955.906	2657.495	9.999+	2.78
85	7	S10	0	3.833	2647.586	885.007	2647.586	9.999+	2.992
86	7	S11	0	2.898	2646.442	873.438	2646.442	9.999+	3.03
87	7	S12	0	7.602	2656.496	959.902	2656.496	9.999+	2.767
88	7	S13	0	.714	2656.369	857.121	2656.369	9.999+	3.099
89	7	S14	0	4.55	2639.173	954.445	2639.173	9.999+	2.765
90	7	S15	0	31.918	2640.538	838.934	2640.538	9.999+	3.147
91	8	S1	0	5.959	2237.721	629.539	2237.721	9.999+	3.555
92	8	S2	0	1.963	2244.352	704.005	2244.352	9.999+	3.188
93	8	S3	0	.833	2244.141	648.249	2244.141	9.999+	3.462
94	8	S4	0	4.39	2245.35	706.742	2245.35	9.999+	3.177
95	8	S5	0	4.582	2240.695	656.968	2240.695	9.999+	3.411
96	8	S6	0	5.581	2241.373	663.561	2241.373	9.999+	3.378
97	8	S7	0	3.153	2245.542	704.486	2245.542	9.999+	3.187
98	8	S8	0	0	2243.59	646.38	2243.59	9.999+	3.471
99	8	S9	0	3.076	2245.543	704.499	2245.543	9.999+	3.187
100	8	S10	0	5.504	2241.372	663.559	2241.372	9.999+	3.378
101	8	S11	0	4.661	2240.699	656.996	2240.699	9.999+	3.411
102	8	S12	0	4.456	2245.342	706.679	2245.342	9.999+	3.177
103	8	S13	0	.686	2244.156	648.274	2244.156	9.999+	3.462
104	8	S14	0	2.071	2244.386	704.176	2244.386	9.999+	3.187
105	8	S15	0	6.333	2237.709	629.421	2237.709	9.999+	3.555
106	9	S1	0	16.914	2285.405	525.584	2285.405	9.999+	4.348
107	9	S2	0	5.372	2305.462	602.663	2305.462	9.999+	3.825
108	9	S3	0	.462	2299.426	534.746	2299.426	9.999+	4.3
109	9	S4	0	8.44	2301.816	606.869	2301.816	9.999+	3.793
110	9	S5	0	7.697	2294.773	546.402	2294.773	9.999+	4.2
111	9	S6	0	9.318	2295.811	554.539	2295.811	9.999+	4.14
112	9	S7	0	6.089	2301.958	604.008	2301.958	9.999+	3.811
113	9	S8	0	0	2299.434	532.701	2299.434	9.999+	4.317
114	9	S9	0	6.036	2301.958	604.019	2301.958	9.999+	3.811
115	9	S10	0	9.265	2295.81	554.539	2295.81	9.999+	4.14
116	9	S11	0	7.75	2294.776	546.416	2294.776	9.999+	4.2
117	9	S12	0	8.443	2301.811	606.862	2301.811	9.999+	3.793
118	9	S13	0	0	2299.448	534.739	2299.448	9.999+	4.3
119	9	S14	0	5.374	2305.406	602.784	2305.406	9.999+	3.825
120	9	S15	0	17.216	2285.462	525.502	2285.462	9.999+	4.349
121	10	S1	0	20.399	2971.471	734.462	2971.471	9.999+	4.046
122	10	S2	0	11.451	2994.965	821.34	2994.965	9.999+	3.646
123	10	S3	0	.972	3009.519	756.29	3009.519	9.999+	3.979
124	10	S4	0	18.706	3012.03	824.532	3012.03	9.999+	3.653
125	10	S5	0	11.891	2992.42	766.463	2992.42	9.999+	3.904
126	10	S6	0	14.561	2994.88	774.155	2994.88	9.999+	3.869
127	10	S7	0	15.85	3013.424	821.901	3013.424	9.999+	3.666
128	10	S8	0	0	3005.962	754.11	3005.962	9.999+	3.986



Company : Vector Structural Engineering
 Designer : STB
 Job Number : U2716.0319.211
 Model Name : Ground Mount

Aug 16, 2021
 4:11 PM
 Checked By: _____

Slab Sliding Safety Factors (Continued)

LC	Slab	Angle[deg]	Va-xx[lb]	Vr-xx[lb]	Va-zz[lb]	Vr-zz[lb]	SR-xx	SR-zz	
129	10	S9	0	15.93	3013.423	821.915	3013.423	9.999+	3.666
130	10	S10	0	14.64	2994.883	774.152	2994.883	9.999+	3.869
131	10	S11	0	11.807	2992.419	766.496	2992.419	9.999+	3.904
132	10	S12	0	18.644	3012.053	824.459	3012.053	9.999+	3.653
133	10	S13	0	.801	3009.447	756.319	3009.447	9.999+	3.979
134	10	S14	0	11.387	2995.048	821.538	2995.048	9.999+	3.646
135	10	S15	0	20.827	2971.411	734.324	2971.411	9.999+	4.046
136	11	S1	0	28.746	2921.498	629.305	2921.498	9.999+	4.642
137	11	S2	0	8.906	2933.972	715.68	2933.972	9.999+	4.1
138	11	S3	0	.646	2952.953	642.838	2952.953	9.999+	4.594
139	11	S4	0	15.493	2954.496	719.953	2954.496	9.999+	4.104
140	11	S5	0	9.28	2937.038	655.057	2937.038	9.999+	4.484
141	11	S6	0	11.425	2939.182	663.756	2939.182	9.999+	4.428
142	11	S7	0	13.296	2955.911	716.916	2955.911	9.999+	4.123
143	11	S8	0	0	2948.995	640.581	2948.995	9.999+	4.604
144	11	S9	0	13.353	2955.91	716.929	2955.91	9.999+	4.123
145	11	S10	0	11.482	2939.185	663.755	2939.185	9.999+	4.428
146	11	S11	0	9.22	2937.039	655.078	2937.039	9.999+	4.483
147	11	S12	0	15.444	2954.516	719.927	2954.516	9.999+	4.104
148	11	S13	0	.536	2952.875	642.84	2952.875	9.999+	4.593
149	11	S14	0	8.925	2934.126	715.834	2934.126	9.999+	4.099
150	11	S15	0	29.103	2921.383	629.201	2921.383	9.999+	4.643
151	12	S1	0	15.39	856.757	839.385	856.757	9.999+	1.021
152	12	S2	0	5.155	846.952	938.674	846.952	9.999+	.902
153	12	S3	0	1.11	838.417	864.332	838.417	9.999+	.97
154	12	S4	0	7.8	837.847	942.322	837.847	9.999+	.889
155	12	S5	0	3.767	845.752	875.958	845.752	9.999+	.966
156	12	S6	0	4.636	844.825	884.749	844.825	9.999+	.955
157	12	S7	0	6.986	837.186	939.315	837.186	9.999+	.891
158	12	S8	0	0	840.074	861.84	840.074	9.999+	.975
159	12	S9	0	7.082	837.186	939.332	837.186	9.999+	.891
160	12	S10	0	4.731	844.822	884.745	844.822	9.999+	.955
161	12	S11	0	3.668	845.755	875.995	845.755	9.999+	.965
162	12	S12	0	7.721	837.829	942.238	837.829	9.999+	.889
163	12	S13	0	.915	838.467	864.365	838.467	9.999+	.97
164	12	S14	0	5.047	846.933	938.901	846.933	9.999+	.902
165	12	S15	0	15.884	856.78	839.228	856.78	9.999+	1.021
166	13	S1	0	29.997	920.335	700.779	920.335	9.999+	1.313
167	13	S2	0	.61	928.432	803.55	928.432	9.999+	1.155
168	13	S3	0	.616	912.129	712.994	912.129	9.999+	1.279
169	13	S4	0	2.401	913.135	809.158	913.135	9.999+	1.129
170	13	S5	0	.386	917.856	728.535	917.856	9.999+	1.26
171	13	S6	0	.346	917.409	739.386	917.409	9.999+	1.241
172	13	S7	0	3.071	912.406	805.344	912.406	9.999+	1.133
173	13	S8	0	0	914.533	710.267	914.533	9.999+	1.288
174	13	S9	0	3.135	912.407	805.359	912.407	9.999+	1.133
175	13	S10	0	.282	917.406	739.386	917.406	9.999+	1.241
176	13	S11	0	.45	917.858	728.555	917.858	9.999+	1.26
177	13	S12	0	2.404	913.122	809.149	913.122	9.999+	1.128
178	13	S13	0	0	912.19	712.985	912.19	9.999+	1.279
179	13	S14	0	.643	928.293	803.713	928.293	9.999+	1.155
180	13	S15	0	30.395	920.452	700.669	920.452	9.999+	1.314
181	14	S1	0	19.753	1835.09	979.282	1835.09	9.999+	1.874
182	14	S2	0	7.495	1847.769	1095.119	1847.769	9.999+	1.687
183	14	S3	0	1.295	1858.92	1008.387	1858.92	9.999+	1.843
184	14	S4	0	11.288	1860.087	1099.376	1860.087	9.999+	1.692
185	14	S5	0	5.978	1848.052	1021.951	1848.052	9.999+	1.808



Company:		Date:	5/14/2018
Engineer:		Page:	1/6
Project:			
Address:			
Phone:			
E-mail:			

1. Project information

Customer company:
Customer contact name:
Customer e-mail:
Comment:

Project description:
Location:
Fastening description:

2. Input Data & Anchor Parameters

General

Design method: ACI 318-14
Units: Imperial units

Anchor Information:

Anchor type: Bonded anchor
Material: F1554 Grade 36
Diameter (inch): 0.375
Effective Embedment depth, h_{ef} (inch): 4.000
Code report: ICC-ES ESR-4057
Anchor category: -
Anchor ductility: Yes
 h_{min} (inch): 5.25
 c_{ac} (inch): 7.12
 C_{min} (inch): 1.75
 S_{min} (inch): 1.00

Base Material

Concrete: Normal-weight
Concrete thickness, h (inch): 24.00
State: Cracked
Compressive strength, f'_c (psi): 2500
 $\Psi_{c,v}$: 1.0
Reinforcement condition: B tension, B shear
Supplemental reinforcement: Not applicable
Reinforcement provided at corners: No
Ignore concrete breakout in tension: No
Ignore concrete breakout in shear: No
Hole condition: Dry concrete
Inspection: Periodic
Temperature range, Short/Long: 150/110°F
Ignore 6do requirement: Not applicable
Build-up grout pad: No

Base Plate

Length x Width x Thickness (inch): 4.75 x 4.75 x 0.31

Recommended Anchor

Anchor Name: SET-3G - SET-3G w/ 3/8"Ø F1554 Gr. 36
Code Report: ICC-ES ESR-4057





Company:		Date:	5/14/2018
Engineer:		Page:	2/6
Project:			
Address:			
Phone:			
E-mail:			

Load and Geometry

Load factor source: ACI 318 Section 5.3

Load combination: not set

Seismic design: No

Anchors subjected to sustained tension: No

Apply entire shear load at front row: No

Anchors only resisting wind and/or seismic loads: No

Strength level loads:

N_{ua} [lb]: 3072

V_{uax} [lb]: 1846

V_{uay} [lb]: -1924

M_{ux} [ft-lb]: 0

M_{uy} [ft-lb]: 0

M_{uz} [ft-lb]: 0

<Figure 1>

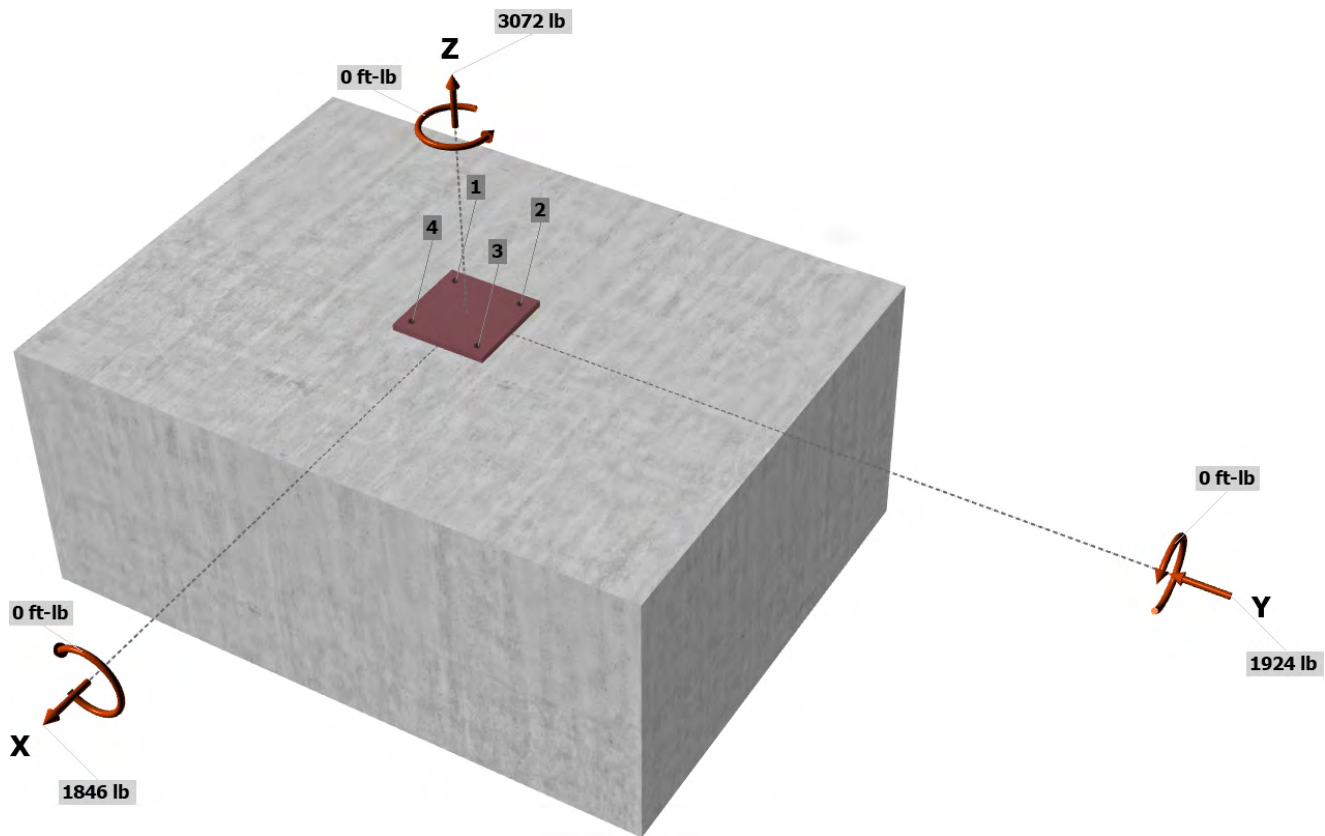



Company:		Date:	5/14/2018
Engineer:		Page:	4/6
Project:			
Address:			
Phone:			
E-mail:			

3. Resulting Anchor Forces

Anchor	Tension load, N _{ua} (lb)	Shear load x, V _{uax} (lb)	Shear load y, V _{uay} (lb)	Shear load combined, $\sqrt{(V_{uax})^2 + (V_{uay})^2}$ (lb)
1	768.0	461.5	-481.0	666.6
2	768.0	461.5	-481.0	666.6
3	768.0	461.5	-481.0	666.6
4	768.0	461.5	-481.0	666.6
Sum	3072.0	1846.0	-1924.0	2666.4

Maximum concrete compression strain (%): 0.00
 Maximum concrete compression stress (psi): 0
 Resultant tension force (lb): 3072
 Resultant compression force (lb): 0
 Eccentricity of resultant tension forces in x-axis, e'_{Nx} (inch): 0.00
 Eccentricity of resultant tension forces in y-axis, e'_{Ny} (inch): 0.00
 Eccentricity of resultant shear forces in x-axis, e'_{Vx} (inch): 0.00
 Eccentricity of resultant shear forces in y-axis, e'_{Vy} (inch): 0.00

<Figure 3>

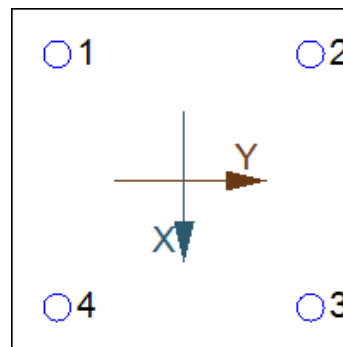

4. Steel Strength of Anchor in Tension (Sec. 17.4.1)

N _{sa} (lb)	φ	φN _{sa} (lb)
4525	0.75	3394

5. Concrete Breakout Strength of Anchor in Tension (Sec. 17.4.2)

$$N_b = K_c \lambda_a \sqrt{f'_c} c_{hef}^{1.5} \text{ (Eq. 17.4.2.2a)}$$

K _c	λ _a	f' _c (psi)	h _{ef} (in)	N _b (lb)
17.0	1.00	2500	4.000	6800

$$\phi N_{cbg} = \phi (A_{Nc} / A_{Nco}) \Psi_{ec,N} \Psi_{ed,N} \Psi_{c,N} \Psi_{cp,N} N_b \text{ (Sec. 17.3.1 \& Eq. 17.4.2.1b)}$$

A _{Nc} (in ²)	A _{Nco} (in ²)	C _{a,min} (in)	Ψ _{ec,N}	Ψ _{ed,N}	Ψ _{c,N}	Ψ _{cp,N}	N _b (lb)	φ	φN _{cbg} (lb)
240.25	144.00	10.25	1.000	1.000	1.00	1.000	6800	0.65	7374

6. Adhesive Strength of Anchor in Tension (Sec. 17.4.5)

$$\tau_{k,cr} = \tau_{k,cr,short-term} K_{sat} (f'_c / 2,500)^0$$

τ _{k,cr} (psi)	f _{short-term}	K _{sat}	f' _c (psi)	n	τ _{k,cr} (psi)
1346	1.00	1.00	2500	0.24	1346

$$N_{ba} = \lambda_a \tau_{cr} \pi d_a h_{ef} \text{ (Eq. 17.4.5.2)}$$

λ _a	τ _{cr} (psi)	d _a (in)	h _{ef} (in)	N _{ba} (lb)
1.00	1346	0.38	4.000	6343

$$\phi N_{ag} = \phi (A_{Na} / A_{Na0}) \Psi_{ec,Na} \Psi_{ed,Na} \Psi_{cp,Na} N_{ba} \text{ (Sec. 17.3.1 \& Eq. 17.4.5.1b)}$$

A _{Na} (in ²)	A _{Na0} (in ²)	C _{Na} (in)	C _{a,min} (in)	Ψ _{ec,Na}	Ψ _{ed,Na}	Ψ _{cp,Na}	N _{ba} (lb)	φ	φN _{ag} (lb)
198.45	112.09	5.29	10.25	1.000	1.000	1.000	6343	0.55	6176



Company:		Date:	5/14/2018
Engineer:		Page:	5/6
Project:			
Address:			
Phone:			
E-mail:			

8. Steel Strength of Anchor in Shear (Sec. 17.5.1)

V_{sa} (lb)	ϕ_{grout}	ϕ	$\phi_{grout}\phi V_{sa}$ (lb)
2715	1.0	0.65	1765

9. Concrete Breakout Strength of Anchor in Shear (Sec. 17.5.2)

Shear perpendicular to edge in x-direction:

$V_{bx} = \min|7(l_e / d_a)^{0.2} \sqrt{d_a} \lambda_a \sqrt{f_c} c_{a1}^{1.5}; 9 \lambda_a \sqrt{f_c} c_{a1}^{1.5}|$ (Eq. 17.5.2.2a & Eq. 17.5.2.2b)

l_e (in)	d_a (in)	λ_a	f_c (psi)	c_{a1} (in)	V_{bx} (lb)
3.00	0.375	1.00	2500	13.75	16564

$\phi V_{cbgx} = \phi (A_{vc} / A_{vco}) \Psi_{ec,v} \Psi_{ed,v} \Psi_{c,v} \Psi_{h,v} V_{bx}$ (Sec. 17.3.1 & Eq. 17.5.2.1b)

A_{vc} (in ²)	A_{vco} (in ²)	$\Psi_{ec,v}$	$\Psi_{ed,v}$	$\Psi_{c,v}$	$\Psi_{h,v}$	V_{bx} (lb)	ϕ	ϕV_{cbgx} (lb)
660.00	850.78	1.000	0.907	1.000	1.000	16564	0.70	8161

Shear perpendicular to edge in y-direction:

$V_{by} = \min|7(l_e / d_a)^{0.2} \sqrt{d_a} \lambda_a \sqrt{f_c} c_{a1}^{1.5}; 9 \lambda_a \sqrt{f_c} c_{a1}^{1.5}|$ (Eq. 17.5.2.2a & Eq. 17.5.2.2b)

l_e (in)	d_a (in)	λ_a	f_c (psi)	c_{a1} (in)	V_{by} (lb)
3.00	0.375	1.00	2500	16.00	20791

$\phi V_{cbgy} = \phi (A_{vc} / A_{vco}) \Psi_{ec,v} \Psi_{ed,v} \Psi_{c,v} \Psi_{h,v} V_{by}$ (Sec. 17.3.1 & Eq. 17.5.2.1b)

A_{vc} (in ²)	A_{vco} (in ²)	$\Psi_{ec,v}$	$\Psi_{ed,v}$	$\Psi_{c,v}$	$\Psi_{h,v}$	V_{by} (lb)	ϕ	ϕV_{cbgy} (lb)
576.00	1152.00	1.000	0.828	1.000	1.000	20791	0.70	6026

Shear parallel to edge in y-direction:

$V_{bx} = \min|7(l_e / d_a)^{0.2} \sqrt{d_a} \lambda_a \sqrt{f_c} c_{a1}^{1.5}; 9 \lambda_a \sqrt{f_c} c_{a1}^{1.5}|$ (Eq. 17.5.2.2a & Eq. 17.5.2.2b)

l_e (in)	d_a (in)	λ_a	f_c (psi)	c_{a1} (in)	V_{bx} (lb)
3.00	0.375	1.00	2500	14.25	17475

$\phi V_{cbgy} = \phi (2)(A_{vc} / A_{vco}) \Psi_{ec,v} \Psi_{ed,v} \Psi_{c,v} \Psi_{h,v} V_{bx}$ (Sec. 17.3.1, 17.5.2.1(c) & Eq. 17.5.2.1b)

A_{vc} (in ²)	A_{vco} (in ²)	$\Psi_{ec,v}$	$\Psi_{ed,v}$	$\Psi_{c,v}$	$\Psi_{h,v}$	V_{bx} (lb)	ϕ	ϕV_{cbgy} (lb)
513.00	913.78	1.000	1.000	1.000	1.000	17475	0.70	13735

Shear parallel to edge in x-direction:

$V_{by} = \min|7(l_e / d_a)^{0.2} \sqrt{d_a} \lambda_a \sqrt{f_c} c_{a1}^{1.5}; 9 \lambda_a \sqrt{f_c} c_{a1}^{1.5}|$ (Eq. 17.5.2.2a & Eq. 17.5.2.2b)

l_e (in)	d_a (in)	λ_a	f_c (psi)	c_{a1} (in)	V_{by} (lb)
3.00	0.375	1.00	2500	10.25	10661

$\phi V_{cbgx} = \phi (2)(A_{vc} / A_{vco}) \Psi_{ec,v} \Psi_{ed,v} \Psi_{c,v} \Psi_{h,v} V_{by}$ (Sec. 17.3.1, 17.5.2.1(c) & Eq. 17.5.2.1b)

A_{vc} (in ²)	A_{vco} (in ²)	$\Psi_{ec,v}$	$\Psi_{ed,v}$	$\Psi_{c,v}$	$\Psi_{h,v}$	V_{by} (lb)	ϕ	ϕV_{cbgx} (lb)
492.00	472.78	1.000	1.000	1.000	1.000	10661	0.70	15532

10. Concrete Pryout Strength of Anchor in Shear (Sec. 17.5.3)

$\phi V_{cp} = \phi \min|k_{cp} N_{ba}; k_{cp} N_{cb}| = \phi \min|k_{cp} (A_{Na} / A_{Na0}) \Psi_{ec,Na} \Psi_{ed,Na} \Psi_{cp,Na} N_{ba}; k_{cp} (A_{Nc} / A_{Nco}) \Psi_{ec,N} \Psi_{ed,N} \Psi_{cp,N} N_{cb}|$ (Sec. 17.3.1 & Eq. 17.5.3.1b)

k_{cp}	A_{Na} (in ²)	A_{Na0} (in ²)	$\Psi_{ed,Na}$	$\Psi_{ec,Na}$	$\Psi_{cp,Na}$	N_{ba} (lb)	N_a (lb)
2.0	198.45	112.09	1.000	1.000	1.000	6343	11230

A_{Nc} (in ²)	A_{Nco} (in ²)	$\Psi_{ec,N}$	$\Psi_{ed,N}$	$\Psi_{c,N}$	$\Psi_{cp,N}$	N_b (lb)	N_{cb} (lb)	ϕ
240.25	144.00	1.000	1.000	1.000	1.000	6800	11345	0.70



Company:		Date:	5/14/2018
Engineer:		Page:	6/6
Project:			
Address:			
Phone:			
E-mail:			

ϕV_{cpg} (lb)
15722

11. Results

Interaction of Tensile and Shear Forces (Sec. R17.6)

Tension	Factored Load, N_{ua} (lb)	Design Strength, ϕN_n (lb)	Ratio	Status	
Steel	768	3394	0.23	Pass	
Concrete breakout	3072	7374	0.42	Pass	
Adhesive	3072	6176	0.50	Pass (Governs)	
Shear	Factored Load, V_{ua} (lb)	Design Strength, ϕV_n (lb)	Ratio	Status	
Steel	667	1765	0.38	Pass	
T Concrete breakout x+	1846	8161	0.23	Pass	
T Concrete breakout y-	1924	6026	0.32	Pass	
Concrete breakout y-	923	13735	0.07	Pass	
Concrete breakout x-	962	15532	0.06	Pass	
Concrete breakout, combined	-	-	0.39	Pass (Governs)	
Pryout	2666	15722	0.17	Pass	
Interaction check	$(N_{ua}/\phi N_{ua})^{5/3}$	$(V_{ua}/\phi V_{ua})^{5/3}$	Combined Ratio	Permissible	Status
Sec. R17.6	0.31	0.21	52.2%	1.0	Pass

SET-3G w/ 3/8"Ø F1554 Gr. 36 with hef = 4.000 inch meets the selected design criteria.

12. Warnings

- Designer must exercise own judgement to determine if this design is suitable.
- Refer to manufacturer's product literature for hole cleaning and installation instructions.

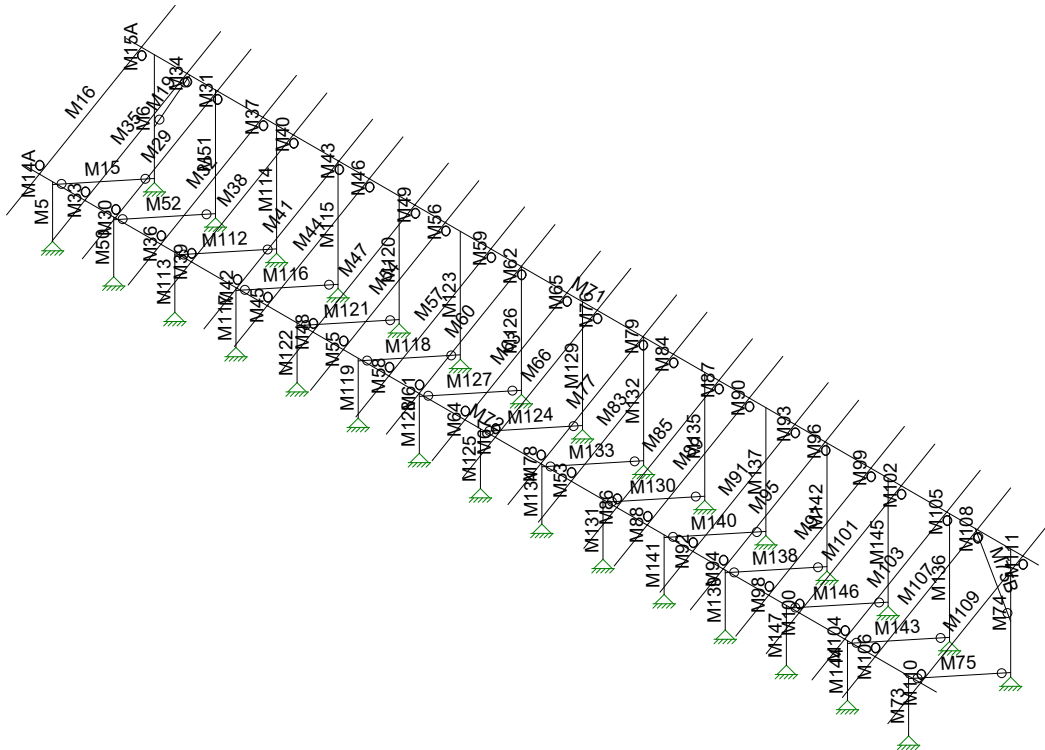

Envelope Only Solution

Vector Structural Engineeri...

MIH

U2716.0319.211

Sunturf Ground Mount B6 (82x42)

SK - 1

Aug 16, 2021 at 4:22 PM

Sunturf Ground Mount B6 82x42.r3d

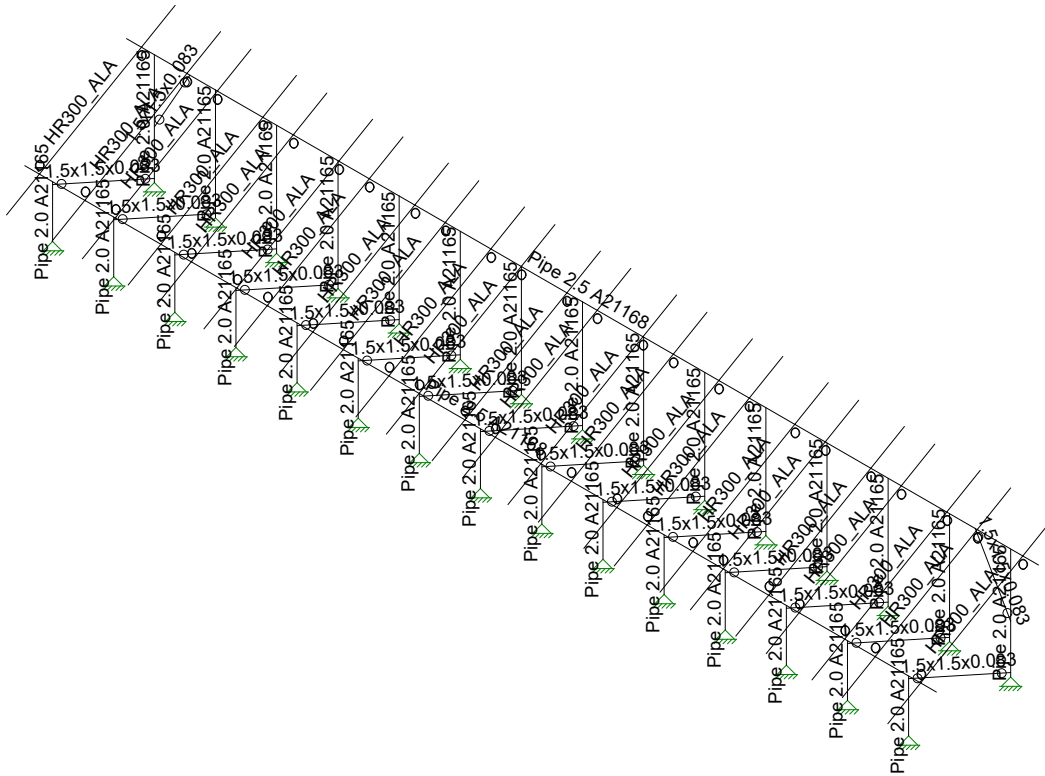

Envelope Only Solution

Vector Structural Engineeri...

MIH

U2716.0319.211

Sunturf Ground Mount B6 (82x42)

SK - 2

Aug 16, 2021 at 4:23 PM

Sunturf Ground Mount B6 82x42.r3d

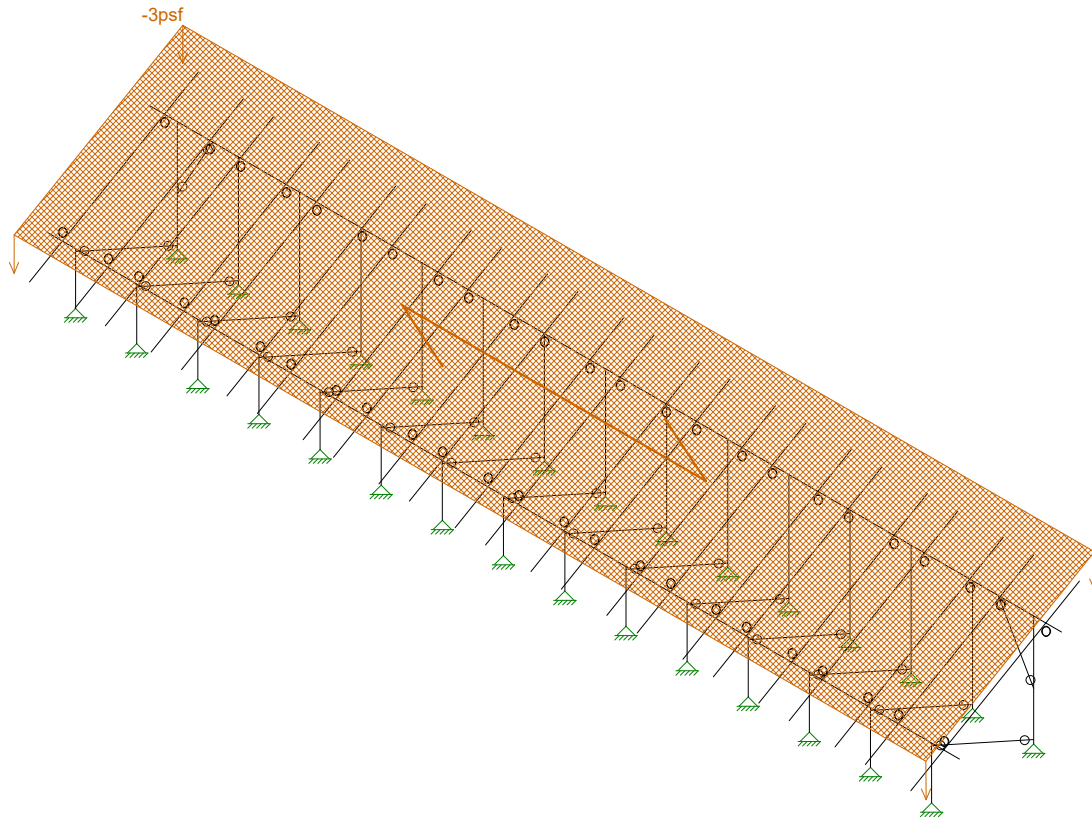

Loads: BLC 2, Solar Panel Weight
Envelope Only Solution

Vector Structural Engineeri...	Sunturf Ground Mount B6 (82x42)	SK - 3
MIH		Aug 16, 2021 at 4:23 PM
U2716.0319.211		Sunturf Ground Mount B6 82x42.r3d

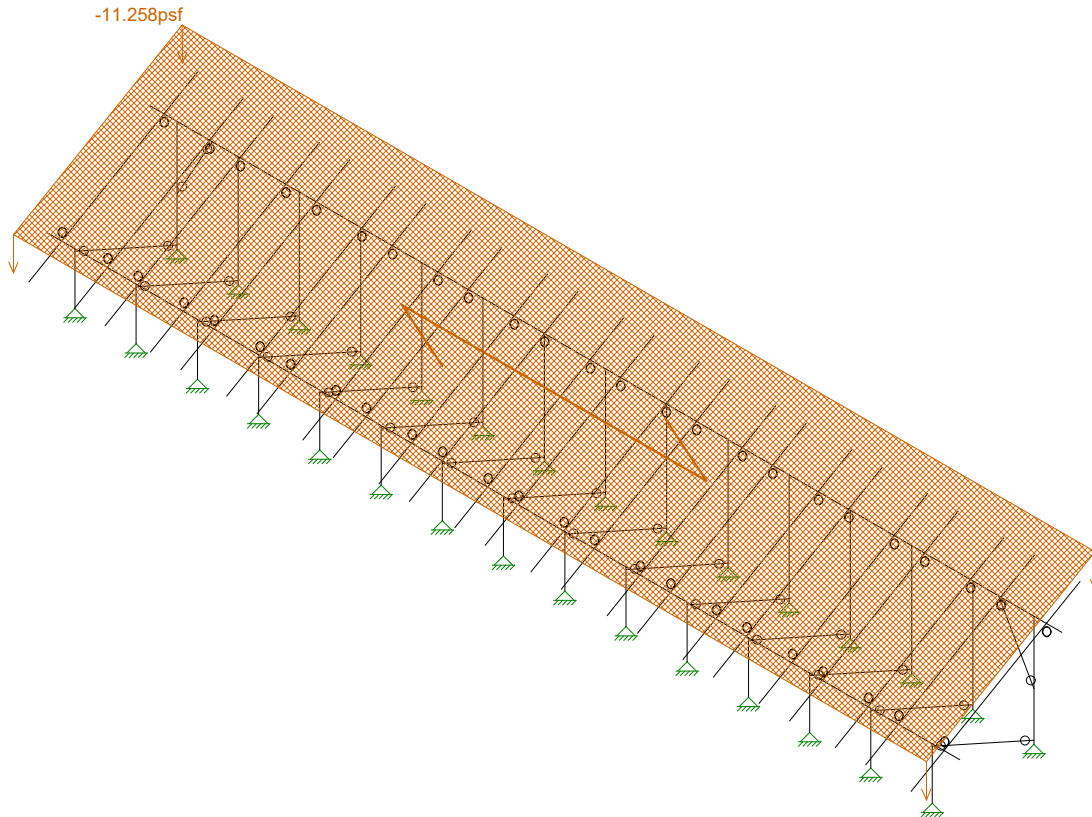

Loads: BLC 3, Roof Live/Snow

Vector Structural Engineeri...	Sunturf Ground Mount B6 (82x42)	SK - 1
MIH		Aug 16, 2021 at 5:07 PM
U2716.0319.211		Sunturf Ground Mount B6 82x42.r3d

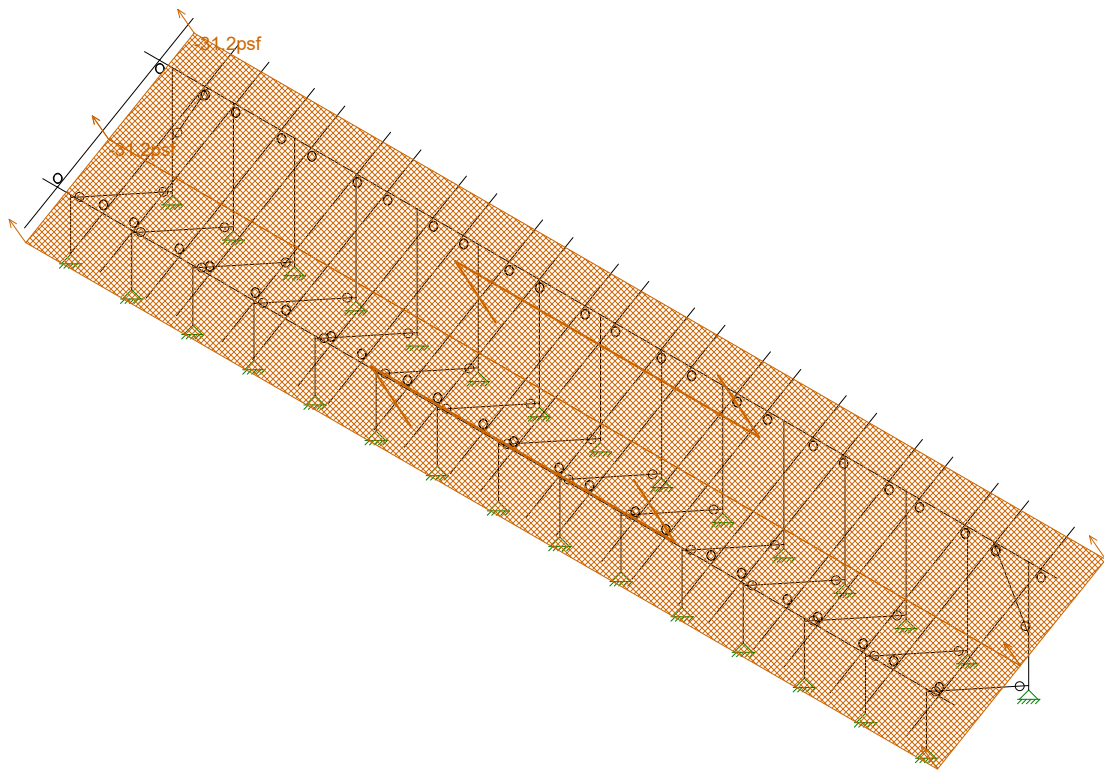

Loads: BLC 4, Wind A 0 deg
Envelope Only Solution

Vector Structural Engineeri...
MIH
U2716.0319.211

Sunturf Ground Mount B6 (82x42)

SK - 5

Aug 16, 2021 at 4:23 PM

Sunturf Ground Mount B6 82x42.r3d

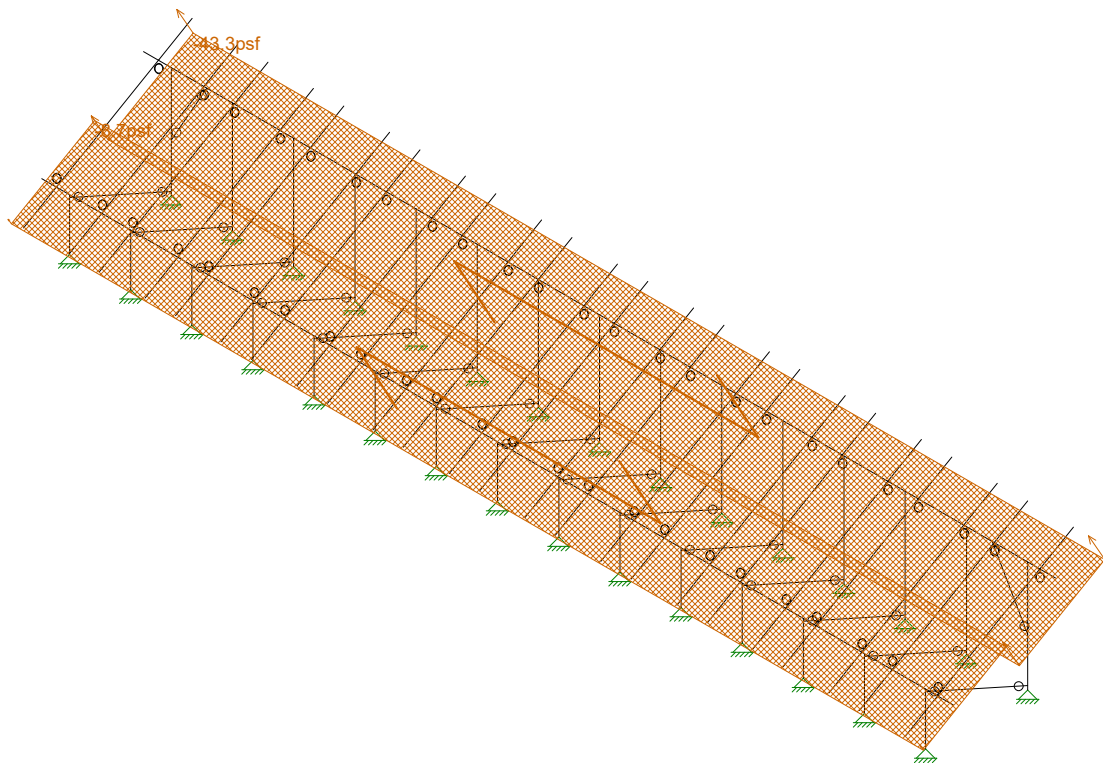

Loads: BLC 5, Wind B 0 deg
Envelope Only Solution

Vector Structural Engineeri...
MIH
U2716.0319.211

Sunturf Ground Mount B6 (82x42)

SK - 6

Aug 16, 2021 at 4:23 PM

Sunturf Ground Mount B6 82x42.r3d

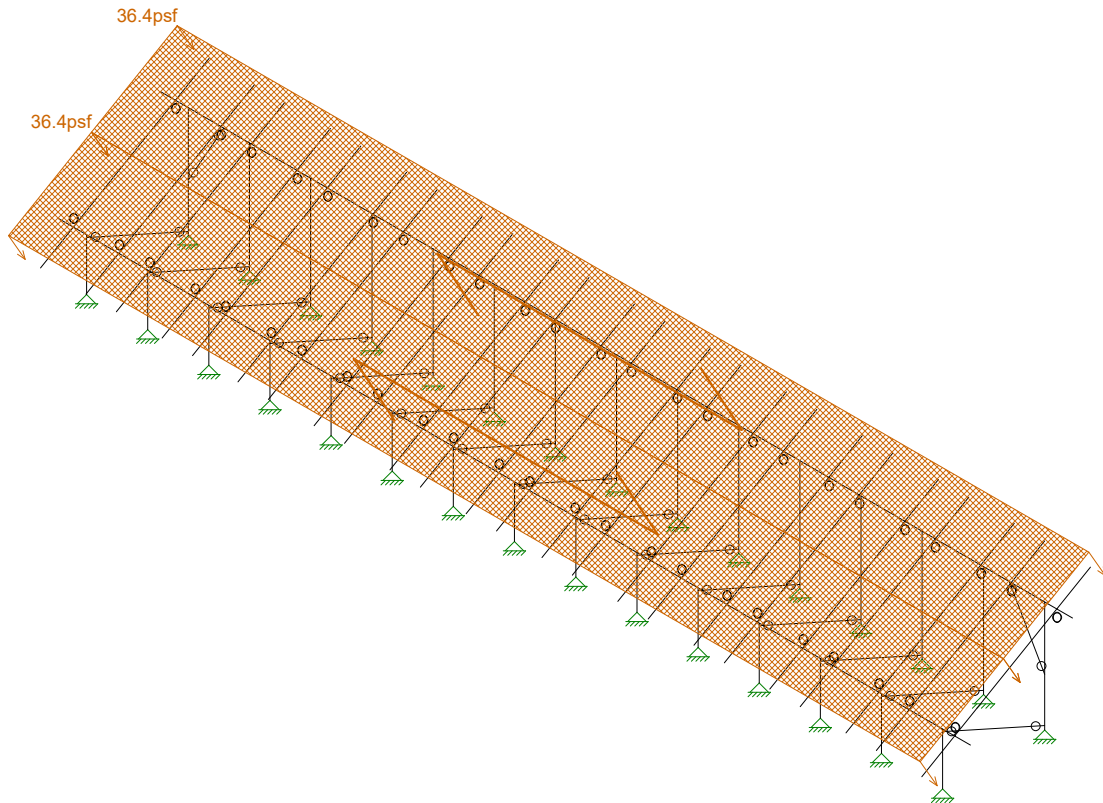

Loads: BLC 6, Wind A 180 deg
Envelope Only Solution

Vector Structural Engineeri...
MIH
U2716.0319.211

Sunturf Ground Mount B6 (82x42)

SK - 7

Aug 16, 2021 at 4:23 PM

Sunturf Ground Mount B6 82x42.r3d

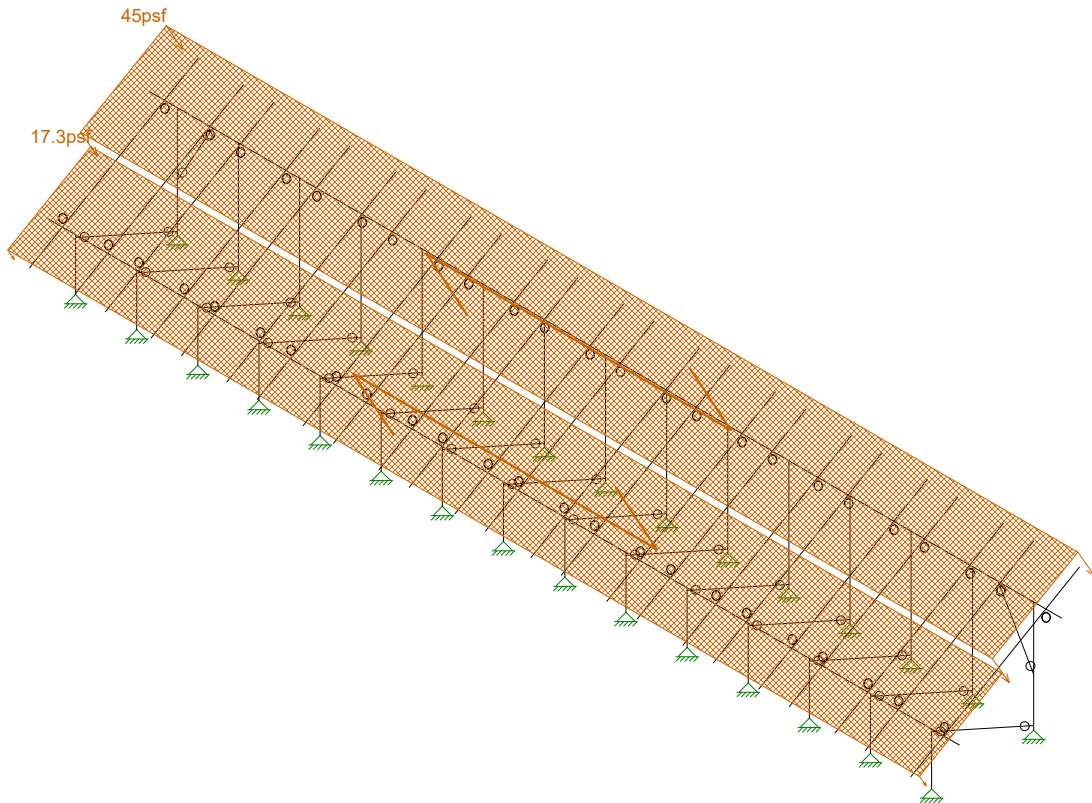

Loads: BLC 7, Wind B 180 deg
Envelope Only Solution

Vector Structural Engineeri...
MIH
U2716.0319.211

Sunturf Ground Mount B6 (82x42)

SK - 8

Aug 16, 2021 at 4:24 PM

Sunturf Ground Mount B6 82x42.r3d



(Global) Model Settings

Display Sections for Member Calcs	5
Max Internal Sections for Member Calcs	97
Include Shear Deformation?	Yes
Increase Nailing Capacity for Wind?	Yes
Include Warping?	Yes
Trans Load Btwn Intersecting Wood Wall?	Yes
Area Load Mesh (in^2)	144
Merge Tolerance (in)	.12
P-Delta Analysis Tolerance	0.50%
Include P-Delta for Walls?	Yes
Automatically Iterate Stiffness for Walls?	Yes
Max Iterations for Wall Stiffness	3
Gravity Acceleration (in/sec^2)	386.4
Wall Mesh Size (in)	24
Eigensolution Convergence Tol. (1.E-)	4
Vertical Axis	Y
Global Member Orientation Plane	XZ
Static Solver	Sparse Accelerated
Dynamic Solver	Accelerated Solver

Hot Rolled Steel Code	AISC 14th(360-10): ASD
Adjust Stiffness?	Yes(Iterative)
RISACONNECTION CODE	AISC 14th(360-10): ASD
Cold Formed Steel Code	AISI S100-12: ASD
Wood Code	AWC NDS-15: ASD
Wood Temperature	< 100F
Concrete Code	ACI 318-14
Masonry Code	ACI 530-13: ASD
Aluminum Code	AA ADM1-15: ASD - Building
Stainless Steel Code	AISC 14th(360-10): ASD
Adjust Stiffness?	Yes(Iterative)

Number of Shear Regions	4
Region Spacing Increment (in)	4
Biaxial Column Method	Exact Integration
Parame Beta Factor (PCA)	.65
Concrete Stress Block	Rectangular
Use Cracked Sections?	No
Use Cracked Sections Slab?	No
Bad Framing Warnings?	No
Unused Force Warnings?	Yes
Min 1 Bar Diam. Spacing?	No
Concrete Rebar Set	REBAR SET ASTMA615
Min % Steel for Column	1
Max % Steel for Column	8

(Global) Model Settings, Continued

Seismic Code	ASCE 7-10
Seismic Base Elevation (in)	15600
Add Base Weight?	Yes
Ct X	.02
Ct Z	.02
T X (sec)	Not Entered
T Z (sec)	Not Entered
R X	3
R Z	3
Ct Exp. X	.75
Ct Exp. Z	.75
SD1	1
SDS	1
S1	1
TL (sec)	5
Risk Cat	I or II
Drift Cat	Other
Om Z	1
Om X	1
Cd Z	4
Cd X	4
Rho Z	1
Rho X	1

Hot Rolled Steel Properties

	Label	E [ksi]	G [ksi]	Nu	Therm (/1E5 F)	Density[lb/ft^3]	Yield[psi]	Ry	Fu[psi]	Rt
1	A992	29000	11154	.3	.65	490	50000	1.1	65000	1.1
2	A36 Gr.36	29000	11154	.3	.65	490	36000	1.5	58000	1.2
3	A572 Gr.50	29000	11154	.3	.65	490	50000	1.1	65000	1.1
4	A500 Gr.B R...	29000	11154	.3	.65	527	42000	1.4	58000	1.3
5	A500 Gr.B Re...	29000	11154	.3	.65	527	46000	1.4	58000	1.3
6	A53 Gr.B	29000	11154	.3	.65	490	35000	1.6	60000	1.2
7	A1085	29000	11154	.3	.65	490	50000	1.4	65000	1.3

Aluminum Properties

	Label	E [ksi]	G [ksi]	Nu	Therm (...Density[... Table B.4	kt	Ftu[psi]	Fty[psi]	Fcy[psi]	Fsu[psi]	Ct
1	3003-H14	10100	3787.5	.33	1.3 172.8 Table B.4-1	1	19000	16000	13000	12000	141
2	6061-T6	10100	3787.5	.33	1.3 172.8 Table B.4-2	1	38000	35000	35000	24000	141
3	6063-T5	10100	3787.5	.33	1.3 172.8 Table B.4-2	1	22000	16000	16000	13000	141
4	6063-T6	10100	3787.5	.33	1.3 172.8 Table B.4-2	1	30000	25000	25000	19000	141
5	5052-H34	10200	3787.5	.33	1.3 172.8 Table B.4-1	1	34000	26000	24000	20000	141
6	6061-T6 W	10100	3787.5	.33	1.3 172.8 Table B.4-1	1	24000	15000	15000	15000	141
7	6005-T5	10100	3787.5	.33	1.3 172.8 Table B.4-1	1	38000	35000	35000	24000	141

Hot Rolled Steel Section Sets

	Label	Shape	Type	Design List	Material	Design R...	A [in2]	Iyy [in4]	Izz [in4]	J [in4]
1	Post	Pipe 2.0 A21165	Column	Pipe	A572 Gr.50	Typical	.776	.499	.499	.998
2	Cross Beam	Pipe 2.5 A21168	Beam	Wide Flange	A572 Gr.50	Typical	.947	.907	.907	1.814
3	Diagonal Brace	1.5x1.5x0.083	HBrace	SquareTube	A572 Gr.50	Typical	.47	.158	.158	.236



Aluminum Section Sets

	Label	Shape	Type	Design List	Material	Design R...	A [in2]	Iyy [in4]	Izz [in4]	J [in4]
1	AL Posts	2.375ODX0.188	Column	Pipe	6005-T5	Typical	1.29	.778	.778	1.54
2	AL Brace	RT1.5x2x0.15625	VBrace	Rectangular Tubes	6005-T5	Typical	.996	.327	.524	.602
3	AL Rails	HR300 ALA	Beam	Rectangular Tubes	6005-T5	Typical	.736	.214	.727	.734
4	AL Cross Beam	Cross Rail	Beam	Rectangular Tubes	6005-T5	Typical	1.909	1.97	4.366	4.017

Member Area Loads (BLC 2 : Solar Panel Weight)

	Joint A	Joint B	Joint C	Joint D	Direction	Distribution	Magnitude[psf]
1	N197	N200	N199	N196	Y	A-B	-3

Member Area Loads (BLC 3 : Roof Live/Snow)

	Joint A	Joint B	Joint C	Joint D	Direction	Distribution	Magnitude[psf]
1	N197	N200	N199	N196	PY	A-B	-13

Member Area Loads (BLC 4 : Wind A 0 deg)

	Joint A	Joint B	Joint C	Joint D	Direction	Distribution	Magnitude[psf]
1	N197	N200	N201	N198	Perp	A-B	-31.2
2	N198	N201	N199	N196	Perp	A-B	-31.2

Member Area Loads (BLC 5 : Wind B 0 deg)

	Joint A	Joint B	Joint C	Joint D	Direction	Distribution	Magnitude[psf]
1	N197	N200	N201	N198	Perp	A-B	-43.3
2	N198	N201	N199	N196	Perp	A-B	-8.7

Member Area Loads (BLC 6 : Wind A 180 deg)

	Joint A	Joint B	Joint C	Joint D	Direction	Distribution	Magnitude[psf]
1	N197	N200	N201	N198	Perp	A-B	36.4
2	N198	N201	N199	N196	Perp	A-B	36.4

Member Area Loads (BLC 7 : Wind B 180 deg)

	Joint A	Joint B	Joint C	Joint D	Direction	Distribution	Magnitude[psf]
1	N197	N200	N201	N198	Perp	A-B	45
2	N198	N201	N199	N196	Perp	A-B	17.3

Basic Load Cases

	BLC Description	Category	X Gravity	Y Gravity	Z Gravity	Joint	Point	Distributed	Area(M...Surface...
1	Self Weight	DL		-1.05					
2	Solar Panel Weight	DL							1
3	Roof Live/Snow	RLL							1
4	Wind A 0 deg	OL1							2
5	Wind B 0 deg	OL2							2
6	Wind A 180 deg	OL3							2
7	Wind B 180 deg	OL4							2
8	BLC 2 Transient Area ...	None						52	
9	BLC 3 Transient Area ...	None						52	
10	BLC 4 Transient Area ...	None						160	
11	BLC 5 Transient Area ...	None						160	
12	BLC 6 Transient Area ...	None						160	
13	BLC 7 Transient Area ...	None						160	



Company : Vector Structural Engineering
 Designer : MIH
 Job Number : U2716.0319.211
 Model Name : Sunturf Ground Mount B6 (82x42)

Aug 16, 2021
 5:32 PM
 Checked By: _____

Envelope Joint Reactions (Continued)

Joint	X [lb]	LC	Y [lb]	LC	Z [lb]	LC	MX [lb-ft]	LC MY [lb-ft]	LC	MZ [lb-ft]	LC			
22	min	-7.806	9	-189.922	15	-52.957	6	0	2	0	2	0	2	
23	N253	max	3.752	7	2056.81	7	1074.7...	6	0	15	0	15	0	15
24		min	-3.007	13	-1565.994	13	-920.1...	4	0	2	0	2	0	2
25	N255	max	6.482	9	890.257	9	44.139	4	0	15	0	15	0	15
26		min	-1.228	12	-176.418	15	-52.814	6	0	2	0	2	0	2
27	N257	max	3.662	13	2073.924	7	1085.1...	6	0	15	0	15	0	15
28		min	-4.556	7	-1581.657	13	-929.0...	4	0	2	0	2	0	2
29	N260	max	4.549	7	2073.943	7	1085.1...	6	0	15	0	15	0	15
30		min	-3.66	13	-1581.669	13	-929.0...	4	0	2	0	2	0	2
31	N264	max	10.072	10	974.201	9	45.419	4	0	15	0	15	0	15
32		min	-5.059	12	-264.268	15	-53.928	6	0	2	0	2	0	2
33	N267	max	7.755	9	902.786	9	44.312	4	0	15	0	15	0	15
34		min	-1.648	12	-189.931	15	-52.957	6	0	2	0	2	0	2
35	N268	max	.054	6	885.827	9	44.259	4	0	15	0	15	0	15
36		min	-.036	13	-147.759	15	-53.062	6	0	2	0	2	0	2
37	N271	max	2.318	13	2179.436	7	1149.7...	6	0	15	0	15	0	15
38		min	-3.305	11	-1677.875	13	-984.7...	4	0	2	0	2	0	2
39	N273	max	4.989	12	974.189	9	45.419	4	0	15	0	15	0	15
40		min	-9.994	10	-264.251	15	-53.927	6	0	2	0	2	0	2
41	N275	max	.002	13	2049.907	7	1058.5...	6	0	15	0	15	0	15
42		min	-.016	4	-1558.55	13	-906.0...	4	0	2	0	2	0	2
43	N281	max	3.302	11	2179.449	7	1149.82	6	0	15	0	15	0	15
44		min	-2.316	13	-1677.887	13	-984.7...	4	0	2	0	2	0	2
45	N286	max	.844	12	885.851	9	44.175	4	0	15	0	15	0	15
46		min	-1.238	10	-146.962	15	-53.031	6	0	2	0	2	0	2
47	N289	max	5.036	12	977.963	9	45.411	4	0	15	0	15	0	15
48		min	-11.252	10	-270.263	15	-53.919	6	0	2	0	2	0	2
49	N293	max	1.831	11	2137.315	7	1151.1...	6	0	15	0	15	0	15
50		min	-1.129	13	-1630.68	13	-983.1...	4	0	2	0	2	0	2
51	N297	max	8.343	10	989.898	9	44.838	4	0	15	0	15	0	15
52		min	-3.976	12	-272.301	15	-53.624	6	0	2	0	2	0	2
53	N298	max	3.01	13	2056.775	7	1074.7...	6	0	15	0	15	0	15
54		min	-3.76	7	-1565.981	13	-920.1...	4	0	2	0	2	0	2
55	N299	max	1.152	12	890.258	9	44.139	4	0	15	0	15	0	15
56		min	-6.534	9	-176.391	15	-52.815	6	0	2	0	2	0	2
57	N301	max	3.138	13	2182.606	7	1153.3...	6	0	15	0	15	0	15
58		min	-4.308	11	-1680.727	13	-987.5...	4	0	2	0	2	0	2
59	N306	max	.051	14	2056.847	7	1059.8...	6	0	15	0	15	0	15
60		min	-.122	5	-1568.524	13	-909.0...	4	0	2	0	2	0	2
61	Totals:	max	-.001	12	38605.778	10	15669...	14						
62		min	-.007	6	-19584.815	12	-1343...	4						

Envelope AISC 14th(360-10): ASD Steel Code Checks

Member	Shape	Code Check	Loc[in]	LC	Shear	...	Loc[in]	Dir	LC	Pnc/om	[..Pnt/om	[lb]	Mnyy/om..	Mnzz/om..	Cb	Eqn
1	M5	Pipe 2.0 A2...	.170	53.493	6	.149	53.493		6	16304.154	23232.186	1397.505	1397.505	1...	H1-1b	
2	M6	Pipe 2.0 A2...	.577	3.739	6	.156	0		6	5242.145	23232.186	1397.505	1397.505	1...	H1-1a	
3	M15	1.5x1.5x0.083	.745	62.776	6	.015	120.53	y	7	1634.454	14085.15	624.421	624.421	1...	H1-1a	
4	M19	1.5x1.5x0.083	.051	77.693	11	.021	77.693	y	6	3933.681	14085.15	624.421	624.421	1...	H1-1b*	
5	M50	Pipe 2.0 A2...	.178	53.493	6	.165	53.493		6	16304.154	23232.186	1397.505	1397.505	1.7	H1-1b	
6	M51	Pipe 2.0 A2...	.616	3.739	6	.173	0		6	5242.145	23232.186	1397.505	1397.505	1...	H1-1a	
7	M52	1.5x1.5x0.083	.828	62.776	6	.005	120.53	y	10	1634.463	14085.15	624.421	624.421	1...	H1-1a	
8	M73	Pipe 2.0 A2...	.170	53.493	6	.149	53.493		6	16304.154	23232.186	1397.505	1397.505	1...	H1-1b	
9	M74	Pipe 2.0 A2...	.579	3.739	6	.156	0		6	5242.145	23232.186	1397.505	1397.505	1...	H1-1a	
10	M75	1.5x1.5x0.083	.745	62.776	6	.015	120.53	y	7	1634.463	14085.15	624.421	624.421	1...	H1-1a	
11	M75B	1.5x1.5x0.083	.051	77.816	11	.021	0	y	6	3921.257	14085.15	624.421	624.421	1...	H1-1b*	



JOB NO.: U2716.0319.211

PROJECT: Sunturf Package B6

SUBJECT: CALCULATIONS

DESIGN APPROACH ASD

CONNECTION CAPACITY

Location: Column Base (set screws)

Connection Type: M16 Conical Set Screws

Tensile Capacity: 2603 lbs (AISC Equation J3-1)

Tension Load: 1681 lbs

Check Connection: 64.6%

Result: **Select M16 Conical Set Screws**

Note: Uplift capacity. FOS of (2)

CONNECTION CAPACITY

Location: Column to Cross Beam

Connection Type: K10341-002

Tensile Capacity: 2195 lbs

Tension Load: 1310 lbs

Check Connection: 59.7%

Result: **Select K10341-002**

Note: Uplift capacity. FOS of (2)



JOB NO.: U2716.0319.211

PROJECT: Sunturf Package B6

SUBJECT: CALCULATIONS

CONNECTION CAPACITY

Location: Brace to Column

Connection Type: K10219-001

Capacity: 1335 lbs (AISC Equation J3-1)

Tension Load: 1316 lbs

Check Connection: 98.6%

Result: **Select K10219-001**

Note: Axial capacity. FOS of (2)

BOLTED TENSION CONNECTION

Location: Rail to Cross Beam

Bolt Grade: A304 SS (A2-70)

Bolt Diameter: 0.375 in

Number of Bolts: 2

Bolt Capacity: 8410 lbs (AISC Equation J3-1)

Tension Load: 873 lbs

Check Bolt: 10.4%

Result: **Select (2) 0.375 in. dia. A304 SS (A2-70) bolts.**

Note:
