



Project Number: U2716-0319-211

August 16, 2021

Sunmodo
14800 NE 65th Street
Vancouver, WA 98682

**REFERENCE: Sunmodo Sunturf Ground Mount B6 (85x45)
Ground Mount PV Array Installation**

To Whom It May Concern:

Per request of Sunmodo, we have been asked to prepare the structural design of a ground-mounted PV solar array system with several foundation options as shown in the attached calculations. Vector Structural Engineering requires that we review each site specific install, and we are not liable for installs at site specific locations we have not reviewed. The following design parameters are used in our analysis:

- Code: International Building Code, 2015 Edition
- Minimum Design Loads for Buildings and Other Structures (ASCE 7-10)
- Design wind speed for risk category I structures: 105 mph
- Wind exposure: C
- Ground snow load: 30 psf
- The ground screws and helical piers must be tested to 1.5 times uplift and 2.0 times lateral reactions found in the table below. A minimum of one ground screw or helical pier must be tested.

Load (ASD)	Value (lbs)	Factor of Safety	Test Value (lbs)
UPLIFT	1943	1.5	2915
LATERAL	1294	2	2588

Foundation concrete shall have a minimum compressive strength of 2500 psi at 28 days. Cement for all concrete shall be Type I or II with a minimum of 6% entrained air with a water/cement ratio of 0.50. Maximum aggregate size shall be 3/4". No special inspection of concrete strength is required.

Footings are designed based on an allowable soil bearing pressure of 1500 psf an allowable skin friction of 250 psf, an allowable lateral bearing pressure of 150 pcf, and a coefficient of friction of 0.3. Vector Structural Engineering strongly recommends independent soils testing be performed by a licensed geotechnical engineer to verify the assumed soil parameters.

All ground mounts are to be installed per manufacturer’s recommendations. The use of solar panel support span tables provided by the manufacturer is allowed only where the site conditions and solar panel configuration match the description of the span tables. Electrical engineering is beyond our scope. All work performed must be in accordance with accepted industry-wide methods and applicable safety standards. Vector Structural Engineering assumes no responsibility for improper installation of the solar panels.

Very truly yours,

VECTOR STRUCTURAL ENGINEERING, LLC

Russell Emery, P.E.
Project Engineer

Enclosures

RNE/stb



08/16/2021



JOB NO. U2716-0319-211
 PROJECT SUNMODO SUNTURF GROUND MOUNTS B6
 SUBJECT ALL OPTIONS

651 W GALENA PARK BLVD. #101 (801) 990-1775
 DRAPER, UTAH 84020 (801) 990-1776 FAX

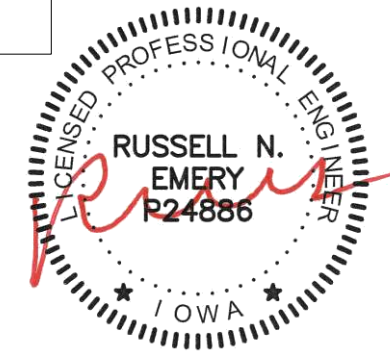
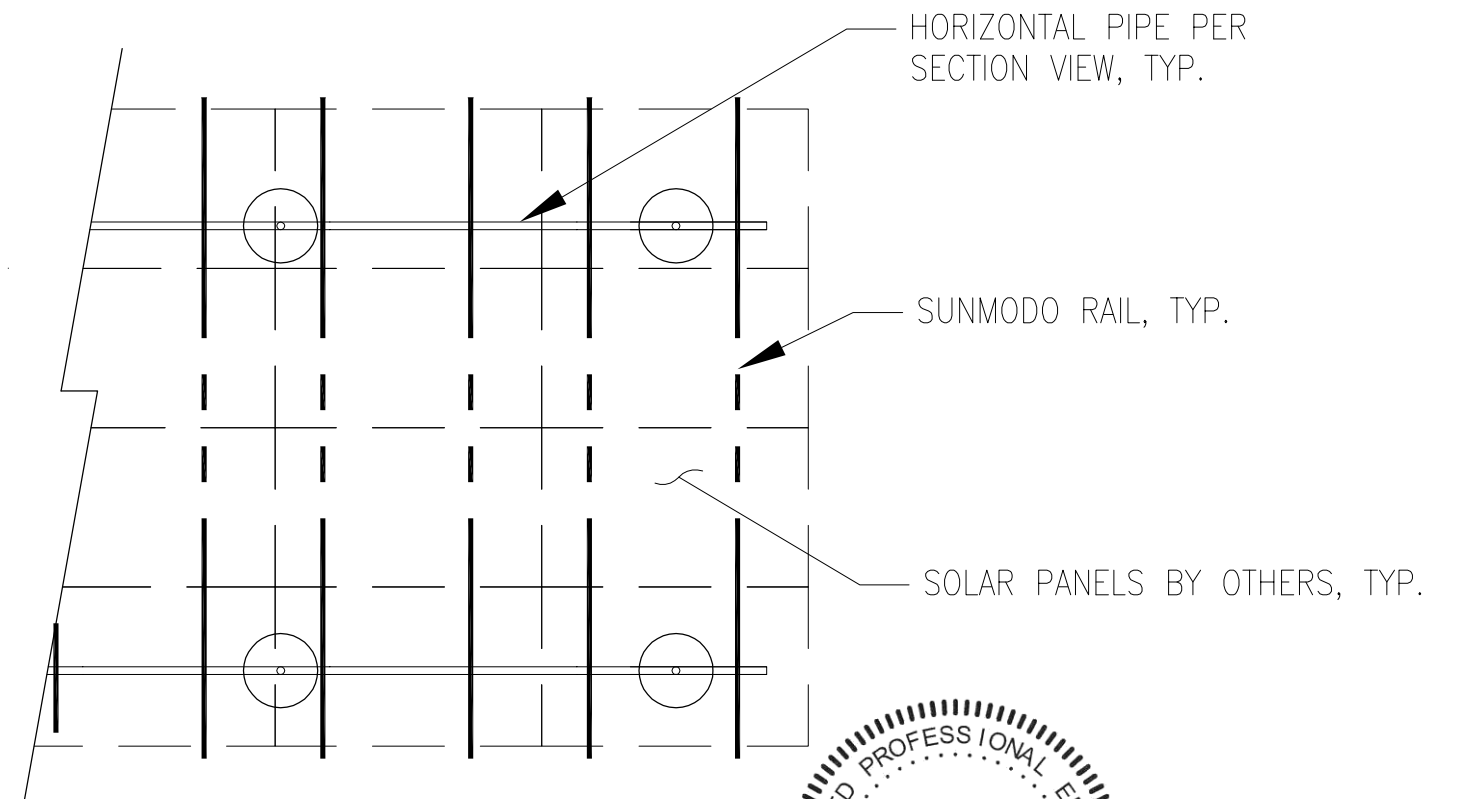
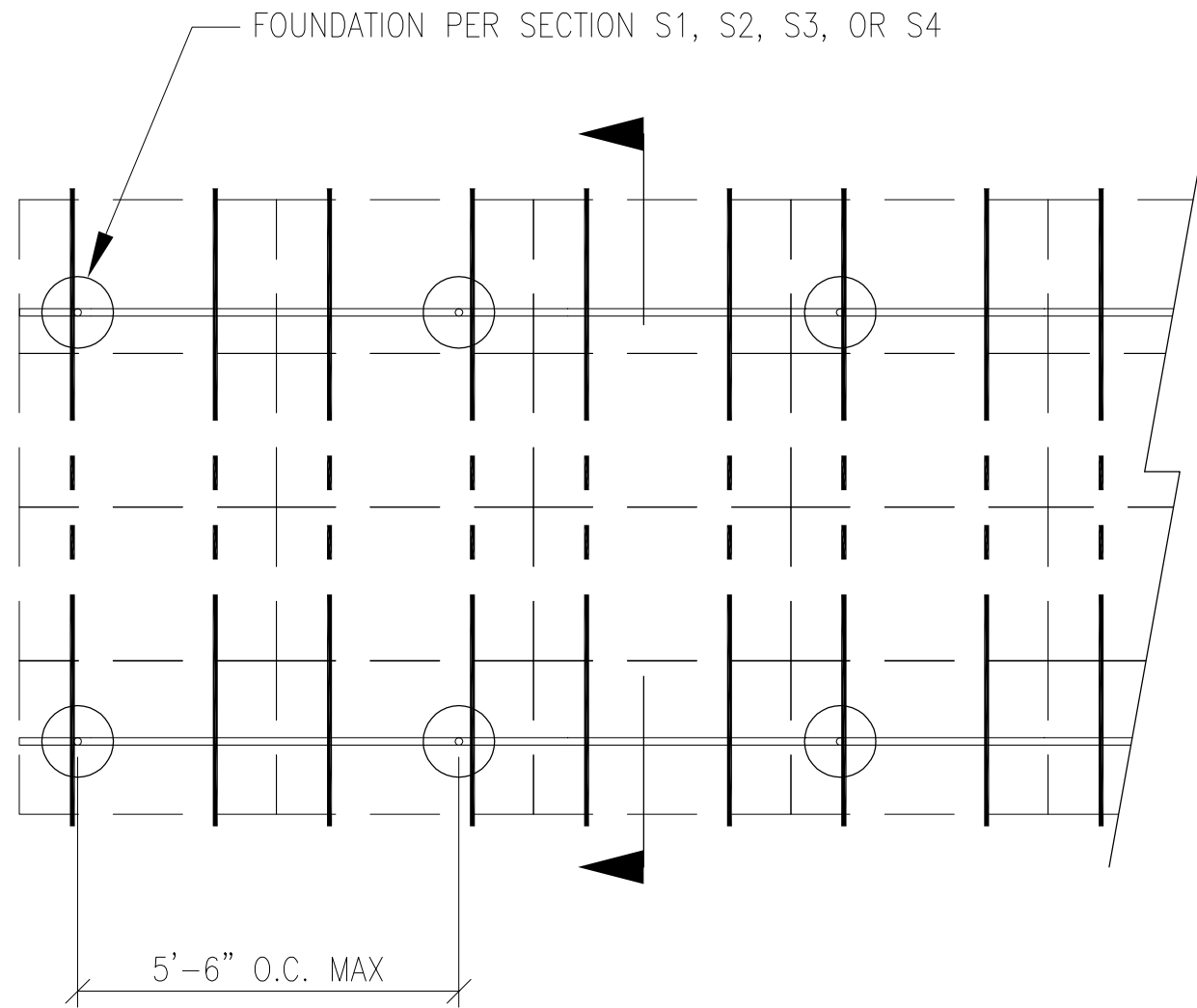

08/16/2021

PV ARRAY PLAN

N.T.S.

P1

PROJECT SUNMODO SUNTURF GROUND MOUNTS B6

SUBJECT DRILLED PIER OPTION

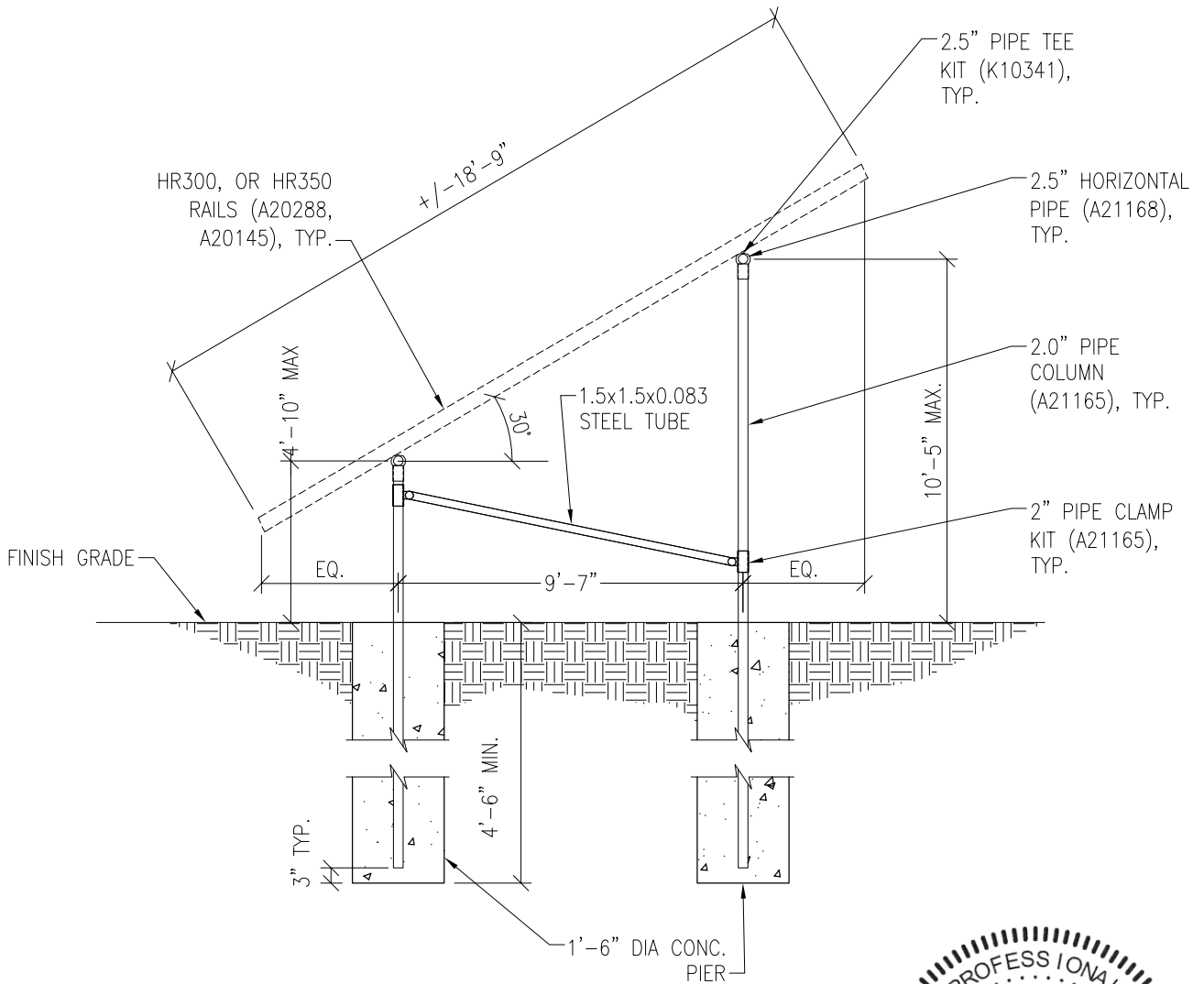

Vector Structural Engineering requires that we review each site specific install, and we are not liable for installs at site specific locations we have not reviewed



PV ARRAY SECTION

N.T.S.

S1

08/16/2021

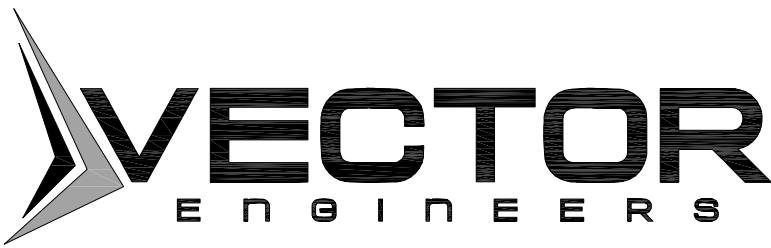

JOB NO. U2716-0319-211

PROJECT SUNMODO SUNTURF GROUND MOUNTS B6

SUBJECT HELICAL PIER OPTION

NOTES:

1. For ground mount components see Section S1.
2. A minimum of (1) installed helical pier must be tested as follows:
 - 2.1. Safety factor for uplift to be 1.5
 - 2.2. S.F. for lateral loads to be 2.0
 - 2.3. Upward deflection limit = 1/2"
 - 2.4. Lateral deflection limit = 1"
 - 2.5. The load tests must be performed by an approved contractor

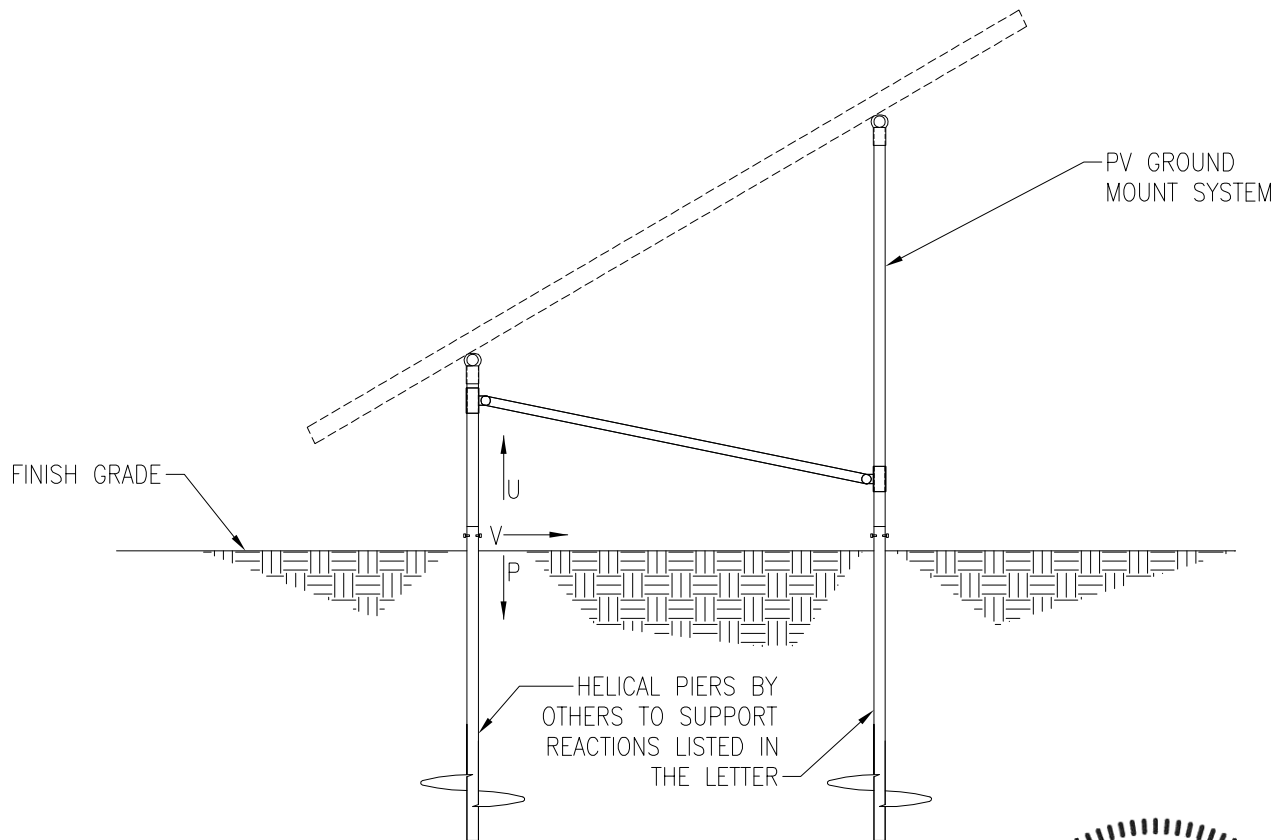

Vector Structural Engineering requires that we review each site specific install, and we are not liable for installs at site specific locations we have not reviewed

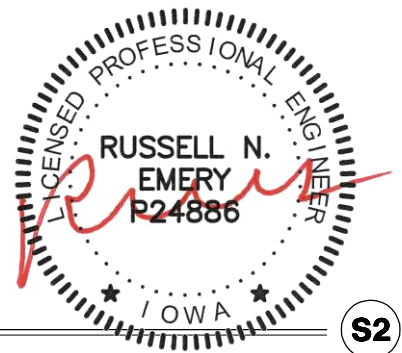

PV ARRAY SECTION

N.T.S.

08/16/2021

S2

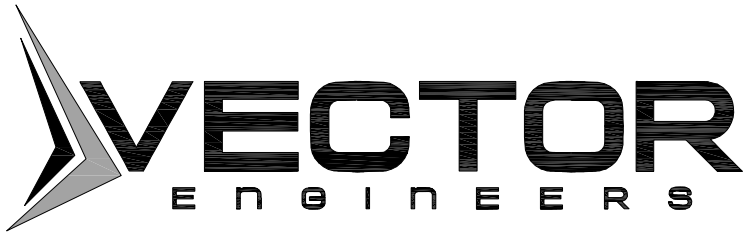

JOB NO. U2716-0319-211

PROJECT SUNMODO SUNTURF GROUND MOUNTS B6

SUBJECT GROUND SCREW OPTION

NOTES:

- 1. For ground mount components see Section S1.
- 2. A minimum of (1) installed ground screw must be tested as follows:
 - 2.1. Safety factor for uplift to be 1.5
 - 2.2. S.F. for lateral loads to be 2.0
 - 2.3. Upward deflection limit = 1/2"
 - 2.4. Lateral deflection limit = 1"
 - 2.5. The load tests must be performed by an approved contractor

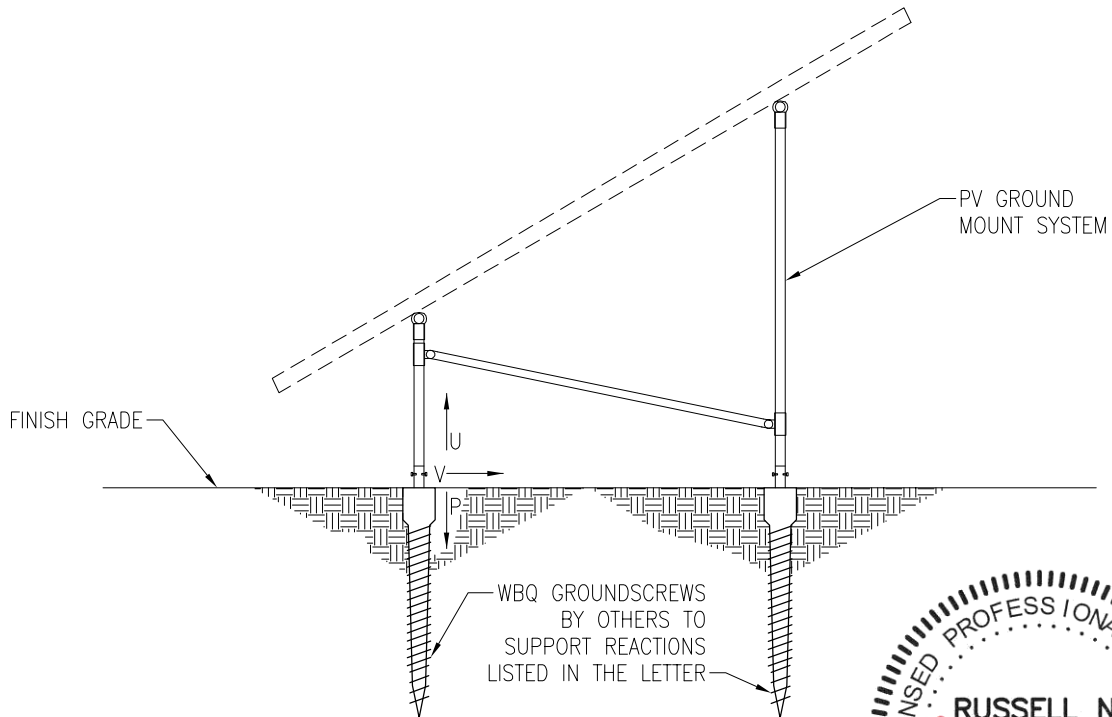

Vector Structural Engineering requires that we review each site specific install, and we are not liable for installs at site specific locations we have not reviewed

PV ARRAY SECTION

N.T.S.

08/16/2021

S3



JOB NO. U2716-0319-211

PROJECT SUNMODO SUNTURF GROUND MOUNTS B6

SUBJECT BALLASTED BLOCK OPTION

NOTES:

1. For ground mount components see Section S1.

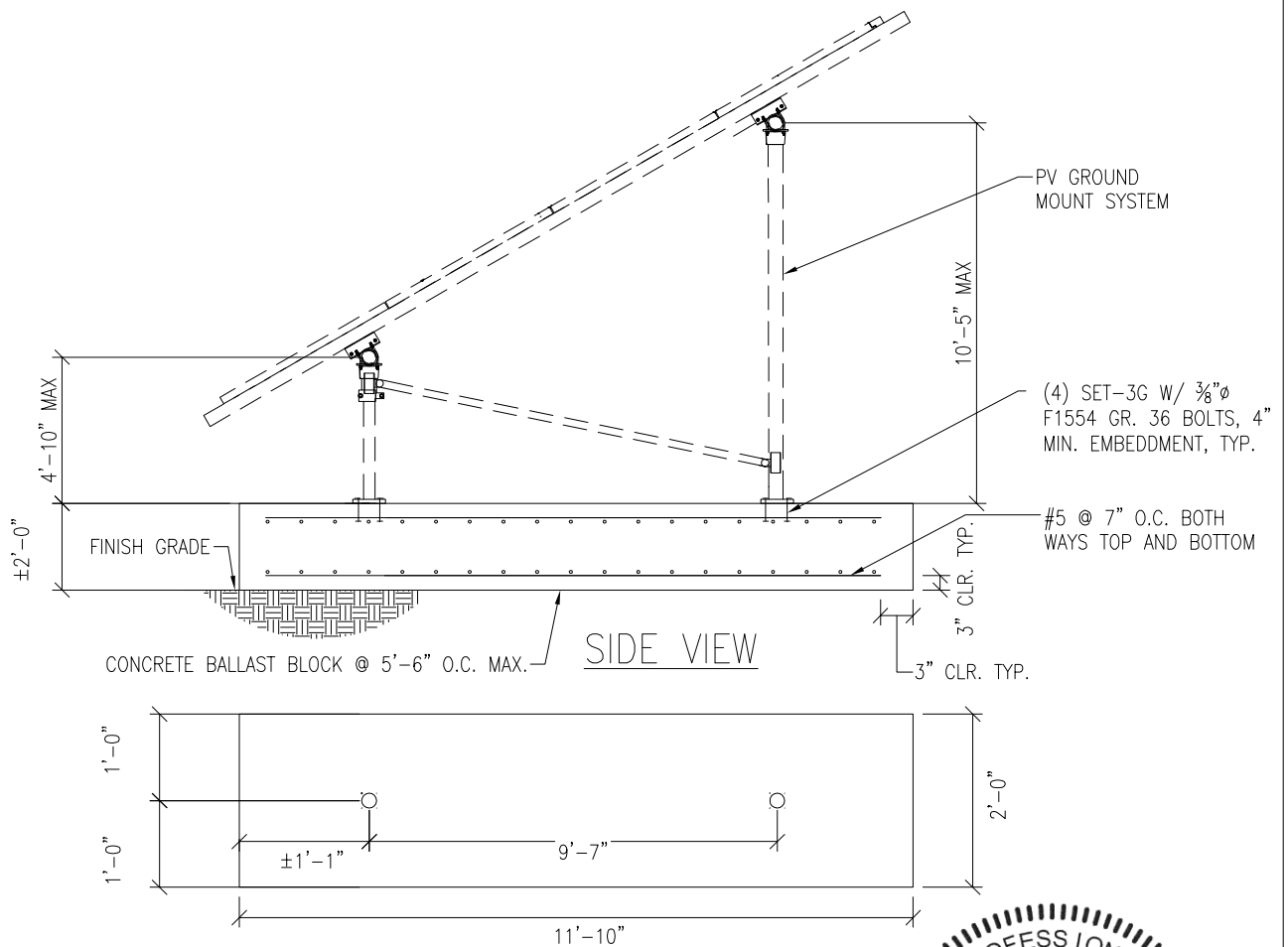

Vector Structural Engineering requires that we review each site specific install, and we are not liable for installs at site specific locations we have not reviewed

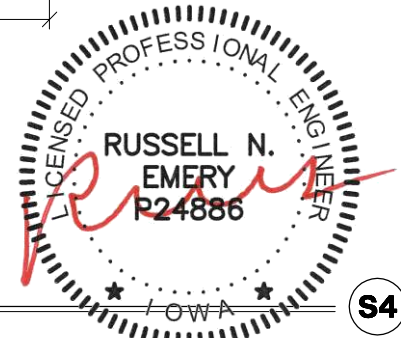

PV ARRAY SECTION

N.T.S.

S4

651 W GALENA PARK BLVD. #101
 DRAPER, UTAH 84020

(801) 990-1775
 (801) 990-1776 FAX

08/16/2021

WWW.VECTORSE.COM



PROJECT: Sunturf Package B6 Ground Mount

SNOW LOADS

Calculations Per:	ASCE 7-10	
Snow Ground Load, p_g [psf]:	30.0	(Section 7.2)
Risk Category:	I	(Table 1.5-1)
Importance Factor, I_s :	0.8	(Table 1.5-2)
Terrain Category:	C	(Section 26.7)
Exposure of Roof:	Fully Exposed	(Table 7-2)
Exposure Factor, C_e :	0.9	(Table 7-2)
Thermal Factor, C_t :	1.2	(Table 7-3)
Flat Roof Snow Load, p_f [psf]:	18	(Equation 7.3-1)
Min. Roof Snow Load, p_m [psf]:	0	(Section 7.3.4)
Panel Slope from Horizontal [°]:	30.0	
Unobstructed Slippery Surface?	Yes	(Section 7.4)
Slope Factor Figure:	Figure 7-2c	(Section 7.4)
Roof Slope Factor, C_s :	0.73	
Sloped Roof Snow Load, p_s [psf]:	13	(Equation 7.4-1)
Design Snow Load, S [psf]:	13	(1.0 Snow)



PROJECT: Sunturf Package B6 Ground Mount

WIND PRESSURES

Calculations per:	ASCE 7-10	
Design Wind Speed, V [mph]:	105	
Risk Category:	I	(Table 1.5-1)
Exposure Category:	C	(Section 26.7)
Elevation [ft]:	1217.2	
Ground Elevation Factor, K_e :		(Not applicable)
α :	9.5	(Table 26.9.1)
z_g [ft]:	900	(Table 26.9.1)
Velocity Pressure Exposure Coefficient, K_h :	0.85	(Table 27.3-1)
Topographic Factor, K_{ht} :	1.0	(Section 26.8)
Wind Directionality Factor, K_d :	0.85	(Table 26.6-1)
Internal Pressure Coefficient, GC_{pi} :	0.00	(Figure 26.11-1)
Velocity Pressure, q_h [psf]:	20.37	(Equation 27.3-1)
Gust Effect Factor, G:	0.85	(Section 26.9.1)
Panel Slope [degrees]:	30.0	
Wind Flow:	Clear	
Roof Configuration:	Monoslope	

Wind Pressures in Transverse (N-S) Direction

Net Pressure Coefficients per Figure 27.4-4

Clear Wind Flow	C_{NW}	C_{NL}
Case 1 ($\gamma = 0^\circ$, Load Case A)	-1.8	-1.8
Case 2 ($\gamma = 0^\circ$, Load Case B)	-2.5	-0.5
Case 3 ($\gamma = 180^\circ$, Load Case A)	2.1	2.1
Case 4 ($\gamma = 180^\circ$, Load Case B)	2.6	1.0

Design Wind Pressures per Equation 27.4-3 [psf]

Clear Wind Flow	$q_h GC_{NW}$	$q_h GC_{NL}$
Case 1 ($\gamma = 0^\circ$, Load Case A)	-31.2	-31.2
Case 2 ($\gamma = 0^\circ$, Load Case B)	-43.3	-8.7
Case 3 ($\gamma = 180^\circ$, Load Case A)	36.4	36.4
Case 4 ($\gamma = 180^\circ$, Load Case B)	45.0	17.3
Case 5 ($\gamma = 0^\circ$, 16 psf Min. Horiz.)	-16.0	-16.0
Case 6 ($\gamma = 180^\circ$, 16 psf Min. Horiz.)	16.0	16.0



JOB NO.: U2716-0319-211

DESIGNED: STB

Foundation Option 1: Drilled Concrete Pier



PROJECT: Sunturf Package B6 Ground Mount

DRILLED CONCRETE PIER DESIGN

Column Reactions:

Max. Shear, V [k]:	1.3	Max. Down, P _d [k]:	2.5
Max. Moment, M [k-ft]:	0.0	Max. Uplift, P _u [k]:	1.9

Pier Properties:

Pier Shape:	Round	Volume of Concrete [ft ³]:	8
Pier Diameter, b [ft]:	1.5	Volume of Concrete [yd ³]:	0.3
Top of Pier Elevation [ft]:	0.00	Weight of Concrete [k]:	1.2
Pier Depth, d [ft]:	4.5		

Soil Properties:

Allow. Bearing Pressure [psf]:	1,500	<u>Optional Parameters for Uplift:</u>	
1/3 increase for short term loads?	No		
Lateral Bearing, S [pcf]:	150	Skin Friction* [psf]:	250
Max. Lateral Bearing (opt'l) [psf]:		Top Length to Ignore [ft]:	0
Top Depth to Ignore [ft]:	0	1/3 increase for short term loads?	No
1/3 increase for short term loads?	No	Combine w/ Bearing:	No
1/2" deflection at t/o pier allowed:	Yes		

*per IBC Section 1810.3.3.1.4

Check Bearing:

Bearing Capacity [k]:	5.3
-----------------------	-----

Bearing capacity OK.

Check Uplift:

Uplift Capacity [k]:	6.4
----------------------	-----

Uplift capacity OK.

Check Lateral Bearing:

Top of Pier Constrained?:	No	IBC Section 1807.3.2.1
Applied Lateral Force, P [lb]:	1,294	
Point of Application, h [ft]:	0.0	
S _{max} [psf]:		
S [psf]:	450	
A = 2.34*P/(S _b):	4.49	
Required Pier Depth, d _{reqd} [ft]:	4.50	IBC Eq. 18-1

Result: **Lateral bearing capacity OK.**

Foundation Option 2: Helical Pier

The ground screws and helical piers must be tested to 1.5 times uplift and 2.0 times lateral reactions found in the table below. A minimum of one ground screw or helical pier must be tested.

Load (ASD)	Value (lbs)	Factor of Safety	Test Value (lbs)
UPLIFT	1943	1.5	2915
LATERAL	1294	2	2588

Foundation Option 3: Ground Screw

The ground screws and helical piers must be tested to 1.5 times uplift and 2.0 times lateral reactions found in the table below. A minimum of one ground screw or helical pier must be tested.

Load (ASD)	Value (lbs)	Factor of Safety	Test Value (lbs)
UPLIFT	1943	1.5	2915
LATERAL	1294	2	2588



JOB NO.: U2716-0319-211

DESIGNED: STB

Foundation Option 4: Ballasted Block

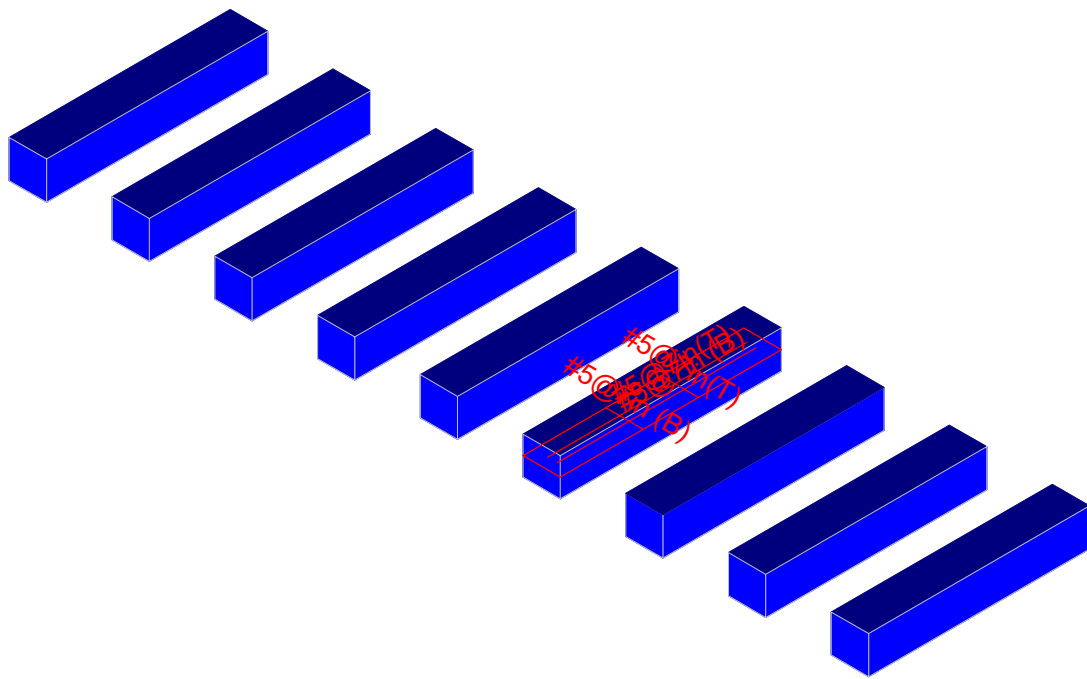

Results for LC 2, 1.0 D

Vector Structural Engineeri..	Ground Mount	SK - 2
STB		Aug 17, 2021 at 10:54 AM
U2716.0319.211		Sunturf Ground Mount B6 85x45.r3d

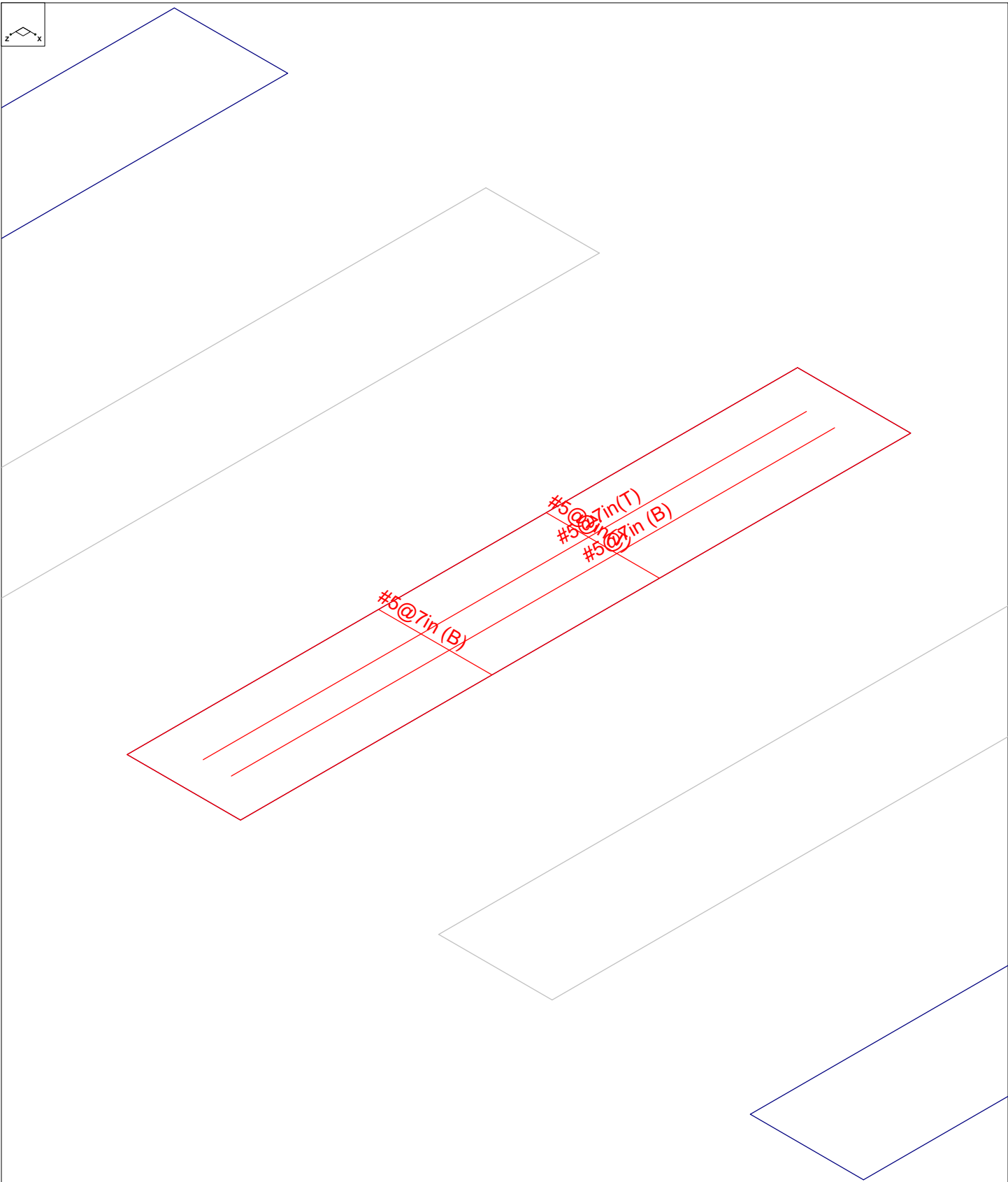

Results for LC 2, 1.0 D

Vector Structural Engineeri..	Ground Mount	SK - 1
STB		Aug 17, 2021 at 10:54 AM
U2716.0319.211		Sunturf Ground Mount B6 85x45.r3d



(Global) Model Settings

Display Sections for Member Calcs	5
Max Internal Sections for Member Calcs	100
Mesh Size (in)	12
Max Iterations	10
Merge Tolerance (in)	.12
Solver	Sparse Accelerated
Coefficient of Friction	.3
No. of Shear Regions	4
Shear Region Spacing Increment (in)	4
Min 1 Bar Dia Spacing for Beams?	No
Optimize footings for OTM / Sliding?	Yes
Parame Beta Factor	.65
Pile Safety Factor	3
Concrete Stress Block	0
Concrete Rebar Set	Rectangular
Concrete Code	ASTM A615
HR Steel Pile Code	ACI 318-14
Wood Pile Code	AISC 14th (360-10): ASD AWC NDS-15: ASD

Concrete Properties

	Label	E [ksi]	G [ksi]	Nu	Therm (/...	Density[lb/ft^3]	fc[psi]	Lambda	Flex Stee...	Shear St...
1	Conc3000NW	3156	1372	.15	.6	145	3000	1	60000	60000
2	Conc3500NW	3409	1482	.15	.6	145	3500	1	60000	60000
3	Conc4000NW	3644	1584	.15	.6	145	4000	1	60000	60000
4	Conc3000LW	2085	907	.15	.6	109.999	3000	.75	60000	60000
5	Conc3500LW	2252	979	.15	.6	109.999	3500	.75	60000	60000
6	Conc4000LW	2408	1047	.15	.6	109.999	4000	.75	60000	60000
7	Conc2500NW	3156	1372	.15	.6	145	2500	1	60000	60000

General Design Parameters

	Label	Max Bending Chk	Max Shear Chk	Top Cover[in]	Bottom Cover[in]
1	Typical	1	1	3	3

Slab Rebar Parameters

	Label	Top Bar	Bottom Bar	Max Top Bar Sp...	Min Top Bar Sp...	Max Bot Bar Sp...	Min Bot Bar Sp...	Spacing Incr...	Rebar Options
1	Typical	#5	#5	7	3	7	3	1	Optimize

Soil Definitions

	Label	Subgrade Modulus[lb/ft^3]	Allowable Bearing[psf]	Depth Properties	Default?
1	Default	1e+5	1500	None	Yes

Slabs

	Label	Thickness [in]	Material	Local Axis Angle ...	Analysis Offset [in]	Passive Pressur...	Soil Overburden [psf]
1	S1	24	Conc2500NW	0	0	0	0
2	S2	24	Conc2500NW	0	0	0	0
3	S3	24	Conc2500NW	0	0	0	0
4	S4	24	Conc2500NW	0	0	0	0
5	S5	24	Conc2500NW	0	0	0	0
6	S6	24	Conc2500NW	0	0	0	0
7	S7	24	Conc2500NW	0	0	0	0
8	S8	24	Conc2500NW	0	0	0	0



Company : Vector Structural Engineering
 Designer : STB
 Job Number : U2716.0319.211
 Model Name : Ground Mount

Aug 17, 2021
 10:54 AM
 Checked By: _____

Slabs (Continued)

	Label	Thickness [in]	Material	Local Axis Angle ...	Analysis Offset [in]	Passive Pressur...	Soil Overburden [psf]
9	S9	24	Conc2500NW	0	0	0	0

Load Combinations

Label	Solve	Service A	SF	Ca	Fa	Ca	Fa	Ca	Fa	Ca	Fa	Ca	Fa	Ca	Fa	Ca	Fa	C	F	C	F
1	ASD Loads																				
2	1.0 D	Yes	Yes	1.5	DL	1															
3	1.0 D + 1.0 S	Yes	Yes	1.5	DL	1	RLL	1													
4	1.0 D + 0.6 W1	Yes	Yes	1.5	DL	1	RLL		OL1	.6											
5	1.0 D + 0.6 W2	Yes	Yes	1.5	DL	1	RLL		OL2	.6											
6	1.0 D + 0.6 W3	Yes	Yes	1.5	DL	1	RLL		OL3	.6											
7	1.0 D + 0.6 W4	Yes	Yes	1.5	DL	1	RLL		OL4	.6											
8	1.0 D + 0.45 ...	Yes	Yes	1.5	DL	1	RLL	.75	OL1	.45											
9	1.0 D + 0.45 ...	Yes	Yes	1.5	DL	1	RLL	.75	OL2	.45											
10	1.0 D + 0.45 ...	Yes	Yes	1.5	DL	1	RLL	.75	OL3	.45											
11	1.0 D + 0.45 ...	Yes	Yes	1.5	DL	1	RLL	.75	OL4	.45											
12	0.9 D + 0.6 W1	Yes	Yes		DL	.9	RLL		OL1	.6											
13	0.9 D + 0.6 W2	Yes	Yes		DL	.9	RLL		OL2	.6											
14	0.9 D + 0.6 W3	Yes	Yes		DL	.9	RLL		OL3	.6											
15	0.9 D + 0.6 W4	Yes	Yes		DL	.9	RLL		OL4	.6											
16																					
17	LRFD Loads																				
18	1.4 D	Yes			DL	1.4	RLL														
19	1.2 D + 1.6 S...	Yes			DL	1.2	RLL	1.6	OL1	.5											
20	1.2 D + 1.6 S...	Yes			DL	1.2	RLL	1.6	OL2	.5											
21	1.2 D + 1.6 S...	Yes			DL	1.2	RLL	1.6	OL3	.5											
22	1.2 D + 1.6 S...	Yes			DL	1.2	RLL	1.6	OL4	.5											
23	1.2 D + 1.0 W1	Yes			DL	1.2	RLL		OL1	1											
24	1.2 D + 1.0 W2	Yes			DL	1.2	RLL		OL2	1											
25	1.2 D + 1.0 W3	Yes			DL	1.2	RLL		OL3	1											
26	1.2 D + 1.0 W4	Yes			DL	1.2	RLL		OL4	1											
27	0.9 D + 1.0 W1	Yes			DL	.9	RLL		OL1	1											
28	0.9 D + 1.0 W2	Yes			DL	.9	RLL		OL2	1											
29	0.9 D + 1.0 W3	Yes			DL	.9	RLL		OL3	1											
30	0.9 D + 1.0 W4	Yes			DL	.9	RLL		OL4	1											

Design Strips

	Label	Rebar Angle from Pl...	No. of Design Cuts	Design Rule
1	DS1	0	50	Typical
2	DS2	90	50	Typical

Strip Reinforcing

Label	UC Top	LC	Top Bars	Governing ...	UC Bot	LC	Bot B...	Gover...	UC Shear	LC	Governing De...
1	DS1	.027	21	#5@7in	DS1-X25	.039	28	#5@7inDS1-...	.049	28	DS1-X9
2	DS2	0	27	#5@7in	DS2-X26	.002	21	#5@7inDS2-...	.005	21	DS2-X25

Slab Overturning Safety Factors (By Combination)

LC	Slab	Angle[deg]	Mo-xx[lb-ft]	Ms-xx[lb-ft]	Mo-zz[lb-ft]	Ms-zz[lb-ft]	Ms-xx/Mo-xx	Ms-zz/Mo-zz
1	2	S1	0	0	42971.871	0	7290.062	9.999+
2	2	S2	0	0	43146.542	0	7292.825	9.999+
3	2	S3	0	0	43125.665	0	7299.59	9.999+
4	2	S4	0	0	43103.75	0	7299.422	9.999+
5	2	S5	0	0	43050.546	0	7285.653	9.999+
6	2	S6	0	0	43122.611	0	7292.677	9.999+
7	2	S7	0	0	43150.017	0	7304.117	9.999+
8	2	S8	0	0	43001.038	0	7268.653	9.999+



Company : Vector Structural Engineering
 Designer : STB
 Job Number : U2716.0319.211
 Model Name : Ground Mount

Aug 17, 2021
 10:54 AM
 Checked By: _____

Slab Overturning Safety Factors (By Combination) (Continued)

LC	Slab	Angle[deg]	Mo-xx[lb-ft]	Ms-xx[lb-ft]	Mo-zz[lb-ft]	Ms-zz[lb-ft]	Ms-xx/Mo-xx	Ms-zz/Mo-zz
9	2	S9	0	0	43329.322	0	7355.411	9.999+
10	3	S1	0	0	49396.94	0	8401.167	9.999+
11	3	S2	0	0	50227.505	0	8438.752	9.999+
12	3	S3	0	0	50106.378	0	8475.202	9.999+
13	3	S4	0	0	50013.26	0	8477.505	9.999+
14	3	S5	0	0	49775.258	0	8412.363	9.999+
15	3	S6	0	0	50099.215	0	8439.743	9.999+
16	3	S7	0	0	50204.693	0	8493.007	9.999+
17	3	S8	0	0	49625.213	0	8346.699	9.999+
18	3	S9	0	0	50867.687	0	8671.172	9.999+
19	4	S1	0	18493.546	43280.156	1648.322	7290.062	2.34
20	4	S2	0	18580.367	43185.164	1652.874	7298.429	2.324
21	4	S3	0	19045.116	43252.942	1700.108	7299.59	2.271
22	4	S4	0	19310.888	43226.25	1687.116	7299.422	2.238
23	4	S5	0	18050.924	43189.751	1645.791	7290.151	2.393
24	4	S6	0	19755.552	43237.667	1707.138	7303.406	2.189
25	4	S7	0	18738.441	43282.161	1716.611	7304.117	2.31
26	4	S8	0	17605.273	43011.477	1520.855	7268.653	2.443
27	4	S9	0	21477.011	43656.93	1905.924	7346.47	2.033
28	5	S1	0	20434.934	43280.156	1460.596	7290.062	2.118
29	5	S2	0	20412.148	43185.164	1348.156	7298.429	2.116
30	5	S3	0	21067.899	43252.942	1433.024	7299.59	2.053
31	5	S4	0	21404.85	43226.25	1408.621	7299.422	2.019
32	5	S5	0	19837.923	43189.751	1384.415	7290.151	2.177
33	5	S6	0	21955.5	43237.667	1421.426	7303.406	1.969
34	5	S7	0	20662.061	43282.161	1446.874	7304.117	2.095
35	5	S8	0	19378.447	43011.477	1234.067	7268.653	2.22
36	5	S9	0	23732.629	43656.93	1693.574	7346.47	1.84
37	6	S1	0	0	43754.616	0	9213.104	9.999+
38	6	S2	0	0	44100.056	0	9189.358	9.999+
39	6	S3	0	0	44308.091	0	9283.05	9.999+
40	6	S4	0	0	43623.612	0	9267.724	9.999+
41	6	S5	0	0	44595.597	0	9186.031	9.999+
42	6	S6	0	0	43290.198	0	9224.796	9.999+
43	6	S7	0	0	44960.487	0	9302.297	9.999+
44	6	S8	0	0	43397.757	0	9042.984	9.999+
45	6	S9	0	0	44482.608	0	9561.651	9.999+
46	7	S1	0	2913.074	42971.871	0	9005.317	9.999+
47	7	S2	0	3349.472	43146.542	0	8902.078	9.999+
48	7	S3	0	2992.083	43125.665	0	9009.997	9.999+
49	7	S4	0	3685.966	43103.75	0	8985.988	9.999+
50	7	S5	0	2338.195	43050.546	0	8931.645	9.999+
51	7	S6	0	4152.739	43122.611	0	8964.455	9.999+
52	7	S7	0	2320.558	43150.017	0	9030.435	9.999+
53	7	S8	0	3725.95	43001.038	0	8757.767	9.999+
54	7	S9	0	3174.22	43329.322	0	9245.388	9.999+
55	8	S1	0	13870.16	48305.092	1236.242	8123.39	3.483
56	8	S2	0	13935.275	48130.304	1239.656	8172.366	3.454
57	8	S3	0	14283.837	48450.975	1275.081	8181.299	3.392
58	8	S4	0	14483.166	48340.037	1265.337	8182.984	3.338
59	8	S5	0	13538.193	48212.097	1234.344	8146.392	3.561
60	8	S6	0	14816.664	48383.842	1280.354	8197.238	3.266
61	8	S7	0	14053.83	48542.567	1287.458	8195.785	3.454
62	8	S8	0	13203.955	47559.626	1140.642	8077.188	3.602
63	8	S9	0	16107.758	49553.88	1429.443	8311.882	3.076
64	9	S1	0	15326.201	48305.092	1095.447	8123.39	3.152
65	9	S2	0	15309.111	48130.304	1011.117	8172.366	3.144



Company : Vector Structural Engineering
 Designer : STB
 Job Number : U2716.0319.211
 Model Name : Ground Mount

Aug 17, 2021
 10:54 AM
 Checked By: _____

Slab Overturning Safety Factors (By Combination) (Continued)

LC	Slab	Angle[deg]	Mo-xx[lb-ft]	Ms-xx[lb-ft]	Mo-zz[lb-ft]	Ms-zz[lb-ft]	Ms-xx/Mo-xx	Ms-zz/Mo-zz	
66	9	S3	0	15800.925	48450.975	1074.768	8181.299	3.066	7.612
67	9	S4	0	16053.638	48340.037	1056.466	8182.984	3.011	7.746
68	9	S5	0	14878.443	48212.097	1036.671	8130.686	3.24	7.843
69	9	S6	0	16466.625	48383.842	1066.07	8197.238	2.938	7.689
70	9	S7	0	15496.546	48542.567	1085.156	8195.785	3.132	7.553
71	9	S8	0	14533.835	47559.626	925.55	8068.501	3.272	8.718
72	9	S9	0	17799.472	49553.88	1270.181	8311.882	2.784	6.544
73	10	S1	0	0	48377.731	0	9565.672	9.999+	9.999+
74	10	S2	0	0	49172.4	0	9574.67	9.999+	9.999+
75	10	S3	0	0	49248.02	0	9668.894	9.999+	9.999+
76	10	S4	0	0	48675.78	0	9659.211	9.999+	9.999+
77	10	S5	0	0	49252.868	0	9555.969	9.999+	9.999+
78	10	S6	0	0	48480.754	0	9602.066	9.999+	9.999+
79	10	S7	0	0	49798.876	0	9694.42	9.999+	9.999+
80	10	S8	0	0	48266.709	0	9407.936	9.999+	9.999+
81	10	S9	0	0	49848.06	0	9996.912	9.999+	9.999+
82	11	S1	0	2184.806	47790.672	0	9409.832	9.999+	9.999+
83	11	S2	0	2512.104	48457.265	0	9359.21	9.999+	9.999+
84	11	S3	0	2244.062	48361.2	0	9464.104	9.999+	9.999+
85	11	S4	0	2764.474	48285.883	0	9447.91	9.999+	9.999+
86	11	S5	0	1753.647	48094.08	0	9365.179	9.999+	9.999+
87	11	S6	0	3114.554	48355.064	0	9406.81	9.999+	9.999+
88	11	S7	0	1740.419	48441.024	0	9490.523	9.999+	9.999+
89	11	S8	0	2794.462	47969.169	0	9194.023	9.999+	9.999+
90	11	S9	0	2380.665	48983.096	0	9759.714	9.999+	9.999+
91	12	S1	0	18493.546	38952.14	1648.322	6561.055	2.106	3.98
92	12	S2	0	18580.367	38866.647	1652.874	6568.586	2.092	3.974
93	12	S3	0	19045.116	38927.648	1700.108	6569.631	2.044	3.864
94	12	S4	0	19310.888	38903.625	1687.116	6569.479	2.015	3.894
95	12	S5	0	18050.924	38870.776	1645.791	6561.136	2.153	3.987
96	12	S6	0	19755.552	38913.9	1707.138	6573.065	1.97	3.85
97	12	S7	0	18738.441	38953.944	1716.611	6573.706	2.079	3.829
98	12	S8	0	17605.273	38710.329	1520.855	6541.788	2.199	4.301
99	12	S9	0	21477.011	39291.237	1905.924	6611.823	1.829	3.469
100	13	S1	0	20434.934	38952.14	1460.596	6561.055	1.906	4.492
101	13	S2	0	20412.148	38866.647	1348.156	6568.586	1.904	4.872
102	13	S3	0	21067.899	38927.648	1433.024	6569.631	1.848	4.584
103	13	S4	0	21404.85	38903.625	1408.621	6569.479	1.818	4.664
104	13	S5	0	19837.923	38870.776	1384.415	6561.136	1.959	4.739
105	13	S6	0	21955.5	38913.9	1421.426	6573.065	1.772	4.624
106	13	S7	0	20662.061	38953.944	1446.874	6573.706	1.885	4.543
107	13	S8	0	19378.447	38710.329	1234.067	6541.788	1.998	5.301
108	13	S9	0	23732.629	39291.237	1693.574	6611.823	1.656	3.904
109	14	S1	0	0	39457.428	0	8484.098	9.999+	9.999+
110	14	S2	0	0	39785.402	0	8460.075	9.999+	9.999+
111	14	S3	0	0	39995.525	0	8553.091	9.999+	9.999+
112	14	S4	0	0	39313.237	0	8537.781	9.999+	9.999+
113	14	S5	0	0	40290.542	0	8457.465	9.999+	9.999+
114	14	S6	0	0	38977.937	0	8495.528	9.999+	9.999+
115	14	S7	0	0	40645.485	0	8571.885	9.999+	9.999+
116	14	S8	0	0	39097.654	0	8316.119	9.999+	9.999+
117	14	S9	0	0	40149.676	0	8826.11	9.999+	9.999+
118	15	S1	0	2913.074	38674.684	0	8276.311	9.999+	9.999+
119	15	S2	0	3349.472	38831.888	0	8172.795	9.999+	9.999+
120	15	S3	0	2992.083	38813.099	0	8280.038	9.999+	9.999+
121	15	S4	0	3685.966	38793.375	0	8256.046	9.999+	9.999+
122	15	S5	0	2338.195	38745.491	0	8203.079	9.999+	9.999+



Company : Vector Structural Engineering
 Designer : STB
 Job Number : U2716.0319.211
 Model Name : Ground Mount

Aug 17, 2021
 10:54 AM
 Checked By: _____

Slab Overturning Safety Factors (By Combination) (Continued)

LC	Slab	Angle[deg]	Mo-xx[lb-ft]	Ms-xx[lb-ft]	Mo-zz[lb-ft]	Ms-zz[lb-ft]	Ms-xx/Mo-xx	Ms-zz/Mo-zz	
123	15	S6	0	4152.739	38810.35	0	8235.187	9.346	9.999+
124	15	S7	0	2320.558	38835.016	0	8300.024	9.999+	9.999+
125	15	S8	0	3725.95	38700.934	0	8030.902	9.999+	9.999+
126	15	S9	0	3174.22	38996.39	0	8509.846	9.999+	9.999+

Slab Sliding Safety Factors (By Combination)

LC	Slab	Angle[deg]	Va-xx[lb]	Vr-xx[lb]	Va-zz[lb]	Vr-zz[lb]	SR-xx	SR-zz	
1	2	S1	0	.584	2186.668	0	2186.668	9.999+	9.999+
2	2	S2	0	1.401	2188.688	0	2188.688	9.999+	9.999+
3	2	S3	0	0	2189.877	0	2189.877	9.999+	9.999+
4	2	S4	0	1.969	2188.645	0	2188.645	9.999+	9.999+
5	2	S5	0	1.124	2186.371	0	2186.371	9.999+	9.999+
6	2	S6	0	2.682	2189.412	0	2189.412	9.999+	9.999+
7	2	S7	0	0	2191.235	0	2191.235	9.999+	9.999+
8	2	S8	0	0	2180.596	0	2180.596	9.999+	9.999+
9	2	S9	0	2.235	2205.282	0	2205.282	9.999+	9.999+
10	3	S1	0	1.561	2519.414	0	2519.414	9.999+	9.999+
11	3	S2	0	6.232	2535.365	0	2535.365	9.999+	9.999+
12	3	S3	0	0	2542.561	0	2542.561	9.999+	9.999+
13	3	S4	0	10.96	2536.675	0	2536.675	9.999+	9.999+
14	3	S5	0	4.86	2526.625	0	2526.625	9.999+	9.999+
15	3	S6	0	13.86	2540.239	0	2540.239	9.999+	9.999+
16	3	S7	0	0	2547.902	0	2547.902	9.999+	9.999+
17	3	S8	0	2.895	2502.273	0	2502.273	9.999+	9.999+
18	3	S9	0	9.372	2595.729	0	2595.729	9.999+	9.999+
19	4	S1	0	13.812	1700.809	913.257	1700.809	9.999+	1.862
20	4	S2	0	5.418	1696.917	980.204	1696.917	9.999+	1.731
21	4	S3	0	2.508	1681.349	954.985	1681.349	9.999+	1.761
22	4	S4	0	6.809	1687.777	992.046	1687.777	9.999+	1.701
23	4	S5	0	3.1	1695.168	907.681	1695.168	9.999+	1.868
24	4	S6	0	10.077	1684.926	1022.504	1684.926	9.999+	1.648
25	4	S7	0	.971	1676.835	923.121	1676.835	9.999+	1.816
26	4	S8	0	2.176	1725.645	948.816	1725.645	9.999+	1.819
27	4	S9	0	5.95	1635.734	1059.085	1635.734	9.999+	1.544
28	5	S1	0	31.745	1767.887	765.478	1767.887	9.999+	2.31
29	5	S2	0	1.263	1785.839	830.322	1785.839	9.999+	2.151
30	5	S3	0	1.958	1761.144	798.796	1761.144	9.999+	2.205
31	5	S4	0	.243	1767.386	845.947	1767.386	9.999+	2.089
32	5	S5	0	.578	1771.374	742.147	1771.374	9.999+	2.387
33	5	S6	0	2.022	1765.807	883.43	1765.807	9.999+	1.999
34	5	S7	0	0	1757.173	754.807	1757.173	9.999+	2.328
35	5	S8	0	.823	1810.869	817.426	1810.869	9.999+	2.215
36	5	S9	0	31.05	1714.499	883.818	1714.499	9.999+	1.94
37	6	S1	0	17.379	2753.504	1065.466	2753.504	9.999+	2.584
38	6	S2	0	9.356	2762.421	1143.571	2762.421	9.999+	2.416
39	6	S3	0	2.926	2783.159	1114.149	2783.159	9.999+	2.498
40	6	S4	0	12.211	2772.991	1157.387	2772.991	9.999+	2.396
41	6	S5	0	6.053	2759.441	1058.961	2759.441	9.999+	2.606
42	6	S6	0	17.568	2777.979	1192.922	2777.979	9.999+	2.329
43	6	S7	0	1.133	2791.369	1076.975	2791.369	9.999+	2.592
44	6	S8	0	2.539	2711.372	1106.952	2711.372	9.999+	2.449
45	6	S9	0	2.099	2869.755	1235.599	2869.755	9.999+	2.323
46	7	S1	0	31.2	2682.875	915.341	2682.875	9.999+	2.931
47	7	S2	0	5.792	2674.099	989.429	2674.099	9.999+	2.703
48	7	S3	0	2.398	2701.56	955.836	2701.56	9.999+	2.826
49	7	S4	0	6.648	2691.807	1005.861	2691.807	9.999+	2.676



Company : Vector Structural Engineering
 Designer : STB
 Job Number : U2716.0319.211
 Model Name : Ground Mount

Aug 17, 2021
 10:54 AM
 Checked By: _____

Slab Sliding Safety Factors (By Combination) (Continued)

	LC	Slab	Angle[deg]	Va-xx[lb]	Vr-xx[lb]	Va-zz[lb]	Vr-zz[lb]	SR-xx	SR-zz
50	7	S5	0	3.041	2681.318	894.815	2681.318	9.999+	2.997
51	7	S6	0	10.526	2695.652	1045.958	2695.652	9.999+	2.577
52	7	S7	0	0	2709.131	910.065	2709.131	9.999+	2.977
53	7	S8	0	.062	2627.293	968.708	2627.293	9.999+	2.712
54	7	S9	0	22.064	2786.855	1058.386	2786.855	9.999+	2.633
55	8	S1	0	9.481	2071.833	684.943	2071.833	9.999+	3.025
56	8	S2	0	.09	2079.867	735.153	2079.867	9.999+	2.829
57	8	S3	0	1.881	2072.994	716.239	2072.994	9.999+	2.894
58	8	S4	0	2.129	2074.017	744.034	2074.017	9.999+	2.788
59	8	S5	0	.758	2073.159	680.761	2073.159	9.999+	3.045
60	8	S6	0	1.496	2074.168	766.878	2074.168	9.999+	2.705
61	8	S7	0	.729	2072.935	692.341	2072.935	9.999+	2.994
62	8	S8	0	.54	2080.64	711.612	2080.64	9.999+	2.924
63	8	S9	0	10.374	2070.956	794.314	2070.956	9.999+	2.607
64	9	S1	0	22.93	2122.141	574.109	2122.141	9.999+	3.696
65	9	S2	0	3.026	2146.559	622.741	2146.559	9.999+	3.447
66	9	S3	0	1.468	2132.84	599.097	2132.84	9.999+	3.56
67	9	S4	0	7.053	2133.724	634.461	2133.724	9.999+	3.363
68	9	S5	0	3.516	2130.314	556.61	2130.314	9.999+	3.827
69	9	S6	0	7.537	2134.828	662.573	2134.828	9.999+	3.222
70	9	S7	0	0	2133.189	566.105	2133.189	9.999+	3.768
71	9	S8	0	2.788	2144.559	613.07	2144.559	9.999+	3.498
72	9	S9	0	29.199	2130.03	662.864	2130.03	9.999+	3.213
73	10	S1	0	13.913	2861.354	799.1	2861.354	9.999+	3.581
74	10	S2	0	10.99	2878.995	857.679	2878.995	9.999+	3.357
75	10	S3	0	2.194	2899.352	835.612	2899.352	9.999+	3.47
76	10	S4	0	16.394	2887.927	868.04	2887.927	9.999+	3.327
77	10	S5	0	7.623	2871.364	794.221	2871.364	9.999+	3.615
78	10	S6	0	22.229	2893.957	894.691	2893.957	9.999+	3.235
79	10	S7	0	.85	2908.836	807.731	2908.836	9.999+	3.601
80	10	S8	0	4.075	2819.936	830.214	2819.936	9.999+	3.397
81	10	S9	0	4.336	2996.472	926.699	2996.472	9.999+	3.233
82	11	S1	0	24.278	2808.383	686.505	2808.383	9.999+	4.091
83	11	S2	0	8.317	2812.753	742.072	2812.753	9.999+	3.79
84	11	S3	0	1.799	2838.152	716.877	2838.152	9.999+	3.959
85	11	S4	0	12.222	2827.04	754.396	2827.04	9.999+	3.747
86	11	S5	0	5.364	2812.772	671.111	2812.772	9.999+	4.191
87	11	S6	0	16.948	2832.212	784.469	2832.212	9.999+	3.61
88	11	S7	0	0	2847.157	682.548	2847.157	9.999+	4.171
89	11	S8	0	2.218	2756.876	726.531	2756.876	9.999+	3.795
90	11	S9	0	10.637	2934.296	793.79	2934.296	9.999+	3.697
91	12	S1	0	13.87	1482.142	913.257	1482.142	9.999+	1.623
92	12	S2	0	5.558	1478.048	980.204	1478.048	9.999+	1.508
93	12	S3	0	2.508	1462.362	954.985	1462.362	9.999+	1.531
94	12	S4	0	7.006	1468.912	992.046	1468.912	9.999+	1.481
95	12	S5	0	3.212	1476.531	907.681	1476.531	9.999+	1.627
96	12	S6	0	10.345	1465.985	1022.504	1465.985	9.999+	1.434
97	12	S7	0	.971	1457.711	923.121	1457.711	9.999+	1.579
98	12	S8	0	2.176	1507.585	948.816	1507.585	9.999+	1.589
99	12	S9	0	5.727	1415.206	1059.085	1415.206	9.999+	1.336
100	13	S1	0	31.803	1549.22	765.478	1549.22	9.999+	2.024
101	13	S2	0	1.403	1566.971	830.322	1566.971	9.999+	1.887
102	13	S3	0	1.958	1542.157	798.796	1542.157	9.999+	1.931
103	13	S4	0	.44	1548.521	845.947	1548.521	9.999+	1.831
104	13	S5	0	.465	1552.737	742.147	1552.737	9.999+	2.092
105	13	S6	0	2.291	1546.866	883.43	1546.866	9.999+	1.751
106	13	S7	0	0	1538.049	754.807	1538.049	9.999+	2.038



Company : Vector Structural Engineering
 Designer : STB
 Job Number : U2716.0319.211
 Model Name : Ground Mount

Aug 17, 2021
 10:54 AM
 Checked By: _____

Slab Sliding Safety Factors (By Combination) (Continued)

	LC	Slab	Angle[deg]	Va-xx[lb]	Vr-xx[lb]	Va-zz[lb]	Vr-zz[lb]	SR-xx	SR-zz
107	13	S8	0	.823	1592.81	817.426	1592.81	9.999+	1.949
108	13	S9	0	30.827	1493.971	883.818	1493.971	9.999+	1.69
109	14	S1	0	17.321	2534.837	1065.466	2534.837	9.999+	2.379
110	14	S2	0	9.216	2543.552	1143.571	2543.552	9.999+	2.224
111	14	S3	0	2.926	2564.172	1114.149	2564.172	9.999+	2.301
112	14	S4	0	12.014	2554.126	1157.387	2554.126	9.999+	2.207
113	14	S5	0	5.94	2540.804	1058.961	2540.804	9.999+	2.399
114	14	S6	0	17.3	2559.038	1192.922	2559.038	9.999+	2.145
115	14	S7	0	1.133	2572.246	1076.975	2572.246	9.999+	2.388
116	14	S8	0	2.539	2493.313	1106.952	2493.313	9.999+	2.252
117	14	S9	0	2.323	2649.227	1235.599	2649.227	9.999+	2.144
118	15	S1	0	31.141	2464.209	915.341	2464.209	9.999+	2.692
119	15	S2	0	5.652	2455.23	989.429	2455.23	9.999+	2.481
120	15	S3	0	2.398	2482.573	955.836	2482.573	9.999+	2.597
121	15	S4	0	6.451	2472.943	1005.861	2472.943	9.999+	2.459
122	15	S5	0	2.929	2462.681	894.815	2462.681	9.999+	2.752
123	15	S6	0	10.257	2476.711	1045.958	2476.711	9.999+	2.368
124	15	S7	0	0	2490.007	910.065	2490.007	9.999+	2.736
125	15	S8	0	.062	2409.233	968.708	2409.233	9.999+	2.487
126	15	S9	0	22.288	2566.327	1058.386	2566.327	9.999+	2.425

Envelope Slab Soil Pressures

	Label	UC	LC	Soil Pressure[psf]	Allowable Bearing[psf]	Point
1	S1	.409	7	613.604	1500	N1
2	S2	.407	7	611.072	1500	N37
3	S3	.414	7	620.814	1500	N40
4	S4	.419	7	628.352	1500	N45
5	S5	.4	7	599.777	1500	N49
6	S6	.426	7	638.288	1500	N53
7	S7	.408	7	612.29	1500	N56
8	S8	.398	7	596.675	1500	N60
9	S9	.443	7	663.968	1500	N64



Company:		Date:	5/14/2018
Engineer:		Page:	1/6
Project:			
Address:			
Phone:			
E-mail:			

1. Project information

Customer company:
Customer contact name:
Customer e-mail:
Comment:

Project description:
Location:
Fastening description:

2. Input Data & Anchor Parameters

General

Design method: ACI 318-14
Units: Imperial units

Anchor Information:

Anchor type: Bonded anchor
Material: F1554 Grade 36
Diameter (inch): 0.375
Effective Embedment depth, h_{ef} (inch): 4.000
Code report: ICC-ES ESR-4057
Anchor category: -
Anchor ductility: Yes
 h_{min} (inch): 5.25
 c_{ac} (inch): 7.12
 C_{min} (inch): 1.75
 S_{min} (inch): 1.00

Base Material

Concrete: Normal-weight
Concrete thickness, h (inch): 24.00
State: Cracked
Compressive strength, f'_c (psi): 2500
 $\Psi_{c,v}$: 1.0
Reinforcement condition: B tension, B shear
Supplemental reinforcement: Not applicable
Reinforcement provided at corners: No
Ignore concrete breakout in tension: No
Ignore concrete breakout in shear: No
Hole condition: Dry concrete
Inspection: Periodic
Temperature range, Short/Long: 150/110°F
Ignore 6do requirement: Not applicable
Build-up grout pad: No

Base Plate

Length x Width x Thickness (inch): 4.75 x 4.75 x 0.31

Recommended Anchor

Anchor Name: SET-3G - SET-3G w/ 3/8"Ø F1554 Gr. 36
Code Report: ICC-ES ESR-4057





Company:		Date:	5/14/2018
Engineer:		Page:	2/6
Project:			
Address:			
Phone:			
E-mail:			

Load and Geometry

Load factor source: ACI 318 Section 5.3

Load combination: not set

Seismic design: No

Anchors subjected to sustained tension: No

Apply entire shear load at front row: No

Anchors only resisting wind and/or seismic loads: No

Strength level loads:

N_{ua} [lb]: 3266

V_{uax} [lb]: 55

V_{uay} [lb]: -2153

M_{ux} [ft-lb]: 0

M_{uy} [ft-lb]: 0

M_{uz} [ft-lb]: 0

<Figure 1>

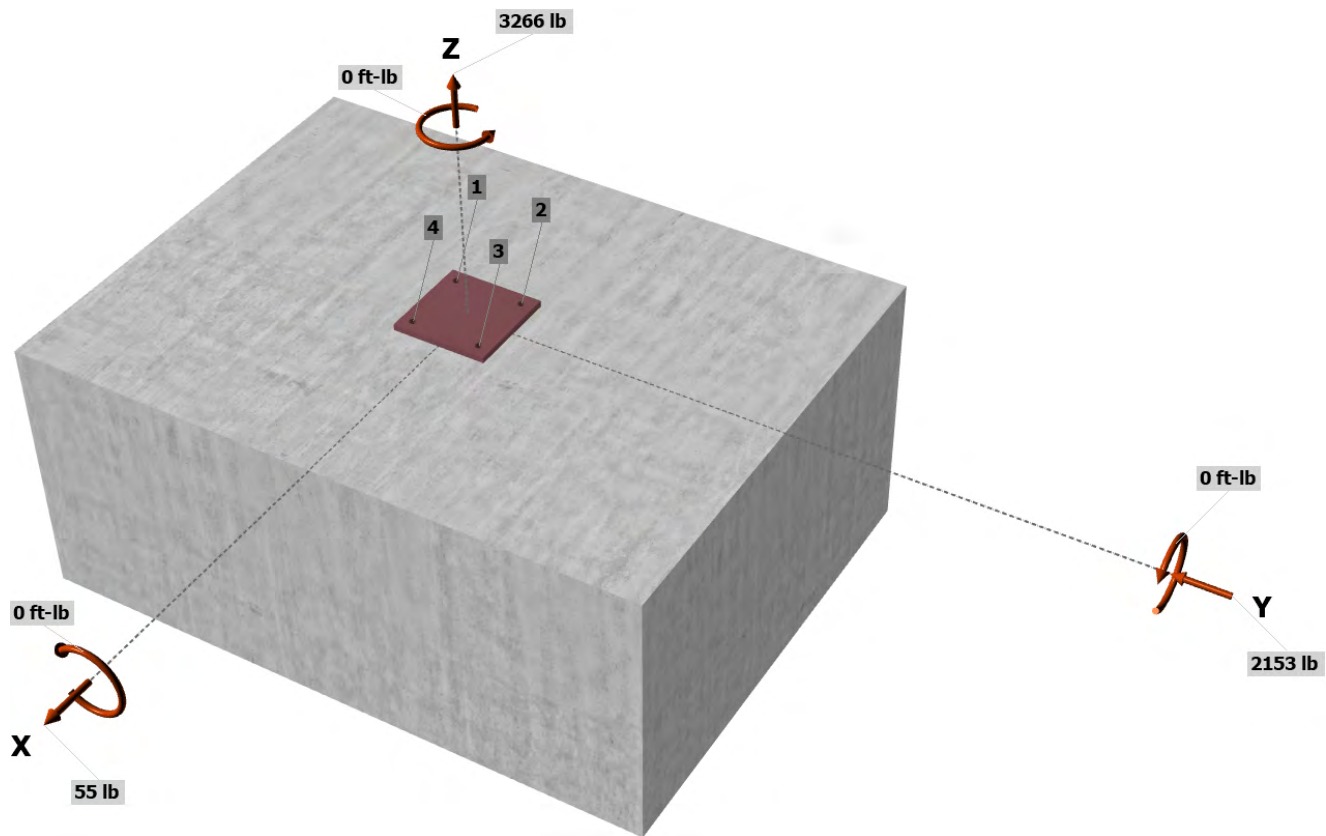

Company:		Date:	5/14/2018
Engineer:		Page:	3/6
Project:			
Address:			
Phone:			
E-mail:			

<Figure 2>

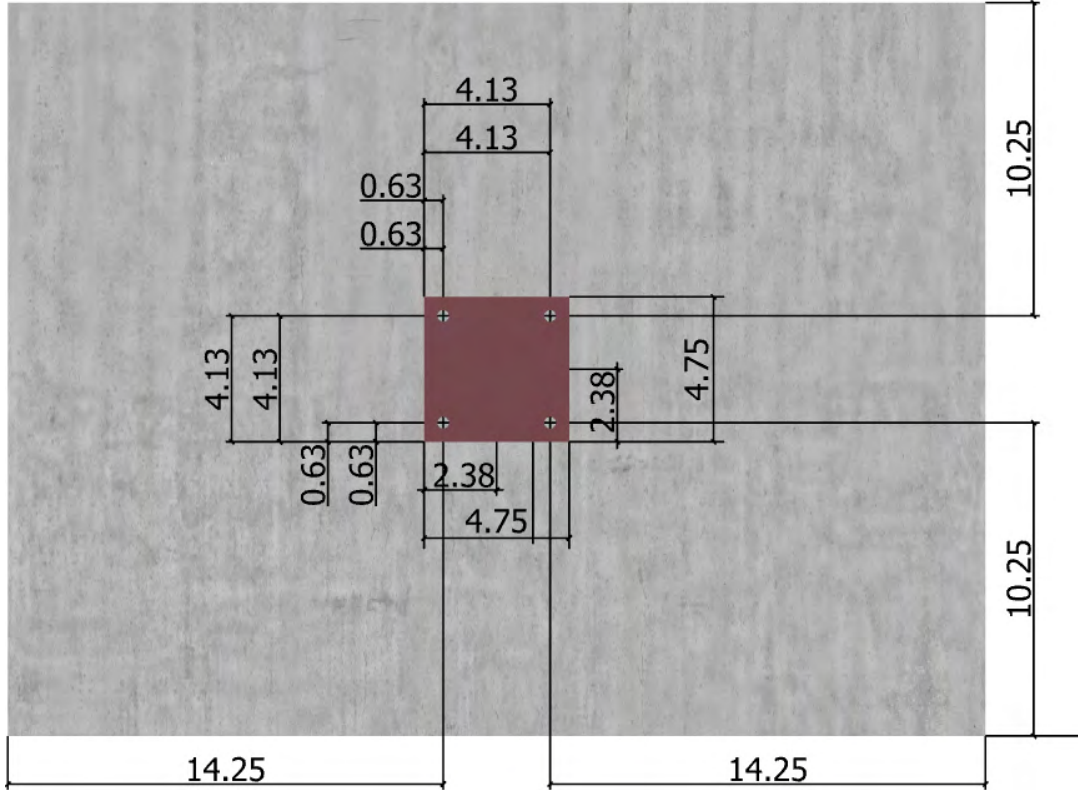



Company:		Date:	5/14/2018
Engineer:		Page:	4/6
Project:			
Address:			
Phone:			
E-mail:			

3. Resulting Anchor Forces

Anchor	Tension load, N _{ua} (lb)	Shear load x, V _{uax} (lb)	Shear load y, V _{uay} (lb)	Shear load combined, $\sqrt{(V_{uax})^2 + (V_{uay})^2}$ (lb)
1	816.5	13.8	-538.3	538.5
2	816.5	13.7	-538.3	538.5
3	816.5	13.7	-538.2	538.4
4	816.5	13.8	-538.2	538.4
Sum	3266.0	55.0	-2153.0	2153.7

Maximum concrete compression strain (%): 0.00
 Maximum concrete compression stress (psi): 0
 Resultant tension force (lb): 3266
 Resultant compression force (lb): 0
 Eccentricity of resultant tension forces in x-axis, e'_{Nx} (inch): 0.00
 Eccentricity of resultant tension forces in y-axis, e'_{Ny} (inch): 0.00
 Eccentricity of resultant shear forces in x-axis, e'_{Vx} (inch): 0.00
 Eccentricity of resultant shear forces in y-axis, e'_{Vy} (inch): 0.00

<Figure 3>

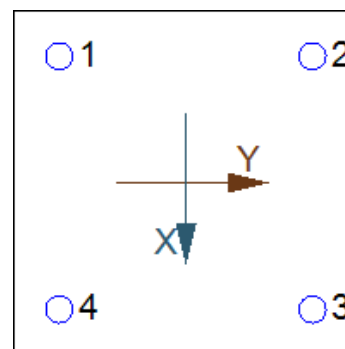

4. Steel Strength of Anchor in Tension (Sec. 17.4.1)

N _{sa} (lb)	φ	φN _{sa} (lb)
4525	0.75	3394

5. Concrete Breakout Strength of Anchor in Tension (Sec. 17.4.2)

$$N_b = K_c \lambda_a \sqrt{f'_c} h_{ef}^{1.5} \text{ (Eq. 17.4.2.2a)}$$

K _c	λ _a	f' _c (psi)	h _{ef} (in)	N _b (lb)
17.0	1.00	2500	4.000	6800

$$\phi N_{cbg} = \phi (A_{Nc} / A_{Nco}) \psi_{ec,N} \psi_{ed,N} \psi_{c,N} \psi_{cp,N} N_b \text{ (Sec. 17.3.1 \& Eq. 17.4.2.1b)}$$

A _{Nc} (in ²)	A _{Nco} (in ²)	C _{a,min} (in)	ψ _{ec,N}	ψ _{ed,N}	ψ _{c,N}	ψ _{cp,N}	N _b (lb)	φ	φN _{cbg} (lb)
240.25	144.00	10.25	1.000	1.000	1.00	1.000	6800	0.65	7374

6. Adhesive Strength of Anchor in Tension (Sec. 17.4.5)

$$\tau_{k,cr} = \tau_{k,cr,short-term} K_{sat} (f'_c / 2,500)^0$$

τ _{k,cr} (psi)	f _{short-term}	K _{sat}	f' _c (psi)	n	τ _{k,cr} (psi)
1346	1.00	1.00	2500	0.24	1346

$$N_{ba} = \lambda_a \tau_{cr} \pi d_a h_{ef} \text{ (Eq. 17.4.5.2)}$$

λ _a	τ _{cr} (psi)	d _a (in)	h _{ef} (in)	N _{ba} (lb)
1.00	1346	0.38	4.000	6343

$$\phi N_{ag} = \phi (A_{Na} / A_{Na0}) \psi_{ec,Na} \psi_{ed,Na} \psi_{cp,Na} N_{ba} \text{ (Sec. 17.3.1 \& Eq. 17.4.5.1b)}$$

A _{Na} (in ²)	A _{Na0} (in ²)	C _{Na} (in)	C _{a,min} (in)	ψ _{ec,Na}	ψ _{ed,Na}	ψ _{cp,Na}	N _{ba} (lb)	φ	φN _{ag} (lb)
198.45	112.09	5.29	10.25	1.000	1.000	1.000	6343	0.55	6176



Company:		Date:	5/14/2018
Engineer:		Page:	5/6
Project:			
Address:			
Phone:			
E-mail:			

8. Steel Strength of Anchor in Shear (Sec. 17.5.1)

V_{sa} (lb)	ϕ_{grout}	ϕ	$\phi_{grout}\phi V_{sa}$ (lb)
2715	1.0	0.65	1765

9. Concrete Breakout Strength of Anchor in Shear (Sec. 17.5.2)

Shear perpendicular to edge in x-direction:

$V_{bx} = \min|7(l_e / d_a)^{0.2} \sqrt{d_a} \lambda_a \sqrt{f_c} c_{a1}^{1.5}; 9 \lambda_a \sqrt{f_c} c_{a1}^{1.5}|$ (Eq. 17.5.2.2a & Eq. 17.5.2.2b)

l_e (in)	d_a (in)	λ_a	f_c (psi)	c_{a1} (in)	V_{bx} (lb)
3.00	0.375	1.00	2500	13.75	16564

$\phi V_{cbgx} = \phi (A_{vc} / A_{vco}) \Psi_{ec,v} \Psi_{ed,v} \Psi_{c,v} \Psi_{h,v} V_{bx}$ (Sec. 17.3.1 & Eq. 17.5.2.1b)

A_{vc} (in ²)	A_{vco} (in ²)	$\Psi_{ec,v}$	$\Psi_{ed,v}$	$\Psi_{c,v}$	$\Psi_{h,v}$	V_{bx} (lb)	ϕ	ϕV_{cbgx} (lb)
660.00	850.78	1.000	0.907	1.000	1.000	16564	0.70	8159

Shear perpendicular to edge in y-direction:

$V_{by} = \min|7(l_e / d_a)^{0.2} \sqrt{d_a} \lambda_a \sqrt{f_c} c_{a1}^{1.5}; 9 \lambda_a \sqrt{f_c} c_{a1}^{1.5}|$ (Eq. 17.5.2.2a & Eq. 17.5.2.2b)

l_e (in)	d_a (in)	λ_a	f_c (psi)	c_{a1} (in)	V_{by} (lb)
3.00	0.375	1.00	2500	16.00	20791

$\phi V_{cbgy} = \phi (A_{vc} / A_{vco}) \Psi_{ec,v} \Psi_{ed,v} \Psi_{c,v} \Psi_{h,v} V_{by}$ (Sec. 17.3.1 & Eq. 17.5.2.1b)

A_{vc} (in ²)	A_{vco} (in ²)	$\Psi_{ec,v}$	$\Psi_{ed,v}$	$\Psi_{c,v}$	$\Psi_{h,v}$	V_{by} (lb)	ϕ	ϕV_{cbgy} (lb)
576.00	1152.00	1.000	0.828	1.000	1.000	20791	0.70	6026

Shear parallel to edge in y-direction:

$V_{bx} = \min|7(l_e / d_a)^{0.2} \sqrt{d_a} \lambda_a \sqrt{f_c} c_{a1}^{1.5}; 9 \lambda_a \sqrt{f_c} c_{a1}^{1.5}|$ (Eq. 17.5.2.2a & Eq. 17.5.2.2b)

l_e (in)	d_a (in)	λ_a	f_c (psi)	c_{a1} (in)	V_{bx} (lb)
3.00	0.375	1.00	2500	14.25	17475

$\phi V_{cbgy} = \phi (2)(A_{vc} / A_{vco}) \Psi_{ec,v} \Psi_{ed,v} \Psi_{c,v} \Psi_{h,v} V_{bx}$ (Sec. 17.3.1, 17.5.2.1(c) & Eq. 17.5.2.1b)

A_{vc} (in ²)	A_{vco} (in ²)	$\Psi_{ec,v}$	$\Psi_{ed,v}$	$\Psi_{c,v}$	$\Psi_{h,v}$	V_{bx} (lb)	ϕ	ϕV_{cbgy} (lb)
513.00	913.78	1.000	1.000	1.000	1.000	17475	0.70	13735

Shear parallel to edge in x-direction:

$V_{by} = \min|7(l_e / d_a)^{0.2} \sqrt{d_a} \lambda_a \sqrt{f_c} c_{a1}^{1.5}; 9 \lambda_a \sqrt{f_c} c_{a1}^{1.5}|$ (Eq. 17.5.2.2a & Eq. 17.5.2.2b)

l_e (in)	d_a (in)	λ_a	f_c (psi)	c_{a1} (in)	V_{by} (lb)
3.00	0.375	1.00	2500	10.25	10661

$\phi V_{cbgx} = \phi (2)(A_{vc} / A_{vco}) \Psi_{ec,v} \Psi_{ed,v} \Psi_{c,v} \Psi_{h,v} V_{by}$ (Sec. 17.3.1, 17.5.2.1(c) & Eq. 17.5.2.1b)

A_{vc} (in ²)	A_{vco} (in ²)	$\Psi_{ec,v}$	$\Psi_{ed,v}$	$\Psi_{c,v}$	$\Psi_{h,v}$	V_{by} (lb)	ϕ	ϕV_{cbgx} (lb)
492.00	472.78	1.000	1.000	1.000	1.000	10661	0.70	15532

10. Concrete Pryout Strength of Anchor in Shear (Sec. 17.5.3)

$\phi V_{cp} = \phi \min|k_{cp} N_{ba}; k_{cp} N_{cb}| = \phi \min|k_{cp} (A_{Na} / A_{Na0}) \Psi_{ec,Na} \Psi_{ed,Na} \Psi_{c,Na} N_{ba}; k_{cp} (A_{Nc} / A_{Nco}) \Psi_{ec,N} \Psi_{ed,N} \Psi_{c,N} \Psi_{cp,N} N_b|$ (Sec. 17.3.1 & Eq. 17.5.3.1b)

k_{cp}	A_{Na} (in ²)	A_{Na0} (in ²)	$\Psi_{ed,Na}$	$\Psi_{ec,Na}$	$\Psi_{c,Na}$	N_{ba} (lb)	N_a (lb)
2.0	198.45	112.09	1.000	1.000	1.000	6343	11229

A_{Nc} (in ²)	A_{Nco} (in ²)	$\Psi_{ec,N}$	$\Psi_{ed,N}$	$\Psi_{c,N}$	$\Psi_{cp,N}$	N_b (lb)	N_{cb} (lb)	ϕ
240.25	144.00	1.000	1.000	1.000	1.000	6800	11345	0.70

Input data and results must be checked for agreement with the existing circumstances, the standards and guidelines must be checked for plausibility.



Company:		Date:	5/14/2018
Engineer:		Page:	6/6
Project:			
Address:			
Phone:			
E-mail:			

ϕV_{cpg} (lb)
15721

11. Results

Interaction of Tensile and Shear Forces (Sec. 17.6.)

Tension	Factored Load, N_{ua} (lb)	Design Strength, ϕN_n (lb)	Ratio	Status	
Steel	817	3394	0.24	Pass	
Concrete breakout	3266	7374	0.44	Pass	
Adhesive	3266	6176	0.53	Pass (Governs)	
Shear	Factored Load, V_{ua} (lb)	Design Strength, ϕV_n (lb)	Ratio	Status	
Steel	538	1765	0.31	Pass	
T Concrete breakout x+	55	8159	0.01	Pass	
T Concrete breakout y-	2153	6026	0.36	Pass	
Concrete breakout y-	28	13735	0.00	Pass	
Concrete breakout x-	1077	15532	0.07	Pass	
Concrete breakout, combined	-	-	0.36	Pass (Governs)	
Pryout	2154	15721	0.14	Pass	
Interaction check	$N_{ua}/\phi N_n$	$V_{ua}/\phi V_n$	Combined Ratio	Permissible	Status
Sec. 17.6..1	0.53	0.00	52.9%	1.0	Pass

SET-3G w/ 3/8"Ø F1554 Gr. 36 with hef = 4.000 inch meets the selected design criteria.

12. Warnings

- Designer must exercise own judgement to determine if this design is suitable.
- Refer to manufacturer's product literature for hole cleaning and installation instructions.

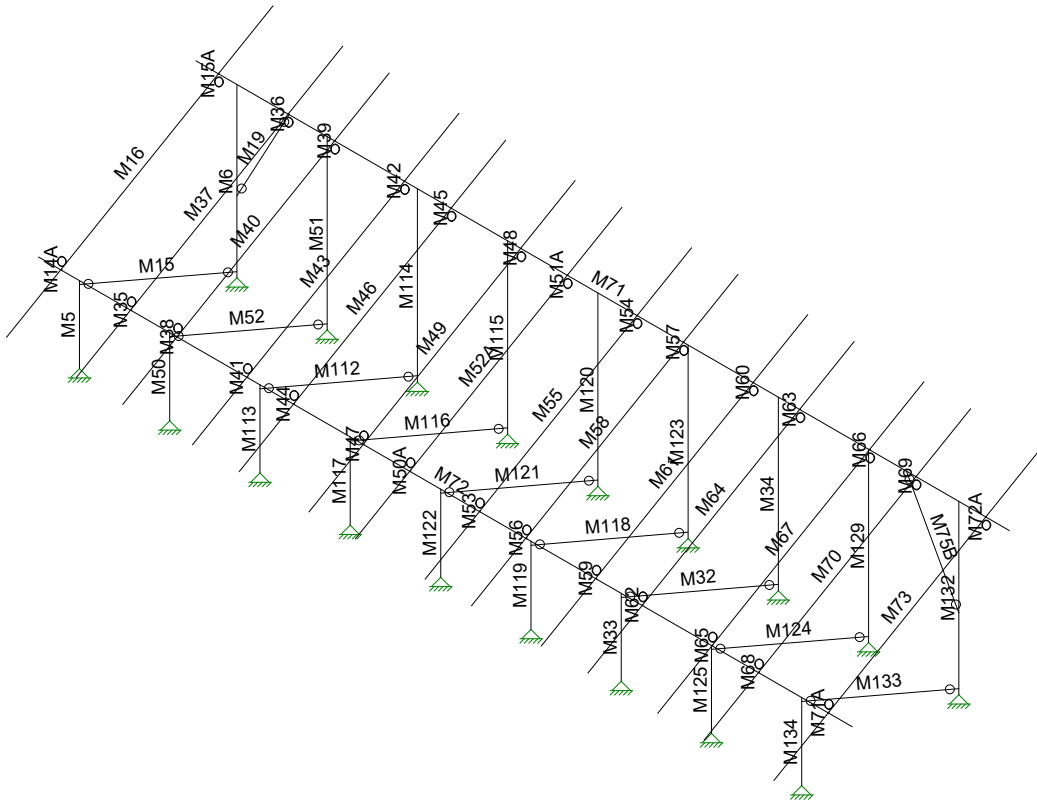

Envelope Only Solution

Vector Structural Engineeri...

STB

U2716.0319.211

Sunturf Ground Mount B6 (85x45)

SK - 1

Aug 17, 2021 at 10:59 AM

Sunturf Ground Mount B6 85x45.r3d

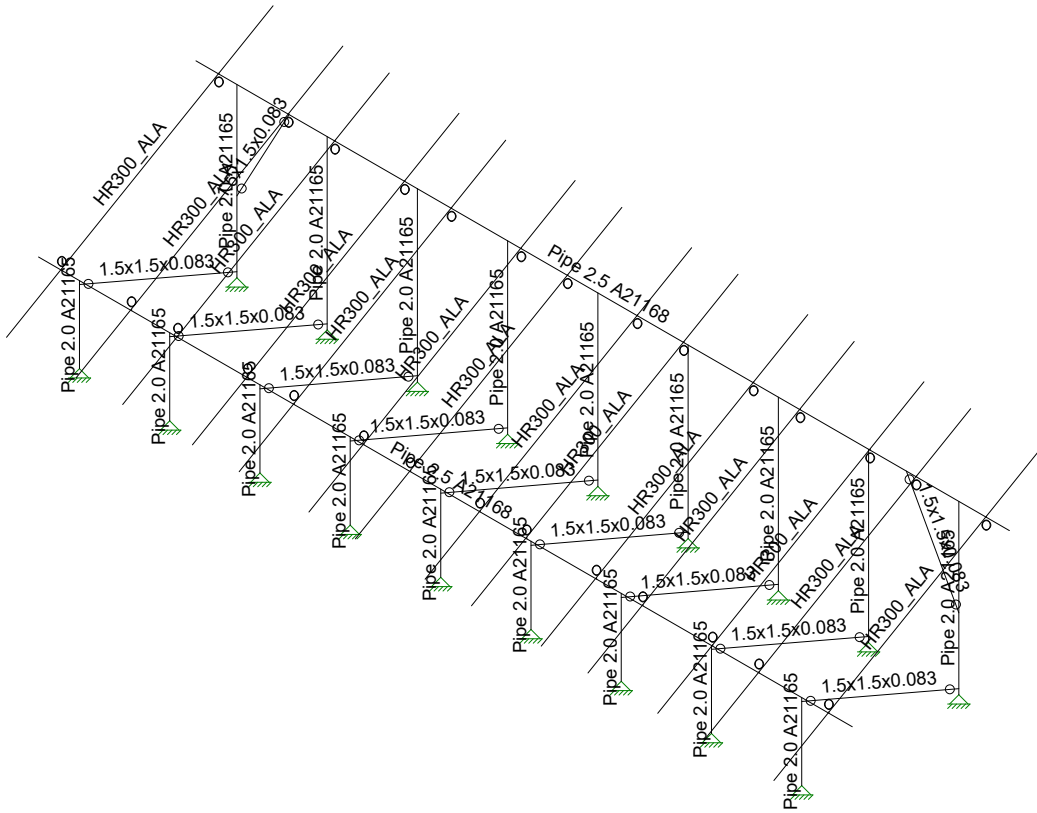

Envelope Only Solution

Vector Structural Engineeri...

STB

U2716.0319.211

Sunturf Ground Mount B6 (85x45)

SK - 2

Aug 17, 2021 at 10:59 AM

Sunturf Ground Mount B6 85x45.r3d

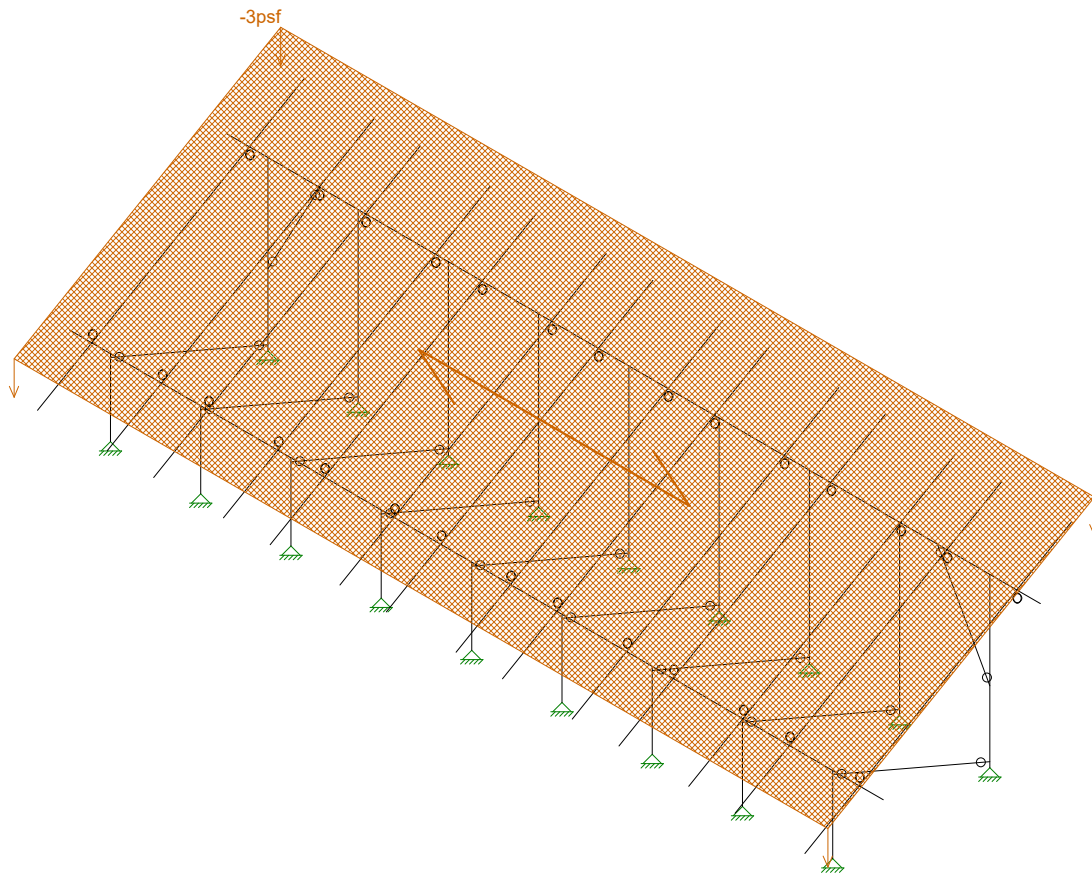

Loads: BLC 2, Solar Panel Weight
Envelope Only Solution

Vector Structural Engineeri..	Sunturf Ground Mount B6 (85x45)	SK - 3
STB		Aug 17, 2021 at 10:59 AM
U2716.0319.211		Sunturf Ground Mount B6 85x45.r3d

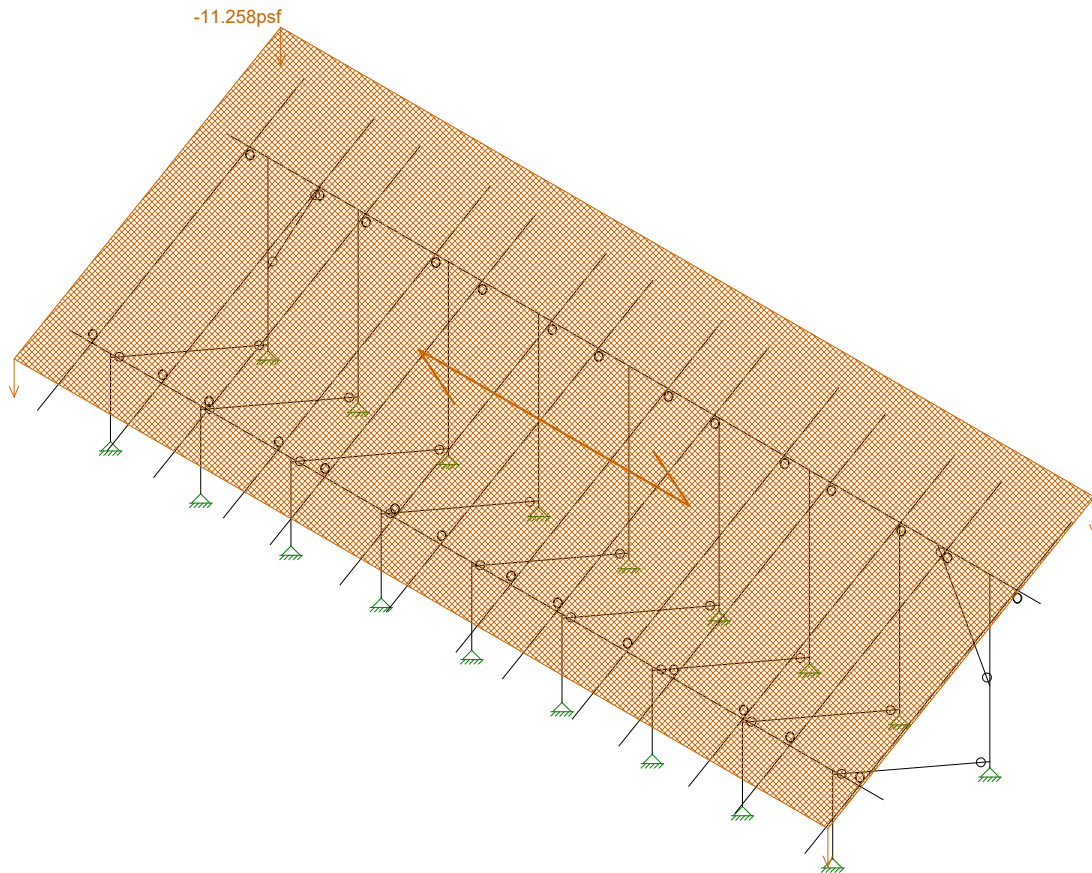

Loads: BLC 3, Roof Live/Snow
Envelope Only Solution

Vector Structural Engineeri..	Sunturf Ground Mount B6 (85x45)	SK - 4
STB		Aug 17, 2021 at 10:59 AM
U2716.0319.211		Sunturf Ground Mount B6 85x45.r3d

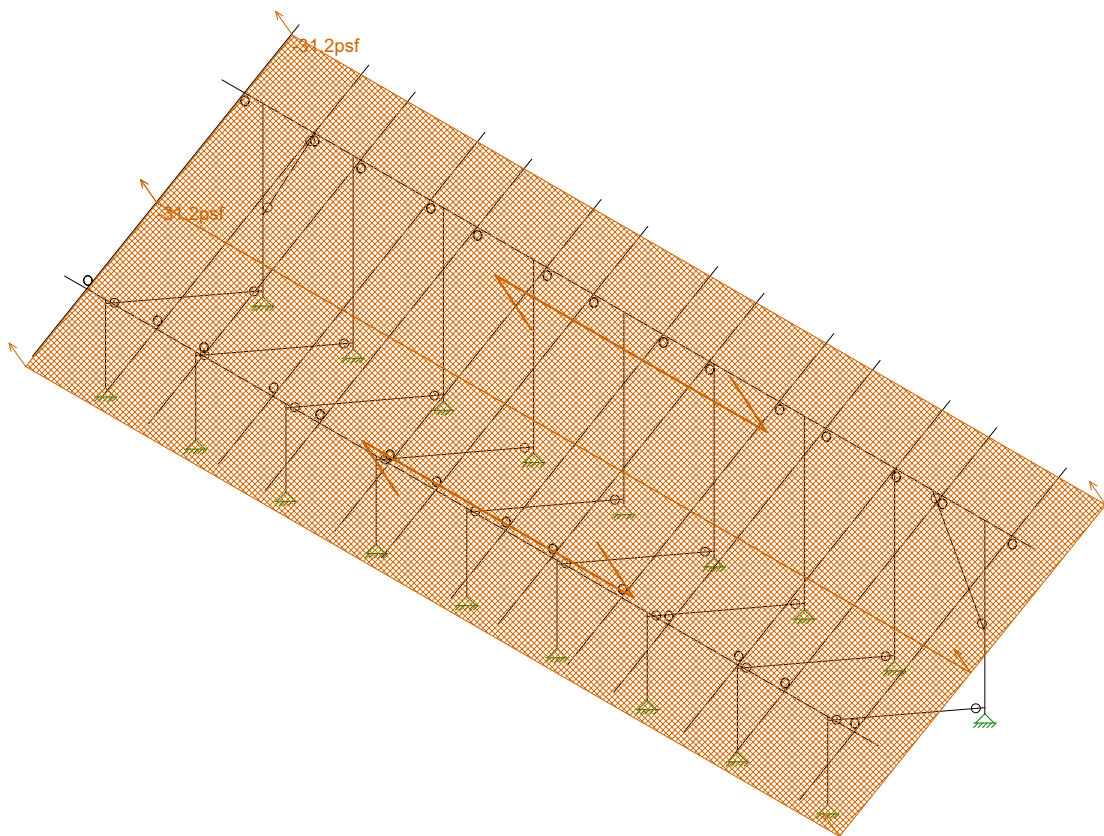

Loads: BLC 4, Wind A 0 deg
Envelope Only Solution

Vector Structural Engineeri..	Sunturf Ground Mount B6 (85x45)	SK - 5
STB		Aug 17, 2021 at 10:59 AM
U2716.0319.211		Sunturf Ground Mount B6 85x45.r3d

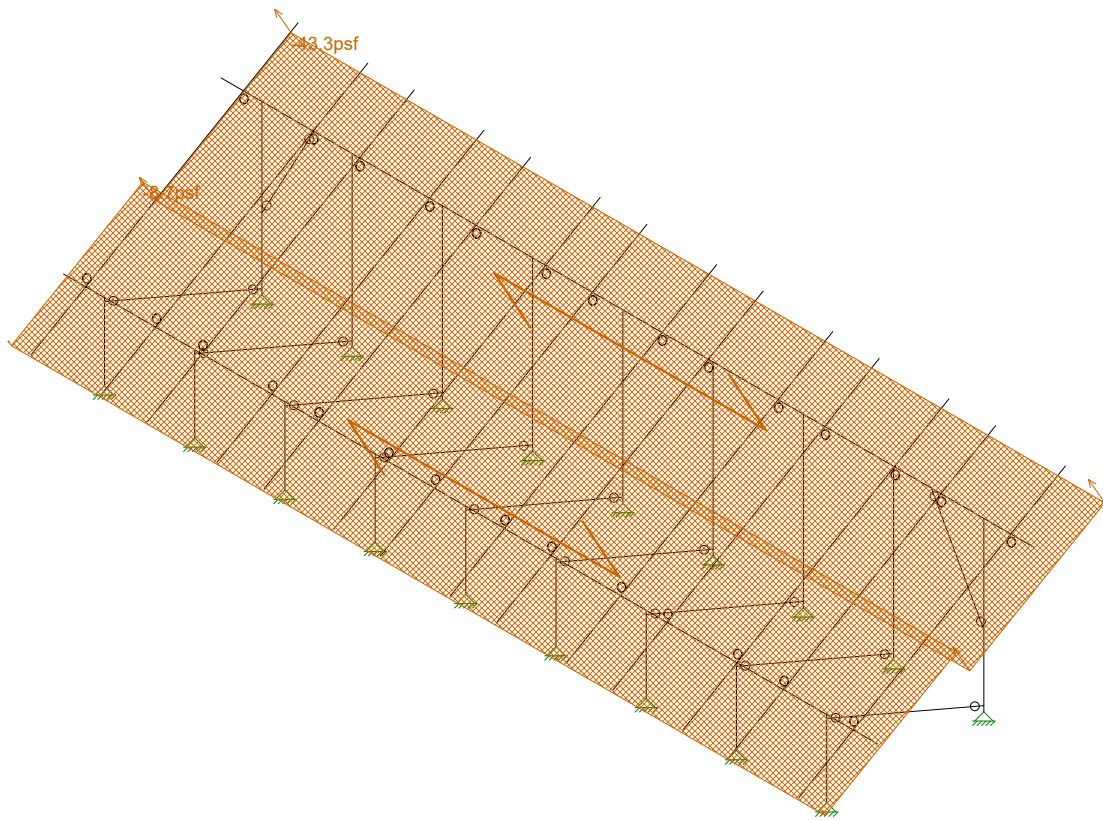

Loads: BLC 5, Wind B 0 deg
Envelope Only Solution

Vector Structural Engineeri...
STB
U2716.0319.211

Sunturf Ground Mount B6 (85x45)

SK - 6

Aug 17, 2021 at 10:59 AM
Sunturf Ground Mount B6 85x45.r3d

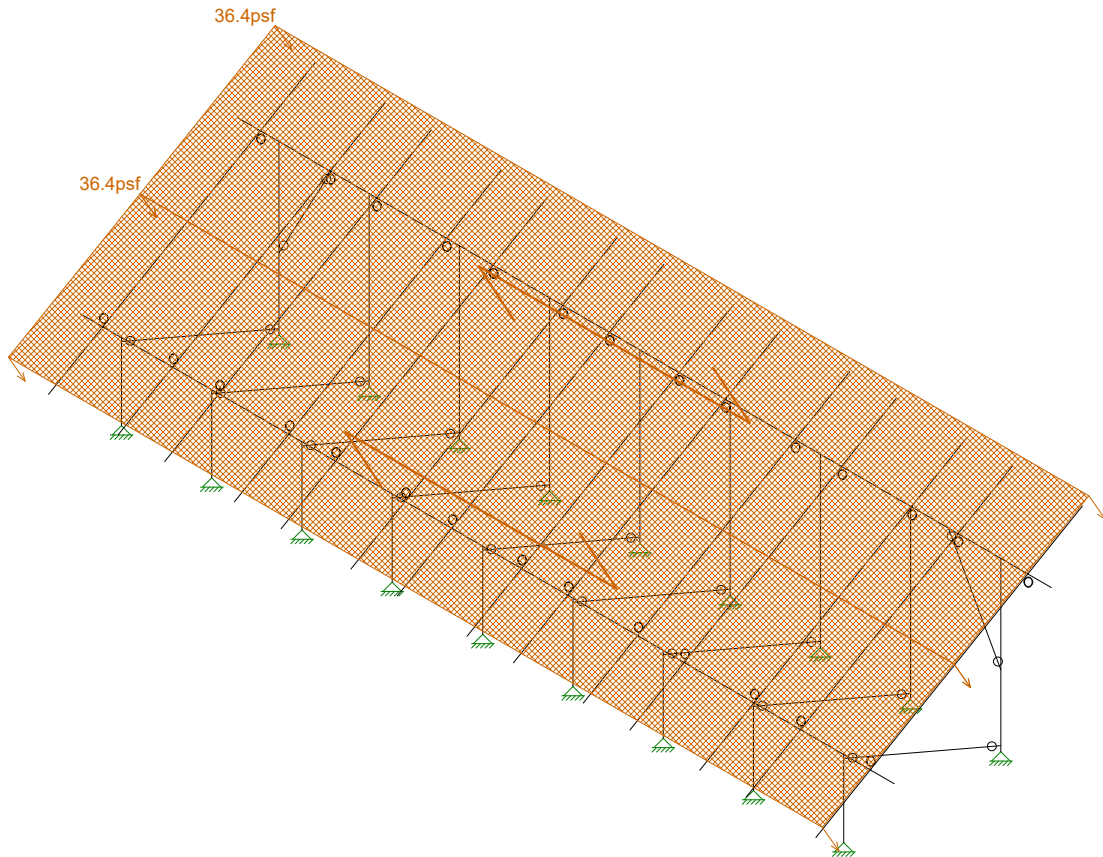

Loads: BLC 6, Wind A 180 deg
Envelope Only Solution

Vector Structural Engineeri...
STB
U2716.0319.211

Sunturf Ground Mount B6 (85x45)

SK - 7

Aug 17, 2021 at 10:59 AM
Sunturf Ground Mount B6 85x45.r3d

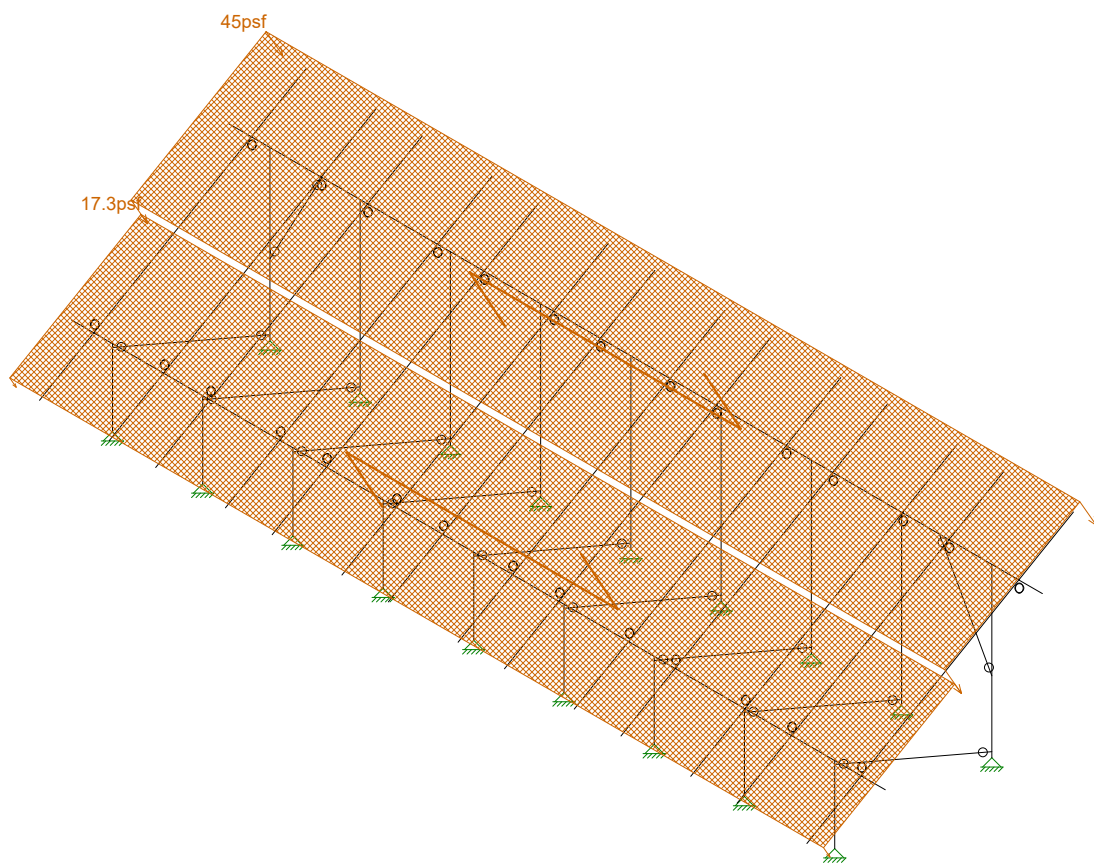

Loads: BLC 7, Wind B 180 deg
Envelope Only Solution

Vector Structural Engineeri..	Sunturf Ground Mount B6 (85x45)	SK - 8
STB		Aug 17, 2021 at 11:00 AM
U2716.0319.211		Sunturf Ground Mount B6 85x45.r3d



Code Check (Env)	
Black	No Calc
Red	> 1.0
Magenta	.90-1.0
Green	.75-.90
Cyan	.50-.75
Blue	0-.50

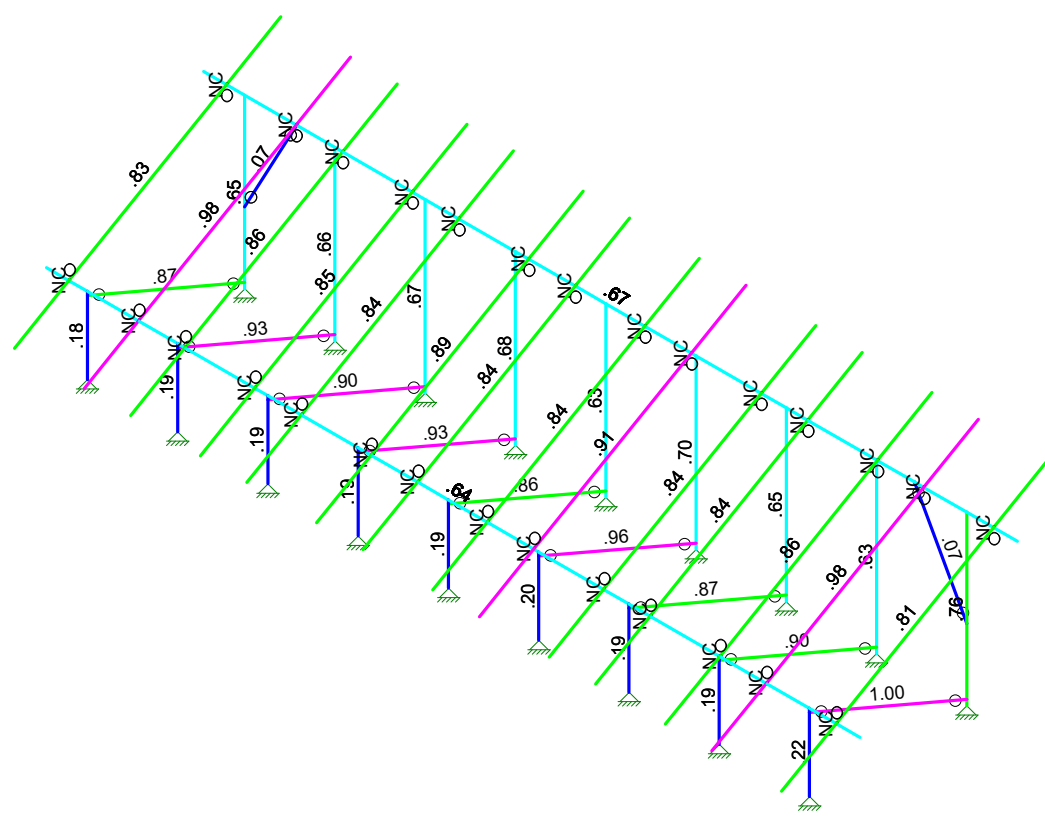

Member Code Checks Displayed (Enveloped)
Envelope Only Solution

Vector Structural Engineeri...	Sunturf Ground Mount B6 (85x45)	SK - 9
STB		Aug 17, 2021 at 11:00 AM
U2716.0319.211		Sunturf Ground Mount B6 85x45.r3d



Shear Check
(Env)

- No Calc
- > 1.0
- .90-1.0
- .75-.90
- .50-.75
- 0-.50

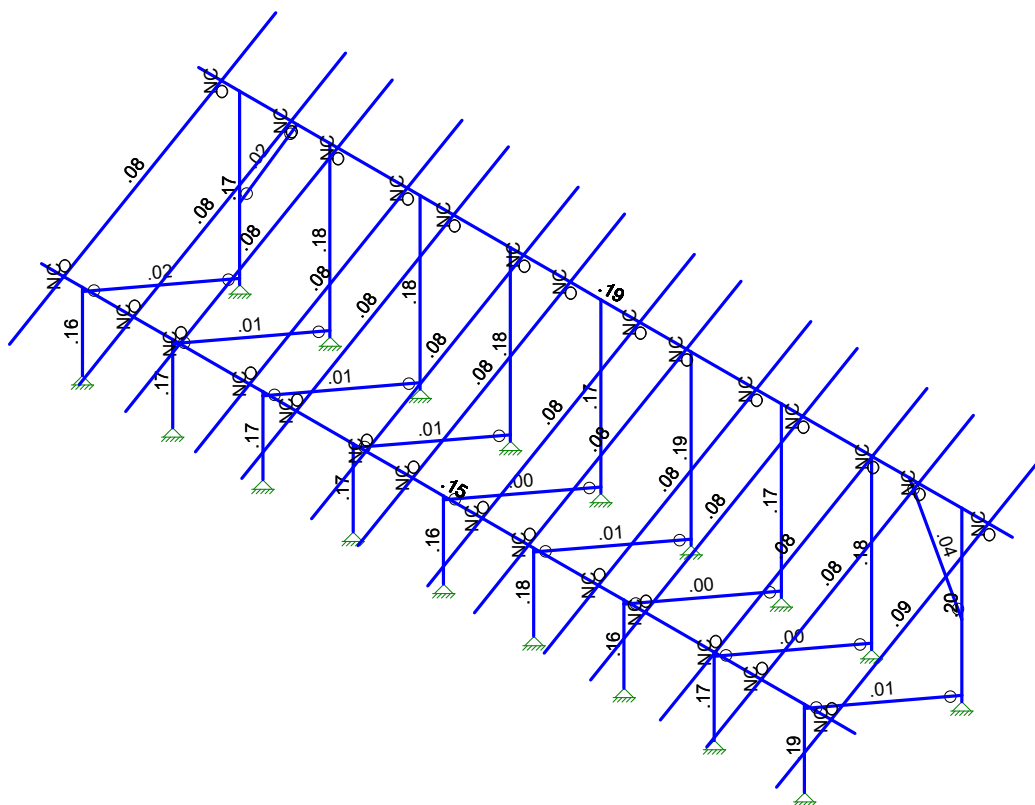

Member Shear Checks Displayed (Enveloped)
Envelope Only Solution

Vector Structural Engineeri...	Sunturf Ground Mount B6 (85x45)	SK - 10
STB		Aug 17, 2021 at 11:03 AM
U2716.0319.211		Sunturf Ground Mount B6 85x45.r3d



Company : Vector Structural Engineering
 Designer : STB
 Job Number : U2716.0319.211
 Model Name : Sunturf Ground Mount B6 (85x45)

Aug 17, 2021
 11:03 AM
 Checked By: _____

(Global) Model Settings

Display Sections for Member Calcs	5
Max Internal Sections for Member Calcs	97
Include Shear Deformation?	Yes
Increase Nailing Capacity for Wind?	Yes
Include Warping?	Yes
Trans Load Btwn Intersecting Wood Wall?	Yes
Area Load Mesh (in^2)	144
Merge Tolerance (in)	.12
P-Delta Analysis Tolerance	0.50%
Include P-Delta for Walls?	Yes
Automatically Iterate Stiffness for Walls?	Yes
Max Iterations for Wall Stiffness	3
Gravity Acceleration (in/sec^2)	386.4
Wall Mesh Size (in)	24
Eigensolution Convergence Tol. (1.E-)	4
Vertical Axis	Y
Global Member Orientation Plane	XZ
Static Solver	Sparse Accelerated
Dynamic Solver	Accelerated Solver

Hot Rolled Steel Code	AISC 14th(360-10): ASD
Adjust Stiffness?	Yes(Iterative)
RISACONNECTION CODE	AISC 14th(360-10): ASD
Cold Formed Steel Code	AISI S100-12: ASD
Wood Code	AWC NDS-15: ASD
Wood Temperature	< 100F
Concrete Code	ACI 318-14
Masonry Code	ACI 530-13: ASD
Aluminum Code	AA ADM1-15: ASD - Building
Stainless Steel Code	AISC 14th(360-10): ASD
Adjust Stiffness?	Yes(Iterative)

Number of Shear Regions	4
Region Spacing Increment (in)	4
Biaxial Column Method	Exact Integration
Parame Beta Factor (PCA)	.65
Concrete Stress Block	Rectangular
Use Cracked Sections?	No
Use Cracked Sections Slab?	No
Bad Framing Warnings?	No
Unused Force Warnings?	Yes
Min 1 Bar Diam. Spacing?	No
Concrete Rebar Set	REBAR SET ASTMA615
Min % Steel for Column	1
Max % Steel for Column	8

(Global) Model Settings, Continued

Seismic Code	ASCE 7-10
Seismic Base Elevation (in)	15600
Add Base Weight?	Yes
Ct X	.02
Ct Z	.02
T X (sec)	Not Entered
T Z (sec)	Not Entered
R X	3
R Z	3
Ct Exp. X	.75
Ct Exp. Z	.75
SD1	1
SDS	1
S1	1
TL (sec)	5
Risk Cat	I or II
Drift Cat	Other
Om Z	1
Om X	1
Cd Z	4
Cd X	4
Rho Z	1
Rho X	1

Hot Rolled Steel Properties

	Label	E [ksi]	G [ksi]	Nu	Therm (/1E5 F)	Density[lb/ft^3]	Yield[psi]	Ry	Fu[psi]	Rt
1	A992	29000	11154	.3	.65	490	50000	1.1	65000	1.1
2	A36 Gr.36	29000	11154	.3	.65	490	36000	1.5	58000	1.2
3	A572 Gr.50	29000	11154	.3	.65	490	50000	1.1	65000	1.1
4	A500 Gr.B R...	29000	11154	.3	.65	527	42000	1.4	58000	1.3
5	A500 Gr.B Re...	29000	11154	.3	.65	527	46000	1.4	58000	1.3
6	A53 Gr.B	29000	11154	.3	.65	490	35000	1.6	60000	1.2
7	A1085	29000	11154	.3	.65	490	50000	1.4	65000	1.3

Aluminum Properties

	Label	E [ksi]	G [ksi]	Nu	Therm (...Density[... Table B.4	kt	Ftu[psi]	Fty[psi]	Fcy[psi]	Fsu[psi]	Ct
1	3003-H14	10100	3787.5	.33	1.3 172.8 Table B.4-1	1	19000	16000	13000	12000	141
2	6061-T6	10100	3787.5	.33	1.3 172.8 Table B.4-2	1	38000	35000	35000	24000	141
3	6063-T5	10100	3787.5	.33	1.3 172.8 Table B.4-2	1	22000	16000	16000	13000	141
4	6063-T6	10100	3787.5	.33	1.3 172.8 Table B.4-2	1	30000	25000	25000	19000	141
5	5052-H34	10200	3787.5	.33	1.3 172.8 Table B.4-1	1	34000	26000	24000	20000	141
6	6061-T6 W	10100	3787.5	.33	1.3 172.8 Table B.4-1	1	24000	15000	15000	15000	141
7	6005-T5	10100	3787.5	.33	1.3 172.8 Table B.4-1	1	38000	35000	35000	24000	141

Hot Rolled Steel Section Sets

	Label	Shape	Type	Design List	Material	Design R...	A [in2]	Iyy [in4]	Izz [in4]	J [in4]
1	Post	Pipe 2.0 A21165	Column	Pipe	A572 Gr.50	Typical	.776	.499	.499	.998
2	Cross Beam	Pipe 2.5 A21168	Beam	Wide Flange	A572 Gr.50	Typical	.947	.907	.907	1.814
3	Diagonal Brace	1.5x1.5x0.083	HBrace	SquareTube	A572 Gr.50	Typical	.47	.158	.158	.236



Company : Vector Structural Engineering
 Designer : STB
 Job Number : U2716.0319.211
 Model Name : Sunturf Ground Mount B6 (85x45)

Aug 17, 2021
 11:03 AM
 Checked By: _____

Aluminum Section Sets

	Label	Shape	Type	Design List	Material	Design R...	A [in2]	Iyy [in4]	Izz [in4]	J [in4]
1	AL Posts	2.375ODX0.188	Column	Pipe	6005-T5	Typical	1.29	.778	.778	1.54
2	AL Brace	RT1.5x2x0.15625	VBrace	Rectangular Tubes	6005-T5	Typical	.996	.327	.524	.602
3	AL Rails	HR300 ALA	Beam	Rectangular Tubes	6005-T5	Typical	.736	.214	.727	.734
4	AL Cross Beam	Cross Rail	Beam	Rectangular Tubes	6005-T5	Typical	1.909	1.97	4.366	4.017

Member Area Loads (BLC 2 : Solar Panel Weight)

	Joint A	Joint B	Joint C	Joint D	Direction	Distribution	Magnitude[psf]
1	N197	N200	N199	N196	Y	A-B	-3

Member Area Loads (BLC 3 : Roof Live/Snow)

	Joint A	Joint B	Joint C	Joint D	Direction	Distribution	Magnitude[psf]
1	N197	N200	N199	N196	PY	A-B	-13

Member Area Loads (BLC 4 : Wind A 0 deg)

	Joint A	Joint B	Joint C	Joint D	Direction	Distribution	Magnitude[psf]
1	N197	N200	N201	N198	Perp	A-B	-31.2
2	N198	N201	N199	N196	Perp	A-B	-31.2

Member Area Loads (BLC 5 : Wind B 0 deg)

	Joint A	Joint B	Joint C	Joint D	Direction	Distribution	Magnitude[psf]
1	N197	N200	N201	N198	Perp	A-B	-43.3
2	N198	N201	N199	N196	Perp	A-B	-8.7

Member Area Loads (BLC 6 : Wind A 180 deg)

	Joint A	Joint B	Joint C	Joint D	Direction	Distribution	Magnitude[psf]
1	N197	N200	N201	N198	Perp	A-B	36.4
2	N198	N201	N199	N196	Perp	A-B	36.4

Member Area Loads (BLC 7 : Wind B 180 deg)

	Joint A	Joint B	Joint C	Joint D	Direction	Distribution	Magnitude[psf]
1	N197	N200	N201	N198	Perp	A-B	45
2	N198	N201	N199	N196	Perp	A-B	17.3

Basic Load Cases

	BLC Description	Category	X Gravity	Y Gravity	Z Gravity	Joint	Point	Distributed	Area(M...Surface...
1	Self Weight	DL		-1.05					
2	Solar Panel Weight	DL							1
3	Roof Live/Snow	RLL							1
4	Wind A 0 deg	OL1							2
5	Wind B 0 deg	OL2							2
6	Wind A 180 deg	OL3							2
7	Wind B 180 deg	OL4							2
8	BLC 2 Transient Area ...	None						46	
9	BLC 3 Transient Area ...	None						46	
10	BLC 4 Transient Area ...	None						120	
11	BLC 5 Transient Area ...	None						120	
12	BLC 6 Transient Area ...	None						120	
13	BLC 7 Transient Area ...	None						120	

Load Combinations

Table with columns: Description, S... PD..., SRSS, BLC Fa..., BLC Fa..., BLC Fa..., B..., B..., B..., B..., B..., B..., B..., B..., B..., B..., B..., B..., B..., B..., B..., B..., B..., B...

Envelope Joint Reactions

Table with columns: Joint, X [lb], LC, Y [lb], LC, Z [lb], LC, MX [lb-ft], LC MY [lb...], LC MZ [lb-ft], LC



Company : Vector Structural Engineering
 Designer : STB
 Job Number : U2716.0319.211
 Model Name : Sunturf Ground Mount B6 (85x45)

Aug 17, 2021
 11:03 AM
 Checked By: _____

Envelope AA ADM1-15: ASD - Building Aluminum Code Checks

Member	Shape	Code C...	Loc[in]	LC	Shear ...	Loc[in]	Dir	LC	Pnc/O...	Pnt/Om...	Mny/O...	Mnz/O...	Vny/O...	Vnz/O...	Cb	Eqn
1	M16	HR300_A...	.826	178.1...	13	.078	178.1...	y	7	2117.172	14342....	533.921	934.619	7307.692	3206.154	1...H.1-1
2	M37	HR300_A...	.974	110.1...	10	.081	178.1...	y	11	2117.172	14342....	533.921	934.619	7307.692	3206.154	1...H.1-1
3	M40	HR300_A...	.866	178.1...	13	.078	178.1...	y	11	2117.172	14342....	533.921	934.619	7307.692	3206.154	1...H.1-1
4	M43	HR300_A...	.852	178.1...	13	.078	178.1...	y	11	2117.172	14342....	533.921	934.619	7307.692	3206.154	1...H.1-1
5	M46	HR300_A...	.841	112.5	10	.077	178.1...	y	11	2117.172	14342....	533.921	934.619	7307.692	3206.154	1...H.1-1
6	M49	HR300_A...	.892	178.1...	13	.082	178.1...	y	11	2117.172	14342....	533.921	934.619	7307.692	3206.154	1...H.1-1
7	M52A	HR300_A...	.843	112.5	10	.080	178.1...	y	11	2117.172	14342....	533.921	934.619	7307.692	3206.154	1...H.1-1
8	M55	HR300_A...	.840	112.5	10	.078	178.1...	y	11	2117.172	14342....	533.921	934.619	7307.692	3206.154	1...H.1-1
9	M58	HR300_A...	.914	178.1...	13	.080	178.1...	y	11	2117.172	14342....	533.921	934.619	7307.692	3206.154	1...H.1-1
10	M61	HR300_A...	.843	112.5	10	.077	178.1...	y	11	2117.172	14342....	533.921	934.619	7307.692	3206.154	1...H.1-1
11	M64	HR300_A...	.843	112.5	10	.078	178.1...	y	11	2117.172	14342....	533.921	934.619	7307.692	3206.154	1...H.1-1
12	M67	HR300_A...	.861	178.1...	13	.077	178.1...	y	11	2117.172	14342....	533.921	934.619	7307.692	3206.154	1...H.1-1
13	M70	HR300_A...	.982	110.1...	10	.082	178.1...	y	11	2117.172	14342....	533.921	934.619	7307.692	3206.154	1...H.1-1
14	M73	HR300_A...	.814	178.1...	13	.088	178.1...	y	7	2117.172	14342....	533.921	934.619	7307.692	3206.154	1...H.1-1



JOB NO.: U2716.0319.211

PROJECT: Sunturf B6 Ground Mount

SUBJECT: CALCULATIONS

DESIGN APPROACH ASD

CONNECTION CAPACITY

Location: Column Base (set screws)

Connection Type: M16 Conical Set Screws

Tensile Capacity: 2603 lbs (AISC Equation J3-1)

Tension Load: 1944 lbs

Check Connection: 74.7%

Result: **Select M16 Conical Set Screws**

Note: Uplift capacity. FOS of (2)

CONNECTION CAPACITY

Location: Column to Cross Beam

Connection Type: K10341-002

Tensile Capacity: 2195 lbs

Tension Load: 1418 lbs

Check Connection: 64.6%

Result: **Select K10341-002**

Note: Uplift capacity. FOS of (2)



JOB NO.: U2716.0319.211

PROJECT: Sunturf B6 Ground Mount

SUBJECT: CALCULATIONS

CONNECTION CAPACITY

Location: Brace to Column

Connection Type: K10219-001

Capacity: 1483 lbs (AISC Equation J3-1)

Tension Load: 1464 lbs

Check Connection: 98.7%

Result: **Select K10219-001**

Note: Axial capacity. FOS of (1.8)

BOLTED TENSION CONNECTION

Location: Rail to Cross Beam

Bolt Grade: A304 SS (A2-70)

Bolt Diameter: 0.375 in

Number of Bolts: 2

Bolt Capacity: 8410 lbs (AISC Equation J3-1)

Tension Load: 873 lbs

Check Bolt: 10.4%

Result: **Select (2) 0.375 in. dia. A304 SS (A2-70) bolts.**

Note:
