



Project Number: U2716-094-191

August 30, 2021

Sunmodo
14800 NE 65th Street
Vancouver, WA 98682

**REFERENCE: Sunmodo Sunturf Ground Mount B1
Ground Mount PV Array Installation**

To Whom It May Concern:

Per request of Sunmodo, we have been asked to prepare the structural design of a ground-mounted PV solar array system with several foundation options as shown in the attached calculations. The adopted building code in this jurisdiction is the International Building Code, 2015 Edition. Vector Structural Engineering requires that we review each site specific install, and we are not liable for installs at site specific locations we have not reviewed. The following design parameters are used in our analysis:

- Minimum Design Loads for Buildings and Other Structures (ASCE 7-10)
- Design wind speed for risk category I structures: 105 mph
- Wind exposure: C
- Ground snow load: 30 psf
- The ground screws and helical piers must be tested to 1.5 times uplift and 2.0 times lateral reactions found in the table below. A minimum of one ground screw or helical pier must be tested.

Load (ASD)	Value (lbs)	Factor of Safety	Test Value (lbs)
UPLIFT	2400	1.5	3600
LATERAL	1710	2	3420

Foundation concrete shall have a minimum compressive strength of 2500 psi at 28 days. Cement for all concrete shall be Type I or II with a minimum of 6% entrained air with a water/cement ratio of 0.50. Maximum aggregate size shall be 3/4". No special inspection of concrete strength is required.

Footings are designed based on an allowable soil bearing pressure of 1500 psf an allowable skin friction of 250 psf, an allowable lateral bearing pressure of 150 pcf, and a coefficient of friction of 0.3. Vector Structural Engineering strongly recommends independent soils testing be performed by a licensed geotechnical engineer to verify the assumed soil parameters.

All ground mounts are to be installed per manufacturer’s recommendations. The use of solar panel support span tables provided by the manufacturer is allowed only where the site conditions and solar panel configuration match the description of the span tables. Electrical engineering is beyond our scope. All work performed must be in accordance with accepted industry-wide methods and applicable safety standards. Vector Structural Engineering assumes no responsibility for improper installation of the solar panels.

Very truly yours,

VECTOR STRUCTURAL ENGINEERING, LLC
KS Firm License: E-1647-COA

Coleman Larson, P.E.
License: 25629 - Expires: 04/30/2022
Project Engineer

Enclosures

CDL/mih



08/30/2021



JOB NO. U2716-094-191
 PROJECT SUNMODO SUNTURF GROUND MOUNTS B1
 SUBJECT ALL OPTIONS

651 W GALENA PARK BLVD. #101 (801) 990-1775
 DRAPER, UTAH 84020 (801) 990-1776 FAX

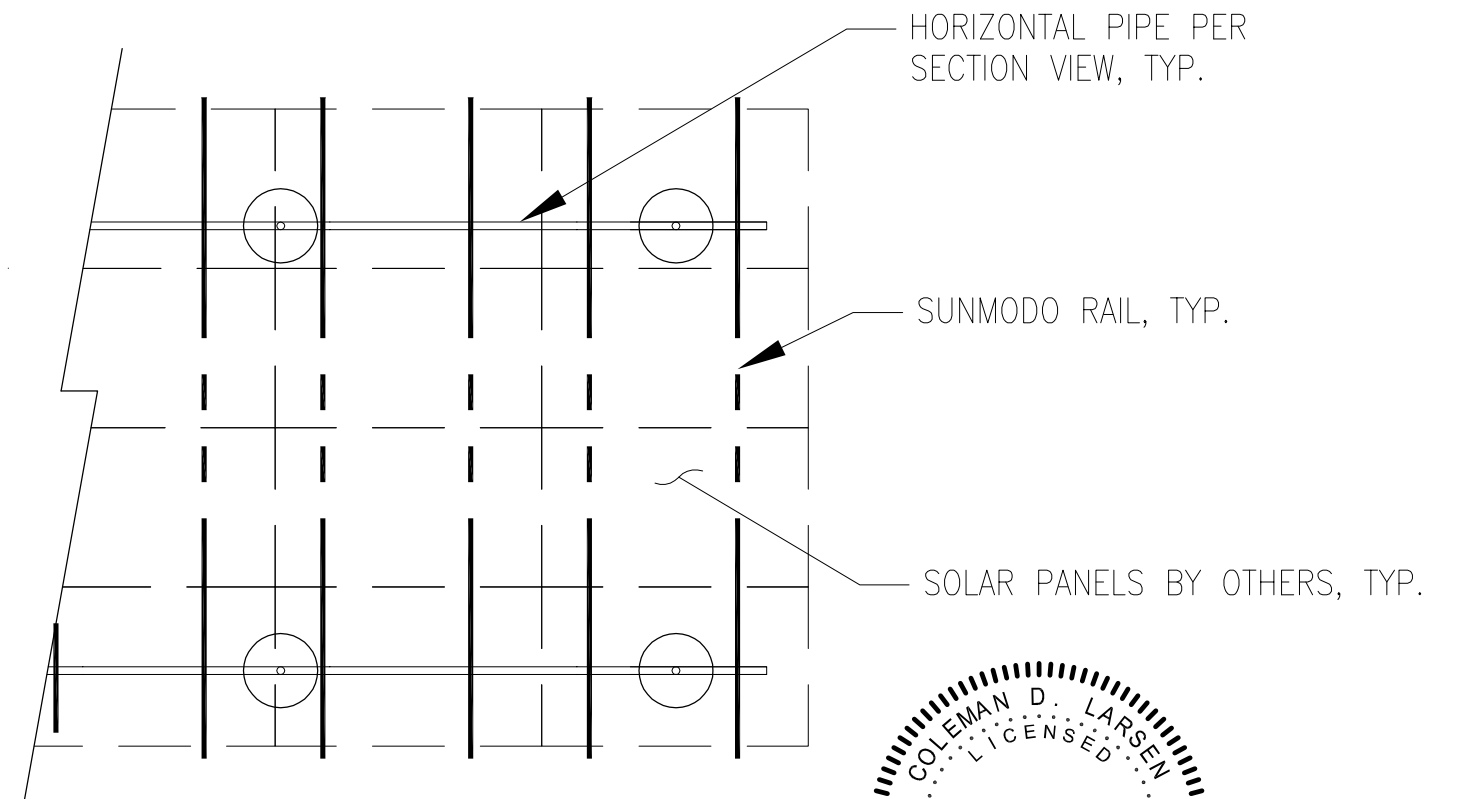
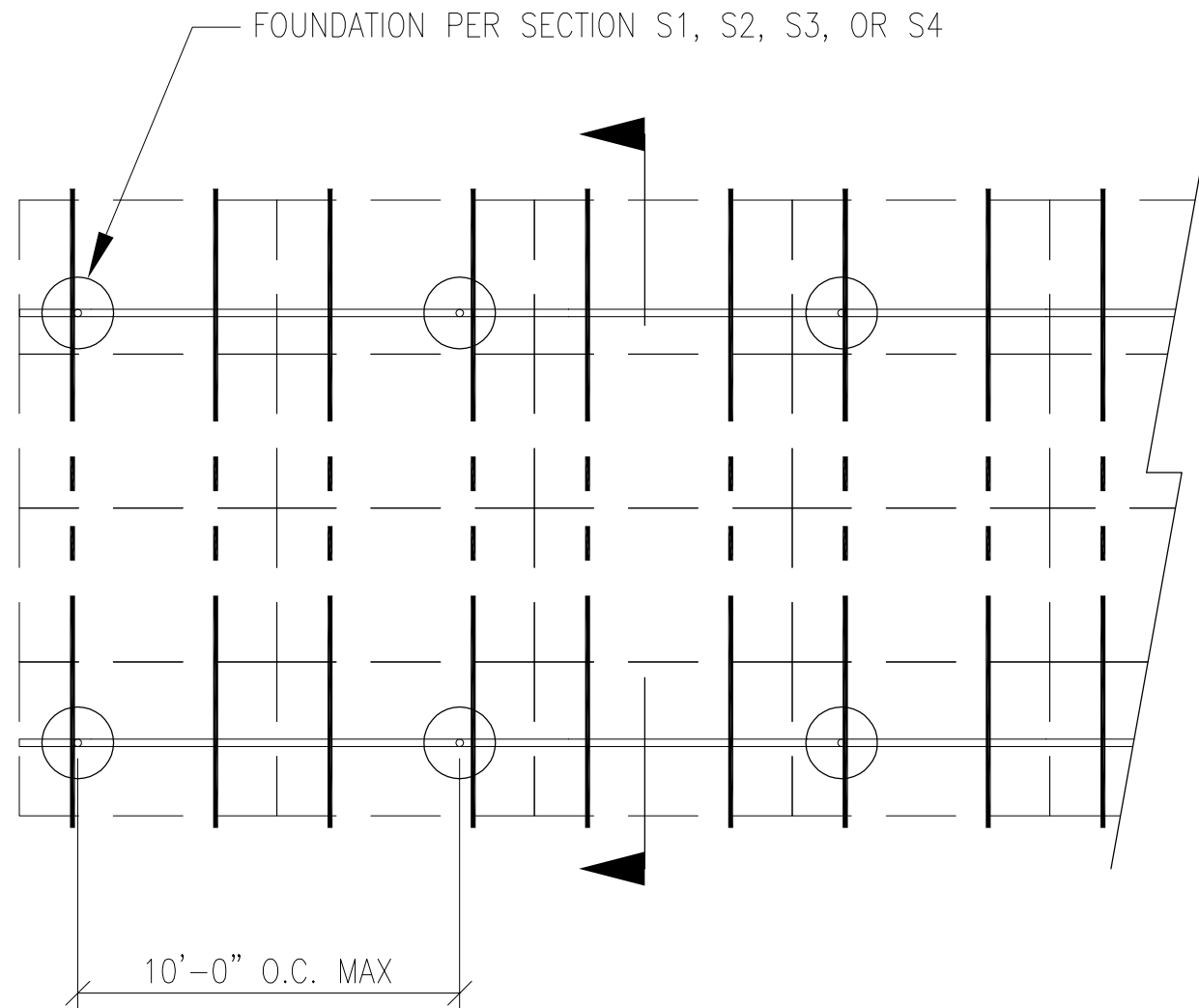

08/30/2021

PV ARRAY PLAN

N.T.S.

P1

Vector Engineers requires that we review each site specific install and is not liable for installs at site specific locations we have not reviewed.

PROJECT SUNMODO SUNTURF GROUND MOUNTS B1

SUBJECT DRILLED PIER OPTION

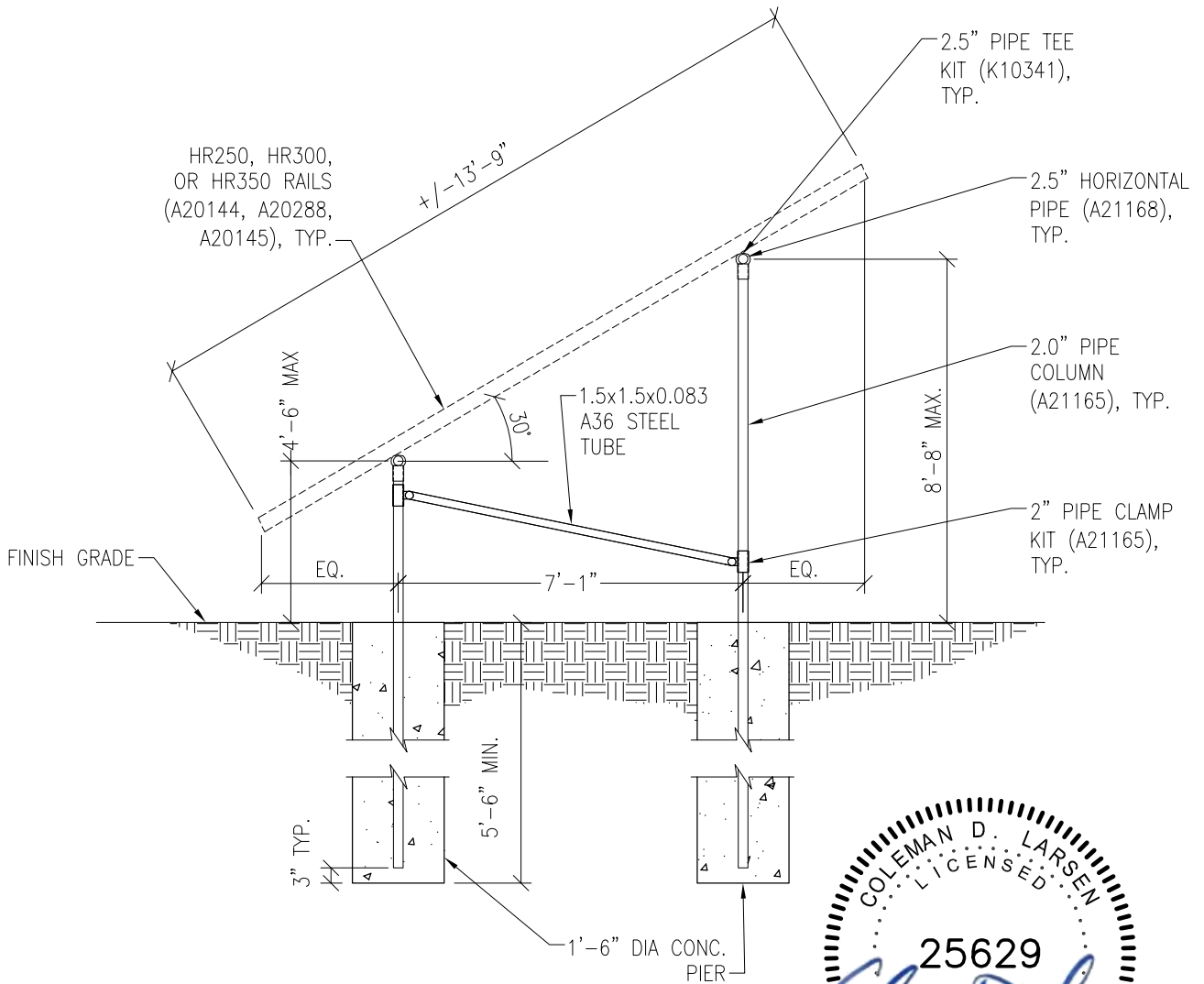

08/30/2021

Vector Engineers requires that we review each site specific install and is not liable for installs at site specific locations we have not reviewed.

PV ARRAY SECTION

N.T.S.

S1

PROJECT SUNMODO SUNTURF GROUND MOUNTS B1

SUBJECT HELICAL PIER OPTION

NOTES:

1. For ground mount components see Section S1.
2. A minimum of (1) helical pier must be load-tested as follows:
 - 2.1. Safety factor for uplift = 1.5,
 - 2.2. Safety factor for lateral loads = 2.0
 - 2.3. Upward deflection limit = 1/2"
 - 2.4. Lateral deflection limit = 1"
 - 2.5. The load tests must be performed by an approved contractor.

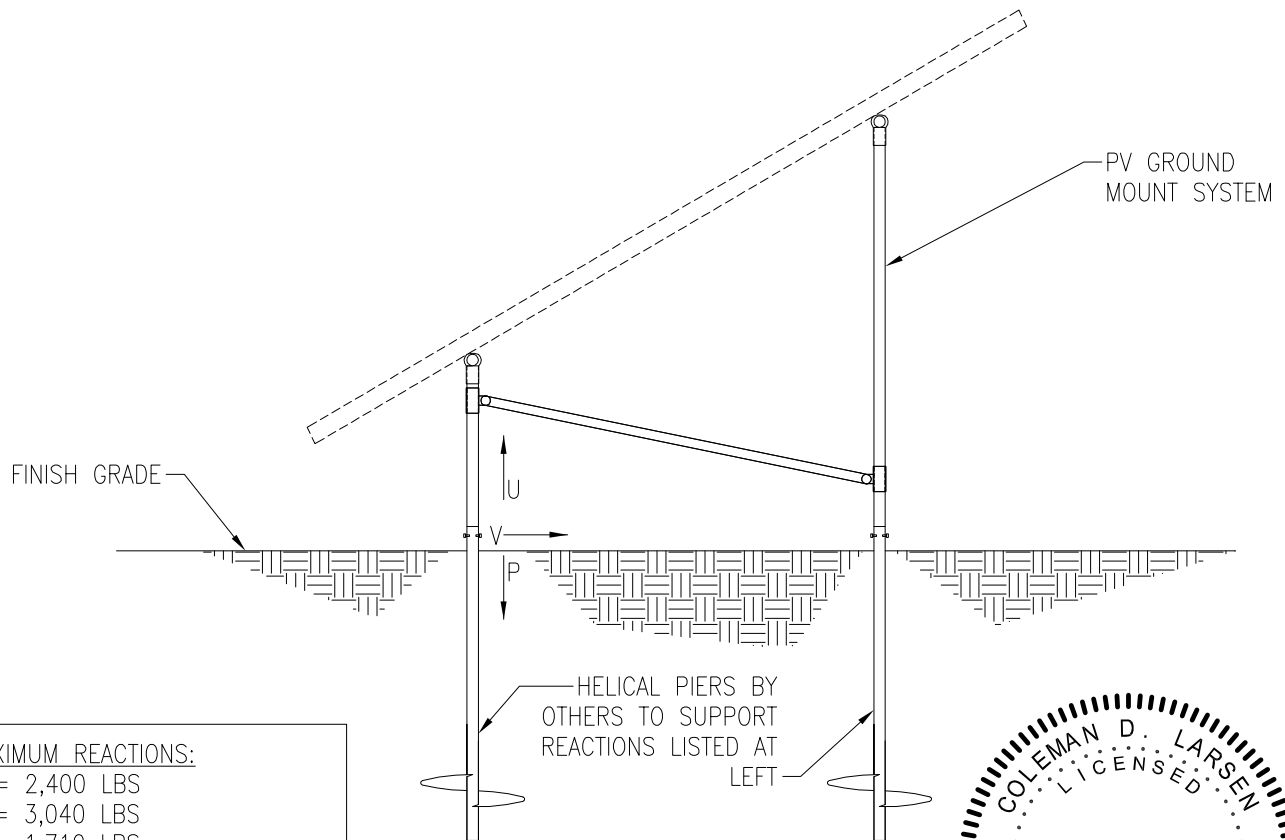

MAXIMUM REACTIONS:
 U = 2,400 LBS
 P = 3,040 LBS
 V = 1,710 LBS



08/30/2021

PV ARRAY SECTION

N.T.S.

S2

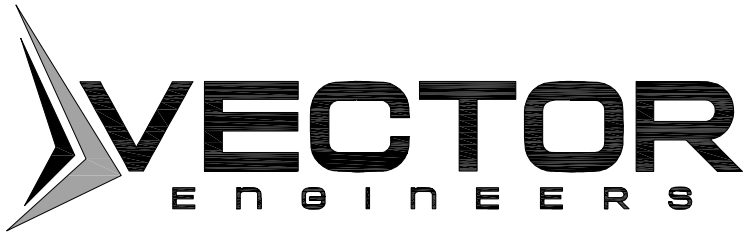

JOB NO. U2716-094-191

PROJECT SUNMODO SUNTURF GROUND MOUNTS B1

SUBJECT GROUND SCREW OPTION

NOTES:

- 1. For ground mount components see Section S1.
- 2. A minimum of (1) ground screw must be load-tested as follows:
 - 2.1. Safety factor for uplift = 1.5,
 - 2.2. Safety factor for lateral loads = 2.0
 - 2.3. Upward deflection limit = 1/2"
 - 2.4. Lateral deflection limit = 1"
 - 2.5. The load tests must be performed by an approved contractor.

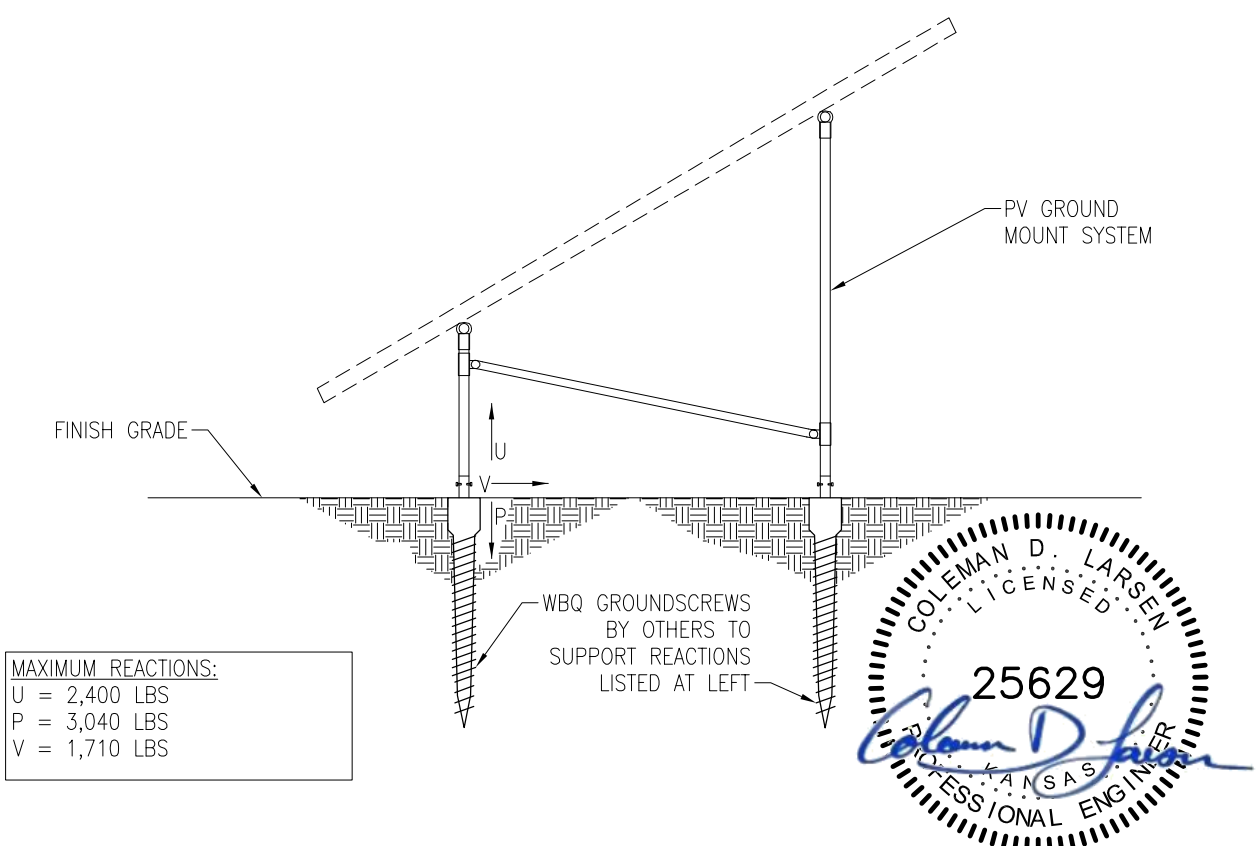

MAXIMUM REACTIONS:
 U = 2,400 LBS
 P = 3,040 LBS
 V = 1,710 LBS

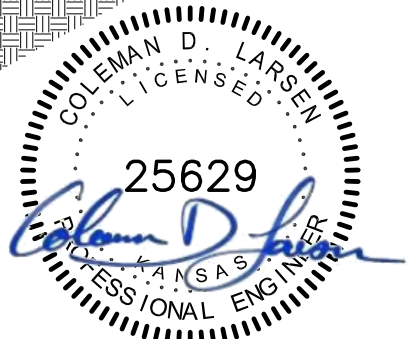

PV ARRAY SECTION

08/30/2021

N.T.S.

S3



JOB NO. U2716-094-191

PROJECT SUNMOD0 SUNTURF GROUND MOUNTS B1

SUBJECT BALLASTED BLOCK OPTION

NOTES:

1. For ground mount components see Section S1.



08/30/2021

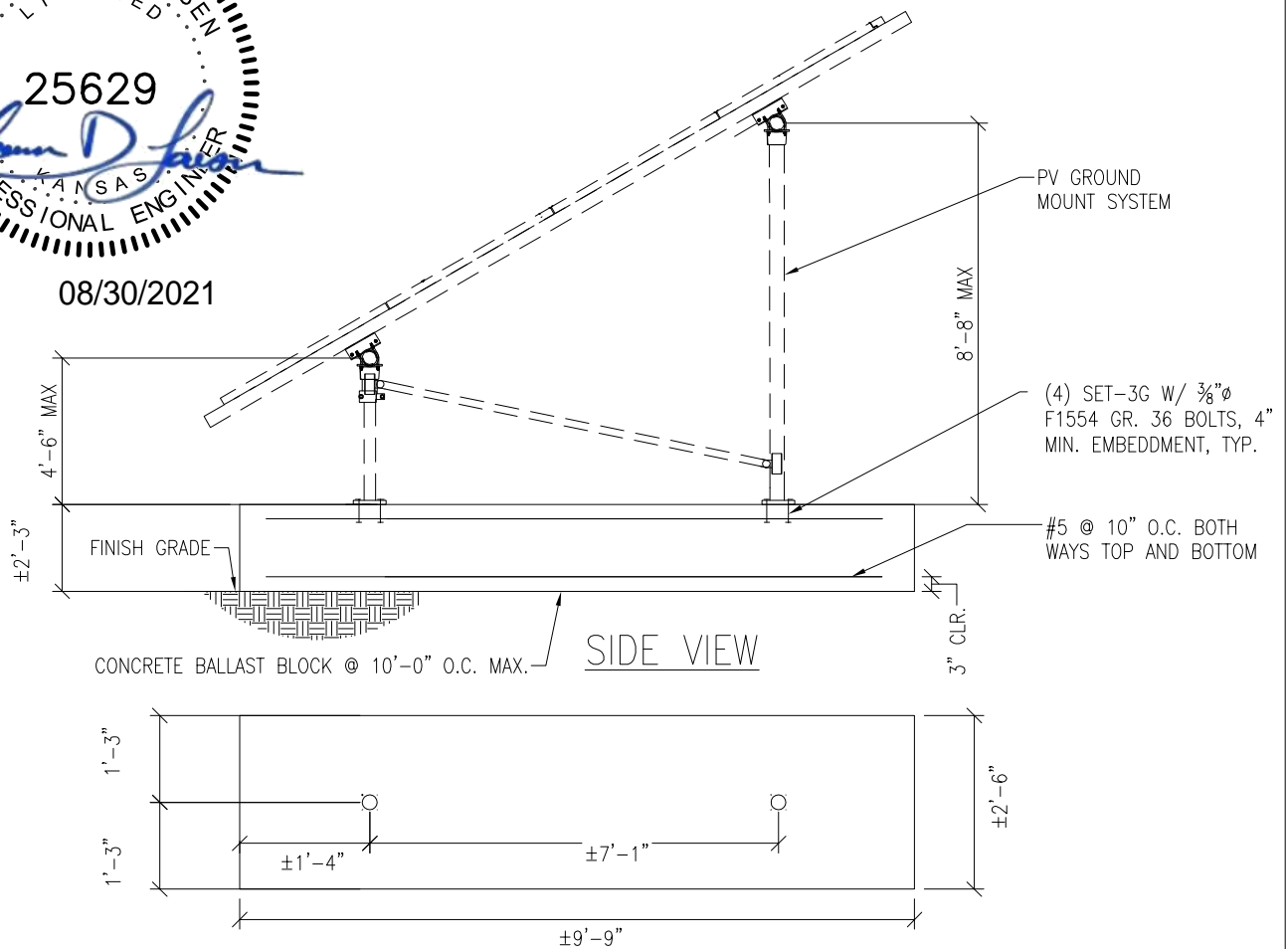

Vector Engineers requires that we review each site specific install and is not liable for installs at site specific locations we have not reviewed.

PV ARRAY SECTION

N.T.S.

S4

651 W GALENA PARK BLVD. #101
DRAPER, UTAH 84020

(801) 990-1775
(801) 990-1776 FAX

WWW.VECTORSE.COM

PROJECT: B1 – Sunmodo Sunturf GM

SUBJECT: Dead Load

Design Weight:

Individual Panel Weight [lb]:	50.7
Panel Transverse Length (T5) [in]:	41.2
Panel Transverse Length (T5) [ft]:	3.4
Panel Longitudinal Length (L2) [in]:	81.4
Panel Longitudinal Length (L2) [ft]:	6.8
Individual Panel Area [ft ²]:	23.3
Individual Panel Weight [psf]:	2.2
# of Panels in Transverse Direction:	4
Approximate Transverse Length (T4) [ft]:	13.7
# of Panels in Longitudinal Direction:	12
Approximate Longitudinal Length (L1) [ft]:	81.4
Transverse Column Spacing (T1) [ft]:	7.1
Longitudinal Column Spacing (L3) [ft]:	10.0
# of Columns in Longitudinal Direction:	9
# of Columns in Transverse Direction:	2
Total Number of Columns:	18
Panel Slope from Horizontal (a) [°]:	30.0
Short Column Height (H1) [ft]:	4.5
Approximate Tall Column Height (H2) [ft]:	8.6
Transverse Brace between Columns :	Yes
Approximate Brace Length (B1) [ft]:	9.0
Weight of Columns [plf]:	3.7
Weight of Cross Pipe [plf]:	3.7
Weight of Brace [plf]:	3.7
Tributary Transverse Length per Column [ft]:	6.9
Tributary Longitudinal Length per Column [ft]:	10.0
Tributary Area per Column [ft ²]:	68.7
Rail Weight [plf]:	1.0
Transverse Rail Weight per Column [lb]:	27.5
Longitudinal Rail Weight per Column [lb]:	36.5
Tall Column Weight [lb]:	31.4
Panel Weight per Column [lb]:	149.5
Rail Weight per Column [lb]:	27.5
Cross Pipe Weight per Column [lb]:	36.5
Brace Weight per Column [lb]:	16.4
Total Weight per Column (1.0 D) [lb]:	261.3

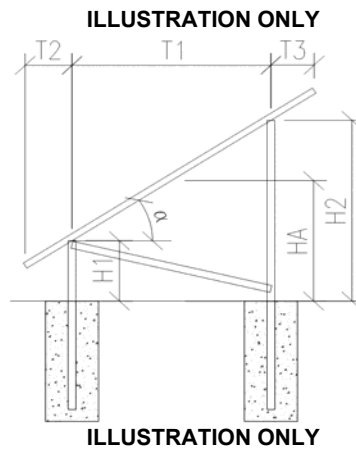
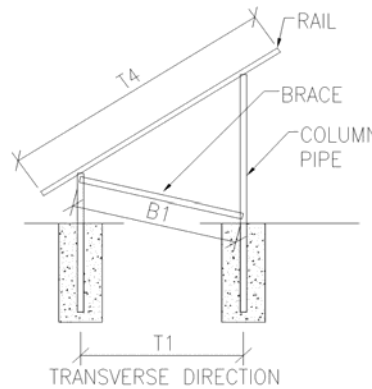
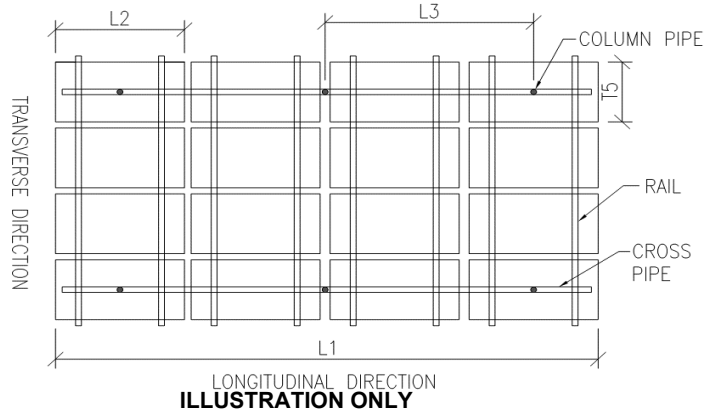

Assumptions:

- T2 = T3



JOB NO.: U2716-094-191

DESIGNED: STB

DATE: 07/25/19

PROJECT: B1 – Sunmodo Sunturf GM

SUBJECT: Snow Load

SNOW LOAD (S):

ASCE 7 Standard:	10	
Panel Slope from Horizontal [°]:	30.0	
Snow Ground Load, p_g [psf]:	30.0	(Section 7.2)
Terrain Category:	C	(Table 7-2)
Exposure of Roof:	Fully Exposed	(Table 7-2)
Exposure Factor, C_e :	0.9	(Table 7-2)
Thermal Factor, C_t :	1.2	(Table 7-3)
Risk Category:	I	(Table 1.5-1)
Importance Factor, I_s :	0.8	(Table 1.5-2)
Flat Roof Snow Load, p_f [psf]:	18	(Equation 7.3-1)
Minimum Roof Snow Load, p_m [psf]:	0	(Section 7.3.4)
Unobstructed Slippery Surface?	Yes	(Section 7.4)
Slope Factor Figure:	Figure 7-2c	(Section 7.4)
Roof Slope Factor, C_s :	0.727	(Figure 7-2)
Sloped Roof Snow Load, p_s [psf]:	13	(Equation 7.4-1)
Design Snow Load, S [psf]:	13	
Tributary Transverse Length [ft]:	5.9	
Tributary Longitudinal Length [ft]:	10	
Tributary Area per Column [ft ²]:	59.5	
Snow Load per Column (1.0 S) [lb]:	784.7	



JOB NO.: U2716-094-191 DESIGNED: STB
 DATE: 06/07/19

PROJECT: B1 – Sunmodo Sunturf GM

SUBJECT: Wind Pressure

Design Wind Load:

ASCE 7 Standard:	10	
Basic Wind Speed, V [mph]:	105	
Risk Category:	I	
Exposure Category	C	(Section 26.7.3)
Velocity Pressure Exposure Coefficient, K_h :	0.85	(Table 27.3-1)
Topographic Factor, K_{ht} :	1.0	(Section 26.8.2)
Wind Directionality Factor, K_d :	0.85	(Table 26.6-1)
Internal Pressure Coefficient, GC_{pi} :	0.00	(Table 26.11-1)
Velocity Pressure, q_h [psf]:	20.4	(Equation 27.3-1)
Gust Effect Factor, G:	0.85	(Section 26.9.1)
Panel Slope [degrees]:	30.0	

Net Pressure Coefficients (C_N) per: (Figure 27.4-4)

Clear Wind Flow	C_{NW}	C_{NL}
Case 1 ($\gamma = 0^\circ$, Load Case A)	-1.80	-1.80
Case 2 ($\gamma = 0^\circ$, Load Case B)	-2.50	-0.50
Case 3 ($\gamma = 180^\circ$, Load Case A)	2.10	2.10
Case 4 ($\gamma = 180^\circ$, Load Case B)	2.60	1.00

Design Wind Pressures (p) [psf] per: (Equation 27.4-3)

Clear Wind Flow	$q_h GC_{NW}$	$q_h GC_{NL}$
Case 1 ($\gamma = 0^\circ$, Load Case A)	-31.2	-31.2
Case 2 ($\gamma = 0^\circ$, Load Case B)	-43.3	-8.7
Case 3 ($\gamma = 180^\circ$, Load Case A)	36.4	36.4
Case 4 ($\gamma = 180^\circ$, Load Case B)	45.1	17.3

Wind Pressure on Each Side of Panels [psf]

Clear Wind Flow	Short Col. Pressure	Long Col. Pressure
Case 1 ($\gamma = 0^\circ$, Load Case A)	-31.2	-31.2
Case 2 ($\gamma = 0^\circ$, Load Case B)	-8.7	-43.3
Case 3 ($\gamma = 180^\circ$, Load Case A)	36.4	36.4
Case 4 ($\gamma = 180^\circ$, Load Case B)	45.1	17.3



JOB NO.: U2716-094-191

PROJECT: B1 – Sunmodo Sunturf GM

SUBJECT: Open Building Wind Loads

Design Wind Load Per ASCE 7-10

$$p = q_h G C_n$$

Velocity Pressure Exposure Coefficient, K_z :	0.85	(Table 27.3-1)
Topographic Factor, K_{zt} :	1.0	(Section 26.8.2)
Wind Directionality Factor, K_d :	0.85	(Table 26.6-1)
Ultimate Wind Speed, V [mph]:	105	

Velocity Pressure, q_h [psf]:	20.4	(Equation 27.3-1)
Gust Effect Factor, G :	0.85	(Section 26.9.1)

$\gamma = 90^\circ$ or 270°

Force Coefficient, C_N :

Horizontal Distance from Winward Edge	Roof angle			Obstructed Wind Flow
	30	A	CN	
$\leq h$	30	A	-0.8	
		B	0.8	
$> h, \leq 2h$	30	A	-0.6	
		B	0.5	
$> 2h$	30	A	-0.3	
		B	0.3	

Design Wind Pressure, p [psf]:

Horizontal Distance from Winward Edge	Roof angle			Obstructed Wind Flow
	30	A		
$\leq h$	30	A	-13.9	
		B	13.9	
$> h, \leq 2h$	30	A	-10.4	
		B	8.7	
$> 2h$	30	A	-5.2	
		B	5.2	



JOB NO.: U2716-094-191

DESIGNED: STB

Foundation Option 1: Drilled Concrete Pier



JOB NO.: U2716-094-191
DATE: 07/25/19

DESIGNED: STB

PROJECT: B1 – Sunmodo Sunturf GM

Drilled Pier Design

Design Loads:

Max. Shear, V [k]:	1.7	Max. Down, P _d [k]:	3.0
Max. Moment, M [k-ft]:	0.0	Max. Uplift, P _u [k]:	2.4

Pier Properties:

Pier Diameter, b [ft]:	1.5	Volume of Concrete [ft ³]:	10
Min. Pier Diameter, b _{min} (opt'l) [ft]:		Volume of Concrete [yd ³]:	0.4
Top of Pier Elevation [ft]:	0.00	Weight of Concrete [k]:	1.5
Pier Depth, d [ft]:	5.5		
Min. Pier Depth, d _{min} (opt'l) [ft]:			
Max. Pier Depth, d _{max} (opt'l) [ft]:			

Soil Properties:

Allow. Bearing Pressure [psf]:	1,500	<u>Optional Parameters for Uplift:</u>	
1/3 increase for short term loads?	No	Skin Friction [psf]:	250 (IBC 1810.3.3.1.4)
Lateral Bearing, S [pcf]:	150	Top Length to Ignore [ft]:	0.0
Max. Lateral Bearing (opt'l) [psf]:		1/3 increase for short term loads?	No
Top Depth to Ignore [ft]:	0.0	Combine w/ Bearing:	No
1/3 increase for short term loads?	No		
1/2" deflection at t/o pier allowed:	Yes		

Check Bearing:

Bearing Capacity [k]:	6.5	Bearing capacity OK.
-----------------------	-----	-----------------------------

Check Uplift:

Uplift Capacity [k]:	7.8	Uplift capacity OK.
----------------------	-----	----------------------------

Check Lateral Bearing:

Applied Lateral Force, P [lb]:	1,710	
Point of Application, h [ft]:	0.0	
S _{1_max} [psf]:		
S ₁ [psf]:	550	
A = 2.34*P/(S ₁ b):	4.85	
Required Pier Depth, d _{reqd} [ft]:	4.9	Lateral bearing capacity OK.

Foundation Option 2: Helical Pier

The ground screws and helical piers must be tested to 1.5 times uplift and 2.0 times lateral reactions found in the table below.

Load (ASD)	Value (lbs)	Factor of Safety	Test Value (lbs)
UPLIFT	2400	1.5	3600
LATERAL	1710	2	3420

Foundation Option 3: Ground Screw

The ground screws and helical piers must be tested to 1.5 times uplift and 2.0 times lateral reactions found in the table below.

Load (ASD)	Value (lbs)	Factor of Safety	Test Value (lbs)
UPLIFT	2400	1.5	3600
LATERAL	1710	2	3420



JOB NO.: U2716-094-191

DESIGNED: STB

Foundation Option 4: Ballasted Block

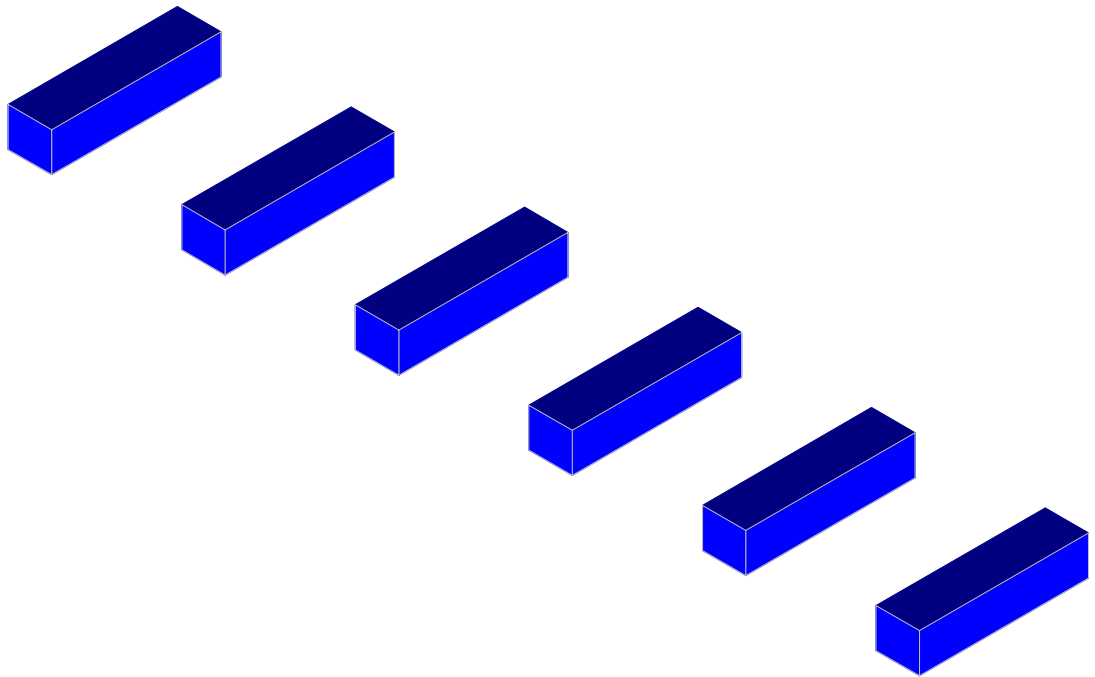

Results for LC 1, 1.0 D

Vector Structural Engineeri..	Ground Mount	SK - 14
STB		June 7, 2019 at 4:41 PM
U2716.094.191		USA B1 GM v3.r3d

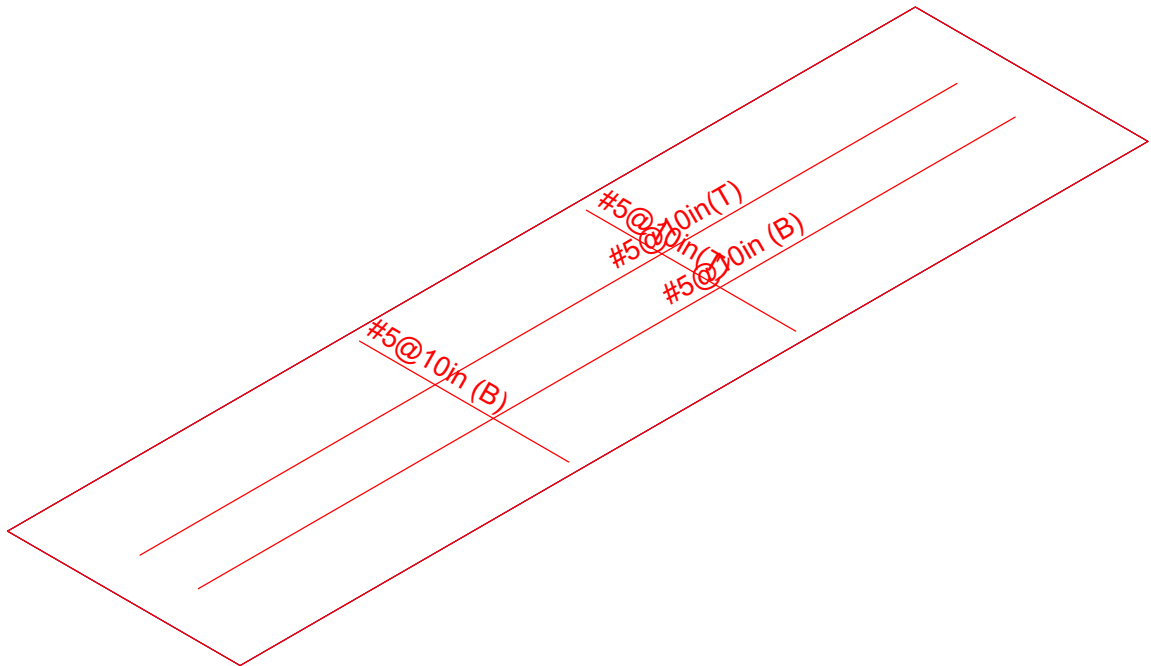

Results for LC 1, 1.0 D

Vector Structural Engineeri..	Ground Mount	SK - 15
STB		June 7, 2019 at 4:41 PM
U2716.094.191		USA B1 GM v3.r3d



Point Loads and Moments (Cat 19 : OL4) (Continued)

	Label	Direction	Magnitude[lb,lb-ft]
13	R3D_N109	X	-5.646
14	R3D_N109	Y	2858.121
15	R3D_N109	Z	-2428.676
16	R3D_N110A	X	29.115
17	R3D_N110A	Y	924.253
18	R3D_N110A	Z	76.99
19	R3D_N121	X	3.695
20	R3D_N121	Y	2733.397
21	R3D_N121	Z	-2175.758
22	R3D_N122	X	-1.498
23	R3D_N122	Y	960.379
24	R3D_N122	Z	77.011
25	R3D_N133B	X	-3.715
26	R3D_N133B	Y	2734.055
27	R3D_N133B	Z	-2176.325
28	R3D_N134B	Y	959.368
29	R3D_N134B	Z	77.033
30	R3D_N137C	X	131.627
31	R3D_N137C	Y	1913.874
32	R3D_N137C	Z	-1446.231
33	R3D_N138B	X	183.113
34	R3D_N138B	Y	722.55
35	R3D_N138B	Z	58.521

Point Loads and Moments (Cat 20 : OL5)

	Label	Direction	Magnitude[lb,lb-ft]
1	R3D_N1_1	X	-73.937
2	R3D_N1_1	Y	1155.083
3	R3D_N1_1	Z	-649.695
4	R3D_N2_1	X	-45.664
5	R3D_N2_1	Y	25.47
6	R3D_N2_1	Z	23.184
7	R3D_N132	X	6.502
8	R3D_N132	Y	610.134
9	R3D_N132	Z	-405.766
10	R3D_N133	Y	-10.941
11	R3D_N133	Z	12.956
12	R3D_N109	X	5.707
13	R3D_N109	Y	1205.466
14	R3D_N109	Z	-779.431
15	R3D_N110A	X	20.687
16	R3D_N110A	Y	-23.332
17	R3D_N110A	Z	23.517
18	R3D_N121	X	4.552
19	R3D_N121	Y	591.517
20	R3D_N121	Z	-347.967
21	R3D_N122	Y	14.352
22	R3D_N122	Z	15.222
23	R3D_N133B	X	2.567
24	R3D_N133B	Y	620.028
25	R3D_N133B	Z	-367.49
26	R3D_N134B	X	2.885
27	R3D_N134B	Y	5.001
28	R3D_N134B	Z	13.35
29	R3D_N137C	X	54.657
30	R3D_N137C	Y	459.744

Load Combinations (Continued)

Label	Solve	Service	A..SF	Cat..Fa...	Cat..Fa...	Cat..Fa...	Cat..Fa...	Cat..Fa...	Cat..Fa...	Cat..Fa...	Cat..Fa...	Cat..Fa...	Cat..Fa...	Cat..Fa...	Cat..Fa...	Cat..Fa...	Cat..Fa...	Cat..Fa...
3	1.0 D + 0....	Yes	Yes	1.5	DL	1	RLL		OL1	.6								
4	1.0 D + 0....	Yes	Yes	1.5	DL	1	RLL		OL2	.6								
5	1.0 D + 0....	Yes	Yes	1.5	DL	1	RLL		OL3	.6								
6	1.0 D + 0....	Yes	Yes	1.5	DL	1	RLL		OL4	.6								
7	1.0 D + 0....	Yes	Yes	1.5	DL	1	RLL		OL5	.6								
8	1.0 D + 0....	Yes	Yes	1.5	DL	1	RLL		OL6	.6								
9	1.0 D + 0....	Yes	Yes	1.5	DL	1	RLL	.75	OL1	.45								
10	1.0 D + 0....	Yes	Yes	1.5	DL	1	RLL	.75	OL2	.45								
11	1.0 D + 0....	Yes	Yes	1.5	DL	1	RLL	.75	OL3	.45								
12	1.0 D + 0....	Yes	Yes	1.5	DL	1	RLL	.75	OL4	.45								
13	1.0 D + 0....	Yes	Yes	1.5	DL	1	RLL	.75	OL5	.45								
14	1.0 D + 0....	Yes	Yes	1.5	DL	1	RLL	.75	OL6	.45								
15	0.6 D + 0....	Yes	Yes		DL	.6	RLL		OL1	.6								
16	0.6 D + 0....	Yes	Yes		DL	.6	RLL		OL2	.6								
17	0.6 D + 0....	Yes	Yes		DL	.6	RLL		OL3	.6								
18	0.6 D + 0....	Yes	Yes		DL	.6	RLL		OL4	.6								
19	0.6 D + 0....	Yes	Yes		DL	.6	RLL		OL5	.6								
20	0.6 D + 0....	Yes	Yes		DL	.6	RLL		OL6	.6								
21																		
22	1.4D	Yes			DL	1.4												
23	1.2D+1.6SL	Yes			DL	1.2	RLL	1.6										
24	1.2D+1.6S...	Yes			DL	1.2	RLL	1.6	OL1	.5								
25	1.2D+1.6S...	Yes			DL	1.2	RLL	1.6	OL2	.5								
26	1.2D+1.6S...	Yes			DL	1.2	RLL	1.6	OL3	.5								
27	1.2D+1.6S...	Yes			DL	1.2	RLL	1.6	OL4	.5								
28	1.2D+1.6S...	Yes			DL	1.2	RLL	1.6	OL5	.5								
29	1.2D+1.6S...	Yes			DL	1.2	RLL	1.6	OL6	.5								
30	1.2D+1.0...	Yes			DL	1.2			OL1	1								
31	1.2D-1.0Wx	Yes			DL	1.2			OL2	1								
32	1.2D+1.0...	Yes			DL	1.2			OL3	1								
33	1.2D-1.0Wz	Yes			DL	1.2			OL4	1								
34	1.2D+1.0...	Yes			DL	1.2			OL5	1								
35	1.2D-1.0...	Yes			DL	1.2			OL6	1								
36	.9D+1.0Wx	Yes			DL	.9			OL1	1								
37	.9D-1.0Wx	Yes			DL	.9			OL2	1								
38	.9D+1.0Wz	Yes			DL	.9			OL3	1								
39	.9D-1.0Wz	Yes			DL	.9			OL4	1								
40	.9D+1.0W...	Yes			DL	.9			OL5	1								
41	.9D-1.0W90	Yes			DL	.9			OL6	1								

Design Strips

Label	Rebar Angle from Pl...	No. of Design Cuts	Design Rule
1 DS1	0	50	Typical
2 DS2	90	50	Typical

Load Categories

Category	Point Loads	Line Loads	Area Loads
1 DL	19		
2 RLL	23		
3 OL1	36		
4 OL2	36		
5 OL3	36		
6 OL4	35		
7 OL5	34		
8 OL6	34		



Company:		Date:	5/14/2018
Engineer:		Page:	1/6
Project:			
Address:			
Phone:			
E-mail:			

1. Project information

Customer company:
Customer contact name:
Customer e-mail:
Comment:

Project description:
Location:
Fastening description:

2. Input Data & Anchor Parameters

General

Design method: ACI 318-14
Units: Imperial units

Anchor Information:

Anchor type: Bonded anchor
Material: F1554 Grade 36
Diameter (inch): 0.375
Effective Embedment depth, h_{ef} (inch): 4.000
Code report: ICC-ES ESR-4057
Anchor category: -
Anchor ductility: Yes
 h_{min} (inch): 5.25
 c_{ac} (inch): 7.12
 c_{min} (inch): 1.75
 s_{min} (inch): 3.00

Base Material

Concrete: Normal-weight
Concrete thickness, h (inch): 24.00
State: Cracked
Compressive strength, f'_c (psi): 2500
 $\Psi_{c,v}$: 1.0
Reinforcement condition: B tension, B shear
Supplemental reinforcement: Not applicable
Reinforcement provided at corners: No
Ignore concrete breakout in tension: No
Ignore concrete breakout in shear: No
Hole condition: Dry concrete
Inspection: Periodic
Temperature range, Short/Long: 150/110°F
Ignore 6do requirement: Not applicable
Build-up grout pad: No

Base Plate

Length x Width x Thickness (inch): 4.75 x 4.75 x 0.31

Recommended Anchor

Anchor Name: SET-3G - SET-3G w/ 3/8"Ø F1554 Gr. 36
Code Report: ICC-ES ESR-4057





Company:		Date:	5/14/2018
Engineer:		Page:	2/6
Project:			
Address:			
Phone:			
E-mail:			

Load and Geometry

Load factor source: ACI 318 Section 5.3

Load combination: not set

Seismic design: No

Anchors subjected to sustained tension: No

Apply entire shear load at front row: No

Anchors only resisting wind and/or seismic loads: No

Strength level loads:

N_{ua} [lb]: 4000

V_{uax} [lb]: 525

V_{uay} [lb]: -2850

M_{ux} [ft-lb]: 0

M_{uy} [ft-lb]: 0

M_{uz} [ft-lb]: 0

<Figure 1>

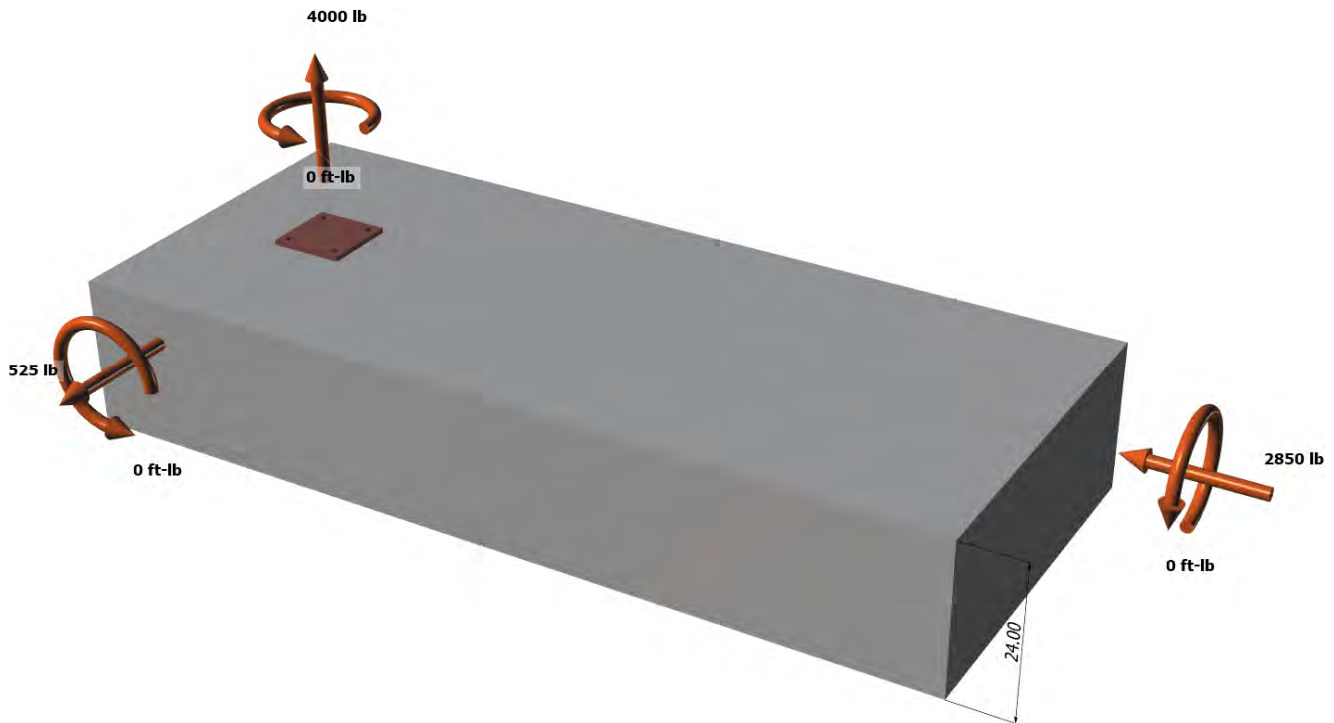



Company:		Date:	5/14/2018
Engineer:		Page:	3/6
Project:			
Address:			
Phone:			
E-mail:			

<Figure 2>

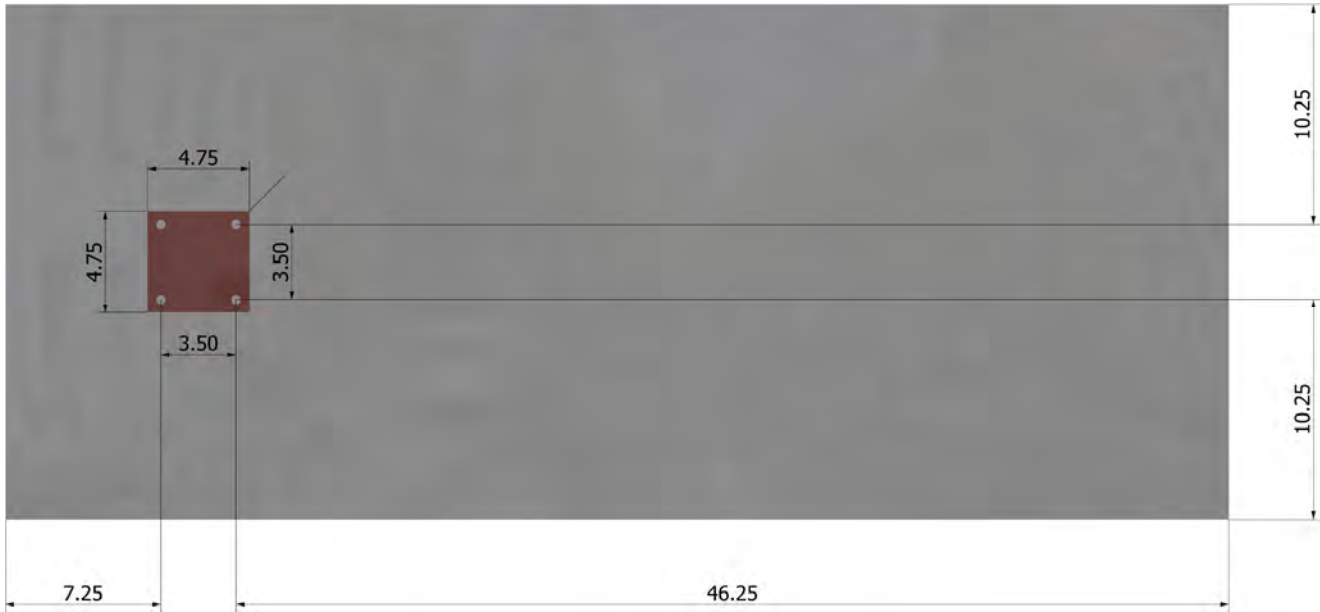



Company:		Date:	5/14/2018
Engineer:		Page:	4/6
Project:			
Address:			
Phone:			
E-mail:			

3. Resulting Anchor Forces

Anchor	Tension load, N _{ua} (lb)	Shear load x, V _{uax} (lb)	Shear load y, V _{uay} (lb)	Shear load combined, $\sqrt{(V_{uax})^2 + (V_{uay})^2}$ (lb)
1	1000.0	131.3	-712.5	724.5
2	1000.0	131.3	-712.5	724.5
3	1000.0	131.3	-712.5	724.5
4	1000.0	131.3	-712.5	724.5
Sum	4000.0	525.0	-2850.0	2898.0

Maximum concrete compression strain (%): 0.00
 Maximum concrete compression stress (psi): 0
 Resultant tension force (lb): 4000
 Resultant compression force (lb): 0
 Eccentricity of resultant tension forces in x-axis, e'_{Nx} (inch): 0.00
 Eccentricity of resultant tension forces in y-axis, e'_{Ny} (inch): 0.00
 Eccentricity of resultant shear forces in x-axis, e'_{Vx} (inch): 0.00
 Eccentricity of resultant shear forces in y-axis, e'_{Vy} (inch): 0.00

<Figure 3>

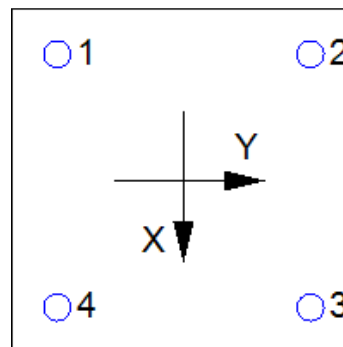

4. Steel Strength of Anchor in Tension (Sec. 17.4.1)

N _{sa} (lb)	φ	φN _{sa} (lb)
4525	0.75	3394

5. Concrete Breakout Strength of Anchor in Tension (Sec. 17.4.2)

$$N_b = K_c \lambda_a \sqrt{f_c} h_{ef}^{1.5} \text{ (Eq. 17.4.2.2a)}$$

K _c	λ _a	f _c (psi)	h _{ef} (in)	N _b (lb)
17.0	1.00	2500	4.000	6800

$$\phi N_{cbg} = \phi (A_{Nc} / A_{Nco}) \psi_{ec,N} \psi_{ed,N} \psi_{c,N} \psi_{cp,N} N_b \text{ (Sec. 17.3.1 \& Eq. 17.4.2.1b)}$$

A _{Nc} (in ²)	A _{Nco} (in ²)	c _{a,min} (in)	ψ _{ec,N}	ψ _{ed,N}	ψ _{c,N}	ψ _{cp,N}	N _b (lb)	φ	φN _{cbg} (lb)
240.25	144.00	7.25	1.000	1.000	1.00	1.000	6800	0.65	7374

6. Adhesive Strength of Anchor in Tension (Sec. 17.4.5)

$$\tau_{k,cr} = \tau_{k,cr,short-term} K_{sat} (f_c / 2,500)^n$$

τ _{k,cr} (psi)	f _{short-term}	K _{sat}	f _c (psi)	n	τ _{k,cr} (psi)
1346	1.00	1.00	2500	0.24	1346

$$N_{ba} = \lambda_a \tau_{cr} \pi d_a h_{ef} \text{ (Eq. 17.4.5.2)}$$

λ _a	τ _{cr} (psi)	d _a (in)	h _{ef} (in)	N _{ba} (lb)
1.00	1346	0.38	4.000	6343

$$\phi N_{ag} = \phi (A_{Na} / A_{Na0}) \psi_{ec,Na} \psi_{ed,Na} \psi_{cp,Na} N_{ba} \text{ (Sec. 17.3.1 \& Eq. 17.4.5.1b)}$$

A _{Na} (in ²)	A _{Na0} (in ²)	c _{Na} (in)	c _{a,min} (in)	ψ _{ec,Na}	ψ _{ed,Na}	ψ _{cp,Na}	N _{ba} (lb)	φ	φN _{ag} (lb)
198.45	112.09	5.29	7.25	1.000	1.000	1.000	6343	0.55	6176



Company:		Date:	5/14/2018
Engineer:		Page:	5/6
Project:			
Address:			
Phone:			
E-mail:			

8. Steel Strength of Anchor in Shear (Sec. 17.5.1)

V_{sa} (lb)	ϕ_{grout}	ϕ	$\phi_{grout}\phi V_{sa}$ (lb)
2715	1.0	0.65	1765

9. Concrete Breakout Strength of Anchor in Shear (Sec. 17.5.2)

Shear perpendicular to edge in x-direction:

$V_{bx} = \min|7(l_e / d_a)^{0.2} \sqrt{d_a} \lambda_a \sqrt{f_c} c_{a1}^{1.5}; 9 \lambda_a \sqrt{f_c} c_{a1}^{1.5}|$ (Eq. 17.5.2.2a & Eq. 17.5.2.2b)

l_e (in)	d_a (in)	λ_a	f_c (psi)	c_{a1} (in)	V_{bx} (lb)
3.00	0.375	1.00	2500	13.75	16564

$\phi V_{cbgx} = \phi (A_{Vc} / A_{Vco}) \psi_{ec,v} \psi_{ed,v} \psi_{c,v} \psi_{h,v} V_{bx}$ (Sec. 17.3.1 & Eq. 17.5.2.1b)

A_{Vc} (in ²)	A_{Vco} (in ²)	$\psi_{ec,v}$	$\psi_{ed,v}$	$\psi_{c,v}$	$\psi_{h,v}$	V_{bx} (lb)	ϕ	ϕV_{cbgx} (lb)
647.11	850.78	1.000	0.805	1.000	1.000	16564	0.70	7103

Shear perpendicular to edge in y-direction:

$V_{by} = \min|7(l_e / d_a)^{0.2} \sqrt{d_a} \lambda_a \sqrt{f_c} c_{a1}^{1.5}; 9 \lambda_a \sqrt{f_c} c_{a1}^{1.5}|$ (Eq. 17.5.2.2a & Eq. 17.5.2.2b)

l_e (in)	d_a (in)	λ_a	f_c (psi)	c_{a1} (in)	V_{by} (lb)
3.00	0.375	1.00	2500	10.75	11450

$\phi V_{cbgy} = \phi (A_{Vc} / A_{Vco}) \psi_{ec,v} \psi_{ed,v} \psi_{c,v} \psi_{h,v} V_{by}$ (Sec. 17.3.1 & Eq. 17.5.2.1b)

A_{Vc} (in ²)	A_{Vco} (in ²)	$\psi_{ec,v}$	$\psi_{ed,v}$	$\psi_{c,v}$	$\psi_{h,v}$	V_{by} (lb)	ϕ	ϕV_{cbgy} (lb)
387.00	520.03	1.000	0.891	1.000	1.000	11450	0.70	5313

Shear parallel to edge in x-direction:

$V_{by} = \min|7(l_e / d_a)^{0.2} \sqrt{d_a} \lambda_a \sqrt{f_c} c_{a1}^{1.5}; 9 \lambda_a \sqrt{f_c} c_{a1}^{1.5}|$ (Eq. 17.5.2.2a & Eq. 17.5.2.2b)

l_e (in)	d_a (in)	λ_a	f_c (psi)	c_{a1} (in)	V_{by} (lb)
3.00	0.375	1.00	2500	7.25	6342

$\phi V_{cbgx} = \phi (2)(A_{Vc} / A_{Vco}) \psi_{ec,v} \psi_{ed,v} \psi_{c,v} \psi_{h,v} V_{by}$ (Sec. 17.3.1, 17.5.2.1(c) & Eq. 17.5.2.1b)

A_{Vc} (in ²)	A_{Vco} (in ²)	$\psi_{ec,v}$	$\psi_{ed,v}$	$\psi_{c,v}$	$\psi_{h,v}$	V_{by} (lb)	ϕ	ϕV_{cbgx} (lb)
261.00	236.53	1.000	1.000	1.000	1.000	6342	0.70	9797

Shear parallel to edge in y-direction:

$V_{bx} = \min|7(l_e / d_a)^{0.2} \sqrt{d_a} \lambda_a \sqrt{f_c} c_{a1}^{1.5}; 9 \lambda_a \sqrt{f_c} c_{a1}^{1.5}|$ (Eq. 17.5.2.2a & Eq. 17.5.2.2b)

l_e (in)	d_a (in)	λ_a	f_c (psi)	c_{a1} (in)	V_{bx} (lb)
3.00	0.375	1.00	2500	10.25	10661

$\phi V_{cbgy} = \phi (2)(A_{Vc} / A_{Vco}) \psi_{ec,v} \psi_{ed,v} \psi_{c,v} \psi_{h,v} V_{bx}$ (Sec. 17.3.1, 17.5.2.1(c) & Eq. 17.5.2.1b)

A_{Vc} (in ²)	A_{Vco} (in ²)	$\psi_{ec,v}$	$\psi_{ed,v}$	$\psi_{c,v}$	$\psi_{h,v}$	V_{bx} (lb)	ϕ	ϕV_{cbgy} (lb)
401.67	472.78	1.000	1.000	1.000	1.000	10661	0.70	12680

10. Concrete Pryout Strength of Anchor in Shear (Sec. 17.5.3)

$\phi V_{cp} = \phi \min|k_{cp} N_{ba}; k_{cp} N_{cbg}| = \phi \min|k_{cp} (A_{Na} / A_{Na0}) \psi_{ec,Na} \psi_{ed,Na} \psi_{cp,Na} N_{ba}; k_{cp} (A_{Nc} / A_{Nco}) \psi_{ec,N} \psi_{ed,N} \psi_{c,N} \psi_{cp,N} N_b|$ (Sec. 17.3.1 & Eq. 17.5.3.1b)

k_{cp}	A_{Na} (in ²)	A_{Na0} (in ²)	$\psi_{ed,Na}$	$\psi_{ec,Na}$	$\psi_{cp,Na}$	N_{ba} (lb)	N_a (lb)
2.0	198.45	112.09	1.000	1.000	1.000	6343	11230

A_{Nc} (in ²)	A_{Nco} (in ²)	$\psi_{ec,N}$	$\psi_{ed,N}$	$\psi_{c,N}$	$\psi_{cp,N}$	N_b (lb)	N_{cb} (lb)	ϕ
240.25	144.00	1.000	1.000	1.000	1.000	6800	11345	0.70

Input data and results must be checked for agreement with the existing circumstances, the standards and guidelines must be checked for plausibility.



Company:		Date:	5/14/2018
Engineer:		Page:	6/6
Project:			
Address:			
Phone:			
E-mail:			

ϕV_{cpq} (lb)
15722

11. Results

Interaction of Tensile and Shear Forces (Sec. R17.6)

Tension	Factored Load, N_{ua} (lb)	Design Strength, ϕN_n (lb)	Ratio	Status	
Steel	1000	3394	0.29	Pass	
Concrete breakout	4000	7374	0.54	Pass	
Adhesive	4000	6176	0.65	Pass (Governs)	
Shear	Factored Load, V_{ua} (lb)	Design Strength, ϕV_n (lb)	Ratio	Status	
Steel	724	1765	0.41	Pass	
T Concrete breakout x+	525	7103	0.07	Pass	
T Concrete breakout y-	2850	5313	0.54	Pass	
Concrete breakout y-	263	9797	0.03	Pass	
Concrete breakout x-	1425	12680	0.11	Pass	
Concrete breakout, combined	-	-	0.54	Pass (Governs)	
Pryout	2898	15722	0.18	Pass	
Interaction check	$(N_{ua}/\phi N_{ua})^{5/3}$	$(V_{ua}/\phi V_{ua})^{5/3}$	Combined Ratio	Permissible	Status
Sec. R17.6	0.48	0.36	84.5%	1.0	Pass

SET-3G w/ 3/8"Ø F1554 Gr. 36 with hef = 4.000 inch meets the selected design criteria.

12. Warnings

- Designer must exercise own judgement to determine if this design is suitable.
- Refer to manufacturer's product literature for hole cleaning and installation instructions.



JOB NO.: U2716-094-191

DESIGNED: STB

Framing Analysis

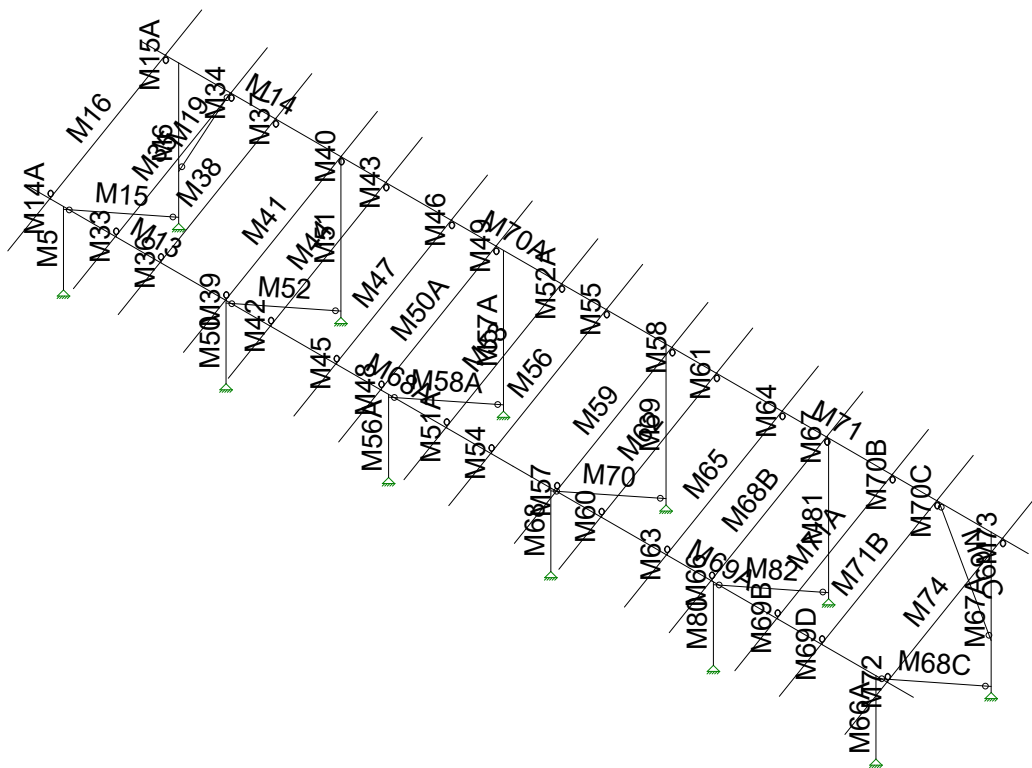

Vector Structural Engineeri...	Ground Mount	SK - 3
STB		June 7, 2019 at 3:55 PM
U2716.094.191		USA B1 GM v3.r3d

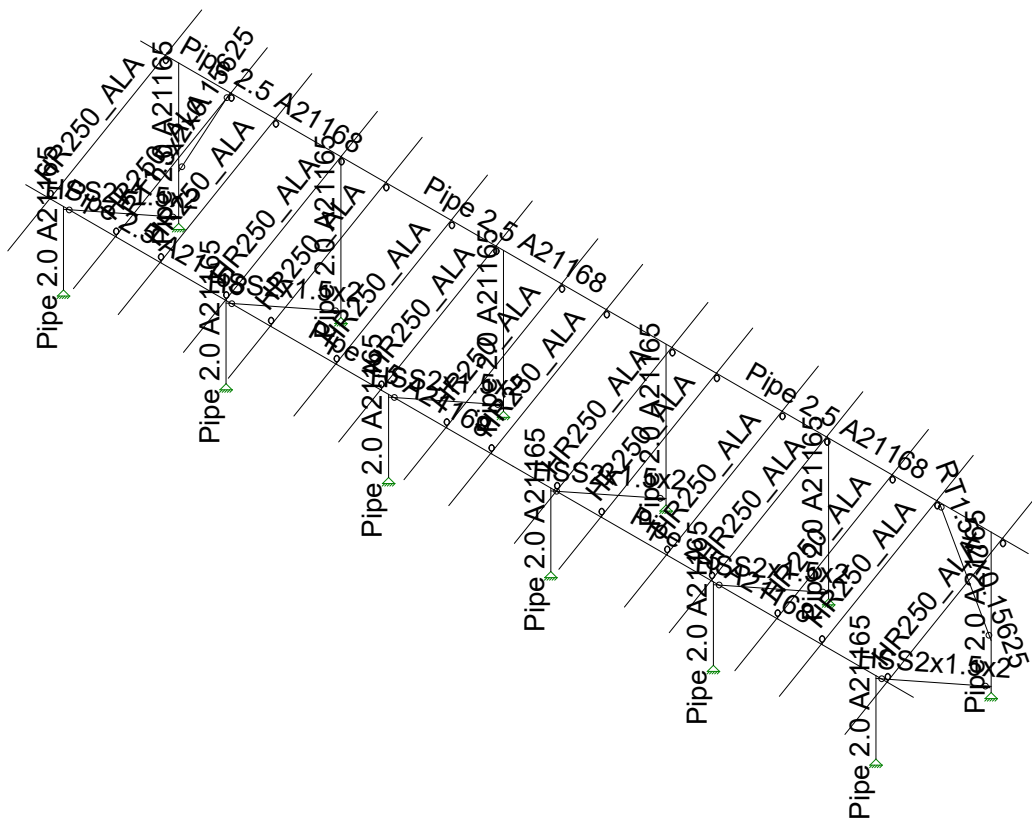

Vector Structural Engineeri...
STB
U2716.094.191

Ground Mount

SK - 4
June 7, 2019 at 3:55 PM
USA B1 GM v3.r3d

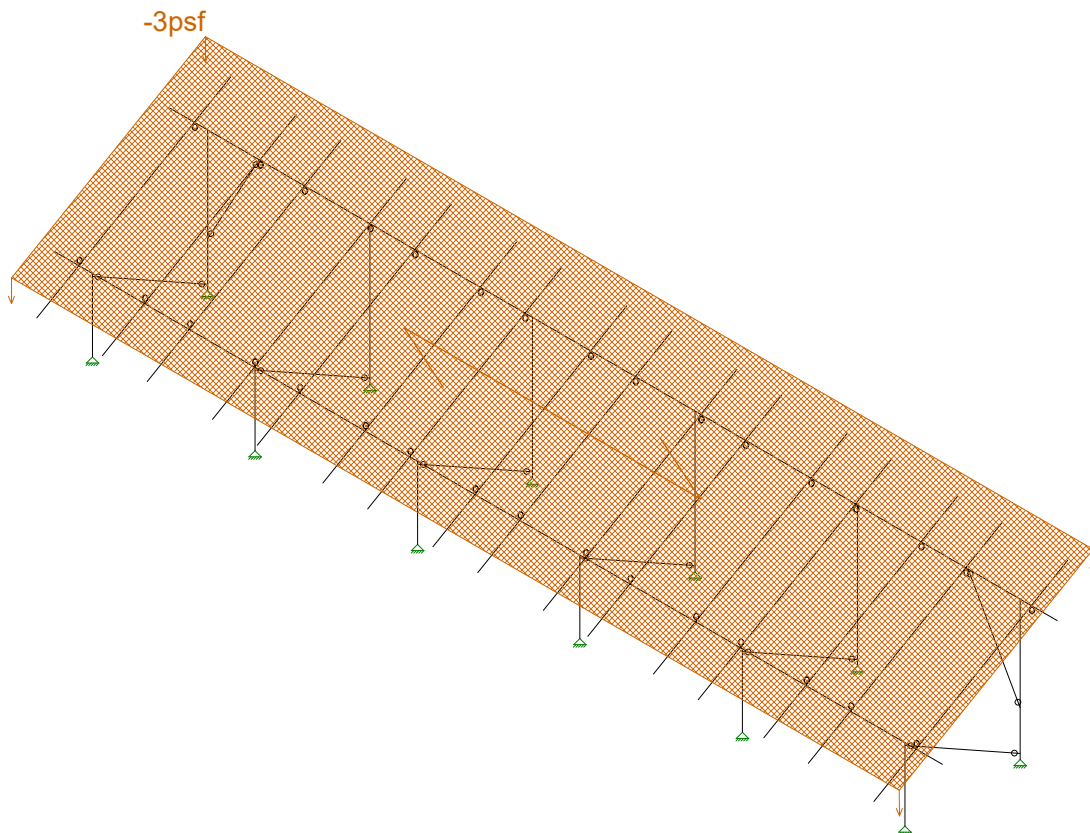

Loads: BLC 2, Solar Panel Weight

Vector Structural Engineeri..	Ground Mount	SK - 5
STB		June 7, 2019 at 3:55 PM
U2716.094.191		USA B1 GM v3.r3d

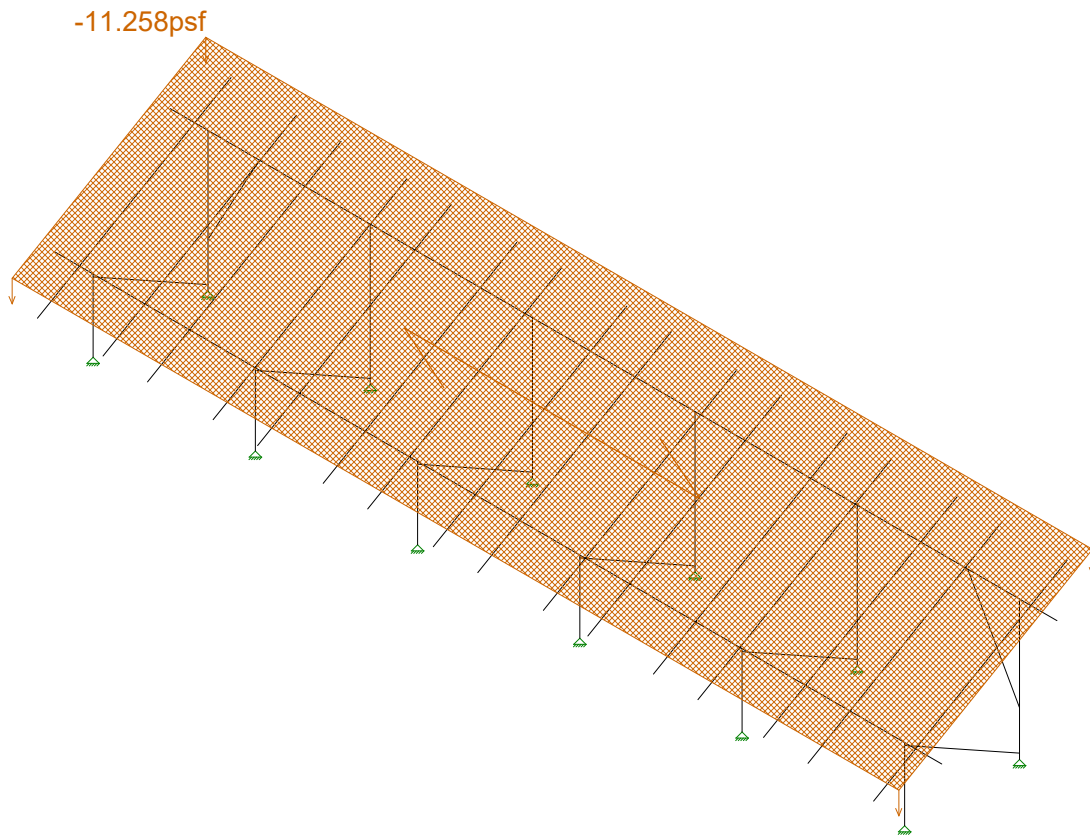

Loads: BLC 3, Roof Live/Snow

Vector Structural Engineeri..	Ground Mount	SK - 1
STB		July 25, 2019 at 4:26 PM
U2716.094.191		USA B1 GM v4.r3d

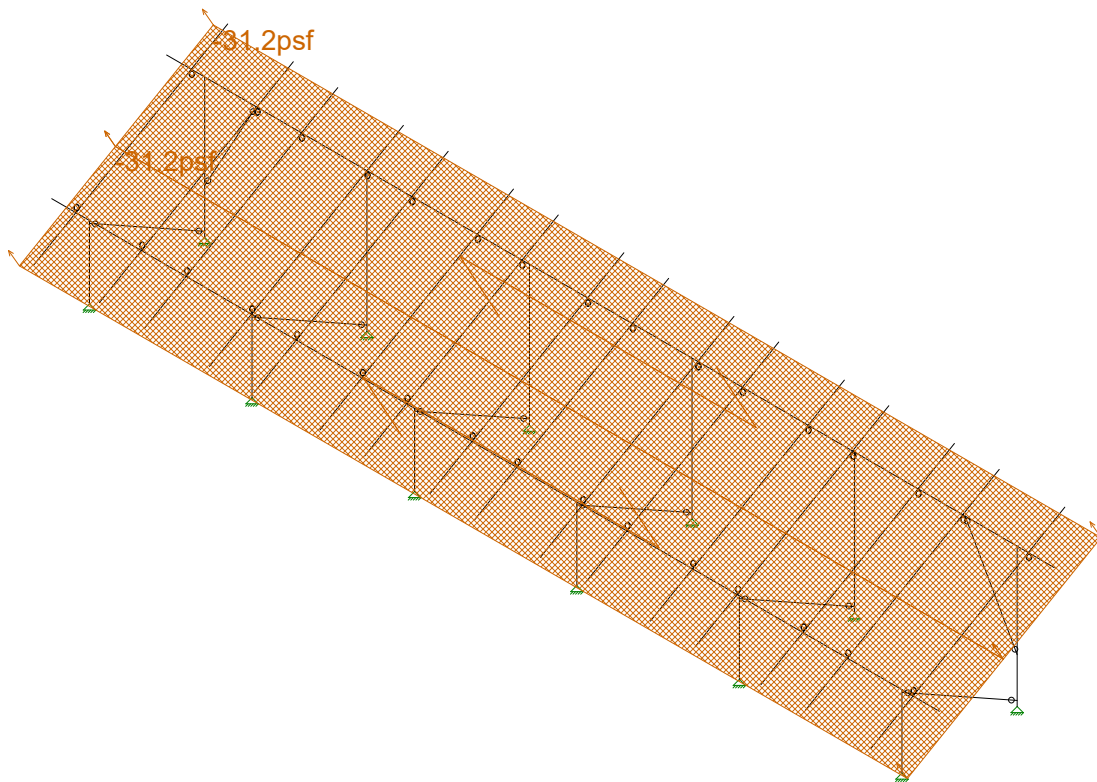

Loads: BLC 4, Wind A 0 deg

Vector Structural Engineeri..

STB

U2716.094.191

Ground Mount

SK - 7

June 7, 2019 at 3:56 PM

USA B1 GM v3.r3d

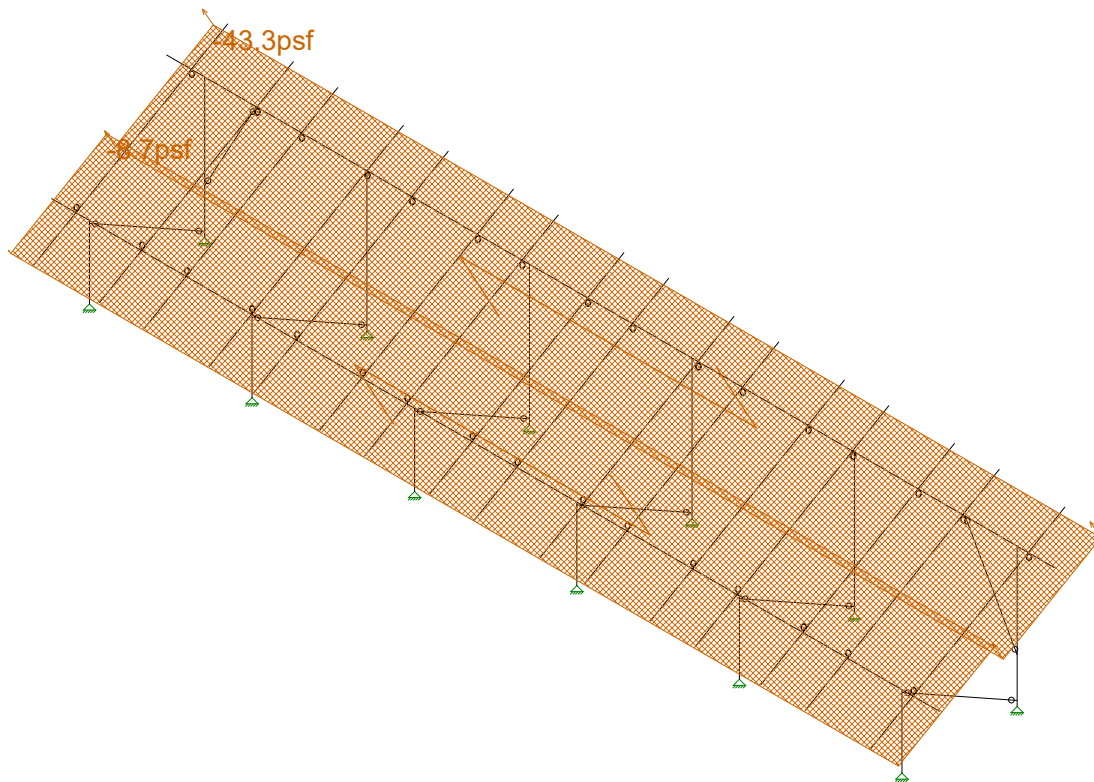

Loads: BLC 5, Wind B 0 deg

Vector Structural Engineeri..	Ground Mount	SK - 8
STB		June 7, 2019 at 3:56 PM
U2716.094.191		USA B1 GM v3.r3d

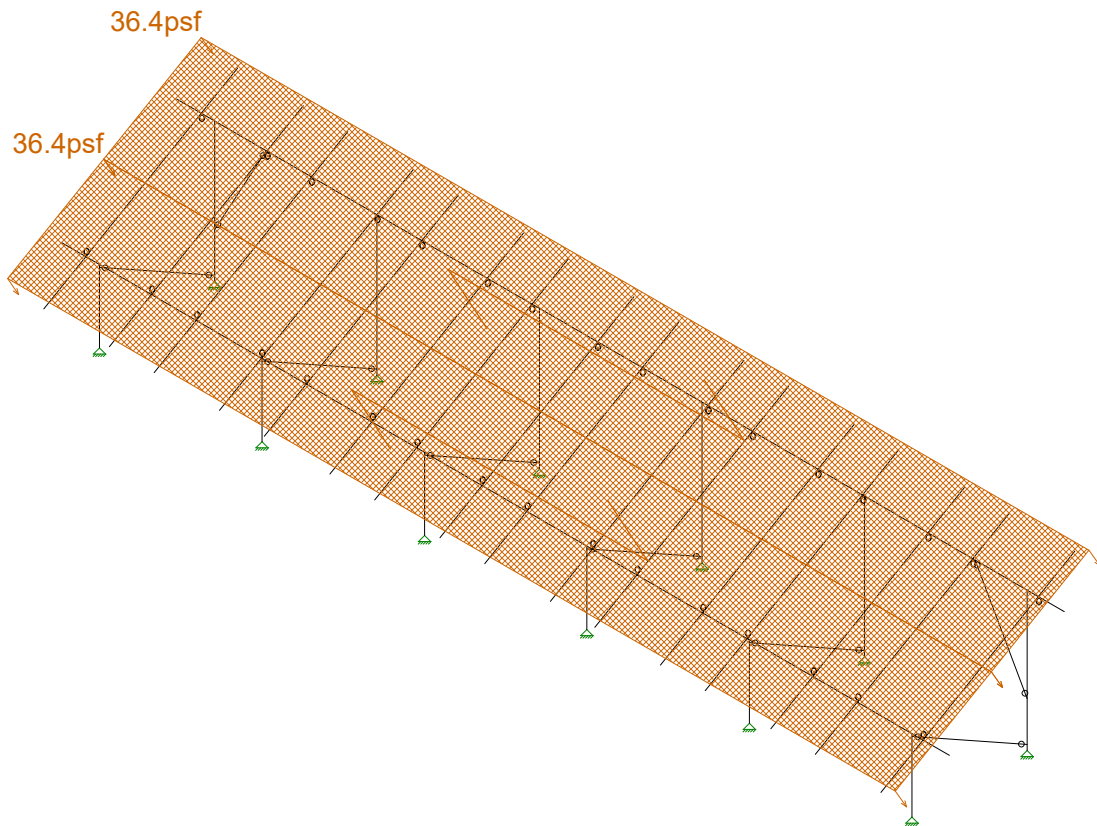

Loads: BLC 6, Wind A 180 deg

Vector Structural Engineeri..

STB

U2716.094.191

Ground Mount

SK - 9

June 7, 2019 at 3:56 PM

USA B1 GM v3.r3d

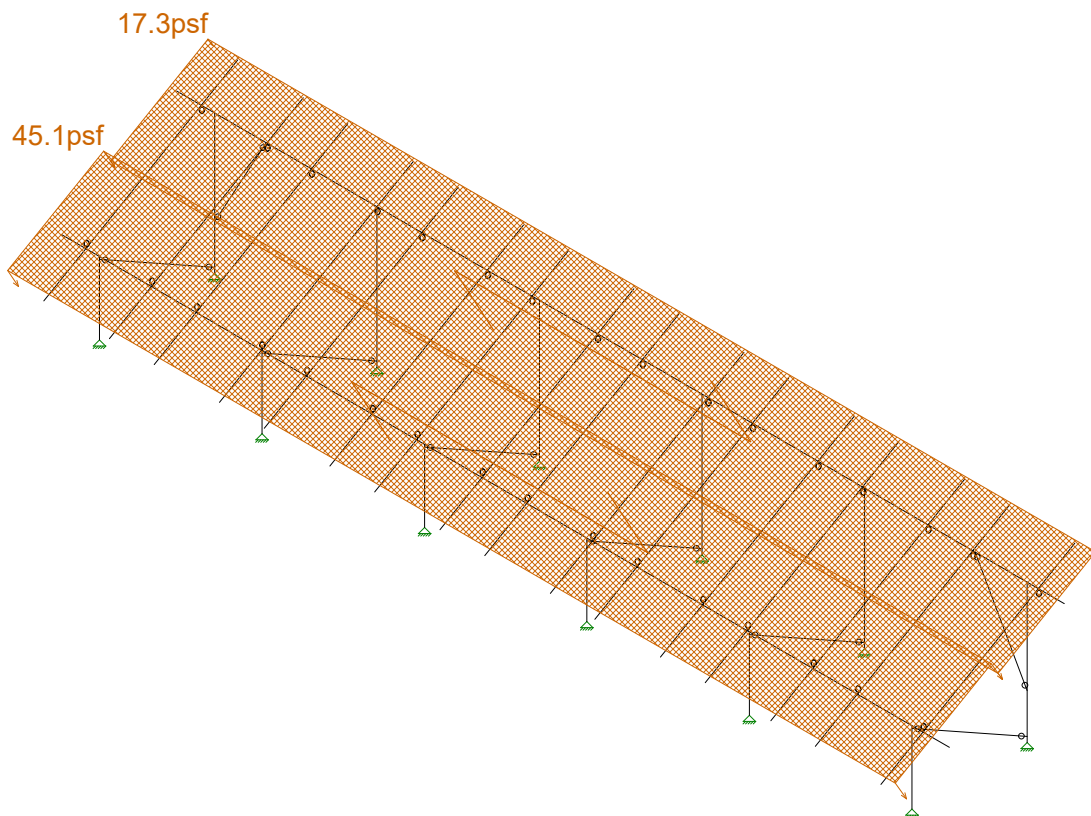

Loads: BLC 7, Wind B 180 deg

Vector Structural Engineeri..

STB

U2716.094.191

Ground Mount

SK - 10

June 7, 2019 at 3:56 PM

USA B1 GM v3.r3d

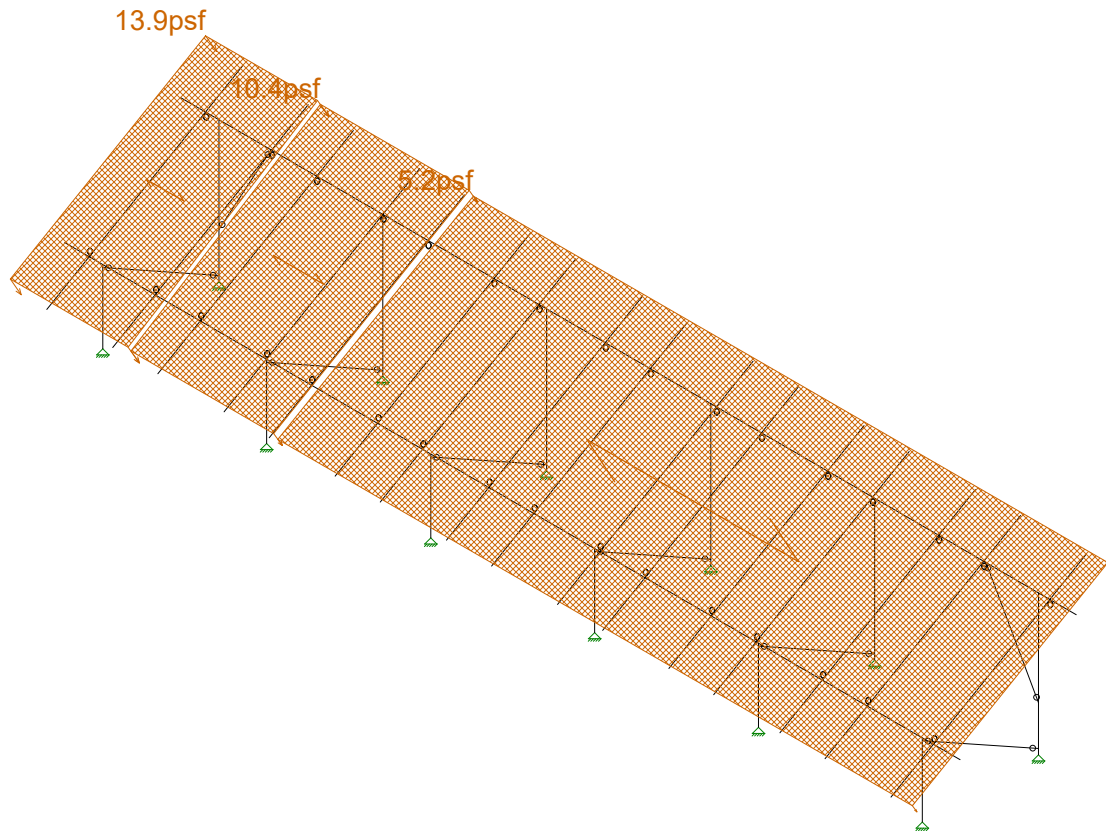

Loads: BLC 8, Wind A 90

Vector Structural Engineeri..	Ground Mount	SK - 13
STB		June 7, 2019 at 3:56 PM
U2716.094.191		USA B1 GM v3.r3d

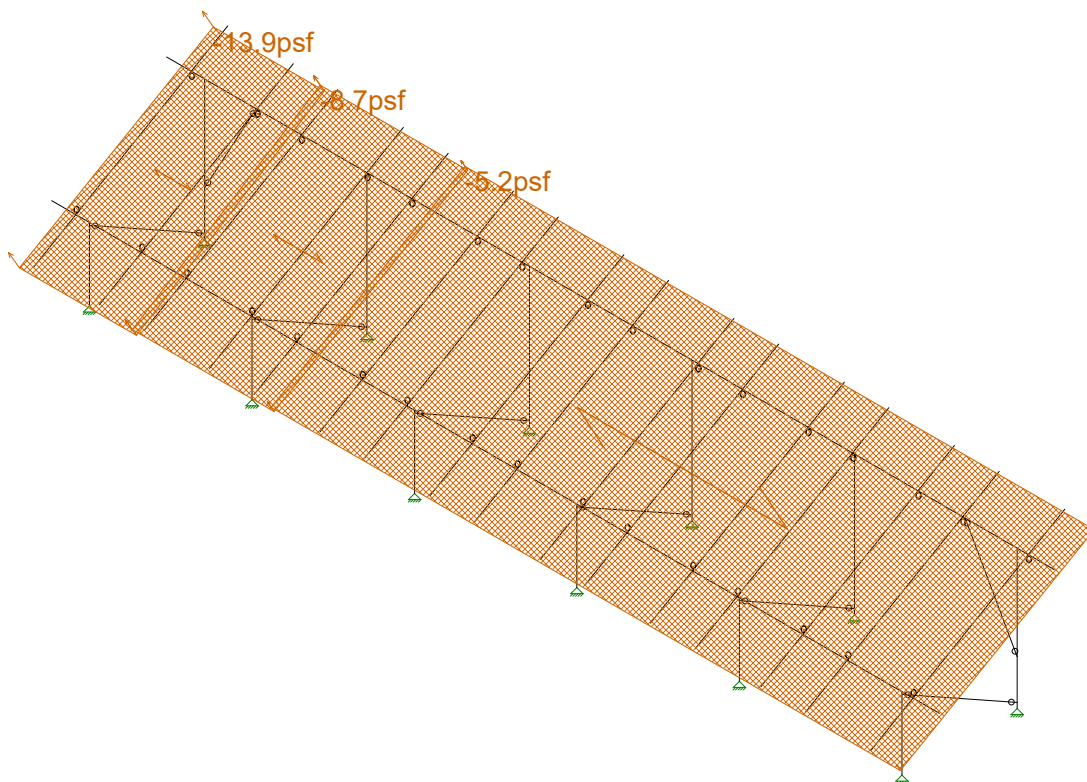

Loads: BLC 9, Wind B 90

Vector Structural Engineeri..	Ground Mount	SK - 12
STB		June 7, 2019 at 3:56 PM
U2716.094.191		USA B1 GM v3.r3d

(Global) Model Settings

Display Sections for Member Calcs	5
Max Internal Sections for Member Calcs	97
Include Shear Deformation?	Yes
Increase Nailing Capacity for Wind?	Yes
Include Warping?	Yes
Trans Load Btwn Intersecting Wood Wall?	Yes
Area Load Mesh (in^2)	144
Merge Tolerance (in)	.12
P-Delta Analysis Tolerance	0.50%
Include P-Delta for Walls?	Yes
Automatically Iterate Stiffness for Walls?	Yes
Max Iterations for Wall Stiffness	3
Gravity Acceleration (in/sec^2)	386.4
Wall Mesh Size (in)	24
Eigensolution Convergence Tol. (1.E-)	4
Vertical Axis	Y
Global Member Orientation Plane	XZ
Static Solver	Sparse Accelerated
Dynamic Solver	Accelerated Solver

Hot Rolled Steel Code	AISC 14th(360-10): ASD
Adjust Stiffness?	Yes(Iterative)
RISAConnection Code	AISC 14th(360-10): ASD
Cold Formed Steel Code	AISI S100-16: ASD
Wood Code	AWC NDS-15: ASD
Wood Temperature	< 100F
Concrete Code	ACI 318-14
Masonry Code	ACI 530-13: ASD
Aluminum Code	AA ADM1-15: ASD - Building AISC 14th(360-10): ASD

Number of Shear Regions	4
Region Spacing Increment (in)	4
Biaxial Column Method	Exact Integration
Parme Beta Factor (PCA)	.65
Concrete Stress Block	Rectangular
Use Cracked Sections?	Yes
Use Cracked Sections Slab?	No
Bad Framing Warnings?	No
Unused Force Warnings?	Yes
Min 1 Bar Diam. Spacing?	No
Concrete Rebar Set	REBAR SET ASTMA615
Min % Steel for Column	1
Max % Steel for Column	8

(Global) Model Settings, Continued

Seismic Code	ASCE 7-10
Seismic Base Elevation (in)	15600
Add Base Weight?	Yes
Ct X	.02
Ct Z	.02
T X (sec)	Not Entered
T Z (sec)	Not Entered
R X	3
R Z	3
Ct Exp. X	.75
Ct Exp. Z	.75
SD1	1
SDS	1
S1	1
TL (sec)	5
Risk Cat	I or II
Drift Cat	Other
Om Z	1
Om X	1
Cd Z	4
Cd X	4
Rho Z	1
Rho X	1

Hot Rolled Steel Properties

	Label	E [ksi]	G [ksi]	Nu	Therm (1E5 F)	Density[lb/ft^3]	Yield[psi]	Ry	Fu[psi]	Rt
1	A992	29000	11154	.3	.65	490	50000	1.1	65000	1.1
2	A36 Gr.36	29000	11154	.3	.65	490	36000	1.5	58000	1.2
3	A572 Gr.50	29000	11154	.3	.65	490	50000	1.1	65000	1.1
4	A500 Gr.B R...	29000	11154	.3	.65	527	42000	1.4	58000	1.3
5	A500 Gr.B Re...	29000	11154	.3	.65	527	46000	1.4	58000	1.3
6	A53 Gr.B	29000	11154	.3	.65	490	35000	1.6	60000	1.2
7	A1085	29000	11154	.3	.65	490	50000	1.4	65000	1.3

Aluminum Properties

	Label	E [ksi]	G [ksi]	Nu	Therm (...Density[... Table B.4	kt	Ftu[psi]	Fty[psi]	Fcy[psi]	Fsu[psi]	Ct
1	3003-H14	10100	3787.5	.33	1.3 172.8 Table B.4-1	1	19000	16000	13000	12000	141
2	6061-T6	10100	3787.5	.33	1.3 172.8 Table B.4-2	1	38000	35000	35000	24000	141
3	6063-T5	10100	3787.5	.33	1.3 172.8 Table B.4-2	1	22000	16000	16000	13000	141
4	6063-T6	10100	3787.5	.33	1.3 172.8 Table B.4-2	1	30000	25000	25000	19000	141
5	5052-H34	10200	3787.5	.33	1.3 172.8 Table B.4-1	1	34000	26000	24000	20000	141
6	6061-T6 W	10100	3787.5	.33	1.3 172.8 Table B.4-1	1	24000	15000	15000	15000	141
7	6005-T5	10100	3787.5	.33	1.3 172.8 Table B.4-1	1	38000	35000	35000	24000	141

Hot Rolled Steel Section Sets

	Label	Shape	Type	Design List	Material	Design R...	A [in2]	Iyy [in4]	Izz [in4]	J [in4]
1	Post	Pipe 2.0 A21165	Column	Pipe	A572 Gr.50	Typical	.776	.499	.499	.998
2	Cross Beam	Pipe 2.5 A21168	Beam	Wide Flange	A572 Gr.50	Typical	.947	.907	.907	1.814
3	Diagonal Brace	1.5x1.5x0.083	Beam	Wide Flange	A36 Gr.36	Typical	.47	.158	.158	.236



Company : Vector Structural Engineering
 Designer : STB
 Job Number : U2716.094.191
 Model Name : Ground Mount

July 25, 2019
 4:27 PM
 Checked By: _____

Aluminum Section Sets

	Label	Shape	Type	Design List	Material	Design R...	A [in2]	Iyy [in4]	Izz [in4]	J [in4]
1	AL Posts	2.375ODX0.188	Column	Pipe	6005-T5	Typical	1.29	.778	.778	1.54
2	AL Brace	RT1.5x2x0.15625	VBrace	Rectangular Tubes	6005-T5	Typical	.996	.327	.524	.602
3	AL Rails	HR250 ALA	Beam	Rectangular Tubes	6005-T5	Typical	.723	.095	.486	.261
4	AL Cross Beam	Cross Rail	Beam	Rectangular Tubes	6005-T5	Typical	1.909	1.97	4.366	4.017

Member Area Loads (BLC 2 : Solar Panel Weight)

	Joint A	Joint B	Joint C	Joint D	Direction	Distribution	Magnitude[psf]
1	N197	N200	N199	N196	Y	A-B	-3

Member Area Loads (BLC 3 : Roof Live/Snow)

	Joint A	Joint B	Joint C	Joint D	Direction	Distribution	Magnitude[psf]
1	N197	N200	N199	N196	PY	A-B	-13

Member Area Loads (BLC 4 : Wind A 0 deg)

	Joint A	Joint B	Joint C	Joint D	Direction	Distribution	Magnitude[psf]
1	N197	N200	N201	N198	Perp	A-B	-31.2
2	N198	N201	N199	N196	Perp	A-B	-31.2

Member Area Loads (BLC 5 : Wind B 0 deg)

	Joint A	Joint B	Joint C	Joint D	Direction	Distribution	Magnitude[psf]
1	N197	N200	N201	N198	Perp	A-B	-43.3
2	N198	N201	N199	N196	Perp	A-B	-8.7

Member Area Loads (BLC 6 : Wind A 180 deg)

	Joint A	Joint B	Joint C	Joint D	Direction	Distribution	Magnitude[psf]
1	N197	N200	N201	N198	Perp	A-B	36.4
2	N198	N201	N199	N196	Perp	A-B	36.4

Member Area Loads (BLC 7 : Wind B 180 deg)

	Joint A	Joint B	Joint C	Joint D	Direction	Distribution	Magnitude[psf]
1	N197	N200	N201	N198	Perp	A-B	17.3
2	N198	N201	N199	N196	Perp	A-B	45.1

Member Area Loads (BLC 8 : Wind A 90)

	Joint A	Joint B	Joint C	Joint D	Direction	Distribution	Magnitude[psf]
1	N197	N203	N202	N196	Perp	A-B	13.9
2	N203	N209	N208	N202	Perp	A-B	10.4
3	N209	N200	N199	N208	Perp	A-B	5.2

Member Area Loads (BLC 9 : Wind B 90)

	Joint A	Joint B	Joint C	Joint D	Direction	Distribution	Magnitude[psf]
1	N197	N203	N202	N196	Perp	A-B	-13.9
2	N203	N209	N208	N202	Perp	A-B	-8.7
3	N209	N200	N199	N208	Perp	A-B	-5.2

Basic Load Cases

	BLC Description	Category	X Gravity	Y Gravity	Z Gravity	Joint	Point	Distributed	Area(M...Surface...
1	Self Weight	DL		-1.05					
2	Solar Panel Weight	DL							1



Company : Vector Structural Engineering
 Designer : STB
 Job Number : U2716.094.191
 Model Name : Ground Mount

July 25, 2019
 4:27 PM
 Checked By: _____

Envelope AA ADM1-15: ASD - Building Aluminum Code Checks (Continued)

Member	Shape	Code C...	Loc[in]	LC Shear ...	Loc[in]	Dir	LC Pnc/O...	Pnt/Om...	Mny/O...	Mnz/O...	Vny/O...	Vnz/O...	Cb	Eqn
12	M62	HR250_A...	.763	36.144	12	.081	37.865	y	12	2221.164	14089....	309.506	613.954	5108.7271672.364 1 H.1-1
13	M65	HR250_A...	.763	36.144	12	.082	37.865	y	12	2221.164	14089....	309.506	613.954	5108.7271672.364 1 H.1-1
14	M68B	HR250_A...	.974	89.499	16	.082	37.865	y	12	2221.164	14089....	309.506	613.954	5108.7271672.364 1 H.1-1
15	M71A	HR250_A...	.763	36.144	12	.090	37.865	y	12	2221.164	14089....	309.506	613.954	5108.7271672.364 1 H.1-1
16	M69C	RT1.5x2x...	.287	47.196	11	.011	0	z	12	2657.816	19411....	770.742	927.083	6090.1994101.5631... H.1-1
17	M71B	HR250_A...	.833	87.778	11	.097	37.865	y	12	2221.164	14089....	309.506	613.954	5108.7271672.364 1 H.1-1
18	M74	HR250_A...	.837	36.144	12	.088	37.865	y	12	2221.164	14089....	309.506	613.954	5108.7271672.364 1 H.1-1

NOTES: UNLESS OTHERWISE SPECIFIED
 1. DIMENSIONS SHOWN ARE INCHES [MILLIMETERS].

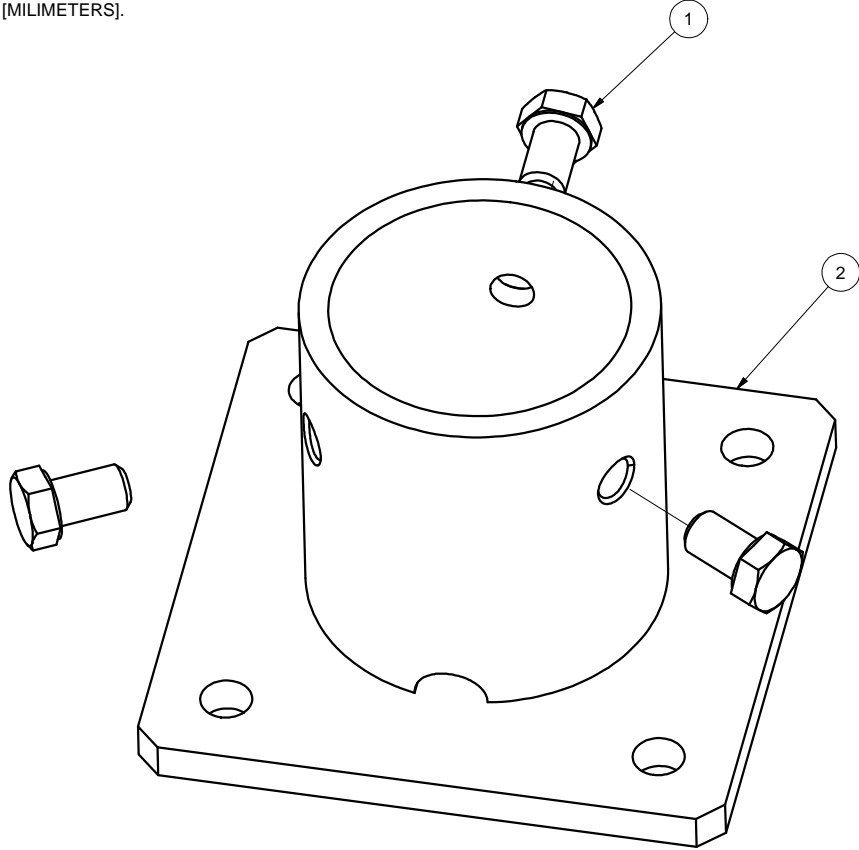

REVISIONS			
REV	DESCRIPTION	BY	DATE
A	INITIAL RELEASE	LWF	10/20/2016

2	A21120-001	2" PIPE BASE	1
1	B15018-011	HEX CAP SCREW 3/8-16 X 5/8	3
ITEM	PART NUMBER	DESCRIPTION	QTY
MATERIAL		SEE NOTES	
Third Angle Projection:			
GENERAL SPECIFICATIONS		Sunmodo Corp. 1905 E 5TH STREET, STE A, VANCOUVER, WA 98661	
Tolerances		TITLE	
X.XXX ±0.01 [0.25mm] X.XX ±0.02 [0.50mm] X.X ±0.039 [1.0mm] Unless otherwise spec'd		2" PIPE BASE KIT	
DRAWN BY		DATE	
LWF		10/20/2016	
CHECKED BY		DRAWING NUMBER	
		B K10268-001	
APPROVALS		SCALE: NONE SHEET 1 of 1	

THIS DRAWING IS CONFIDENTIAL PROPERTY OF SUNMODO AND ITS CONTENTS MAY NOT BE DISCLOSED WITHOUT THE PRIOR WRITTEN CONSENT OF SUNMODO CORP.

NOTES: UNLESS OTHERWISE SPECIFIED

1. DIMENSIONS SHOWN ARE INCHES [MILIMETERS].
2. MATERIAL: ALUMINUM 6005-T5.
FINISH: CLEAR ANODIZED 10 μ m THICK.
3. THE UNSPECIFIED DIMENSIONS ARE SPECIFIED BY 2D CAD FILE.

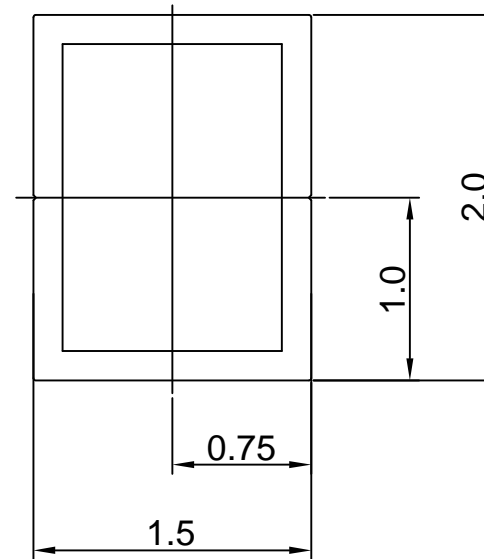

Section properties:

Weight: 1.156 lbs/ft

Area: 0.992 in²

Perimeter: 12.601 in

Bounding Box: X: -1.000,1.000

Y: -0.750, 0.750

Centroid:(0.000,0.000)

Moments of Inertia(in⁴): I_x=0.506,I_y=0.322

Section modulus in bending(in³): W_x=0.675,W_y=0.322

Radii of Gyration: X: 0.714, Y: 0.570

MATERIAL		SEE NOTES	
Third Angle Projection:			
GENERAL SPECIFICATIONS			
All Dimensions in inches [millimeters]			
Tolerances			
X.XXX ± 0.01 [0.25mm]		Break all sharp edges	
X.XX ± 0.02 [0.50mm]		.010-.020 unless	
X.X ± 0.039 [1.0mm]		otherwise specified.	
Unless otherwise specified			
DRAWN BY	DATE		
zcg	03/12/2014		
CHECKED BY			
		B	DRAWING NUMBER A20164
APPROVALS		SCALE: NONE	SHEET 1 of 1

Sunmodo Corp.

1905 E 5TH STREET, SUITE A, VANCOUVER, WA 98661

TITLE
1.5X2 AL TUBE BRACE EXTRUSION

REVISIONS			
REV	DESCRIPTION	BY	DATE
A	ADDED BOTTOM CHANNEL & CHANGED ONE 3/8 CHANNEL TO 1/4	zcg	02/21/2013

NOTES: UNLESS OTHERWISE SPECIFIED

1. DIMENSIONS SHOWN ARE INCHES [MILIMETERS].
2. MATERAIL: ALUMINUM 6005-T5.
FINISH: CLEAR ANODIZED 15 μm THICK.
3. THE UNSPECIFIED DIMENSIONS ARE SPECIFIED BY 2D CAD FILE.

2X 1/4 BOLT SLOT

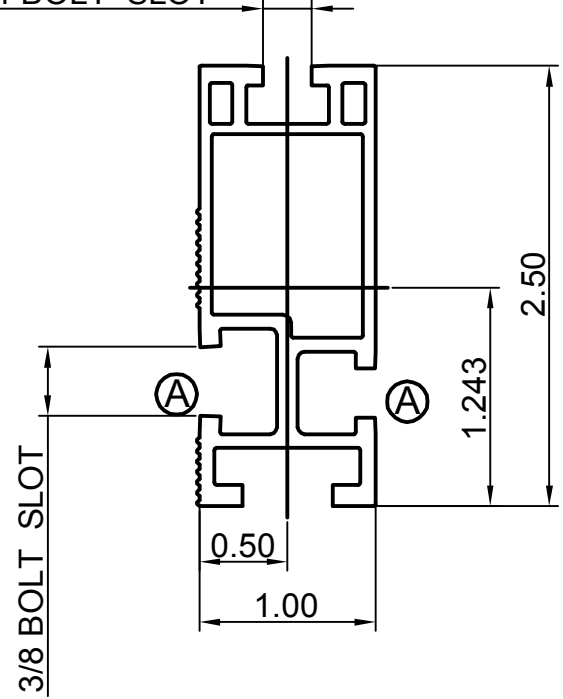

Section properties:

Weight: 0.850 lbs/ft
 Area: 0.723 in²
 Perimeter: 17.325 in
 Bounding Box: X: -0.500,0.500
 Y: -1.243,1.257

Centroid:(0.000,0.000)
 Moments of Inertia(in⁴): I_x=0.486,I_y=0.095
 Section modulus in bending(in³): W_x=0.387,W_y=0.190
 Radii of Gyration: X: 0.820, Y: 0.363

MATERIAL SEE NOTES	
Third Angle Projection:	
GENERAL SPECIFICATIONS All Dimensions in inches [millimeters]	
Tolerances	
X,XXX ± 0.01 [0.25mm]	Break all sharp edges
X,XX ± 0.02 [0.50mm]	.010-.020 unless
X,X ± 0.039 [1.0mm]	otherwise specified.
Unless otherwise spec'd	
DRAWN BY zcg	DATE 02/21/2013
CHECKED BY	
APPROVALS	

Sunmodo Corp.	
1905 E 5TH STREET, SUITE A, VANCOUVER, WA 98661	
TITLE HELIO STANDARD RAIL	
DRAWING NUMBER B A20144	
SCALE: NONE	SHEET 1 of 1

4

3

2

1

NOTES: UNLESS OTHERWISE SPECIFIED

- 1. DIMENSIONS SHOWN ARE INCHES [MILIMETERS].
- 2. MATERIAL: 6005-T5.
FINISH: CLEAR ANODIZED 10um THICK.
- 3. THE UNSPECIFIED RADII ARE .02" MAX.
- 4. THE UNSPECIFIED DIMENSIONS ARE SPECIFIED BY 2D CAD FILE.

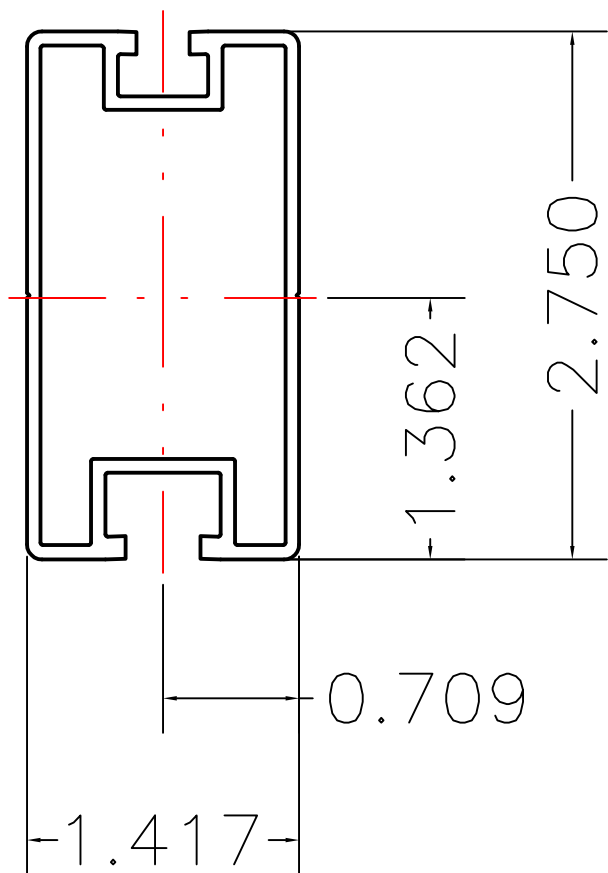

Section properties:

Weight: 0.862 lbs/ft
 Area: 0.736 in²
 Perimeter: 19.824 in
 Bounding Box: X: -0.709,0.709
 Y: -1.362,1.388
 Centroid:(0.000,0.000)
 Moments of Inertia(in⁴): Ix=0.727,Iy=0.214
 Section modulus in bending(in³): Wx=0.524,Wy=0.302
 Radii of Gyration: X: 994, Y: 0.539

MATERIAL SEE NOTES	
Third Angle Projection:	
GENERAL SPECIFICATIONS All Dimensions in inches [millimeters]	
Tolerances	
X.XXX ±0.01 [0.25mm]	Break all sharp edges .010-.020 unless otherwise specified.
X.XX ±0.02 [0.50mm]	
X.X ±0.039 [1.0mm]	
Unless otherwise spec'd	
DRAWN BY KYY	DATE 01/18/2018
CHECKED BY	
APPROVALS	

SunModo Corp.	
14800 NE 65TH STREET, VANCOUVER WA 98682	
TITLE RAIL, HR300 (SUNRAY), EXTRUSION	
B	DRAWING NUMBER A20288
SCALE: NONE	SHEET 1 of 1

THIS DRAWING IS CONFIDENTIAL PROPERTY OF SUNMODO AND ITS CONTENTS MAY NOT BE DISCLOSED WITHOUT THE PRIOR WRITTEN CONSENT OF SUNMODO CORP.

REV	DESCRIPTON	BY	DATE
A	0.44 WAS 0.41, 0.44 WAS 0.33	LWF	11/30/2015

NOTES: UNLESS OTHERWISE SPECIFIED

- 1. DIMENSIONS SHOWN ARE INCHES [MILIMETERS].
- 2. MATERIAL: ALUMINUM 6005-T5.
FINISH: CLEAR ANODIZED 15 μm THICK.
- 3. THE UNSPECIFIED DIMENSIONS ARE SPECIFIED BY 2D CAD FILE.

2X 1/4 BOLT SLOT

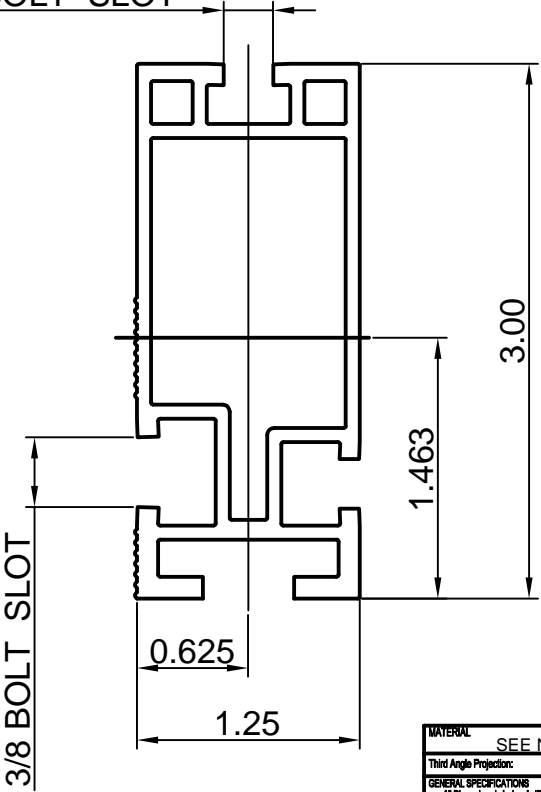

Section properties:

Weight: 1.151 lbs/ft
 Area: 0.980 in²
 Perimeter: 22.104 in
 Bounding Box: X: -0.625,0.625
 Y: -1.463,1.537
 Centroid:(0.000,0.000)
 Moments of Inertia(in⁴): Ix=1.047,Iy=0.207
 Section modulus in bending(in³): Wx=0.681,Wy=0.331
 Radii of Gyration: X: 1.034, Y: 0.460

MATERIAL		SEE NOTES	
Third Angle Projection			
GENERAL SPECIFICATIONS			
All Dimensions in Inches [millimeters]			
Tolerances			
XXX ±0.01 (0.25mm)			
XX ±0.02 (0.50mm)			
X ±0.03 (1.0mm)			
Unless otherwise specified.			
DRAWN BY		DATE	
ZCJ		02/1/2013	
CHECKED BY		DATE	
APPROVALS		DATE	
Sunmodo Corp.		1905 E 5TH STREET, SUITE A, VANCOUVER, WA 98661	
TITLE		HELIO HEAVY RAIL	
DRAWING NUMBER		A20145	
SCALE:		NONE	
SHEET		1 of 1	

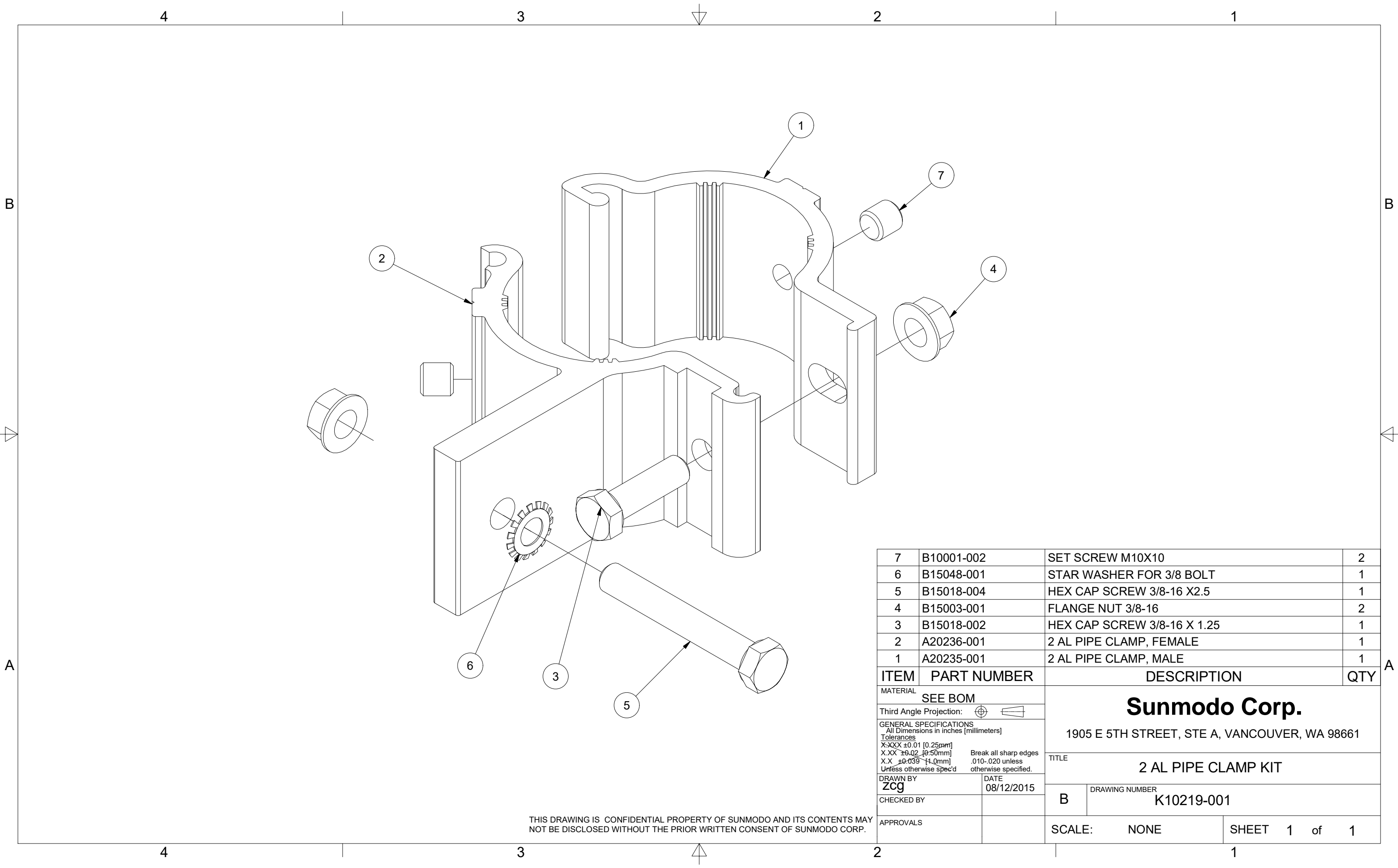

7	B10001-002	SET SCREW M10X10	2
6	B15048-001	STAR WASHER FOR 3/8 BOLT	1
5	B15018-004	HEX CAP SCREW 3/8-16 X2.5	1
4	B15003-001	FLANGE NUT 3/8-16	2
3	B15018-002	HEX CAP SCREW 3/8-16 X 1.25	1
2	A20236-001	2 AL PIPE CLAMP, FEMALE	1
1	A20235-001	2 AL PIPE CLAMP, MALE	1

ITEM	PART NUMBER	DESCRIPTION	QTY
MATERIAL		SEE BOM	
Third Angle Projection:			
GENERAL SPECIFICATIONS All Dimensions in inches (millimeters)			
Tolerances			
X.XXX ±0.01 [0.25mm]		Break all sharp edges	
X.XX ±0.02 [0.50mm]		.010-.020 unless	
X.X ±0.039 [1.0mm]		otherwise specified.	
DRAWN BY		DATE	
zcg		08/12/2015	
CHECKED BY		B	
APPROVALS		DRAWING NUMBER	
		K10219-001	
SCALE:		NONE	SHEET 1 of 1

Sunmodo Corp.
1905 E 5TH STREET, STE A, VANCOUVER, WA 98661

TITLE
2 AL PIPE CLAMP KIT

THIS DRAWING IS CONFIDENTIAL PROPERTY OF SUNMODO AND ITS CONTENTS MAY NOT BE DISCLOSED WITHOUT THE PRIOR WRITTEN CONSENT OF SUNMODO CORP.

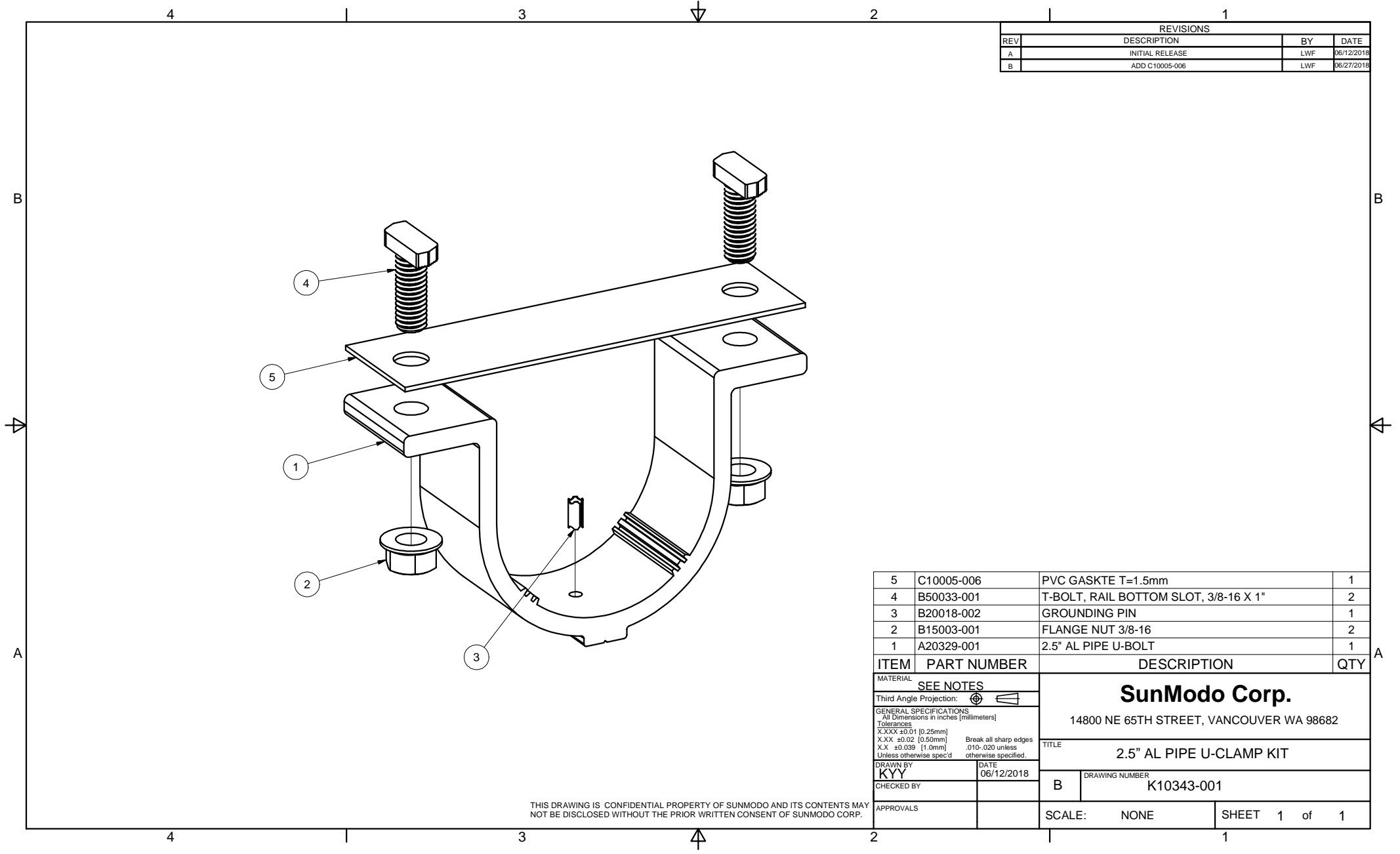

REVISIONS			
REV	DESCRIPTION	BY	DATE
A	INITIAL RELEASE	LWF	06/12/2018
B	ADD C10005-006	LWF	06/27/2018

ITEM	PART NUMBER	DESCRIPTION	QTY
5	C10005-006	PVC GASKTE T=1.5mm	1
4	B50033-001	T-BOLT, RAIL BOTTOM SLOT, 3/8-16 X 1"	2
3	B20018-002	GROUNDING PIN	1
2	B15003-001	FLANGE NUT 3/8-16	2
1	A20329-001	2.5" AL PIPE U-BOLT	1

MATERIAL		SEE NOTES	
Third Angle Projection:			
GENERAL SPECIFICATIONS		<p>SunModo Corp. 14800 NE 65TH STREET, VANCOUVER WA 98682</p>	
<p>All Dimensions in inches [millimeters]</p> <p>Tolerances</p> <p>X.XXX ±0.01 [0.25mm]</p> <p>X.XX ±0.02 [0.50mm]</p> <p>X.X ±0.039 [1.0mm]</p> <p>Unless otherwise spec'd</p>			
TITLE		2.5" AL PIPE U-CLAMP KIT	
DRAWN BY	DATE	DRAWING NUMBER	
KYY	06/12/2018	B K10343-001	
CHECKED BY			
APPROVALS		SCALE:	NONE SHEET 1 of 1

THIS DRAWING IS CONFIDENTIAL PROPERTY OF SUNMODO AND ITS CONTENTS MAY NOT BE DISCLOSED WITHOUT THE PRIOR WRITTEN CONSENT OF SUNMODO CORP.

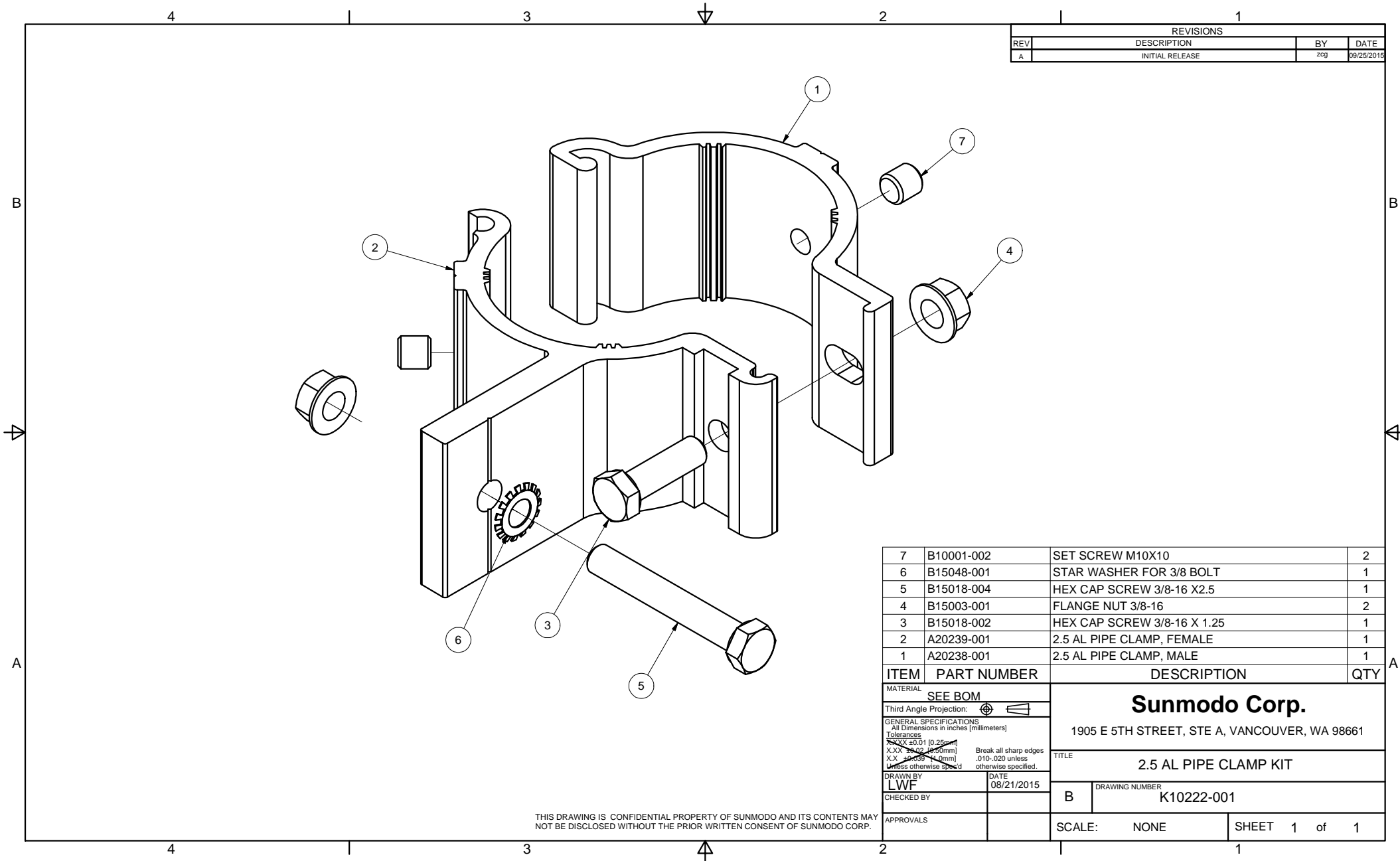

REVISIONS			
REV	DESCRIPTION	BY	DATE
A	INITIAL RELEASE	zcg	09/25/2015

7	B10001-002	SET SCREW M10X10	2
6	B15048-001	STAR WASHER FOR 3/8 BOLT	1
5	B15018-004	HEX CAP SCREW 3/8-16 X2.5	1
4	B15003-001	FLANGE NUT 3/8-16	2
3	B15018-002	HEX CAP SCREW 3/8-16 X 1.25	1
2	A20239-001	2.5 AL PIPE CLAMP, FEMALE	1
1	A20238-001	2.5 AL PIPE CLAMP, MALE	1
ITEM	PART NUMBER	DESCRIPTION	QTY

MATERIAL		SEE BOM	
Third Angle Projection:			
GENERAL SPECIFICATIONS All Dimensions in inches [millimeters] Tolerances X.XX ±0.01 [0.25mm] X.X ±0.02 [0.5mm] X.X ±0.03 [0.75mm] Unless otherwise specified, Break all sharp edges .010-.020 unless otherwise specified.			
DRAWN BY	DATE	TITLE	
LWF	08/21/2015	2.5 AL PIPE CLAMP KIT	
CHECKED BY		DRAWING NUMBER	
		B	K10222-001
APPROVALS		SCALE:	NONE SHEET 1 of 1

THIS DRAWING IS CONFIDENTIAL PROPERTY OF SUNMODO AND ITS CONTENTS MAY NOT BE DISCLOSED WITHOUT THE PRIOR WRITTEN CONSENT OF SUNMODO CORP.

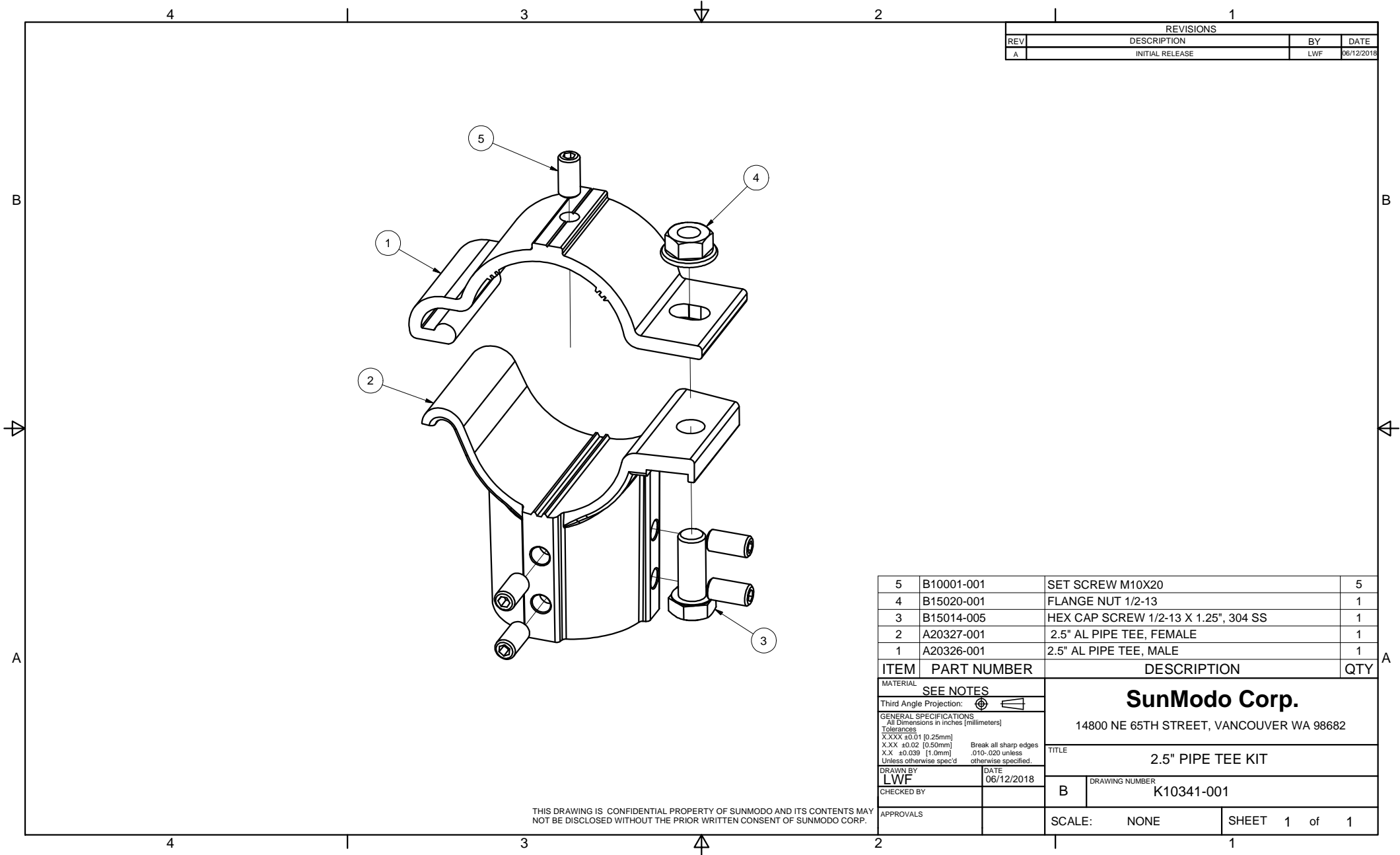

REVISIONS			
REV	DESCRIPTION	BY	DATE
A	INITIAL RELEASE	LWF	06/12/2018

ITEM	PART NUMBER	DESCRIPTION	QTY
5	B10001-001	SET SCREW M10X20	5
4	B15020-001	FLANGE NUT 1/2-13	1
3	B15014-005	HEX CAP SCREW 1/2-13 X 1.25", 304 SS	1
2	A20327-001	2.5" AL PIPE TEE, FEMALE	1
1	A20326-001	2.5" AL PIPE TEE, MALE	1

MATERIAL		SEE NOTES	
Third Angle Projection:			
GENERAL SPECIFICATIONS		SunModo Corp. 14800 NE 65TH STREET, VANCOUVER WA 98682	
Tolerances		TITLE	
X.XXX ±0.01 [0.25mm] X.XX ±0.02 [0.50mm] X.X ±0.039 [1.0mm] Unless otherwise spec'd		2.5" PIPE TEE KIT	
DRAWN BY		DATE	DRAWING NUMBER
LWF		06/12/2018	B K10341-001
CHECKED BY		SCALE: NONE SHEET 1 of 1	
APPROVALS			

THIS DRAWING IS CONFIDENTIAL PROPERTY OF SUNMODO AND ITS CONTENTS MAY NOT BE DISCLOSED WITHOUT THE PRIOR WRITTEN CONSENT OF SUNMODO CORP.

REVISIONS			
REV	DESCRIPTION	BY	DATE
A	INITIAL RELEASE	LWF	06/12/2018

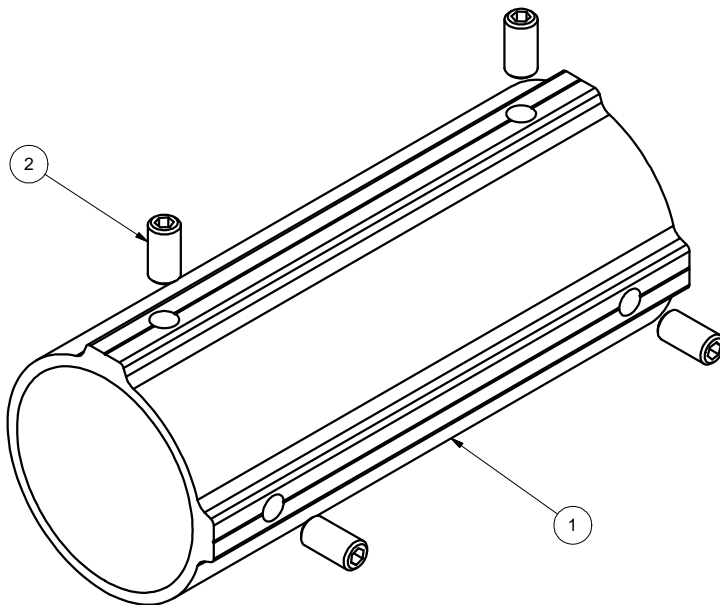

2	B10001-001	SET SCREW M10X20	4
1	A20328-001	2.5" PIPE SPLICE	1
ITEM	PART NUMBER	DESCRIPTION	QTY
MATERIAL		SEE NOTES	
Third Angle Projection:			
GENERAL SPECIFICATIONS		SunModo Corp. 14800 NE 65TH STREET, VANCOUVER WA 98682	
All Dimensions in inches [millimeters] Tolerances X.XXX ±0.01 [0.25mm] X.XX ±0.02 [0.50mm] X.X ±0.039 [1.0mm] Unless otherwise spec'd		Break all sharp edges .010-.020 unless otherwise specified.	
DRAWN BY		TITLE	
LWF		2.5" PIPE SPLICE KIT	
CHECKED BY		DRAWING NUMBER	
		B K10342-001	
APPROVALS		SCALE: NONE SHEET 1 of 1	

THIS DRAWING IS CONFIDENTIAL PROPERTY OF SUNMODO AND ITS CONTENTS MAY NOT BE DISCLOSED WITHOUT THE PRIOR WRITTEN CONSENT OF SUNMODO CORP.

NOTES: UNLESS OTHERWISE SPECIFIED

1. DIMENSIONS SHOWN ARE INCHES [MILIMETERS].
2. MATERIAL: HIGH STRENGTH STEEL PIPE OR TUBE.
3. FINISH: HOT DIP GALVANIZE PER ASTM A123 / A123M - 02.

MINIMUM 50 KSI YIELD STRESS.

4. BREAK ALL BURRS AND SHARP EDGES.

5. ALL WELDING MUST BE IN COMPLIANCE WITH AWS CODE D1;1.

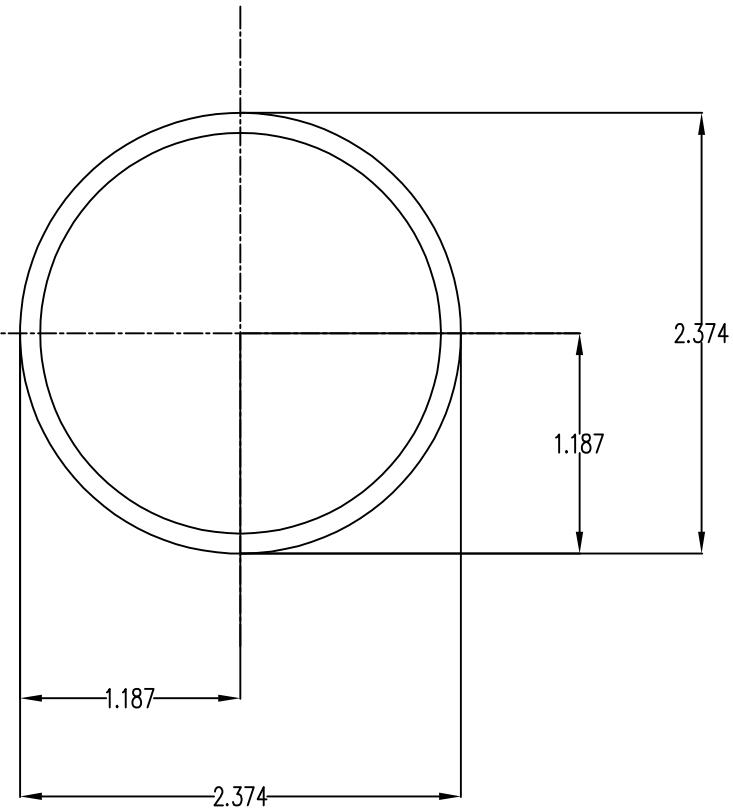

Section properties:

Weight: 2.641 lbs/ft

Area: 0.776 in²

Perimeter: 14.238 in

Bounding Box: X: -1.187, 1.187

Y: -1.187, 1.187

Centroid: (0.000, 0.000)

Moments of Inertia (in⁴): I_x=0.499, I_y=0.499

Section modulus in bending (in³): W_x=0.420, W_y=0.420

Radii of Gyration: X: 0.802, Y: 0.802

MATERIAL		SEE NOTES		Sunmodo Corp. 14800 NE 85TH STREET, VANCOUVER WA 98682	
Third Angle Projection:					
GENERAL SPECIFICATIONS				TITLE	
All Dimensions in Inches (millimeters)				PIPE, HSS, 2.375" OD X 12 GAUGE, L=XXX	
Tolerances				Break all sharp edges .010-.020 unless otherwise specified.	
XXX ±0.01 (0.25mm)					
XX ±0.02 (0.50mm)					
X ±0.050 (1.27mm)					
Unless otherwise specified					
DRAWN BY	DATE	B		DRAWING NUMBER	
LWF	04/03/2019			A21165	
CHECKED BY					
APPROVALS				SCALE: NONE SHEET 1 of 1	

NOTES: UNLESS OTHERWISE SPECIFIED

1. DIMENSIONS SHOWN ARE INCHES [MILIMETERS].
2. MATERAIL:HIGH STRENGTH STEEL PIPE OR TUBE.
3. FINISH: HOT DIP GALVANIZE PER ASTM A123 / A123M - 02.

MINIMUM 50 KSI YIELD STRESS.

4. BREAK ALL BURRS AND SHARP EDGES.
5. ALL WELDING MUST BE IN COMPLIANCE WITH AWS CODE D1;1.

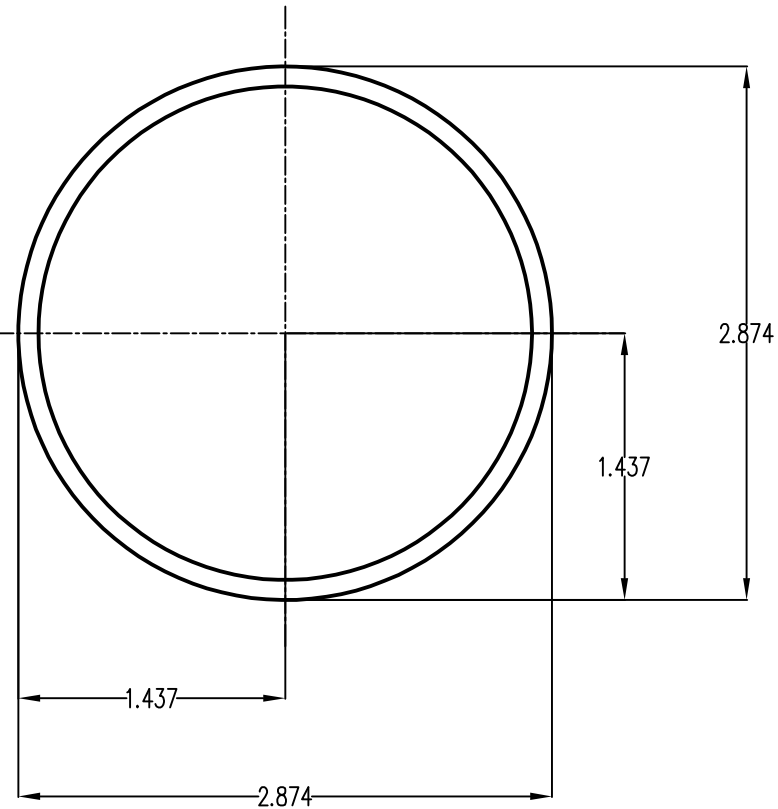

Section properties:

Weight: 3.201 lbs/ft

Area: 0.941 in²

Perimeter: 17.378 in

Bounding Box: X: -1.437,1.437

Y: -1.437,1.437

Centroid:(0.000,0.000)

Moments of Inertia(in⁴): Ix=0.901,Iy=0.901

Section modulus in bending(in³): Wx=0.627,Wy=0.627

Radii of Gyration: X: 0.979, Y: 0.979

MATERIAL		SEE NOTES		Sunmodo Corp.	
Third Angle Projection:					
GENERAL SPECIFICATIONS				14800 NE 85TH STREET, VANCOUVER WA 98682	
All Dimensions in Inches (millimeters)				TITLE	
Tolerances				PIPE, HSS, 2.875" OD X 12 GAUGE,L=XXX	
XXX ±0.01 (0.25mm)				Break all sharp edges .010-.020 unless otherwise specified.	
XX ±0.02 (0.50mm)				DRAWING NUMBER	
X ±0.050 (1.2mm)				B A21168	
Unless otherwise specified				APPROVALS	
DRAWN BY		DATE		SCALE: NONE	
LWF		04/03/2019		SHEET 1 of 1	
CHECKED BY					