

STRUCTURAL ONLY



651 W. GALENA PARK BLVD. STE. 101 DRAPER, UTAH 84020  
 PHONE (801) 990-1775  
 WWW.VECTORSE.COM

NOTES: UNLESS OTHERWISE SPECIFIED

- THIS DRAWING IS NOT FOR CONSTRUCTION UNTIL ENGINEERING HAS REVIEWED AND STAMPED THIS DOCUMENT.
- DIMENSIONS SHOWN ARE INCHES.
- THE SELF-BONDING SYSTEM AND SINGLE GROUND LUG IS FOR USE WITH PV MODULES THAT HAVE A MAXIMUM SERIES FUSE RATING OF 30A.
- MATERIALS ARE AS SPECIFIED OR EQUIVALENT:  
 HARDWARE: 304 STAINLESS STEEL  
 FABRICATED EXTRUDED PARTS: 6005-T5 ALUMINUM ALLOY  
 FABRICATED DIE CAST PARTS: ANSI/AA A380 ALUMINUM ALLOY  
 STEEL PIPE: SCHEDULE 40 GALVANIZED  
 ALUMINUM PIPE: SCHEDULE 10 ANODIZED
- THE MAXIMUM PERMISSIBLE LENGTH OF ANY STRUCTURE SHALL BE 200 FT. FOR SYSTEMS USING A SHARED RAIL CONFIGURATION, A THERMAL BREAK IS REQUIRED IN THE RAIL EVERY 40 FT. PER THE DRAWING DETAILS.
- 4LXN-3LXN-2PXN-30DEG-GSM-AGM-BGM-PGM.
- PANEL DIMENSIONS ARE AS FOLLOWS  
 STANDARD (SP): MAX 82"X42"  
 OVERSIZE (OP): MAX 85"X45"
- APPROVED RAIL PROFILES - STANDARD PANELS  
 A20144-XXX (HR250 RAIL), A20284-001 (END CAP), K10343-001 (U-CLAMP KIT);  
 A20288-XXX (HR300 RAIL), A20297-001 (END CAP), K10343-002 (U-CLAMP KIT);  
 A20145-XXX (HR350 RAIL), A20285-001 (END CAP), K10343-001 (U-CLAMP KIT).
- APPROVED RAIL PROFILES - OVERSIZE PANELS  
 \* A20288-XXX (HR300 RAIL), A20297-001 (END CAP), K10343-002 (U-CLAMP KIT);  
 \* A20145-XXX (HR350 RAIL), A20285-001 (END CAP), K10343-001 (U-CLAMP KIT).
- K10224-XXX END CLAMP KIT OR K10299-XXX AD. END CLAMP KIT.
- FOUNDATION TYPES:  
 GSM = GROUND SCREW GROUND MOUNT  
 AGM = HELICAL AUGER GROUND MOUNT  
 PGM = POST-IN-CONCRETE GROUND MOUNT  
 BSM = BALLAST GROUND MOUNT

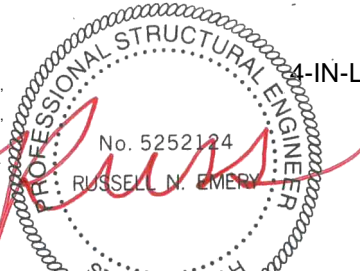
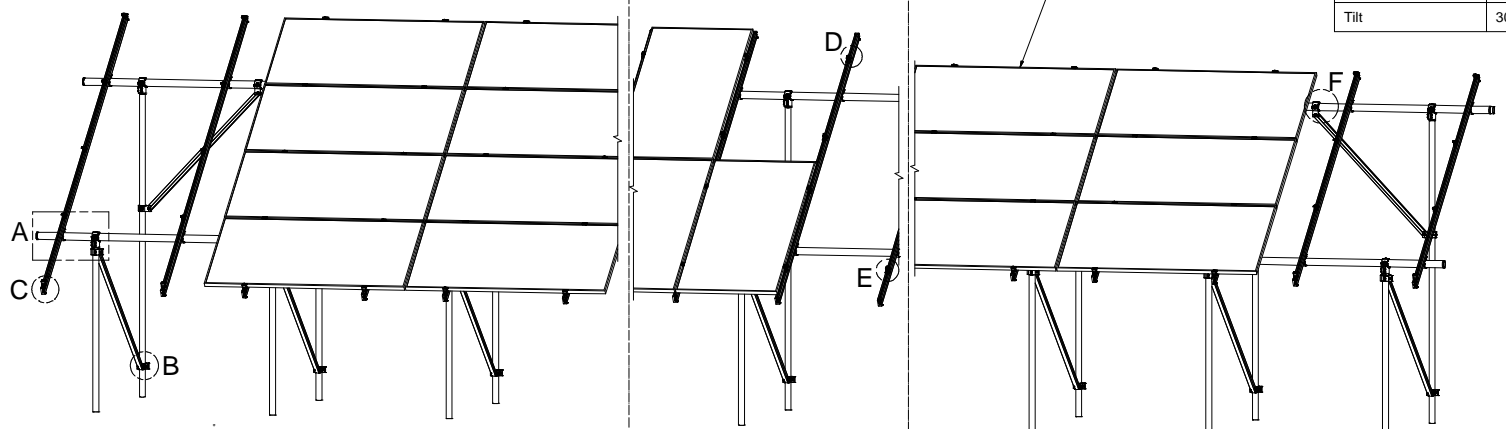

Packet B3	
Model Code	ASCE 7-16
Exposure Category	C and Lower
Wind Speed	105 mph and Lower
Ground Snow Load	30 PSF and Lower
Tilt	30 DEG and Lower

19	PANEL		
18	HELIO-RAIL-VARIES PER NOTE 8 & 9		
17	HELIO-RAIL END CAP-VARIES PER NOTE 8 & 9		
16	END CLAMP KIT. VARIES PER NOTE 10		
15	K10343-001 2.5" AL PIPE U-CLAMP KIT		
14	K10448-001 2.5" PIPE SPLICE KIT		
13	K10342-001 2.5" PIPE SPLICE KIT		
12	K10341-001 2.5" PIPE TEE KIT		
11	K10222-001 2.5" PIPE CLAMP KIT		
10	K10219-001 2" AL PIPE CLAMP KIT		
9	K10183-XXX LANDSCAPE GROUNDING END CLAMP KIT		
8	K10182-001 LANDSCAPE GROUNDING MID CLAMP KIT		
7	K10180-001 GROUNDING MID-CLAMP KIT WITH T COLLAR BOLT AND GROUNDING BASE		
6	K10179-001 SELF-GROUNDING LUG KIT		
5	A50164-XXX 1.5" SQ. STL TUBE BRACE, L=XXX		
4	A21168-XXX PIPE, HSS, 2.875" OD X 12 GAUGE, L=XXX		
3	A21165-XXX PIPE, HSS, 2.375" OD X 12 GAUGE, L=XXX (REAR)		
2	A21165-XXX PIPE, HSS, 2.375" OD X 12 GAUGE, L=XXX (FRONT)		
1	A20380-001 2.5" PIPE END CAP		
ITEM	PART NUMBER	DESCRIPTION	QTY

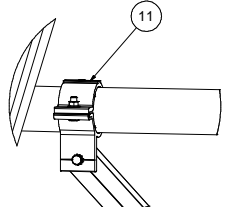
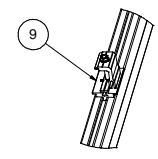
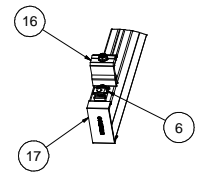
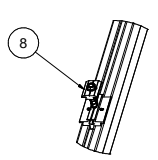
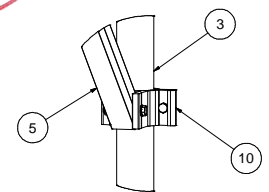
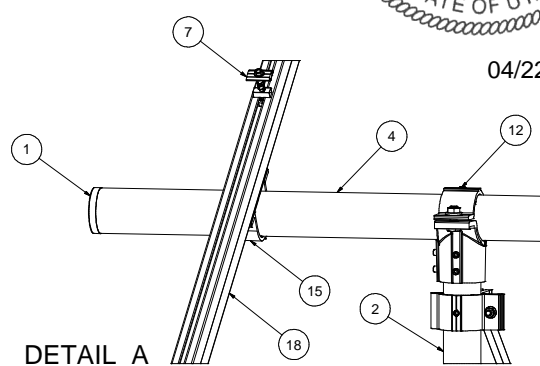

SEE BOM	
Third Angle Projection	
PERSONAL USE ONLY (NOT FOR REPRODUCTION)	
DATE: 04/21/2021	
CHECKED BY: KVV	

**SunModo Corp.**  
 14800 NE 65TH STREET, VANCOUVER WA 98662  
 TITLE: PACKET B3  
 DRAWING NUMBER: D  
 SCALE: SHEET 1 of 4

**NOTES:**

- 1. DIMENSIONS LABELED AS MAX ARE MAXIMUM ALLOWABLE AND MAY RESULT IN END POSTS BEING OUTSIDE ARRAY EDGES. MAXIMUM DIMENSIONS MAY BE REDUCED IF DESIRED.
- 2. SEE NOTE 7 OF COVER PAGE FOR PANEL SIZES.

**RAIL SPACING**

LANDSCAPE: PER PANEL MANUFACTURER  
PORTRAIT: PANEL WIDTH + 0.25"

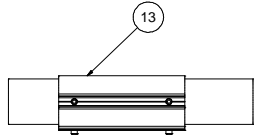

DETAIL G

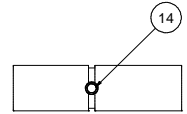
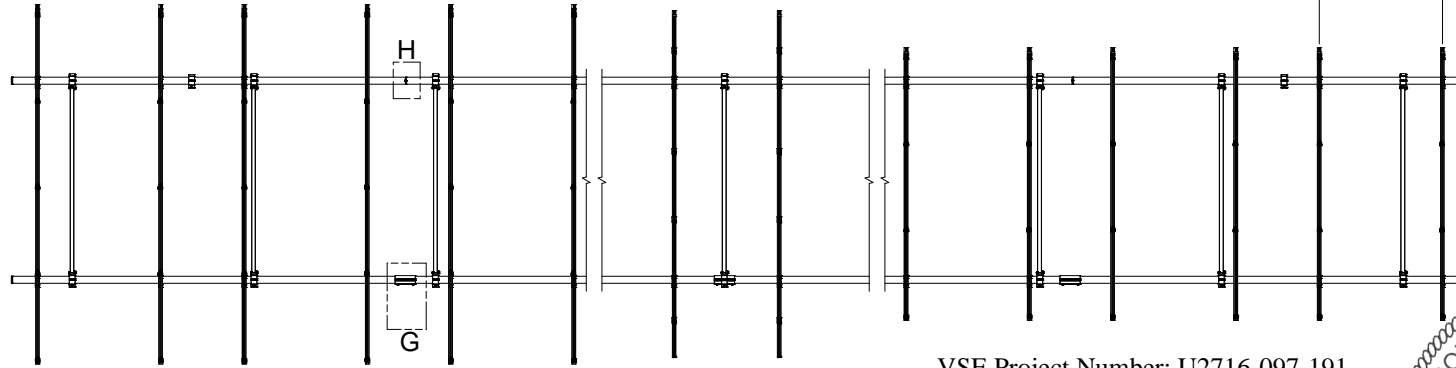

DETAIL H (ALTERNATE)

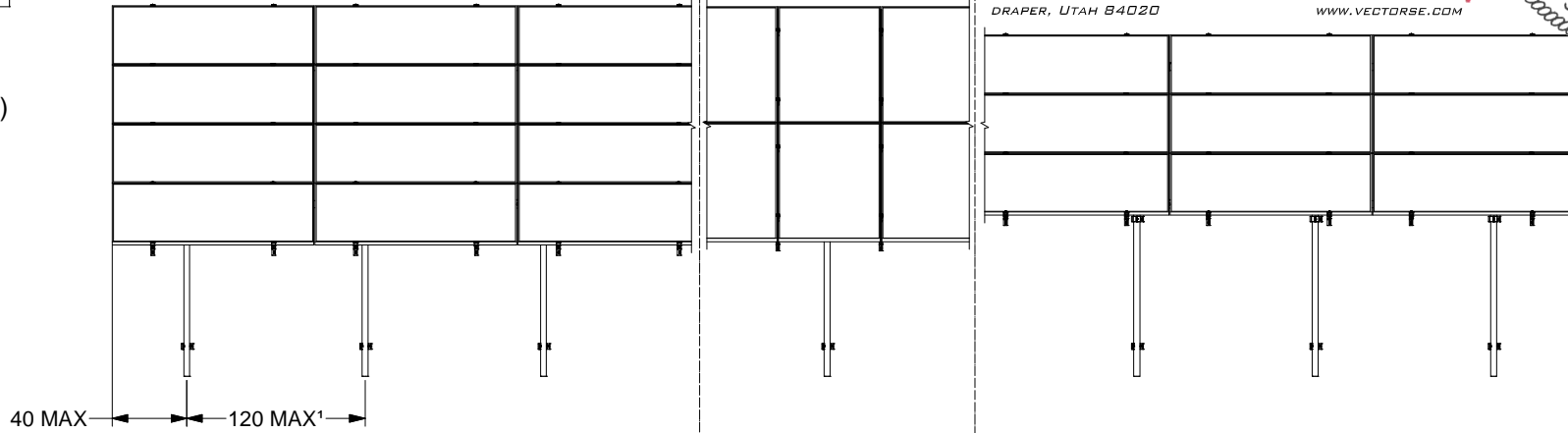

4L  
4-IN-LANDSCAPE

2P  
2-IN-PROTRAIT

3L  
3-IN-LANDSCAPE

VSE Project Number: U2716-097-191

STRUCTURAL ONLY



651 W. GALENA PARK BLVD, STE. 101 DRAPER, UTAH 84020 PHONE (801) 990-1775 WWW.VECTORSE.COM

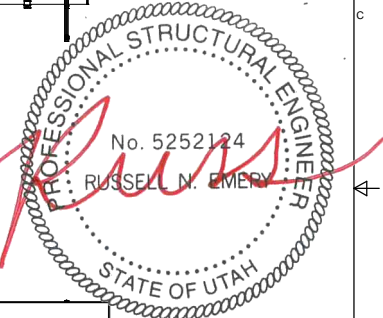

04/22/2021

<b>SunModo Corp.</b>	
TITLE	PACKET B3
D	DRAWING NUMBER
SCALE:	SHEET 2 of 4 REV

STRUCTURAL ONLY



651 W. GALENA PARK BLVD. STE. 101 DRAPER, UTAH 84020 PHONE (801) 990-1775 WWW.VECTORSE.COM

DIMENSIONS - STANDARD PANEL			
ITEM	4L	2P	3L
A	172	166	130
B	37	34	16
C	52	50	41
D	101	100	91

DIMENSIONS - OVERSIZE PANEL			
ITEM	4L	2P	3L
A	184	172	140
B	41	35	19
C	54	51	43
D	105	102	94

NOTES

1. DIMENSIONS IN TABLE ARE SHOWN AT MAXIMUM TILT & LEADING EDGE HEIGHT. PROJECTS WITH LOWER TILTS & LEADING EDGE HEIGHTS WILL RESULT IN REDUCED DIMENSIONS.
2. MAX DENOTES MAXIMUM PERMISSIBLE DIMENSIONS.
3. SEE NOTE 7 OF COVER PAGE FOR PANEL SIZES.

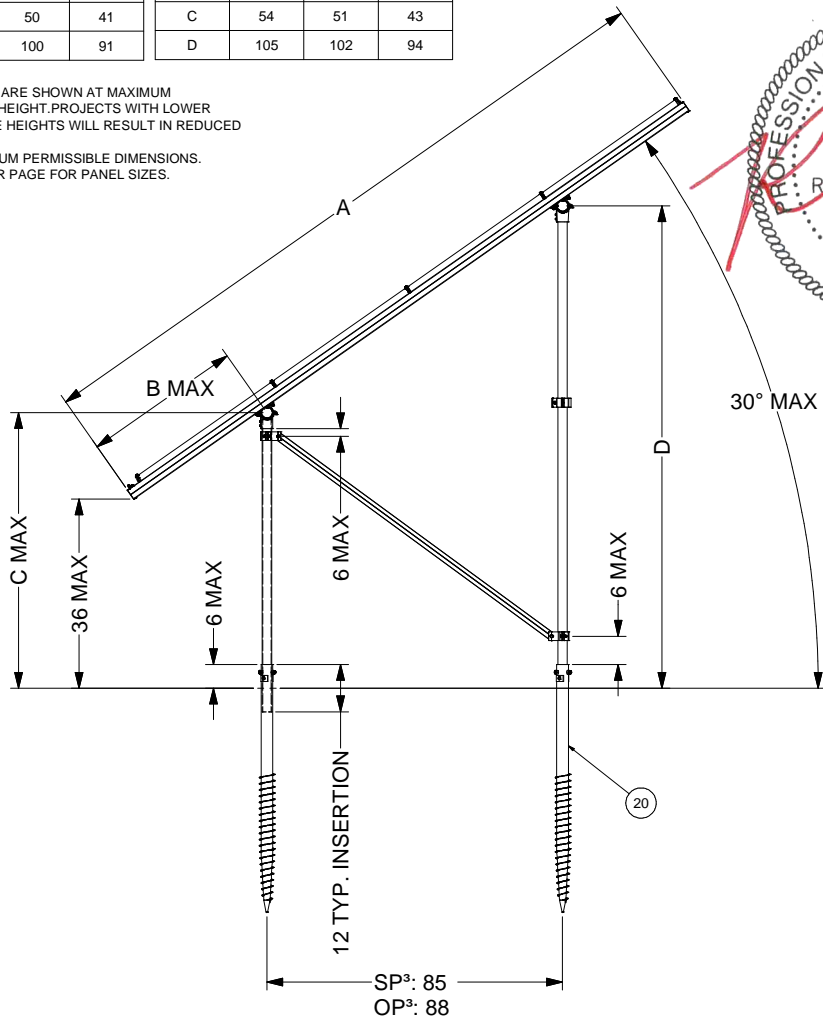
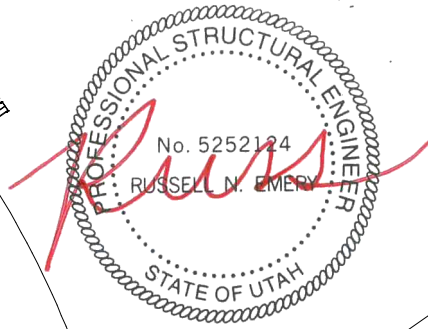

GROUND SCREW GROUND MOUNT (GSM)

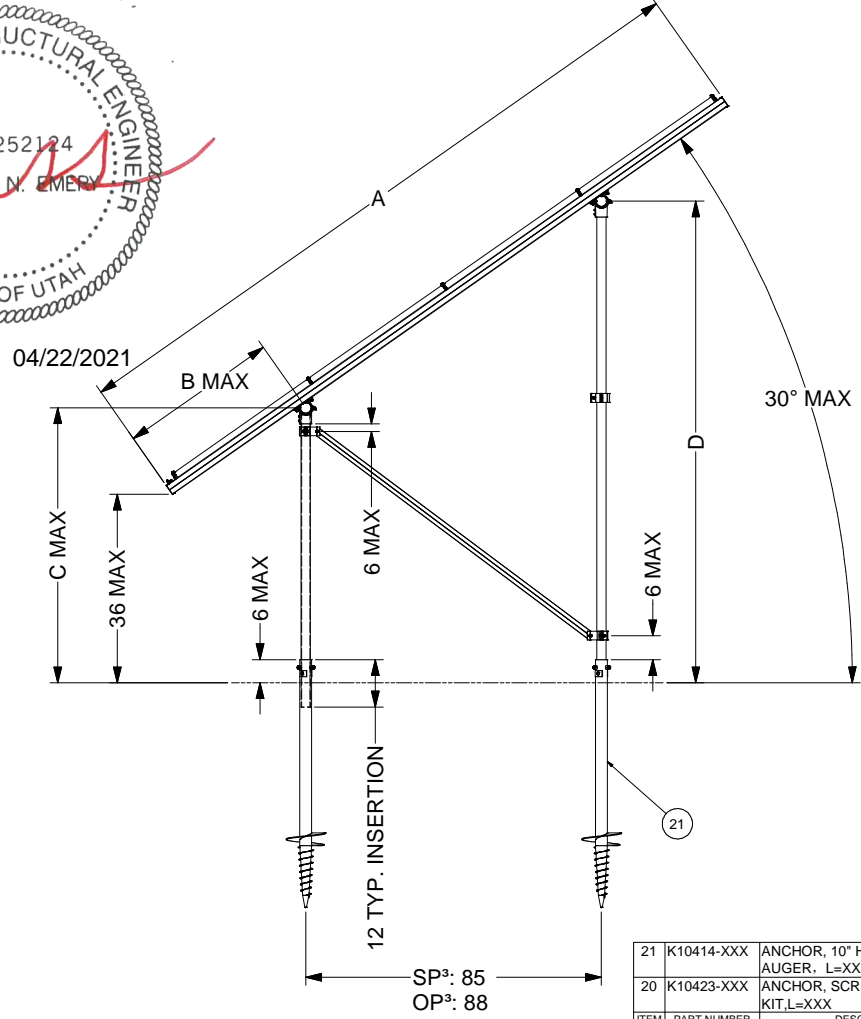

AUGER GROUND MOUNT (AGM)

21	K10414-XXX	ANCHOR, 10" HELIX SCREW AUGER, L=XXX	
20	K10423-XXX	ANCHOR, SCREW AUGER KIT, L=XXX	
ITEM	PART NUMBER	DESCRIPTION	QTY
<b>SunModo Corp.</b>			
TITLE: PACKET B3			
DRAWING NUMBER: D			
SCALE:		SHEET 3 of 4	REV

STRUCTURAL ONLY



651 W. GALENA PARK BLVD. STE. 101 DRAPER, UTAH 84020 PHONE (801) 990-1775 WWW.VECTORSE.COM

DIMENSIONS - STANDARD PANEL			
ITEM	4L	2P	3L
A	172	166	130
B	37	34	16
C	52	50	41
D	101	100	91

DIMENSIONS - OVERSIZE PANEL			
ITEM	4L	2P	3L
A	184	172	140
B	41	35	19
C	54	51	43
D	105	102	94

- NOTES**
1. DIMENSIONS IN TABLE ARE SHOWN AT MAXIMUM TILT & LEADING EDGE HEIGHT. PROJECTS WITH LOWER TILTS & LEADING EDGE HEIGHTS WILL RESULT IN REDUCED DIMENSIONS.
  2. MAX DENOTES MAXIMUM PERMISSIBLE DIMENSIONS.
  3. SEE NOTE 7 OF COVER PAGE FOR PANEL SIZES.
  4. K10268-005 (2" PIPE BASE KIT) OR K10302-001 (2" PIPE BASE KIT)

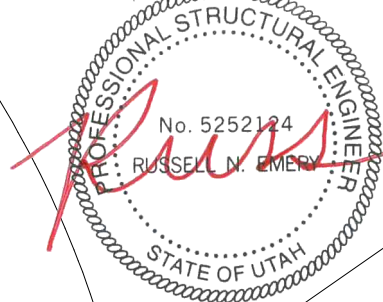

04/22/2021

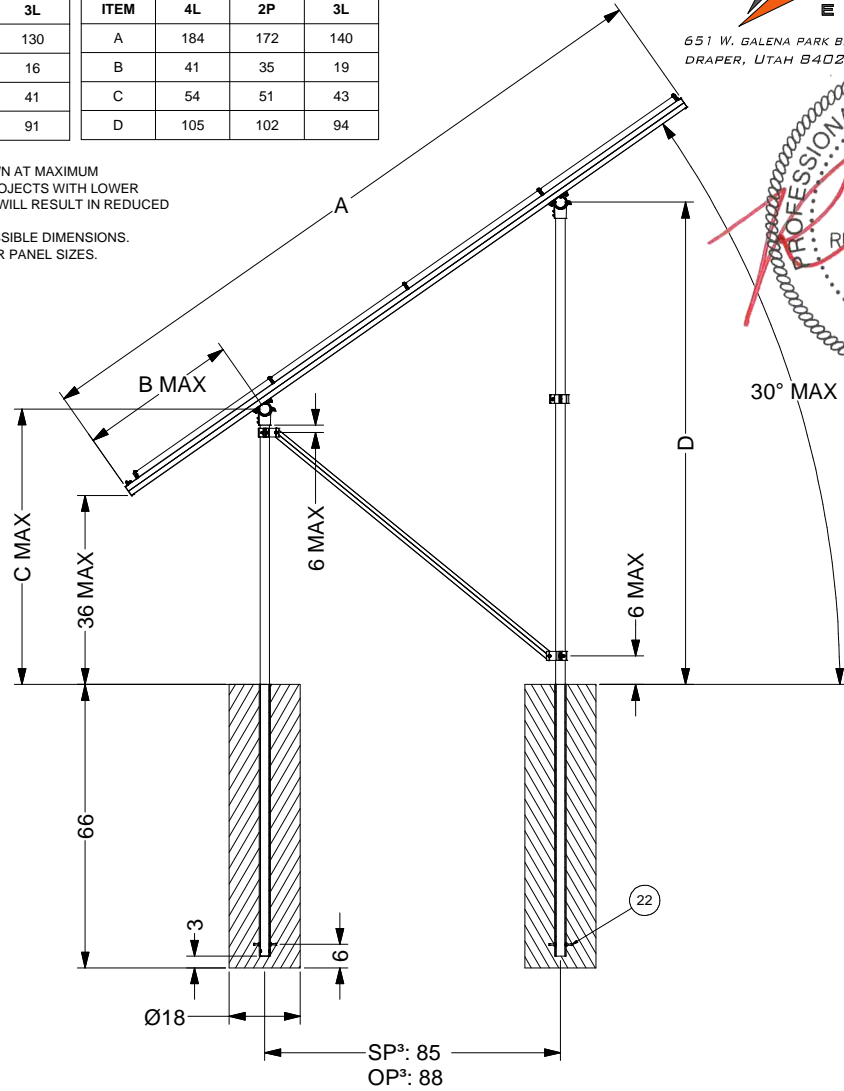

POST-IN-CONCRETE GROUND MOUNT (PGM)

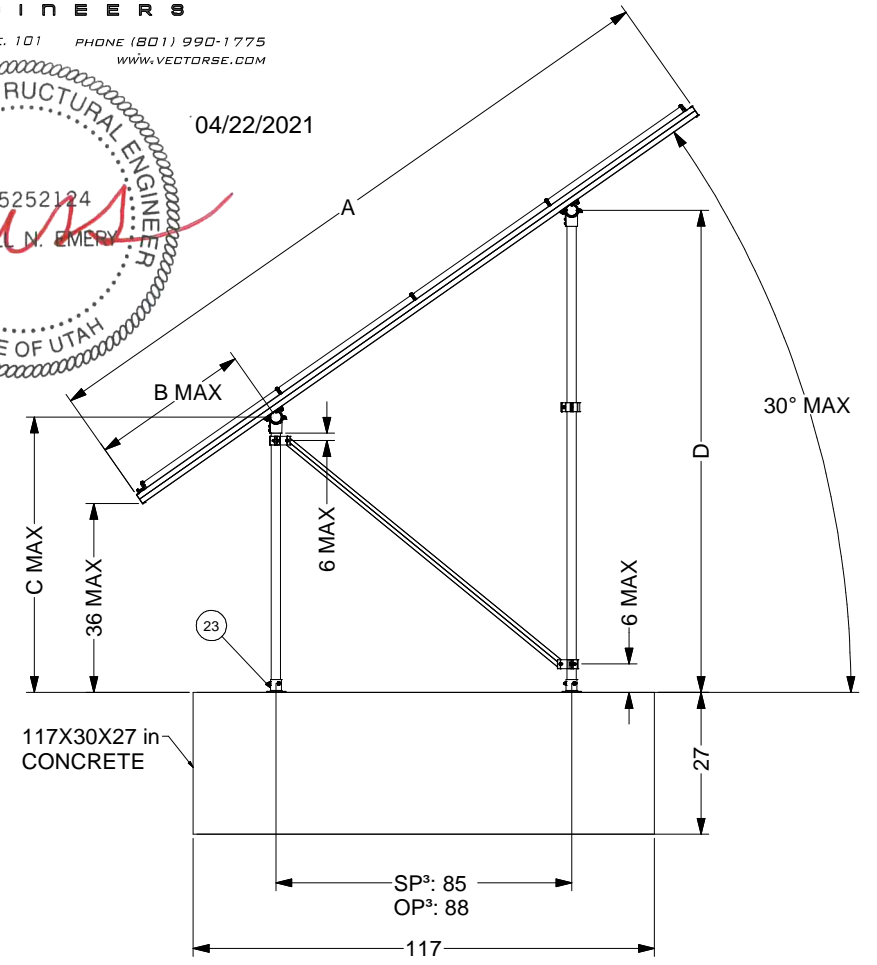

117X30X27 in CONCRETE

BALLAST GROUND MOUNT (BGM)

23		POST BASE. VARIES PER NOTE	
22	K10186-001	EMBEDDED 2.0" PIPE CLAMP KIT	
ITEM	PART NUMBER	DESCRIPTION	QTY
<b>SunModo Corp.</b>			
PACKET B3			
D			
SCALE: SHEET 4 of 4 REV			