



Project Number: U2716-0231-201

April 22, 2021

Sunmodo
14800 NE 65th Street
Vancouver, WA 98682

**REFERENCE: Sunmodo Sunturf Ground Mount A5a
Ground Mount PV Array Installation**

To Whom It May Concern:

Per request of Sunmodo, we have been asked to prepare the structural design of a ground-mounted PV solar array system with several foundation options as shown in the attached calculations. The adopted building code in this jurisdiction is the 2019 Oregon Structural Specialty Code (2018 IBC). Vector Structural Engineering requires that we review each site specific install, and we are not liable for installs at site specific locations we have not reviewed. The following design parameters are used in our analysis:

- Minimum Design Loads for Buildings and Other Structures (ASCE 7-16)
- Design wind speed for risk category I structures: 140 mph
- Wind exposure: B
- Ground snow load: 70 psf
- The ground screws and helical piers must be tested to 1.5 times uplift and 2.0 times lateral reactions found in the table below. A minimum of one ground screw or helical pier must be tested.

Load (ASD)	Value (lbs)	Factor of Safety	Test Value (lbs)
UPLIFT	2711	1.5	4067
LATERAL	1908	2	3816

Foundation concrete shall have a minimum compressive strength of 2500 psi at 28 days. Cement for all concrete shall be Type I or II with a minimum of 6% entrained air with a water/cement ratio of 0.50. Maximum aggregate size shall be 3/4". No special inspection of concrete strength is required.

Footings are designed based on an allowable soil bearing pressure of 1500 psf an allowable skin friction of 250 psf, an allowable lateral bearing pressure of 150 pcf, and a coefficient of friction of 0.3. Vector Structural Engineering strongly recommends independent soils testing be performed by a licensed geotechnical engineer to verify the assumed soil parameters.

All ground mounts are to be installed per manufacturer’s recommendations. The use of solar panel support span tables provided by the manufacturer is allowed only where the site conditions and solar panel configuration match the description of the span tables. Electrical engineering is beyond our scope. All work performed must be in accordance with accepted industry-wide methods and applicable safety standards. Vector Structural Engineering assumes no responsibility for improper installation of the solar panels.

Very truly yours,
VECTOR STRUCTURAL ENGINEERING, LLC

Wells Holmes, S.E.
License: 93806PE - Expires: 06/30/2021
Project Engineer

Enclosures

WLH/stb



04/02/2021

EXPIRES: 6/30/2021



JOB NO. U2716-0231-201
 PROJECT SUNMODO SUNTURF GROUND MOUNTS A5a
 SUBJECT ALL OPTIONS

651 W GALENA PARK BLVD. #101 (801) 990-1775
 DRAPER, UTAH 84020 (801) 990-1776 FAX

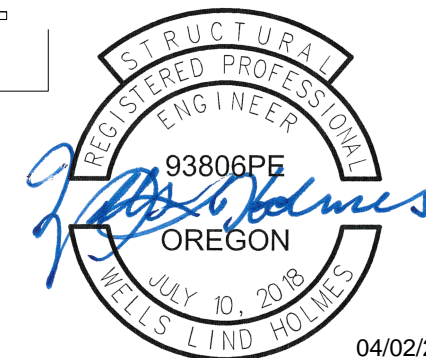
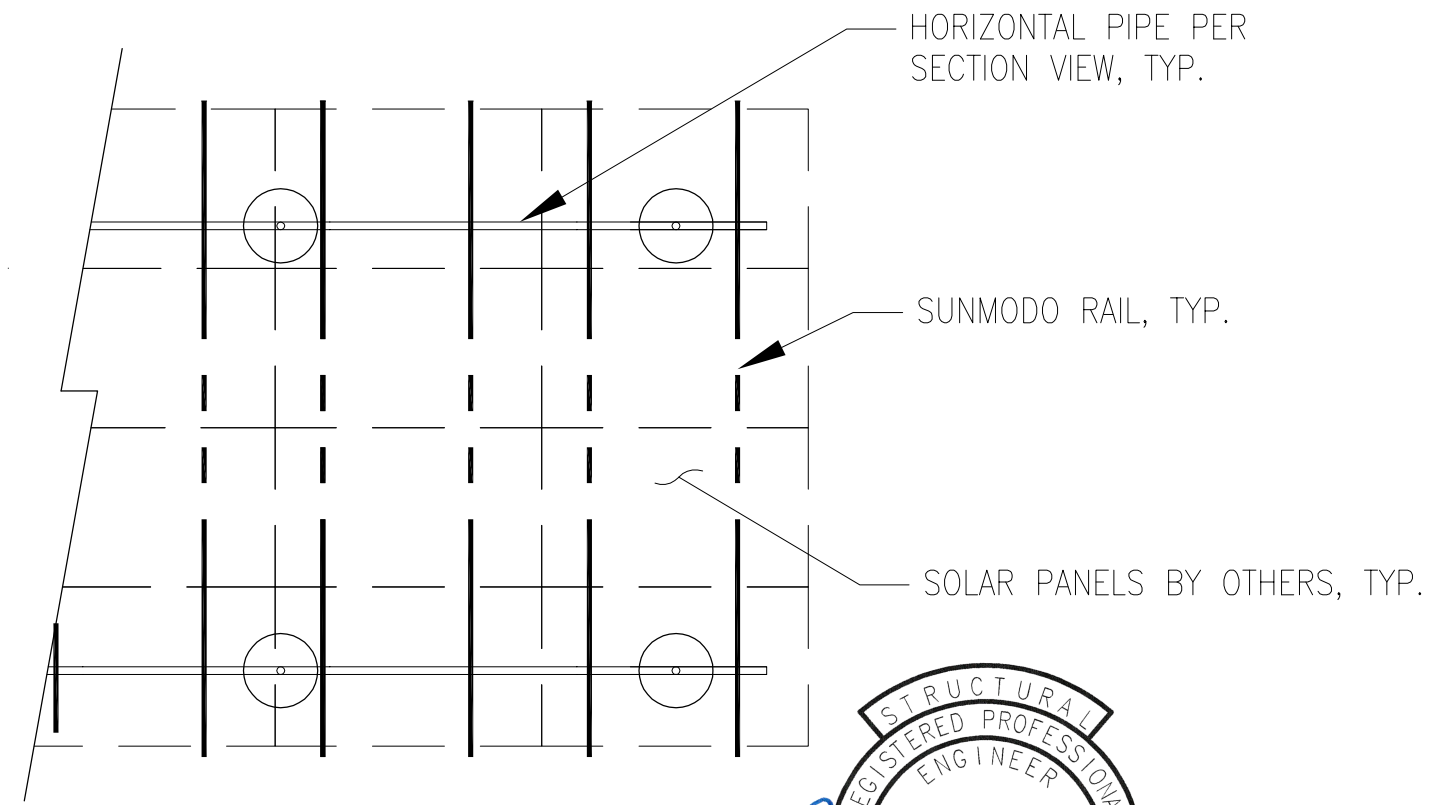
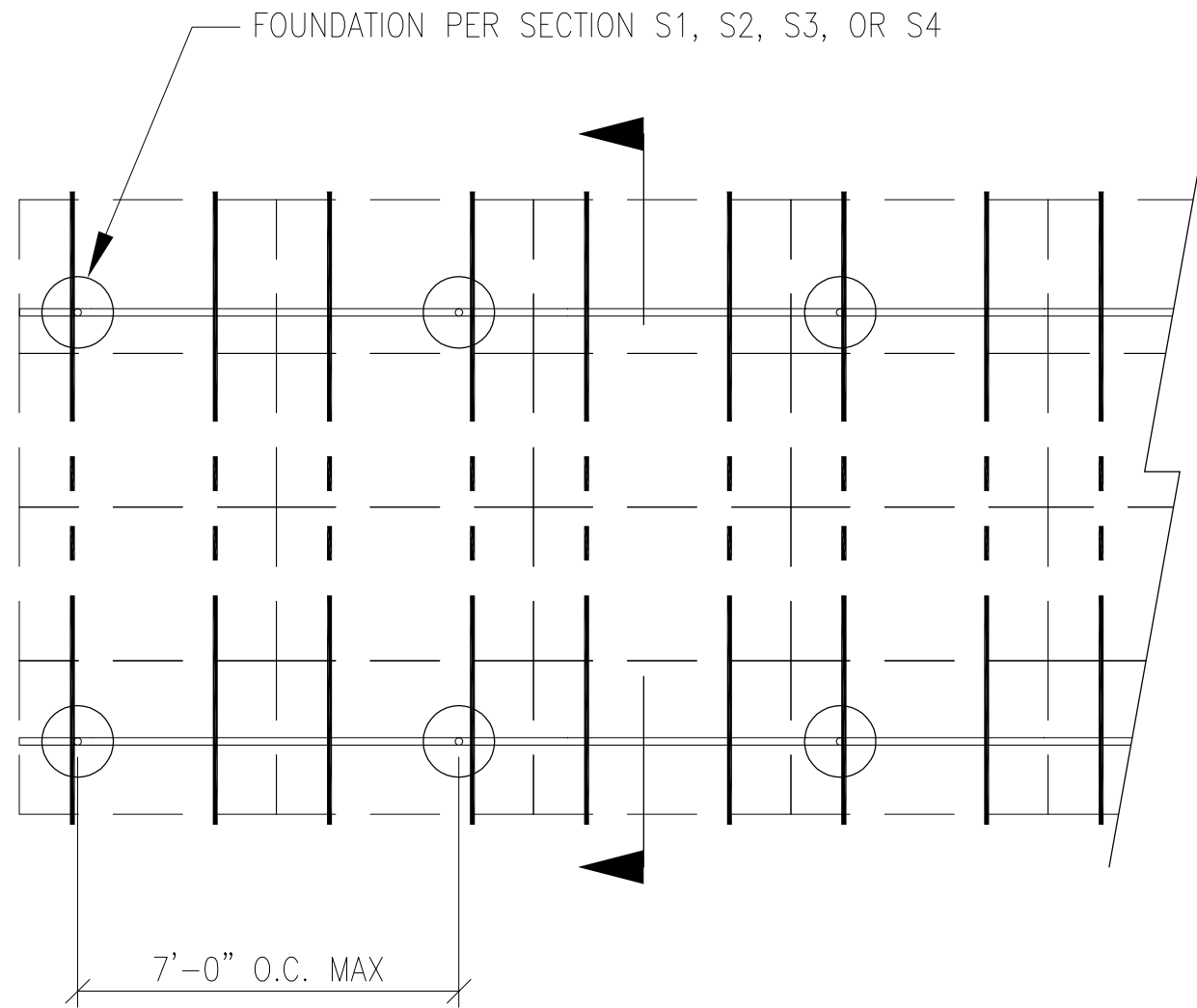

04/02/2021

EXPIRES: 6/30/2021

PV ARRAY PLAN

N.T.S.

P1

PROJECT SUNMODO SUNTURF GROUND MOUNTS A5a

SUBJECT DRILLED PIER OPTION

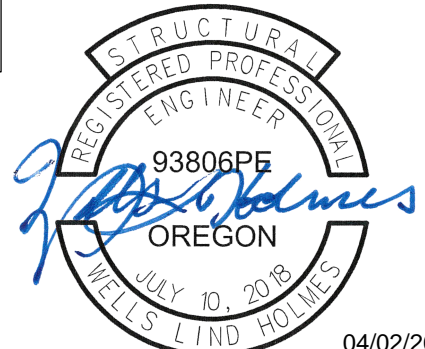
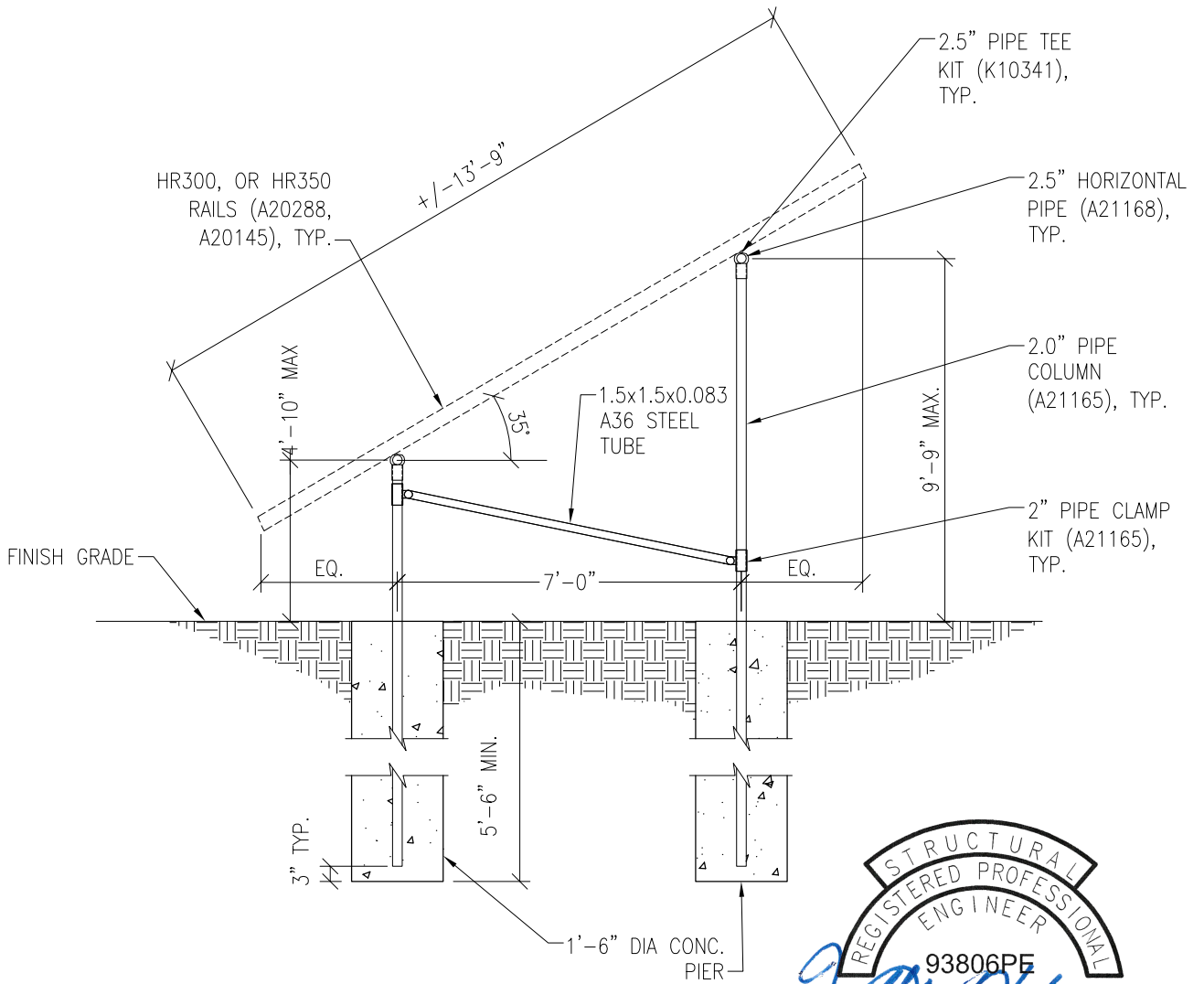

04/02/2021

EXPIRES: 6/30/2021

Vector Engineers requires that we review each site specific install and is not liable for installs at site specific locations we have not reviewed.

PV ARRAY SECTION

N.T.S.

S1

PROJECT SUNMODO SUNTURF GROUND MOUNTS A5a

SUBJECT HELICAL PIER OPTION

NOTES:

1. For ground mount components see Section S1.
2. A minimum of (1) helical pier must be load-tested as follows:
 - 2.1. Safety factor for uplift = 1.5,
 - 2.2. Safety factor for lateral loads = 2.0
 - 2.3. Upward deflection limit = 1/2"
 - 2.4. Lateral deflection limit = 1"
 - 2.5. The load tests must be performed by an approved contractor.

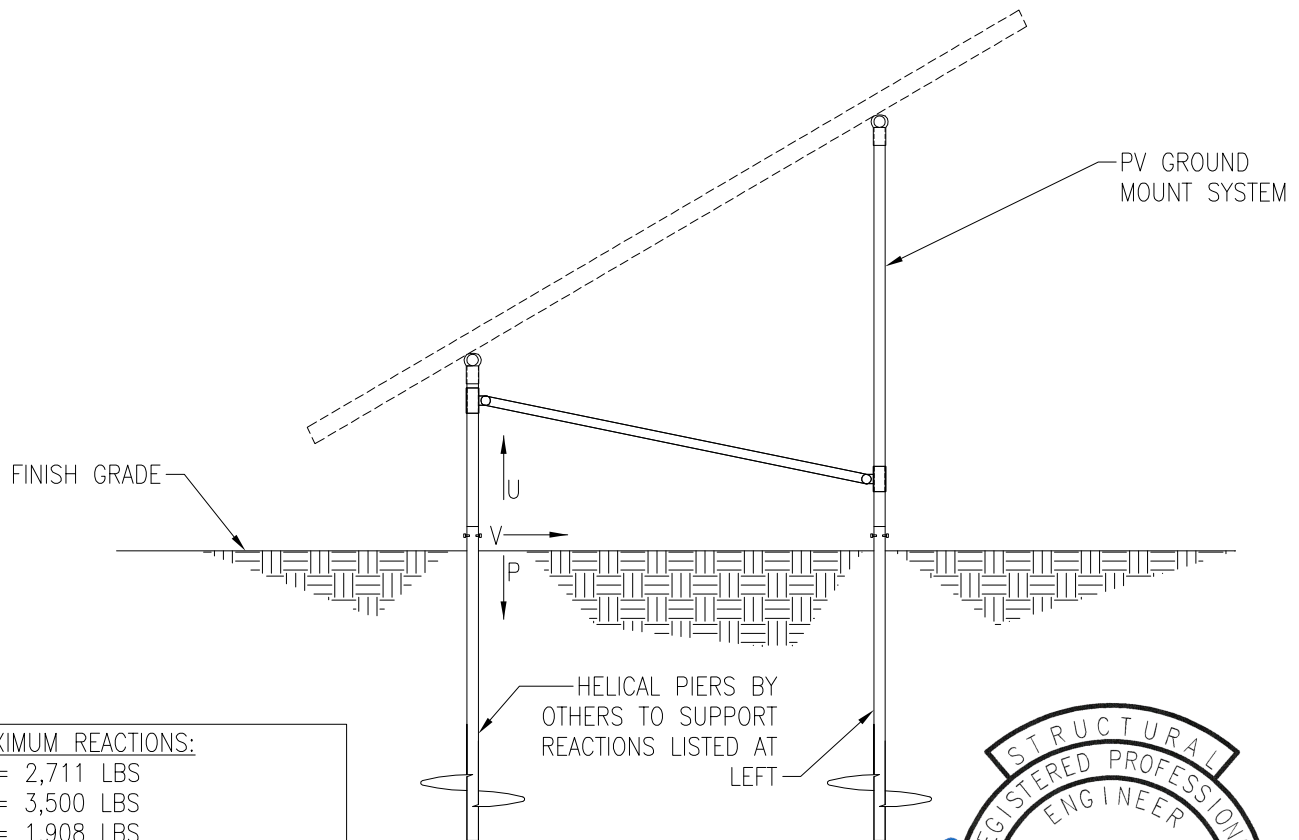

MAXIMUM REACTIONS:
 U = 2,711 LBS
 P = 3,500 LBS
 V = 1,908 LBS

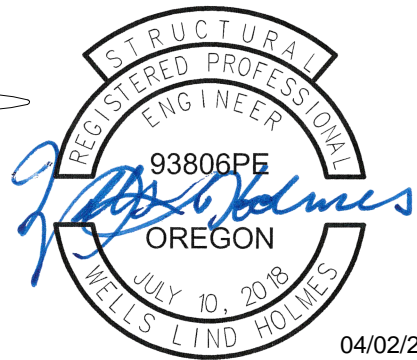

04/02/2021

EXPIRES: 6/30/2021

Vector Engineers requires that we review each site specific install and is not liable for installs at site specific locations we have not reviewed.

PV ARRAY SECTION

N.T.S.

S2

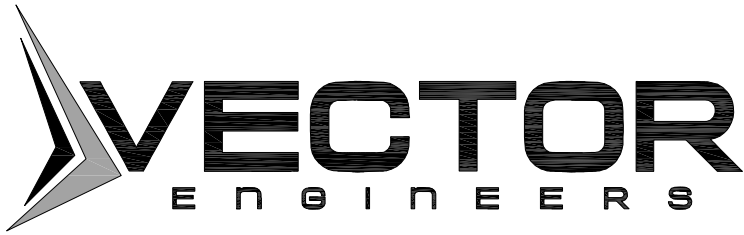

JOB NO. U2716-0231-201

PROJECT SUNMODO SUNTURF GROUND MOUNTS A5a

SUBJECT GROUND SCREW OPTION

NOTES:

- 1. For ground mount components see Section S1.
- 2. A minimum of (1) ground screw must be load-tested as follows:
 - 2.1. Safety factor for uplift = 1.5,
 - 2.2. Safety factor for lateral loads = 2.0
 - 2.3. Upward deflection limit = 1/2"
 - 2.4. Lateral deflection limit = 1"
 - 2.5. The load tests must be performed by an approved contractor.

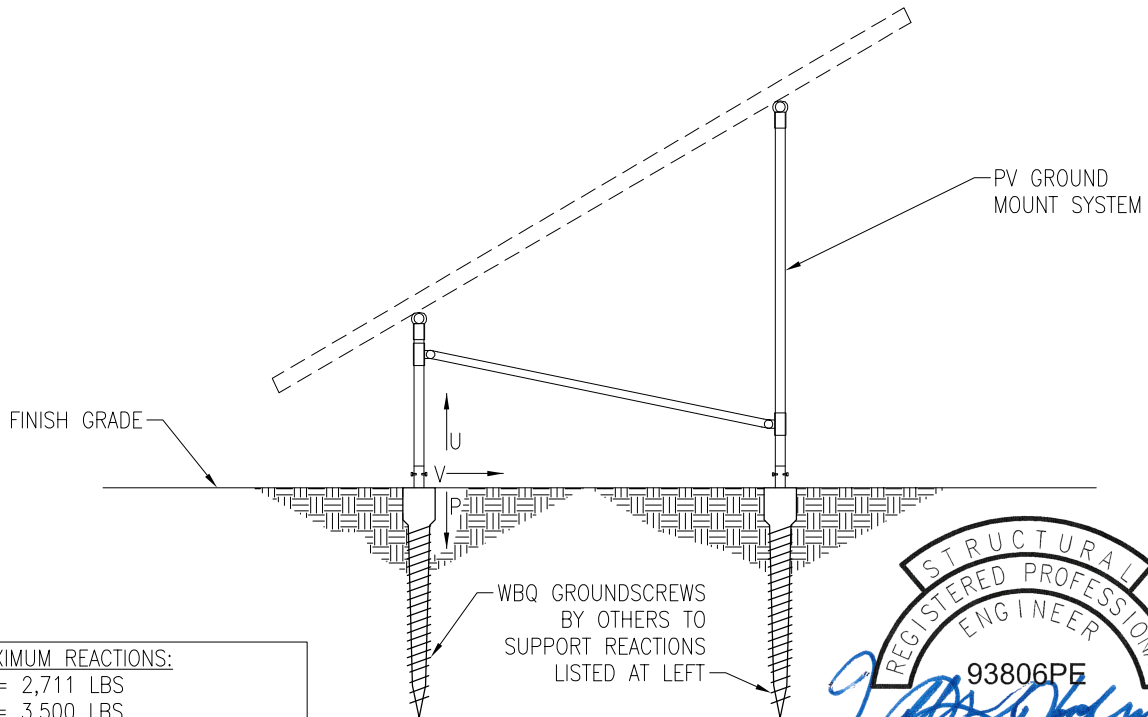

MAXIMUM REACTIONS:
 U = 2,711 LBS
 P = 3,500 LBS
 V = 1,908 LBS

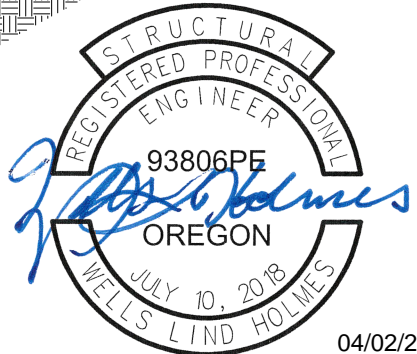

Vector Engineers requires that we review each site specific install and is not liable for installs at site specific locations we have not reviewed.

04/02/2021

PV ARRAY SECTION EXPIRES: 6/30/2021

N.T.S.



651 W GALENA PARK BLVD. #101
 DRAPER, UTAH 84020

(801) 990-1775
 (801) 990-1776 FAX

WWW.VECTORSE.COM



JOB NO. U2716-0231-201

PROJECT SUNMOD0 SUNTURF GROUND MOUNTS A5a

SUBJECT BALLASTED BLOCK OPTION

NOTES:

1. For ground mount components see Section S1.

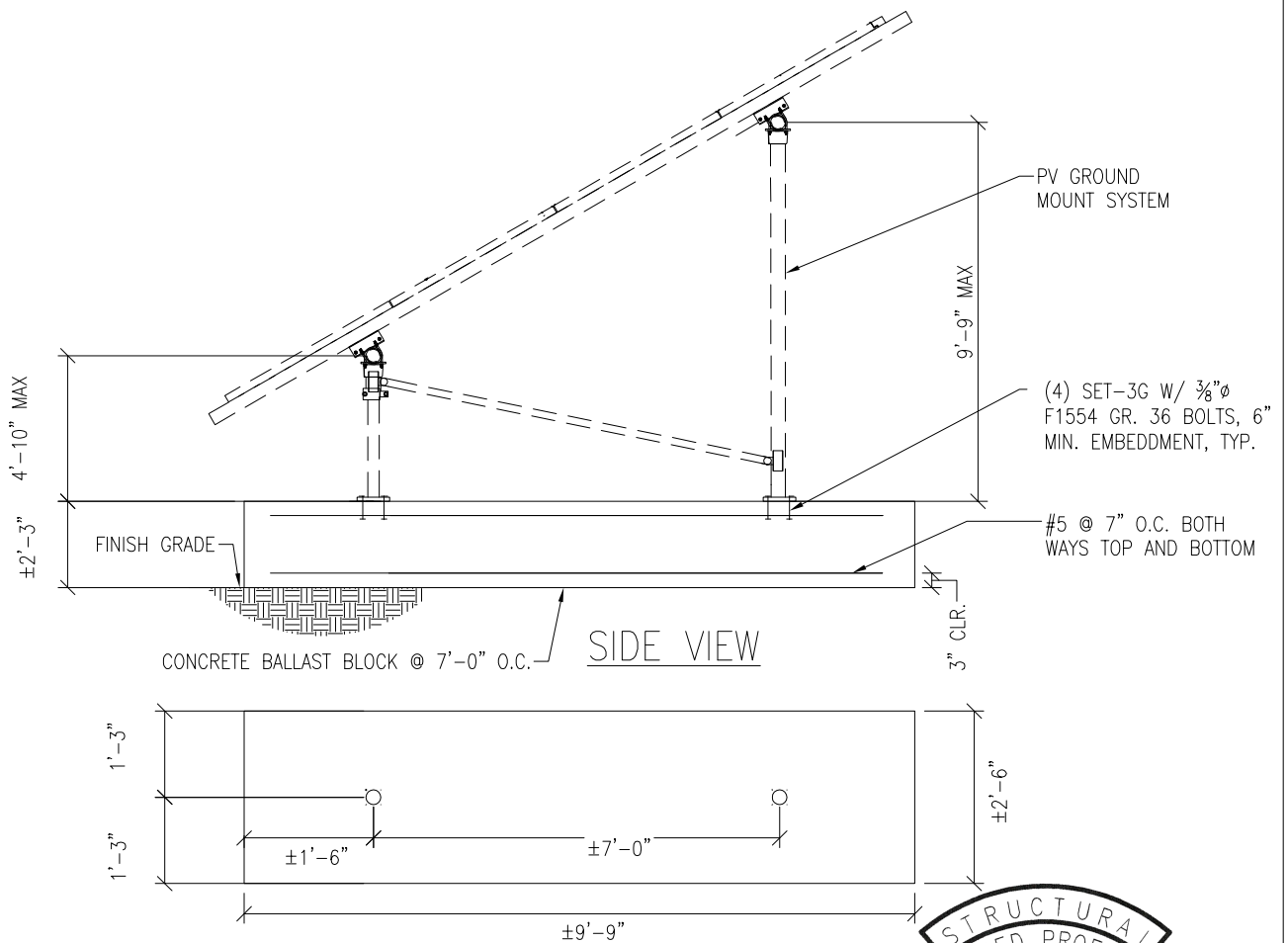

Vector Engineers requires that we review each site specific install and is not liable for installs at site specific locations we have not reviewed.

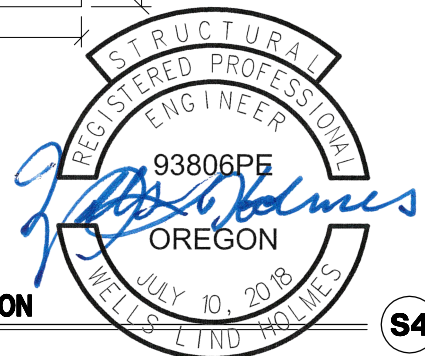

PV ARRAY SECTION

N.T.S.

S4

651 W GALENA PARK BLVD. #101
 DRAPER, UTAH 84020

(801) 990-1775
 (801) 990-1776 FAX

EXPIRES: 6/30/2021

WWW.VECTORSE.COM

04/02/2021



PROJECT: Sunturf Package A5A Ground Mount

SNOW LOADS

Calculations Per:	ASCE 7-16	
Snow Ground Load, p_g [psf]:	70.0	(Section 7.2)
Risk Category:	I	(Table 1.5-1)
Importance Factor, I_s :	0.8	(Table 1.5-2)
Terrain Category:	B	(Section 26.7)
Exposure of Roof:	Fully Exposed	(Table 7-3.1)
Exposure Factor, C_e :	0.9	(Table 7-3.1)
Thermal Factor, C_t :	1.2	(Table 7-3.2)
Flat Roof Snow Load, p_f [psf]:	42	(Equation 7.3-1)
Min. Roof Snow Load, p_m [psf]:	0	(Section 7.3.4)
Panel Slope from Horizontal [°]:	35.0	
Unobstructed Slippery Surface?	Yes	(Section 7.4)
Slope Factor Figure:	Figure 7-2c	(of Figure 7.4-1 - See Section 7.4)
Roof Slope Factor, C_s :	0.64	
Sloped Roof Snow Load, p_s [psf]:	27	(Equation 7.4-1)
Design Snow Load, S [psf]:	27	(1.0 Snow)



PROJECT: Sunturf Package A5A Ground Mount

WIND PRESSURES

Calculations per:	ASCE 7-16	
Design Wind Speed, V [mph]:	140	
Risk Category:	I	(Table 1.5-1)
Exposure Category:	B	(Section 26.7)
Ground Elevation Factor, K_e :	1.0	(Table 26.9-1)
α :	7.0	(Table 26.11-1)
z_g [ft]:	1200	(Table 26.11-1)
Velocity Pressure Exposure Coefficient, K_h :	0.57	(Table 26.10-1)
Topographic Factor, K_{ht} :	1.00	(Section 26.8)
Wind Directionality Factor, K_d :	0.85	(Table 26.6-1)
Internal Pressure Coefficient, GC_{pi} :	0.0	(Figure 26.13-1)
Velocity Pressure, q_h [psf]:	24.31	(Equation 26.10-1)
Gust Effect Factor, G:	0.85	(Section 26.11.4)
Panel Slope [degrees]:	35.0	
Wind Flow:	Clear	
Roof Configuration:	Monoslope	

Wind Pressures in Transverse (N-S) Direction

Net Pressure Coefficients per Figure 27.3-4

Clear Wind Flow	C_{NW}	C_{NL}
Case 1 ($\gamma = 0^\circ$, Load Case A)	-1.8	-1.8
Case 2 ($\gamma = 0^\circ$, Load Case B)	-2.4	-0.6
Case 3 ($\gamma = 180^\circ$, Load Case A)	2.1	2.1
Case 4 ($\gamma = 180^\circ$, Load Case B)	2.7	1.1

Design Wind Pressures per Equation 27.3-2 [psf]

Clear Wind Flow	$q_h GC_{NW}$	$q_h GC_{NL}$
Case 1 ($\gamma = 0^\circ$, Load Case A)	-37.2	-37.2
Case 2 ($\gamma = 0^\circ$, Load Case B)	-49.6	-12.4
Case 3 ($\gamma = 180^\circ$, Load Case A)	43.4	43.4
Case 4 ($\gamma = 180^\circ$, Load Case B)	55.8	22.7
Case 5 ($\gamma = 0^\circ$, 16 psf Min. Horiz.)	-16.0	-16.0
Case 6 ($\gamma = 180^\circ$, 16 psf Min. Horiz.)	16.0	16.0

Wind Pressures in Longitudinal (E-W) Direction



PROJECT: Sunturf Package A5A Ground Mount

WIND PRESSURES

Net Pressure Coefficients per Figure 27.3-7

Clear Wind Flow	C_N
Case 1 ($\gamma = 90^\circ$, $d < h$, Load Case A)	-0.80
Case 2 ($\gamma = 90^\circ$, $h < d < 2h$, Load Case A)	-0.60
Case 3 ($\gamma = 90^\circ$, $d > 2h$, Load Case A)	-0.30
Case 4 ($\gamma = 90^\circ$, $d < h$, Load Case B)	0.80
Case 5 ($\gamma = 90^\circ$, $h < d < 2h$, Load Case B)	0.50
Case 6 ($\gamma = 90^\circ$, $d > 2h$, Load Case B)	0.30

Design Wind Pressures per Equation 27.3-2 [psf]

Clear Wind Flow	$q_h GC_N$
Case 1 ($\gamma = 90^\circ$, $d < h$, Load Case A)	-16.5
Case 2 ($\gamma = 90^\circ$, $h < d < 2h$, Load Case A)	-12.4
Case 3 ($\gamma = 90^\circ$, $d > 2h$, Load Case A)	-6.2
Case 4 ($\gamma = 90^\circ$, $d < h$, Load Case B)	16.5
Case 5 ($\gamma = 90^\circ$, $h < d < 2h$, Load Case B)	10.3
Case 6 ($\gamma = 90^\circ$, $d > 2h$, Load Case B)	6.2

Notation:

h = mean roof height, ft

d = horizontal distance from windward edge



JOB NO.: U2716-0231-201

DESIGNED: STB

Foundation Option 1: Drilled Concrete Pier



PROJECT: Sunturf Package A5A Ground Mount

DRILLED CONCRETE PIER DESIGN

Column Reactions:

Max. Shear, V [k]:	1.9	Max. Down, P _d [k]:	3.5
Max. Moment, M [k-ft]:	0.0	Max. Uplift, P _u [k]:	2.7

Pier Properties:

Pier Shape:	Round	Volume of Concrete [ft ³]:	10
Pier Diameter, b [ft]:	1.5	Volume of Concrete [yd ³]:	0.4
Top of Pier Elevation [ft]:	0.00	Weight of Concrete [k]:	1.5
Pier Depth, d [ft]:	5.5		

Soil Properties:

Allow. Bearing Pressure [psf]:	1,500	<u>Optional Parameters for Uplift:</u>	
1/3 increase for short term loads?	No		
Lateral Bearing, S [pcf]:	150	Skin Friction* [psf]:	250
Max. Lateral Bearing (opt'l) [psf]:		Top Length to Ignore [ft]:	0
Top Depth to Ignore [ft]:	0	1/3 increase for short term loads?	No
1/3 increase for short term loads?	No	Combine w/ Bearing:	No
1/2" deflection at t/o pier allowed:	Yes		

*per IBC Section 1810.3.3.1.4

Check Bearing:

Bearing Capacity [k]:	6.5
-----------------------	-----

Bearing capacity OK.

Check Uplift:

Uplift Capacity [k]:	7.8
----------------------	-----

Uplift capacity OK.

Check Lateral Bearing:

Top of Pier Constrained?:	No	IBC Section 1807.3.2.1
Applied Lateral Force, P [lb]:	1,908	
Point of Application, h [ft]:	0.0	
S _{max} [psf]:		
S [psf]:	550	
A = 2.34*P/(S _b):	5.41	
Required Pier Depth, d _{reqd} [ft]:	5.40	IBC Eq. 18-1

Result: **Lateral bearing capacity OK.**

Foundation Option 2: Helical Pier

The ground screws and helical piers must be tested to 1.5 times uplift and 2.0 times lateral reactions found in the table below.

Load (ASD)	Value (lbs)	Factor of Safety	Test Value (lbs)
UPLIFT	2711	1.5	4067
LATERAL	1908	2	3816

Foundation Option 3: Ground Screw

The ground screws and helical piers must be tested to 1.5 times uplift and 2.0 times lateral reactions found in the table below.

Load (ASD)	Value (lbs)	Factor of Safety	Test Value (lbs)
UPLIFT	2711	1.5	4067
LATERAL	1908	2	3816



JOB NO.: U2716-0231-201

DESIGNED: STB

Foundation Option 4: Ballasted Block

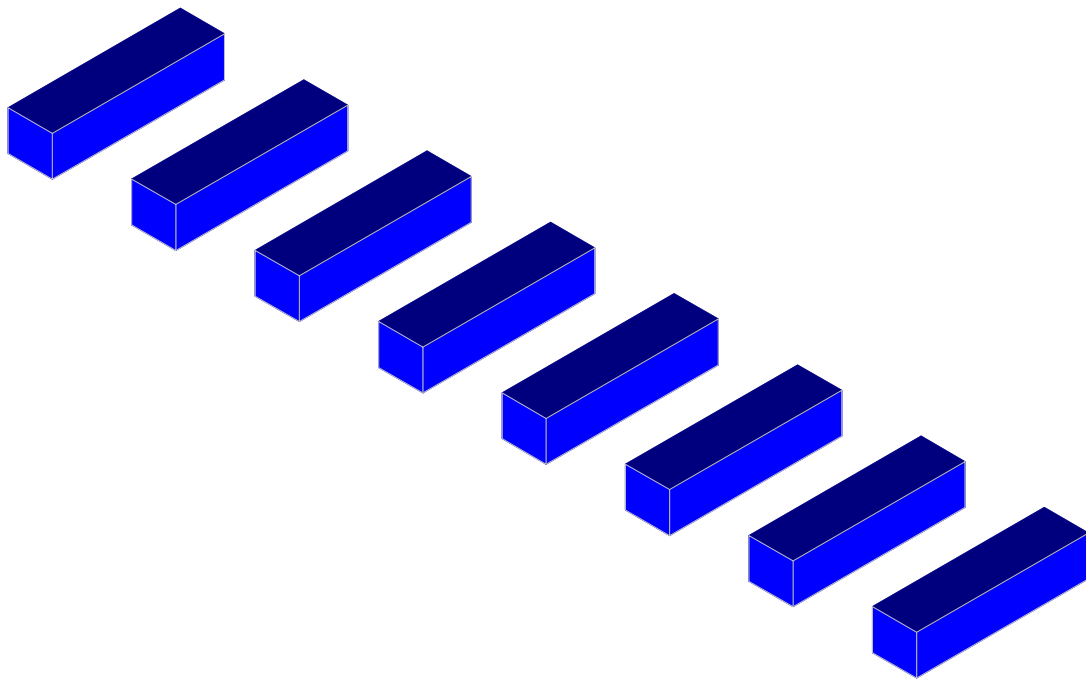

Results for LC 1, 1.0 D

Vector Structural Engineeri..	Ground Mount	SK - 2
STB		Apr 2, 2021 at 4:57 PM
U2716.0231.201		Sunmodo Sunturf A5a v3 85x45.r3d

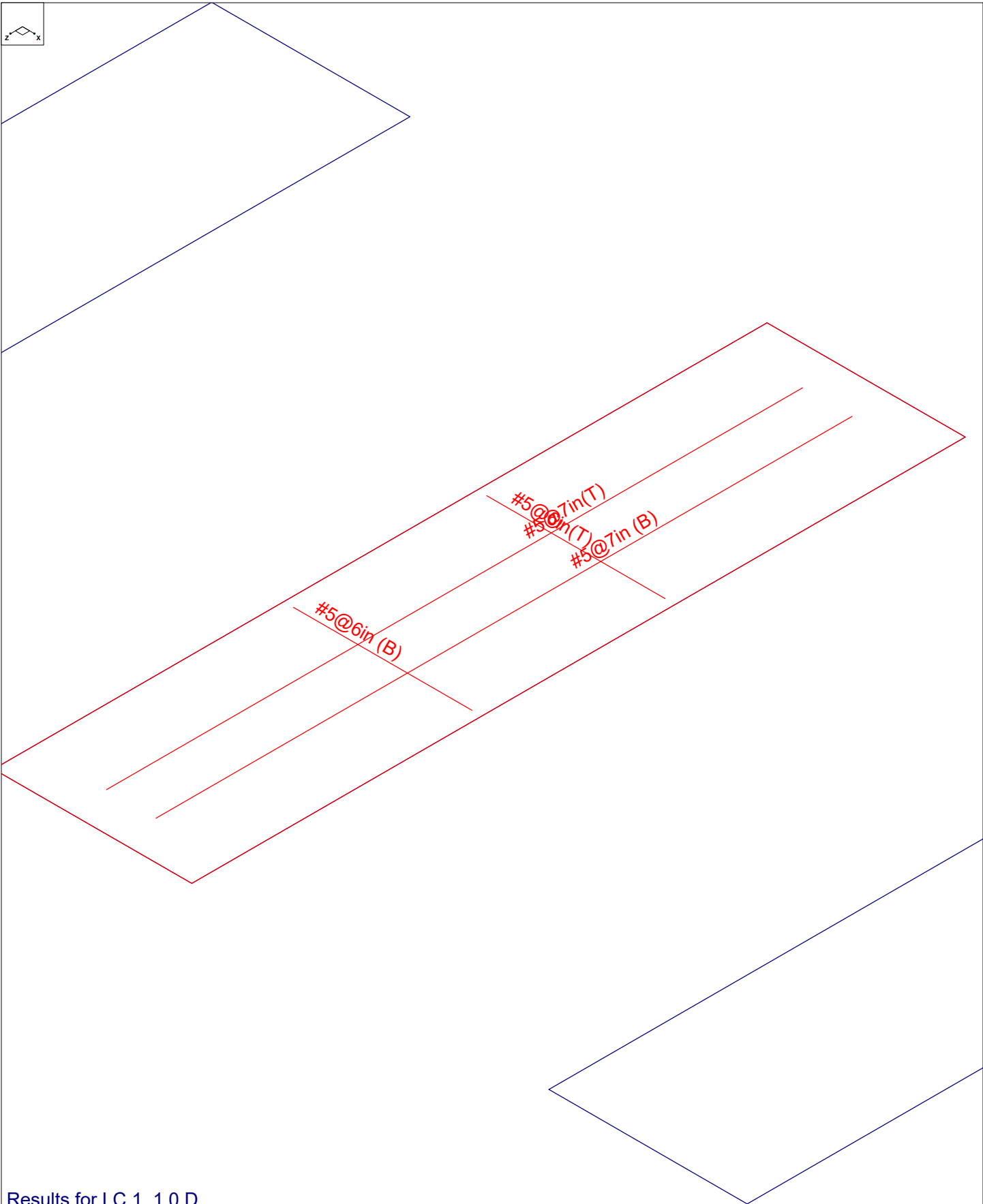

Results for LC 1, 1.0 D

Vector Structural Engineeri..	Ground Mount	SK - 1
STB		Apr 2, 2021 at 4:57 PM
U2716.0231.201		Sunmodo Sunturf A5a v3 85x45.r3d



(Global) Model Settings

Display Sections for Member Calcs	5
Max Internal Sections for Member Calcs	100
Mesh Size (in)	12
Max Iterations	10
Merge Tolerance (in)	.12
Solver	Sparse Accelerated
Coefficient of Friction	.3
No. of Shear Regions	4
Shear Region Spacing Increment (in)	4
Min 1 Bar Dia Spacing for Beams?	No
Optimize footings for OTM / Sliding?	Yes
Parme Beta Factor	.65
Pile Safety Factor	3
Concrete Stress Block	0
Concrete Rebar Set	Rectangular
Concrete Code	ASTM A615
HR Steel Pile Code	ACI 318-14
Wood Pile Code	AISC 14th (360-10): ASD AWC NDS-15: ASD

Concrete Properties

	Label	E [ksi]	G [ksi]	Nu	Therm (/...	Density[lb/ft^3]	fc[psi]	Lambda	Flex Stee...	Shear St...
1	Conc3000NW	3156	1372	.15	.6	145	3000	1	60000	60000
2	Conc3500NW	3409	1482	.15	.6	145	3500	1	60000	60000
3	Conc4000NW	3644	1584	.15	.6	145	4000	1	60000	60000
4	Conc3000LW	2085	907	.15	.6	109.999	3000	.75	60000	60000
5	Conc3500LW	2252	979	.15	.6	109.999	3500	.75	60000	60000
6	Conc4000LW	2408	1047	.15	.6	109.999	4000	.75	60000	60000
7	Conc2500NW	3156	1372	.15	.6	145	2500	1	60000	60000

General Design Parameters

	Label	Max Bending Chk	Max Shear Chk	Top Cover[in]	Bottom Cover[in]
1	Typical	1	1	3	3

Slab Rebar Parameters

	Label	Top Bar	Bottom Bar	Max Top Bar Sp...	Min Top Bar Sp...	Max Bot Bar Sp...	Min Bot Bar Sp...	Spacing Incr...	Rebar Options
1	Typical	#5	#5	18	3	18	3	1	Optimize

Soil Definitions

	Label	Subgrade Modulus[lb/ft^3]	Allowable Bearing[psf]	Depth Properties	Default?
1	Default	1.72e+5	1500	None	Yes

Point Loads and Moments (Cat 1 : DL)

	Label	Direction	Magnitude[lb,lb-ft]
1	R3D_N1	X	-12.991
2	R3D_N1	Y	145.254
3	R3D_N2_1	X	-8.438
4	R3D_N2_1	Y	108.936
5	R3D_N132	Y	232.196
6	R3D_N133	Y	214.938
7	R3D_N109	Y	237.762
8	R3D_N110A	X	1.806

Point Loads and Moments (Cat 1 : DL) (Continued)

	Label	Direction	Magnitude[lb,lb-ft]
9	R3D_N110A	Y	231.733
10	R3D_N121	Y	230.328
11	R3D_N122	Y	211.611
12	R3D_N133B_1	Y	232.188
13	R3D_N134B	Y	214.942
14	R3D_N151	Y	230.302
15	R3D_N152	Y	211.619
16	R3D_N143A_1	X	13.004
17	R3D_N143A_1	Y	147.672
18	R3D_N144A_1	X	8.41
19	R3D_N144A_1	Y	111.322
20	R3D_N149A	Y	237.741
21	R3D_N150A	X	-1.798
22	R3D_N150A	Y	231.648

Point Loads and Moments (Cat 6 : RLL)

	Label	Direction	Magnitude[lb,lb-ft]
1	R3D_N1	X	-71.468
2	R3D_N1	Y	610.28
3	R3D_N2_1	X	-49.701
4	R3D_N2_1	Y	522.609
5	R3D_N132	Y	1182.121
6	R3D_N133	Y	1157.906
7	R3D_N109	X	1.652
8	R3D_N109	Y	1213.296
9	R3D_N109	Z	-1.115
10	R3D_N110A	X	10.87
11	R3D_N110A	Y	1261.756
12	R3D_N121	Y	1172.481
13	R3D_N122	X	-1.778
14	R3D_N122	Y	1137.549
15	R3D_N133B_1	Y	1182.058
16	R3D_N134B	Y	1157.932
17	R3D_N151	Y	1172.277
18	R3D_N152	X	1.834
19	R3D_N152	Y	1137.598
20	R3D_N143A_1	X	71.581
21	R3D_N143A_1	Y	624.719
22	R3D_N144A_1	X	49.559
23	R3D_N144A_1	Y	536.802
24	R3D_N149A	X	-1.713
25	R3D_N149A	Y	1213.129
26	R3D_N149A	Z	-1.223
27	R3D_N150A	X	-10.838
28	R3D_N150A	Y	1261.239

Point Loads and Moments (Cat 16 : OL1)

	Label	Direction	Magnitude[lb,lb-ft]
1	R3D_N1	X	129.05
2	R3D_N1	Y	-1882.199
3	R3D_N1	Z	1006.708
4	R3D_N2_1	X	37.715
5	R3D_N2_1	Y	286.967
6	R3D_N2_1	Z	-62.596
7	R3D_N132	Y	-4016.685
8	R3D_N132	Z	2370.449

Point Loads and Moments (Cat 16 : OL1) (Continued)

	Label	Direction	Magnitude[lb,lb-ft]
9	R3D_N133	X	1.857
10	R3D_N133	Y	793.181
11	R3D_N133	Z	-105.23
12	R3D_N109	Y	-4306.661
13	R3D_N109	Z	2680.349
14	R3D_N110A	X	-18.352
15	R3D_N110A	Y	936.447
16	R3D_N110A	Z	-102.47
17	R3D_N121	Y	-3931.509
18	R3D_N121	Z	2282.101
19	R3D_N122	X	1.413
20	R3D_N122	Y	742.992
21	R3D_N122	Z	-103.148
22	R3D_N133B_1	Y	-4017.107
23	R3D_N133B_1	Z	2370.943
24	R3D_N134B	X	-1.429
25	R3D_N134B	Y	793.641
26	R3D_N134B	Z	-105.224
27	R3D_N151	Y	-3933.38
28	R3D_N151	Z	2284.191
29	R3D_N152	X	-1.037
30	R3D_N152	Y	745.076
31	R3D_N152	Z	-103.229
32	R3D_N143A_1	X	-127.903
33	R3D_N143A_1	Y	-1931.443
34	R3D_N143A_1	Z	1036.861
35	R3D_N144A_1	X	-39.138
36	R3D_N144A_1	Y	297.367
37	R3D_N144A_1	Z	-63.614
38	R3D_N149A	Y	-4304.28
39	R3D_N149A	Z	2676.557
40	R3D_N150A	X	18.971
41	R3D_N150A	Y	934.122
42	R3D_N150A	Z	-102.614

Point Loads and Moments (Cat 17 : OL2)

	Label	Direction	Magnitude[lb,lb-ft]
1	R3D_N1	X	167.272
2	R3D_N1	Y	-2133.964
3	R3D_N1	Z	846.869
4	R3D_N2_1	X	-15.662
5	R3D_N2_1	Y	729.509
6	R3D_N2_1	Z	-52.742
7	R3D_N132	Y	-4484.421
8	R3D_N132	Z	1997.486
9	R3D_N133	X	1.452
10	R3D_N133	Y	1768.987
11	R3D_N133	Z	-88.675
12	R3D_N109	X	-1.296
13	R3D_N109	Y	-4781.241
14	R3D_N109	Z	2262.066
15	R3D_N110A	X	-6.969
16	R3D_N110A	Y	2009.562
17	R3D_N110A	Z	-86.389
18	R3D_N121	Y	-4399
19	R3D_N121	Z	1921.981

Point Loads and Moments (Cat 17 : OL2) (Continued)

	Label	Direction	Magnitude[lb,lb-ft]
20	R3D_N122	X	-1.223
21	R3D_N122	Y	1701.822
22	R3D_N122	Z	-86.928
23	R3D_N133B_1	Y	-4484.887
24	R3D_N133B_1	Z	1998.077
25	R3D_N134B	Y	1769.506
26	R3D_N134B	Z	-88.671
27	R3D_N151	Y	-4401.079
28	R3D_N151	Z	1924.451
29	R3D_N152	X	1.796
30	R3D_N152	Y	1704.144
31	R3D_N152	Z	-87.006
32	R3D_N143A_1	X	-165.881
33	R3D_N143A_1	Y	-2189.023
34	R3D_N143A_1	Z	872.779
35	R3D_N144A_1	X	13.728
36	R3D_N144A_1	Y	751.965
37	R3D_N144A_1	Z	-53.619
38	R3D_N149A	Y	-4778.61
39	R3D_N149A	Z	2257.797
40	R3D_N150A	X	7.709
41	R3D_N150A	Y	2006.753
42	R3D_N150A	Z	-86.485

Point Loads and Moments (Cat 18 : OL3)

	Label	Direction	Magnitude[lb,lb-ft]
1	R3D_N1	X	-155.153
2	R3D_N1	Y	2251.826
3	R3D_N1	Z	-1193.725
4	R3D_N2_1	X	-43.003
5	R3D_N2_1	Y	-357.981
6	R3D_N2_1	Z	74.228
7	R3D_N132	Y	4802.961
8	R3D_N132	Z	-2810.931
9	R3D_N133	X	-2.198
10	R3D_N133	Y	-980.49
11	R3D_N133	Z	124.784
12	R3D_N109	Y	5148.723
13	R3D_N109	Z	-3178.542
14	R3D_N110A	X	21.454
15	R3D_N110A	Y	-1154.725
16	R3D_N110A	Z	121.512
17	R3D_N121	Y	4701.462
18	R3D_N121	Z	-2706.128
19	R3D_N122	X	-1.588
20	R3D_N122	Y	-920.073
21	R3D_N122	Z	122.316
22	R3D_N133B_1	Y	4803.464
23	R3D_N133B_1	Z	-2811.523
24	R3D_N134B	X	1.681
25	R3D_N134B	Y	-981.04
26	R3D_N134B	Z	124.776
27	R3D_N151	Y	4703.699
28	R3D_N151	Z	-2708.631
29	R3D_N152	X	1.133
30	R3D_N152	Y	-922.564

Load Combinations

Label	Solve	Service	A..SF	Cat..Fa...	Cat..Fa...	Cat..Fa...	Cat..Fa...	Cat..Fa...	Cat..Fa...	Cat..Fa...	Cat..Fa...	Cat..Fa...	C...	F...	C...	F...
1	1.0 D	Yes	Yes	1.5	DL	1										
2	1.0 D + 1....	Yes	Yes	1.5	DL	1	RLL	1								
3	1.0 D + 0....	Yes	Yes	1.5	DL	1	RLL		OL1	.6						
4	1.0 D + 0....	Yes	Yes	1.5	DL	1	RLL		OL2	.6						
5	1.0 D + 0....	Yes	Yes	1.5	DL	1	RLL		OL3	.6						
6	1.0 D + 0....	Yes	Yes	1.5	DL	1	RLL		OL4	.6						
7	1.0 D + 0....	Yes	Yes	1.5	DL	1	RLL		OL5	.6						
8	1.0 D + 0....	Yes	Yes	1.5	DL	1	RLL		OL6	.6						
9	1.0 D + 0....	Yes	Yes	1.5	DL	1	RLL	.75	OL1	.45						
10	1.0 D + 0....	Yes	Yes	1.5	DL	1	RLL	.75	OL2	.45						
11	1.0 D + 0....	Yes	Yes	1.5	DL	1	RLL	.75	OL3	.45						
12	1.0 D + 0....	Yes	Yes	1.5	DL	1	RLL	.75	OL4	.45						
13	1.0 D + 0....	Yes	Yes	1.5	DL	1	RLL	.75	OL5	.45						
14	1.0 D + 0....	Yes	Yes	1.5	DL	1	RLL	.75	OL6	.45						
15	0.9 D + 0....	Yes	Yes		DL	.9	RLL		OL1	.6						
16	0.9 D + 0....	Yes	Yes		DL	.9	RLL		OL2	.6						
17	0.9 D + 0....	Yes	Yes		DL	.9	RLL		OL3	.6						
18	0.9 D + 0....	Yes	Yes		DL	.9	RLL		OL4	.6						
19	0.9 D + 0....	Yes	Yes		DL	.9	RLL		OL5	.6						
20	0.9 D + 0....	Yes	Yes		DL	.9	RLL		OL6	.6						
21																
22	1.4D	Yes			DL	1.4										
23	1.2D+1.6SL	Yes			DL	1.2	RLL	1.6								
24	1.2D+1.6S...	Yes			DL	1.2	RLL	1.6	OL1	.5						
25	1.2D+1.6S...	Yes			DL	1.2	RLL	1.6	OL2	.5						
26	1.2D+1.6S...	Yes			DL	1.2	RLL	1.6	OL3	.5						
27	1.2D+1.6S...	Yes			DL	1.2	RLL	1.6	OL4	.5						
28	1.2D+1.6S...	Yes			DL	1.2	RLL	1.6	OL5	.5						
29	1.2D+1.6S...	Yes			DL	1.2	RLL	1.6	OL6	.5						
30	1.2D+1.0...	Yes			DL	1.2			OL1	1						
31	1.2D-1.0Wx	Yes			DL	1.2			OL2	1						
32	1.2D+1.0...	Yes			DL	1.2			OL3	1						
33	1.2D-1.0Wz	Yes			DL	1.2			OL4	1						
34	1.2D+1.0...	Yes			DL	1.2			OL5	1						
35	1.2D-1.0...	Yes			DL	1.2			OL6	1						
36	.9D+1.0Wx	Yes			DL	.9			OL1	1						
37	.9D-1.0Wx	Yes			DL	.9			OL2	1						
38	.9D+1.0Wz	Yes			DL	.9			OL3	1						
39	.9D-1.0Wz	Yes			DL	.9			OL4	1						
40	.9D+1.0W...	Yes			DL	.9			OL5	1						
41	.9D-1.0W90	Yes			DL	.9			OL6	1						

Design Strips

Label	Rebar Angle from Pl...	No. of Design Cuts	Design Rule
1 DS1	0	50	Typical
2 DS2	90	50	Typical

Load Categories

Category	Point Loads	Line Loads	Area Loads
1 DL	22		
2 RLL	28		
3 OL1	42		
4 OL2	42		
5 OL3	42		
6 OL4	42		
7 OL5	44		



Company : Vector Structural Engineering
 Designer : STB
 Job Number : U2716.0231.201
 Model Name : Ground Mount

Apr 2, 2021
 4:57 PM
 Checked By: JSP

Load Categories (Continued)

	Category	Point Loads	Line Loads	Area Loads
8	OL6	45		

Strip Reinforcing

	Label	UC Top	LC	Top Bars	Governing ...	UC Bot	LC	Bot B...	Gover...	UC Shear	LC	Governing De...
1	DS1	.019	27	#5@7in	DS1-X26	.036	37	#5@7in	DS1-...	.047	37	DS1-X15
2	DS2	.001	36	#5@6in	DS2-X26	.003	26	#5@6in	DS2-...	.007	26	DS2-X25

Slab Overturning Safety Factors (By Combination)

	LC	Slab	Angle[deg]	Mo-xx[lb-ft]	Ms-xx[lb-ft]	Mo-zz[lb-ft]	Ms-zz[lb-ft]	Ms-xx/Mo-xx	Ms-zz/Mo-zz
1	1	S1	0	0	39932.828	0	10306.4	9.999+	9.999+
2	1	S2	0	0	41133.303	0	10523.251	9.999+	9.999+
3	1	S3	0	0	40948.819	0	10492.87	9.999+	9.999+
4	1	S4	0	0	40980.357	0	10499.359	9.999+	9.999+
5	1	S5	0	0	40980.334	0	10499.364	9.999+	9.999+
6	1	S6	0	0	40948.851	0	10492.848	9.999+	9.999+
7	1	S7	0	0	41132.542	0	10531.228	9.999+	9.999+
8	1	S8	0	0	39957.136	0	10216.009	9.999+	9.999+
9	2	S1	0	0	45384.826	0	11995.141	9.999+	9.999+
10	2	S2	0	0	53881.909	0	13588.891	9.999+	9.999+
11	2	S3	0	0	52569.196	0	13384.408	9.999+	9.999+
12	2	S4	0	0	52790.855	0	13424.347	9.999+	9.999+
13	2	S5	0	0	52790.707	0	13424.398	9.999+	9.999+
14	2	S6	0	0	52569.328	0	13376.064	9.999+	9.999+
15	2	S7	0	0	53876.199	0	13652.426	9.999+	9.999+
16	2	S8	0	0	45553.816	0	11395.345	9.999+	9.999+
17	3	S1	0	10296.471	40081.144	1421.557	10306.4	3.893	7.25
18	3	S2	0	23927.306	40979.896	2552.436	10531.379	1.713	4.126
19	3	S3	0	21685.927	40895.71	2393.296	10492.87	1.886	4.384
20	3	S4	0	22187.035	40914.785	2419.529	10499.359	1.844	4.339
21	3	S5	0	22184.617	40914.847	2420.135	10499.364	1.844	4.338
22	3	S6	0	21696.348	40895.503	2392.628	10492.848	1.885	4.385
23	3	S7	0	23911.954	40979.626	2553.23	10531.228	1.714	4.125
24	3	S8	0	10569.82	40103.679	1451.063	10312.37	3.794	7.107
25	4	S1	0	11017.856	40081.144	1258.015	10306.4	3.638	8.193
26	4	S2	0	24958.588	40979.896	2089.917	10531.379	1.642	5.039
27	4	S3	0	22841.183	40895.71	2024.535	10492.87	1.79	5.183
28	4	S4	0	23315.022	40914.785	2036.535	10499.359	1.755	5.156
29	4	S5	0	23312.299	40914.847	2038.535	10499.364	1.755	5.15
30	4	S6	0	22852.97	40895.503	2025.125	10492.848	1.79	5.181
31	4	S7	0	24941.766	40979.626	2089.3	10531.228	1.643	5.041
32	4	S8	0	11305.723	40103.679	1283.2	10312.37	3.547	8.036
33	5	S1	0	1215.691	39932.828	0	11994.294	9.999+	9.999+
34	5	S2	0	5182.545	41133.303	0	13489.787	7.937	9.999+
35	5	S3	0	3760.143	40948.819	0	13331.056	9.999+	9.999+
36	5	S4	0	4116.183	40980.357	0	13363.907	9.956	9.999+
37	5	S5	0	4113.02	40980.334	0	13369.184	9.964	9.999+
38	5	S6	0	3774.098	40948.851	0	13327.169	9.999+	9.999+
39	5	S7	0	5164.536	41132.542	0	13556.648	7.964	9.999+
40	5	S8	0	1272.48	39957.136	0	11402.97	9.999+	9.999+
41	6	S1	0	0	40646.93	0	11716.617	9.999+	9.999+
42	6	S2	0	0	41257.715	0	13131.019	9.999+	9.999+
43	6	S3	0	0	41694.586	0	12950.021	9.999+	9.999+
44	6	S4	0	0	41521.726	0	12983.523	9.999+	9.999+
45	6	S5	0	0	41523.726	0	12988.671	9.999+	9.999+
46	6	S6	0	0	41685.525	0	12940.589	9.999+	9.999+
47	6	S7	0	0	41267.951	0	13210.037	9.999+	9.999+



Slab Overturning Safety Factors (By Combination) (Continued)

LC	Slab	Angle[deg]	Mo-xx[lb-ft]	Ms-xx[lb-ft]	Mo-zz[lb-ft]	Ms-zz[lb-ft]	Ms-xx/Mo-xx	Ms-zz/Mo-zz
48	6	S8	0	0	40673.804	0	11218.902	9.999+
49	7	S1	0	504.277	39932.828	0	10946.168	9.999+
50	7	S2	0	1751.525	41133.303	0	11483.329	9.999+
51	7	S3	0	815.957	40948.819	0	11196.444	9.999+
52	7	S4	0	615.05	40980.357	0	10897.308	9.999+
53	7	S5	0	528.939	40980.334	0	10897.283	9.999+
54	7	S6	0	510.329	40948.851	0	10892.417	9.999+
55	7	S7	0	730.642	41132.542	0	10934.772	9.999+
56	7	S8	0	158.512	39957.136	0	10381.761	9.999+
57	8	S1	0	4783.066	40081.144	647.973	10306.4	8.38
58	8	S2	0	8910.356	40979.896	965.63	10531.379	4.599
59	8	S3	0	5299.051	40895.71	594.137	10492.87	7.718
60	8	S4	0	3731.055	40914.785	404.445	10499.359	9.999+
61	8	S5	0	3659.784	40914.847	403.461	10499.364	9.999+
62	8	S6	0	3647.564	40895.503	405.166	10492.848	9.999+
63	8	S7	0	3871.244	40979.626	402.78	10531.228	9.999+
64	8	S8	0	1891.151	40103.679	278.714	10312.37	9.999+
65	9	S1	0	7722.353	44276.408	1066.168	11572.956	5.734
66	9	S2	0	17945.479	49517.288	1914.327	12872.871	2.759
67	9	S3	0	16264.445	49072.546	1794.972	12661.524	3.017
68	9	S4	0	16640.276	49168.117	1814.647	12693.1	2.955
69	9	S5	0	16638.463	49168.545	1815.101	12693.14	2.955
70	9	S6	0	16272.261	49071.136	1794.471	12661.451	3.016
71	9	S7	0	17933.965	49515.73	1914.922	12872.127	2.761
72	9	S8	0	7927.365	44399.8	1088.297	11605.718	5.601
73	10	S1	0	8263.392	44276.408	943.512	11572.956	5.358
74	10	S2	0	18718.941	49517.288	1567.438	12872.871	2.645
75	10	S3	0	17130.887	49072.546	1518.401	12655.522	2.865
76	10	S4	0	17486.267	49168.117	1527.401	12693.1	2.812
77	10	S5	0	17484.225	49168.545	1528.901	12693.14	2.812
78	10	S6	0	17139.728	49071.136	1518.844	12655.26	2.863
79	10	S7	0	18706.324	49515.73	1566.975	12872.127	2.647
80	10	S8	0	8479.292	44399.8	962.4	11605.718	5.236
81	11	S1	0	911.768	44021.827	0	12838.876	9.999+
82	11	S2	0	3886.908	50694.758	0	15047.383	9.999+
83	11	S3	0	2820.107	49664.102	0	14790.163	9.999+
84	11	S4	0	3087.137	49838.231	0	14841.511	9.999+
85	11	S5	0	3084.765	49838.114	0	14845.505	9.999+
86	11	S6	0	2830.574	49664.209	0	14781.001	9.999+
87	11	S7	0	3873.402	50690.285	0	15141.192	9.999+
88	11	S8	0	954.36	44154.646	0	11990.731	9.999+
89	12	S1	0	0	44557.403	0	12630.618	9.999+
90	12	S2	0	0	50788.066	0	14778.307	9.999+
91	12	S3	0	0	50223.427	0	14504.387	9.999+
92	12	S4	0	0	50244.258	0	14556.223	9.999+
93	12	S5	0	0	50245.658	0	14560.119	9.999+
94	12	S6	0	0	50216.714	0	14491.066	9.999+
95	12	S7	0	0	50791.842	0	14881.233	9.999+
96	12	S8	0	0	44692.147	0	11852.68	9.999+
97	13	S1	0	378.208	44021.827	0	12052.782	9.999+
98	13	S2	0	1313.644	50694.758	0	13542.54	9.999+
99	13	S3	0	611.967	49664.102	0	13189.204	9.999+
100	13	S4	0	461.288	49838.231	0	12991.561	9.999+
101	13	S5	0	396.704	49838.114	0	12991.578	9.999+
102	13	S6	0	382.747	49664.209	0	12954.937	9.999+
103	13	S7	0	547.981	50690.285	0	13174.785	9.999+
104	13	S8	0	118.884	44154.646	0	11224.825	9.999+



Slab Overturning Safety Factors (By Combination) (Continued)

LC	Slab	Angle[deg]	Mo-xx[lb-ft]	Ms-xx[lb-ft]	Mo-zz[lb-ft]	Ms-zz[lb-ft]	Ms-xx/Mo-xx	Ms-zz/Mo-zz	
105	14	S1	0	3587.299	44276.408	485.98	11572.956	9.999+	9.999+
106	14	S2	0	6682.767	49517.288	724.222	12872.871	7.41	9.999+
107	14	S3	0	3974.288	49072.546	445.603	12661.524	9.999+	9.999+
108	14	S4	0	2798.291	49168.117	303.334	12693.1	9.999+	9.999+
109	14	S5	0	2744.838	49168.545	302.596	12693.14	9.999+	9.999+
110	14	S6	0	2735.673	49071.136	303.874	12661.451	9.999+	9.999+
111	14	S7	0	2903.433	49515.73	301.676	12821.679	9.999+	9.999+
112	14	S8	0	1418.363	44399.8	209.035	11605.718	9.999+	9.999+
113	15	S1	0	10296.471	36073.03	1421.557	9275.76	3.503	6.525
114	15	S2	0	23927.306	36881.906	2552.436	9478.241	1.541	3.713
115	15	S3	0	21685.927	36806.139	2393.296	9443.583	1.697	3.946
116	15	S4	0	22187.035	36823.306	2419.529	9449.423	1.66	3.905
117	15	S5	0	22184.617	36823.363	2420.135	9449.428	1.66	3.905
118	15	S6	0	21696.348	36805.953	2392.628	9443.563	1.696	3.947
119	15	S7	0	23911.954	36881.664	2553.23	9478.105	1.542	3.712
120	15	S8	0	10569.82	36093.311	1451.063	9281.133	3.415	6.396
121	16	S1	0	11017.856	36073.03	1258.015	9275.76	3.274	7.373
122	16	S2	0	24958.588	36881.906	2089.917	9478.241	1.478	4.535
123	16	S3	0	22841.183	36806.139	2024.535	9443.583	1.611	4.665
124	16	S4	0	23315.022	36823.306	2036.535	9449.423	1.579	4.64
125	16	S5	0	23312.299	36823.363	2038.535	9449.428	1.58	4.635
126	16	S6	0	22852.97	36805.953	2025.125	9443.563	1.611	4.663
127	16	S7	0	24941.766	36881.664	2089.3	9478.105	1.479	4.536
128	16	S8	0	11305.723	36093.311	1283.2	9281.133	3.192	7.233
129	17	S1	0	1215.691	35939.546	0	10963.654	9.999+	9.999+
130	17	S2	0	5182.545	37019.973	0	12437.462	7.143	9.999+
131	17	S3	0	3760.143	36853.937	0	12281.769	9.801	9.999+
132	17	S4	0	4116.183	36882.321	0	12313.971	8.96	9.999+
133	17	S5	0	4113.02	36882.3	0	12319.248	8.967	9.999+
134	17	S6	0	3774.098	36853.966	0	12277.884	9.765	9.999+
135	17	S7	0	5164.536	37019.288	0	12503.525	7.168	9.999+
136	17	S8	0	1272.48	35961.423	0	10381.369	9.999+	9.999+
137	18	S1	0	0	36653.647	0	10685.977	9.999+	9.999+
138	18	S2	0	0	37144.385	0	12078.694	9.999+	9.999+
139	18	S3	0	0	37599.704	0	11900.734	9.999+	9.999+
140	18	S4	0	0	37423.69	0	11933.587	9.999+	9.999+
141	18	S5	0	0	37425.693	0	11938.734	9.999+	9.999+
142	18	S6	0	0	37590.64	0	11891.304	9.999+	9.999+
143	18	S7	0	0	37154.697	0	12156.914	9.999+	9.999+
144	18	S8	0	0	36678.091	0	10197.301	9.999+	9.999+
145	19	S1	0	504.277	35939.546	0	9915.528	9.999+	9.999+
146	19	S2	0	1751.525	37019.973	0	10431.004	9.999+	9.999+
147	19	S3	0	815.957	36853.937	0	10147.157	9.999+	9.999+
148	19	S4	0	615.05	36882.321	0	9847.372	9.999+	9.999+
149	19	S5	0	528.939	36882.3	0	9847.346	9.999+	9.999+
150	19	S6	0	510.329	36853.966	0	9843.132	9.999+	9.999+
151	19	S7	0	730.642	37019.288	0	9881.649	9.999+	9.999+
152	19	S8	0	158.512	35961.423	0	9360.16	9.999+	9.999+
153	20	S1	0	4783.066	36073.03	647.973	9275.76	7.542	9.999+
154	20	S2	0	8910.356	36881.906	965.63	9478.241	4.139	9.816
155	20	S3	0	5299.051	36806.139	594.137	9443.583	6.946	9.999+
156	20	S4	0	3731.055	36823.306	404.445	9449.423	9.869	9.999+
157	20	S5	0	3659.784	36823.363	403.461	9449.428	9.999+	9.999+
158	20	S6	0	3647.564	36805.953	405.166	9443.563	9.999+	9.999+
159	20	S7	0	3871.244	36881.664	402.78	9478.105	9.527	9.999+
160	20	S8	0	1891.151	36093.311	278.714	9281.133	9.999+	9.999+



Company : Vector Structural Engineering
 Designer : STB
 Job Number : U2716.0231.201
 Model Name : Ground Mount

Apr 2, 2021
 4:57 PM
 Checked By: JSP

Slab Sliding Safety Factors (By Combination)

	LC	Slab	Angle[deg]	Va-xx[lb]	Vr-xx[lb]	Va-zz[lb]	Vr-zz[lb]	SR-xx	SR-zz
1	1	S1	0	21.429	2461.964	0	2461.964	9.999+	9.999+
2	1	S2	0	1.806	2526.556	0	2526.556	9.999+	9.999+
3	1	S3	0	0	2518.289	0	2518.289	9.999+	9.999+
4	1	S4	0	0	2519.846	0	2519.846	9.999+	9.999+
5	1	S5	0	0	2519.847	0	2519.847	9.999+	9.999+
6	1	S6	0	0	2518.284	0	2518.284	9.999+	9.999+
7	1	S7	0	1.798	2526.524	0	2526.524	9.999+	9.999+
8	1	S8	0	21.413	2463.405	0	2463.405	9.999+	9.999+
9	2	S1	0	142.598	2801.831	0	2801.831	9.999+	9.999+
10	2	S2	0	14.328	3269.071	1.115	3269.071	9.999+	9.999+
11	2	S3	0	1.778	3211.298	0	3211.298	9.999+	9.999+
12	2	S4	0	0	3221.843	0	3221.843	9.999+	9.999+
13	2	S5	0	0	3221.856	0	3221.856	9.999+	9.999+
14	2	S6	0	1.834	3211.246	0	3211.246	9.999+	9.999+
15	2	S7	0	14.348	3268.834	1.223	3268.834	9.999+	9.999+
16	2	S8	0	142.553	2811.862	0	2811.862	9.999+	9.999+
17	3	S1	0	78.63	2174.822	566.467	2174.822	9.999+	3.839
18	3	S2	0	9.205	1919.917	1546.728	1919.917	9.999+	1.241
19	3	S3	0	.848	1944.356	1307.372	1944.356	9.999+	1.487
20	3	S4	0	.858	1939.622	1359.431	1939.622	9.999+	1.427
21	3	S5	0	1.114	1939.617	1359.131	1939.617	9.999+	1.427
22	3	S6	0	.622	1944.389	1308.577	1944.389	9.999+	1.486
23	3	S7	0	9.585	1919.895	1544.366	1919.895	9.999+	1.243
24	3	S8	0	78.811	2169.272	583.948	2169.272	9.999+	3.715
25	4	S1	0	69.537	2209.162	476.476	2209.162	9.999+	4.636
26	4	S2	0	3.153	2027.653	1305.406	2027.653	9.999+	1.553
27	4	S3	0	.734	2032.797	1101.032	2032.797	9.999+	1.846
28	4	S4	0	0	2031.078	1145.644	2031.078	9.999+	1.773
29	4	S5	0	.871	2031.069	1145.287	2031.069	9.999+	1.773
30	4	S6	0	1.077	2032.835	1102.467	2032.835	9.999+	1.844
31	4	S7	0	2.828	2027.59	1302.787	2027.59	9.999+	1.556
32	4	S8	0	69.878	2204.735	491.496	2204.735	9.999+	4.486
33	5	S1	0	140.322	2802.856	671.698	2802.856	9.999+	4.173
34	5	S2	0	14.679	3245.475	1834.218	3245.475	9.999+	1.769
35	5	S3	0	.953	3198.939	1550.287	3198.939	9.999+	2.063
36	5	S4	0	1.009	3207.883	1612.048	3207.883	9.999+	1.99
37	5	S5	0	1.319	3207.892	1611.688	3207.892	9.999+	1.99
38	5	S6	0	.68	3198.888	1551.731	3198.888	9.999+	2.061
39	5	S7	0	15.115	3245.433	1831.394	3245.433	9.999+	1.772
40	5	S8	0	140.51	2812.588	692.438	2812.588	9.999+	4.062
41	6	S1	0	118.616	2747.935	583.234	2747.935	9.999+	4.712
42	6	S2	0	17.5	3160.894	1588.739	3160.894	9.999+	1.99
43	6	S3	0	2.114	3106.864	1344.908	3106.864	9.999+	2.31
44	6	S4	0	1.074	3116.626	1397.803	3116.626	9.999+	2.23
45	6	S5	0	1.204	3116.631	1397.584	3116.631	9.999+	2.23
46	6	S6	0	2.014	3106.829	1345.787	3106.829	9.999+	2.309
47	6	S7	0	17.761	3160.818	1586.849	3160.818	9.999+	1.992
48	6	S8	0	118.611	2756.586	600.962	2756.586	9.999+	4.587
49	7	S1	0	64.835	2592.069	263.184	2592.069	9.999+	9.849
50	7	S2	0	15.887	2764.578	611.848	2764.578	9.999+	4.518
51	7	S3	0	1.342	2687.871	376.787	2687.871	9.999+	7.134
52	7	S4	0	1.369	2616.093	230.974	2616.093	9.999+	9.999+
53	7	S5	0	1.233	2616.013	223.21	2616.013	9.999+	9.999+
54	7	S6	0	1.197	2614.827	218.971	2614.827	9.999+	9.999+
55	7	S7	0	1.977	2623.278	257.61	2623.278	9.999+	9.999+
56	7	S8	0	46.248	2516.597	96.83	2516.597	9.999+	9.999+
57	8	S1	0	23.111	2330.502	265.993	2330.502	9.999+	8.762



Slab Sliding Safety Factors (By Combination) (Continued)

	LC	Slab	Angle[deg]	Va-xx[lb]	Vr-xx[lb]	Va-zz[lb]	Vr-zz[lb]	SR-xx	SR-zz
58	8	S2	0	14.183	2303.439	577.154	2303.439	9.999+	3.991
59	8	S3	0	.451	2375.939	314.128	2375.939	9.999+	7.564
60	8	S4	0	1.397	2423.534	230.014	2423.534	9.999+	9.999+
61	8	S5	0	1.275	2423.705	223.771	2423.705	9.999+	9.999+
62	8	S6	0	1.234	2421.71	218.861	2421.71	9.999+	9.999+
63	8	S7	0	1.676	2429.922	257.633	2429.922	9.999+	9.432
64	8	S8	0	3.688	2410.069	96.828	2410.069	9.999+	9.999+
65	9	S1	0	37.262	2501.508	424.85	2501.508	9.999+	5.888
66	9	S2	0	2.939	2628.463	1159.209	2628.463	9.999+	2.267
67	9	S3	0	.698	2607.596	980.529	2607.596	9.999+	2.659
68	9	S4	0	.643	2611.176	1019.574	2611.176	9.999+	2.561
69	9	S5	0	.836	2611.18	1019.349	2611.18	9.999+	2.562
70	9	S6	0	.909	2607.584	981.433	2607.584	9.999+	2.657
71	9	S7	0	2.674	2628.285	1157.357	2628.285	9.999+	2.271
72	9	S8	0	37.1	2504.147	437.961	2504.147	9.999+	5.718
73	10	S1	0	44.081	2527.263	357.357	2527.263	9.999+	7.072
74	10	S2	0	7.479	2709.266	978.218	2709.266	9.999+	2.77
75	10	S3	0	1.884	2673.926	825.774	2673.926	9.999+	3.238
76	10	S4	0	0	2679.768	859.233	2679.768	9.999+	3.119
77	10	S5	0	.653	2679.77	858.965	2679.77	9.999+	3.12
78	10	S6	0	2.184	2673.919	826.85	2673.919	9.999+	3.234
79	10	S7	0	7.741	2709.056	976.173	2709.056	9.999+	2.775
80	10	S8	0	43.799	2530.745	368.622	2530.745	9.999+	6.865
81	11	S1	0	201.476	2972.533	503.773	2972.533	9.999+	5.901
82	11	S2	0	20.852	3622.632	1376.5	3622.632	9.999+	2.632
83	11	S3	0	2.049	3548.533	1162.716	3548.533	9.999+	3.052
84	11	S4	0	.757	3562.371	1209.036	3562.371	9.999+	2.946
85	11	S5	0	.989	3562.387	1208.766	3562.387	9.999+	2.947
86	11	S6	0	1.886	3548.459	1163.799	3548.459	9.999+	3.049
87	11	S7	0	21.199	3622.439	1374.463	3622.439	9.999+	2.636
88	11	S8	0	201.591	2986.635	519.328	2986.635	9.999+	5.751
89	12	S1	0	185.196	2931.342	437.426	2931.342	9.999+	6.701
90	12	S2	0	22.968	3559.196	1192.391	3559.196	9.999+	2.985
91	12	S3	0	2.919	3479.476	1008.681	3479.476	9.999+	3.45
92	12	S4	0	.806	3493.929	1048.352	3493.929	9.999+	3.333
93	12	S5	0	.903	3493.941	1048.188	3493.941	9.999+	3.333
94	12	S6	0	2.886	3479.414	1009.34	3479.414	9.999+	3.447
95	12	S7	0	23.183	3558.977	1191.054	3558.977	9.999+	2.988
96	12	S8	0	185.167	2944.633	450.721	2944.633	9.999+	6.533
97	13	S1	0	144.861	2814.443	197.388	2814.443	9.999+	9.999+
98	13	S2	0	21.759	3261.959	459.723	3261.959	9.999+	7.095
99	13	S3	0	.328	3165.232	282.59	3165.232	9.999+	9.999+
100	13	S4	0	1.027	3118.529	173.231	3118.529	9.999+	9.999+
101	13	S5	0	.925	3118.478	167.407	3118.478	9.999+	9.999+
102	13	S6	0	2.274	3110.413	164.229	3110.413	9.999+	9.999+
103	13	S7	0	11.345	3155.822	194.125	3155.822	9.999+	9.999+
104	13	S8	0	130.894	2764.641	72.623	2764.641	9.999+	9.999+
105	14	S1	0	78.901	2618.268	199.495	2618.268	9.999+	9.999+
106	14	S2	0	.794	2916.105	432.029	2916.105	9.999+	6.75
107	14	S3	0	.996	2931.283	235.596	2931.283	9.999+	9.999+
108	14	S4	0	1.048	2974.11	172.51	2974.11	9.999+	9.999+
109	14	S5	0	.956	2974.247	167.828	2974.247	9.999+	9.999+
110	14	S6	0	.45	2965.575	164.146	2965.575	9.999+	9.999+
111	14	S7	0	11.119	3010.805	192.308	3010.805	9.999+	9.999+
112	14	S8	0	93.442	2684.745	72.621	2684.745	9.999+	9.999+
113	15	S1	0	80.773	1928.626	566.467	1928.626	9.999+	3.405
114	15	S2	0	9.386	1667.262	1546.728	1667.262	9.999+	1.078



Company : Vector Structural Engineering
Designer : STB
Job Number : U2716.0231.201
Model Name : Ground Mount

Apr 2, 2021
4:57 PM
Checked By: JSP

Envelope Slab Soil Pressures (Continued)

	Label	UC	LC	Soil Pressure[psf]	Allowable Bearing[psf]	Point
8	S8	.347	5	520.156	1500	N275



Company:		Date:	5/14/2018
Engineer:		Page:	1/6
Project:			
Address:			
Phone:			
E-mail:			

1. Project information

Customer company:
Customer contact name:
Customer e-mail:
Comment:

Project description:
Location:
Fastening description:

2. Input Data & Anchor Parameters

General

Design method: ACI 318-14
Units: Imperial units

Anchor Information:

Anchor type: Bonded anchor
Material: F1554 Grade 36
Diameter (inch): 0.375
Effective Embedment depth, h_{ef} (inch): 6.000
Code report: ICC-ES ESR-4057
Anchor category: -
Anchor ductility: Yes
 h_{min} (inch): 7.25
 c_{ac} (inch): 10.99
 c_{min} (inch): 1.75
 s_{min} (inch): 3.00

Base Material

Concrete: Normal-weight
Concrete thickness, h (inch): 30.00
State: Cracked
Compressive strength, f'_c (psi): 2500
 $\Psi_{c,v}$: 1.0
Reinforcement condition: B tension, B shear
Supplemental reinforcement: Not applicable
Reinforcement provided at corners: No
Ignore concrete breakout in tension: No
Ignore concrete breakout in shear: No
Hole condition: Dry concrete
Inspection: Periodic
Temperature range, Short/Long: 150/110°F
Ignore 6do requirement: Not applicable
Build-up grout pad: No

Base Plate

Length x Width x Thickness (inch): 4.75 x 4.75 x 0.31

Recommended Anchor

Anchor Name: SET-3G - SET-3G w/ 3/8"Ø F1554 Gr. 36
Code Report: ICC-ES ESR-4057





Company:		Date:	5/14/2018
Engineer:		Page:	2/6
Project:			
Address:			
Phone:			
E-mail:			

Load and Geometry

Load factor source: ACI 318 Section 5.3

Load combination: not set

Seismic design: No

Anchors subjected to sustained tension: No

Apply entire shear load at front row: No

Anchors only resisting wind and/or seismic loads: No

Strength level loads:

N_{ua} [lb]: 4525

V_{uax} [lb]: 175

V_{uay} [lb]: -3180

M_{ux} [ft-lb]: 0

M_{uy} [ft-lb]: 0

M_{uz} [ft-lb]: 0

<Figure 1>

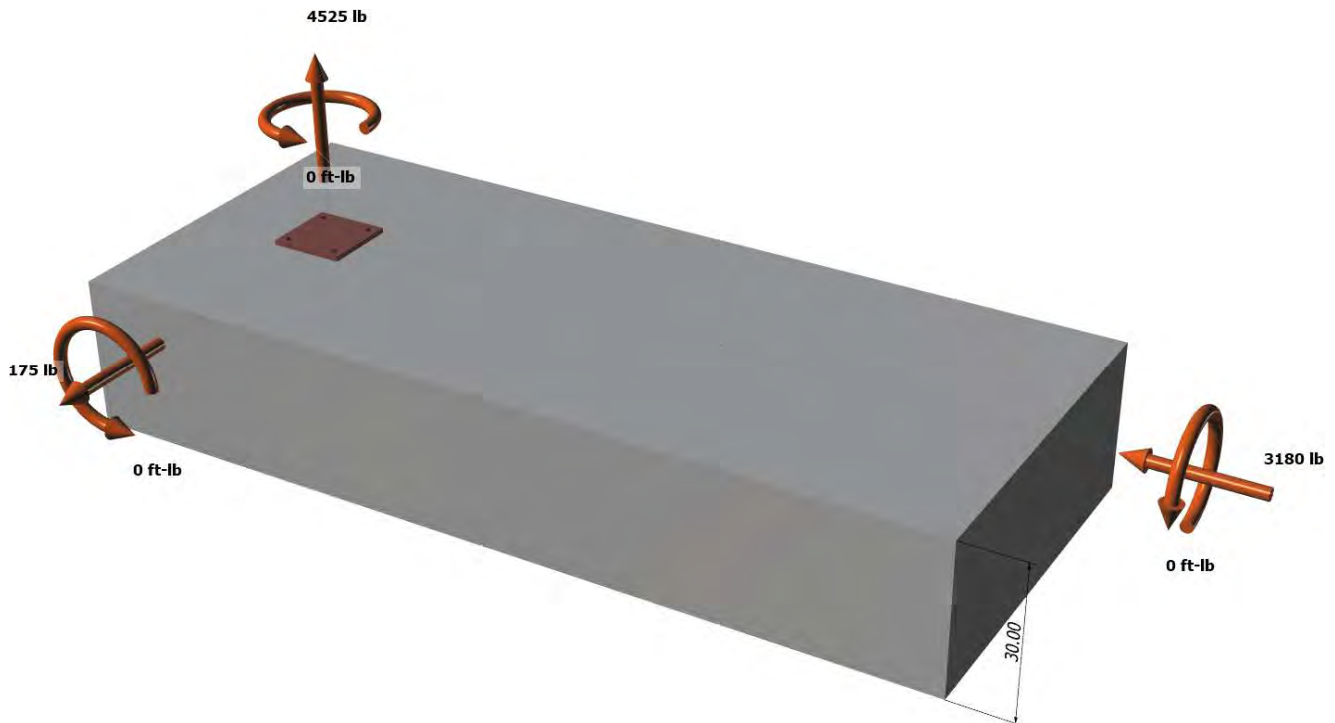



Company:		Date:	5/14/2018
Engineer:		Page:	3/6
Project:			
Address:			
Phone:			
E-mail:			

<Figure 2>

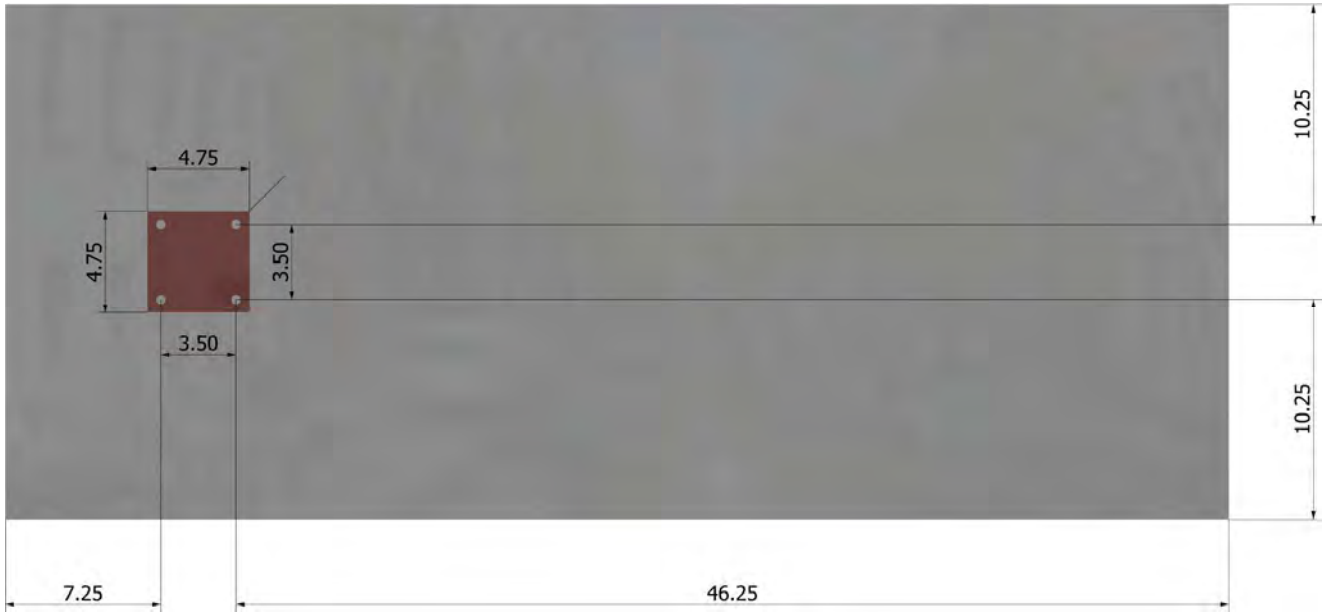



Company:		Date:	5/14/2018
Engineer:		Page:	4/6
Project:			
Address:			
Phone:			
E-mail:			

3. Resulting Anchor Forces

Anchor	Tension load, N_{ua} (lb)	Shear load x, V_{uax} (lb)	Shear load y, V_{uay} (lb)	Shear load combined, $\sqrt{(V_{uax})^2 + (V_{uay})^2}$ (lb)
1	1131.3	43.8	-795.0	796.2
2	1131.3	43.8	-795.0	796.2
3	1131.3	43.8	-795.0	796.2
4	1131.3	43.8	-795.0	796.2
Sum	4525.0	175.0	-3180.0	3184.8

Maximum concrete compression strain (%): 0.00
 Maximum concrete compression stress (psi): 0
 Resultant tension force (lb): 4525
 Resultant compression force (lb): 0
 Eccentricity of resultant tension forces in x-axis, e'_{Nx} (inch): 0.00
 Eccentricity of resultant tension forces in y-axis, e'_{Ny} (inch): 0.00
 Eccentricity of resultant shear forces in x-axis, e'_{Vx} (inch): 0.00
 Eccentricity of resultant shear forces in y-axis, e'_{Vy} (inch): 0.00

<Figure 3>

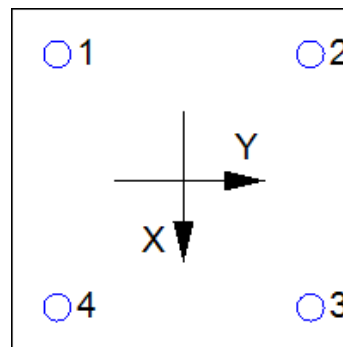

4. Steel Strength of Anchor in Tension (Sec. 17.4.1)

N_{sa} (lb)	ϕ	ϕN_{sa} (lb)
4525	0.75	3394

5. Concrete Breakout Strength of Anchor in Tension (Sec. 17.4.2)

$$N_b = K_c \lambda_a \sqrt{f_c} h_{ef}^{1.5} \text{ (Eq. 17.4.2.2a)}$$

K_c	λ_a	f_c (psi)	h_{ef} (in)	N_b (lb)
17.0	1.00	2500	6.000	12492

$$\phi N_{cbg} = \phi (A_{Nc} / A_{Nco}) \Psi_{ec,N} \Psi_{ed,N} \Psi_{c,N} \Psi_{cp,N} N_b \text{ (Sec. 17.3.1 \& Eq. 17.4.2.1b)}$$

A_{Nc} (in ²)	A_{Nco} (in ²)	$c_{a,min}$ (in)	$\Psi_{ec,N}$	$\Psi_{ed,N}$	$\Psi_{c,N}$	$\Psi_{cp,N}$	N_b (lb)	ϕ	ϕN_{cbg} (lb)
424.63	324.00	7.25	1.000	0.942	1.00	1.000	12492	0.65	10021

6. Adhesive Strength of Anchor in Tension (Sec. 17.4.5)

$$\tau_{k,cr} = \tau_{k,cr,short-term} K_{sat} (f_c / 2,500)^n$$

$\tau_{k,cr}$ (psi)	$f_{short-term}$	K_{sat}	f_c (psi)	n	$\tau_{k,cr}$ (psi)
1346	1.00	1.00	2500	0.24	1346

$$N_{ba} = \lambda_a \tau_{cr} \pi d_a h_{ef} \text{ (Eq. 17.4.5.2)}$$

λ_a	τ_{cr} (psi)	d_a (in)	h_{ef} (in)	N_{ba} (lb)
1.00	1346	0.38	6.000	9514

$$\phi N_{ag} = \phi (A_{Na} / A_{Na0}) \Psi_{ec,Na} \Psi_{ed,Na} \Psi_{cp,Na} N_{ba} \text{ (Sec. 17.3.1 \& Eq. 17.4.5.1b)}$$

A_{Na} (in ²)	A_{Na0} (in ²)	c_{Na} (in)	$c_{a,min}$ (in)	$\Psi_{ec,Na}$	$\Psi_{ed,Na}$	$\Psi_{cp,Na}$	N_{ba} (lb)	ϕ	ϕN_{ag} (lb)
198.45	112.09	5.29	7.25	1.000	1.000	1.000	9514	0.55	9265



Company:		Date:	5/14/2018
Engineer:		Page:	5/6
Project:			
Address:			
Phone:			
E-mail:			

8. Steel Strength of Anchor in Shear (Sec. 17.5.1)

V_{sa} (lb)	ϕ_{grout}	ϕ	$\phi_{grout}\phi V_{sa}$ (lb)
2715	1.0	0.65	1765

9. Concrete Breakout Strength of Anchor in Shear (Sec. 17.5.2)

Shear perpendicular to edge in x-direction:

$V_{bx} = \min|7(l_e / d_a)^{0.2} \sqrt{d_a} \lambda_a \sqrt{f_c} c_{a1}^{1.5}; 9 \lambda_a \sqrt{f_c} c_{a1}^{1.5}|$ (Eq. 17.5.2.2a & Eq. 17.5.2.2b)

l_e (in)	d_a (in)	λ_a	f_c (psi)	c_{a1} (in)	V_{bx} (lb)
3.00	0.375	1.00	2500	13.75	16564

$\phi V_{cbgx} = \phi (A_{vc} / A_{vco}) \Psi_{ec,v} \Psi_{ed,v} \Psi_{c,v} \Psi_{h,v} V_{bx}$ (Sec. 17.3.1 & Eq. 17.5.2.1b)

A_{vc} (in ²)	A_{vco} (in ²)	$\Psi_{ec,v}$	$\Psi_{ed,v}$	$\Psi_{c,v}$	$\Psi_{h,v}$	V_{bx} (lb)	ϕ	ϕV_{cbgx} (lb)
647.11	850.78	1.000	0.805	1.000	1.000	16564	0.70	7103

Shear perpendicular to edge in y-direction:

$V_{by} = \min|7(l_e / d_a)^{0.2} \sqrt{d_a} \lambda_a \sqrt{f_c} c_{a1}^{1.5}; 9 \lambda_a \sqrt{f_c} c_{a1}^{1.5}|$ (Eq. 17.5.2.2a & Eq. 17.5.2.2b)

l_e (in)	d_a (in)	λ_a	f_c (psi)	c_{a1} (in)	V_{by} (lb)
3.00	0.375	1.00	2500	10.75	11450

$\phi V_{cbgy} = \phi (A_{vc} / A_{vco}) \Psi_{ec,v} \Psi_{ed,v} \Psi_{c,v} \Psi_{h,v} V_{by}$ (Sec. 17.3.1 & Eq. 17.5.2.1b)

A_{vc} (in ²)	A_{vco} (in ²)	$\Psi_{ec,v}$	$\Psi_{ed,v}$	$\Psi_{c,v}$	$\Psi_{h,v}$	V_{by} (lb)	ϕ	ϕV_{cbgy} (lb)
387.00	520.03	1.000	0.891	1.000	1.000	11450	0.70	5313

Shear parallel to edge in x-direction:

$V_{by} = \min|7(l_e / d_a)^{0.2} \sqrt{d_a} \lambda_a \sqrt{f_c} c_{a1}^{1.5}; 9 \lambda_a \sqrt{f_c} c_{a1}^{1.5}|$ (Eq. 17.5.2.2a & Eq. 17.5.2.2b)

l_e (in)	d_a (in)	λ_a	f_c (psi)	c_{a1} (in)	V_{by} (lb)
3.00	0.375	1.00	2500	7.25	6342

$\phi V_{cbgx} = \phi (2)(A_{vc} / A_{vco}) \Psi_{ec,v} \Psi_{ed,v} \Psi_{c,v} \Psi_{h,v} V_{by}$ (Sec. 17.3.1, 17.5.2.1(c) & Eq. 17.5.2.1b)

A_{vc} (in ²)	A_{vco} (in ²)	$\Psi_{ec,v}$	$\Psi_{ed,v}$	$\Psi_{c,v}$	$\Psi_{h,v}$	V_{by} (lb)	ϕ	ϕV_{cbgx} (lb)
261.00	236.53	1.000	1.000	1.000	1.000	6342	0.70	9797

Shear parallel to edge in y-direction:

$V_{bx} = \min|7(l_e / d_a)^{0.2} \sqrt{d_a} \lambda_a \sqrt{f_c} c_{a1}^{1.5}; 9 \lambda_a \sqrt{f_c} c_{a1}^{1.5}|$ (Eq. 17.5.2.2a & Eq. 17.5.2.2b)

l_e (in)	d_a (in)	λ_a	f_c (psi)	c_{a1} (in)	V_{bx} (lb)
3.00	0.375	1.00	2500	10.25	10661

$\phi V_{cbgy} = \phi (2)(A_{vc} / A_{vco}) \Psi_{ec,v} \Psi_{ed,v} \Psi_{c,v} \Psi_{h,v} V_{bx}$ (Sec. 17.3.1, 17.5.2.1(c) & Eq. 17.5.2.1b)

A_{vc} (in ²)	A_{vco} (in ²)	$\Psi_{ec,v}$	$\Psi_{ed,v}$	$\Psi_{c,v}$	$\Psi_{h,v}$	V_{bx} (lb)	ϕ	ϕV_{cbgy} (lb)
401.67	472.78	1.000	1.000	1.000	1.000	10661	0.70	12680

10. Concrete Pryout Strength of Anchor in Shear (Sec. 17.5.3)

$\phi V_{cp} = \phi \min|k_{cp} N_{ag}; k_{cp} N_{cbg}| = \phi \min|k_{cp} (A_{Na} / A_{Na0}) \Psi_{ec,Na} \Psi_{ed,Na} \Psi_{cp,Na} N_{ba}; k_{cp} (A_{Nc} / A_{Nco}) \Psi_{ec,N} \Psi_{ed,N} \Psi_{cp,N} N_b|$ (Sec. 17.3.1 & Eq. 17.5.3.1b)

k_{cp}	A_{Na} (in ²)	A_{Na0} (in ²)	$\Psi_{ed,Na}$	$\Psi_{ec,Na}$	$\Psi_{cp,Na}$	N_{ba} (lb)	N_a (lb)
2.0	198.45	112.09	1.000	1.000	1.000	9514	16845

A_{Nc} (in ²)	A_{Nco} (in ²)	$\Psi_{ec,N}$	$\Psi_{ed,N}$	$\Psi_{c,N}$	$\Psi_{cp,N}$	N_b (lb)	N_{cb} (lb)	ϕ
424.63	324.00	1.000	0.942	1.000	1.000	12492	15417	0.70

Input data and results must be checked for agreement with the existing circumstances, the standards and guidelines must be checked for plausibility.



Company:		Date:	5/14/2018
Engineer:		Page:	6/6
Project:			
Address:			
Phone:			
E-mail:			

ϕV_{cpq} (lb)
21584

11. Results

Interaction of Tensile and Shear Forces (Sec. R17.6)

Tension	Factored Load, N_{ua} (lb)	Design Strength, ϕN_n (lb)	Ratio	Status	
Steel	1131	3394	0.33	Pass	
Concrete breakout	4525	10021	0.45	Pass	
Adhesive	4525	9265	0.49	Pass (Governs)	
Shear	Factored Load, V_{ua} (lb)	Design Strength, ϕV_n (lb)	Ratio	Status	
Steel	796	1765	0.45	Pass	
T Concrete breakout x+	175	7103	0.02	Pass	
T Concrete breakout y-	3180	5313	0.60	Pass	
Concrete breakout y-	88	9797	0.01	Pass	
Concrete breakout x-	1590	12680	0.13	Pass	
Concrete breakout, combined	-	-	0.60	Pass (Governs)	
Pryout	3185	21584	0.15	Pass	
Interaction check	$(N_{ua}/\phi N_{ua})^{5/3}$	$(V_{ua}/\phi V_{ua})^{5/3}$	Combined Ratio	Permissible	Status
Sec. R17.6	0.30	0.43	72.9%	1.0	Pass

SET-3G w/ 3/8"Ø F1554 Gr. 36 with hef = 6.000 inch meets the selected design criteria.

12. Warnings

- Designer must exercise own judgement to determine if this design is suitable.
- Refer to manufacturer's product literature for hole cleaning and installation instructions.



JOB NO.: U2716-0231-201

DESIGNED: STB

Framing Analysis

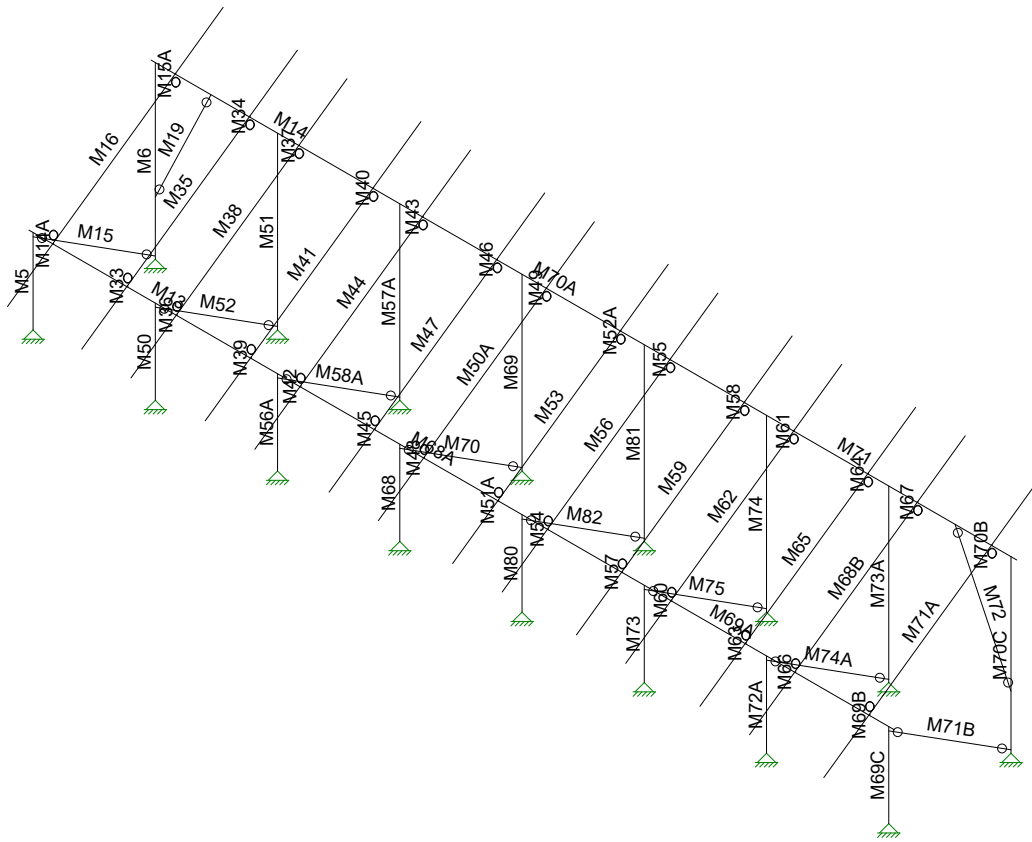

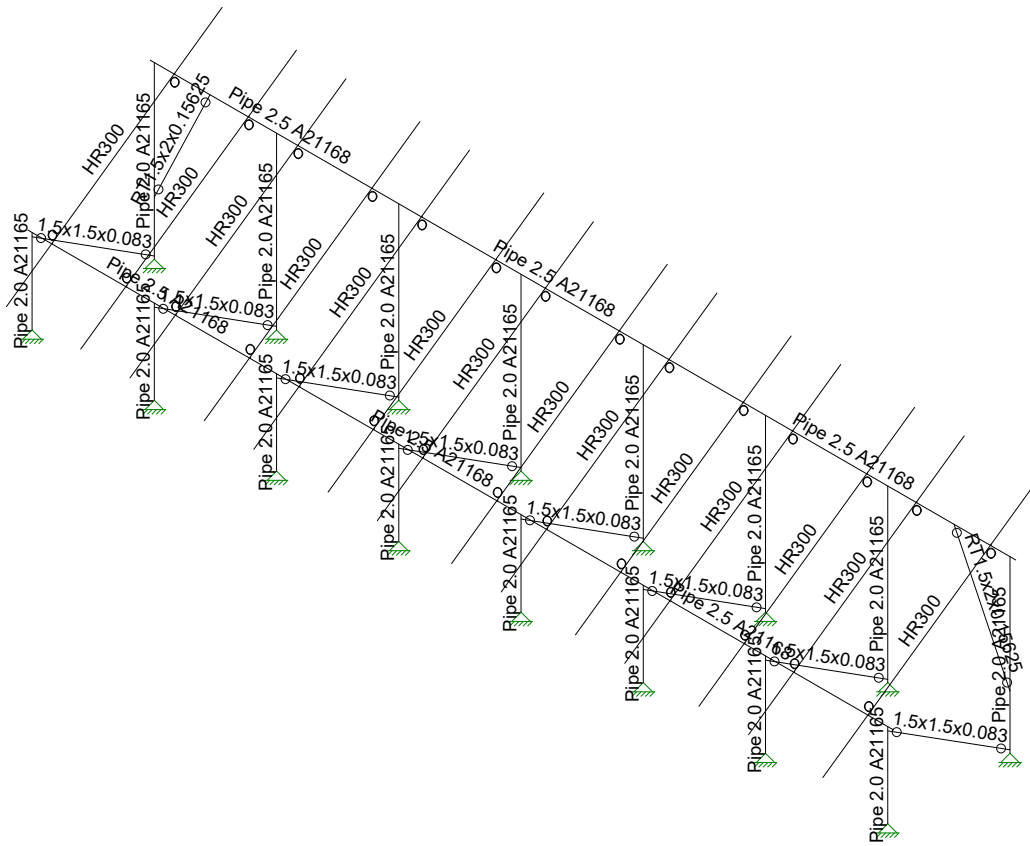

Envelope Only Solution

Vector Structural Engineeri...

STB

U2716.0231.201

Ground Mount

SK - 5

Apr 2, 2021 at 4:44 PM

Sunmodo Sunturf A5a v3 85x45.r3d

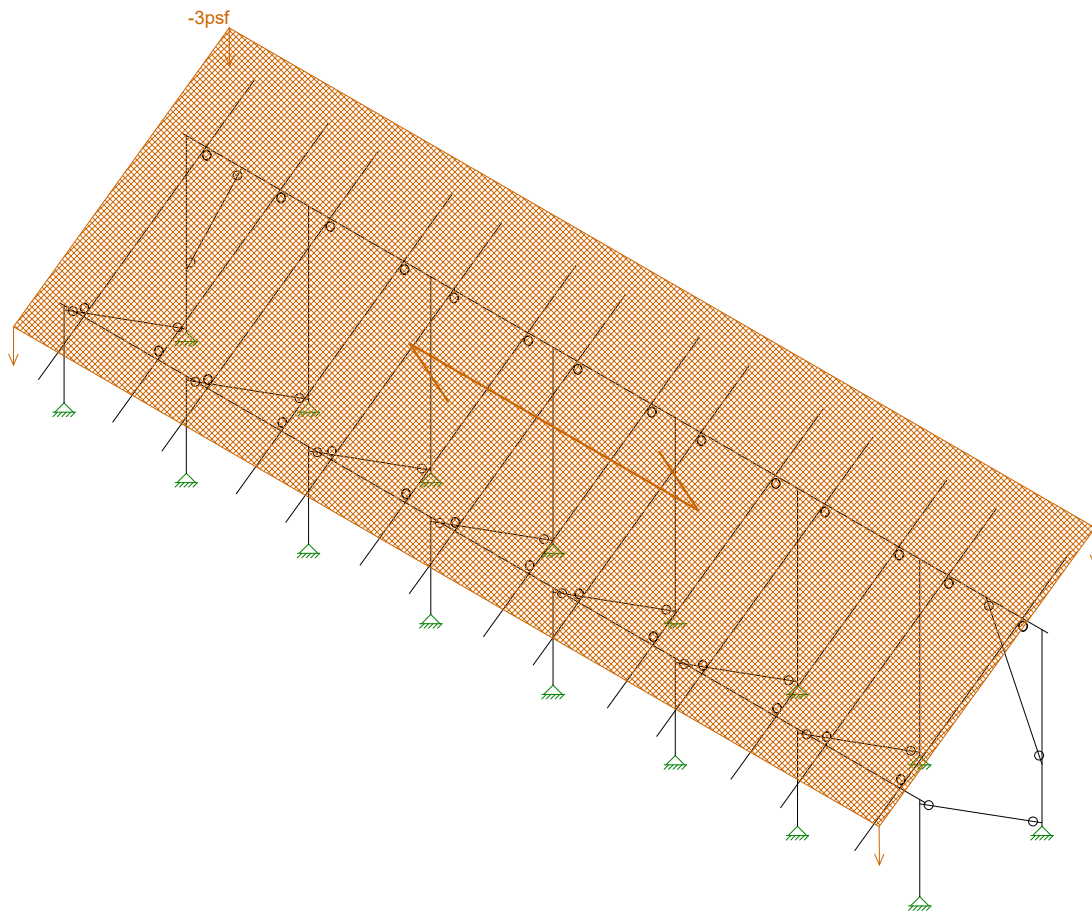

Loads: BLC 2, Solar Panel Weight
Envelope Only Solution

Vector Structural Engineeri...	Ground Mount	SK - 6
STB		Apr 2, 2021 at 4:44 PM
U2716.0231.201		Sunmodo Sunturf A5a v3 85x45.r3d

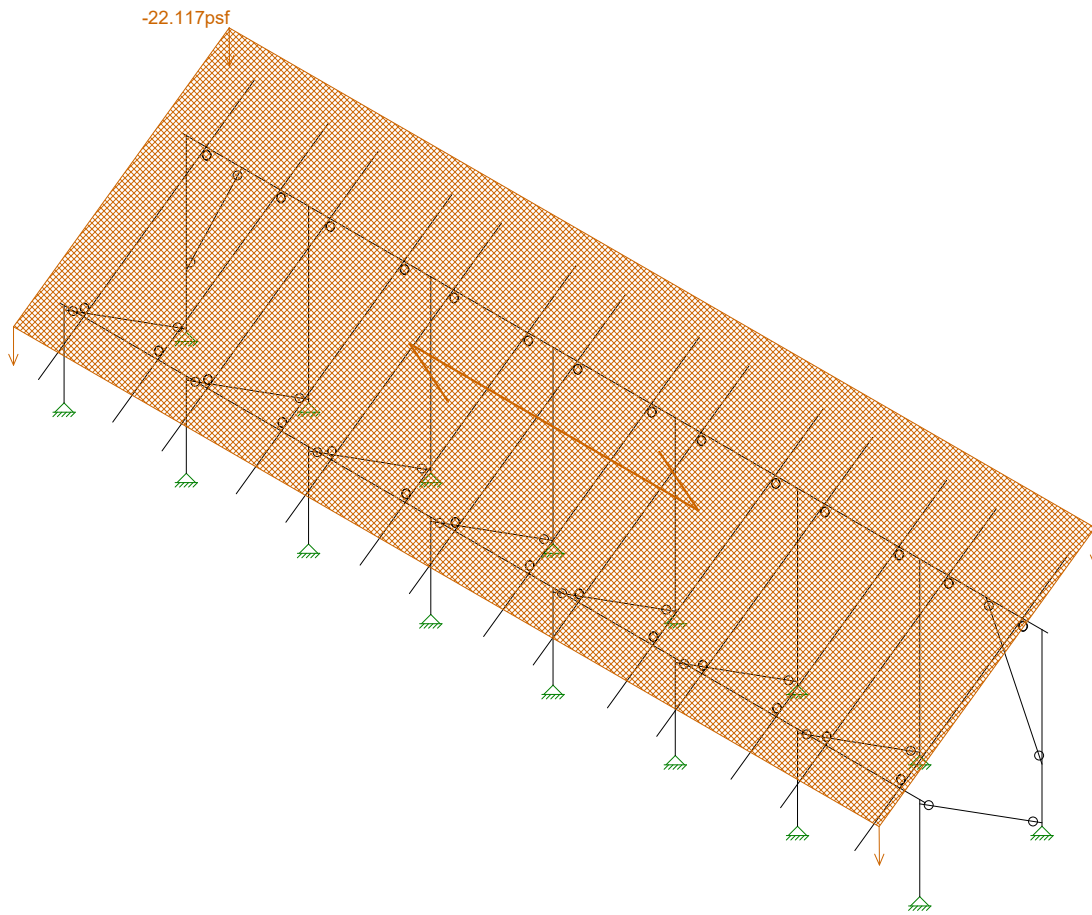

Loads: BLC 3, Roof Live/Snow
Envelope Only Solution

Vector Structural Engineeri...
STB
U2716.0231.201

Ground Mount

SK - 7

Apr 2, 2021 at 4:44 PM

Sunmodo Sunturf A5a v3 85x45.r3d

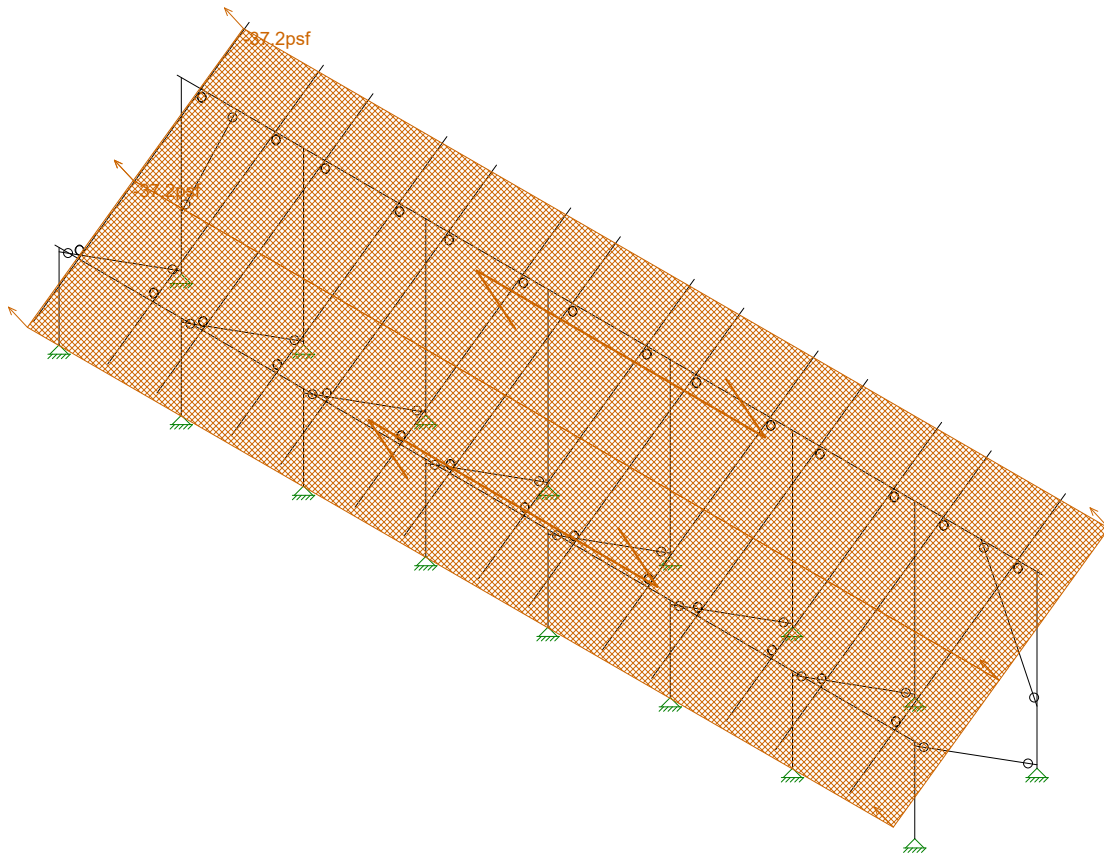

Loads: BLC 4, Wind A 0 deg
Envelope Only Solution

Vector Structural Engineeri...
STB
U2716.0231.201

Ground Mount

SK - 8

Apr 2, 2021 at 4:44 PM

Sunmodo Sunturf A5a v3 85x45.r3d

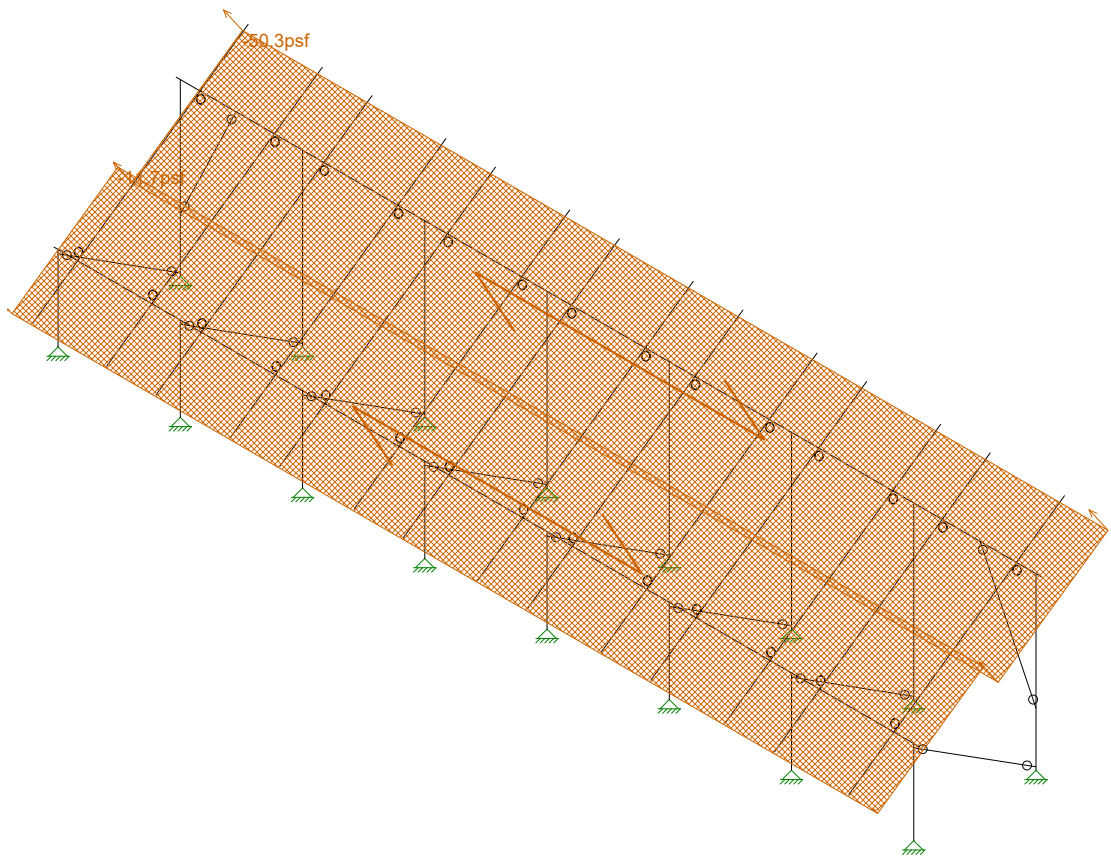

Loads: BLC 5, Wind B 0 deg
Envelope Only Solution

Vector Structural Engineeri...	Ground Mount	SK - 9
STB		Apr 2, 2021 at 4:44 PM
U2716.0231.201		Sunmodo Sunturf A5a v3 85x45.r3d

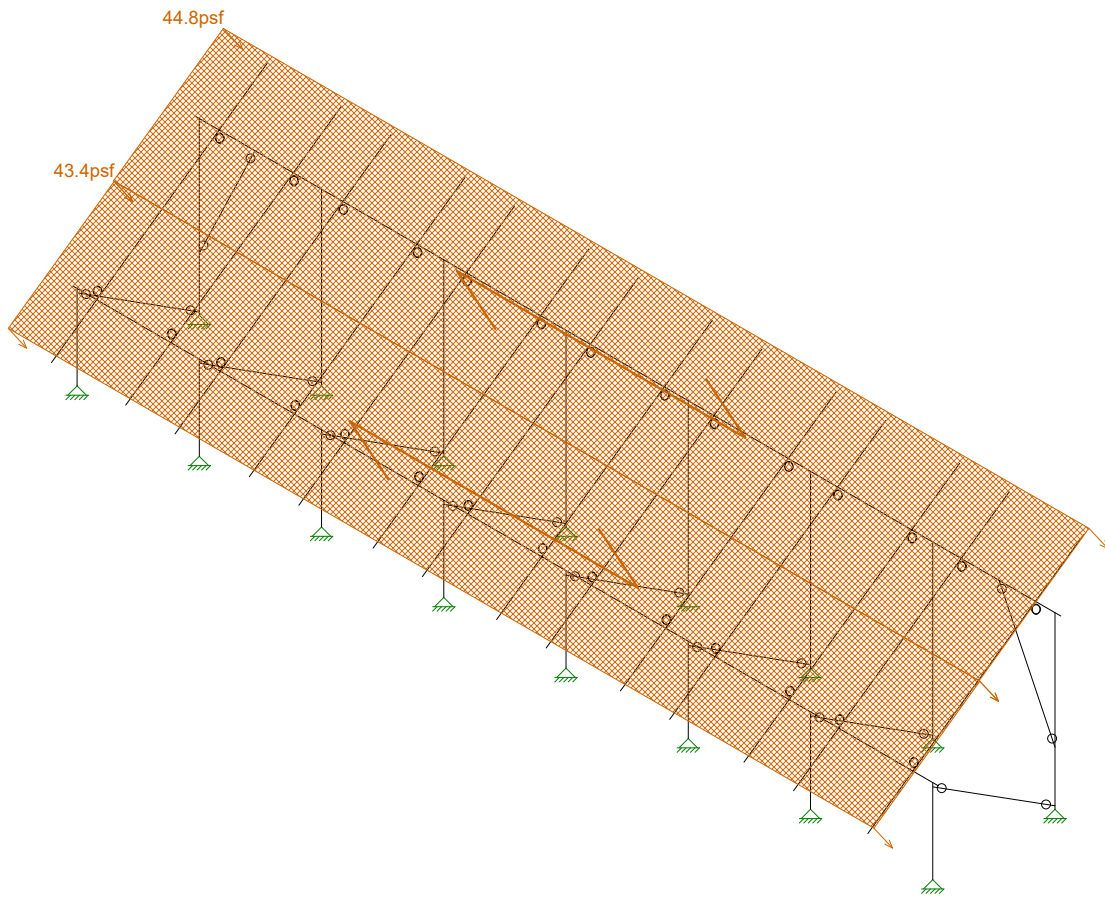

Loads: BLC 6, Wind A 180 deg
Envelope Only Solution

Vector Structural Engineeri...
STB
U2716.0231.201

Ground Mount

SK - 10

Apr 2, 2021 at 4:44 PM

Sunmodo Sunturf A5a v3 85x45.r3d

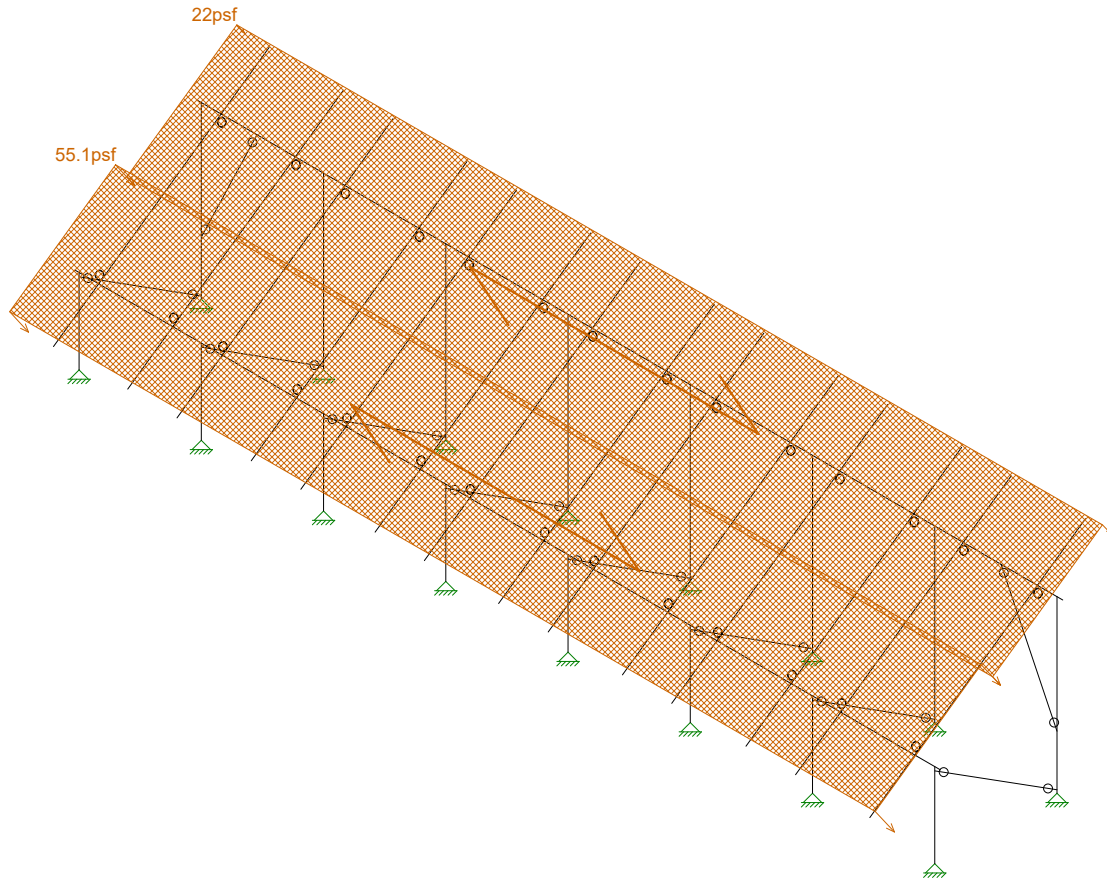

Loads: BLC 7, Wind B 180 deg
Envelope Only Solution

Vector Structural Engineeri...
STB
U2716.0231.201

Ground Mount

SK - 11

Apr 2, 2021 at 4:44 PM

Sunmodo Sunturf A5a v3 85x45.r3d

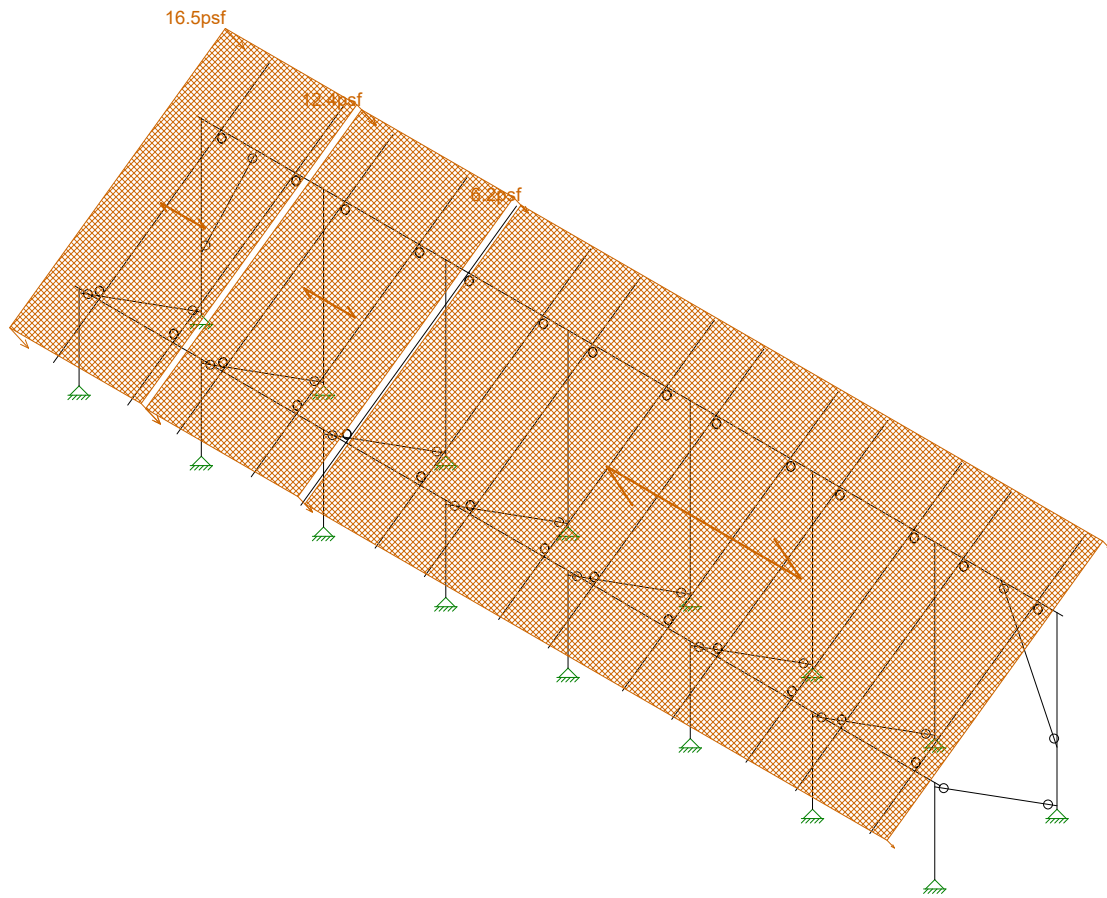

Loads: BLC 8, Wind A 90
Envelope Only Solution

Vector Structural Engineeri...
STB
U2716.0231.201

Ground Mount

SK - 12

Apr 2, 2021 at 4:44 PM

Sunmodo Sunturf A5a v3 85x45.r3d

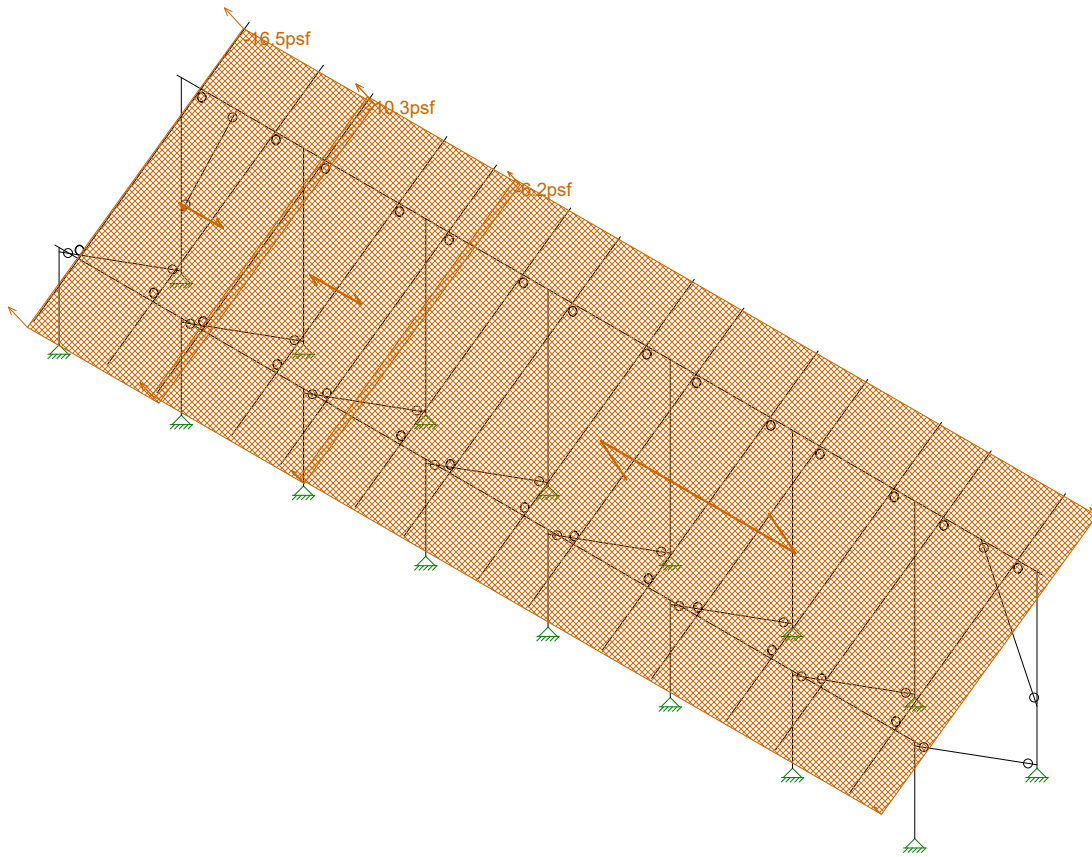

Loads: BLC 9, Wind B 90
Envelope Only Solution

Vector Structural Engineeri...
STB
U2716.0231.201

Ground Mount

SK - 13

Apr 2, 2021 at 4:44 PM

Sunmodo Sunturf A5a v3 85x45.r3d



Code Check (Env)	
Black	No Calc
Red	> 1.0
Magenta	.90-1.0
Green	.75-.90
Cyan	.50-.75
Blue	0-.50

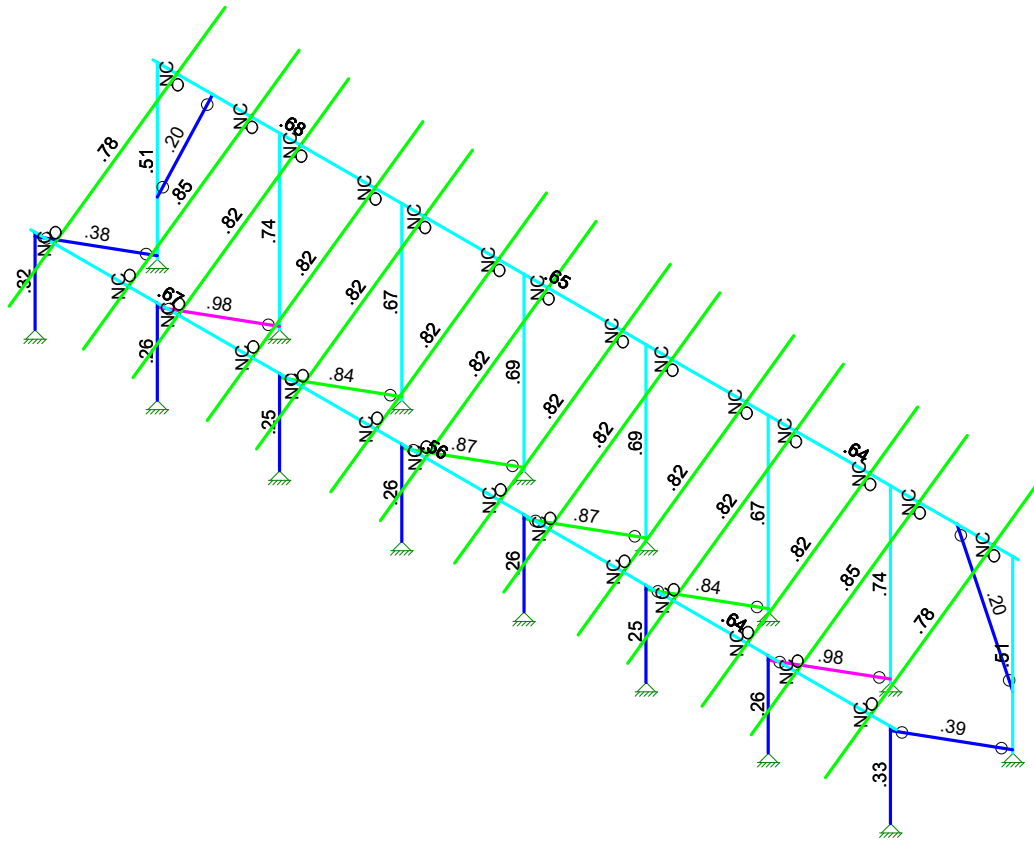

Member Code Checks Displayed (Enveloped)
Envelope Only Solution

Vector Structural Engineeri...	Ground Mount	SK - 3
STB		Apr 2, 2021 at 4:43 PM
U2716.0231.201		Sunmodo Sunturf A5a v3 85x45.r3d

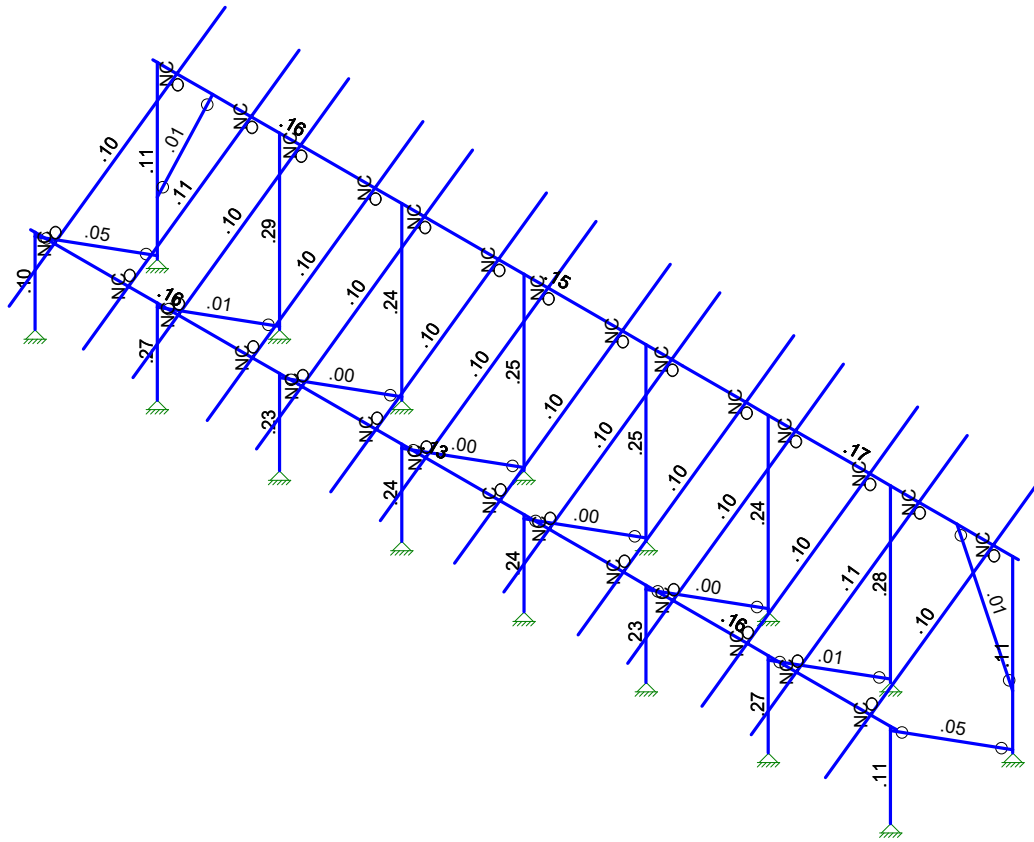
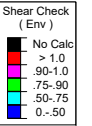

Member Shear Checks Displayed (Enveloped)
Envelope Only Solution

Vector Structural Engineeri...
STB
U2716.0231.201

Ground Mount

SK - 2

Apr 2, 2021 at 4:42 PM

Sunmodo Sunturf A5a v3 85x45.r3d

(Global) Model Settings

Display Sections for Member Calcs	5
Max Internal Sections for Member Calcs	97
Include Shear Deformation?	Yes
Increase Nailing Capacity for Wind?	Yes
Include Warping?	Yes
Trans Load Btwn Intersecting Wood Wall?	Yes
Area Load Mesh (in^2)	144
Merge Tolerance (in)	.12
P-Delta Analysis Tolerance	0.50%
Include P-Delta for Walls?	Yes
Automatically Iterate Stiffness for Walls?	Yes
Max Iterations for Wall Stiffness	3
Gravity Acceleration (in/sec^2)	386.4
Wall Mesh Size (in)	24
Eigensolution Convergence Tol. (1.E-)	4
Vertical Axis	Y
Global Member Orientation Plane	XZ
Static Solver	Sparse Accelerated
Dynamic Solver	Accelerated Solver

Hot Rolled Steel Code	AISC 15th(360-16): ASD
Adjust Stiffness?	Yes(Iterative)
RISACONNECTION CODE	AISC 15th(360-16): ASD
Cold Formed Steel Code	AISI S100-16: ASD
Wood Code	AWC NDS-18: ASD
Wood Temperature	< 100F
Concrete Code	ACI 318-14
Masonry Code	TMS 402-16: ASD
Aluminum Code	AA ADM1-15: ASD - Building
Stainless Steel Code	AISC 14th(360-10): ASD
Adjust Stiffness?	Yes(Iterative)

Number of Shear Regions	4
Region Spacing Increment (in)	4
Biaxial Column Method	Exact Integration
Parme Beta Factor (PCA)	.65
Concrete Stress Block	Rectangular
Use Cracked Sections?	Yes
Use Cracked Sections Slab?	No
Bad Framing Warnings?	No
Unused Force Warnings?	Yes
Min 1 Bar Diam. Spacing?	No
Concrete Rebar Set	REBAR SET ASTMA615
Min % Steel for Column	1
Max % Steel for Column	8



Company : Vector Structural Engineering
 Designer : STB
 Job Number : U2716.0231.201
 Model Name : Ground Mount

Apr 2, 2021
 4:45 PM
 Checked By: _____

Aluminum Section Sets

	Label	Shape	Type	Design List	Material	Design R...	A [in2]	Iyy [in4]	Izz [in4]	J [in4]
1	AL Posts	2.375ODX0.188	Column	Pipe	6005-T5	Typical	1.29	.778	.778	1.54
2	AL Brace	RT1.5x2x0.15625	VBrace	Rectangular Tubes	6005-T5	Typical	.996	.327	.524	.602
3	AL Rails	HR300	Beam	Rectangular Tubes	6005-T5	Typical	.74	.253	.727	.578
4	AL Cross Beam	Cross Rail	Beam	Rectangular Tubes	6005-T5	Typical	1.909	1.97	4.366	4.017

Member Area Loads (BLC 2 : Solar Panel Weight)

	Joint A	Joint B	Joint C	Joint D	Direction	Distribution	Magnitude[psf]
1	N197	N200	N199	N196	Y	A-B	-3

Member Area Loads (BLC 3 : Roof Live/Snow)

	Joint A	Joint B	Joint C	Joint D	Direction	Distribution	Magnitude[psf]
1	N197	N200	N199	N196	PY	A-B	-27

Member Area Loads (BLC 4 : Wind A 0 deg)

	Joint A	Joint B	Joint C	Joint D	Direction	Distribution	Magnitude[psf]
1	N197	N200	N201	N198	Perp	A-B	-37.2
2	N198	N201	N199	N196	Perp	A-B	-37.2

Member Area Loads (BLC 5 : Wind B 0 deg)

	Joint A	Joint B	Joint C	Joint D	Direction	Distribution	Magnitude[psf]
1	N197	N200	N201	N198	Perp	A-B	-50.3
2	N198	N201	N199	N196	Perp	A-B	-11.7

Member Area Loads (BLC 6 : Wind A 180 deg)

	Joint A	Joint B	Joint C	Joint D	Direction	Distribution	Magnitude[psf]
1	N197	N200	N201	N198	Perp	A-B	44.8
2	N198	N201	N199	N196	Perp	A-B	43.4

Member Area Loads (BLC 7 : Wind B 180 deg)

	Joint A	Joint B	Joint C	Joint D	Direction	Distribution	Magnitude[psf]
1	N197	N200	N201	N198	Perp	A-B	22
2	N198	N201	N199	N196	Perp	A-B	55.1

Member Area Loads (BLC 8 : Wind A 90)

	Joint A	Joint B	Joint C	Joint D	Direction	Distribution	Magnitude[psf]
1	N197	N203	N202	N196	Perp	A-B	16.5
2	N203	N209	N208	N202	Perp	A-B	12.4
3	N209	N200	N199	N208	Perp	A-B	6.2

Member Area Loads (BLC 9 : Wind B 90)

	Joint A	Joint B	Joint C	Joint D	Direction	Distribution	Magnitude[psf]
1	N197	N203	N202	N196	Perp	A-B	-16.5
2	N203	N209	N208	N202	Perp	A-B	-10.3
3	N209	N200	N199	N208	Perp	A-B	-6.2

Basic Load Cases

	BLC Description	Category	X Gravity	Y Gravity	Z Gravity	Joint	Point	Distributed	Area(M...Surface...
1	Self Weight	DL		-1.05					
2	Solar Panel Weight	DL							1



Company : Vector Structural Engineering
 Designer : STB
 Job Number : U2716.0231.201
 Model Name : Ground Mount

Apr 2, 2021
 4:45 PM
 Checked By: _____

Envelope Joint Reactions (Continued)

Joint	X [lb]	LC	Y [lb]	LC	Z [lb]	LC	MX [lb-ft]	LC	MY [lb-ft]	LC	MZ [lb-ft]	LC
14	min	-.88	19	-2500.765	16	-1370...	3	0	1	0	1	0
15	N122	max	3.248	12	1831.395	10	62.386	3	0	20	0	20
16		min	-1.476	20	-430.656	17	-73.551	5	0	1	0	1
17	N133B	max	1.502	20	3288.965	11	1687.0...	5	0	20	0	20
18		min	-1.118	19	-2548.117	16	-1423...	3	0	1	0	1
19	N134B	max	.749	15	1880.791	10	63.694	3	0	20	0	20
20		min	-1.436	11	-465.934	17	-74.971	5	0	1	0	1
21	N151	max	1.318	20	3228.143	11	1624.9...	5	0	20	0	20
22		min	-.969	19	-2501.924	16	-1371...	3	0	1	0	1
23	N152	max	.381	15	1832.475	10	62.437	3	0	20	0	20
24		min	-3.328	12	-432.151	17	-73.605	5	0	1	0	1
25	N143A	max	96.958	16	1640.317	11	737.653	17	0	20	0	20
26		min	-123.8...	11	-1231.941	16	-622.3...	3	0	1	0	1
27	N144A	max	18.443	15	852.68	10	38.198	3	0	20	0	20
28		min	-81.755	12	-160.321	17	-45.529	5	0	1	0	1
29	N149A	max	2.526	11	3497.52	11	1905.0...	5	0	20	0	20
30		min	-1.119	19	-2709.644	16	-1606...	3	0	1	0	1
31	N150A	max	22.066	12	2082.958	10	62.338	3	0	20	0	20
32		min	-10.187	15	-559.22	17	-72.92	5	0	1	0	1
33	Totals:	max	.016	8	27801.096	11	11355...	17				
34		min	-.016	7	-11737.97	15	-9576...	3				

Envelope AISC 15th(360-16): ASD Steel Code Checks

Member	Shape	Code Check	Loc[in]	LC	Shear	...	Loc[in]	Dir	LC	Pnc/om	[..Pnt/om	[lb]	Mnyy/om..	Mnzz/om..	Cb	Eqn
1	M5	Pipe 2.0 A2...	.324	55.52	12	.103	55.52	5	5	15864.376	23232.186	1397.505	1397.505	1...	H1-1b	
2	M6	Pipe 2.0 A2...	.506	36.579	11	.107	0	5	5	5476.236	23232.186	1397.505	1397.505	1...	H1-1a	
3	M13	Pipe 2.5 A2...	.666	86.25	12	.163	86.25	12	11641.036	28358.413	2081.747	2081.747	1...	H1-1b		
4	M14	Pipe 2.5 A2...	.679	86.25	11	.163	88.167	11	11641.036	28358.413	2081.747	2081.747	1...	H1-1b		
5	M15	1.5x1.5x0.083	.378	51.838	5	.050	99.528	y	11	2397.024	14085.15	624.421	624.421	1...	H1-1a	
6	M80	Pipe 2.0 A2...	.258	55.52	5	.238	55.52	5	5	15864.376	23232.186	1397.505	1397.505	1...	H1-1b	
7	M81	Pipe 2.0 A2...	.686	1.219	11	.252	0	5	5	5476.236	23232.186	1397.505	1397.505	1...	H1-1a	
8	M82	1.5x1.5x0.083	.869	51.838	5	.004	0	y	8	2397.024	14085.15	624.421	624.421	1...	H1-1a	
9	M50	Pipe 2.0 A2...	.257	54.917	17	.272	55.52	5	5	15864.376	23232.186	1397.505	1397.505	1...	H1-1b	
10	M51	Pipe 2.0 A2...	.740	1.219	5	.285	0	5	5	5476.236	23232.186	1397.505	1397.505	1...	H1-1a	
11	M52	1.5x1.5x0.083	.982	51.838	5	.011	0	y	13	2397.024	14085.15	624.421	624.421	1...	H1-1a	
12	M56A	Pipe 2.0 A2...	.253	55.52	5	.229	55.52	5	5	15864.376	23232.186	1397.505	1397.505	1...	H1-1b	
13	M57A	Pipe 2.0 A2...	.671	1.219	11	.242	0	5	5	5476.236	23232.186	1397.505	1397.505	1...	H1-1a	
14	M58A	1.5x1.5x0.083	.837	51.838	5	.004	0	y	14	2397.024	14085.15	624.421	624.421	1...	H1-1a	
15	M68	Pipe 2.0 A2...	.258	55.52	5	.238	55.52	5	5	15864.376	23232.186	1397.505	1397.505	1...	H1-1b	
16	M69	Pipe 2.0 A2...	.686	1.219	11	.252	0	5	5	5476.236	23232.186	1397.505	1397.505	1...	H1-1a	
17	M70	1.5x1.5x0.083	.869	51.838	5	.004	99.528	y	7	2397.024	14085.15	624.421	624.421	1...	H1-1a	
18	M68A	Pipe 2.5 A2...	.562	71.25	12	.127	0	12	11641.036	28358.413	2081.747	2081.747	2...	H1-1b		
19	M69A	Pipe 2.5 A2...	.635	144....	12	.159	144....	12	11641.036	28358.413	2081.747	2081.747	1...	H1-1b		
20	M70A	Pipe 2.5 A2...	.648	71.25	11	.148	153.75	11	11641.036	28358.413	2081.747	2081.747	2...	H1-1b		
21	M71	Pipe 2.5 A2...	.645	144....	11	.168	141....	11	11641.036	28358.413	2081.747	2081.747	1...	H1-1b		
22	M73	Pipe 2.0 A2...	.253	55.52	5	.229	55.52	5	5	15864.376	23232.186	1397.505	1397.505	1...	H1-1b	
23	M74	Pipe 2.0 A2...	.672	1.219	11	.242	0	5	5	5476.236	23232.186	1397.505	1397.505	1...	H1-1a	
24	M75	1.5x1.5x0.083	.837	51.838	5	.004	0	y	13	2397.024	14085.15	624.421	624.421	1...	H1-1a	
25	M69C	Pipe 2.0 A2...	.327	55.52	12	.107	55.52	5	5	15864.376	23232.186	1397.505	1397.505	1...	H1-1b	
26	M70C	Pipe 2.0 A2...	.513	36.579	11	.110	0	5	5	5476.236	23232.186	1397.505	1397.505	1...	H1-1a	
27	M71B	1.5x1.5x0.083	.388	51.838	5	.052	99.528	y	11	2397.024	14085.15	624.421	624.421	1...	H1-1a	
28	M72A	Pipe 2.0 A2...	.258	54.917	17	.271	55.52	5	5	15864.376	23232.186	1397.505	1397.505	1...	H1-1b	
29	M73A	Pipe 2.0 A2...	.740	1.219	5	.285	0	5	5	5476.236	23232.186	1397.505	1397.505	2...	H1-1a	
30	M74A	1.5x1.5x0.083	.980	51.838	5	.009	99.528	y	11	2397.024	14085.15	624.421	624.421	1...	H1-1a	



Company : Vector Structural Engineering
 Designer : STB
 Job Number : U2716.0231.201
 Model Name : Ground Mount

Apr 2, 2021
 4:45 PM
 Checked By: _____

Envelope AA ADM1-15: ASD - Building Aluminum Code Checks

Member	Shape	Code C...	Loc[in]	LC	Shear ...	Loc[in]	Dir	LC	Pnc/O...	Pnt/Om...	Mny/O...	Mnz/O...	Vny/O...	Vnz/O...	Cb	Eqn
1	M19	RT1.5x2x...	.197	55.45	11	.012	0	z	5	2133.443	19411....	770.742	927.083	5889.423	3966.346	1... H.1-1
2	M16	HR300	.780	37.714	12	.100	39.6	y	12	3885.189	14429....	560.361	900.347	5656.689	2605.145	1 H.1-1
3	M72	RT1.5x2x...	.197	55.517	11	.011	0	z	11	2128.272	19411....	770.742	927.083	5889.423	3966.346	1... H.1-1
4	M35	HR300	.845	37.714	12	.112	39.6	y	12	3885.189	14429....	560.361	900.347	5656.689	2605.145	1 H.1-1
5	M38	HR300	.817	141.4...	11	.103	39.6	y	12	3885.189	14429....	560.361	900.347	5656.689	2605.145	1 H.1-1
6	M41	HR300	.817	141.4...	11	.103	39.6	y	12	3885.189	14429....	560.361	900.347	5656.689	2605.145	1 H.1-1
7	M44	HR300	.816	141.4...	11	.102	39.6	y	12	3885.189	14429....	560.361	900.347	5656.689	2605.145	1 H.1-1
8	M47	HR300	.816	141.4...	11	.102	39.6	y	12	3885.189	14429....	560.361	900.347	5656.689	2605.145	1 H.1-1
9	M50A	HR300	.817	141.4...	11	.102	39.6	y	12	3885.189	14429....	560.361	900.347	5656.689	2605.145	1 H.1-1
10	M53	HR300	.816	141.4...	11	.102	39.6	y	12	3885.189	14429....	560.361	900.347	5656.689	2605.145	1 H.1-1
11	M56	HR300	.816	141.4...	11	.102	39.6	y	12	3885.189	14429....	560.361	900.347	5656.689	2605.145	1 H.1-1
12	M59	HR300	.816	141.4...	11	.102	39.6	y	12	3885.189	14429....	560.361	900.347	5656.689	2605.145	1 H.1-1
13	M62	HR300	.817	141.4...	11	.103	39.6	y	12	3885.189	14429....	560.361	900.347	5656.689	2605.145	1 H.1-1
14	M65	HR300	.816	141.4...	11	.103	39.6	y	12	3885.189	14429....	560.361	900.347	5656.689	2605.145	1 H.1-1
15	M68B	HR300	.845	37.714	12	.112	39.6	y	12	3885.189	14429....	560.361	900.347	5656.689	2605.145	1 H.1-1
16	M71A	HR300	.780	37.714	12	.100	39.6	y	12	3885.189	14429....	560.361	900.347	5656.689	2605.145	1 H.1-1

NOTES: UNLESS OTHERWISE SPECIFIED
 1. DIMENSIONS SHOWN ARE INCHES [MILLIMETERS].

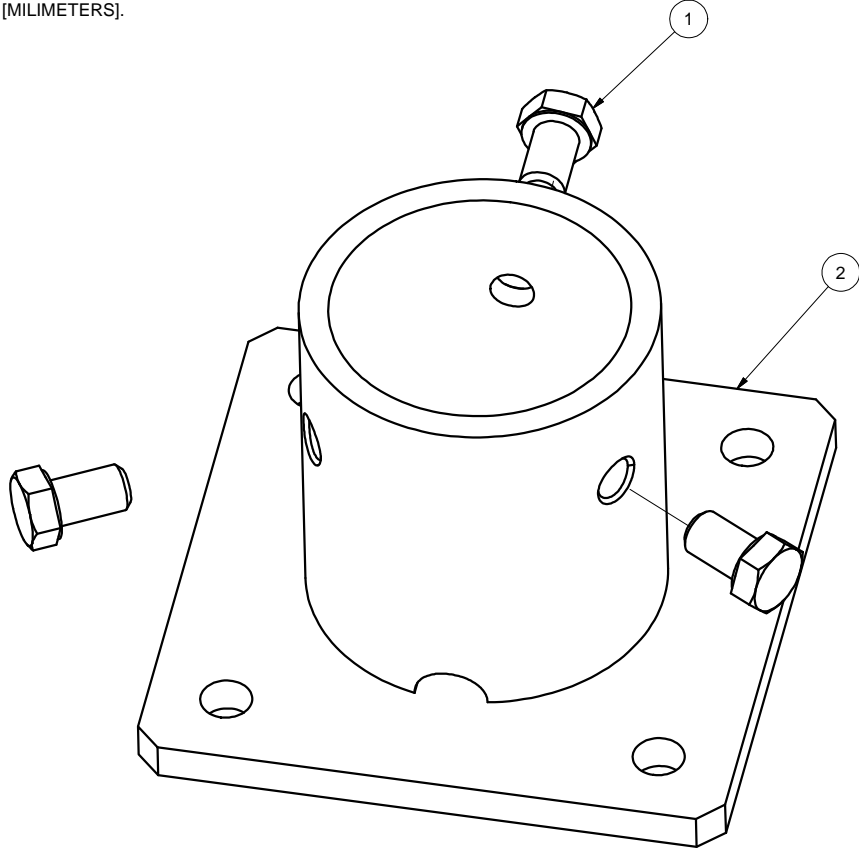

REVISIONS			
REV	DESCRIPTION	BY	DATE
A	INITIAL RELEASE	LWF	10/20/2016

2	A21120-001	2" PIPE BASE	1
1	B15018-011	HEX CAP SCREW 3/8-16 X 5/8	3
ITEM	PART NUMBER	DESCRIPTION	QTY
MATERIAL		SEE NOTES	
Third Angle Projection:			
GENERAL SPECIFICATIONS		Sunmodo Corp. 1905 E 5TH STREET, STE A, VANCOUVER, WA 98661	
Tolerances		TITLE	
X.XXX ±0.01 [0.25mm] X.XX ±0.02 [0.50mm] X.X ±0.039 [1.0mm] Unless otherwise spec'd		2" PIPE BASE KIT	
DRAWN BY		DATE	DRAWING NUMBER
LWF		10/20/2016	B K10268-001
CHECKED BY			
APPROVALS		SCALE:	SHEET 1 of 1
		NONE	

THIS DRAWING IS CONFIDENTIAL PROPERTY OF SUNMODO AND ITS CONTENTS MAY NOT BE DISCLOSED WITHOUT THE PRIOR WRITTEN CONSENT OF SUNMODO CORP.

NOTES: UNLESS OTHERWISE SPECIFIED

1. DIMENSIONS SHOWN ARE INCHES [MILIMETERS].
2. MATERAIL: ALUMINUM 6005-T5.
FINISH: CLEAR ANODIZED 10 μ m THICK.
3. THE UNSPECIFIED DIMENSIONS ARE SPECIFIED BY 2D CAD FILE.

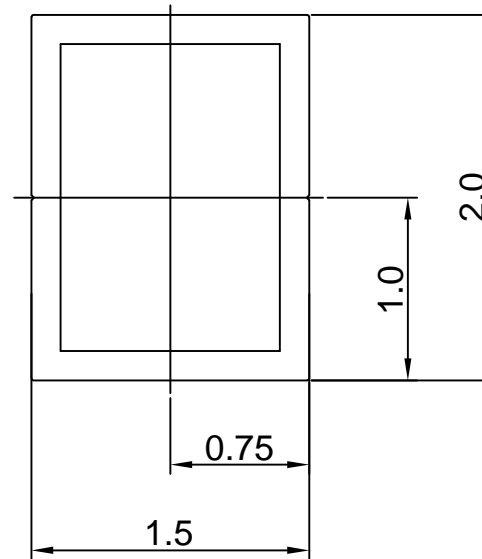

Section properties:

Weight: 1.156 lbs/ft

Area: 0.992 in²

Perimeter: 12.601 in

Bounding Box: X: -1.000,1.000

Y: -0.750, 0.750

Centroid:(0.000,0.000)

Moments of Inertia(in⁴): I_x=0.506,I_y=0.322

Section modulus in bending(in³): W_x=0.675,W_y=0.322

Radii of Gyration: X: 0.714, Y: 0.570

MATERIAL		SEE NOTES	
Third Angle Projection:			
GENERAL SPECIFICATIONS			
All Dimensions in inches [millimeters]			
Tolerances			
X.XXX ± 0.01 [0.25mm]		Break all sharp edges	
X.XX ± 0.02 [0.50mm]		.010-.020 unless	
X.X ± 0.039 [1.0mm]		otherwise specified.	
Unless otherwise specd			
DRAWN BY	DATE	TITLE	
zcg	03/12/2014	1905 E 5TH STREET, SUITE A, VANCOUVER, WA 98661	
CHECKED BY		B	DRAWING NUMBER
			A20164
APPROVALS		SCALE:	SHEET 1 of 1
		NONE	

Sunmodo Corp.

1905 E 5TH STREET, SUITE A, VANCOUVER, WA 98661

TITLE
1.5X2 AL TUBE BRACE EXTRUSION

DRAWING NUMBER
A20164

SCALE: NONE SHEET 1 of 1

REVISIONS			
REV	DESCRIPTION	BY	DATE
A	ADDED BOTTOM CHANNEL & CHANGED ONE 3/8 CHANNEL TO 1/4	zcg	02/21/2013

NOTES: UNLESS OTHERWISE SPECIFIED

1. DIMENSIONS SHOWN ARE INCHES [MILIMETERS].
2. MATERAIL: ALUMINUM 6005-T5.
FINISH: CLEAR ANODIZED 15 μ m THICK.
3. THE UNSPECIFIED DIMENSIONS ARE SPECIFIED BY 2D CAD FILE.

2X 1/4 BOLT SLOT

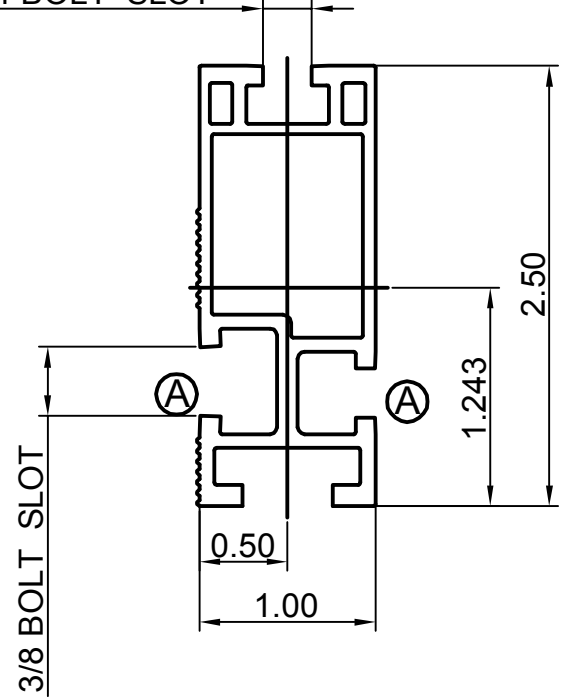

Section properties:

Weight: 0.850 lbs/ft
 Area: 0.723 in²
 Perimeter: 17.325 in
 Bounding Box: X: -0.500,0.500
 Y: -1.243,1.257

Centroid:(0.000,0.000)
 Moments of Inertia(in⁴): I_x=0.486,I_y=0.095
 Section modulus in bending(in³): W_x=0.387,W_y=0.190
 Radii of Gyration: X: 0.820, Y: 0.363

MATERIAL SEE NOTES		Sunmodo Corp.	
Third Angle Projection:			
GENERAL SPECIFICATIONS All Dimensions in inches [millimeters]		1905 E 5TH STREET, SUITE A, VANCOUVER, WA 98661	
Tolerances: X.XXX ± 0.01 [0.25mm] X.XX ± 0.02 [0.50mm] X.X ± 0.039 [1.0mm] Unless otherwise spec'd		TITLE HELIO STANDARD RAIL	
DRAWN BY zcg	DATE 02/21/2013	DRAWING NUMBER A20144	
CHECKED BY		SCALE: NONE SHEET 1 of 1	
APPROVALS			

NOTES: UNLESS OTHERWISE SPECIFIED

1. DIMENSIONS SHOWN ARE INCHES [MILIMETERS].
2. MATERIAL: 6005-T5.
FINISH: CLEAR ANODIZED 10um THICK.
3. THE UNSPECIFIED RADII ARE .02" MAX.
4. THE UNSPECIFIED DIMENSIONS ARE SPECIFIED BY 2D CAD FILE.

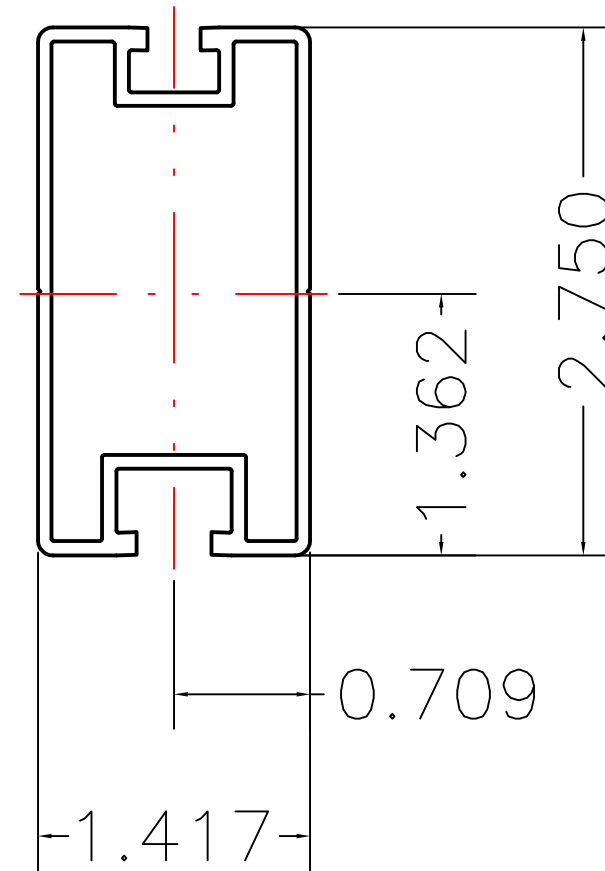

Section properties:

Weight: 0.862 lbs/ft
 Area: 0.736 in²
 Perimeter: 19.824 in
 Bounding Box: X: -0.709,0.709
 Y: -1.362,1.388
 Centroid:(0.000,0.000)
 Moments of Inertia(in⁴): I_x=0.727,I_y=0.214
 Section modulus in bending(in³): W_x=0.524,W_y=0.302
 Radii of Gyration: X: 0.994, Y: 0.539

MATERIAL SEE NOTES	
Third Angle Projection:	
GENERAL SPECIFICATIONS All Dimensions in inches [millimeters]	
Tolerances	
X.XXX ±0.01 [0.25mm]	Break all sharp edges
X.XX ±0.02 [0.50mm]	.010-.020 unless
X.X ±0.039 [1.0mm]	otherwise specified.
Unless otherwise spec'd	
DRAWN BY KYY	DATE 01/18/2018
CHECKED BY	
APPROVALS	

SunModo Corp.	
14800 NE 65TH STREET, VANCOUVER WA 98682	
TITLE RAIL, HR300 (SUNRAY), EXTRUSION	
B	DRAWING NUMBER A20288
SCALE: NONE	SHEET 1 of 1

THIS DRAWING IS CONFIDENTIAL PROPERTY OF SUNMODO AND ITS CONTENTS MAY NOT BE DISCLOSED WITHOUT THE PRIOR WRITTEN CONSENT OF SUNMODO CORP.

REV	DESCRIPTON	BY	DATE
A	0.44 WAS 0.41, 0.44 WAS 0.33	LWF	11/30/2015

NOTES: UNLESS OTHERWISE SPECIFIED

- 1. DIMENSIONS SHOWN ARE INCHES [MILIMETERS].
- 2. MATERIAL: ALUMINUM 6005-T5.
FINISH: CLEAR ANODIZED 15 μm THICK.
- 3. THE UNSPECIFIED DIMENSIONS ARE SPECIFIED BY 2D CAD FILE.

2X 1/4 BOLT SLOT

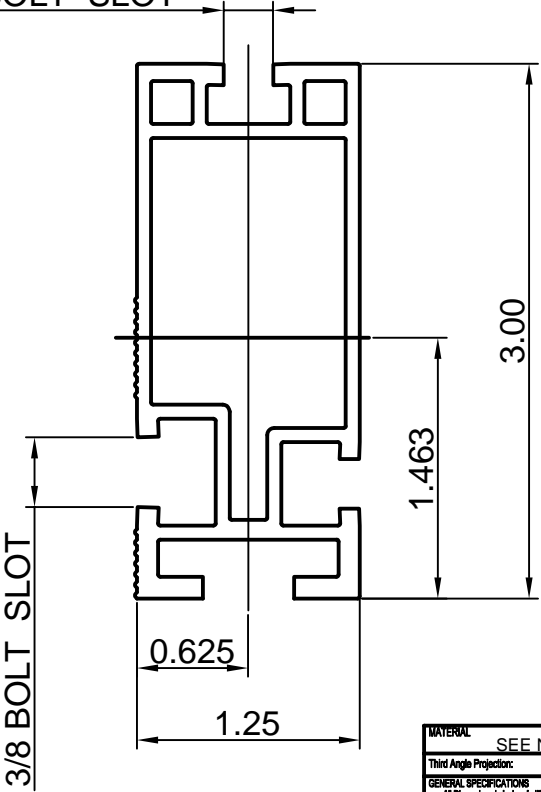

Section properties:

Weight: 1.151 lbs/ft
 Area: 0.980 in²
 Perimeter: 22.104 in
 Bounding Box: X: -0.625,0.625
 Y: -1.463,1.537
 Centroid:(0.000,0.000)
 Moments of Inertia(in⁴): Ix=1.047,Iy=0.207
 Section modulus in bending(in³): Wx=0.681,Wy=0.331
 Radii of Gyration: X: 1.034, Y: 0.460

MATERIAL		SEE NOTES	
Third Angle Projection			
GENERAL SPECIFICATIONS			
All Dimensions in Inches [millimeters]			
Tolerances			
XXX ±0.01 (0.25mm)			
XX ±0.02 (0.50mm)			
X ±0.03 (1.0mm)			
Unless otherwise specified.			
DRAWN BY		DATE	
ZCJ		02/21/2013	
CHECKED BY		DATE	
APPROVALS		DATE	
Sunmodo Corp.		1905 E 5TH STREET, SUITE A, VANCOUVER, WA 98661	
TITLE		HELIO HEAVY RAIL	
DRAWING NUMBER		A20145	
SCALE: NONE		SHEET 1 of 1	

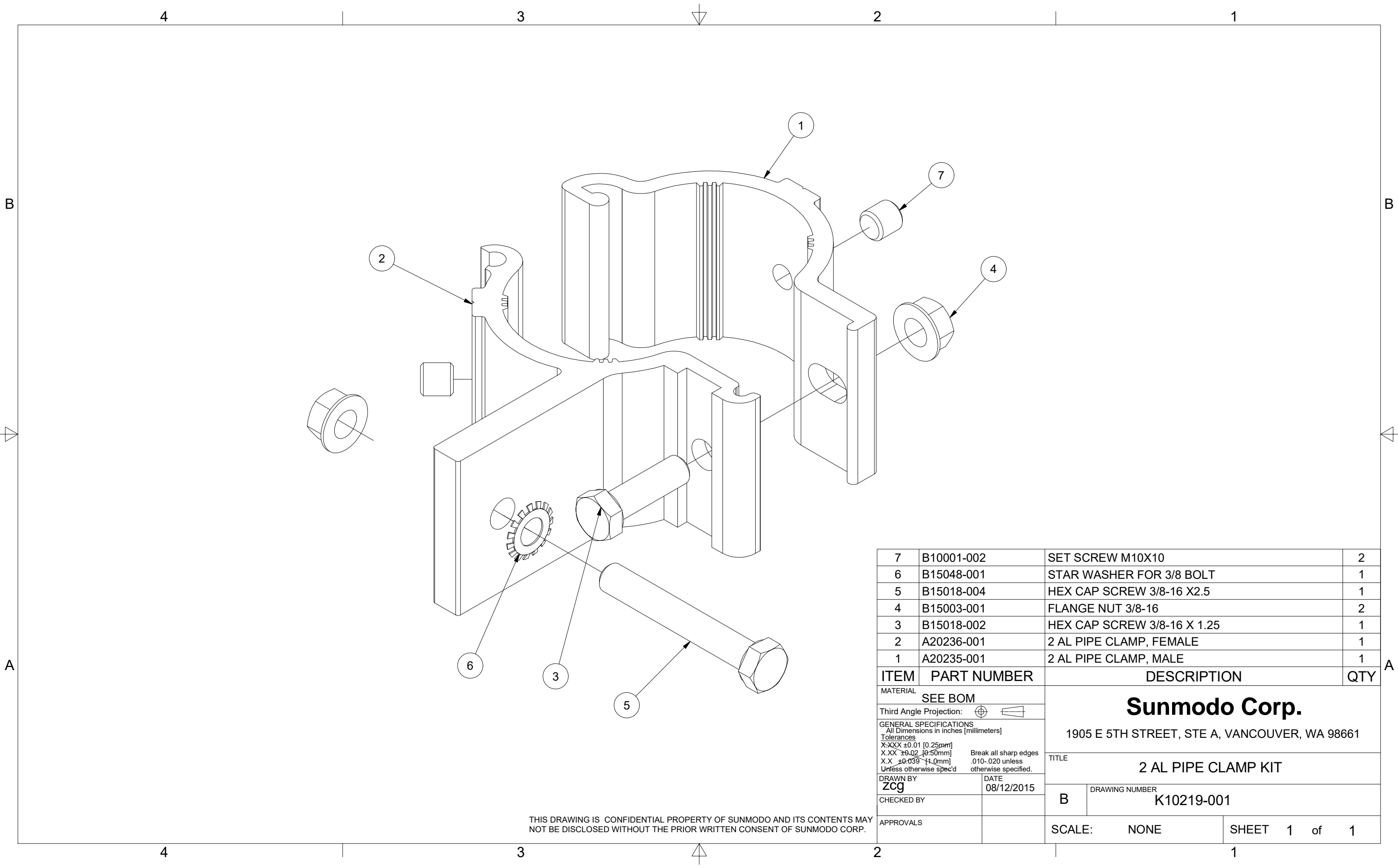

7	B10001-002	SET SCREW M10X10	2
6	B15048-001	STAR WASHER FOR 3/8 BOLT	1
5	B15018-004	HEX CAP SCREW 3/8-16 X2.5	1
4	B15003-001	FLANGE NUT 3/8-16	2
3	B15018-002	HEX CAP SCREW 3/8-16 X 1.25	1
2	A20236-001	2 AL PIPE CLAMP, FEMALE	1
1	A20235-001	2 AL PIPE CLAMP, MALE	1

ITEM	PART NUMBER	DESCRIPTION	QTY
MATERIAL		SEE BOM	
Third Angle Projection:			
GENERAL SPECIFICATIONS		All Dimensions in inches (millimeters)	
Tolerances		X-XXX ±0.01 [0.25mm]	
X-XX ±0.02 [0.50mm]		Break all sharp edges	
X-X ±0.039 [1.0mm]		.010-.020 unless otherwise specified.	
Unless otherwise spec'd			
DRAWN BY	DATE	Sunmodo Corp. 1905 E 5TH STREET, STE A, VANCOUVER, WA 98661	
zcg	08/12/2015		
CHECKED BY		TITLE	
		2 AL PIPE CLAMP KIT	
APPROVALS		DRAWING NUMBER	
		B	K10219-001
		SCALE:	NONE
		SHEET	1 of 1

THIS DRAWING IS CONFIDENTIAL PROPERTY OF SUNMODO AND ITS CONTENTS MAY NOT BE DISCLOSED WITHOUT THE PRIOR WRITTEN CONSENT OF SUNMODO CORP.

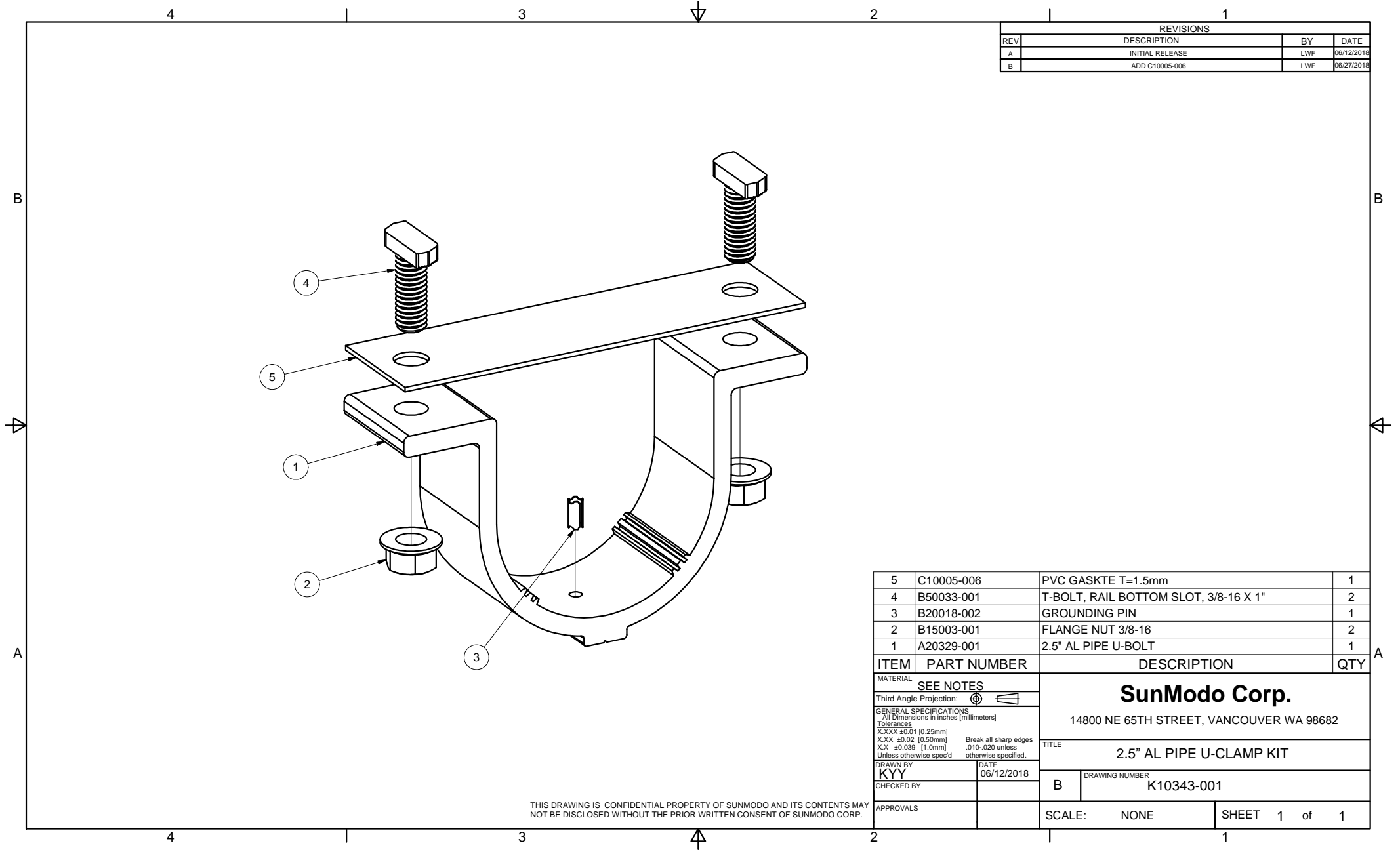

REVISIONS			
REV	DESCRIPTION	BY	DATE
A	INITIAL RELEASE	LWF	06/12/2018
B	ADD C10005-006	LWF	06/27/2018

ITEM	PART NUMBER	DESCRIPTION	QTY
5	C10005-006	PVC GASKTE T=1.5mm	1
4	B50033-001	T-BOLT, RAIL BOTTOM SLOT, 3/8-16 X 1"	2
3	B20018-002	GROUNDING PIN	1
2	B15003-001	FLANGE NUT 3/8-16	2
1	A20329-001	2.5" AL PIPE U-BOLT	1

MATERIAL		SEE NOTES	
Third Angle Projection:			
GENERAL SPECIFICATIONS		<p>SunModo Corp. 14800 NE 65TH STREET, VANCOUVER WA 98682</p>	
All Dimensions in inches [millimeters] Tolerances X.XXX ±0.01 [0.25mm] X.XX ±0.02 [0.50mm] X.X ±0.039 [1.0mm] Unless otherwise spec'd			
TITLE		2.5" AL PIPE U-CLAMP KIT	
DRAWN BY	DATE	DRAWING NUMBER	
KYY	06/12/2018	B K10343-001	
CHECKED BY			
APPROVALS		SCALE: NONE	SHEET 1 of 1

THIS DRAWING IS CONFIDENTIAL PROPERTY OF SUNMODO AND ITS CONTENTS MAY NOT BE DISCLOSED WITHOUT THE PRIOR WRITTEN CONSENT OF SUNMODO CORP.

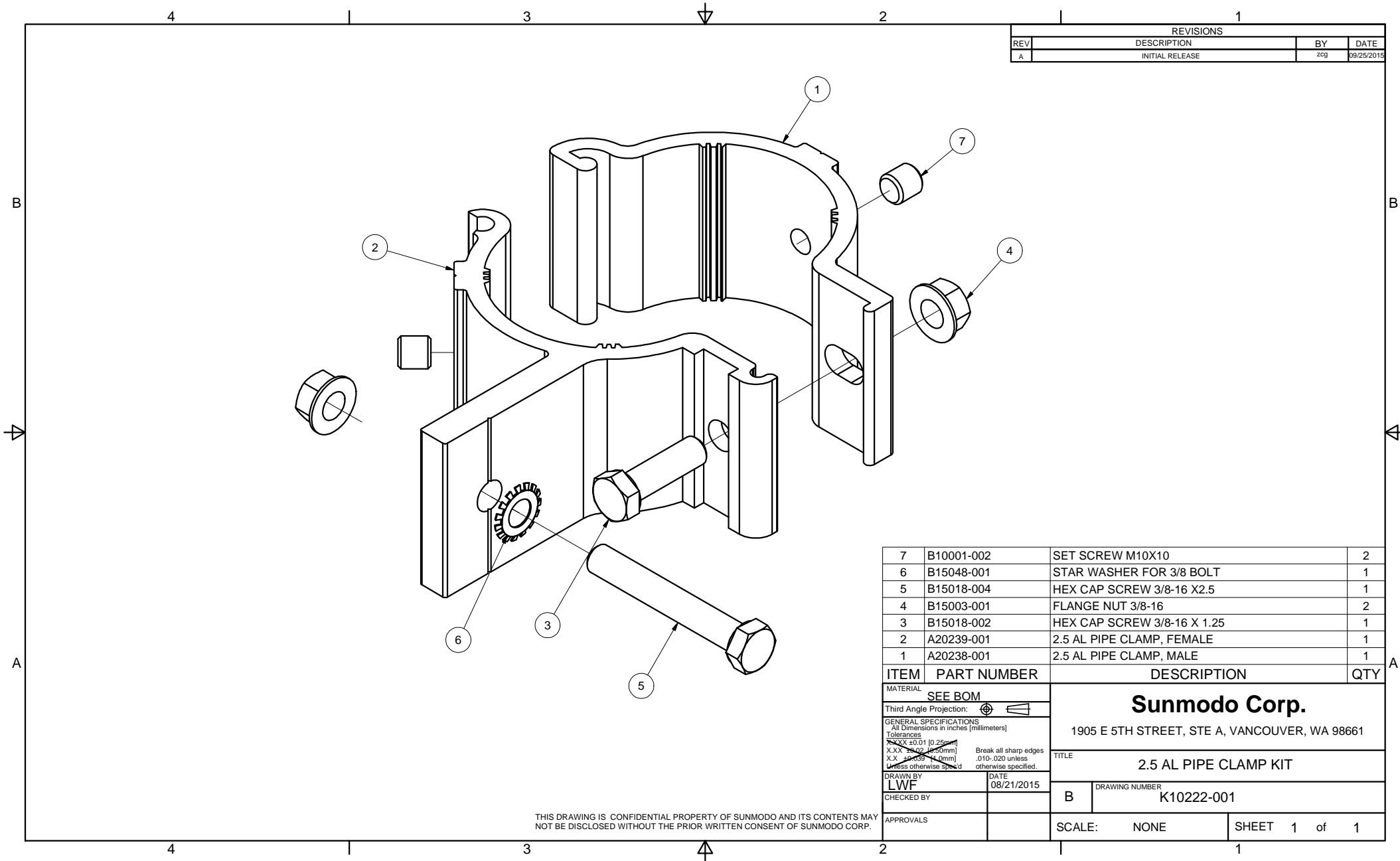

REVISIONS			
REV	DESCRIPTION	BY	DATE
A	INITIAL RELEASE	zcg	09/25/2015

ITEM	PART NUMBER	DESCRIPTION	QTY
7	B10001-002	SET SCREW M10X10	2
6	B15048-001	STAR WASHER FOR 3/8 BOLT	1
5	B15018-004	HEX CAP SCREW 3/8-16 X2.5	1
4	B15003-001	FLANGE NUT 3/8-16	2
3	B15018-002	HEX CAP SCREW 3/8-16 X 1.25	1
2	A20239-001	2.5 AL PIPE CLAMP, FEMALE	1
1	A20238-001	2.5 AL PIPE CLAMP, MALE	1

MATERIAL		SEE BOM	
Third Angle Projection:			
GENERAL SPECIFICATIONS All Dimensions in inches [millimeters] Tolerances X.XX ±0.01 [0.25mm] X.XX ±0.02 [0.50mm] X.X ±0.03 [0.75mm] Unless otherwise specified, Break all sharp edges .010-.020 unless otherwise specified.			
DRAWN BY	DATE	TITLE	
LWF	08/21/2015	2.5 AL PIPE CLAMP KIT	
CHECKED BY		DRAWING NUMBER	
		B	K10222-001
APPROVALS		SCALE:	NONE
		SHEET	1 of 1

THIS DRAWING IS CONFIDENTIAL PROPERTY OF SUNMODO AND ITS CONTENTS MAY NOT BE DISCLOSED WITHOUT THE PRIOR WRITTEN CONSENT OF SUNMODO CORP.

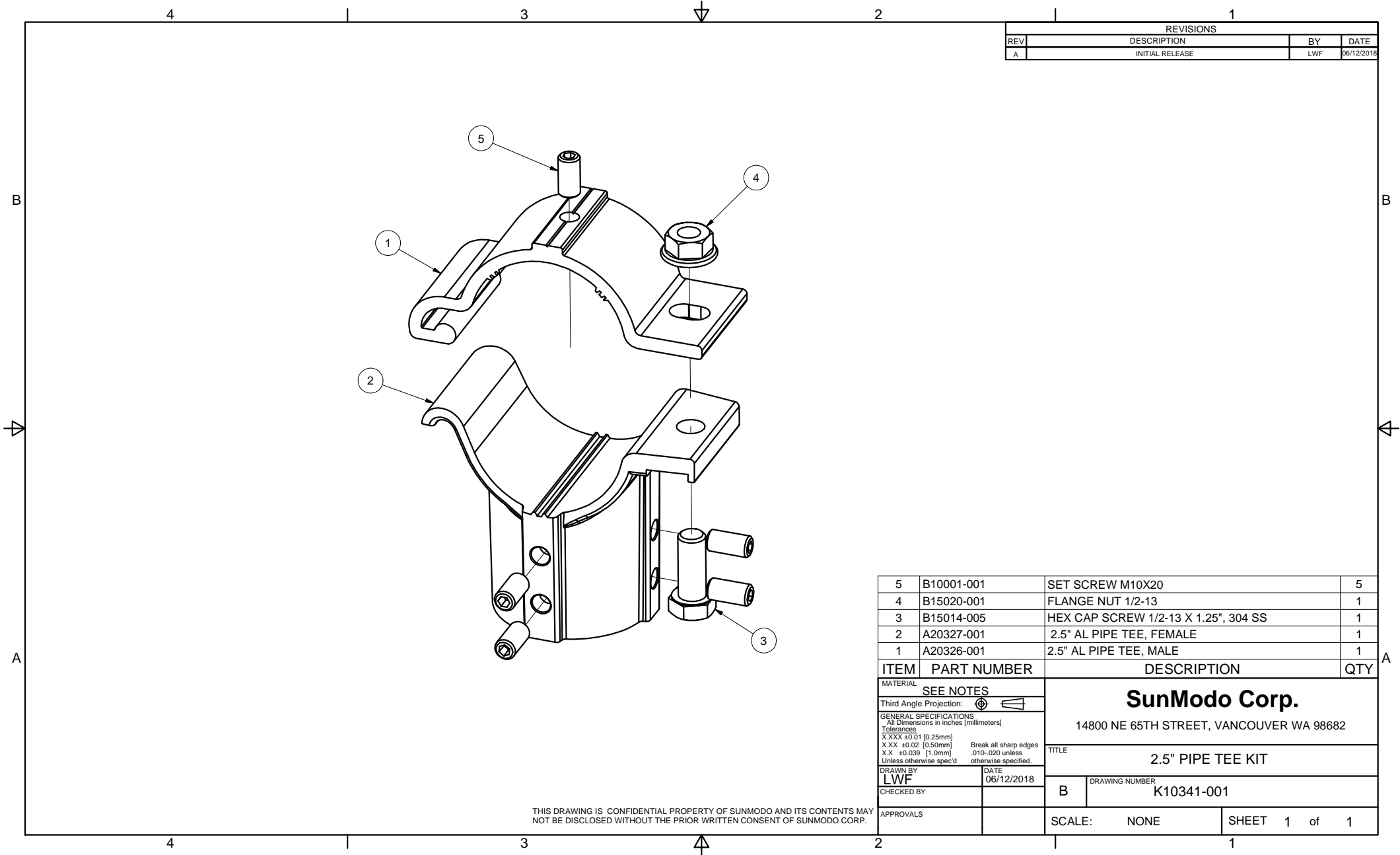

REVISIONS			
REV	DESCRIPTION	BY	DATE
A	INITIAL RELEASE	LWF	06/12/2018

5	B10001-001	SET SCREW M10X20	5
4	B15020-001	FLANGE NUT 1/2-13	1
3	B15014-005	HEX CAP SCREW 1/2-13 X 1.25", 304 SS	1
2	A20327-001	2.5" AL PIPE TEE, FEMALE	1
1	A20326-001	2.5" AL PIPE TEE, MALE	1
ITEM	PART NUMBER	DESCRIPTION	QTY

MATERIAL		SEE NOTES	
Third Angle Projection:			
GENERAL SPECIFICATIONS		<p>SunModo Corp. 14800 NE 65TH STREET, VANCOUVER WA 98682</p>	
All Dimensions in inches [millimeters] Tolerances X.XXX ±0.01 [0.25mm] X.XX ±0.02 [0.50mm] X.X ±0.039 [1.0mm] Unless otherwise spec'd			
TITLE		2.5" PIPE TEE KIT	
DRAWN BY	DATE	DRAWING NUMBER	
LWF	06/12/2018	B K10341-001	
CHECKED BY			
APPROVALS		SCALE: NONE	SHEET 1 of 1

THIS DRAWING IS CONFIDENTIAL PROPERTY OF SUNMODO AND ITS CONTENTS MAY NOT BE DISCLOSED WITHOUT THE PRIOR WRITTEN CONSENT OF SUNMODO CORP.

REVISIONS			
REV	DESCRIPTION	BY	DATE
A	INITIAL RELEASE	LWF	06/12/2018

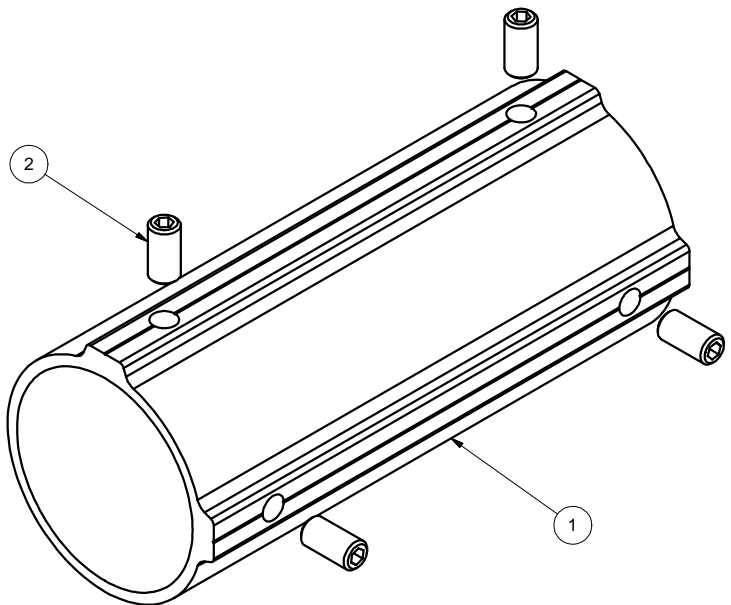

2	B10001-001	SET SCREW M10X20	4
1	A20328-001	2.5" PIPE SPLICE	1
ITEM	PART NUMBER	DESCRIPTION	QTY
MATERIAL		SEE NOTES	
Third Angle Projection:			
GENERAL SPECIFICATIONS		SunModo Corp. 14800 NE 65TH STREET, VANCOUVER WA 98682	
All Dimensions in inches [millimeters] Tolerances X.XXX ±0.01 [0.25mm] X.XX ±0.02 [0.50mm] X.X ±0.039 [1.0mm] Unless otherwise spec'd		Break all sharp edges .010-.020 unless otherwise specified.	
DRAWN BY		TITLE	
LWF		2.5" PIPE SPLICE KIT	
CHECKED BY		DRAWING NUMBER	
		B K10342-001	
APPROVALS		SCALE: NONE SHEET 1 of 1	

THIS DRAWING IS CONFIDENTIAL PROPERTY OF SUNMODO AND ITS CONTENTS MAY NOT BE DISCLOSED WITHOUT THE PRIOR WRITTEN CONSENT OF SUNMODO CORP.

NOTES: UNLESS OTHERWISE SPECIFIED

1. DIMENSIONS SHOWN ARE INCHES [MILIMETERS].
2. MATERIAL:HIGH STRENGTH STEEL PIPE OR TUBE.
3. FINISH: HOT DIP GALVANIZE PER ASTM A123 / A123M - 02.

MINIMUM 50 KSI YIELD STRESS.

4. BREAK ALL BURRS AND SHARP EDGES.

5. ALL WELDING MUST BE IN COMPLIANCE WITH AWS CODE D1;1.

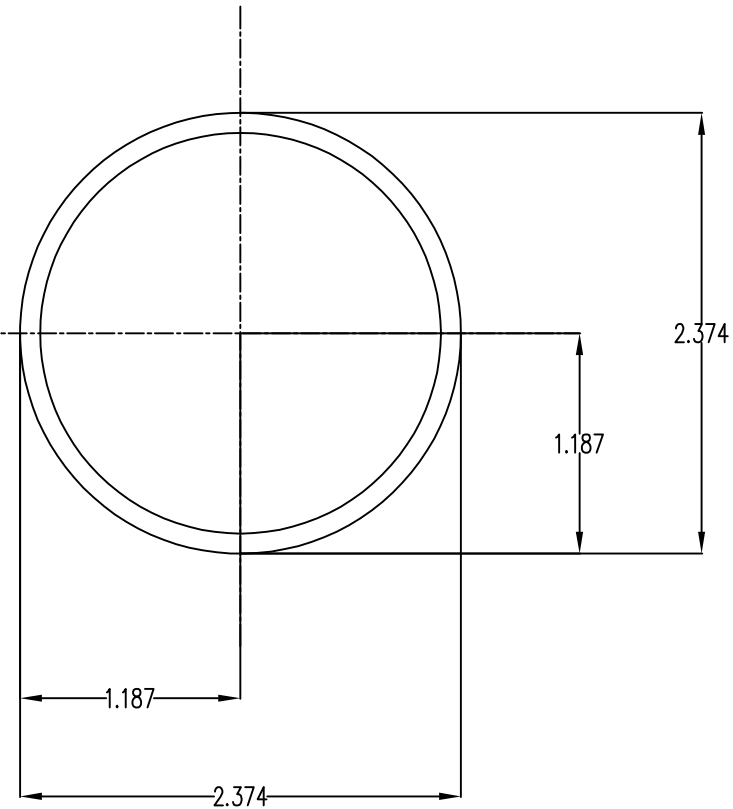

Section properties:

Weight: 2.641 lbs/ft

Area: 0.776 in²

Perimeter: 14.238 in

Bounding Box: X: -1.187,1.187

Y: -1.187,1.187

Centroid:(0.000,0.000)

Moments of Inertia(in⁴): Ix=0.499,Iy=0.499

Section modulus in bending(in³): Wx=0.420,Wy=0.420

Radii of Gyration: X: 0.802, Y: 0.802

MATERIAL		SEE NOTES		Sunmodo Corp. 14800 NE 85TH STREET, VANCOUVER WA 98682	
Third Angle Projection:					
GENERAL SPECIFICATIONS				TITLE	
All Dimensions in Inches (millimeters)				PIPE, HSS, 2.375" OD X 12 GAUGE,L=XXX	
Tolerances				Break all sharp edges .010-.020 unless otherwise specified.	
XXX ±0.01 (0.25mm)					
XX ±0.02 (0.50mm)					
X ±0.050 (1.27mm)					
Unless otherwise specified					
DRAWN BY	DATE	B		DRAWING NUMBER	
LWF	04/03/2019			A21165	
CHECKED BY					
APPROVALS				SCALE:	NONE
				SHEET	1 of 1

NOTES: UNLESS OTHERWISE SPECIFIED

1. DIMENSIONS SHOWN ARE INCHES [MILIMETERS].
2. MATERAIL:HIGH STRENGTH STEEL PIPE OR TUBE.
3. FINISH: HOT DIP GALVANIZE PER ASTM A123 / A123M - 02.

MINIMUM 50 KSI YIELD STRESS.

4. BREAK ALL BURRS AND SHARP EDGES.
5. ALL WELDING MUST BE IN COMPLIANCE WITH AWS CODE D1;1.

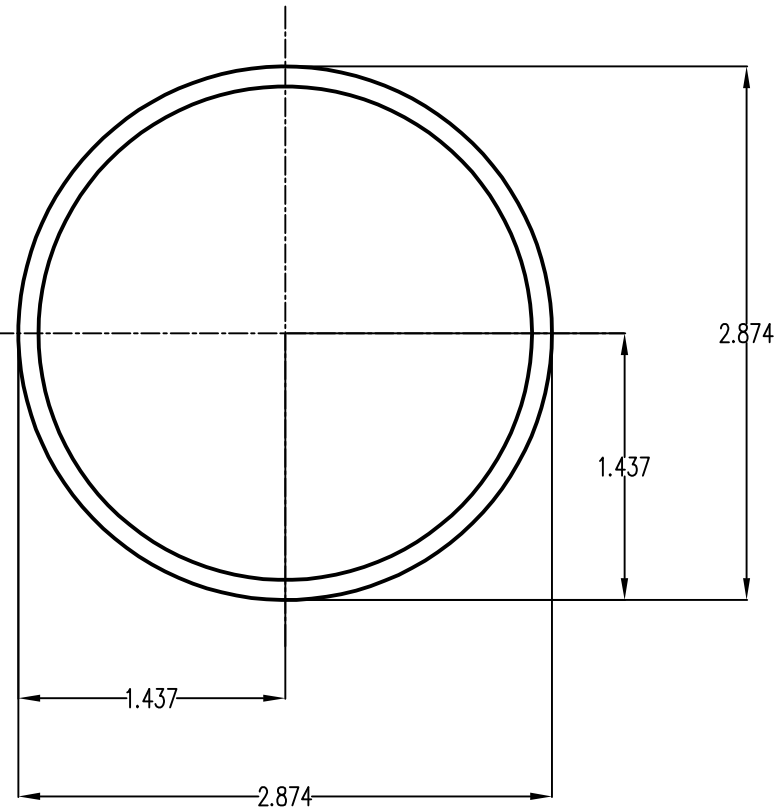

Section properties:

Weight: 3.201 lbs/ft

Area: 0.941 in²

Perimeter: 17.378 in

Bounding Box: X: -1.437,1.437

Y: -1.437,1.437

Centroid:(0.000,0.000)

Moments of Inertia(in⁴): Ix=0.901,Iy=0.901

Section modulus in bending(in³): Wx=0.627,Wy=0.627

Radii of Gyration: X: 0.979, Y: 0.979

MATERIAL		SEE NOTES		Sunmodo Corp.	
Third Angle Projection:					
GENERAL SPECIFICATIONS				14800 NE 85TH STREET, VANCOUVER WA 98682	
All Dimensions in Inches (millimeters)				TITLE	
Tolerances				PIPE, HSS, 2.875" OD X 12 GAUGE,L=XXX	
XXX ±0.01 (0.25mm)				Break all sharp edges .010-.020 unless otherwise specified.	
XX ±0.02 (0.50mm)				DRAWING NUMBER	
X ±0.050 (1.2mm)				B A21168	
Unless otherwise specified				APPROVALS	
DRAWN BY		DATE		SCALE: NONE	
LWF		04/03/2019		SHEET 1 of 1	
CHECKED BY					