



Project Number: U2716-092-191

April 12, 2021

Sunmodo
14800 NE 65th Street
Vancouver, WA 98682

**REFERENCE: Sunmodo Sunturf Ground Mount A2 (85x45)
Ground Mount PV Array Installation**

To Whom It May Concern:

Per request of Sunmodo, we have been asked to prepare the structural design of a ground-mounted PV solar array system with several foundation options as shown in the attached calculations. The adopted building code in this jurisdiction is the New York City Building Code, 2014 Edition. Vector Structural Engineering requires that we review each site specific install, and we are not liable for installs at site specific locations we have not reviewed. The following design parameters are used in our analysis:

- Minimum Design Loads for Buildings and Other Structures (ASCE 7-05)
- Design wind speed for occupancy category I structures: 115 mph
- Wind Importance Factor: 0.77
- Wind exposure: C
- Ground snow load: 30 psf
- The ground screws and helical piers must be tested to 1.5 times uplift and 2.0 times lateral reactions found in the table below. A minimum of one ground screw or helical pier must be tested.

Load (ASD)	Value (lbs)	Factor of Safety	Test Value (lbs)
UPLIFT	2385	1.5	3578
LATERAL	1665	2	3330

Foundation concrete shall have a minimum compressive strength of 2500 psi at 28 days. Cement for all concrete shall be Type I or II with a minimum of 6% entrained air with a water/cement ratio of 0.50. Maximum aggregate size shall be 3/4". No special inspection of concrete strength is required.

Footings are designed based on an allowable soil bearing pressure of 1500 psf an allowable skin friction of 250 psf, an allowable lateral bearing pressure of 150 pcf, and a coefficient of friction of 0.3. Vector Structural Engineering strongly recommends independent soils testing be performed by a licensed geotechnical engineer to verify the assumed soil parameters.

All ground mounts are to be installed per manufacturer's recommendations. The use of solar panel support span tables provided by the manufacturer is allowed only where the site conditions and solar panel configuration match the description of the span tables. Electrical engineering is beyond our scope. All work performed must be in accordance with accepted industry-wide methods and applicable safety standards. Vector Structural Engineering assumes no responsibility for improper installation of the solar panels.

Very truly yours,

VECTOR STRUCTURAL ENGINEERING, LLC
Firm License: COA0012807

Wells Holmes, P.E.
License: 90187 - Expires: 09/30/2023
Project Engineer

Enclosures

WLH/stb



04/12/2021

**UNAUTHORIZED ALTERATIONS OR ADDITIONS
TO A DOCUMENT BEARING A LICENSED
PROFESSIONAL ENGINEER'S SEAL IS A
VIOLATION OF SECTION 7209(2) OF THE N.Y.
STATE EDUCATION LAW**



JOB NO. U2716-092-191
 PROJECT SUNMODO SUNTURF GROUND MOUNTS A2
 SUBJECT ALL OPTIONS

651 W GALENA PARK BLVD. #101 (801) 990-1775
 DRAPER, UTAH 84020 (801) 990-1776 FAX

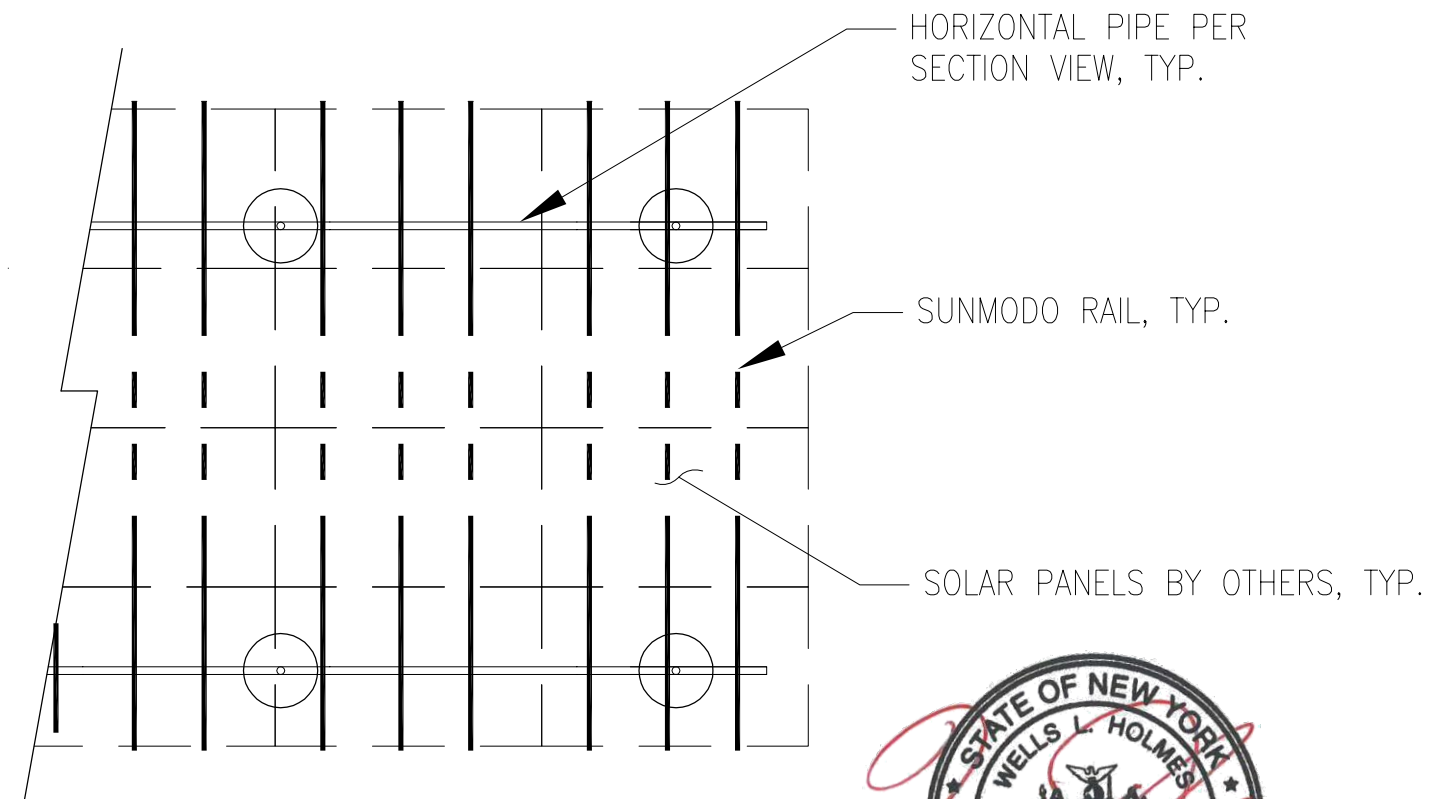
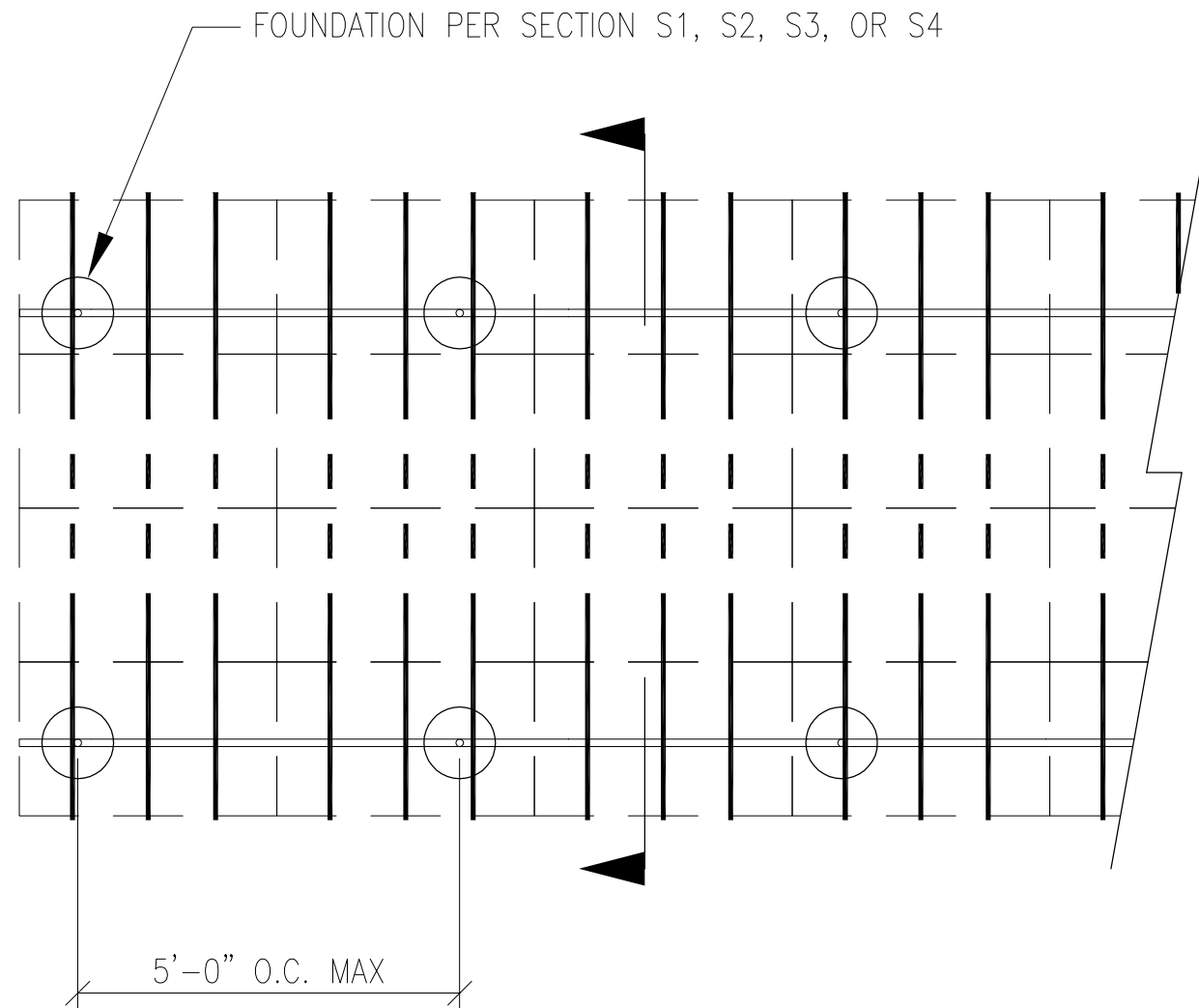

UNAUTHORIZED ALTERATIONS OR ADDITIONS
 TO A DOCUMENT BEARING A LICENSED
 PROFESSIONAL ENGINEER'S SEAL IS A
 VIOLATION OF SECTION 7209(2) OF THE N.Y.
 STATE EDUCATION LAW



04/12/2021

PV ARRAY PLAN

N.T.S.

P1

PROJECT SUNMODO SUNTURF GROUND MOUNTS A2

SUBJECT DRILLED PIER OPTION

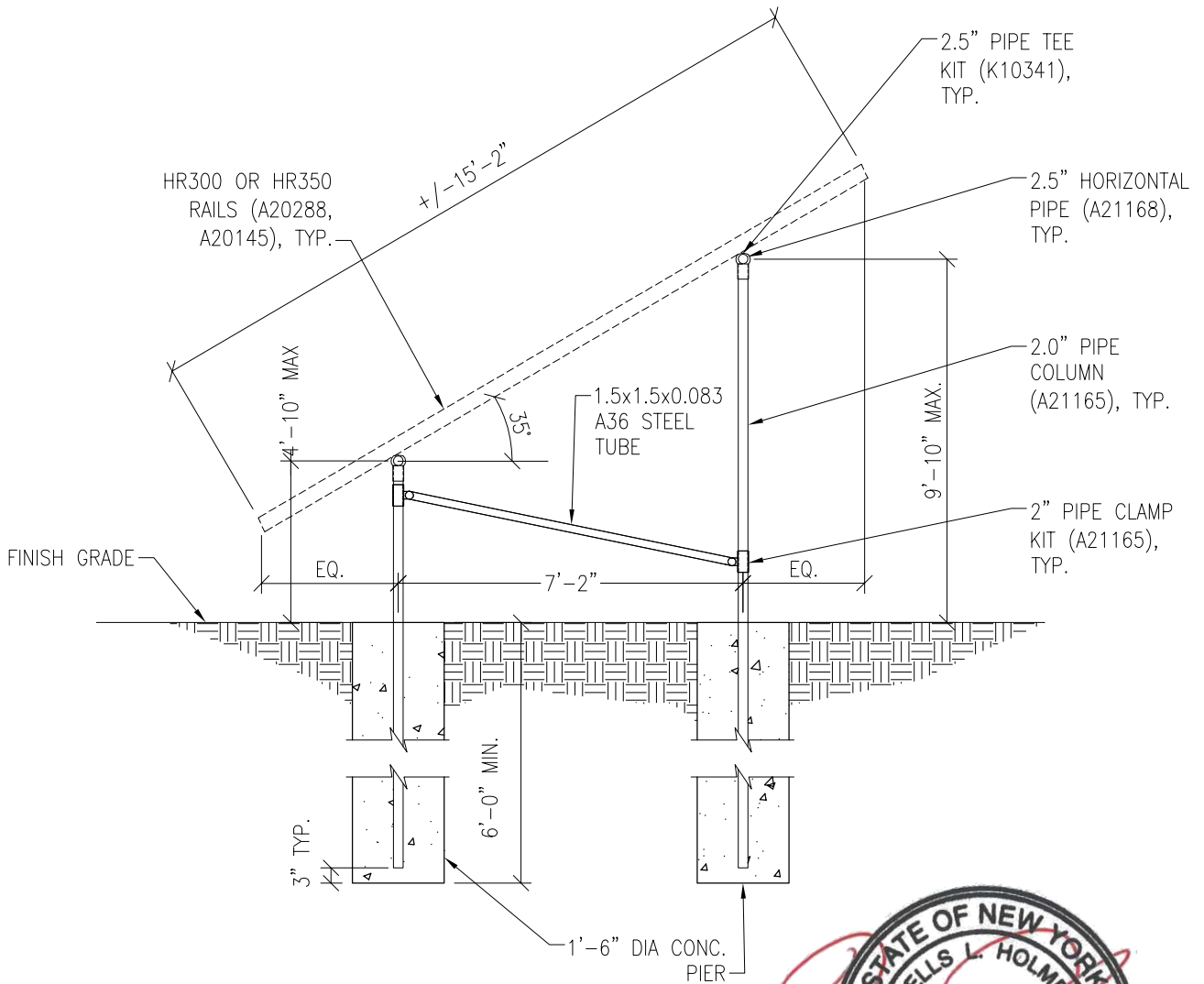

**UNAUTHORIZED ALTERATIONS OR ADDITIONS
TO A DOCUMENT BEARING A LICENSED
PROFESSIONAL ENGINEER'S SEAL IS A
VIOLATION OF SECTION 7209(2) OF THE N.Y.
STATE EDUCATION LAW**



04/12/2021

PV ARRAY SECTION

N.T.S.

S1

Vector Engineers requires that we review each site specific install and is not liable for installs at site specific locations we have not reviewed.

PROJECT SUNMODO SUNTURF GROUND MOUNTS A2

SUBJECT HELICAL PIER OPTION

NOTES:

1. For ground mount components see Section S1.
2. A minimum of (1) helical pier must be load-tested as follows:
 - 2.1. Safety factor for uplift = 1.5,
 - 2.2. Safety factor for lateral loads = 2.0
 - 2.3. Upward deflection limit = 1/2"
 - 2.4. Lateral deflection limit = 1"
 - 2.5. The load tests must be performed by an approved contractor.

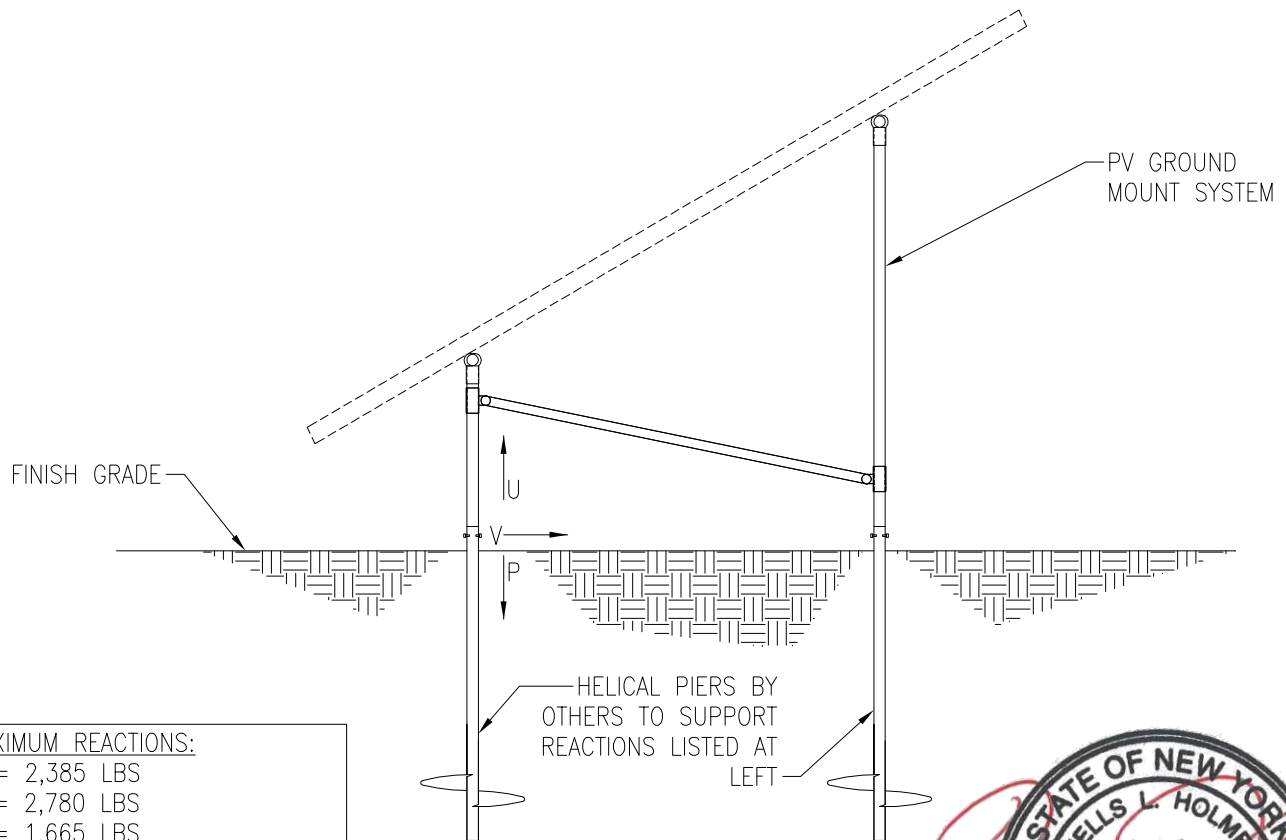

MAXIMUM REACTIONS:
 U = 2,385 LBS
 P = 2,780 LBS
 V = 1,665 LBS

**UNAUTHORIZED ALTERATIONS OR ADDITIONS
 TO A DOCUMENT BEARING A LICENSED
 PROFESSIONAL ENGINEER'S SEAL IS A
 VIOLATION OF SECTION 7209(2) OF THE N.Y.
 STATE EDUCATION LAW**



Vector Engineers requires that we review each site specific install and is not liable for installs at site specific locations we have not reviewed.

PV ARRAY SECTION

04/12/2021

N.T.S.

S2



JOB NO. U2716-092-191

PROJECT SUNMODO SUNTURF GROUND MOUNTS A2

SUBJECT GROUND SCREW OPTION

NOTES:

- 1. For ground mount components see Section S1.
- 2. A minimum of (1) ground screw must be load-tested as follows:
 - 2.1. Safety factor for uplift = 1.5,
 - 2.2. Safety factor for lateral loads = 2.0
 - 2.3. Upward deflection limit = 1/2"
 - 2.4. Lateral deflection limit = 1"
 - 2.5. The load tests must be performed by an approved contractor.

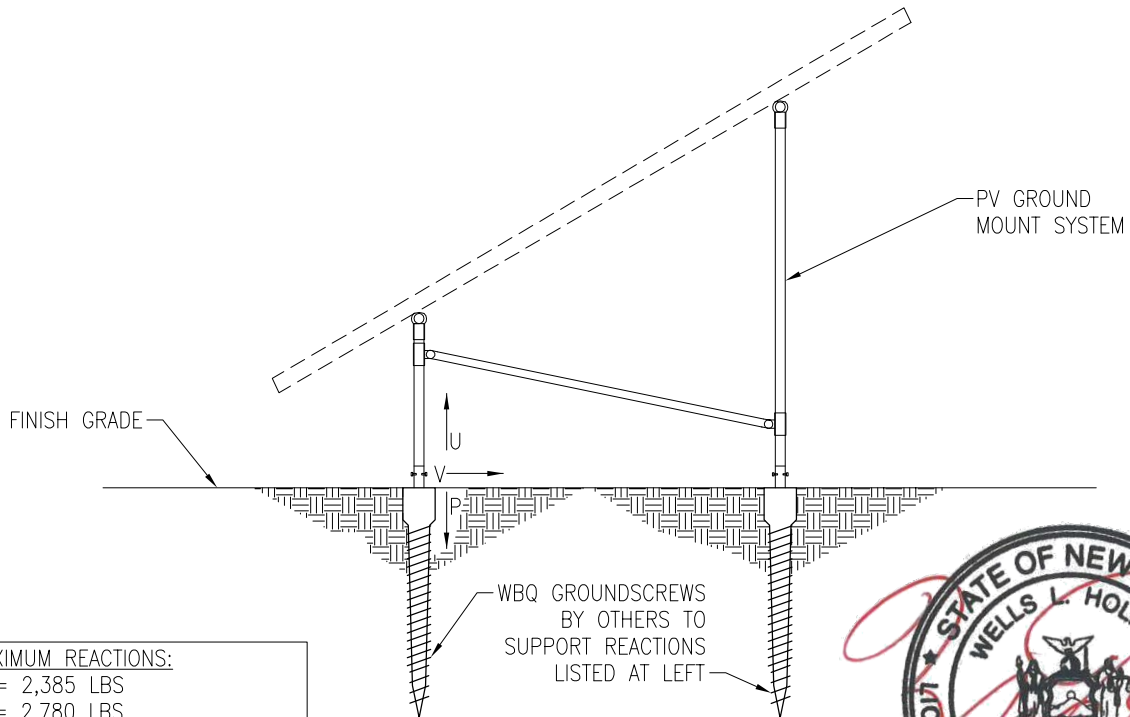

MAXIMUM REACTIONS:
 U = 2,385 LBS
 P = 2,780 LBS
 V = 1,665 LBS

UNAUTHORIZED ALTERATIONS OR ADDITIONS TO A DOCUMENT BEARING A LICENSED PROFESSIONAL ENGINEER'S SEAL IS A VIOLATION OF SECTION 7209(2) OF THE N.Y. STATE EDUCATION LAW



Vector Engineers requires that we review each site specific install and is not liable for installs at site specific locations we have not reviewed.

PV ARRAY SECTION

04/12/2021

N.T.S.

S3

651 W GALENA PARK BLVD. #101
 DRAPER, UTAH 84020

(801) 990-1775
 (801) 990-1776 FAX

WWW.VECTORSE.COM



JOB NO. U2716-092-191

PROJECT SUNMOD0 SUNTURF GROUND MOUNTS A2

SUBJECT BALLASTED BLOCK OPTION

NOTES:

- 1. For ground mount components see Section S1.

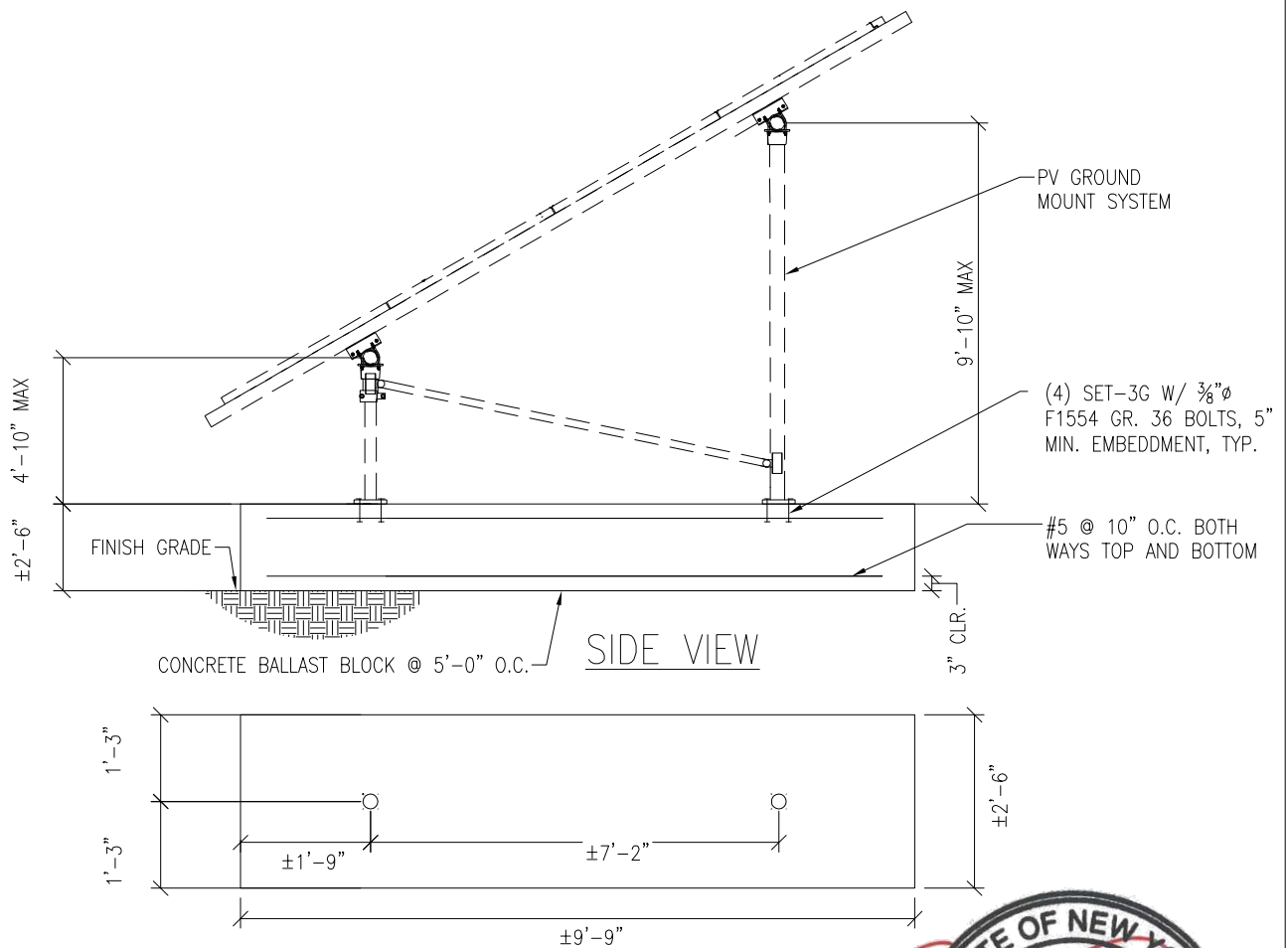

UNAUTHORIZED ALTERATIONS OR ADDITIONS TO A DOCUMENT BEARING A LICENSED PROFESSIONAL ENGINEER'S SEAL IS A VIOLATION OF SECTION 7209(2) OF THE N.Y. STATE EDUCATION LAW



Vector Engineers requires that we review each site specific install and is not liable for installs at site specific locations we have not reviewed.

PV ARRAY SECTION

N.T.S.

S4

651 W GALENA PARK BLVD. #101 DRAPER, UTAH 84020

(801) 990-1775 (801) 990-1776 FAX

04/12/2021

WWW.VECTORSE.COM



JOB NO.: U2716-091-191

DESIGNED: STB

DATE: 07/25/19

PROJECT: A2 – Sunmodo Sunturf GM

SUBJECT: Snow Load

SNOW LOAD (S):

ASCE 7 Standard:	05	
Panel Slope from Horizontal [°]:	35.0	
Snow Ground Load, p_g [psf]:	30.0	(Section 7.2)
Terrain Category:	C	(Table 7-2)
Exposure of Roof:	Fully Exposed	(Table 7-2)
Exposure Factor, C_e :	0.9	(Table 7-2)
Thermal Factor, C_t :	1.2	(Table 7-3)
Occupancy Category:	I	(Table 1-1)
Importance Factor, I_s :	0.8	(Table 7-4)
Flat Roof Snow Load, p_f [psf]:	18	(Equation 7-1)
Minimum Roof Snow Load, p_m [psf]:	0	(Section 7.3.4)
Unobstructed Slippery Surface?	Yes	(Section 7.4)
Slope Factor Figure:	Figure 7-2c	(Section 7.4)
Roof Slope Factor, C_s :	0.636	(Figure 7-2)
Sloped Roof Snow Load, p_s [psf]:	12	(Equation 7-2)
Design Snow Load, S [psf]:	12	
Tributary Transverse Length [ft]:	5.7	
Tributary Longitudinal Length [ft]:	6	
Tributary Area per Column [ft ²]:	34.0	
Snow Load per Column (1.0 S) [lb]:	392.5	



PROJECT: A2 – Sunmodo Sunturf GM

SUBJECT: Wind Pressure

Design Wind Load:

ASCE 7 Standard:	05	
Basic Wind Speed, V [mph]:	115	
Occupancy Category:	I	
Importance, I _w :	0.77	
Exposure Category	C	(Section 6.5.6.3)
Velocity Pressure Exposure Coefficient, K _z :	0.85	(Table 6-3)
Topographic Factor, K _{zt} :	1.0	(Section 6.5.7.2)
Wind Directionality Factor, K _d :	0.85	(Table 6-4)
Internal Pressure Coefficient, GC _{pi} :	0.00	(Figure 6-5)
Velocity Pressure, q _h [psf]:	18.8	(Equation 6-15)
Gust Effect Factor, G:	0.85	(Section 6.5.8)
Panel Slope [degrees]:	35.0	

Net Pressure Coefficients (C_N) per: (Figure 6-18A)

Clear Wind Flow	C _{NW}	C _{NL}
Case 1 (γ = 0°, Load Case A)	-1.80	-1.80
Case 2 (γ = 0°, Load Case B)	-2.43	-0.57
Case 3 (γ = 180°, Load Case A)	2.10	2.17
Case 4 (γ = 180°, Load Case B)	2.67	1.07

Design Wind Pressures (p) [psf] per: (Equation 6-25)

Clear Wind Flow	q _h GC _{NW}	q _h GC _{NL}
Case 1 (γ = 0°, Load Case A)	-28.8	-28.8
Case 2 (γ = 0°, Load Case B)	-39.0	-9.1
Case 3 (γ = 180°, Load Case A)	33.6	34.7
Case 4 (γ = 180°, Load Case B)	42.7	17.1

Wind Pressure on Each Side of Panels [psf]

Clear Wind Flow	Short Col. Pressure	Long Col. Pressure
Case 1 (γ = 0°, Load Case A)	-28.8	-28.8
Case 2 (γ = 0°, Load Case B)	-9.1	-39.0
Case 3 (γ = 180°, Load Case A)	33.6	34.7
Case 4 (γ = 180°, Load Case B)	42.7	17.1



JOB NO.: U2716-091-191

PROJECT: A2 – Sunmodo Sunturf GM

SUBJECT: Open Building Wind Loads

Design Wind Load Per ASCE 7-05

$$p = q_h G C_n$$

Velocity Pressure Exposure Coefficient, K_{zt} :	0.85	(Table 6-3)
Topographic Factor, K_{ht} :	1.0	(Section 6.5.7.2)
Wind Directionality Factor, K_d :	0.85	(Table 6-4)
Ultimate Wind Speed, V [mph]:	115	

Velocity Pressure, q_h [psf]:	18.8	(Equation 6-15)
Gust Effect Factor, G :	0.85	(Section 6.5.8)

$\gamma = 90^\circ$ or 270°

Force Coefficient, C_N :

Horizontal Distance from Winward Edge	Roof angle			Obstructed Wind Flow
	35	A	CN	
$\leq h$	35	A	-0.8	
		B	0.8	
$> h, \leq 2h$	35	A	-0.6	
		B	0.5	
$> 2h$	35	A	-0.3	
		B	0.3	

Design Wind Pressure, p [psf]:

Horizontal Distance from Winward Edge	Roof angle			Obstructed Wind Flow
	35	A		
$\leq h$	35	A	-12.8	
		B	12.8	
$> h, \leq 2h$	35	A	-9.6	
		B	8.0	
$> 2h$	35	A	-4.8	
		B	4.8	



JOB NO.: U2716-092-191

DESIGNED: STB

Foundation Option 1: Drilled Concrete Pier



PROJECT: Links Not Updated Ground Mount

DRILLED CONCRETE PIER DESIGN

Column Reactions:

Max. Shear, V [k]:	1.7	Max. Down, P _d [k]:	2.8
Max. Moment, M [k-ft]:	0.0	Max. Uplift, P _u [k]:	2.4

Pier Properties:

Pier Shape:	Round	Volume of Concrete [ft ³]:	11
Pier Diameter, b [ft]:	1.5	Volume of Concrete [yd ³]:	0.4
Top of Pier Elevation [ft]:	0.00	Weight of Concrete [k]:	1.6
Pier Depth, d [ft]:	6.0		

Soil Properties:

Allow. Bearing Pressure [psf]:	1,500	<u>Optional Parameters for Uplift:</u>	
1/3 increase for short term loads?	No		
Lateral Bearing, S [pcf]:	150	Skin Friction* [psf]:	250
Max. Lateral Bearing (opt'l) [psf]:		Top Length to Ignore [ft]:	0
Top Depth to Ignore [ft]:	0	1/3 increase for short term loads?	No
1/3 increase for short term loads?	No	Combine w/ Bearing:	No
1/2" deflection at t/o pier allowed:	Yes		

*per IBC Section 1810.3.3.1.4

Check Bearing:

Bearing Capacity [k]:	7.1
-----------------------	-----

Bearing capacity OK.

Check Uplift:

Uplift Capacity [k]:	8.5
----------------------	-----

Uplift capacity OK.

Check Lateral Bearing:

Top of Pier Constrained?:	No
Applied Lateral Force, P [lb]:	1,665
Point of Application, h [ft]:	0.0
S _{max} [psf]:	
S [psf]:	600
A = 2.34*P/(Sb):	4.33
Required Pier Depth, d _{reqd} [ft]:	4.30

IBC Section 1807.3.2.1

IBC Eq. 18-1

Result: **Lateral bearing capacity OK.**

Foundation Option 2: Helical Pier

The ground screws and helical piers must be tested to 1.5 times uplift and 2.0 times lateral reactions found in the table below.

Load (ASD)	Value (lbs)	Factor of Safety	Test Value (lbs)
UPLIFT	2385	1.5	3578
LATERAL	1665	2	3330

Foundation Option 3: Ground Screw

The ground screws and helical piers must be tested to 1.5 times uplift and 2.0 times lateral reactions found in the table below.

Load (ASD)	Value (lbs)	Factor of Safety	Test Value (lbs)
UPLIFT	2385	1.5	3578
LATERAL	1665	2	3330



JOB NO.: U2716-092-191

DESIGNED: STB

Foundation Option 4: Ballasted Block

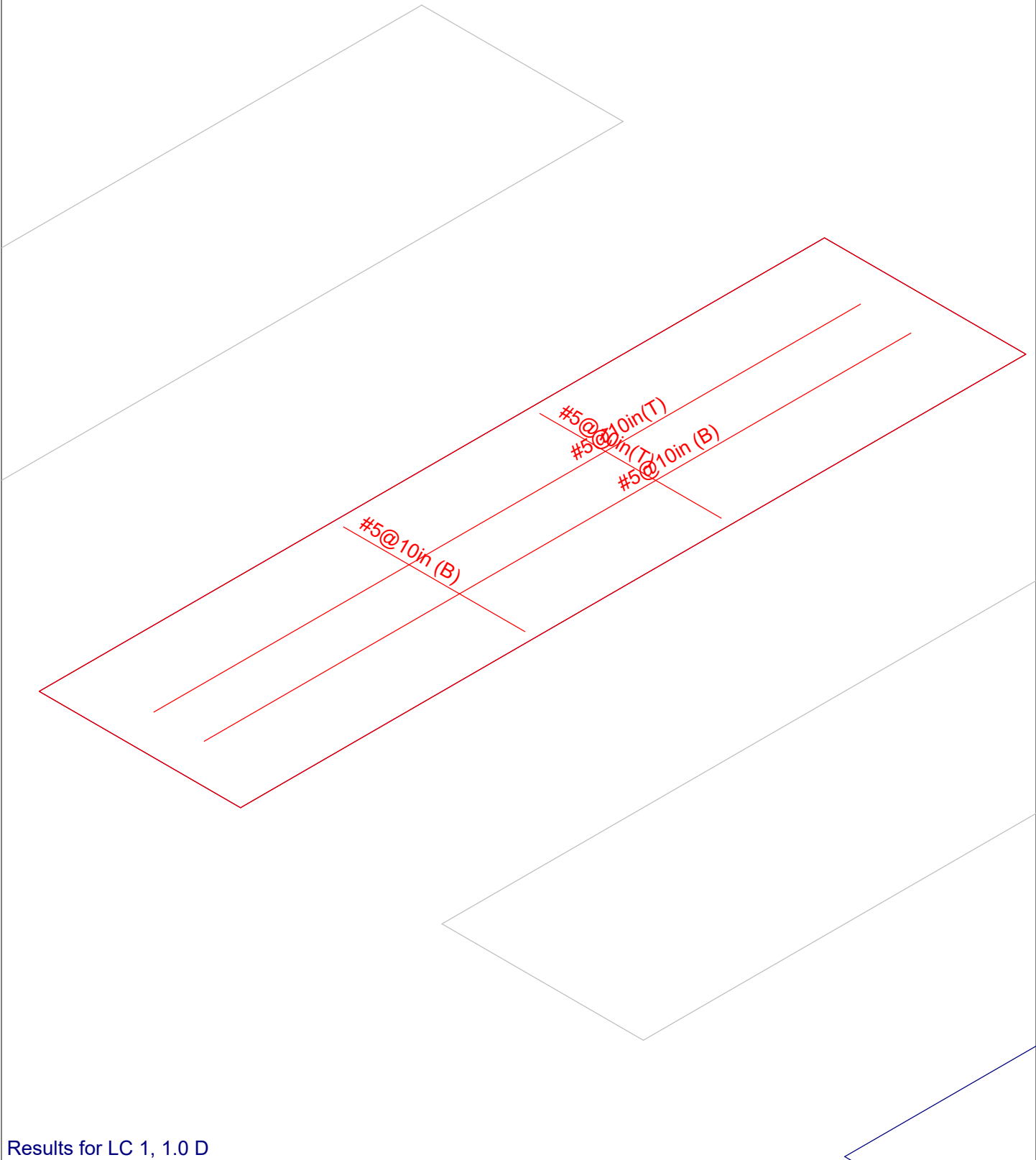

Results for LC 1, 1.0 D

Vector Structural Engineeri...	Ground Mount	SK - 1
STB		Apr 12, 2021 at 3:56 PM
U2716.092.181		Sunmodo Sunturf A2 v5 85x45.r3d

(Global) Model Settings

Display Sections for Member Calcs	5
Max Internal Sections for Member Calcs	100
Mesh Size (in)	12
Max Iterations	10
Merge Tolerance (in)	.12
Solver	Sparse Accelerated
Coefficient of Friction	.3
No. of Shear Regions	4
Shear Region Spacing Increment (in)	4
Min 1 Bar Dia Spacing for Beams?	No
Optimize footings for OTM / Sliding?	Yes
Parame Beta Factor	.65
Pile Safety Factor	3
Concrete Stress Block	0
Concrete Rebar Set	Rectangular
Concrete Code	ASTM A615
HR Steel Pile Code	ACI 318-08
Wood Pile Code	AISC 14th (360-10): ASD AWC NDS-15: ASD

Concrete Properties

	Label	E [ksi]	G [ksi]	Nu	Therm (/...	Density[lb/ft^3]	fc[psi]	Lambda	Flex Stee...	Shear St...
1	Conc3000NW	3156	1372	.15	.6	145	3000	1	60000	60000
2	Conc3500NW	3409	1482	.15	.6	145	3500	1	60000	60000
3	Conc4000NW	3644	1584	.15	.6	145	4000	1	60000	60000
4	Conc3000LW	2085	907	.15	.6	109.999	3000	.75	60000	60000
5	Conc3500LW	2252	979	.15	.6	109.999	3500	.75	60000	60000
6	Conc4000LW	2408	1047	.15	.6	109.999	4000	.75	60000	60000
7	Conc2500NW	3156	1372	.15	.6	145	2500	1	60000	60000

General Design Parameters

	Label	Max Bending Chk	Max Shear Chk	Top Cover[in]	Bottom Cover[in]
1	Typical	1	1	3	3

Slab Rebar Parameters

	Label	Top Bar	Bottom Bar	Max Top Bar Sp...	Min Top Bar Sp...	Max Bot Bar Sp...	Min Bot Bar Sp...	Spacing Incr...	Rebar Options
1	Typical	#5	#5	10	10	10	10	1	Optimize

Soil Definitions

	Label	Subgrade Modulus[lb/ft^3]	Allowable Bearing[psf]	Depth Properties	Default?
1	Default	1e+5	1500	None	Yes

Point Loads and Moments (Cat 1 : DL)

	Label	Direction	Magnitude[lb,lb-ft]
1	R3D_N1_1	X	-3.417
2	R3D_N1_1	Y	182.011
3	R3D_N2_1	Y	164.498
4	R3D_N132_1	Y	174.094
5	R3D_N133_1	Y	169.146
6	R3D_N109_1	Y	170.193
7	R3D_N110A_1	Y	168.749
8	R3D_N121_1	Y	175.183

Point Loads and Moments (Cat 1 : DL) (Continued)

	Label	Direction	Magnitude[lb,lb-ft]
9	R3D_N122_1	Y	170.534
10	R3D_N133B_1	Y	175.66
11	R3D_N134B_1	Y	171.186
12	R3D_N151_1	Y	174.016
13	R3D_N152_1	Y	169.059
14	R3D_N157A_2	Y	175.566
15	R3D_N158A_2	Y	171.061
16	R3D_N157	Y	175.343
17	R3D_N158	Y	170.746
18	R3D_N157B	X	3.442
19	R3D_N157B	Y	181.819
20	R3D_N158B	Y	164.269
21	R3D_N161C	Y	170.245
22	R3D_N162C	Y	168.811

Point Loads and Moments (Cat 6 : RLL)

	Label	Direction	Magnitude[lb,lb-ft]
1	R3D_N1_1	X	-8.278
2	R3D_N1_1	Y	358.382
3	R3D_N2_1	X	-1.651
4	R3D_N2_1	Y	369.102
5	R3D_N132_1	Y	355.91
6	R3D_N133_1	X	-1.731
7	R3D_N133_1	Y	382.11
8	R3D_N109_1	Y	339.637
9	R3D_N110A_1	Y	382.406
10	R3D_N121_1	Y	359.596
11	R3D_N122_1	Y	385.861
12	R3D_N133B_1	Y	360.072
13	R3D_N134B_1	Y	387.588
14	R3D_N151_1	Y	355.726
15	R3D_N152_1	X	1.641
16	R3D_N152_1	Y	381.93
17	R3D_N157A_2	Y	359.815
18	R3D_N158A_2	Y	387.255
19	R3D_N157	Y	360.028
20	R3D_N158	Y	386.403
21	R3D_N157B	X	8.343
22	R3D_N157B	Y	358.172
23	R3D_N158B	X	1.672
24	R3D_N158B	Y	368.759
25	R3D_N161C	Y	339.647
26	R3D_N162C	Y	382.548

Point Loads and Moments (Cat 16 : OL1)

	Label	Direction	Magnitude[lb,lb-ft]
1	R3D_N1_1	X	29.265
2	R3D_N1_1	Y	-2095.55
3	R3D_N1_1	Z	1327.939
4	R3D_N2_1	X	2.72
5	R3D_N2_1	Y	331.275
6	R3D_N2_1	Z	-133.092
7	R3D_N132_1	X	1.787
8	R3D_N132_1	Y	-2124.048
9	R3D_N132_1	Z	1379.932
10	R3D_N133_1	X	1.563

Point Loads and Moments (Cat 16 : OL1) (Continued)

	Label	Direction	Magnitude[lb.-lb-ft]
11	R3D_N133_1	Y	351.087
12	R3D_N133_1	Z	-137.01
13	R3D_N109_1	X	1.113
14	R3D_N109_1	Y	-2045.546
15	R3D_N109_1	Z	1369.287
16	R3D_N110A_1	Y	333.811
17	R3D_N110A_1	Z	-135.419
18	R3D_N121_1	Y	-2167.685
19	R3D_N121_1	Z	1401.539
20	R3D_N122_1	X	-3.252
21	R3D_N122_1	Y	376.026
22	R3D_N122_1	Z	-137.636
23	R3D_N133B_1	Y	-2139.791
24	R3D_N133B_1	Z	1386.53
25	R3D_N134B_1	Y	346.773
26	R3D_N134B_1	Z	-137.396
27	R3D_N151_1	X	-1.656
28	R3D_N151_1	Y	-2126.706
29	R3D_N151_1	Z	1381.995
30	R3D_N152_1	X	-1.325
31	R3D_N152_1	Y	354.527
32	R3D_N152_1	Z	-137.063
33	R3D_N157A_2	X	-1.072
34	R3D_N157A_2	Y	-2134.526
35	R3D_N157A_2	Z	1383.036
36	R3D_N158A_2	Y	342.874
37	R3D_N158A_2	Z	-137.264
38	R3D_N157	Y	-2172.014
39	R3D_N157	Z	1404.275
40	R3D_N158	X	3.306
41	R3D_N158	Y	378.394
42	R3D_N158	Z	-137.755
43	R3D_N157B	X	-29.52
44	R3D_N157B	Y	-2091.556
45	R3D_N157B	Z	1326.027
46	R3D_N158B	X	-3.008
47	R3D_N158B	Y	329.403
48	R3D_N158B	Z	-132.986
49	R3D_N161C	Y	-2047.903
50	R3D_N161C	Z	1370.442
51	R3D_N162C	Y	334.845
52	R3D_N162C	Z	-135.478

Point Loads and Moments (Cat 17 : OL2)

	Label	Direction	Magnitude[lb.-lb-ft]
1	R3D_N1_1	X	38.555
2	R3D_N1_1	Y	-2422.506
3	R3D_N1_1	Z	1154.053
4	R3D_N2_1	Y	866.174
5	R3D_N2_1	Z	-115.55
6	R3D_N132_1	X	2.345
7	R3D_N132_1	Y	-2431.534
8	R3D_N132_1	Z	1196.748
9	R3D_N133_1	X	-1.637
10	R3D_N133_1	Y	890.95
11	R3D_N133_1	Z	-118.88

Point Loads and Moments (Cat 17 : OL2) (Continued)

	Label	Direction	Magnitude[lb,lb-ft]
12	R3D_N109_1	X	1.421
13	R3D_N109_1	Y	-2331.272
14	R3D_N109_1	Z	1182.524
15	R3D_N110A_1	Y	873.303
16	R3D_N110A_1	Z	-117.28
17	R3D_N121_1	Y	-2486.068
18	R3D_N121_1	Z	1222.37
19	R3D_N122_1	X	-2.364
20	R3D_N122_1	Y	927.38
21	R3D_N122_1	Z	-119.709
22	R3D_N133B_1	X	1.201
23	R3D_N133B_1	Y	-2452.429
24	R3D_N133B_1	Z	1203.27
25	R3D_N134B_1	X	-1.994
26	R3D_N134B_1	Y	898.281
27	R3D_N134B_1	Z	-119.309
28	R3D_N151_1	X	-2.17
29	R3D_N151_1	Y	-2434.779
30	R3D_N151_1	Z	1199.361
31	R3D_N152_1	X	1.744
32	R3D_N152_1	Y	894.695
33	R3D_N152_1	Z	-118.948
34	R3D_N157A_2	X	-1.396
35	R3D_N157A_2	Y	-2445.748
36	R3D_N157A_2	Z	1199.011
37	R3D_N158A_2	X	2.134
38	R3D_N158A_2	Y	892.714
39	R3D_N158A_2	Z	-119.148
40	R3D_N157	Y	-2491.62
41	R3D_N157	Z	1225.653
42	R3D_N158	X	2.398
43	R3D_N158	Y	931.616
44	R3D_N158	Z	-119.851
45	R3D_N157B	X	-38.905
46	R3D_N157B	Y	-2417.411
47	R3D_N157B	Z	1151.843
48	R3D_N158B	Y	863.363
49	R3D_N158B	Z	-115.428
50	R3D_N161C	X	-1.148
51	R3D_N161C	Y	-2334.466
52	R3D_N161C	Z	1183.846
53	R3D_N162C	Y	874.762
54	R3D_N162C	Z	-117.349

Point Loads and Moments (Cat 18 : OL3)

	Label	Direction	Magnitude[lb,lb-ft]
1	R3D_N1_1	X	-35.22
2	R3D_N1_1	Y	2509.571
3	R3D_N1_1	Z	-1576.283
4	R3D_N2_1	X	-3.16
5	R3D_N2_1	Y	-414.502
6	R3D_N2_1	Z	157.977
7	R3D_N132_1	X	-2.15
8	R3D_N132_1	Y	2542.82
9	R3D_N132_1	Z	-1637.908
10	R3D_N133_1	X	-1.745

Point Loads and Moments (Cat 18 : OL3) (Continued)

	Label	Direction	Magnitude[lb,lb-ft]
11	R3D N133 1	Y	-438.298
12	R3D N133 1	Z	162.626
13	R3D N109 1	X	-1.338
14	R3D N109 1	Y	2448.457
15	R3D N109 1	Z	-1625.089
16	R3D N110A 1	Y	-417.695
17	R3D N110A 1	Z	160.729
18	R3D N121 1	Y	2595.228
19	R3D N121 1	Z	-1663.807
20	R3D N122 1	X	3.843
21	R3D N122 1	Y	-468.444
22	R3D N122 1	Z	163.38
23	R3D N133B 1	X	-1.111
24	R3D N133B 1	Y	2561.773
25	R3D N133B 1	Z	-1645.768
26	R3D N134B 1	Y	-433.585
27	R3D N134B 1	Z	163.087
28	R3D N151 1	X	1.993
29	R3D N151 1	Y	2546.009
30	R3D N151 1	Z	-1640.387
31	R3D N152 1	X	1.467
32	R3D N152 1	Y	-442.409
33	R3D N152 1	Z	162.69
34	R3D N157A 2	X	1.289
35	R3D N157A 2	Y	2555.445
36	R3D N157A 2	Z	-1641.576
37	R3D N158A 2	Y	-428.876
38	R3D N158A 2	Z	162.929
39	R3D N157	Y	2600.433
40	R3D N157	Z	-1667.088
41	R3D N158	X	-3.907
42	R3D N158	Y	-471.335
43	R3D N158	Z	163.522
44	R3D N157B	X	35.528
45	R3D N157B	Y	2504.771
46	R3D N157B	Z	-1573.993
47	R3D N158B	X	3.505
48	R3D N158B	Y	-412.237
49	R3D N158B	Z	157.851
50	R3D N161C	X	1.096
51	R3D N161C	Y	2451.297
52	R3D N161C	Z	-1626.471
53	R3D N162C	Y	-418.942
54	R3D N162C	Z	160.8

Point Loads and Moments (Cat 19 : OL4)

	Label	Direction	Magnitude[lb,lb-ft]
1	R3D N1 1	X	18.296
2	R3D N1 1	Y	-1599.738
3	R3D N1 1	Z	1340.018
4	R3D N2 1	X	4.33
5	R3D N2 1	Y	-160.826
6	R3D N2 1	Z	-134.4
7	R3D N132 1	X	1.125
8	R3D N132 1	Y	-1641.969
9	R3D N132 1	Z	1394.616

Point Loads and Moments (Cat 19 : OL4) (Continued)

	Label	Direction	Magnitude[lb.lb-ft]
10	R3D_N133_1	X	4.142
11	R3D_N133_1	Y	-147.305
12	R3D_N133_1	Z	-138.419
13	R3D_N109_1	Y	-1590.184
14	R3D_N109_1	Z	1388.131
15	R3D_N110A_1	Y	-162.483
16	R3D_N110A_1	Z	-136.999
17	R3D_N121_1	Y	-1671.781
18	R3D_N121_1	Z	1410.56
19	R3D_N122_1	X	-3.677
20	R3D_N122_1	Y	-134.773
21	R3D_N122_1	Z	-138.807
22	R3D_N133B_1	Y	-1651.681
23	R3D_N133B_1	Z	1400.599
24	R3D_N134B_1	Y	-161.145
25	R3D_N134B_1	Z	-138.727
26	R3D_N151_1	X	-1.046
27	R3D_N151_1	Y	-1643.85
28	R3D_N151_1	Z	1395.995
29	R3D_N152_1	X	-3.817
30	R3D_N152_1	Y	-144.48
31	R3D_N152_1	Z	-138.453
32	R3D_N157A_2	Y	-1648.168
33	R3D_N157A_2	Z	1398.12
34	R3D_N158A_2	X	-1.398
35	R3D_N158A_2	Y	-163.214
36	R3D_N158A_2	Z	-138.634
37	R3D_N157	Y	-1674.616
38	R3D_N157	Z	1412.545
39	R3D_N158	X	3.744
40	R3D_N158	Y	-134.249
41	R3D_N158	Z	-138.893
42	R3D_N157B	X	-18.444
43	R3D_N157B	Y	-1597.098
44	R3D_N157B	Z	1338.557
45	R3D_N158B	X	-4.548
46	R3D_N158B	Y	-161.7
47	R3D_N158B	Z	-134.32
48	R3D_N161C	Y	-1591.582
49	R3D_N161C	Z	1389.024
50	R3D_N162C	Y	-161.919
51	R3D_N162C	Z	-137.043

Point Loads and Moments (Cat 20 : OL5)

	Label	Direction	Magnitude[lb.lb-ft]
1	R3D_N1_1	X	-11.632
2	R3D_N1_1	Y	952.455
3	R3D_N1_1	Z	-599.598
4	R3D_N2_1	X	-3.295
5	R3D_N2_1	Y	-150.886
6	R3D_N2_1	Z	56.191
7	R3D_N132_1	Y	340.155
8	R3D_N132_1	Z	-224.855
9	R3D_N133_1	Y	-59.196
10	R3D_N133_1	Z	25.49
11	R3D_N109_1	Y	780.241

Point Loads and Moments (Cat 20 : OL5) (Continued)

	Label	Direction	Magnitude[lb,lb-ft]
12	R3D_N109_1	Z	-523.701
13	R3D_N110A_1	X	1.857
14	R3D_N110A_1	Y	-133.964
15	R3D_N110A_1	Z	50.67
16	R3D_N121_1	Y	706.401
17	R3D_N121_1	Z	-453.047
18	R3D_N122_1	Y	-117.287
19	R3D_N122_1	Z	43.253
20	R3D_N133B_1	Y	480.304
21	R3D_N133B_1	Z	-312.905
22	R3D_N134B_1	X	2.725
23	R3D_N134B_1	Y	-80.469
24	R3D_N134B_1	Z	32.824
25	R3D_N151_1	Y	355.593
26	R3D_N151_1	Z	-230.547
27	R3D_N152_1	Y	-56.877
28	R3D_N152_1	Z	23.665
29	R3D_N157A_2	Y	355.421
30	R3D_N157A_2	Z	-230.938
31	R3D_N158A_2	Y	-57.758
32	R3D_N158A_2	Z	23.142
33	R3D_N157	Y	362.63
34	R3D_N157	Z	-233.704
35	R3D_N158	Y	-62.435
36	R3D_N158	Z	23.026
37	R3D_N157B	X	7.938
38	R3D_N157B	Y	357.699
39	R3D_N157B	Z	-221.024
40	R3D_N158B	Y	-56.627
41	R3D_N158B	Z	22.175
42	R3D_N161C	Y	334.092
43	R3D_N161C	Z	-228.726
44	R3D_N162C	Y	-56.419
45	R3D_N162C	Z	22.621

Point Loads and Moments (Cat 21 : OL6)

	Label	Direction	Magnitude[lb,lb-ft]
1	R3D_N1_1	X	13.185
2	R3D_N1_1	Y	-960.595
3	R3D_N1_1	Z	602.004
4	R3D_N2_1	X	3.63
5	R3D_N2_1	Y	151.241
6	R3D_N2_1	Z	-55.426
7	R3D_N132_1	Y	-633.353
8	R3D_N132_1	Z	411.582
9	R3D_N133_1	Y	104.661
10	R3D_N133_1	Z	-40.805
11	R3D_N109_1	Y	-713.145
12	R3D_N109_1	Z	481.752
13	R3D_N110A_1	X	-2.928
14	R3D_N110A_1	Y	119.985
15	R3D_N110A_1	Z	-48.144
16	R3D_N121_1	Y	-592.533
17	R3D_N121_1	Z	387.643
18	R3D_N122_1	Y	109.602
19	R3D_N122_1	Z	-41.658



Company : Vector Structural Engineering
 Designer : STB
 Job Number : U2716.092.181
 Model Name : Ground Mount

Apr 12, 2021
 3:56 PM
 Checked By: JSP

Point Loads and Moments (Cat 21 : OL6) (Continued)

	Label	Direction	Magnitude [lb.-ft]
20	R3D N133B 1	Y	-625.727
21	R3D N133B 1	Z	403.582
22	R3D N134B 1	X	-1.017
23	R3D N134B 1	Y	97.866
24	R3D N134B 1	Z	-40.694
25	R3D N151 1	Y	-635.977
26	R3D N151 1	Z	413.281
27	R3D N152 1	Y	106.214
28	R3D N152 1	Z	-40.926
29	R3D N157A 2	Y	-637.205
30	R3D N157A 2	Z	412.99
31	R3D N158A 2	Y	102.494
32	R3D N158A 2	Z	-40.981
33	R3D N157	Y	-648.619
34	R3D N157	Z	418.756
35	R3D N158	X	1.077
36	R3D N158	Y	112.158
37	R3D N158	Z	-41.111
38	R3D N157B	X	-10.711
39	R3D N157B	Y	-632.827
40	R3D N157B	Z	396.045
41	R3D N158B	X	-1.005
42	R3D N158B	Y	101.278
43	R3D N158B	Z	-39.714
44	R3D N161C	Y	-606.825
45	R3D N161C	Z	409.624
46	R3D N162C	Y	100.995
47	R3D N162C	Z	-40.476

Slabs

	Label	Thickness [in]	Material	Local Axis Angle ...	Analysis Offset [in]	Passive Pressur...	Soil Overburden [psf]
1	S1	30	Conc2500NW	0	0	0	0
2	S2	30	Conc2500NW	0	0	0	0
3	S3	30	Conc2500NW	0	0	0	0
4	S4	30	Conc2500NW	0	0	0	0
5	S5	30	Conc2500NW	0	0	0	0
6	S6	30	Conc2500NW	0	0	0	0
7	S7	30	Conc2500NW	0	0	0	0
8	S8	30	Conc2500NW	0	0	0	0
9	S9	30	Conc2500NW	0	0	0	0
10	S10	30	Conc2500NW	0	0	0	0

Load Combinations

	Label	Solve	Service A...	SF	Cat...	Fa...	Cat...	Fa...	Cat...	Fa...	Cat...	Fa...	Cat...	Fa...	C...	F...	C...	F...
1	1.0 D	Yes	Yes	1.5	DL	1												
2	1.0 D + 1....	Yes	Yes	1.5	DL	1	RLL	1										
3	1.0 D + 0....	Yes	Yes	1.5	DL	1	RLL	OL1	1									
4	1.0 D + 0....	Yes	Yes	1.5	DL	1	RLL	OL2	1									
5	1.0 D + 0....	Yes	Yes	1.5	DL	1	RLL	OL3	1									
6	1.0 D + 0....	Yes	Yes	1.5	DL	1	RLL	OL4	1									
7	1.0 D + 0....	Yes	Yes	1.5	DL	1	RLL	OL5	1									
8	1.0 D + 0....	Yes	Yes	1.5	DL	1	RLL	OL6	1									
9	1.0 D + 0....	Yes	Yes	1.5	DL	1	RLL	.75	OL1	.75								
10	1.0 D + 0....	Yes	Yes	1.5	DL	1	RLL	.75	OL2	.75								
11	1.0 D + 0....	Yes	Yes	1.5	DL	1	RLL	.75	OL3	.75								
12	1.0 D + 0....	Yes	Yes	1.5	DL	1	RLL	.75	OL4	.75								

Load Combinations (Continued)

Label	Solve	Service	A...	SF	Cat..	Fa...	Cat..	Fa...	Cat..	Fa...	Cat..	Fa...	Cat..	Fa...	Cat..	Fa...	Cat..	Fa...
13	1.0 D + 0...	Yes	Yes	1.5	DL	1	RLL	.75	OL5	.75								
14	1.0 D + 0...	Yes	Yes	1.5	DL	1	RLL	.75	OL6	.75								
15	0.9 D + 0...	Yes	Yes		DL	.9	RLL		OL1	1								
16	0.9 D + 0...	Yes	Yes		DL	.9	RLL		OL2	1								
17	0.6 D + 0...	Yes	Yes		DL	.9	RLL		OL3	1								
18	0.9 D + 0...	Yes	Yes		DL	.9	RLL		OL4	1								
19	0.9 D + 0...	Yes	Yes		DL	.9	RLL		OL5	1								
20	0.9 D + 0...	Yes	Yes		DL	.9	RLL		OL6	1								
21																		
22	1.4D	Yes			DL	1.4												
23	1.2D+1.6SL	Yes			DL	1.2	RLL	1.6										
24	1.2D+1.6S...	Yes			DL	1.2	RLL	1.6	OL1	.8								
25	1.2D+1.6S...	Yes			DL	1.2	RLL	1.6	OL2	.8								
26	1.2D+1.6S...	Yes			DL	1.2	RLL	1.6	OL3	.8								
27	1.2D+1.6S...	Yes			DL	1.2	RLL	1.6	OL4	.8								
28	1.2D+1.6S...	Yes			DL	1.2	RLL	1.6	OL5	.8								
29	1.2D+1.6S...	Yes			DL	1.2	RLL	1.6	OL6	.8								
30	1.2D+1.6...	Yes			DL	1.2	RLL	.5	OL1	1.6								
31	1.2D-1.6...	Yes			DL	1.2	RLL	.5	OL2	1.6								
32	1.2D+1.6...	Yes			DL	1.2	RLL	.5	OL3	1.6								
33	1.2D-1.6...	Yes			DL	1.2	RLL	.5	OL4	1.6								
34	1.2D+1.6...	Yes			DL	1.2	RLL	.5	OL5	1.6								
35	1.2D-1.6...	Yes			DL	1.2	RLL	.5	OL6	1.6								
36	1.0D+1.6...	Yes			DL	1			OL1	1.6								
37	1.0D-1.6Wx	Yes			DL	1			OL2	1.6								
38	1.0D+1.6...	Yes			DL	1			OL3	1.6								
39	1.0D-1.6Wz	Yes			DL	1			OL4	1.6								
40	1.0D+1.6...	Yes			DL	1			OL5	1.6								
41	1.0D-1.6...	Yes			DL	1			OL6	1.6								

Design Strips

Label	Rebar Angle from Pl...	No. of Design Cuts	Design Rule	
1	DS1	0	50	Typical
2	DS2	90	50	Typical

Load Categories

Category	Point Loads	Line Loads	Area Loads
1	DL	22	
2	RLL	26	
3	OL1	52	
4	OL2	54	
5	OL3	54	
6	OL4	51	
7	OL5	45	
8	OL6	47	

Strip Reinforcing

Label	UC Top	LC	Top Bars	Governing ...	UC Bot	LC	Bot B...	Gover...	UC Shear	LC	Governing De...
1	DS1	.015	32	#5@10in	DS1-X25	.012	37	#5@1...DS1-...	.024	32	DS1-X15
2	DS2	.002	39	#5@10in	DS2-X26	.003	32	#5@1...DS2-...	.004	32	DS2-X25



Company : Vector Structural Engineering
 Designer : STB
 Job Number : U2716.092.181
 Model Name : Ground Mount

Apr 12, 2021
 3:56 PM
 Checked By: JSP

Slab Overturning Safety Factors (By Combination)

	LC	Slab	Angle[deg]	Mo-xx[lb-ft]	Ms-xx[lb-ft]	Mo-zz[lb-ft]	Ms-zz[lb-ft]	Ms-xx/Mo-xx	Ms-zz/Mo-zz
1	1	S1	0	0	44716.256	0	11486.62	9.999+	9.999+
2	1	S2	0	0	44736.628	0	11468.618	9.999+	9.999+
3	1	S3	0	0	44758.458	0	11477.087	9.999+	9.999+
4	1	S4	0	0	44764.639	0	11478.499	9.999+	9.999+
5	1	S5	0	0	44745.204	0	11473.99	9.999+	9.999+
6	1	S6	0	0	44744.361	0	11473.784	9.999+	9.999+
7	1	S7	0	0	44763.452	0	11478.225	9.999+	9.999+
8	1	S8	0	0	44760.474	0	11477.552	9.999+	9.999+
9	1	S9	0	0	44737.227	0	11468.76	9.999+	9.999+
10	1	S10	0	0	44714.053	0	11468.945	9.999+	9.999+
11	2	S1	0	0	48331.459	0	12420.796	9.999+	9.999+
12	2	S2	0	0	48439.927	0	12371.171	9.999+	9.999+
13	2	S3	0	0	48517.739	0	12408.91	9.999+	9.999+
14	2	S4	0	0	48539.234	0	12413.075	9.999+	9.999+
15	2	S5	0	0	48467.686	0	12400.842	9.999+	9.999+
16	2	S6	0	0	48465.06	0	12391.75	9.999+	9.999+
17	2	S7	0	0	48534.869	0	12412.063	9.999+	9.999+
18	2	S8	0	0	48524.936	0	12410.591	9.999+	9.999+
19	2	S9	0	0	48441.74	0	12371.503	9.999+	9.999+
20	2	S10	0	0	48326.061	0	12352.572	9.999+	9.999+
21	3	S1	0	20210.611	44812.902	2285.305	11486.62	2.217	5.026
22	3	S2	0	19884.116	44718.744	2142.451	11468.618	2.249	5.353
23	3	S3	0	20934.444	44762.976	2247.702	11477.087	2.138	5.106
24	3	S4	0	20699.319	44767.805	2241.273	11478.499	2.163	5.121
25	3	S5	0	20545.887	44752.07	2224.575	11473.99	2.178	5.158
26	3	S6	0	20568.981	44751.305	2222.677	11473.784	2.176	5.162
27	3	S7	0	20651.468	44766.858	2242.245	11478.225	2.168	5.119
28	3	S8	0	20974.46	44764.584	2250.29	11477.552	2.134	5.1
29	3	S9	0	19905.402	44719.255	2141.322	11468.76	2.247	5.356
30	3	S10	0	20174.817	44810.997	2284.011	11486.157	2.221	5.029
31	4	S1	0	21902.996	44812.902	2041.802	11486.62	2.046	5.626
32	4	S2	0	21193.053	44718.744	1826.014	11468.618	2.11	6.281
33	4	S3	0	22521.864	44762.976	1954.27	11477.087	1.988	5.873
34	4	S4	0	22228.357	44767.805	1944.666	11478.499	2.014	5.903
35	4	S5	0	22046.43	44752.07	1927.501	11473.99	2.03	5.953
36	4	S6	0	22075.421	44751.305	1926.168	11473.784	2.027	5.957
37	4	S7	0	22168.848	44766.858	1943.137	11478.225	2.019	5.907
38	4	S8	0	22571.153	44764.584	1956	11477.552	1.983	5.868
39	4	S9	0	21221.24	44719.255	1827.499	11468.76	2.107	6.276
40	4	S10	0	21858.414	44810.997	2039.822	11486.157	2.05	5.631
41	5	S1	0	3722.945	44716.256	0	14201.408	9.999+	9.999+
42	5	S2	0	3946.701	44736.628	0	14010.417	9.999+	9.999+
43	5	S3	0	4272.549	44758.458	0	14125.961	9.999+	9.999+
44	5	S4	0	3976.487	44764.639	0	14141.511	9.999+	9.999+
45	5	S5	0	4023.32	44745.204	0	14114.38	9.999+	9.999+
46	5	S6	0	4060.052	44744.361	0	14094.634	9.999+	9.999+
47	5	S7	0	3934.811	44763.452	0	14133.213	9.999+	9.999+
48	5	S8	0	4298.026	44760.474	0	14148.692	9.999+	9.999+
49	5	S9	0	3956.799	44737.227	0	14006.465	9.999+	9.999+
50	5	S10	0	3704.684	44714.053	0	13987.028	9.999+	9.999+
51	6	S1	0	16679.575	44812.902	2257.27	11486.62	2.687	5.089
52	6	S2	0	16715.02	44718.744	2190.833	11468.618	2.675	5.235
53	6	S3	0	17418.711	44762.976	2267.384	11477.087	2.57	5.062
54	6	S4	0	17257.795	44767.805	2266.032	11478.499	2.594	5.065
55	6	S5	0	17144.565	44752.07	2249.757	11473.99	2.61	5.1
56	6	S6	0	17160.231	44751.305	2247.571	11473.784	2.608	5.105
57	6	S7	0	17224.855	44766.858	2267.724	11478.225	2.599	5.062



Company : Vector Structural Engineering
 Designer : STB
 Job Number : U2716.092.181
 Model Name : Ground Mount

Apr 12, 2021
 3:56 PM
 Checked By: JSP

Slab Overturning Safety Factors (By Combination) (Continued)

LC	Slab	Angle[deg]	Mo-xx[lb-ft]	Ms-xx[lb-ft]	Mo-zz[lb-ft]	Ms-zz[lb-ft]	Ms-xx/Mo-xx	Ms-zz/Mo-zz	
58	6	S8	0	17446.665	44764.584	2270.44	11477.552	2.566	5.055
59	6	S9	0	16728.204	44719.255	2191.876	11468.76	2.673	5.232
60	6	S10	0	16654.994	44810.997	2255.977	11486.157	2.691	5.091
61	7	S1	0	1371.113	44716.256	0	12525.898	9.999+	9.999+
62	7	S2	0	1280.954	44736.628	0	12271.822	9.999+	9.999+
63	7	S3	0	1079.555	44758.458	0	12213.481	9.999+	9.999+
64	7	S4	0	743.788	44764.639	0	11971.479	9.999+	9.999+
65	7	S5	0	548.037	44745.204	0	11825.189	9.999+	9.999+
66	7	S6	0	526.537	44744.361	0	11847.178	9.999+	9.999+
67	7	S7	0	536.537	44763.452	0	11850.304	9.999+	9.999+
68	7	S8	0	573.888	44760.474	0	11852.795	9.999+	9.999+
69	7	S9	0	549.366	44737.227	0	11815.852	9.999+	9.999+
70	7	S10	0	501.521	44714.053	0	11825.441	9.999+	9.999+
71	8	S1	0	9262.419	44812.902	1053.73	11486.62	4.838	9.999+
72	8	S2	0	6936.356	44718.744	748.77	11468.618	6.447	9.999+
73	8	S3	0	5715.126	44762.976	603.664	11477.087	7.832	9.999+
74	8	S4	0	6051.435	44767.805	662.368	11478.499	7.398	9.999+
75	8	S5	0	6126.843	44752.07	660.864	11473.99	7.304	9.999+
76	8	S6	0	6150.939	44751.305	662.204	11473.784	7.276	9.999+
77	8	S7	0	6165.057	44766.858	668.388	11478.225	7.261	9.999+
78	8	S8	0	6263.137	44764.584	673.27	11477.552	7.147	9.999+
79	8	S9	0	5904.083	44719.255	632.288	11468.76	7.574	9.999+
80	8	S10	0	6090.533	44810.997	693.725	11486.157	7.357	9.999+
81	9	S1	0	15157.958	47421.232	1713.979	12187.252	3.128	7.111
82	9	S2	0	14913.087	47221.217	1606.838	12145.533	3.166	7.559
83	9	S3	0	15700.833	47394.685	1685.777	12175.954	3.019	7.223
84	9	S4	0	15524.489	47404.138	1680.955	12179.431	3.054	7.246
85	9	S5	0	15409.415	47356.991	1668.431	12169.129	3.073	7.294
86	9	S6	0	15426.736	47354.896	1667.008	12168.413	3.07	7.3
87	9	S7	0	15488.601	47401.254	1681.684	12178.603	3.06	7.242
88	9	S8	0	15730.845	47399.525	1687.718	12177.331	3.013	7.215
89	9	S9	0	14929.052	47221.923	1605.991	12145.817	3.163	7.563
90	9	S10	0	15131.113	47417.683	1713.009	12186.432	3.134	7.114
91	10	S1	0	16427.247	47421.232	1531.352	12187.252	2.887	7.958
92	10	S2	0	15894.79	47221.217	1369.51	12145.533	2.971	8.869
93	10	S3	0	16891.398	47394.685	1465.702	12175.954	2.806	8.307
94	10	S4	0	16671.267	47404.138	1458.499	12179.431	2.843	8.351
95	10	S5	0	16534.822	47356.991	1445.626	12169.129	2.864	8.418
96	10	S6	0	16556.566	47354.896	1444.626	12168.413	2.86	8.423
97	10	S7	0	16626.636	47401.254	1457.353	12178.603	2.851	8.357
98	10	S8	0	16928.365	47399.525	1467	12177.331	2.8	8.301
99	10	S9	0	15915.93	47221.923	1370.624	12145.817	2.967	8.862
100	10	S10	0	16393.811	47417.683	1529.867	12186.432	2.892	7.966
101	11	S1	0	2792.208	47427.658	0	14223.343	9.999+	9.999+
102	11	S2	0	2960.025	47514.102	0	14051.882	9.999+	9.999+
103	11	S3	0	3204.411	47577.919	0	14162.609	9.999+	9.999+
104	11	S4	0	2982.365	47595.586	0	14176.69	9.999+	9.999+
105	11	S5	0	3017.49	47537.066	0	14149.422	9.999+	9.999+
106	11	S6	0	3045.039	47534.885	0	14127.896	9.999+	9.999+
107	11	S7	0	2951.108	47592.015	0	14169.844	9.999+	9.999+
108	11	S8	0	3223.519	47583.821	0	14180.687	9.999+	9.999+
109	11	S9	0	2967.599	47515.612	0	14049.096	9.999+	9.999+
110	11	S10	0	2778.513	47423.059	0	14020.227	9.999+	9.999+
111	12	S1	0	12509.681	47421.232	1692.952	12187.252	3.791	7.199
112	12	S2	0	12536.265	47221.217	1643.125	12145.533	3.767	7.392
113	12	S3	0	13064.034	47394.685	1700.538	12175.954	3.628	7.16
114	12	S4	0	12943.346	47404.138	1699.524	12179.431	3.662	7.166



Company : Vector Structural Engineering
 Designer : STB
 Job Number : U2716.092.181
 Model Name : Ground Mount

Apr 12, 2021
 3:56 PM
 Checked By: JSP

Slab Overturning Safety Factors (By Combination) (Continued)

	LC	Slab	Angle[deg]	Mo-xx[lb-ft]	Ms-xx[lb-ft]	Mo-zz[lb-ft]	Ms-zz[lb-ft]	Ms-xx/Mo-xx	Ms-zz/Mo-zz
115	12	S5	0	12858.424	47356.991	1687.318	12169.129	3.683	7.212
116	12	S6	0	12870.173	47354.896	1685.679	12168.413	3.679	7.219
117	12	S7	0	12918.641	47401.254	1700.793	12178.603	3.669	7.161
118	12	S8	0	13084.999	47399.525	1702.83	12177.331	3.622	7.151
119	12	S9	0	12546.153	47221.923	1643.907	12145.817	3.764	7.388
120	12	S10	0	12491.245	47417.683	1691.983	12186.432	3.796	7.202
121	13	S1	0	1028.334	47427.658	0	12966.71	9.999+	9.999+
122	13	S2	0	960.715	47514.102	0	12747.936	9.999+	9.999+
123	13	S3	0	809.666	47577.919	0	12728.249	9.999+	9.999+
124	13	S4	0	557.841	47595.586	0	12549.166	9.999+	9.999+
125	13	S5	0	411.028	47537.066	0	12432.529	9.999+	9.999+
126	13	S6	0	394.903	47534.885	0	12442.304	9.999+	9.999+
127	13	S7	0	402.403	47592.015	0	12457.663	9.999+	9.999+
128	13	S8	0	430.416	47583.821	0	12458.764	9.999+	9.999+
129	13	S9	0	412.024	47515.612	0	12406.136	9.999+	9.999+
130	13	S10	0	376.141	47423.059	0	12399.037	9.999+	9.999+
131	14	S1	0	6946.815	47421.232	790.298	12187.252	6.826	9.999+
132	14	S2	0	5202.267	47221.217	561.577	12145.533	9.077	9.999+
133	14	S3	0	4286.344	47394.685	452.748	12175.954	9.999+	9.999+
134	14	S4	0	4538.577	47404.138	496.776	12179.431	9.999+	9.999+
135	14	S5	0	4595.132	47356.991	495.648	12162.639	9.999+	9.999+
136	14	S6	0	4613.204	47354.896	496.653	12162.258	9.999+	9.999+
137	14	S7	0	4623.793	47401.254	501.291	12178.603	9.999+	9.999+
138	14	S8	0	4697.353	47399.525	504.952	12177.331	9.999+	9.999+
139	14	S9	0	4428.062	47221.923	474.216	12145.817	9.999+	9.999+
140	14	S10	0	4567.9	47417.683	520.294	12186.432	9.999+	9.999+
141	15	S1	0	20210.611	40331.612	2285.305	10337.958	1.996	4.524
142	15	S2	0	19884.116	40246.869	2142.451	10321.756	2.024	4.818
143	15	S3	0	20934.444	40286.679	2247.702	10329.379	1.924	4.596
144	15	S4	0	20699.319	40291.025	2241.273	10330.649	1.946	4.609
145	15	S5	0	20545.887	40276.863	2224.575	10326.591	1.96	4.642
146	15	S6	0	20568.981	40276.174	2222.677	10326.405	1.958	4.646
147	15	S7	0	20651.468	40290.172	2242.245	10330.403	1.951	4.607
148	15	S8	0	20974.46	40288.125	2250.29	10329.797	1.921	4.59
149	15	S9	0	19905.402	40247.329	2141.322	10321.884	2.022	4.82
150	15	S10	0	20174.817	40329.897	2284.011	10337.541	1.999	4.526
151	16	S1	0	21902.996	40331.612	2041.802	10337.958	1.841	5.063
152	16	S2	0	21193.053	40246.869	1826.014	10321.756	1.899	5.653
153	16	S3	0	22521.864	40286.679	1954.27	10329.379	1.789	5.286
154	16	S4	0	22228.357	40291.025	1944.666	10330.649	1.813	5.312
155	16	S5	0	22046.43	40276.863	1927.501	10326.591	1.827	5.358
156	16	S6	0	22075.421	40276.174	1926.168	10326.405	1.824	5.361
157	16	S7	0	22168.848	40290.172	1943.137	10330.403	1.817	5.316
158	16	S8	0	22571.153	40288.125	1956	10329.797	1.785	5.281
159	16	S9	0	21221.24	40247.329	1827.499	10321.884	1.897	5.648
160	16	S10	0	21858.414	40329.897	2039.822	10337.541	1.845	5.068
161	17	S1	0	3722.945	40244.63	0	13052.746	9.999+	9.999+
162	17	S2	0	3946.701	40262.966	0	12863.555	9.999+	9.999+
163	17	S3	0	4272.549	40282.612	0	12978.252	9.428	9.999+
164	17	S4	0	3976.487	40288.175	0	12993.661	9.999+	9.999+
165	17	S5	0	4023.32	40270.684	0	12966.981	9.999+	9.999+
166	17	S6	0	4060.052	40269.925	0	12947.255	9.919	9.999+
167	17	S7	0	3934.811	40287.106	0	12985.391	9.999+	9.999+
168	17	S8	0	4298.026	40284.427	0	13000.937	9.373	9.999+
169	17	S9	0	3956.799	40263.505	0	12859.589	9.999+	9.999+
170	17	S10	0	3704.684	40242.648	0	12840.133	9.999+	9.999+
171	18	S1	0	16679.575	40331.612	2257.27	10337.958	2.418	4.58



Slab Overturning Safety Factors (By Combination) (Continued)

LC	Slab	Angle[deg]	Mo-xx[lb-ft]	Ms-xx[lb-ft]	Mo-zz[lb-ft]	Ms-zz[lb-ft]	Ms-xx/Mo-xx	Ms-zz/Mo-zz	
172	18	S2	0	16715.02	40246.869	2190.833	10321.756	2.408	4.711
173	18	S3	0	17418.711	40286.679	2267.384	10329.379	2.313	4.556
174	18	S4	0	17257.795	40291.025	2266.032	10330.649	2.335	4.559
175	18	S5	0	17144.565	40276.863	2249.757	10326.591	2.349	4.59
176	18	S6	0	17160.231	40276.174	2247.571	10326.405	2.347	4.594
177	18	S7	0	17224.855	40290.172	2267.724	10330.403	2.339	4.555
178	18	S8	0	17446.665	40288.125	2270.44	10329.797	2.309	4.55
179	18	S9	0	16728.204	40247.329	2191.876	10321.884	2.406	4.709
180	18	S10	0	16654.994	40329.897	2255.977	10337.541	2.421	4.582
181	19	S1	0	1371.113	40244.63	0	11377.236	9.999+	9.999+
182	19	S2	0	1280.954	40262.966	0	11124.96	9.999+	9.999+
183	19	S3	0	1079.555	40282.612	0	11065.772	9.999+	9.999+
184	19	S4	0	743.788	40288.175	0	10823.629	9.999+	9.999+
185	19	S5	0	548.037	40270.684	0	10677.79	9.999+	9.999+
186	19	S6	0	526.537	40269.925	0	10699.8	9.999+	9.999+
187	19	S7	0	536.537	40287.106	0	10702.482	9.999+	9.999+
188	19	S8	0	573.888	40284.427	0	10705.04	9.999+	9.999+
189	19	S9	0	549.366	40263.505	0	10668.976	9.999+	9.999+
190	19	S10	0	501.521	40242.648	0	10678.546	9.999+	9.999+
191	20	S1	0	9262.419	40331.612	1053.73	10337.958	4.354	9.811
192	20	S2	0	6936.356	40246.869	748.77	10321.756	5.802	9.999+
193	20	S3	0	5715.126	40286.679	603.664	10329.379	7.049	9.999+
194	20	S4	0	6051.435	40291.025	662.368	10330.649	6.658	9.999+
195	20	S5	0	6126.843	40276.863	660.864	10326.591	6.574	9.999+
196	20	S6	0	6150.939	40276.174	662.204	10326.405	6.548	9.999+
197	20	S7	0	6165.057	40290.172	668.388	10330.403	6.535	9.999+
198	20	S8	0	6263.137	40288.125	673.27	10329.797	6.433	9.999+
199	20	S9	0	5904.083	40247.329	632.288	10321.884	6.817	9.999+
200	20	S10	0	6090.533	40329.897	693.725	10337.541	6.622	9.999+

Slab Sliding Safety Factors (By Combination)

LC	Slab	Angle[deg]	Va-xx[lb]	Vr-xx[lb]	Va-zz[lb]	Vr-zz[lb]	SR-xx	SR-zz	
1	1	S1	0	3.417	2754.739	0	2754.739	9.999+	9.999+
2	1	S2	0	0	2752.468	0	2752.468	9.999+	9.999+
3	1	S3	0	0	2754.501	0	2754.501	9.999+	9.999+
4	1	S4	0	0	2754.84	0	2754.84	9.999+	9.999+
5	1	S5	0	0	2753.758	0	2753.758	9.999+	9.999+
6	1	S6	0	0	2753.708	0	2753.708	9.999+	9.999+
7	1	S7	0	0	2754.774	0	2754.774	9.999+	9.999+
8	1	S8	0	0	2754.612	0	2754.612	9.999+	9.999+
9	1	S9	0	0	2752.502	0	2752.502	9.999+	9.999+
10	1	S10	0	3.442	2754.612	0	2754.612	9.999+	9.999+
11	2	S1	0	13.346	2972.984	0	2972.984	9.999+	9.999+
12	2	S2	0	0	2969.081	0	2969.081	9.999+	9.999+
13	2	S3	0	0	2978.138	0	2978.138	9.999+	9.999+
14	2	S4	0	0	2979.138	0	2979.138	9.999+	9.999+
15	2	S5	0	1.731	2975.164	0	2975.164	9.999+	9.999+
16	2	S6	0	1.641	2975.005	0	2975.005	9.999+	9.999+
17	2	S7	0	0	2978.895	0	2978.895	9.999+	9.999+
18	2	S8	0	0	2978.542	0	2978.542	9.999+	9.999+
19	2	S9	0	0	2969.161	0	2969.161	9.999+	9.999+
20	2	S10	0	13.457	2972.692	0	2972.692	9.999+	9.999+
21	3	S1	0	28.567	2225.456	1194.848	2225.456	9.999+	1.863
22	3	S2	0	1.113	2238.948	1233.868	2238.948	9.999+	1.815
23	3	S3	0	3.252	2217.003	1263.903	2217.003	9.999+	1.754
24	3	S4	0	0	2216.934	1249.135	2216.934	9.999+	1.775



Company : Vector Structural Engineering
 Designer : STB
 Job Number : U2716.092.181
 Model Name : Ground Mount

Apr 12, 2021
 3:56 PM
 Checked By: JSP

Slab Sliding Safety Factors (By Combination) (Continued)

	LC	Slab	Angle[deg]	Va-xx[lb]	Vr-xx[lb]	Va-zz[lb]	Vr-zz[lb]	SR-xx	SR-zz
25	3	S5	0	3.35	2221.869	1242.922	2221.869	9.999+	1.788
26	3	S6	0	2.982	2222.055	1244.932	2222.055	9.999+	1.785
27	3	S7	0	1.072	2217.278	1245.772	2217.278	9.999+	1.78
28	3	S8	0	3.306	2216.527	1266.52	2216.527	9.999+	1.75
29	3	S9	0	0	2238.585	1234.964	2238.585	9.999+	1.813
30	3	S10	0	29.086	2225.966	1193.041	2225.966	9.999+	1.866
31	4	S1	0	35.138	2287.839	1038.503	2287.839	9.999+	2.203
32	4	S2	0	1.421	2315.078	1065.244	2315.078	9.999+	2.173
33	4	S3	0	2.364	2286.895	1102.661	2286.895	9.999+	2.074
34	4	S4	0	.793	2288.596	1083.961	2288.596	9.999+	2.111
35	4	S5	0	.708	2291.582	1077.868	2291.582	9.999+	2.126
36	4	S6	0	.425	2291.683	1080.413	2291.683	9.999+	2.121
37	4	S7	0	.738	2288.864	1079.863	2288.864	9.999+	2.12
38	4	S8	0	2.398	2286.611	1105.802	2286.611	9.999+	2.068
39	4	S9	0	1.148	2314.591	1066.497	2314.591	9.999+	2.17
40	4	S10	0	35.462	2288.398	1036.416	2288.398	9.999+	2.208
41	5	S1	0	41.798	3383.259	1418.305	3383.259	9.999+	2.385
42	5	S2	0	1.338	3361.697	1464.359	3361.697	9.999+	2.296
43	5	S3	0	3.843	3392.536	1500.428	3392.536	9.999+	2.261
44	5	S4	0	1.111	3393.296	1482.681	3393.296	9.999+	2.289
45	5	S5	0	3.895	3385.114	1475.282	3385.114	9.999+	2.295
46	5	S6	0	3.46	3384.788	1477.697	3384.788	9.999+	2.291
47	5	S7	0	1.289	3392.745	1478.647	3392.745	9.999+	2.294
48	5	S8	0	3.907	3393.342	1503.566	3393.342	9.999+	2.257
49	5	S9	0	1.096	3362.209	1465.671	3362.209	9.999+	2.294
50	5	S10	0	42.476	3382.372	1416.141	3382.372	9.999+	2.388
51	6	S1	0	19.209	2226.569	1205.619	2226.569	9.999+	1.847
52	6	S2	0	0	2226.668	1251.133	2226.668	9.999+	1.78
53	6	S3	0	3.677	2212.535	1271.753	2212.535	9.999+	1.74
54	6	S4	0	0	2210.992	1261.872	2210.992	9.999+	1.752
55	6	S5	0	5.266	2216.976	1256.197	2216.976	9.999+	1.765
56	6	S6	0	4.864	2217.209	1257.542	2217.209	9.999+	1.763
57	6	S7	0	1.398	2211.359	1259.486	2211.359	9.999+	1.756
58	6	S8	0	3.744	2211.953	1273.652	2211.953	9.999+	1.737
59	6	S9	0	0	2226.452	1251.981	2226.452	9.999+	1.778
60	6	S10	0	19.549	2226.973	1204.237	2226.973	9.999+	1.849
61	7	S1	0	18.344	2995.209	543.407	2995.209	9.999+	5.512
62	7	S2	0	1.857	2946.351	473.031	2946.351	9.999+	6.229
63	7	S3	0	0	2931.235	409.794	2931.235	9.999+	7.153
64	7	S4	0	2.725	2874.79	280.081	2874.79	9.999+	9.999+
65	7	S5	0	0	2838.045	199.366	2838.045	9.999+	9.999+
66	7	S6	0	0	2843.323	206.882	2843.323	9.999+	9.999+
67	7	S7	0	0	2844.073	207.796	2844.073	9.999+	9.999+
68	7	S8	0	0	2844.671	210.677	2844.671	9.999+	9.999+
69	7	S9	0	0	2835.804	206.105	2835.804	9.999+	9.999+
70	7	S10	0	11.38	2844.934	198.849	2844.934	9.999+	9.999+
71	8	S1	0	13.398	2511.932	546.579	2511.932	9.999+	4.596
72	8	S2	0	2.928	2574.52	433.608	2574.52	9.999+	5.937
73	8	S3	0	0	2609.621	345.985	2609.621	9.999+	7.543
74	8	S4	0	1.017	2596.481	362.888	2596.481	9.999+	7.155
75	8	S5	0	0	2595.15	370.776	2595.15	9.999+	6.999
76	8	S6	0	0	2594.779	372.355	2594.779	9.999+	6.969
77	8	S7	0	0	2594.361	372.009	2594.361	9.999+	6.974
78	8	S8	0	1.077	2593.674	377.645	2593.674	9.999+	6.868
79	8	S9	0	0	2600.753	369.148	2600.753	9.999+	7.045
80	8	S10	0	8.273	2595.148	356.332	2595.148	9.999+	7.283
81	9	S1	0	13.125	2521.46	896.136	2521.46	9.999+	2.814



Slab Sliding Safety Factors (By Combination) (Continued)

	LC	Slab	Angle[deg]	Va-xx[lb]	Vr-xx[lb]	Va-zz[lb]	Vr-zz[lb]	SR-xx	SR-zz
82	9	S2	0	.835	2529.788	925.401	2529.788	9.999+	2.734
83	9	S3	0	2.439	2519.106	947.927	2519.106	9.999+	2.657
84	9	S4	0	0	2519.634	936.851	2519.634	9.999+	2.689
85	9	S5	0	1.214	2520.896	932.192	2520.896	9.999+	2.704
86	9	S6	0	1.005	2520.94	933.699	2520.94	9.999+	2.7
87	9	S7	0	.804	2519.743	934.329	2519.743	9.999+	2.697
88	9	S8	0	2.48	2518.995	949.89	2518.995	9.999+	2.652
89	9	S9	0	0	2529.558	926.223	2529.558	9.999+	2.731
90	9	S10	0	13.443	2521.687	894.78	2521.687	9.999+	2.818
91	10	S1	0	18.053	2568.248	778.877	2568.248	9.999+	3.297
92	10	S2	0	1.066	2586.885	798.933	2586.885	9.999+	3.238
93	10	S3	0	1.773	2571.524	826.996	2571.524	9.999+	3.109
94	10	S4	0	.595	2573.38	812.971	2573.38	9.999+	3.165
95	10	S5	0	.767	2573.181	808.401	2573.181	9.999+	3.183
96	10	S6	0	.912	2573.162	810.31	2573.162	9.999+	3.176
97	10	S7	0	.553	2573.432	809.897	2573.432	9.999+	3.177
98	10	S8	0	1.799	2571.559	829.352	2571.559	9.999+	3.101
99	10	S9	0	.861	2586.563	799.872	2586.563	9.999+	3.234
100	10	S10	0	18.225	2568.511	777.312	2568.511	9.999+	3.304
101	11	S1	0	39.649	3389.813	1063.729	3389.813	9.999+	3.187
102	11	S2	0	1.004	3371.85	1098.269	3371.85	9.999+	3.07
103	11	S3	0	2.882	3400.755	1125.321	3400.755	9.999+	3.022
104	11	S4	0	.833	3401.906	1112.011	3401.906	9.999+	3.059
105	11	S5	0	4.219	3393.33	1106.461	3393.33	9.999+	3.067
106	11	S6	0	3.826	3392.99	1108.273	3392.99	9.999+	3.062
107	11	S7	0	.967	3401.343	1108.985	3401.343	9.999+	3.067
108	11	S8	0	2.93	3401.606	1127.674	3401.606	9.999+	3.016
109	11	S9	0	.822	3372.276	1099.254	3372.276	9.999+	3.068
110	11	S10	0	40.229	3388.992	1062.106	3388.992	9.999+	3.191
111	12	S1	0	6.106	2522.296	904.214	2522.296	9.999+	2.789
112	12	S2	0	0	2520.578	938.35	2520.578	9.999+	2.686
113	12	S3	0	2.757	2515.754	953.815	2515.754	9.999+	2.638
114	12	S4	0	0	2515.178	946.404	2515.178	9.999+	2.658
115	12	S5	0	2.652	2517.226	942.148	2517.226	9.999+	2.672
116	12	S6	0	2.417	2517.306	943.156	2517.306	9.999+	2.669
117	12	S7	0	1.049	2515.304	944.614	2515.304	9.999+	2.663
118	12	S8	0	2.808	2515.565	955.239	2515.565	9.999+	2.633
119	12	S9	0	0	2520.458	938.986	2520.458	9.999+	2.684
120	12	S10	0	6.291	2522.442	903.178	2522.442	9.999+	2.793
121	13	S1	0	22.058	3098.775	407.555	3098.775	9.999+	7.603
122	13	S2	0	1.393	3060.34	354.773	3060.34	9.999+	8.626
123	13	S3	0	0	3054.78	307.346	3054.78	9.999+	9.939
124	13	S4	0	2.044	3013.026	210.061	3013.026	9.999+	9.999+
125	13	S5	0	1.298	2983.028	149.524	2983.028	9.999+	9.999+
126	13	S6	0	1.231	2986.892	155.162	2986.892	9.999+	9.999+
127	13	S7	0	0	2989.839	155.847	2989.839	9.999+	9.999+
128	13	S8	0	0	2990.103	158.008	2990.103	9.999+	9.999+
129	13	S9	0	0	2977.473	154.578	2977.473	9.999+	9.999+
130	13	S10	0	16.907	2985.913	149.137	2985.913	9.999+	9.999+
131	14	S1	0	1.748	2736.318	409.934	2736.318	9.999+	6.675
132	14	S2	0	2.196	2781.467	325.206	2781.467	9.999+	8.553
133	14	S3	0	0	2813.569	259.489	2813.569	9.999+	9.999+
134	14	S4	0	.762	2804.295	272.166	2804.295	9.999+	9.999+
135	14	S5	0	1.298	2800.857	278.082	2800.857	9.999+	9.999+
136	14	S6	0	1.231	2800.484	279.266	2800.484	9.999+	9.999+
137	14	S7	0	0	2802.555	279.006	2802.555	9.999+	9.999+
138	14	S8	0	.808	2801.856	283.233	2801.856	9.999+	9.892



Slab Sliding Safety Factors (By Combination) (Continued)

	LC	Slab	Angle[deg]	Va-xx[lb]	Vr-xx[lb]	Va-zz[lb]	Vr-zz[lb]	SR-xx	SR-zz
139	14	S9	0	0	2801.184	276.861	2801.184	9.999+	9.999+
140	14	S10	0	2.167	2798.573	267.249	2798.573	9.999+	9.999+
141	15	S1	0	28.909	1949.982	1194.848	1949.982	9.999+	1.632
142	15	S2	0	1.113	1963.701	1233.868	1963.701	9.999+	1.592
143	15	S3	0	3.252	1941.553	1263.903	1941.553	9.999+	1.536
144	15	S4	0	0	1941.45	1249.135	1941.45	9.999+	1.554
145	15	S5	0	3.35	1946.494	1242.922	1946.494	9.999+	1.566
146	15	S6	0	2.982	1946.684	1244.932	1946.684	9.999+	1.564
147	15	S7	0	1.072	1941.801	1245.772	1941.801	9.999+	1.559
148	15	S8	0	3.306	1941.065	1266.52	1941.065	9.999+	1.533
149	15	S9	0	0	1963.335	1234.964	1963.335	9.999+	1.59
150	15	S10	0	29.43	1950.505	1193.041	1950.505	9.999+	1.635
151	16	S1	0	35.479	2012.365	1038.503	2012.365	9.999+	1.938
152	16	S2	0	1.421	2039.831	1065.244	2039.831	9.999+	1.915
153	16	S3	0	2.364	2011.445	1102.661	2011.445	9.999+	1.824
154	16	S4	0	.793	2013.112	1083.961	2013.112	9.999+	1.857
155	16	S5	0	.708	2016.207	1077.868	2016.207	9.999+	1.871
156	16	S6	0	.425	2016.312	1080.413	2016.312	9.999+	1.866
157	16	S7	0	.738	2013.386	1079.863	2013.386	9.999+	1.864
158	16	S8	0	2.398	2011.15	1105.802	2011.15	9.999+	1.819
159	16	S9	0	1.148	2039.341	1066.497	2039.341	9.999+	1.912
160	16	S10	0	35.807	2012.936	1036.416	2012.936	9.999+	1.942
161	17	S1	0	41.456	3107.786	1418.305	3107.786	9.999+	2.191
162	17	S2	0	1.338	3086.45	1464.359	3086.45	9.999+	2.108
163	17	S3	0	3.843	3117.086	1500.428	3117.086	9.999+	2.077
164	17	S4	0	1.111	3117.812	1482.681	3117.812	9.999+	2.103
165	17	S5	0	3.895	3109.738	1475.282	3109.738	9.999+	2.108
166	17	S6	0	3.46	3109.417	1477.697	3109.417	9.999+	2.104
167	17	S7	0	1.289	3117.267	1478.647	3117.267	9.999+	2.108
168	17	S8	0	3.907	3117.881	1503.566	3117.881	9.999+	2.074
169	17	S9	0	1.096	3086.959	1465.671	3086.959	9.999+	2.106
170	17	S10	0	42.132	3106.911	1416.141	3106.911	9.999+	2.194
171	18	S1	0	19.55	1951.096	1205.619	1951.096	9.999+	1.618
172	18	S2	0	0	1951.421	1251.133	1951.421	9.999+	1.56
173	18	S3	0	3.677	1937.085	1271.753	1937.085	9.999+	1.523
174	18	S4	0	0	1935.508	1261.872	1935.508	9.999+	1.534
175	18	S5	0	5.266	1941.6	1256.197	1941.6	9.999+	1.546
176	18	S6	0	4.864	1941.838	1257.542	1941.838	9.999+	1.544
177	18	S7	0	1.398	1935.882	1259.486	1935.882	9.999+	1.537
178	18	S8	0	3.744	1936.492	1273.652	1936.492	9.999+	1.52
179	18	S9	0	0	1951.202	1251.981	1951.202	9.999+	1.558
180	18	S10	0	19.894	1951.512	1204.237	1951.512	9.999+	1.621
181	19	S1	0	18.002	2719.735	543.407	2719.735	9.999+	5.005
182	19	S2	0	1.857	2671.104	473.031	2671.104	9.999+	5.647
183	19	S3	0	0	2655.785	409.794	2655.785	9.999+	6.481
184	19	S4	0	2.725	2599.306	280.081	2599.306	9.999+	9.281
185	19	S5	0	0	2562.67	199.366	2562.67	9.999+	9.999+
186	19	S6	0	0	2567.952	206.882	2567.952	9.999+	9.999+
187	19	S7	0	0	2568.596	207.796	2568.596	9.999+	9.999+
188	19	S8	0	0	2569.21	210.677	2569.21	9.999+	9.999+
189	19	S9	0	0	2560.554	206.105	2560.554	9.999+	9.999+
190	19	S10	0	11.036	2569.473	198.849	2569.473	9.999+	9.999+
191	20	S1	0	13.739	2236.458	546.579	2236.458	9.999+	4.092
192	20	S2	0	2.928	2299.273	433.608	2299.273	9.999+	5.303
193	20	S3	0	0	2334.171	345.985	2334.171	9.999+	6.746
194	20	S4	0	1.017	2320.997	362.888	2320.997	9.999+	6.396
195	20	S5	0	0	2319.774	370.776	2319.774	9.999+	6.257



Company : Vector Structural Engineering
 Designer : STB
 Job Number : U2716.092.181
 Model Name : Ground Mount

Apr 12, 2021
 3:56 PM
 Checked By: JSP

Slab Sliding Safety Factors (By Combination) (Continued)

	LC	Slab	Angle[deg]	Va-xx[lb]	Vr-xx[lb]	Va-zz[lb]	Vr-zz[lb]	SR-xx	SR-zz
196	20	S6	0	0	2319.408	372.355	2319.408	9.999+	6.229
197	20	S7	0	0	2318.883	372.009	2318.883	9.999+	6.233
198	20	S8	0	1.077	2318.213	377.645	2318.213	9.999+	6.139
199	20	S9	0	0	2325.503	369.148	2325.503	9.999+	6.3
200	20	S10	0	8.618	2319.686	356.332	2319.686	9.999+	6.51

Envelope Slab Soil Pressures

	Label	UC	LC	Soil Pressure[psf]	Allowable Bearing[psf]	Point
1	S1	.481	5	721.511	1500	N282
2	S2	.475	5	712.06	1500	N289
3	S3	.489	5	733.993	1500	N296
4	S4	.485	5	728.021	1500	N303
5	S5	.484	5	725.704	1500	N310
6	S6	.484	5	726.308	1500	N317
7	S7	.485	5	726.971	1500	N324
8	S8	.49	5	734.814	1500	N331
9	S9	.475	5	712.49	1500	N338
10	S10	.481	5	720.769	1500	N345



Company:		Date:	5/14/2018
Engineer:		Page:	1/6
Project:			
Address:			
Phone:			
E-mail:			

1. Project information

Customer company:
Customer contact name:
Customer e-mail:
Comment:

Project description:
Location:
Fastening description:

2. Input Data & Anchor Parameters

General

Design method: ACI 318-05
Units: Imperial units

Anchor Information:

Anchor type: Bonded anchor
Material: F1554 Grade 36
Diameter (inch): 0.375
Effective Embedment depth, h_{ef} (inch): 5.000
Code report: ICC-ES ESR-4057
Anchor category: -
Anchor ductility: Yes
 h_{min} (inch): 6.25
 c_{ac} (inch): 9.16
 C_{min} (inch): 1.75
 S_{min} (inch): 3.00

Base Material

Concrete: Normal-weight
Concrete thickness, h (inch): 30.00
State: Cracked
Compressive strength, f'_c (psi): 2500
 $\Psi_{c,v}$: 1.0
Reinforcement condition: B tension, B shear
Supplemental reinforcement: Not applicable
Reinforcement provided at corners: No
Ignore concrete breakout in tension: No
Ignore concrete breakout in shear: No
Hole condition: Dry concrete
Inspection: Periodic
Temperature range, Short/Long: 150/110°F
Ignore 6do requirement: Not applicable
Build-up grout pad: No

Base Plate

Length x Width x Thickness (inch): 4.75 x 4.75 x 0.31
Yield stress: 34084 psi

Profile type/size: Pipe1-1/2STD

Recommended Anchor

Anchor Name: SET-3G - SET-3G w/ 3/8"Ø F1554 Gr. 36
Code Report: ICC-ES ESR-4057





Company:		Date:	5/14/2018
Engineer:		Page:	2/6
Project:			
Address:			
Phone:			
E-mail:			

Load and Geometry

Load factor source: ACI 318 Section 9.2

Load combination: not set

Seismic design: No

Anchors subjected to sustained tension: No

Apply entire shear load at front row: No

Anchors only resisting wind and/or seismic loads: No

Strength level loads:

N_{ua} [lb]: 3829

V_{uax} [lb]: 230

V_{uay} [lb]: -2667

M_{ux} [ft-lb]: 0

M_{uy} [ft-lb]: 0

M_{uz} [ft-lb]: 0

<Figure 1>

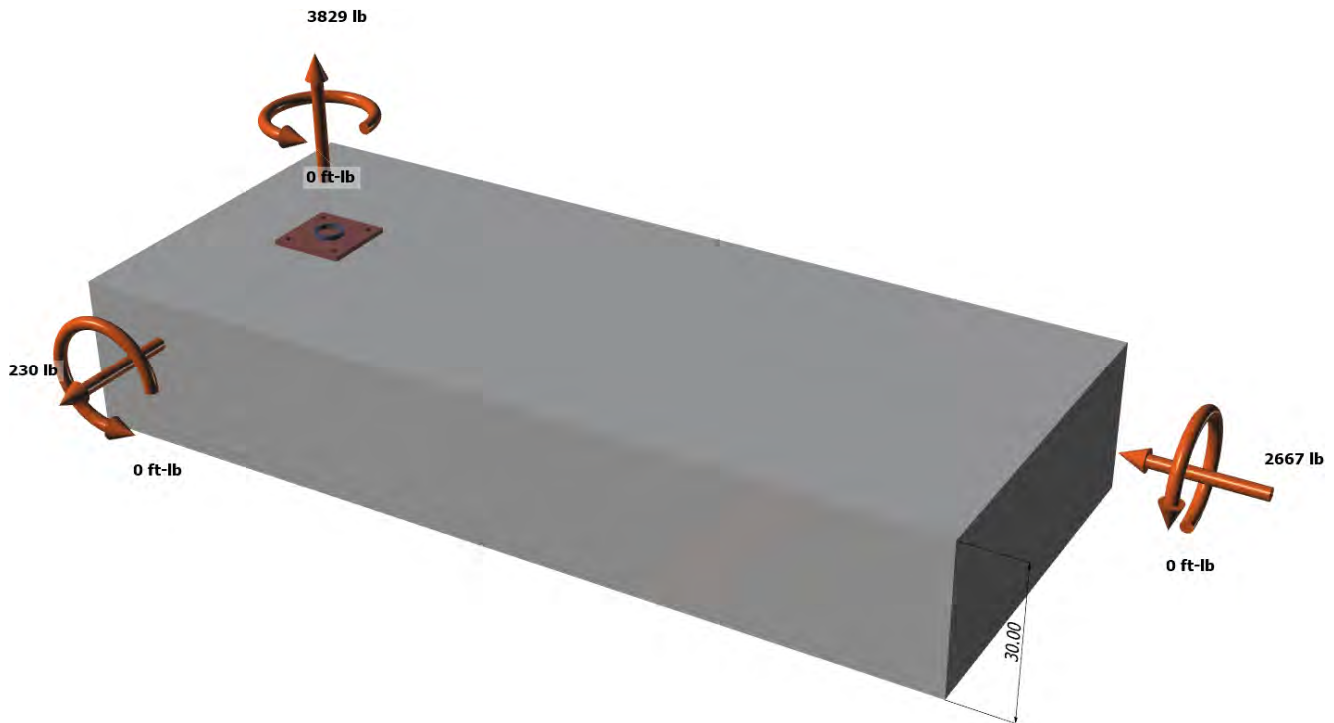



Company:		Date:	5/14/2018
Engineer:		Page:	3/6
Project:			
Address:			
Phone:			
E-mail:			

<Figure 2>

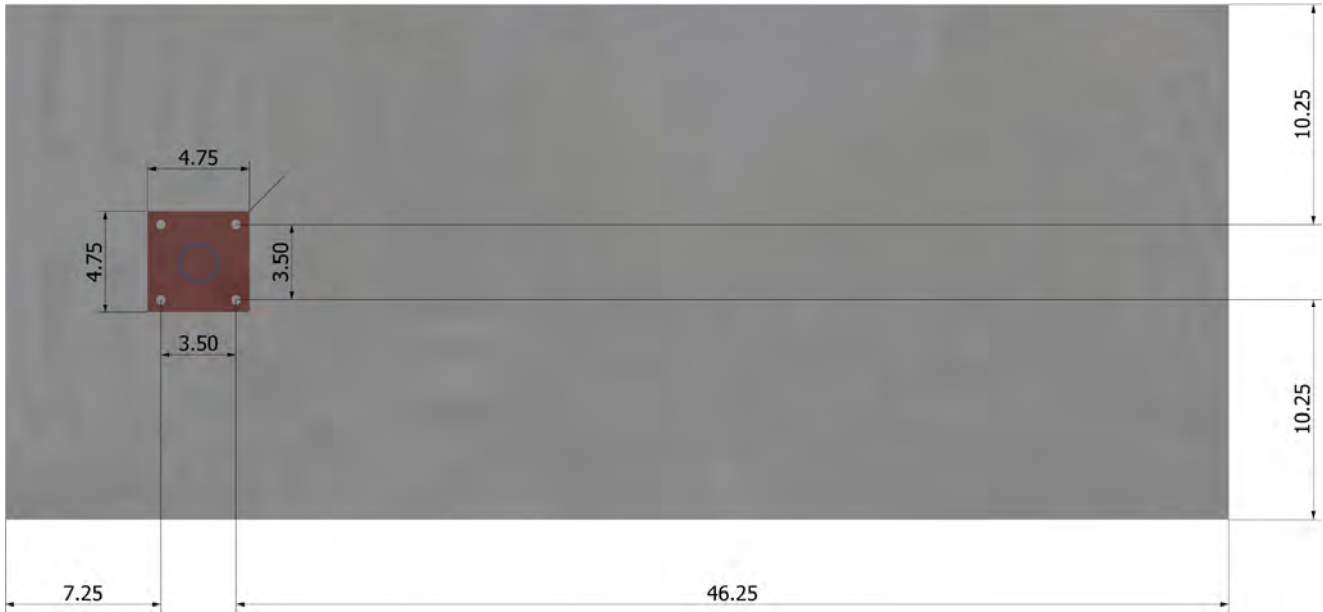



Company:		Date:	5/14/2018
Engineer:		Page:	4/6
Project:			
Address:			
Phone:			
E-mail:			

3. Resulting Anchor Forces

Anchor	Tension load, N _{ua} (lb)	Shear load x, V _{uax} (lb)	Shear load y, V _{uay} (lb)	Shear load combined, $\sqrt{(V_{uax})^2 + (V_{uay})^2}$ (lb)
1	957.3	57.5	-666.8	669.2
2	957.3	57.5	-666.8	669.2
3	957.3	57.5	-666.8	669.2
4	957.3	57.5	-666.8	669.2
Sum	3829.0	230.0	-2667.0	2676.9

Maximum concrete compression strain (%): 0.00
 Maximum concrete compression stress (psi): 0
 Resultant tension force (lb): 3829
 Resultant compression force (lb): 0
 Eccentricity of resultant tension forces in x-axis, e'_{Nx} (inch): 0.00
 Eccentricity of resultant tension forces in y-axis, e'_{Ny} (inch): 0.00
 Eccentricity of resultant shear forces in x-axis, e'_{Vx} (inch): 0.00
 Eccentricity of resultant shear forces in y-axis, e'_{Vy} (inch): 0.00

<Figure 3>

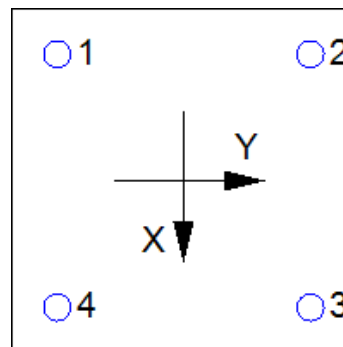

4. Steel Strength of Anchor in Tension (Sec. D.5.1)

N _{sa} (lb)	φ	φN _{sa} (lb)
4525	0.75	3394

5. Concrete Breakout Strength of Anchor in Tension (Sec. D.5.2)

$$N_b = k_c \lambda \sqrt{f_c} h_{ef}^{1.5} \text{ (Eq. D-7)}$$

k _c	λ	f _c (psi)	h _{ef} (in)	N _b (lb)
17.0	1.00	2500	5.000	9503

$$\phi N_{cbg} = \phi (A_{Nc} / A_{Nco}) \Psi_{ec,N} \Psi_{ed,N} \Psi_{c,N} \Psi_{cp,N} N_b \text{ (Sec. D.4.1 \& Eq. D-5)}$$

A _{Nc} (in ²)	A _{Nco} (in ²)	c _{a,min} (in)	Ψ _{ec,N}	Ψ _{ed,N}	Ψ _{c,N}	Ψ _{cp,N}	N _b (lb)	φ	φN _{cbg} (lb)
337.63	225.00	7.25	1.000	0.990	1.00	1.000	9503	0.65	9176

6. Adhesive Strength of Anchor in Tension (AC308 Sec. 3.3)

$$\tau_{k,cr} = \tau_{k,cr,short-term} K_{sat} (f_c / 2,500)^n$$

τ _{k,cr} (psi)	f _{short-term}	K _{sat}	f _c (psi)	n	τ _{k,cr} (psi)
1346	1.00	1.00	2500	0.24	1346

$$N_{a0} = \tau_{k,cr} \pi d_a h_{ef} \text{ (Eq. D-16f)}$$

τ _{k,cr} (psi)	d _a (in)	h _{ef} (in)	N _{a0} (lb)
1346	0.38	5.000	7929

$$\phi N_{ag} = \phi (A_{Na} / A_{Na0}) \Psi_{ed,Na} \Psi_{g,Na} \Psi_{ec,Na} \Psi_{p,Na} N_{a0} \text{ (Sec. D.4.1 \& Eq. D-16b)}$$

A _{Na} (in ²)	A _{Na0} (in ²)	Ψ _{ed,Na}	Ψ _{g,Na}	Ψ _{ec,Na}	Ψ _{p,Na}	N _{a0} (lb)	φ	φN _{ag} (lb)
161.83	85.03	1.000	1.091	1.000	1.000	7929	0.55	9057

Input data and results must be checked for agreement with the existing circumstances, the standards and guidelines must be checked for plausibility.



Company:		Date:	5/14/2018
Engineer:		Page:	5/6
Project:			
Address:			
Phone:			
E-mail:			

8. Steel Strength of Anchor in Shear (Sec. D.6.1)

V_{sa} (lb)	ϕ_{grout}	ϕ	$\phi_{grout}\phi V_{sa}$ (lb)
2715	1.0	0.65	1765

9. Concrete Breakout Strength of Anchor in Shear (Sec. D.6.2)

Shear perpendicular to edge in x-direction:

$$V_{bx} = 7(l_e / d_a)^{0.2} \sqrt{d_a} \lambda \sqrt{f_c} c_{a1}^{1.5} \text{ (Eq. D-24)}$$

l_e (in)	d_a (in)	λ	f_c (psi)	c_{a1} (in)	V_{bx} (lb)
3.00	0.375	1.00	2500	13.75	16564

$$\phi V_{cbgx} = \phi (A_{vc} / A_{vco}) \Psi_{ec,v} \Psi_{ed,v} \Psi_{c,v} \Psi_{h,v} V_{bx} \text{ (Sec. D.4.1 \& Eq. D-22)}$$

A_{vc} (in ²)	A_{vco} (in ²)	$\Psi_{ec,v}$	$\Psi_{ed,v}$	$\Psi_{c,v}$	$\Psi_{h,v}$	V_{bx} (lb)	ϕ	ϕV_{cbgx} (lb)
647.11	850.78	1.000	0.805	1.000	1.000	16564	0.70	7103

Shear perpendicular to edge in y-direction:

$$V_{by} = 7(l_e / d_a)^{0.2} \sqrt{d_a} \lambda \sqrt{f_c} c_{a1}^{1.5} \text{ (Eq. D-24)}$$

l_e (in)	d_a (in)	λ	f_c (psi)	c_{a1} (in)	V_{by} (lb)
3.00	0.375	1.00	2500	10.75	11450

$$\phi V_{cbgy} = \phi (A_{vc} / A_{vco}) \Psi_{ec,v} \Psi_{ed,v} \Psi_{c,v} \Psi_{h,v} V_{by} \text{ (Sec. D.4.1 \& Eq. D-22)}$$

A_{vc} (in ²)	A_{vco} (in ²)	$\Psi_{ec,v}$	$\Psi_{ed,v}$	$\Psi_{c,v}$	$\Psi_{h,v}$	V_{by} (lb)	ϕ	ϕV_{cbgy} (lb)
387.00	520.03	1.000	0.891	1.000	1.000	11450	0.70	5313

Shear parallel to edge in x-direction:

$$V_{by} = 7(l_e / d_a)^{0.2} \sqrt{d_a} \lambda \sqrt{f_c} c_{a1}^{1.5} \text{ (Eq. D-24)}$$

l_e (in)	d_a (in)	λ	f_c (psi)	c_{a1} (in)	V_{by} (lb)
3.00	0.375	1.00	2500	7.25	6342

$$\phi V_{cbgx} = \phi (2)(A_{vc} / A_{vco}) \Psi_{ec,v} \Psi_{ed,v} \Psi_{c,v} \Psi_{h,v} V_{by} \text{ (Sec. D.4.1, D.6.2.1(c) \& Eq. D-22)}$$

A_{vc} (in ²)	A_{vco} (in ²)	$\Psi_{ec,v}$	$\Psi_{ed,v}$	$\Psi_{c,v}$	$\Psi_{h,v}$	V_{by} (lb)	ϕ	ϕV_{cbgx} (lb)
261.00	236.53	1.000	1.000	1.000	1.000	6342	0.70	9797

Shear parallel to edge in y-direction:

$$V_{bx} = 7(l_e / d_a)^{0.2} \sqrt{d_a} \lambda \sqrt{f_c} c_{a1}^{1.5} \text{ (Eq. D-24)}$$

l_e (in)	d_a (in)	λ	f_c (psi)	c_{a1} (in)	V_{bx} (lb)
3.00	0.375	1.00	2500	10.25	10661

$$\phi V_{cbgy} = \phi (2)(A_{vc} / A_{vco}) \Psi_{ec,v} \Psi_{ed,v} \Psi_{c,v} \Psi_{h,v} V_{bx} \text{ (Sec. D.4.1, D.6.2.1(c) \& Eq. D-22)}$$

A_{vc} (in ²)	A_{vco} (in ²)	$\Psi_{ec,v}$	$\Psi_{ed,v}$	$\Psi_{c,v}$	$\Psi_{h,v}$	V_{bx} (lb)	ϕ	ϕV_{cbgy} (lb)
401.67	472.78	1.000	1.000	1.000	1.000	10661	0.70	12680

10. Concrete Pryout Strength of Anchor in Shear (Sec. D.6.3)

$$\phi V_{cp} = \phi \min[K_{cp} N_{ag}; K_{cp} N_{cbg}] = \phi \min[K_{cp}(A_{Na} / A_{Na0}) \Psi_{ed,Na} \Psi_{g,Na} \Psi_{ec,Na} \Psi_{p,Na} N_{a0}; K_{cp}(A_{Nc} / A_{Nco}) \Psi_{ec,N} \Psi_{ed,N} \Psi_{c,N} \Psi_{cp,N} N_b] \text{ (Eq. D-30b)}$$

K_{cp}	A_{Na} (in ²)	A_{Na0} (in ²)	$\Psi_{ed,Na}$	$\Psi_{g,Na}$	$\Psi_{ec,Na}$	$\Psi_{p,Na}$	N_{a0} (lb)	N_a (lb)
2.0	161.83	85.03	1.000	1.091	1.000	1.000	7929	16468

A_{Nc} (in ²)	A_{Nco} (in ²)	$\Psi_{ec,N}$	$\Psi_{ed,N}$	$\Psi_{c,N}$	$\Psi_{cp,N}$	N_b (lb)	N_{cb} (lb)	ϕ
337.63	225.00	1.000	0.990	1.000	1.000	9503	14118	0.70

Input data and results must be checked for agreement with the existing circumstances, the standards and guidelines must be checked for plausibility.



Company:		Date:	5/14/2018
Engineer:		Page:	6/6
Project:			
Address:			
Phone:			
E-mail:			

ϕV_{cpq} (lb)
19765

11. Results

Interaction of Tensile and Shear Forces (Sec. RD.7)

Tension	Factored Load, N_{ua} (lb)	Design Strength, ϕN_n (lb)	Ratio	Status	
Steel	957	3394	0.28	Pass	
Concrete breakout	3829	9176	0.42	Pass	
Adhesive	3829	9057	0.42	Pass (Governs)	
Shear	Factored Load, V_{ua} (lb)	Design Strength, ϕV_n (lb)	Ratio	Status	
Steel	669	1765	0.38	Pass	
T Concrete breakout x+	230	7103	0.03	Pass	
T Concrete breakout y-	2667	5313	0.50	Pass	
Concrete breakout y-	115	9797	0.01	Pass	
Concrete breakout x-	1334	12680	0.11	Pass	
Concrete breakout, combined	-	-	0.50	Pass (Governs)	
Pryout	2677	19765	0.14	Pass	
Interaction check	$(N_{ua}/\phi N_{ua})^{5/3}$	$(V_{ua}/\phi V_{ua})^{5/3}$	Combined Ratio	Permissible	Status
Sec. RD.7	0.24	0.32	55.6%	1.0	Pass

SET-3G w/ 3/8"Ø F1554 Gr. 36 with hef = 5.000 inch meets the selected design criteria.

12. Warnings

- Designer must exercise own judgement to determine if this design is suitable.
- Refer to manufacturer's product literature for hole cleaning and installation instructions.



JOB NO.: U2716-093-191

DESIGNED: STB

Framing Analysis

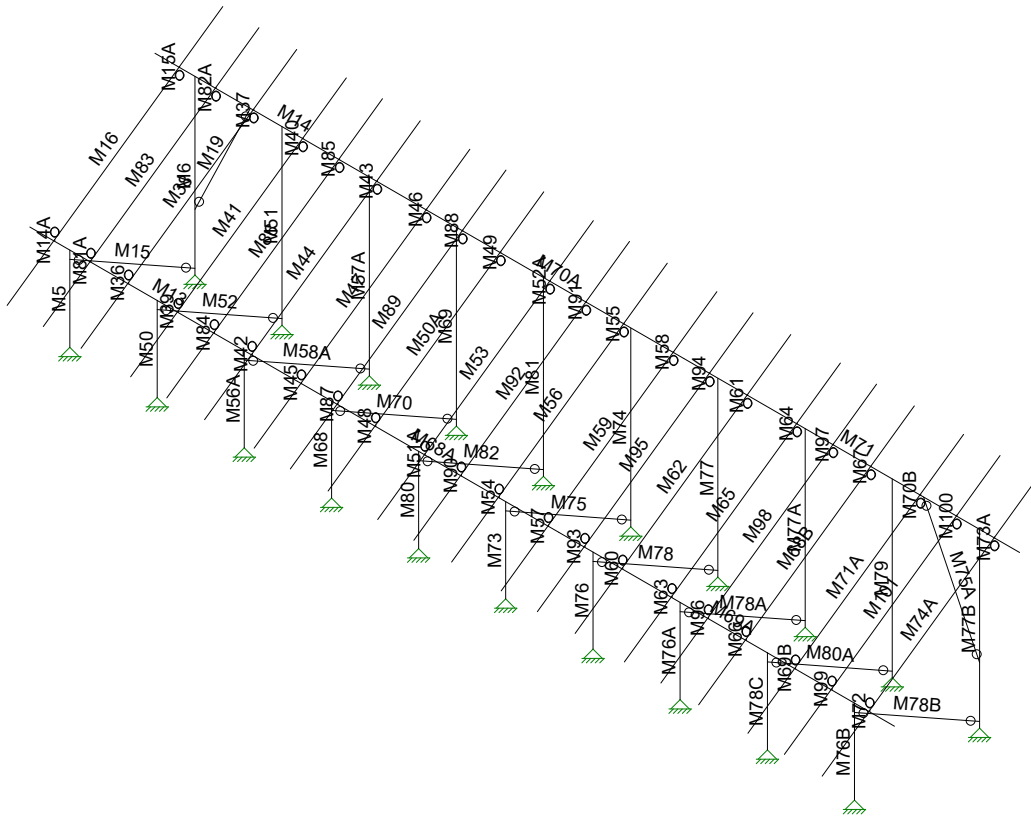

Vector Structural Engineeri...

STB

U2716.092.191

Ground Mount

SK - 3

Apr 12, 2021 at 3:37 PM

Sunmodo Sunturf A2 v5 85x45.r3d

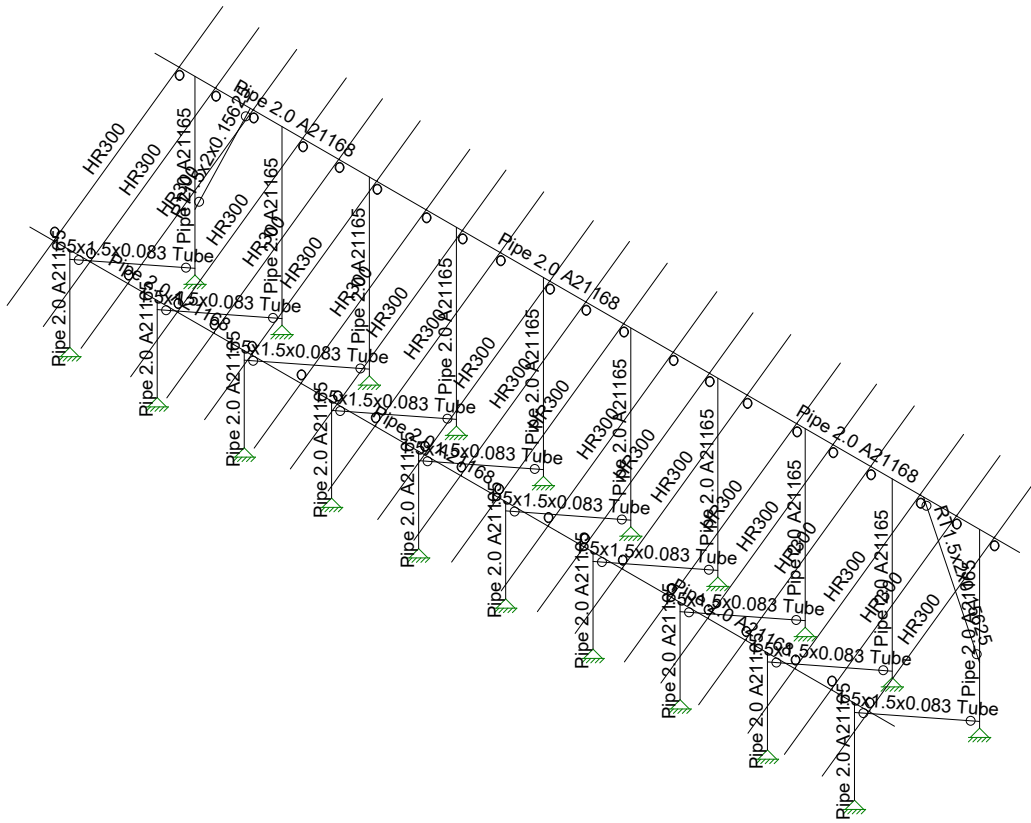

Vector Structural Engineeri...

STB

U2716.092.191

Ground Mount

SK - 4

Apr 12, 2021 at 3:37 PM

Sunmodo Sunturf A2 v5 85x45.r3d

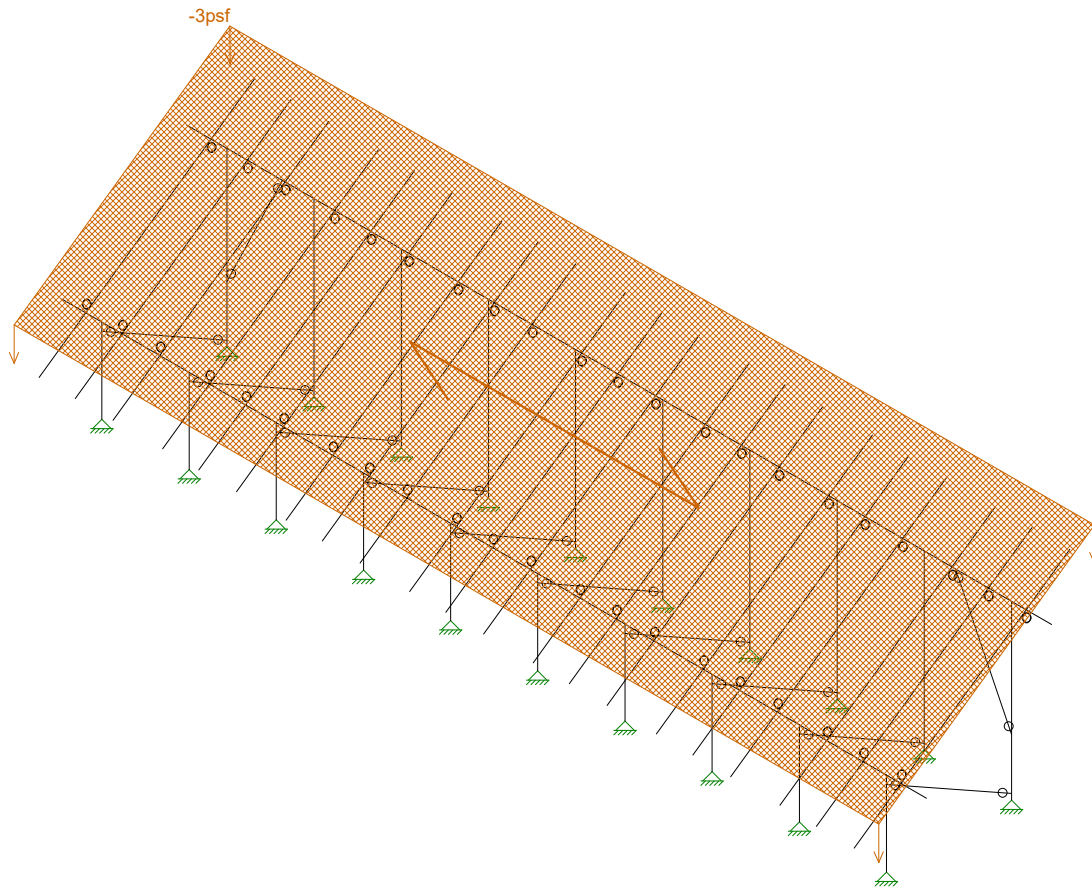

Loads: BLC 2, Solar Panel Weight

Vector Structural Engineeri...	Ground Mount	SK - 5
STB		Apr 12, 2021 at 3:37 PM
U2716.092.191		Sunmodo Sunturf A2 v5 85x45.r3d

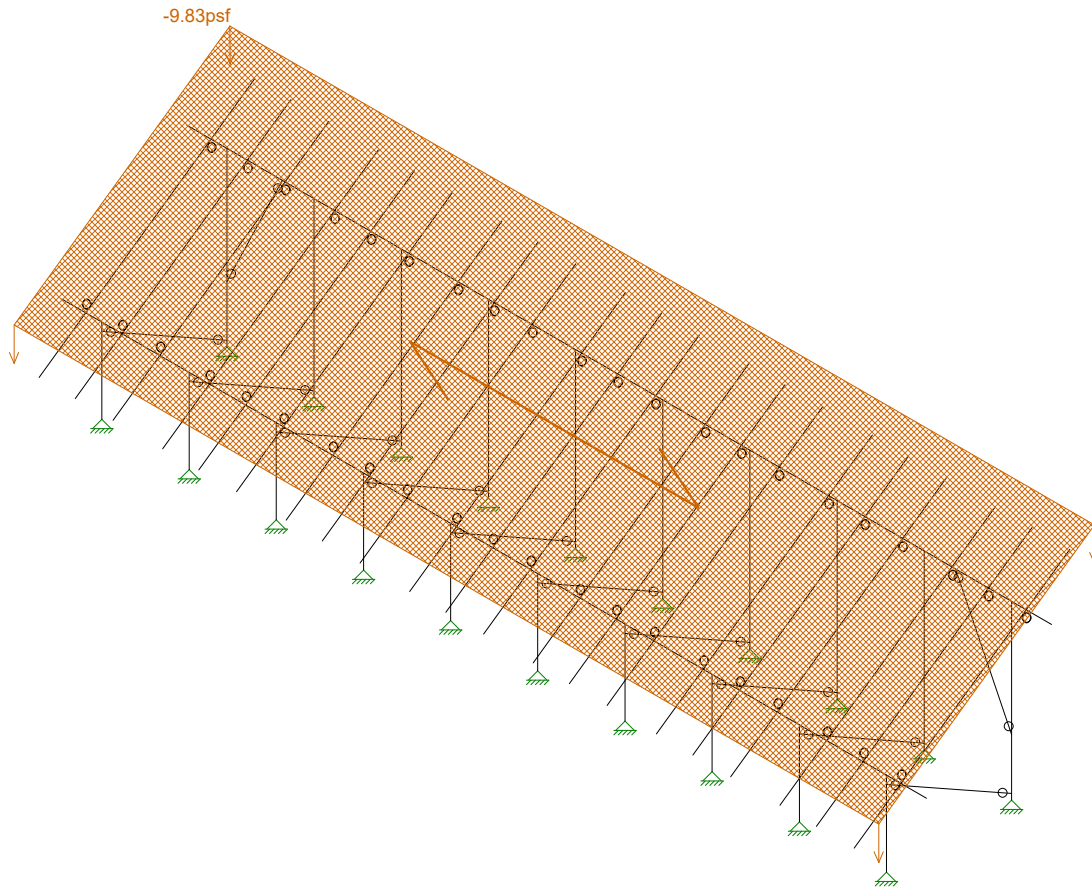

Loads: BLC 3, Roof Live/Snow

Vector Structural Engineeri...	Ground Mount	SK - 6
STB		Apr 12, 2021 at 3:37 PM
U2716.092.191		Sunmodo Sunturf A2 v5 85x45.r3d

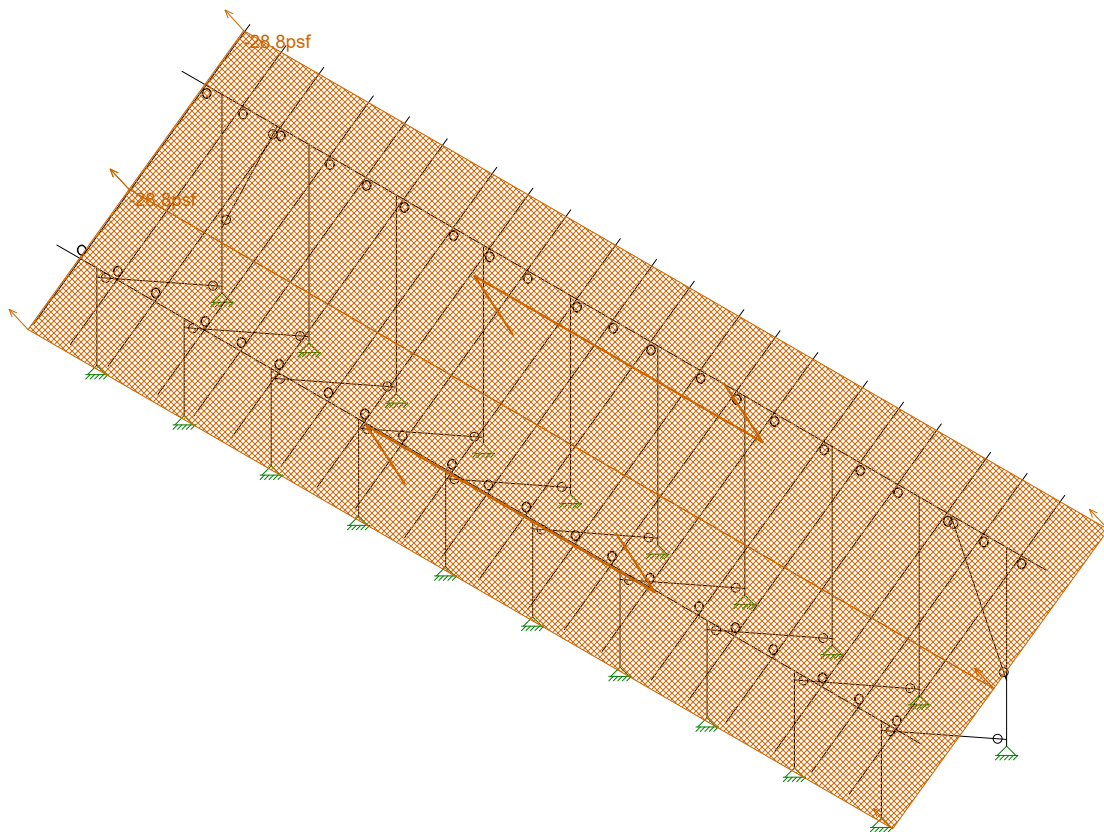

Loads: BLC 4, Wind A 0 deg

Vector Structural Engineeri..	Ground Mount	SK - 7
STB		Apr 12, 2021 at 3:38 PM
U2716.092.191		Sunmodo Sunturf A2 v5 85x45.r3d

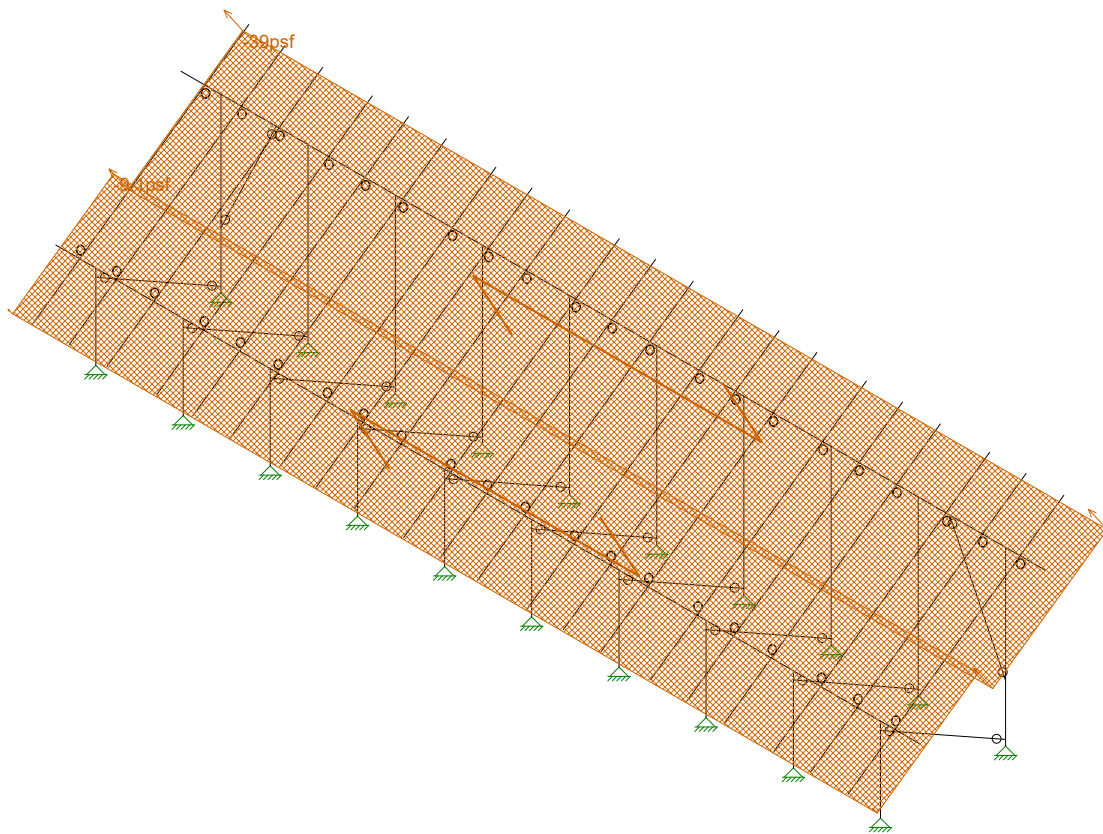

Loads: BLC 5, Wind B 0 deg

Vector Structural Engineeri...	Ground Mount	SK - 8
STB		Apr 12, 2021 at 3:38 PM
U2716.092.191		Sunmodo Sunturf A2 v5 85x45.r3d

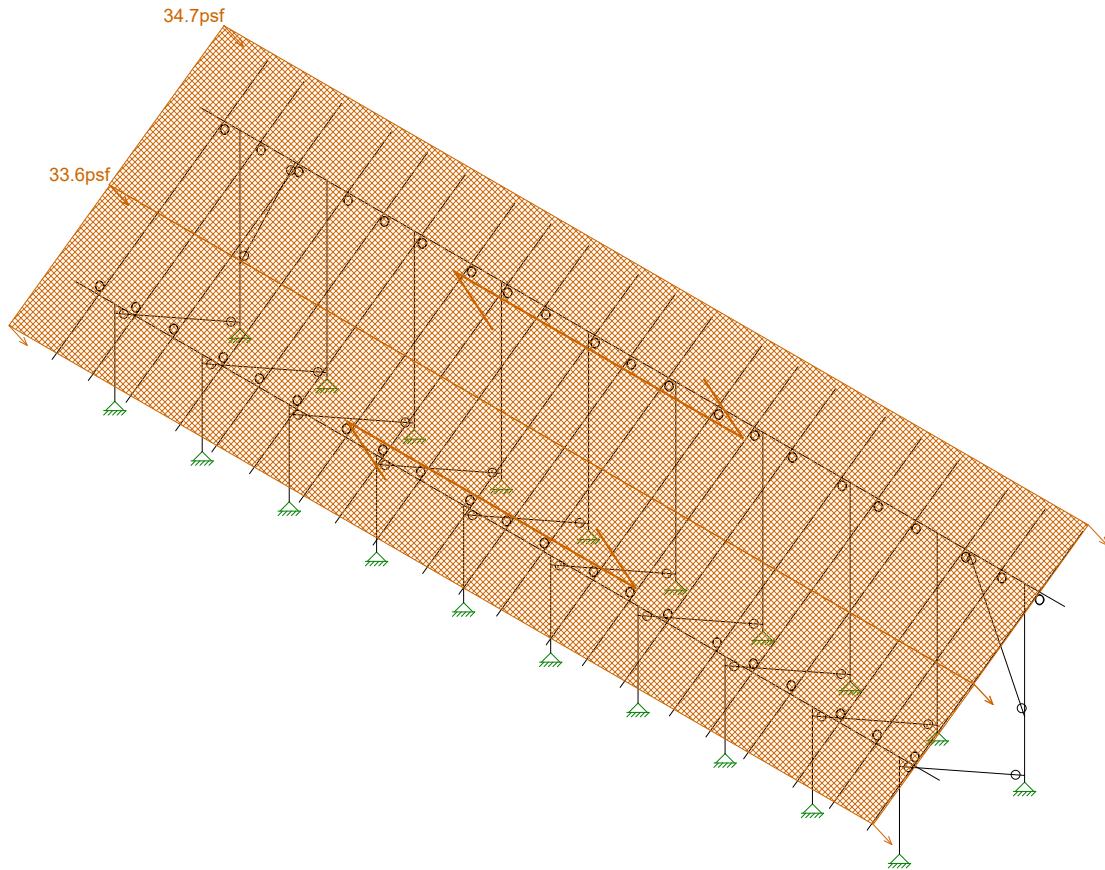

Loads: BLC 6, Wind A 180 deg

Vector Structural Engineeri...
STB
U2716.092.191

Ground Mount

SK - 9

Apr 12, 2021 at 3:38 PM

Sunmodo Sunturf A2 v5 85x45.r3d

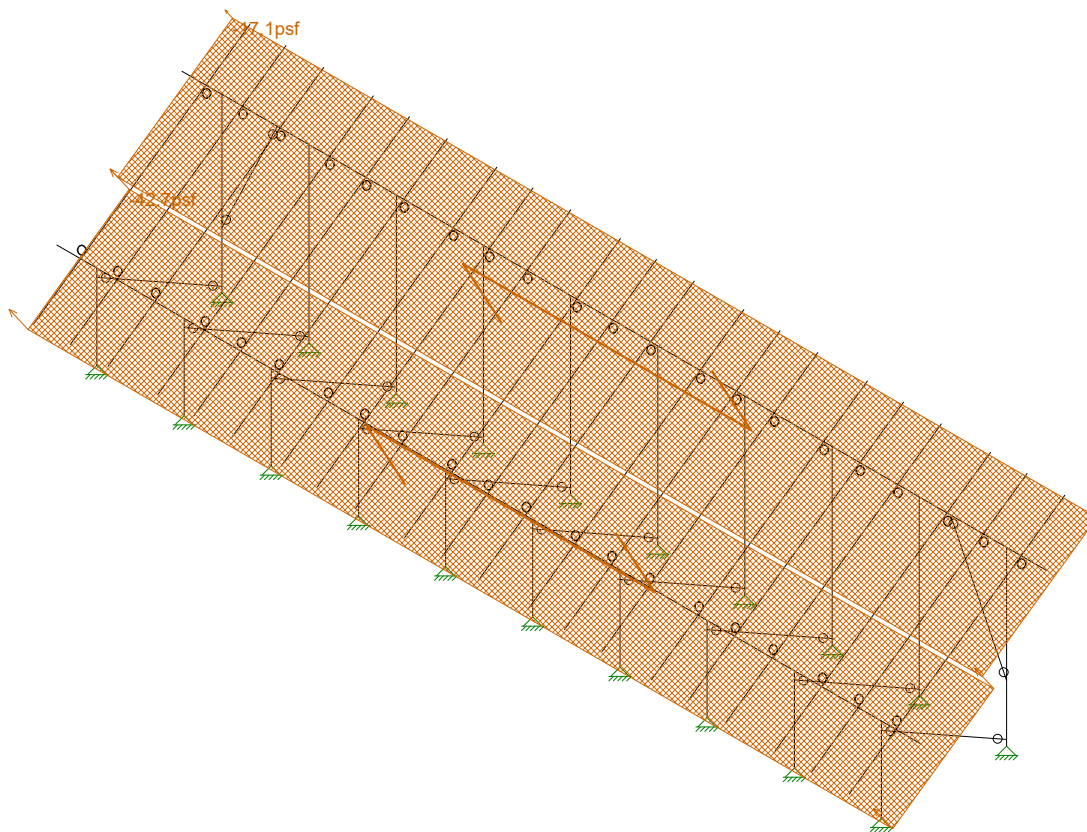

Loads: BLC 7, Wind B 180 deg

Vector Structural Engineeri..	Ground Mount	SK - 10
STB		Apr 12, 2021 at 3:38 PM
U2716.092.191		Sunmodo Sunturf A2 v5 85x45.r3d

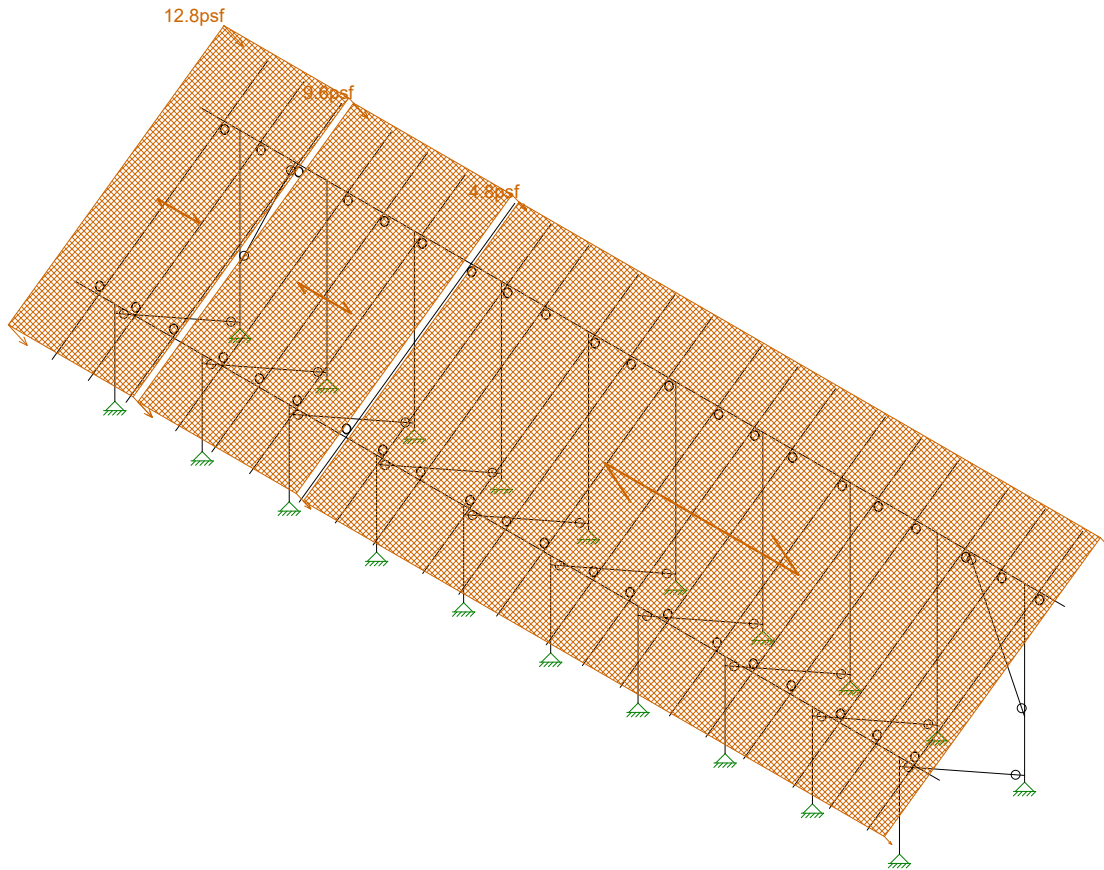

Loads: BLC 8, Wind A 90

Vector Structural Engineeri...
STB
U2716.092.191

Ground Mount

SK - 11

Apr 12, 2021 at 3:38 PM

Sunmodo Sunturf A2 v5 85x45.r3d

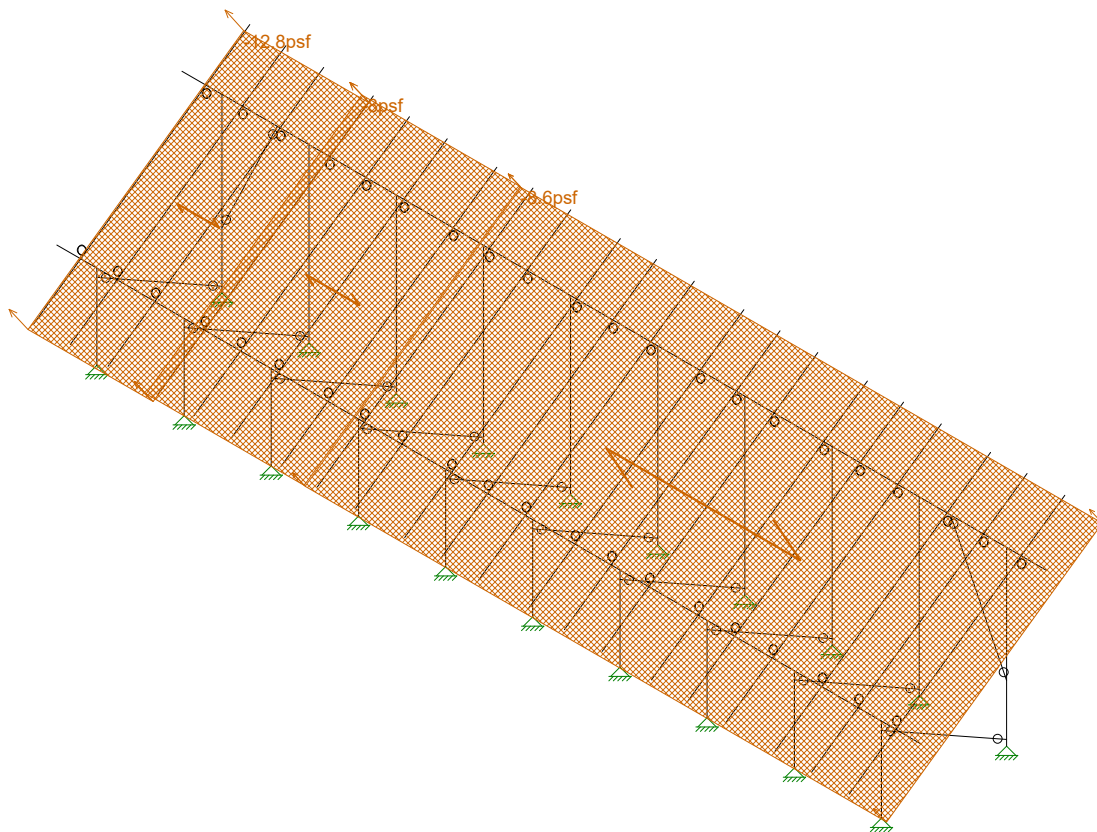

Loads: BLC 9, Wind B 90

Vector Structural Engineeri...
STB
U2716.092.191

Ground Mount

SK - 12

Apr 12, 2021 at 3:38 PM

Sunmodo Sunturf A2 v5 85x45.r3d



Code Check (Env)	
Black	No Calc
Red	> 1.0
Magenta	.90-1.0
Green	.75-.90
Cyan	.50-.75
Blue	0-.50

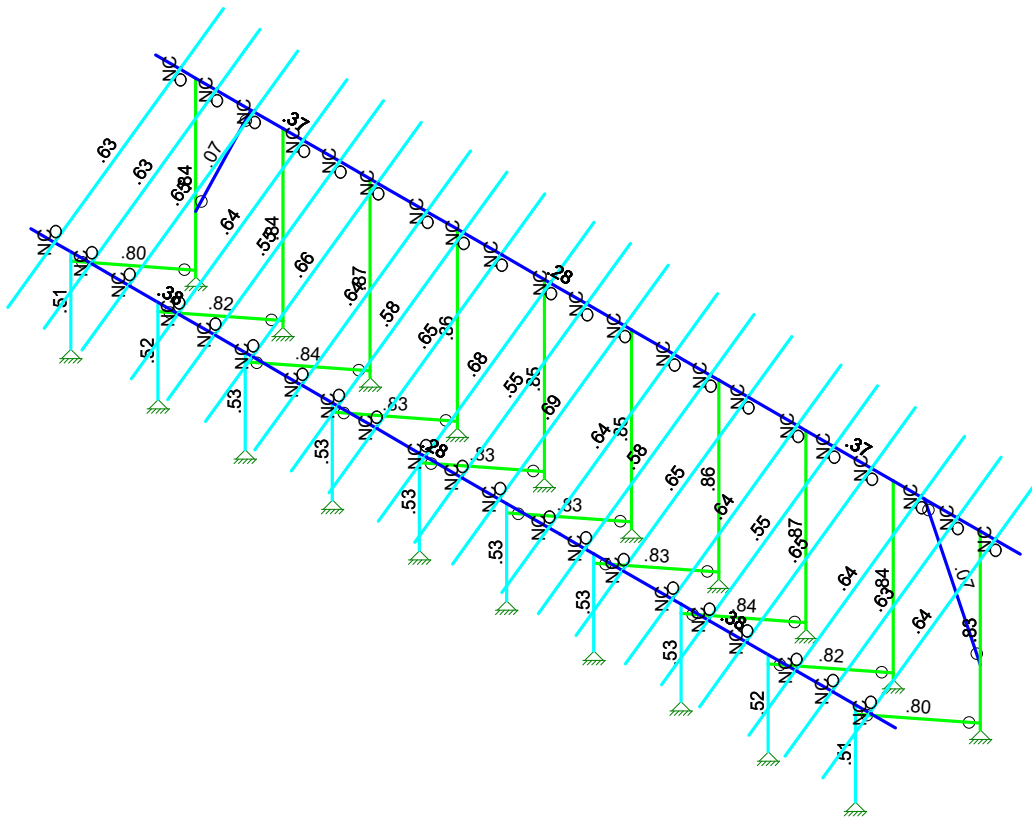

Member Code Checks Displayed (Enveloped)
Envelope Only Solution

Vector Structural Engineeri...	Ground Mount	SK - 1
STB		Apr 12, 2021 at 3:35 PM
U2716.092.191		Sunmodo Sunturf A2 v5 85x45.r3d



(Global) Model Settings

Display Sections for Member Calcs	5
Max Internal Sections for Member Calcs	97
Include Shear Deformation?	Yes
Increase Nailing Capacity for Wind?	Yes
Include Warping?	Yes
Trans Load Btwn Intersecting Wood Wall?	Yes
Area Load Mesh (in^2)	144
Merge Tolerance (in)	.12
P-Delta Analysis Tolerance	0.50%
Include P-Delta for Walls?	Yes
Automatically Iterate Stiffness for Walls?	Yes
Max Iterations for Wall Stiffness	3
Gravity Acceleration (in/sec^2)	386.4
Wall Mesh Size (in)	24
Eigensolution Convergence Tol. (1.E-)	4
Vertical Axis	Y
Global Member Orientation Plane	XZ
Static Solver	Sparse Accelerated
Dynamic Solver	Accelerated Solver

Hot Rolled Steel Code	AISC 13th(360-05): ASD
Adjust Stiffness?	Yes(Iterative)
RISACONNECTION CODE	AISC 13th(360-05): ASD
Cold Formed Steel Code	AISI S100-07: ASD
Wood Code	AWC NDS-15: ASD
Wood Temperature	< 100F
Concrete Code	ACI 318-08
Masonry Code	ACI 530-08: ASD
Aluminum Code	AA ADM1-05: ASD - Building
Stainless Steel Code	AISC 14th(360-10): ASD
Adjust Stiffness?	Yes(Iterative)

Number of Shear Regions	4
Region Spacing Increment (in)	4
Biaxial Column Method	Exact Integration
Parame Beta Factor (PCA)	.65
Concrete Stress Block	Rectangular
Use Cracked Sections?	Yes
Use Cracked Sections Slab?	No
Bad Framing Warnings?	No
Unused Force Warnings?	Yes
Min 1 Bar Diam. Spacing?	No
Concrete Rebar Set	REBAR SET ASTMA615
Min % Steel for Column	1
Max % Steel for Column	8



(Global) Model Settings, Continued

Seismic Code	ASCE 7-10
Seismic Base Elevation (in)	15600
Add Base Weight?	Yes
Ct X	.02
Ct Z	.02
T X (sec)	Not Entered
T Z (sec)	Not Entered
R X	3
R Z	3
Ct Exp. X	.75
Ct Exp. Z	.75
SD1	1
SDS	1
S1	1
TL (sec)	5
Risk Cat	I or II
Drift Cat	Other
Om Z	1
Om X	1
Cd Z	4
Cd X	4
Rho Z	1
Rho X	1

Hot Rolled Steel Properties

	Label	E [ksi]	G [ksi]	Nu	Therm (/1E5 F)	Density[lb/ft^3]	Yield[psi]	Ry	Fu[psi]	Rt
1	A992	29000	11154	.3	.65	490	50000	1.1	65000	1.1
2	A36 Gr.36	29000	11154	.3	.65	490	36000	1.5	58000	1.2
3	A572 Gr.50	29000	11154	.3	.65	490	50000	1.1	65000	1.1
4	A500 Gr.B R...	29000	11154	.3	.65	527	42000	1.4	58000	1.3
5	A500 Gr.B Re...	29000	11154	.3	.65	527	46000	1.4	58000	1.3
6	A53 Gr.B	29000	11154	.3	.65	490	35000	1.6	60000	1.2
7	A1085	29000	11154	.3	.65	490	50000	1.4	65000	1.3

Aluminum Properties

	Label	E [ksi]	G [ksi]	Nu	Therm (...Density[... Table 3.3	kt	Ftu[psi]	Fty[psi]	Fcy[psi]	Fsu[psi]	Ct
1	3003-H14	10100	3787.5	.33	1.3 172.8 Table 3.3-3	1	19000	16000	13000	12000	141
2	6061-T6	10100	3787.5	.33	1.3 172.8 Table 3.3-4	1	38000	35000	35000	24000	141
3	6063-T5	10100	3787.5	.33	1.3 172.8 Table 3.3-4	1	22000	16000	16000	13000	141
4	6063-T6	10100	3787.5	.33	1.3 172.8 Table 3.3-4	1	30000	25000	25000	19000	141
5	5052-H34	10200	3787.5	.33	1.3 172.8 Table 3.3-3	1	34000	26000	24000	20000	141
6	6061-T6 W	10100	3787.5	.33	1.3 172.8 Table 3.3-3	1	24000	15000	15000	15000	141
7	6005-T5	10100	3787.5	.33	1.3 172.8 Table 3.3-3	1	38000	35000	35000	24000	141

Hot Rolled Steel Section Sets

	Label	Shape	Type	Design List	Material	Design R...	A [in2]	Iyy [in4]	Izz [in4]	J [in4]
1	Post	Pipe 2.0 A21165	Column	Pipe	A572 Gr.50	Typical	.776	.499	.499	.998
2	Cross Beam	Pipe 2.0 A21168	Beam	Wide Flange	A572 Gr.50	Typical	.947	.907	.907	1.814
3	Diagonal Brace	1.5x1.5x0.083 ...	HBrace	SquareTube	A36 Gr.36	Typical	.47	.158	.158	.236



Company : Vector Structural Engineering
 Designer : STB
 Job Number : U2716.092.191
 Model Name : Ground Mount

Apr 12, 2021
 3:38 PM
 Checked By: _____

Aluminum Section Sets

	Label	Shape	Type	Design List	Material	Design R...	A [in2]	Iyy [in4]	Izz [in4]	J [in4]
1	AL Posts	2.375ODX0.188	Column	Pipe	6005-T5	Typical	1.29	.778	.778	1.54
2	AL Brace	RT1.5x2x0.15625	VBrace	Rectangular Tubes	6005-T5	Typical	.996	.327	.524	.602
3	AL Rails	HR300	Beam	Rectangular Tubes	6005-T5	Typical	.74	.253	.727	.578
4	AL Cross Beam	Cross Rail	Beam	Rectangular Tubes	6005-T5	Typical	1.909	1.97	4.366	4.017

Member Area Loads (BLC 2 : Solar Panel Weight)

	Joint A	Joint B	Joint C	Joint D	Direction	Distribution	Magnitude[psf]
1	N197	N200	N199	N196	Y	A-B	-3

Member Area Loads (BLC 3 : Roof Live/Snow)

	Joint A	Joint B	Joint C	Joint D	Direction	Distribution	Magnitude[psf]
1	N197	N200	N199	N196	PY	A-B	-12

Member Area Loads (BLC 4 : Wind A 0 deg)

	Joint A	Joint B	Joint C	Joint D	Direction	Distribution	Magnitude[psf]
1	N197	N200	N201	N198	Perp	A-B	-28.8
2	N198	N201	N199	N196	Perp	A-B	-28.8

Member Area Loads (BLC 5 : Wind B 0 deg)

	Joint A	Joint B	Joint C	Joint D	Direction	Distribution	Magnitude[psf]
1	N197	N200	N201	N198	Perp	A-B	-39
2	N198	N201	N199	N196	Perp	A-B	-9.1

Member Area Loads (BLC 6 : Wind A 180 deg)

	Joint A	Joint B	Joint C	Joint D	Direction	Distribution	Magnitude[psf]
1	N197	N200	N201	N198	Perp	A-B	34.7
2	N198	N201	N199	N196	Perp	A-B	33.6

Member Area Loads (BLC 7 : Wind B 180 deg)

	Joint A	Joint B	Joint C	Joint D	Direction	Distribution	Magnitude[psf]
1	N197	N200	N201	N198	Perp	A-B	-17.1
2	N198	N201	N199	N196	Perp	A-B	-42.7

Member Area Loads (BLC 8 : Wind A 90)

	Joint A	Joint B	Joint C	Joint D	Direction	Distribution	Magnitude[psf]
1	N197	N203	N202	N196	Perp	A-B	12.8
2	N203	N209	N208	N202	Perp	A-B	9.6
3	N209	N200	N199	N208	Perp	A-B	4.8

Member Area Loads (BLC 9 : Wind B 90)

	Joint A	Joint B	Joint C	Joint D	Direction	Distribution	Magnitude[psf]
1	N197	N203	N202	N196	Perp	A-B	-12.8
2	N203	N209	N208	N202	Perp	A-B	-8
3	N209	N200	N199	N208	Perp	A-B	-8.6

Basic Load Cases

	BLC Description	Category	X Gravity	Y Gravity	Z Gravity	Joint	Point	Distributed	Area(M...Surface...
1	Self Weight	DL		-1.05					
2	Solar Panel Weight	DL							1



Company : Vector Structural Engineering
 Designer : STB
 Job Number : U2716.092.191
 Model Name : Ground Mount

Apr 12, 2021
 3:38 PM
 Checked By: _____

Envelope Joint Reactions (Continued)

Joint	X [lb]	LC	Y [lb]	LC	Z [lb]	LC	MX [lb-ft]	LC MY [lb-ft]	LC	MZ [lb-ft]	LC			
14	min	-683	11	-2379.976	16	-1409...	6	0	1	0	1	0	20	
15	N122	max	3.476	18	1155.02	10	138.03	3	0	20	0	20	0	20
16		min	-4.149	5	-372.095	17	-164.9...	5	0	1	0	1	0	20
17	N133B	max	1.149	5	2748.43	5	1647.8...	5	0	20	0	20	0	20
18		min	-1.168	16	-2342.032	16	-1398...	6	0	1	0	1	0	20
19	N134B	max	2.195	4	1134.337	10	137.649	3	0	20	0	20	0	20
20		min	-2.628	19	-340.937	17	-164.8...	5	0	1	0	1	0	20
21	N151	max	2.015	16	2730.679	5	1642.02	5	0	20	0	20	0	20
22		min	-2.178	5	-2325.589	16	-1393...	6	0	1	0	1	0	20
23	N152	max	3.466	18	1125.326	10	137.348	3	0	20	0	20	0	20
24		min	-3.064	10	-351.041	17	-164.3...	5	0	1	0	1	0	20
25	N157A	max	1.294	16	2742.075	5	1643.6...	5	0	20	0	20	0	20
26		min	-1.416	5	-2335.369	16	-1395...	6	0	1	0	1	0	20
27	N158A	max	1.218	18	1129.779	10	137.499	3	0	20	0	20	0	20
28		min	-2.518	10	-336.36	17	-164.7...	5	0	1	0	1	0	20
29	N157	max	.712	11	2779.506	5	1664.5...	5	0	20	0	20	0	20
30		min	-.758	16	-2385.47	16	-1411...	6	0	1	0	1	0	20
31	N158	max	4.272	5	1158.812	10	138.158	3	0	20	0	20	0	20
32		min	-3.533	18	-374.875	17	-165.1...	5	0	1	0	1	0	20
33	N157B	max	41.807	16	2685.248	5	1572.11	5	0	20	0	20	0	20
34		min	-32.845	5	-2314.782	16	-1337...	6	0	1	0	1	0	20
35	N158B	max	4.252	18	1086.98	10	133.323	3	0	20	0	20	0	20
36		min	-4.416	11	-326.202	17	-158.8...	5	0	1	0	1	0	20
37	N161C	max	1.234	16	2653.36	5	1635.6...	5	0	20	0	20	0	20
38		min	-1.001	5	-2212.504	16	-1385...	6	0	1	0	1	0	20
39	N162C	max	.225	17	1110.006	10	135.451	3	0	20	0	20	0	20
40		min	-.703	10	-331.916	17	-163.2...	5	0	1	0	1	0	20
41	Totals:	max	.008	7	24690.011	11	14682...	5						
42		min	-.005	8	-15777.447	18	-1249...	18						

Envelope AISC 13th(360-05): ASD Steel Code Checks

Member	Shape	Code Check	Loc[in]	LC	Shear	...	Loc[in]	Dir	LC Pnc/om	[...]	Pnt/om [lb]	Mnyy/om	Mnzz/om	Cb	Eqn
1	M5	Pipe 2.0 A2...	.510	52.503	5	.218	52.503		5	15864.376	23232.186	1397.505	1397.505	2...	H1-1b
2	M6	Pipe 2.0 A2...	.836	3.702	5	.244	0		5	5347.554	23232.186	1397.505	1397.505	1...	H1-1a
3	M13	Pipe 2.0 A2...	.378	88.167	5	.135	147....		5	11641.036	28358.413	2081.747	2081.747	1...	H1-1b
4	M14	Pipe 2.0 A2...	.375	88.167	5	.145	147....		5	11641.036	28358.413	2081.747	2081.747	1...	H1-1b
5	M15	1.5x1.5x0.0...	.796	50.366	5	.026	0	y	5	2438.588	10141.308	449.583	449.583	1...	H1-1a
6	M80	Pipe 2.0 A2...	.526	52.503	5	.224	52.503		5	15864.376	23232.186	1397.505	1397.505	1...	H1-1b
7	M81	Pipe 2.0 A2...	.854	3.702	5	.251	0		5	5347.554	23232.186	1397.505	1397.505	1...	H1-1a
8	M82	1.5x1.5x0.0...	.826	50.366	5	.004	0	y	14	2438.588	10141.308	449.583	449.583	1...	H1-1a
9	M50	Pipe 2.0 A2...	.523	52.503	5	.223	52.503		5	15864.376	23232.186	1397.505	1397.505	1...	H1-1b
10	M51	Pipe 2.0 A2...	.838	3.702	5	.251	0		5	5347.554	23232.186	1397.505	1397.505	1...	H1-1a
11	M52	1.5x1.5x0.0...	.823	50.366	5	.005	98.676	y	8	2438.588	10141.308	449.583	449.583	1...	H1-1a
12	M56A	Pipe 2.0 A2...	.528	52.503	5	.227	52.503		5	15864.376	23232.186	1397.505	1397.505	1...	H1-1b
13	M57A	Pipe 2.0 A2...	.867	3.702	5	.255	0		5	5347.554	23232.186	1397.505	1397.505	2...	H1-1a
14	M58A	1.5x1.5x0.0...	.837	50.366	5	.007	98.676	y	5	2438.588	10141.308	449.583	449.583	1...	H1-1a
15	M68	Pipe 2.0 A2...	.528	52.503	5	.225	52.503		5	15864.376	23232.186	1397.505	1397.505	1...	H1-1b
16	M69	Pipe 2.0 A2...	.860	3.702	5	.253	0		5	5347.554	23232.186	1397.505	1397.505	1...	H1-1a
17	M70	1.5x1.5x0.0...	.830	50.366	5	.005	98.676	y	7	2438.588	10141.308	449.583	449.583	1...	H1-1a
18	M68A	Pipe 2.0 A2...	.277	144....	5	.150	142.5		5	11641.036	28358.413	2081.747	2081.747	1...	H1-1b
19	M69A	Pipe 2.0 A2...	.376	144....	5	.135	21.656		5	11641.036	28358.413	2081.747	2081.747	1...	H1-1b
20	M70A	Pipe 2.0 A2...	.277	144....	5	.162	142.5		5	11641.036	28358.413	2081.747	2081.747	2...	H1-1b
21	M71	Pipe 2.0 A2...	.371	144....	5	.145	21.656		5	11641.036	28358.413	2081.747	2081.747	2...	H1-1b
22	M73	Pipe 2.0 A2...	.527	52.503	5	.224	52.503		5	15864.376	23232.186	1397.505	1397.505	1...	H1-1b
23	M74	Pipe 2.0 A2...	.855	3.702	5	.252	0		5	5347.554	23232.186	1397.505	1397.505	1...	H1-1a



Company : Vector Structural Engineering
 Designer : STB
 Job Number : U2716.092.191
 Model Name : Ground Mount

Apr 12, 2021
 3:38 PM
 Checked By: _____

Envelope AISC 13th(360-05): ASD Steel Code Checks (Continued)

Member	Shape	Code Check	Loc[in]	LC Shear	Dir	LC Pnc/om	Pnt/om [lb]	Mnvy/om	Mnzz/om	Cb	Eqn				
24	M75	1.5x1.5x0.0...	.828	50.366	5	.004	98.676	y	10	2438.588	10141.308	449.583	449.583	1...	H1-1a
25	M76	Pipe 2.0 A2...	.528	52.503	5	.224	52.503		5	15864.376	23232.186	1397.505	1397.505	2...	H1-1b
26	M77	Pipe 2.0 A2...	.857	3.702	5	.252	0		5	5347.554	23232.186	1397.505	1397.505	1...	H1-1a
27	M78	1.5x1.5x0.0...	.828	50.366	5	.004	98.676	y	10	2438.588	10141.308	449.583	449.583	1...	H1-1a
28	M76A	Pipe 2.0 A2...	.529	52.503	5	.228	52.503		5	15864.376	23232.186	1397.505	1397.505	1...	H1-1b
29	M77A	Pipe 2.0 A2...	.869	3.702	5	.256	0		5	5347.554	23232.186	1397.505	1397.505	1...	H1-1a
30	M78A	1.5x1.5x0.0...	.839	50.366	5	.007	98.676	y	5	2438.588	10141.308	449.583	449.583	1...	H1-1a
31	M76B	Pipe 2.0 A2...	.509	52.503	5	.218	52.503		5	15864.376	23232.186	1397.505	1397.505	2...	H1-1b
32	M77B	Pipe 2.0 A2...	.835	3.702	5	.243	0		5	5347.554	23232.186	1397.505	1397.505	1...	H1-1a
33	M78B	1.5x1.5x0.0...	.795	50.366	5	.026	0	y	5	2438.588	10141.308	449.583	449.583	1...	H1-1a
34	M78C	Pipe 2.0 A2...	.523	52.503	5	.223	52.503		5	15864.376	23232.186	1397.505	1397.505	1...	H1-1b
35	M79	Pipe 2.0 A2...	.839	3.702	5	.251	0		5	5347.554	23232.186	1397.505	1397.505	1...	H1-1a
36	M80A	1.5x1.5x0.0...	.824	50.366	5	.003	98.676	y	13	2438.588	10141.308	449.583	449.583	1...	H1-1a

Envelope AA ADM1-05: ASD - Building Aluminum Code Checks

Member	Shape	Code	Loc[in]	LC Shear	Dir	LC Fc [psi]	Ft [psi]	Fb y-y	Fb z-z	Fs y-y	Fs z-z	Cb	Cmy	Cmz	Eqn				
1	M19	RT1.5x2...	.067	55.055	5	.019	0	y	5	2162.8	19487...	21212	20895...	12246...	12246...	1...	.6	.6	4.1.1-3
2	M16	HR300	.632	39.644	18	.061	41.532	y	5	8433.0	19487...	19487...	19487...	12246...	12246...	2...	.6	.6	4.1.2-1
3	M38	HR300	.652	39.644	18	.065	143...	y	5	8433.0	19487...	19487...	19487...	12246...	12246...	1...	.6	.6	4.1.2-1
4	M41	HR300	.641	39.644	18	.066	143...	y	16	8433.0	19487...	19487...	19487...	12246...	12246...	1...	.6	.6	4.1.2-1
5	M44	HR300	.657	92.502	15	.065	143...	y	5	4551.1	19487...	18800	20407...	12246...	12246...	1...	.996	.997	4.1.1-1
6	M47	HR300	.641	39.644	18	.063	41.532	y	5	8433.0	19487...	19487...	19487...	12246...	12246...	1...	.6	.6	4.1.2-1
7	M50A	HR300	.652	39.644	18	.064	41.532	y	5	8433.0	19487...	19487...	19487...	12246...	12246...	1...	.6	.6	4.1.2-1
8	M53	HR300	.684	92.502	15	.064	143...	y	5	4551.1	19487...	18800	20401...	12246...	12246...	1...	.996	.988	4.1.1-1
9	M56	HR300	.693	92.502	15	.065	143...	y	5	4551.1	19487...	18800	20402...	12246...	12246...	1...	.996	.989	4.1.1-1
10	M59	HR300	.641	39.644	18	.063	41.532	y	5	8433.0	19487...	19487...	19487...	12246...	12246...	1...	.6	.6	4.1.2-1
11	M62	HR300	.652	39.644	18	.064	41.532	y	5	8433.0	19487...	19487...	19487...	12246...	12246...	1...	.6	.6	4.1.2-1
12	M65	HR300	.644	92.502	15	.064	143...	y	5	4551.1	19487...	18800	20407...	12246...	12246...	1...	.996	.997	4.1.1-1
13	M68B	HR300	.652	39.644	18	.067	143...	y	16	8433.0	19487...	19487...	19487...	12246...	12246...	1...	.6	.6	4.1.2-1
14	M71A	HR300	.641	39.644	18	.064	143...	y	16	8433.0	19487...	19487...	19487...	12246...	12246...	1...	.6	.6	4.1.2-1
15	M74A	HR300	.643	39.644	18	.062	41.532	y	5	8433.0	19487...	19487...	19487...	12246...	12246...	2...	.6	.6	4.1.2-1
16	M75A	RT1.5x2...	.067	54.204	5	.018	0	y	5	2157.4	19487...	21212	20893...	12246...	12246...	1...	.6	.6	4.1.1-3
17	M83	HR300	.633	39.644	18	.058	41.532	y	5	8433.0	19487...	19487...	19487...	12246...	12246...	2...	.6	.6	4.1.2-1
18	M86	HR300	.554	39.644	18	.056	41.532	y	5	8433.0	19487...	19487...	19487...	12246...	12246...	1...	.6	.6	4.1.2-1
19	M89	HR300	.584	92.502	15	.056	143...	y	5	4551.1	19487...	18800	20400...	12246...	12246...	1...	.996	.986	4.1.1-1
20	M92	HR300	.554	39.644	18	.054	41.532	y	5	8433.0	19487...	19487...	19487...	12246...	12246...	1...	.6	.6	4.1.2-1
21	M95	HR300	.580	92.502	15	.056	143...	y	5	4551.1	19487...	18800	20401...	12246...	12246...	1...	.996	.987	4.1.1-1
22	M98	HR300	.554	39.644	18	.056	41.532	y	5	8433.0	19487...	19487...	19487...	12246...	12246...	1...	.6	.6	4.1.2-1
23	M101	HR300	.634	39.644	18	.058	41.532	y	5	8433.0	19487...	19487...	19487...	12246...	12246...	2...	.6	.6	4.1.2-1

NOTES: UNLESS OTHERWISE SPECIFIED
 1. DIMENSIONS SHOWN ARE INCHES [MILLIMETERS].

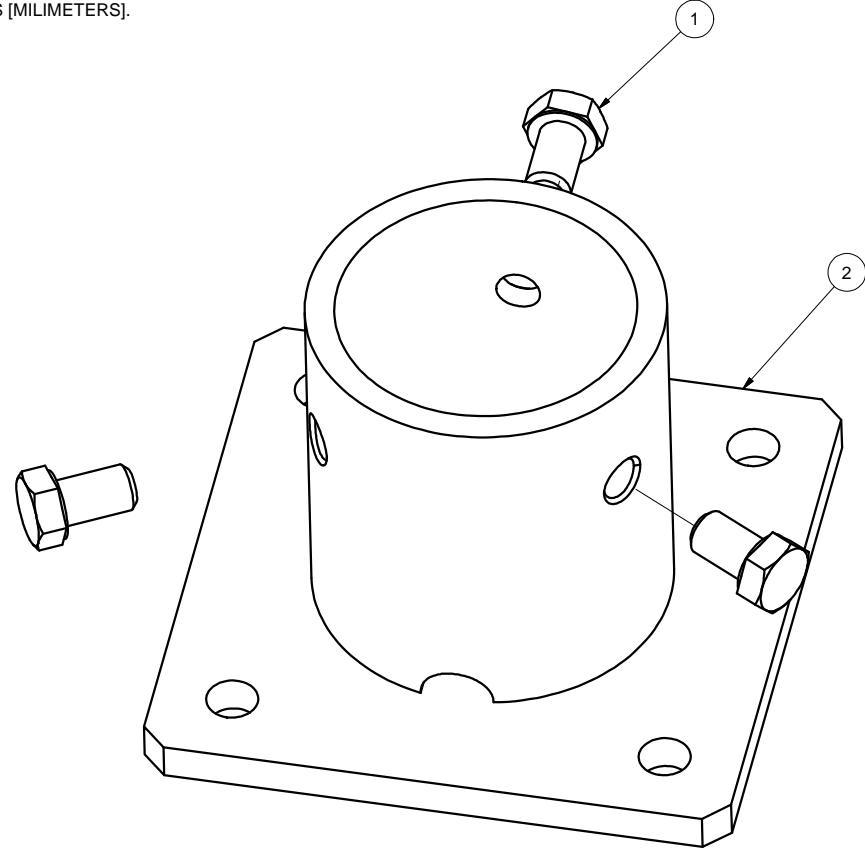

REVISIONS			
REV	DESCRIPTION	BY	DATE
A	INITIAL RELEASE	LWF	10/20/2016

2	A21120-001	2" PIPE BASE	1
1	B15018-011	HEX CAP SCREW 3/8-16 X 5/8	3
ITEM	PART NUMBER	DESCRIPTION	QTY
MATERIAL		SEE NOTES	
Third Angle Projection:			
GENERAL SPECIFICATIONS		Sunmodo Corp. 1905 E 5TH STREET, STE A, VANCOUVER, WA 98661	
Tolerances		TITLE	
X.XXX ±0.01 [0.25mm]		2" PIPE BASE KIT	
X.XX ±0.02 [0.50mm]		DRAWING NUMBER	
X.X ±0.039 [1.0mm]		B K10268-001	
Unless otherwise spec'd		SCALE: NONE	
DRAWN BY		SHEET 1 of 1	
LWF		DATE	
CHECKED BY		10/20/2016	
APPROVALS			

THIS DRAWING IS CONFIDENTIAL PROPERTY OF SUNMODO AND ITS CONTENTS MAY NOT BE DISCLOSED WITHOUT THE PRIOR WRITTEN CONSENT OF SUNMODO CORP.

NOTES: UNLESS OTHERWISE SPECIFIED

1. DIMENSIONS SHOWN ARE INCHES [MILIMETERS].
2. MATERAIL: ALUMINUM 6005-T5.
FINISH: CLEAR ANODIZED 10 μ m THICK.
3. THE UNSPECIFIED DIMENSIONS ARE SPECIFIED BY 2D CAD FILE.

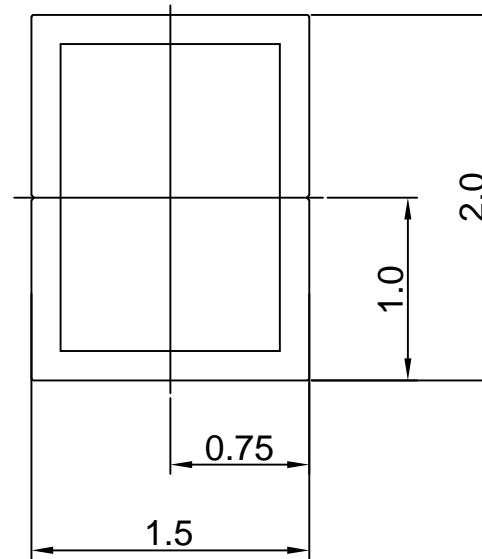

Section properties:

Weight: 1.156 lbs/ft

Area: 0.992 in²

Perimeter: 12.601 in

Bounding Box: X: -1.000,1.000

Y: -0.750, 0.750

Centroid:(0.000,0.000)

Moments of Inertia(in⁴): I_x=0.506,I_y=0.322

Section modulus in bending(in³): W_x=0.675,W_y=0.322

Radii of Gyration: X: 0.714, Y: 0.570

MATERIAL		SEE NOTES	
Third Angle Projection:			
GENERAL SPECIFICATIONS			
All Dimensions in inches [millimeters]			
Tolerances			
X.XXX ± 0.01 [0.25mm]	Break all sharp edges		
X.XX ± 0.02 [0.50mm]	.010-.020 unless		
X.X ± 0.039 [1.0mm]	otherwise specified.		
DRAWN BY		DATE	
zcg		03/12/2014	
CHECKED BY			
APPROVALS			
		TITLE	
		1905 E 5TH STREET, SUITE A, VANCOUVER, WA 98661	
		1.5X2 AL TUBE BRACE EXTRUSION	
		DRAWING NUMBER	
		A20164	
		SCALE: NONE	
		SHEET 1 of 1	

REVISIONS			
REV	DESCRIPTION	BY	DATE
A	ADDED BOTTOM CHANNEL & CHANGED ONE 3/8 CHANNEL TO 1/4	zcg	02/21/2013

NOTES: UNLESS OTHERWISE SPECIFIED

1. DIMENSIONS SHOWN ARE INCHES [MILIMETERS].
2. MATERAIL: ALUMINUM 6005-T5.
FINISH: CLEAR ANODIZED 15 μm THICK.
3. THE UNSPECIFIED DIMENSIONS ARE SPECIFIED BY 2D CAD FILE.

2X 1/4 BOLT SLOT

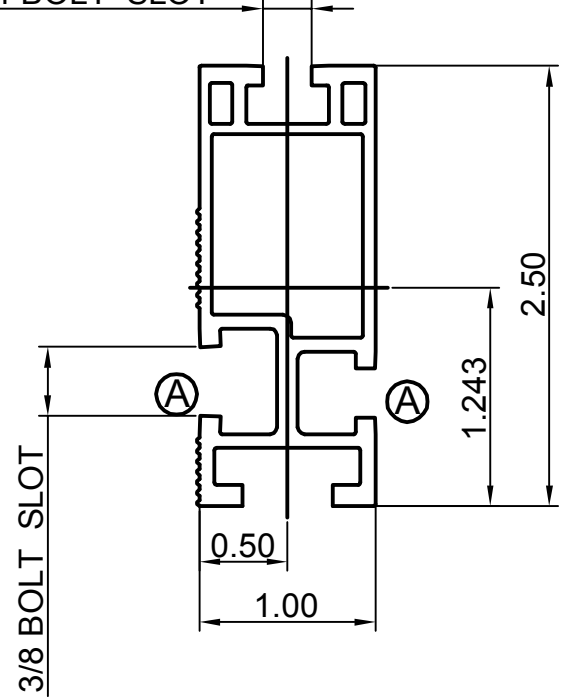

Section properties:

Weight: 0.850 lbs/ft
 Area: 0.723 in²
 Perimeter: 17.325 in
 Bounding Box: X: -0.500,0.500
 Y: -1.243,1.257

Centroid:(0.000,0.000)
 Moments of Inertia(in⁴): Ix=0.486,Iy=0.095
 Section modulus in bending(in³): Wx=0.387,Wy=0.190
 Radii of Gyration: X: 0.820, Y: 0.363

MATERIAL SEE NOTES		Sunmodo Corp.	
Third Angle Projection:			
GENERAL SPECIFICATIONS All Dimensions in inches [millimeters]		1905 E 5TH STREET, SUITE A, VANCOUVER, WA 98661	
Tolerances: X.XXX ± 0.01 [0.25mm] X.XX ± 0.02 [0.50mm] X.X ± 0.039 [1.0mm] Unless otherwise spec'd		TITLE HELIO STANDARD RAIL	
DRAWN BY zcg	DATE 02/21/2013	DRAWING NUMBER A20144	
CHECKED BY		SCALE: NONE SHEET 1 of 1	
APPROVALS			

NOTES: UNLESS OTHERWISE SPECIFIED

1. DIMENSIONS SHOWN ARE INCHES [MILIMETERS].
2. MATERIAL: 6005-T5.
FINISH: CLEAR ANODIZED 10um THICK.
3. THE UNSPECIFIED RADII ARE .02" MAX.
4. THE UNSPECIFIED DIMENSIONS ARE SPECIFIED BY 2D CAD FILE.

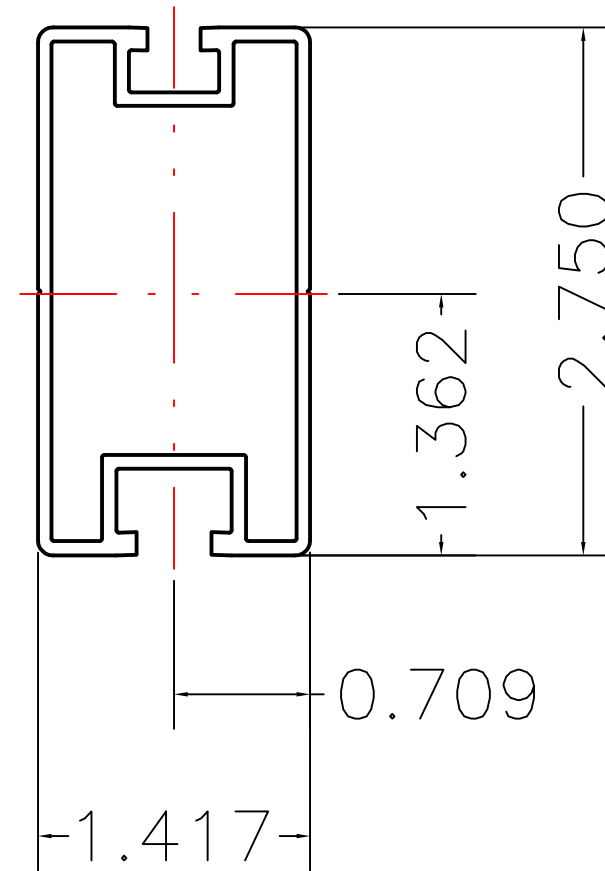

Section properties:

Weight: 0.862 lbs/ft
 Area: 0.736 in²
 Perimeter: 19.824 in
 Bounding Box: X: -0.709,0.709
 Y: -1.362,1.388
 Centroid:(0.000,0.000)
 Moments of Inertia(in⁴): I_x=0.727,I_y=0.214
 Section modulus in bending(in³): W_x=0.524,W_y=0.302
 Radii of Gyration: X: 0.994, Y: 0.539

THIS DRAWING IS CONFIDENTIAL PROPERTY OF SUNMODO AND ITS CONTENTS MAY NOT BE DISCLOSED WITHOUT THE PRIOR WRITTEN CONSENT OF SUNMODO CORP.

MATERIAL SEE NOTES		SunModo Corp. 14800 NE 65TH STREET, VANCOUVER WA 98682	
Third Angle Projection:			
GENERAL SPECIFICATIONS All Dimensions in inches [millimeters]		TITLE RAIL, HR300 (SUNRAY), EXTRUSION	
Tolerances X.XXX ±0.01 [0.25mm] X.XX ±0.02 [0.50mm] Break all sharp edges X.X ±0.039 [1.0mm] .010-.020 unless Unless otherwise spec'd otherwise specified.			
DRAWN BY KYY	DATE 01/18/2018	B	DRAWING NUMBER A20288
CHECKED BY			
APPROVALS		SCALE: NONE	SHEET 1 of 1

REV	DESCRIPTON	BY	DATE
A	0.44 WAS 0.41, 0.44 WAS 0.33	LWF	11/30/2015

NOTES: UNLESS OTHERWISE SPECIFIED

1. DIMENSIONS SHOWN ARE INCHES [MILIMETERS].
2. MATERIAL: ALUMINUM 6005-T5.
FINISH: CLEAR ANODIZED 15 μ m THICK.
3. THE UNSPECIFIED DIMENSIONS ARE SPECIFIED BY 2D CAD FILE.

2X 1/4 BOLT SLOT

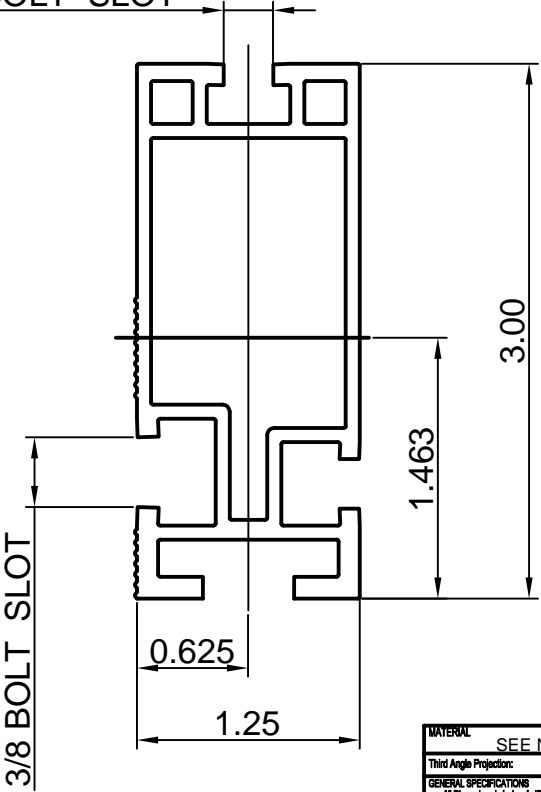

Section properties:

Weight: 1.151 lbs/ft
 Area: 0.980 in²
 Perimeter: 22.104 in
 Bounding Box: X: -0.625,0.625
 Y: -1.463,1.537
 Centroid:(0.000,0.000)
 Moments of Inertia(in⁴): Ix=1.047,Iy=0.207
 Section modulus in bending(in³): Wx=0.681,Wy=0.331
 Radii of Gyration: X: 1.034, Y: 0.460

MATERIAL		SEE NOTES	
Third Angle Projection			
GENERAL SPECIFICATIONS			
All Dimensions in Inches [millimeters]			
Tolerances			
XXX ±0.01 (0.25mm)			
XX ±0.02 (0.50mm)			
X ±0.03 (1.0mm)			
Unless otherwise specified.			
Break all sharp edges 0.10-0.25 unless otherwise specified.			
DRAWN BY		DATE	
ZCJ		02/21/2015	
CHECKED BY		APPROVALS	
TITLE		1905 E 5TH STREET, SUITE A, VANCOUVER, WA 98661	
HELIO HEAVY RAIL		DRAWING NUMBER	
B		A20145	
SCALE:		SHEET	
NONE		1 of 1	

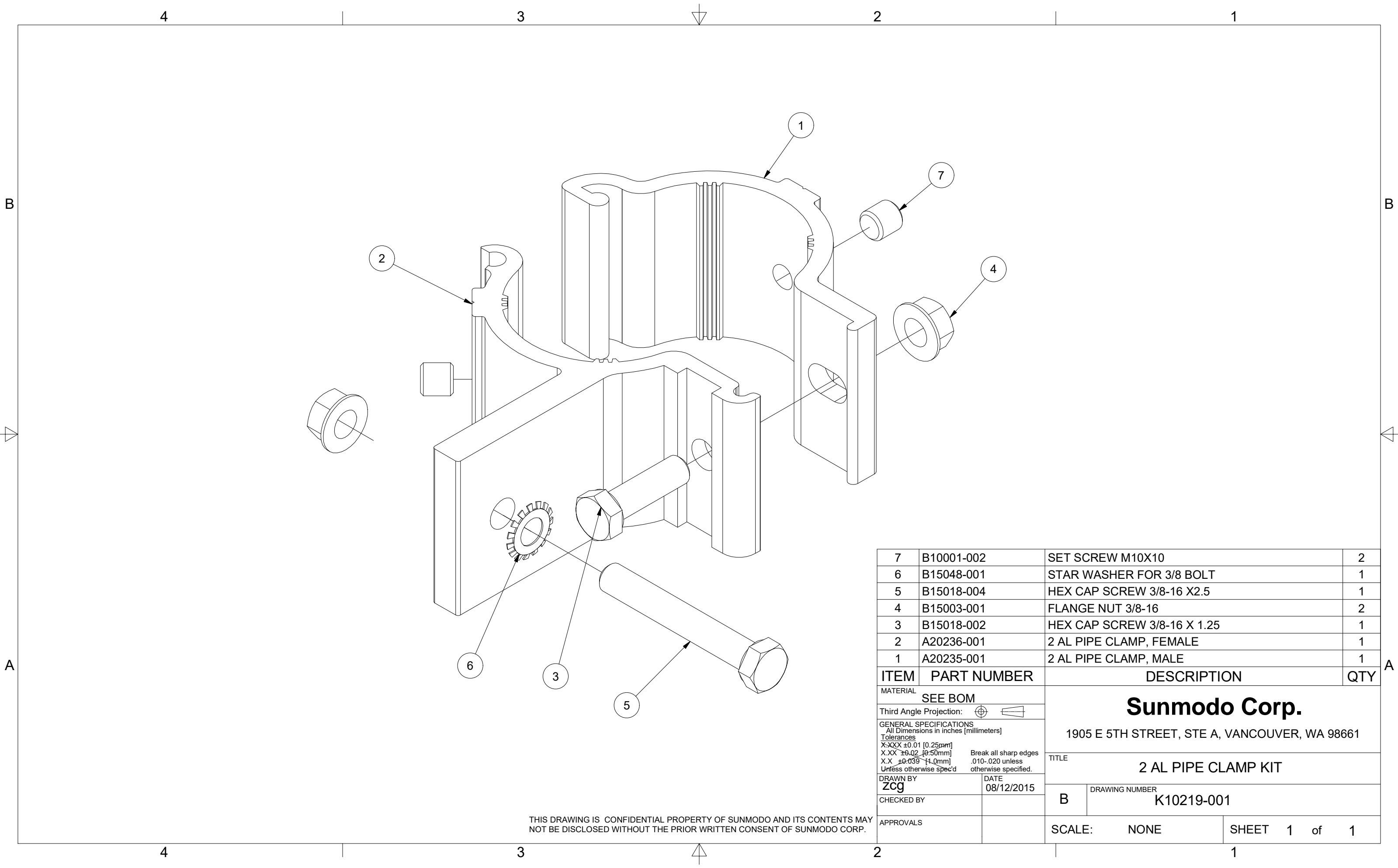

7	B10001-002	SET SCREW M10X10	2
6	B15048-001	STAR WASHER FOR 3/8 BOLT	1
5	B15018-004	HEX CAP SCREW 3/8-16 X2.5	1
4	B15003-001	FLANGE NUT 3/8-16	2
3	B15018-002	HEX CAP SCREW 3/8-16 X 1.25	1
2	A20236-001	2 AL PIPE CLAMP, FEMALE	1
1	A20235-001	2 AL PIPE CLAMP, MALE	1

ITEM	PART NUMBER	DESCRIPTION	QTY
MATERIAL		SEE BOM	
Third Angle Projection:			
GENERAL SPECIFICATIONS All Dimensions in inches (millimeters)			
Tolerances			
X.XXX ±0.01 [0.25mm]		Break all sharp edges	
X.XX ±0.02 [0.50mm]		.010-.020 unless	
X.X ±0.039 [1.0mm]		otherwise specified.	
DRAWN BY		DATE	
zcg		08/12/2015	
CHECKED BY		B	
APPROVALS		DRAWING NUMBER	
		K10219-001	
SCALE:		NONE	SHEET 1 of 1

Sunmodo Corp.
1905 E 5TH STREET, STE A, VANCOUVER, WA 98661

TITLE
2 AL PIPE CLAMP KIT

THIS DRAWING IS CONFIDENTIAL PROPERTY OF SUNMODO AND ITS CONTENTS MAY NOT BE DISCLOSED WITHOUT THE PRIOR WRITTEN CONSENT OF SUNMODO CORP.

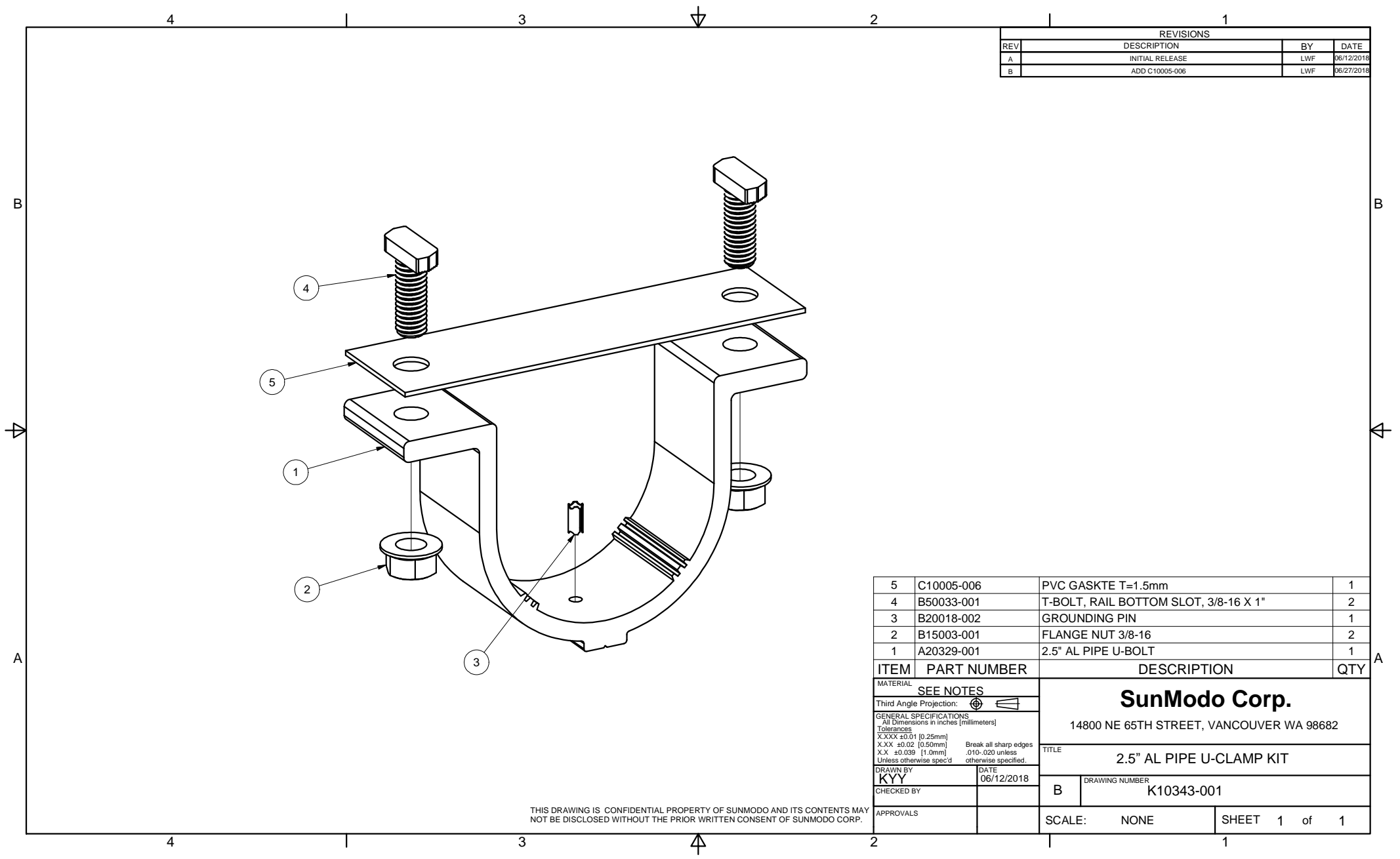

REVISIONS			
REV	DESCRIPTION	BY	DATE
A	INITIAL RELEASE	LWF	06/12/2018
B	ADD C10005-006	LWF	06/27/2018

ITEM	PART NUMBER	DESCRIPTION	QTY
5	C10005-006	PVC GASKTE T=1.5mm	1
4	B50033-001	T-BOLT, RAIL BOTTOM SLOT, 3/8-16 X 1"	2
3	B20018-002	GROUNDING PIN	1
2	B15003-001	FLANGE NUT 3/8-16	2
1	A20329-001	2.5" AL PIPE U-BOLT	1

MATERIAL		SEE NOTES	
Third Angle Projection:			
GENERAL SPECIFICATIONS		SunModo Corp. 14800 NE 65TH STREET, VANCOUVER WA 98682	
Tolerances		TITLE	
X.XXX ±0.01 [0.25mm] X.XX ±0.02 [0.50mm] X.X ±0.039 [1.0mm] Unless otherwise spec'd		2.5" AL PIPE U-CLAMP KIT	
DRAWN BY	DATE	DRAWING NUMBER	
KYY	06/12/2018	B K10343-001	
CHECKED BY		SCALE: NONE SHEET 1 of 1	
APPROVALS			

THIS DRAWING IS CONFIDENTIAL PROPERTY OF SUNMODO AND ITS CONTENTS MAY NOT BE DISCLOSED WITHOUT THE PRIOR WRITTEN CONSENT OF SUNMODO CORP.

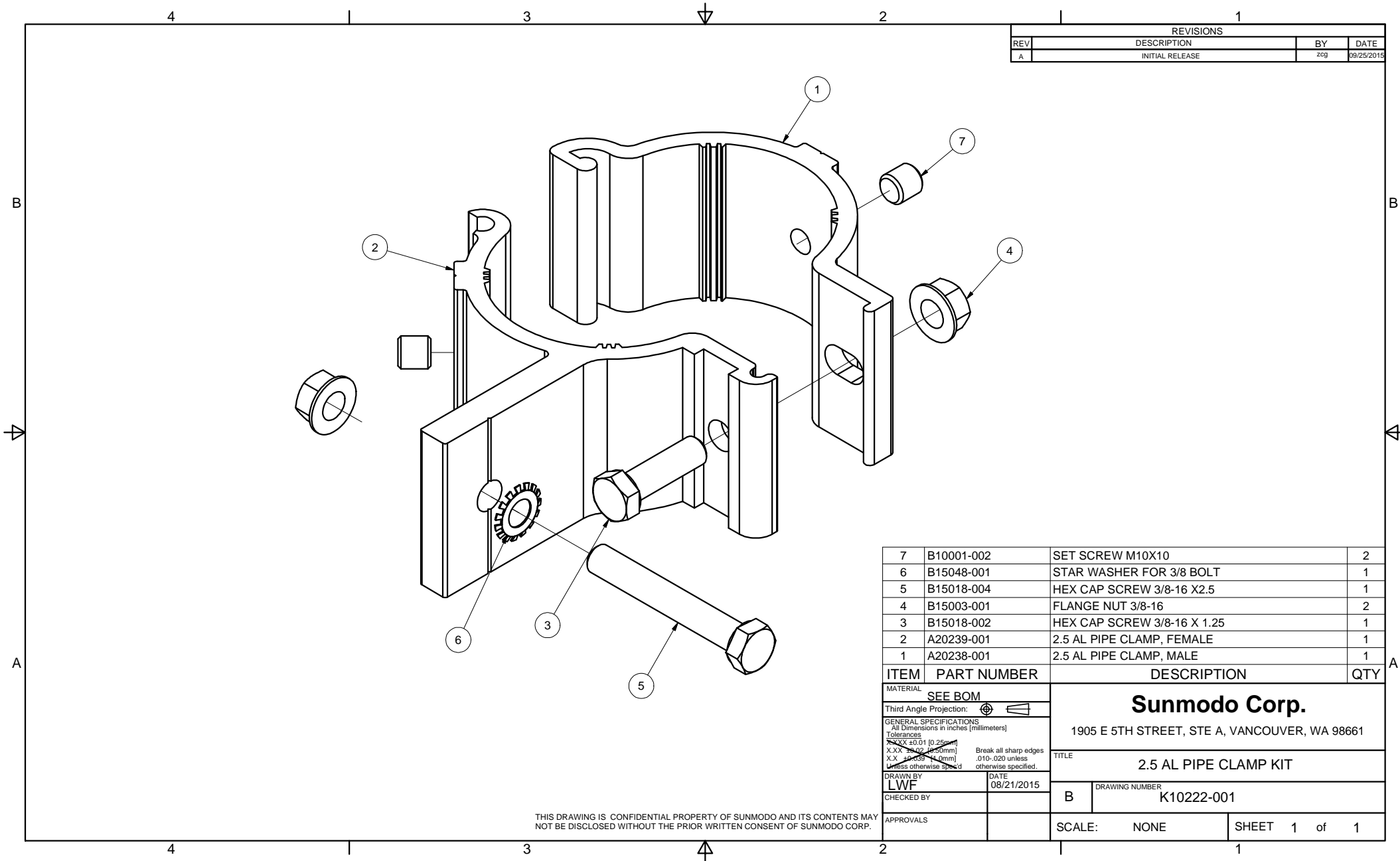

REVISIONS			
REV	DESCRIPTION	BY	DATE
A	INITIAL RELEASE	zcg	09/25/2015

ITEM	PART NUMBER	DESCRIPTION	QTY
7	B10001-002	SET SCREW M10X10	2
6	B15048-001	STAR WASHER FOR 3/8 BOLT	1
5	B15018-004	HEX CAP SCREW 3/8-16 X2.5	1
4	B15003-001	FLANGE NUT 3/8-16	2
3	B15018-002	HEX CAP SCREW 3/8-16 X 1.25	1
2	A20239-001	2.5 AL PIPE CLAMP, FEMALE	1
1	A20238-001	2.5 AL PIPE CLAMP, MALE	1

MATERIAL		SEE BOM	
Third Angle Projection:			
GENERAL SPECIFICATIONS All Dimensions in inches [millimeters] Tolerances X.XX ±0.01 [0.25mm] X.X ±0.02 [0.5mm] X.X ±0.03 [0.75mm] Unless otherwise specified.			
DRAWN BY		DATE	
LWF		08/21/2015	
CHECKED BY		B	
APPROVALS		SCALE: NONE	
		SHEET 1 of 1	

Sunmodo Corp.
 1905 E 5TH STREET, STE A, VANCOUVER, WA 98661

TITLE: **2.5 AL PIPE CLAMP KIT**

DRAWING NUMBER: **K10222-001**

THIS DRAWING IS CONFIDENTIAL PROPERTY OF SUNMODO AND ITS CONTENTS MAY NOT BE DISCLOSED WITHOUT THE PRIOR WRITTEN CONSENT OF SUNMODO CORP.

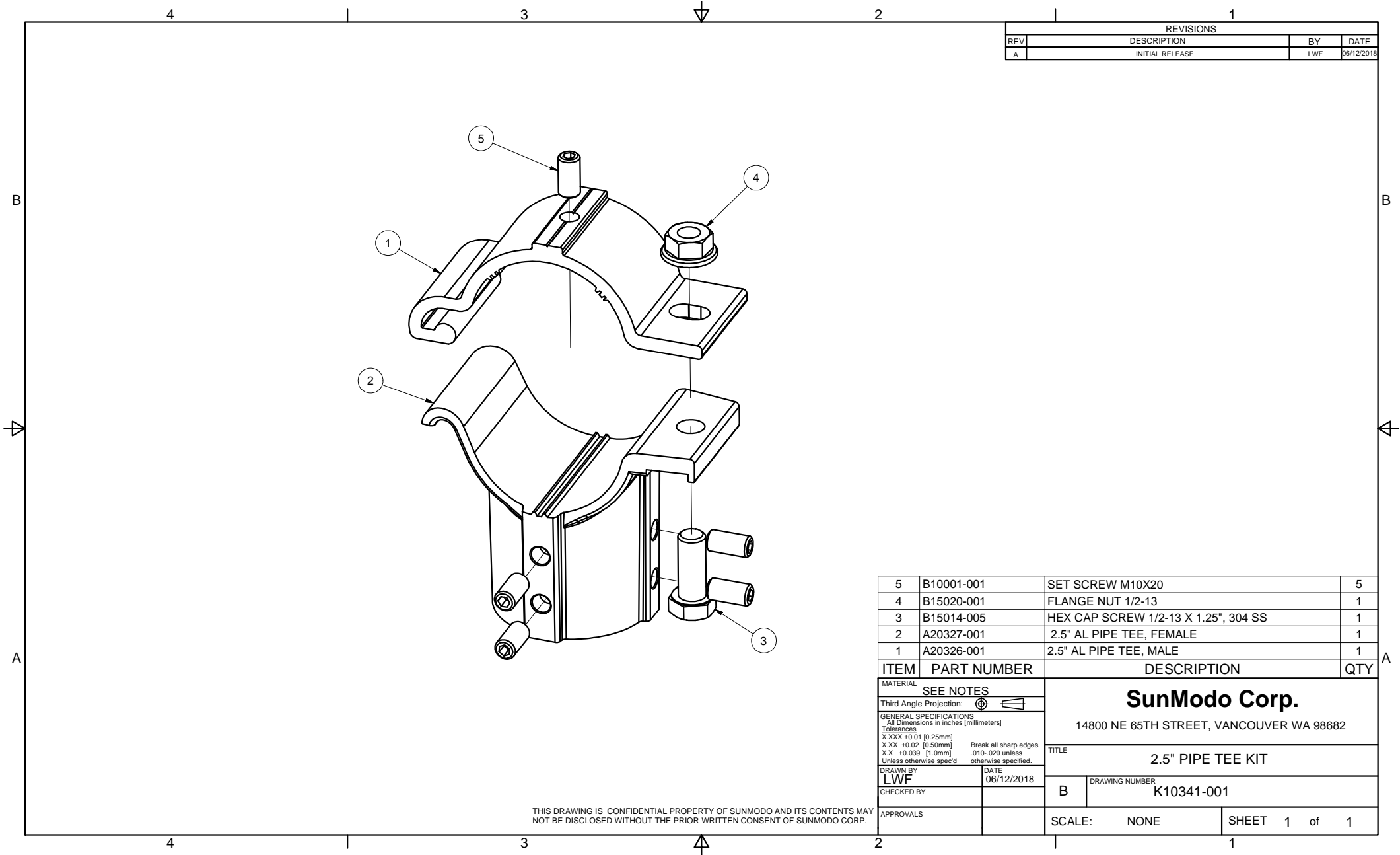

REVISIONS			
REV	DESCRIPTION	BY	DATE
A	INITIAL RELEASE	LWF	06/12/2018

ITEM	PART NUMBER	DESCRIPTION	QTY
5	B10001-001	SET SCREW M10X20	5
4	B15020-001	FLANGE NUT 1/2-13	1
3	B15014-005	HEX CAP SCREW 1/2-13 X 1.25", 304 SS	1
2	A20327-001	2.5" AL PIPE TEE, FEMALE	1
1	A20326-001	2.5" AL PIPE TEE, MALE	1

MATERIAL		SEE NOTES	
Third Angle Projection:			
GENERAL SPECIFICATIONS		SunModo Corp. 14800 NE 65TH STREET, VANCOUVER WA 98682	
Tolerances		TITLE	
X.XXX ±0.01 [0.25mm] X.XX ±0.02 [0.50mm] X.X ±0.039 [1.0mm] Unless otherwise spec'd		2.5" PIPE TEE KIT	
DRAWN BY		DATE	
LWF		06/12/2018	
CHECKED BY		DRAWING NUMBER	
		B K10341-001	
APPROVALS		SCALE: NONE SHEET 1 of 1	

THIS DRAWING IS CONFIDENTIAL PROPERTY OF SUNMODO AND ITS CONTENTS MAY NOT BE DISCLOSED WITHOUT THE PRIOR WRITTEN CONSENT OF SUNMODO CORP.

REVISIONS			
REV	DESCRIPTION	BY	DATE
A	INITIAL RELEASE	LWF	06/12/2018

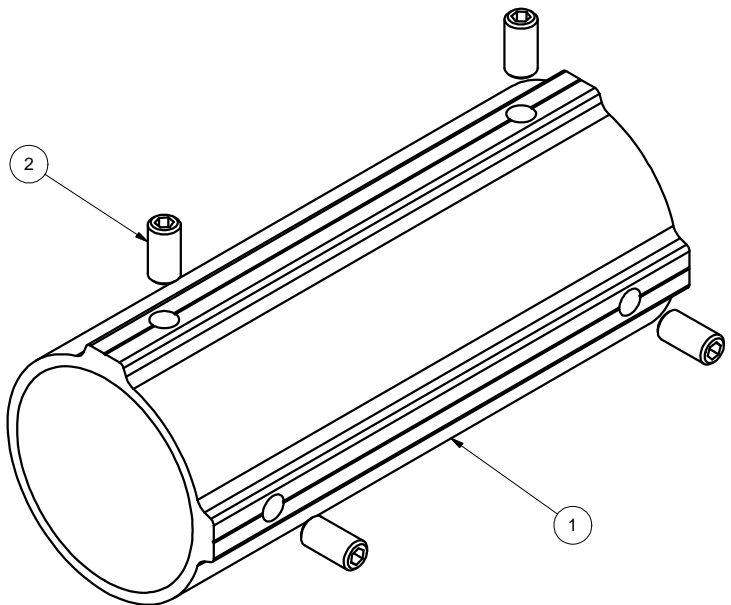

2	B10001-001	SET SCREW M10X20	4
1	A20328-001	2.5" PIPE SPLICE	1
ITEM	PART NUMBER	DESCRIPTION	QTY
MATERIAL		SEE NOTES	
Third Angle Projection:			
GENERAL SPECIFICATIONS		SunModo Corp. 14800 NE 65TH STREET, VANCOUVER WA 98682	
All Dimensions in inches [millimeters] Tolerances X.XXX ±0.01 [0.25mm] X.XX ±0.02 [0.50mm] X.X ±0.039 [1.0mm] Unless otherwise spec'd		Break all sharp edges .010-.020 unless otherwise specified.	
DRAWN BY		TITLE	
LWF		2.5" PIPE SPLICE KIT	
CHECKED BY		DRAWING NUMBER	
		B K10342-001	
APPROVALS		SCALE: NONE SHEET 1 of 1	

THIS DRAWING IS CONFIDENTIAL PROPERTY OF SUNMODO AND ITS CONTENTS MAY NOT BE DISCLOSED WITHOUT THE PRIOR WRITTEN CONSENT OF SUNMODO CORP.

NOTES: UNLESS OTHERWISE SPECIFIED

1. DIMENSIONS SHOWN ARE INCHES [MILIMETERS].
2. MATERIAL:HIGH STRENGTH STEEL PIPE OR TUBE.
3. FINISH: HOT DIP GALVANIZE PER ASTM A123 / A123M - 02.

MINIMUM 50 KSI YIELD STRESS.

4. BREAK ALL BURRS AND SHARP EDGES.

5. ALL WELDING MUST BE IN COMPLIANCE WITH AWS CODE D1;1.

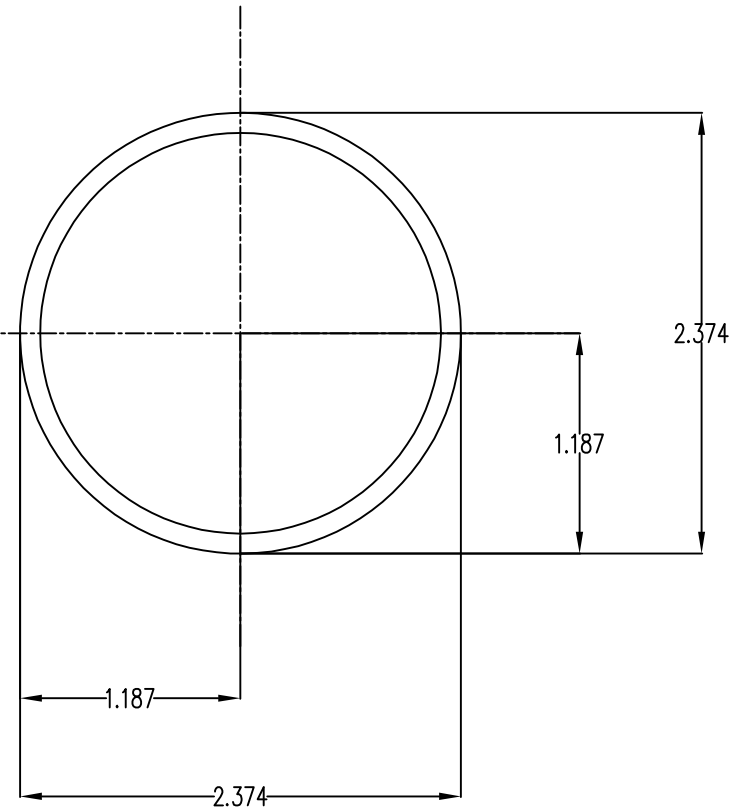

Section properties:

Weight: 2.641 lbs/ft

Area: 0.776 in²

Perimeter: 14.238 in

Bounding Box: X: -1.187,1.187

Y: -1.187,1.187

Centroid:(0.000,0.000)

Moments of Inertia(in⁴): I_x=0.499,I_y=0.499

Section modulus in bending(in³): W_x=0.420,W_y=0.420

Radii of Gyration: X: 0.802, Y: 0.802

MATERIAL		SEE NOTES		Sunmodo Corp. 14800 NE 85TH STREET, VANCOUVER WA 98682	
Third Angle Projection:					
GENERAL SPECIFICATIONS				TITLE	
All Dimensions in Inches (millimeters)				PIPE, HSS, 2.375" OD X 12 GAUGE,L=XXX	
Tolerances				Break all sharp edges .010-.020 unless otherwise specified.	
XXX ±0.01 (0.25mm)					
XX ±0.02 (0.50mm)					
X ±0.050 (1.2mm)					
Unless otherwise specified					
DRAWN BY		DATE		DRAWING NUMBER	
LWF		04/03/2019		A21165	
CHECKED BY				B	
APPROVALS				SCALE: NONE	
				SHEET 1 of 1	

NOTES: UNLESS OTHERWISE SPECIFIED

1. DIMENSIONS SHOWN ARE INCHES [MILIMETERS].
2. MATERAIL:HIGH STRENGTH STEEL PIPE OR TUBE.
3. FINISH: HOT DIP GALVANIZE PER ASTM A123 / A123M - 02.

MINIMUM 50 KSI YIELD STRESS.

4. BREAK ALL BURRS AND SHARP EDGES.
5. ALL WELDING MUST BE IN COMPLIANCE WITH AWS CODE D1;1.

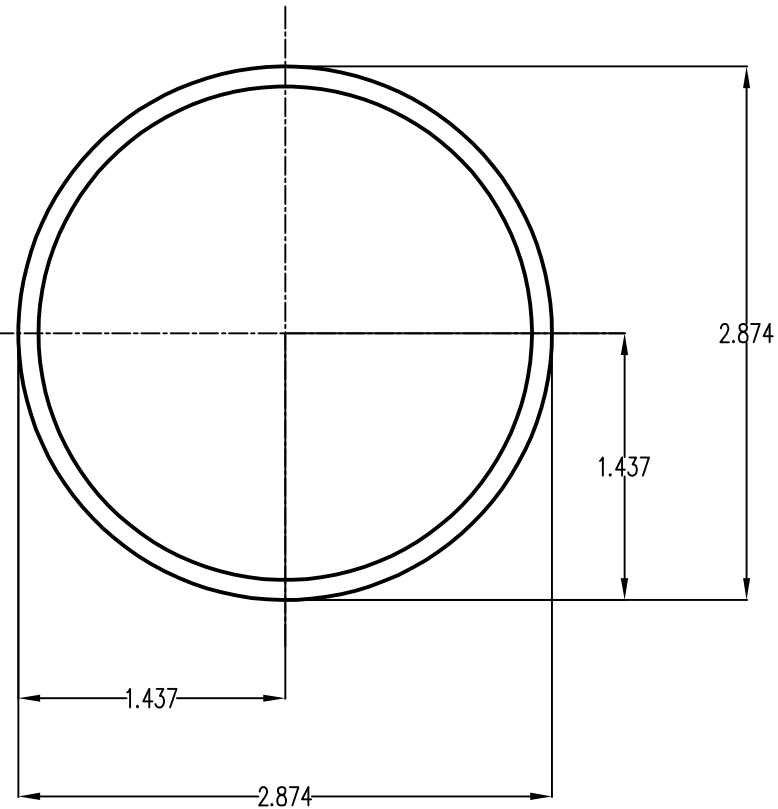

Section properties:

Weight: 3.201 lbs/ft

Area: 0.941 in²

Perimeter: 17.378 in

Bounding Box: X: -1.437,1.437

Y: -1.437,1.437

Centroid:(0.000,0.000)

Moments of Inertia(in⁴): Ix=0.901,Iy=0.901

Section modulus in bending(in³): Wx=0.627,Wy=0.627

Radii of Gyration: X: 0.979, Y: 0.979

MATERIAL		SEE NOTES		Sunmodo Corp.	
Third Angle Projection:					
GENERAL SPECIFICATIONS All Dimensions in Inches (millimeters)				TITLE	
Tolerances XXX ±0.01 (0.25mm) XX ±0.02 (0.50mm) X ±0.030 (1.0mm) Unless otherwise specified				PIPE, HSS, 2.875" OD X 12 GAUGE,L=XXX	
DRAWN BY LWF		DATE 04/03/2019		DRAWING NUMBER A21168	
CHECKED BY				B	
APPROVALS				SCALE: NONE	
				SHEET 1 of 1	