



Project Number: U2716-114-201

April 22, 2021

Sunmodo
14800 NE 65th Street
Vancouver, WA 98682

**REFERENCE: Sunmodo Sunturf Ground Mount A5
Ground Mount PV Array Installation**

To Whom It May Concern:

Per request of Sunmodo, we have been asked to prepare the structural design of a ground-mounted PV solar array system with several foundation options as shown in the attached calculations. The adopted building code in this jurisdiction is the 2018 International Building Code. Vector Structural Engineering requires that we review each site specific install, and we are not liable for installs at site specific locations we have not reviewed. The following design parameters are used in our analysis:

- Minimum Design Loads for Buildings and Other Structures (ASCE 7-16)
- Design wind speed for risk category I structures: 140 mph
- Wind exposure: B
- Ground snow load: 70 psf
- The ground screws and helical piers must be tested to 1.5 times uplift and 2.0 times lateral reactions found in the table below. A minimum of one ground screw or helical pier must be tested.

Load (ASD)	Value (lbs)	Factor of Safety	Test Value (lbs)
UPLIFT	2713	1.5	4070
LATERAL	1908	2	3816

Foundation concrete shall have a minimum compressive strength of 2500 psi at 28 days. Cement for all concrete shall be Type I or II with a minimum of 6% entrained air with a water/cement ratio of 0.50. Maximum aggregate size shall be 3/4". No special inspection of concrete strength is required.

Footings are designed based on an allowable soil bearing pressure of 1500 psf an allowable skin friction of 250 psf, an allowable lateral bearing pressure of 150 pcf, and a coefficient of friction of 0.3. Vector Structural Engineering strongly recommends independent soils testing be performed by a licensed geotechnical engineer to verify the assumed soil parameters.

All ground mounts are to be installed per manufacturer’s recommendations. The use of solar panel support span tables provided by the manufacturer is allowed only where the site conditions and solar panel configuration match the description of the span tables. Electrical engineering is beyond our scope. All work performed must be in accordance with accepted industry-wide methods and applicable safety standards. Vector Structural Engineering assumes no responsibility for improper installation of the solar panels.

Very truly yours,

VECTOR STRUCTURAL ENGINEERING, LLC
NC Firm License: COA #P-0742

Russell Emery, P.E.
NC License: 049874
Project Engineer

Enclosures

RNE/stb



04/22/2021

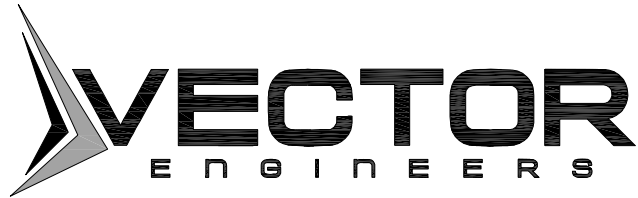

JOB NO. U2716-114-191
PROJECT SUNMODO SUNTURF GROUND MOUNTS A5
SUBJECT ALL OPTIONS

651 W GALENA PARK BLVD. #101 (801) 990-1775
DRAPER, UTAH 84020 (801) 990-1776 FAX

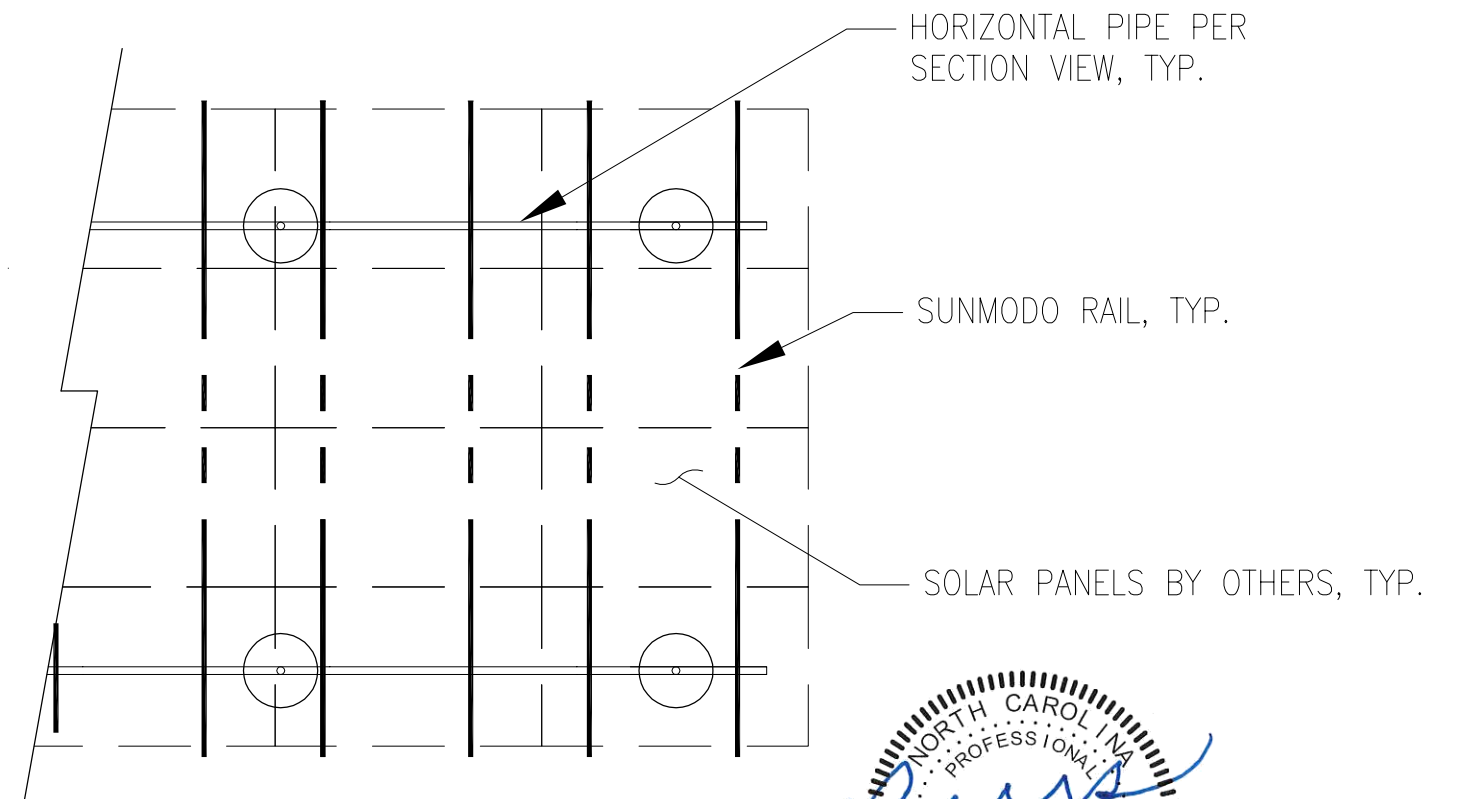
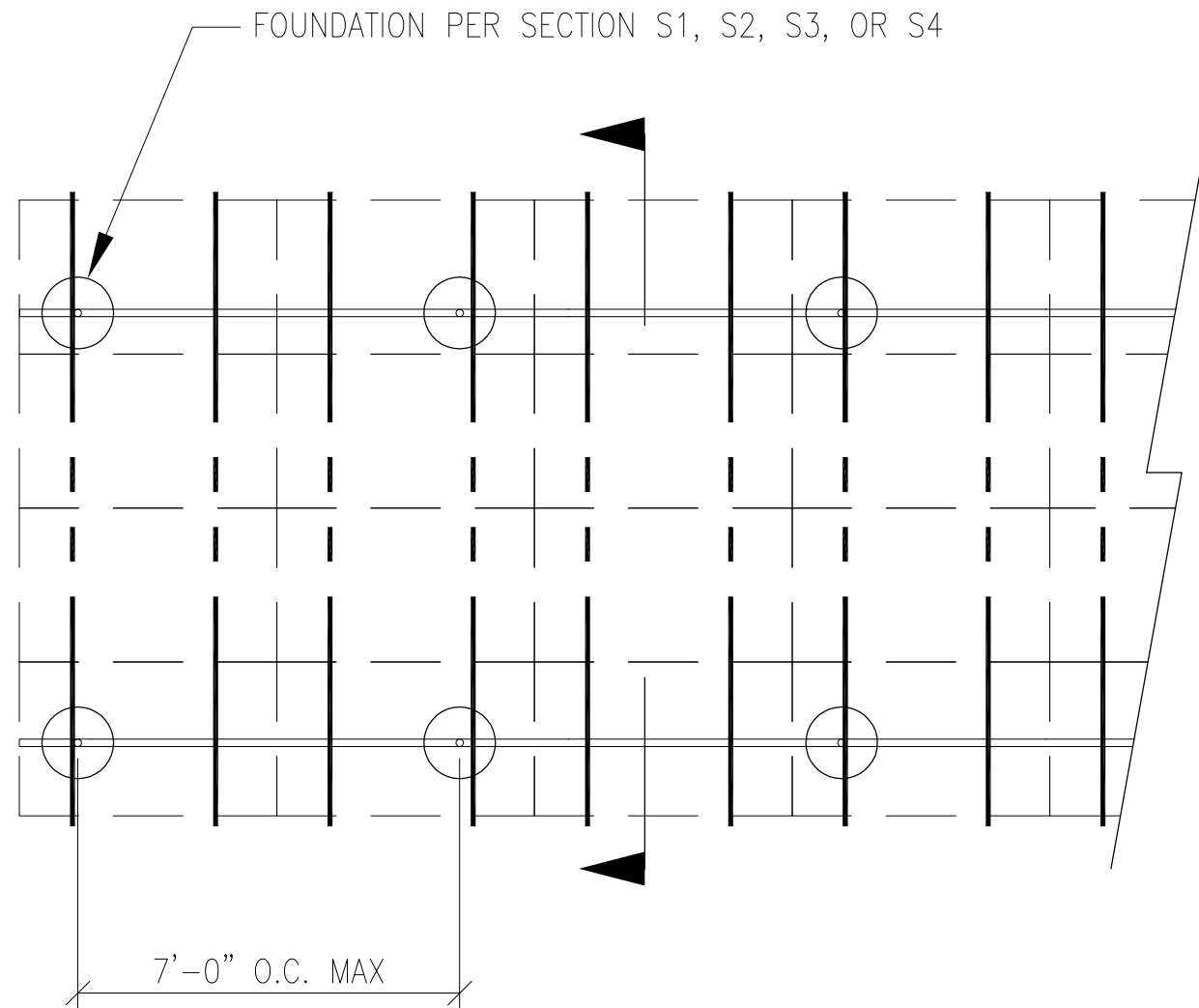

04/22/2021

PV ARRAY PLAN

N.T.S.

P1

PROJECT SUNMODO SUNTURF GROUND MOUNTS A5

SUBJECT DRILLED PIER OPTION

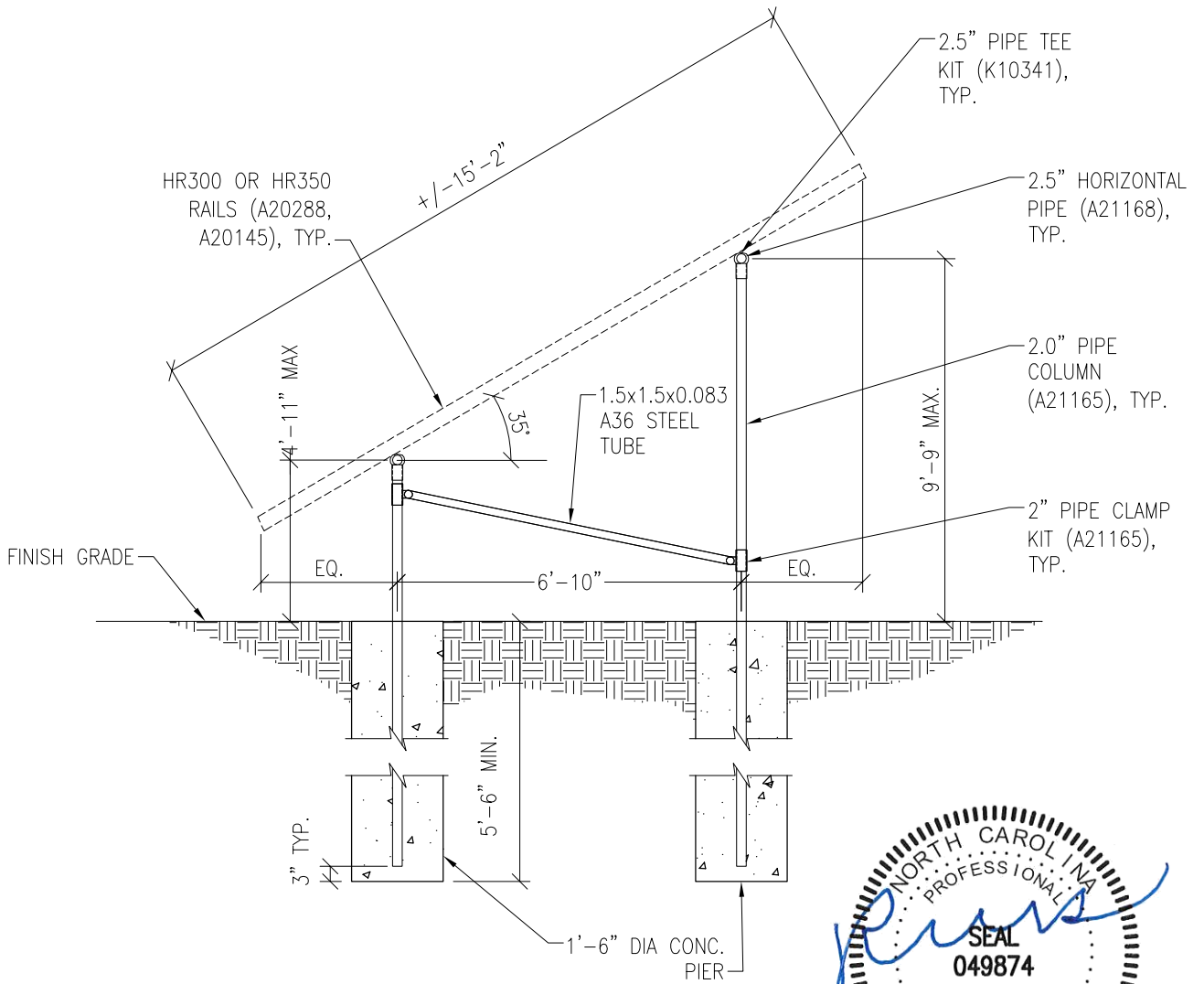

04/22/2021

Vector Engineers requires that we review each site specific install and is not liable for installs at site specific locations we have not reviewed.

PV ARRAY SECTION

N.T.S.

S1

PROJECT SUNMODO SUNTURF GROUND MOUNTS A5

SUBJECT HELICAL PIER OPTION

NOTES:

1. For ground mount components see Section S1.
2. A minimum of (1) helical pier must be load-tested as follows:
 - 2.1. Safety factor for uplift = 1.5,
 - 2.2. Safety factor for lateral loads = 2.0
 - 2.3. Upward deflection limit = 1/2"
 - 2.4. Lateral deflection limit = 1"
 - 2.5. The load tests must be performed by an approved contractor.

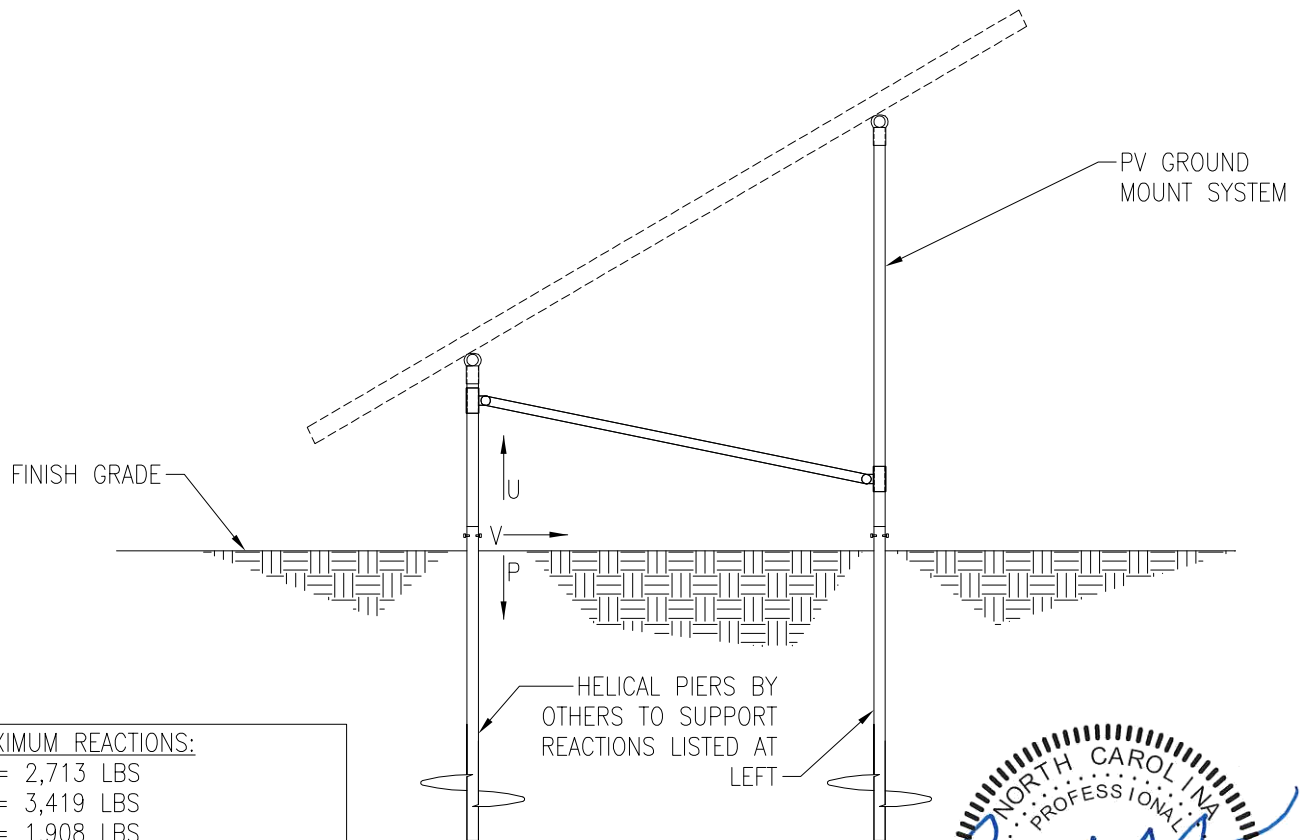

MAXIMUM REACTIONS:	
U	= 2,713 LBS
P	= 3,419 LBS
V	= 1,908 LBS



04/22/2021

Vector Engineers requires that we review each site specific install and is not liable for installs at site specific locations we have not reviewed.

PV ARRAY SECTION

N.T.S.



JOB NO. U2716-114-191

PROJECT SUNMODO SUNTURF GROUND MOUNTS A5

SUBJECT GROUND SCREW OPTION

NOTES:

- 1. For ground mount components see Section S1.
- 2. A minimum of (1) ground screw must be load-tested as follows:
 - 2.1. Safety factor for uplift = 1.5,
 - 2.2. Safety factor for lateral loads = 2.0
 - 2.3. Upward deflection limit = 1/2"
 - 2.4. Lateral deflection limit = 1"
 - 2.5. The load tests must be performed by an approved contractor.

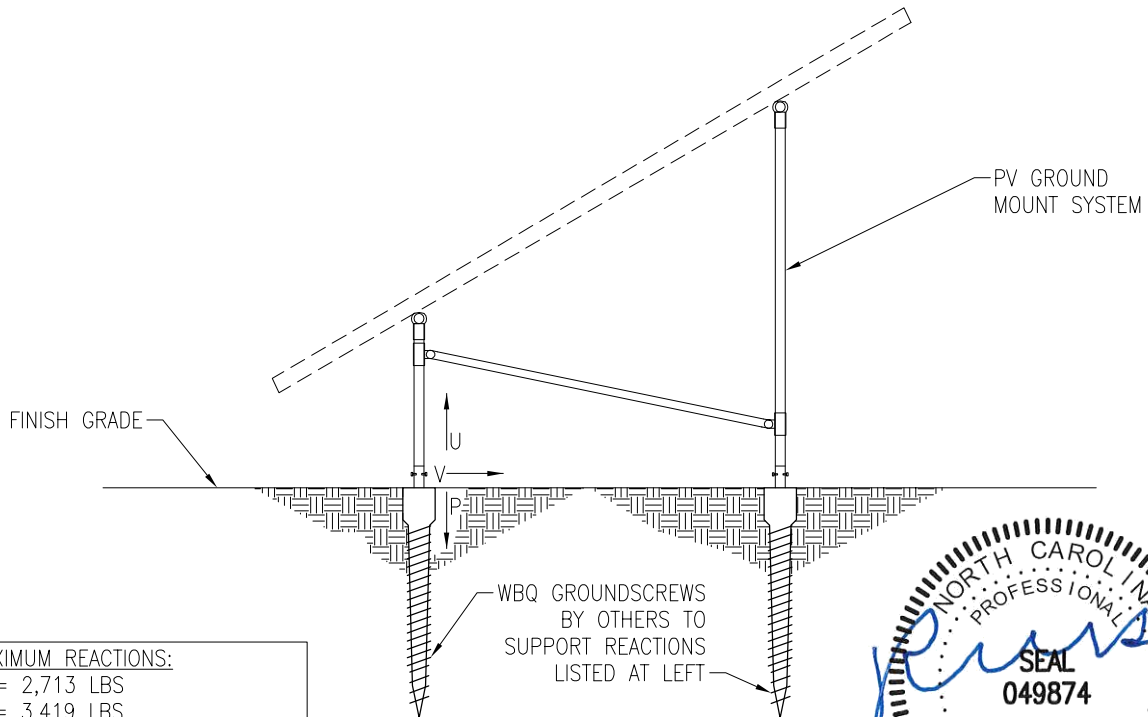

MAXIMUM REACTIONS:
 U = 2,713 LBS
 P = 3,419 LBS
 V = 1,908 LBS



04/22/2021

Vector Engineers requires that we review each site specific install and is not liable for installs at site specific locations we have not reviewed.

PV ARRAY SECTION

N.T.S.

S3

651 W GALENA PARK BLVD. #101
DRAPER, UTAH 84020

(801) 990-1775
(801) 990-1776 FAX

WWW.VECTORSE.COM



JOB NO. U2716-114-191

PROJECT SUNMODO SUNTURF GROUND MOUNTS A5

SUBJECT BALLASTED BLOCK OPTION

NOTES:

1. For ground mount components see Section S1.

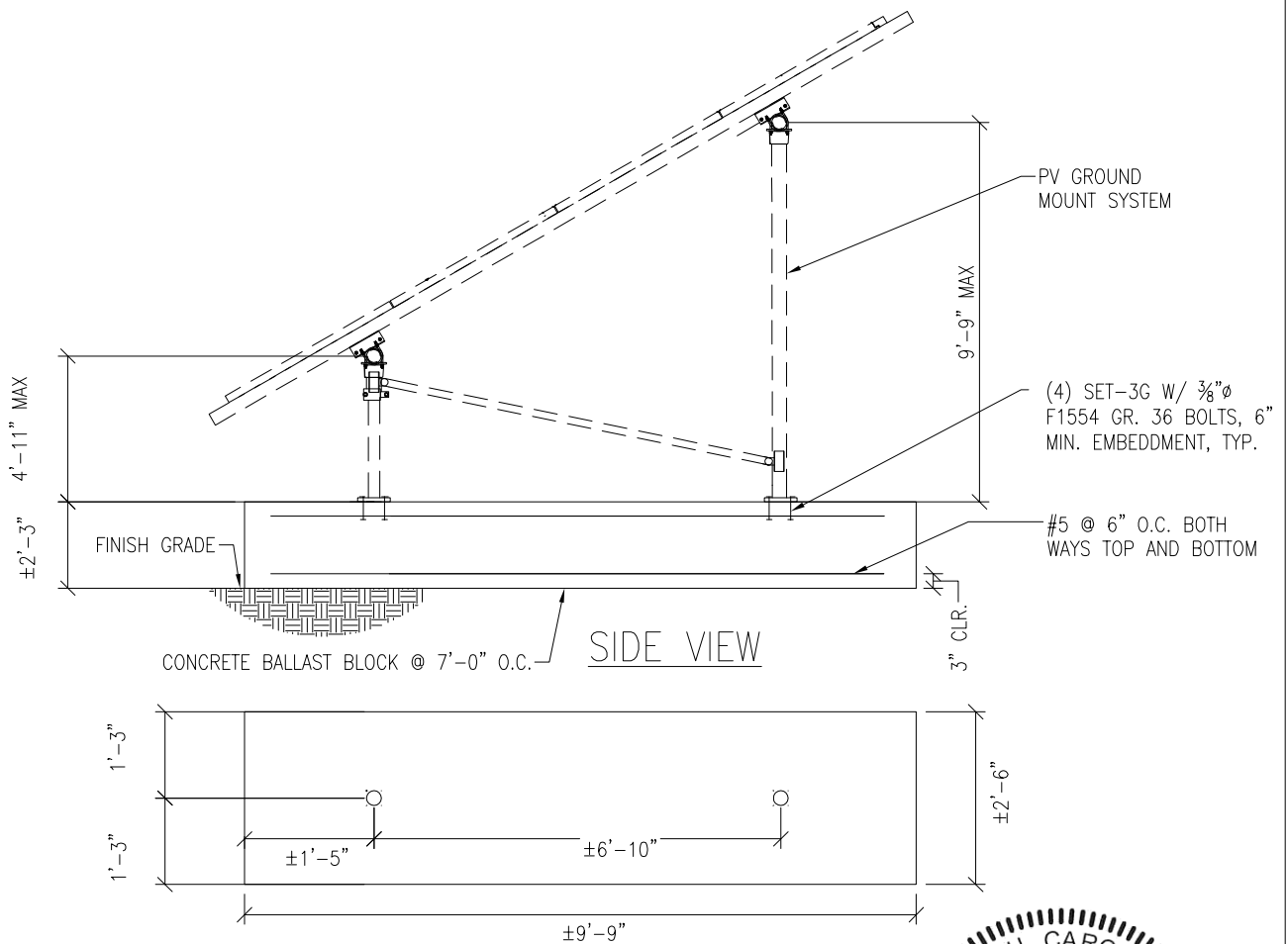

Vector Engineers requires that we review each site specific install and is not liable for installs at site specific locations we have not reviewed.

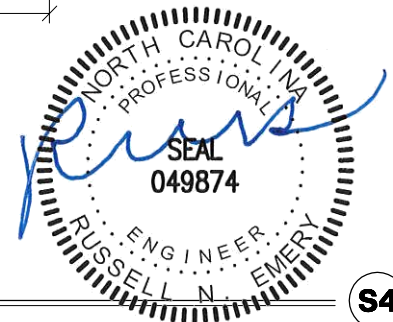

PV ARRAY SECTION

N.T.S.

S4

651 W GALENA PARK BLVD. #101
 DRAPER, UTAH 84020

(801) 990-1775
 (801) 990-1776 FAX

04/22/2021

WWW.VECTORSE.COM

PROJECT: A5 – Sunmodo Sunturf GM

SUBJECT: Dead Load

Design Weight:

Individual Panel Weight [lb]:	50.7
Panel Transverse Length (T5) [in]:	41.2
Panel Transverse Length (T5) [ft]:	3.4
Panel Longitudinal Length (L2) [in]:	81.4
Panel Longitudinal Length (L2) [ft]:	6.8
Individual Panel Area [ft ²]:	23.3
Individual Panel Weight [psf]:	2.2
# of Panels in Transverse Direction:	4
Approximate Transverse Length (T4) [ft]:	13.7
# of Panels in Longitudinal Direction:	12
Approximate Longitudinal Length (L1) [ft]:	81.4
Transverse Column Spacing (T1) [ft]:	6.7
Longitudinal Column Spacing (L3) [ft]:	7.0
# of Columns in Longitudinal Direction:	12
# of Columns in Transverse Direction:	2
Total Number of Columns:	24
Panel Slope from Horizontal (a) [°]:	35.0
Short Column Height (H1) [ft]:	4.5
Approximate Tall Column Height (H2) [ft]:	9.2
Transverse Brace between Columns :	Yes
Approximate Brace Length (B1) [ft]:	9.0
Weight of Columns [plf]:	3.7
Weight of Cross Pipe [plf]:	3.7
Weight of Brace [plf]:	3.7
Tributary Transverse Length per Column [ft]:	6.9
Tributary Longitudinal Length per Column [ft]:	7.0
Tributary Area per Column [ft ²]:	48.1
Rail Weight [plf]:	1.0
Transverse Rail Weight per Column [lb]:	27.5
Longitudinal Rail Weight per Column [lb]:	25.6
Tall Column Weight [lb]:	33.6
Panel Weight per Column [lb]:	104.6
Rail Weight per Column [lb]:	27.5
Cross Pipe Weight per Column [lb]:	25.6
Brace Weight per Column [lb]:	16.4
Total Weight per Column (1.0 D) [lb]:	207.7

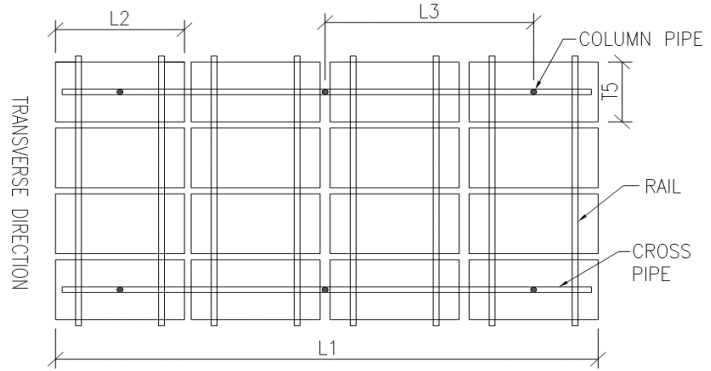

ILLUSTRATION ONLY

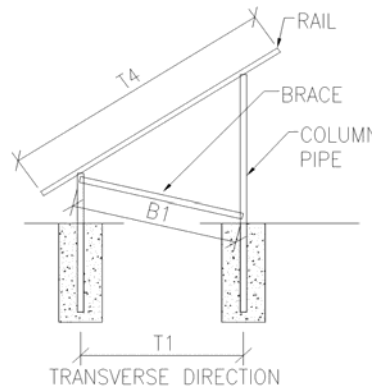

ILLUSTRATION ONLY

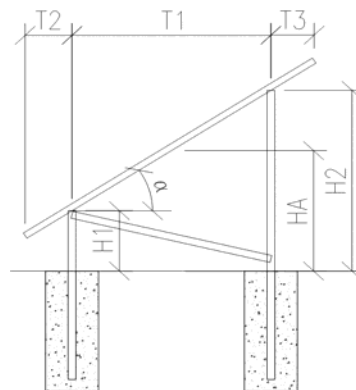

ILLUSTRATION ONLY

Assumptions:

- T2 = T3



JOB NO.: U2716-114-191

DESIGNED: STB

DATE: 08/01/19

PROJECT: A5 – Sunmodo Sunturf GM

SUBJECT: Snow Load

SNOW LOAD (S):

ASCE 7 Standard:	10	
Panel Slope from Horizontal [°]:	35.0	
Snow Ground Load, p_g [psf]:	70.0	(Section 7.2)
Terrain Category:	B	(Table 7-2)
Exposure of Roof:	Fully Exposed	(Table 7-2)
Exposure Factor, C_e :	0.9	(Table 7-2)
Thermal Factor, C_t :	1.2	(Table 7-3)
Risk Category:	I	(Table 1.5-1)
Importance Factor, I_s :	0.8	(Table 1.5-2)
Flat Roof Snow Load, p_f [psf]:	42	(Equation 7.3-1)
Minimum Roof Snow Load, p_m [psf]:	0	(Section 7.3.4)
Unobstructed Slippery Surface?	Yes	(Section 7.4)
Slope Factor Figure:	Figure 7-2c	(Section 7.4)
Roof Slope Factor, C_s :	0.636	(Figure 7-2)
Sloped Roof Snow Load, p_s [psf]:	27	(Equation 7.4-1)
Design Snow Load, S [psf]:	27	
Tributary Transverse Length [ft]:	5.6	
Tributary Longitudinal Length [ft]:	7	
Tributary Area per Column [ft ²]:	39.4	
Snow Load per Column (1.0 S) [lb]:	1060.8	



PROJECT: A5 – Sunmodo Sunturf GM

SUBJECT: Wind Pressure

Design Wind Load:

ASCE 7 Standard:	10	
Basic Wind Speed, V [mph]:	140	
Risk Category:	I	
Exposure Category	B	(Section 26.7.3)
Velocity Pressure Exposure Coefficient, K_h :	0.57	(Table 27.3-1)
Topographic Factor, K_{ht} :	1.0	(Section 26.8.2)
Wind Directionality Factor, K_d :	0.85	(Table 26.6-1)
Internal Pressure Coefficient, GC_{pi} :	0.00	(Table 26.11-1)
Velocity Pressure, q_h [psf]:	24.3	(Equation 27.3-1)
Gust Effect Factor, G:	0.85	(Section 26.9.1)
Panel Slope [degrees]:	35.0	

Net Pressure Coefficients (C_N) per: (Figure 27.4-4)

Clear Wind Flow	C_{NW}	C_{NL}
Case 1 ($\gamma = 0^\circ$, Load Case A)	-1.80	-1.80
Case 2 ($\gamma = 0^\circ$, Load Case B)	-2.43	-0.57
Case 3 ($\gamma = 180^\circ$, Load Case A)	2.10	2.17
Case 4 ($\gamma = 180^\circ$, Load Case B)	2.67	1.07

Design Wind Pressures (p) [psf] per: (Equation 27.4-3)

Clear Wind Flow	$q_h GC_{NW}$	$q_h GC_{NL}$
Case 1 ($\gamma = 0^\circ$, Load Case A)	-37.2	-37.2
Case 2 ($\gamma = 0^\circ$, Load Case B)	-50.3	-11.7
Case 3 ($\gamma = 180^\circ$, Load Case A)	43.4	44.8
Case 4 ($\gamma = 180^\circ$, Load Case B)	55.1	22.0

Wind Pressure on Each Side of Panels [psf]

Clear Wind Flow	Short Col. Pressure	Long Col. Pressure
Case 1 ($\gamma = 0^\circ$, Load Case A)	-37.2	-37.2
Case 2 ($\gamma = 0^\circ$, Load Case B)	-11.7	-50.3
Case 3 ($\gamma = 180^\circ$, Load Case A)	43.4	44.8
Case 4 ($\gamma = 180^\circ$, Load Case B)	55.1	22.0



JOB NO.: U2716-114-191

PROJECT: A5 – Sunmodo Sunturf GM

SUBJECT: Open Building Wind Loads

Design Wind Load Per ASCE 7-10

$$p = q_h G C_n$$

Velocity Pressure Exposure Coefficient, K_{zt} :	0.57	(Table 27.3-1)
Topographic Factor, K_{ht} :	1.0	(Section 26.8.2)
Wind Directionality Factor, K_d :	0.85	(Table 26.6-1)
Ultimate Wind Speed, V [mph]:	140	

Velocity Pressure, q_h [psf]:	24.3	(Equation 27.3-1)
Gust Effect Factor, G :	0.85	(Section 26.9.1)

$\gamma = 90^\circ$ or 270°

Force Coefficient, C_N :

Horizontal Distance from Winward Edge	Roof angle		
	Load Case	Obstructed Wind Flow	
		CN	
$\leq h$	35	A	-0.8
		B	0.8
$> h, \leq 2h$	35	A	-0.6
		B	0.5
$> 2h$	35	A	-0.3
		B	0.3

Design Wind Pressure, p [psf]:

Horizontal Distance from Winward Edge	Roof angle		
	Load Case	Obstructed Wind Flow	
$\leq h$	35	A	-16.5
		B	16.5
$> h, \leq 2h$	35	A	-12.4
		B	10.3
$> 2h$	35	A	-6.2
		B	6.2



JOB NO.: U2716-114-191

DESIGNED: STB

Foundation Option 1: Drilled Concrete Pier



PROJECT: A5 - Sunturf Ground Mount

DRILLED CONCRETE PIER DESIGN

Column Reactions:

Max. Shear, V [k]:	1.9	Max. Down, P _d [k]:	3.4
Max. Moment, M [k-ft]:	0.0	Max. Uplift, P _u [k]:	2.7

Pier Properties:

Pier Shape:	Round	Volume of Concrete [ft ³]:	10
Pier Diameter, b [ft]:	1.5	Volume of Concrete [yd ³]:	0.4
Top of Pier Elevation [ft]:	0.00	Weight of Concrete [k]:	1.5
Pier Depth, d [ft]:	5.5		

Soil Properties:

Allow. Bearing Pressure [psf]:	1,500	<u>Optional Parameters for Uplift:</u>	
1/3 increase for short term loads?	No	Skin Friction* [psf]:	250
Lateral Bearing, S [pcf]:	150	Top Length to Ignore [ft]:	0
Max. Lateral Bearing (opt'l) [psf]:		1/3 increase for short term loads?	No
Top Depth to Ignore [ft]:	0	Combine w/ Bearing:	No
1/3 increase for short term loads?	No		
1/2" deflection at t/o pier allowed:	Yes		

*per IBC Section 1810.3.3.1.4

Check Bearing:

Bearing Capacity [k]:	6.5
-----------------------	-----

Bearing capacity OK.

Check Uplift:

Uplift Capacity [k]:	7.8
----------------------	-----

Uplift capacity OK.

Check Lateral Bearing:

Top of Pier Constrained?:	No	IBC Section 1807.3.2.1
Applied Lateral Force, P [lb]:	1,908	
Point of Application, h [ft]:	0.0	
S _{max} [psf]:		
S [psf]:	550	
A = 2.34*P/(Sb):	5.41	
Required Pier Depth, d _{reqd} [ft]:	5.40	IBC Eq. 18-1

Result: **Lateral bearing capacity OK.**

Foundation Option 2: Helical Pier

The ground screws and helical piers must be tested to 1.5 times uplift and 2.0 times lateral reactions found in the table below.

Load (ASD)	Value (lbs)	Factor of Safety	Test Value (lbs)
UPLIFT	2713	1.5	4070
LATERAL	1908	2	3816

Foundation Option 3: Ground Screw

The ground screws and helical piers must be tested to 1.5 times uplift and 2.0 times lateral reactions found in the table below.

Load (ASD)	Value (lbs)	Factor of Safety	Test Value (lbs)
UPLIFT	2713	1.5	4070
LATERAL	1908	2	3816



JOB NO.: U2716-114-191

DESIGNED: STB

Foundation Option 4: Ballasted Block

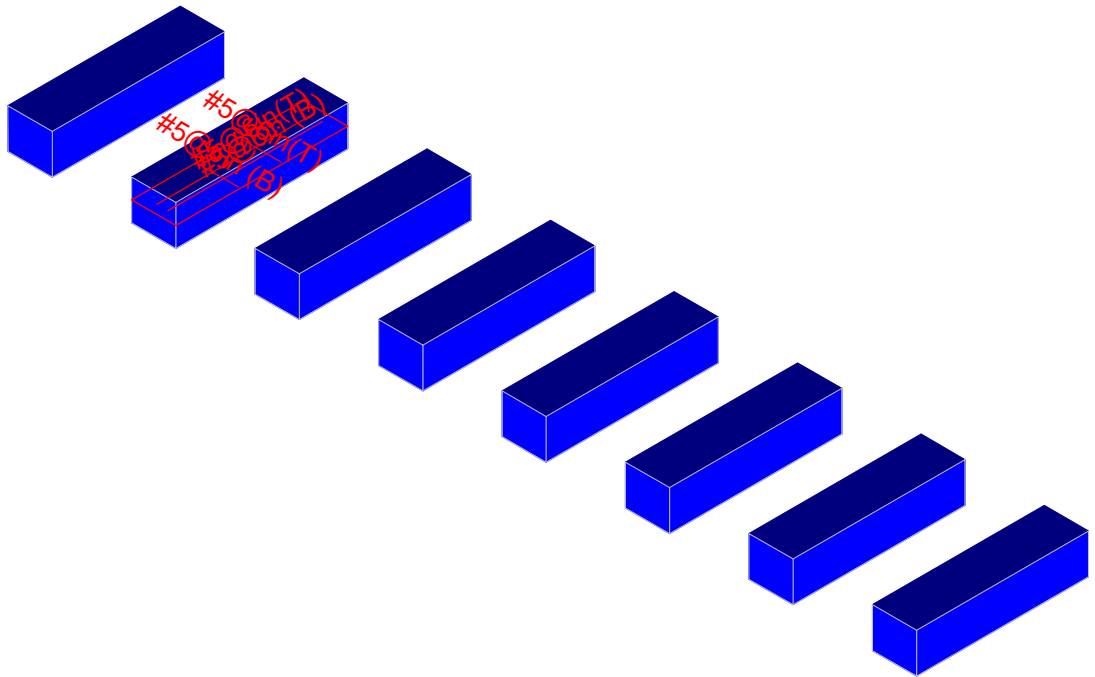

Results for LC 1, 1.0 D

Vector Structural Engineeri...	Ground Mount	SK - 2
STB		Apr 6, 2021 at 2:19 PM
U2716.114.181		Sunmodo Sunturf A5 v3 85x45.r3d

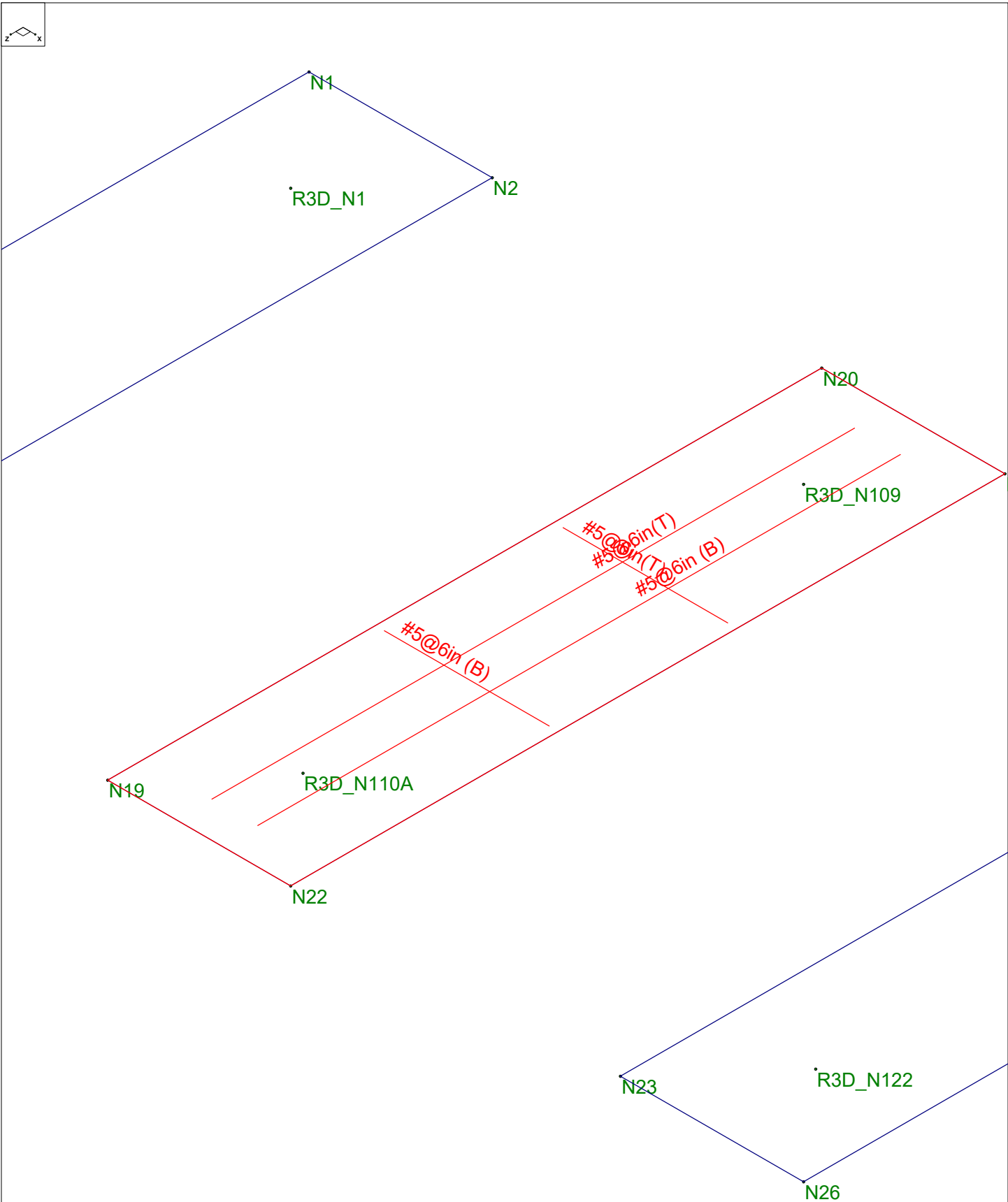

Results for LC 1, 1.0 D

Vector Structural Engineeri...	Ground Mount	SK - 1
STB		Apr 6, 2021 at 2:19 PM
U2716.114.181		Sunmodo Sunturf A5 v3 85x45.r3d



(Global) Model Settings

Display Sections for Member Calcs	5
Max Internal Sections for Member Calcs	100
Mesh Size (in)	12
Max Iterations	10
Merge Tolerance (in)	.12
Solver	Sparse Accelerated
Coefficient of Friction	.3
No. of Shear Regions	4
Shear Region Spacing Increment (in)	4
Min 1 Bar Dia Spacing for Beams?	No
Optimize footings for OTM / Sliding?	Yes
Parme Beta Factor	.65
Pile Safety Factor	3
Concrete Stress Block	0
Concrete Rebar Set	Rectangular
Concrete Code	ASTM A615
HR Steel Pile Code	ACI 318-14
Wood Pile Code	AISC 14th (360-10): ASD AWC NDS-15: ASD

Concrete Properties

	Label	E [ksi]	G [ksi]	Nu	Therm (/...	Density[lb/ft^3]	fc[psi]	Lambda	Flex Stee...	Shear St...
1	Conc3000NW	3156	1372	.15	.6	145	3000	1	60000	60000
2	Conc3500NW	3409	1482	.15	.6	145	3500	1	60000	60000
3	Conc4000NW	3644	1584	.15	.6	145	4000	1	60000	60000
4	Conc3000LW	2085	907	.15	.6	109.999	3000	.75	60000	60000
5	Conc3500LW	2252	979	.15	.6	109.999	3500	.75	60000	60000
6	Conc4000LW	2408	1047	.15	.6	109.999	4000	.75	60000	60000
7	Conc2500NW	3156	1372	.15	.6	145	2500	1	60000	60000

General Design Parameters

	Label	Max Bending Chk	Max Shear Chk	Top Cover[in]	Bottom Cover[in]
1	Typical	1	1	3	3

Slab Rebar Parameters

	Label	Top Bar	Bottom Bar	Max Top Bar Sp...	Min Top Bar Sp...	Max Bot Bar Sp...	Min Bot Bar Sp...	Spacing Incr...	Rebar Options
1	Typical	#5	#5	6	6	6	6	1	Optimize

Soil Definitions

	Label	Subgrade Modulus[lb/ft^3]	Allowable Bearing[psf]	Depth Properties	Default?
1	Default	1e+5	1500	None	Yes

Point Loads and Moments (Cat 1 : DL)

	Label	Direction	Magnitude[lb,lb-ft]
1	R3D_N1	X	-12.871
2	R3D_N1	Y	139.156
3	R3D_N2_1	X	-8.429
4	R3D_N2_1	Y	110.78
5	R3D_N132	Y	223.018
6	R3D_N133	Y	224.358
7	R3D_N109	Y	227.515
8	R3D_N110A	X	1.788

Point Loads and Moments (Cat 16 : OL1) (Continued)

	Label	Direction	Magnitude[lb.-ft]
9	R3D_N133	X	2.14
10	R3D_N133	Y	754.034
11	R3D_N133	Z	-101.89
12	R3D_N109	Y	-4269.345
13	R3D_N109	Z	2679.911
14	R3D_N110A	X	-17.56
15	R3D_N110A	Y	898.769
16	R3D_N110A	Z	-98.9
17	R3D_N121	Y	-3890.841
18	R3D_N121	Z	2277.093
19	R3D_N122	X	1.962
20	R3D_N122	Y	702.14
21	R3D_N122	Z	-99.77
22	R3D_N133B_1	Y	-3978.749
23	R3D_N133B_1	Z	2368.037
24	R3D_N134B	X	-1.017
25	R3D_N134B	Y	755.343
26	R3D_N134B	Z	-101.867
27	R3D_N151	Y	-3896.738
28	R3D_N151	Z	2283.071
29	R3D_N152	Y	708.4
30	R3D_N152	Z	-100.003
31	R3D_N143A_1	Y	-4260.197
32	R3D_N143A_1	Z	2668.532
33	R3D_N144A_1	X	19.185
34	R3D_N144A_1	Y	891.333
35	R3D_N144A_1	Z	-99.336
36	R3D_N149A	X	-124.023
37	R3D_N149A	Y	-1960.772
38	R3D_N149A	Z	1065.859
39	R3D_N150A	X	-43.725
40	R3D_N150A	Y	286.818
41	R3D_N150A	Z	-62.844

Point Loads and Moments (Cat 17 : OL2)

	Label	Direction	Magnitude[lb.-ft]
1	R3D_N1	X	169.199
2	R3D_N1	Y	-2078.523
3	R3D_N1	Z	819.949
4	R3D_N2_1	X	-13.185
5	R3D_N2_1	Y	701.13
6	R3D_N2_1	Z	-50.463
7	R3D_N132	Y	-4477.953
8	R3D_N132	Z	1994.168
9	R3D_N133	X	1.925
10	R3D_N133	Y	1762.748
11	R3D_N133	Z	-85.859
12	R3D_N109	X	-1.366
13	R3D_N109	Y	-4774.391
14	R3D_N109	Z	2262.693
15	R3D_N110A	X	-6.195
16	R3D_N110A	Y	2009.287
17	R3D_N110A	Z	-83.398
18	R3D_N121	Y	-4391.569
19	R3D_N121	Z	1917.146
20	R3D_N122	Y	1692.903

Point Loads and Moments (Cat 18 : OL3) (Continued)

	Label	Direction	Magnitude[lb.-ft]
32	R3D_N143A_1	Y	5094.418
33	R3D_N143A_1	Z	-3164.446
34	R3D_N144A_1	X	-22.461
35	R3D_N144A_1	Y	-1102.26
36	R3D_N144A_1	Z	117.794
37	R3D_N149A	X	149.281
38	R3D_N149A	Y	2346.638
39	R3D_N149A	Z	-1263.905
40	R3D_N150A	X	50.227
41	R3D_N150A	Y	-359.236
42	R3D_N150A	Z	74.523

Point Loads and Moments (Cat 19 : OL4)

	Label	Direction	Magnitude[lb.-ft]
1	R3D_N1	X	-77.326
2	R3D_N1	Y	1391.854
3	R3D_N1	Z	-1004.569
4	R3D_N2_1	X	-81.327
5	R3D_N2_1	Y	151.839
6	R3D_N2_1	Z	61.614
7	R3D_N132	Y	3124.29
8	R3D_N132	Z	-2433.859
9	R3D_N133	X	-2.096
10	R3D_N133	Y	191.353
11	R3D_N133	Z	104.772
12	R3D_N109	Y	3381.027
13	R3D_N109	Z	-2751.926
14	R3D_N110A	X	25.433
15	R3D_N110A	Y	149.349
16	R3D_N110A	Z	101.648
17	R3D_N121	Y	3046.586
18	R3D_N121	Z	-2342.95
19	R3D_N122	X	-3.828
20	R3D_N122	Y	222.32
21	R3D_N122	Z	102.592
22	R3D_N133B_1	Y	3125.239
23	R3D_N133B_1	Z	-2434.755
24	R3D_N134B	X	1.591
25	R3D_N134B	Y	190.339
26	R3D_N134B	Z	104.746
27	R3D_N151	Y	3051.159
28	R3D_N151	Z	-2347.257
29	R3D_N152	X	3.453
30	R3D_N152	Y	217.424
31	R3D_N152	Z	102.808
32	R3D_N143A_1	Y	3373.946
33	R3D_N143A_1	Z	-2743.034
34	R3D_N144A_1	X	-26.562
35	R3D_N144A_1	Y	154.412
36	R3D_N144A_1	Z	102.161
37	R3D_N149A	X	75.258
38	R3D_N149A	Y	1507.672
39	R3D_N149A	Z	-1096.347
40	R3D_N150A	X	83.337
41	R3D_N150A	Y	157.135
42	R3D_N150A	Z	64.589



Point Loads and Moments (Cat 21 : OL6) (Continued)

	Label	Direction	Magnitude [lb.-ft]
10	R3D N133	Y	122.263
11	R3D N133	Z	-17.49
12	R3D N109	X	-5.693
13	R3D N109	Y	-1589.272
14	R3D N109	Z	989.609
15	R3D N110A	X	-17.849
16	R3D N110A	Y	357.342
17	R3D N110A	Z	-34.321
18	R3D N121	X	-1.79
19	R3D N121	Y	-952.579
20	R3D N121	Z	551.6
21	R3D N122	X	2.364
22	R3D N122	Y	160.389
23	R3D N122	Z	-25.421
24	R3D N133B 1	X	-2.252
25	R3D N133B 1	Y	-669.635
26	R3D N133B 1	Z	402.389
27	R3D N134B	Y	133.567
28	R3D N134B	Z	-19.369
29	R3D N151	X	-1.967
30	R3D N151	Y	-655.498
31	R3D N151	Z	381.809
32	R3D N152	Y	118.976
33	R3D N152	Z	-16.823
34	R3D N143A 1	X	-2.67
35	R3D N143A 1	Y	-687.431
36	R3D N143A 1	Z	445.329
37	R3D N144A 1	X	2.659
38	R3D N144A 1	Y	150.654
39	R3D N144A 1	Z	-16.599
40	R3D N149A	X	-34.946
41	R3D N149A	Y	-353.501
42	R3D N149A	Z	176.75
43	R3D N150A	X	-6.955
44	R3D N150A	Y	50.778
45	R3D N150A	Z	-10.465

Slabs

	Label	Thickness [in]	Material	Local Axis Angle ...	Analysis Offset [in]	Passive Pressur...	Soil Overburden [psf]
1	S1	27	Conc2500NW	0	0	0	0
2	S2	27	Conc2500NW	0	0	0	0
3	S3	27	Conc2500NW	0	0	0	0
4	S4	27	Conc2500NW	0	0	0	0
5	S5	27	Conc2500NW	0	0	0	0
6	S6	27	Conc2500NW	0	0	0	0
7	S7	27	Conc2500NW	0	0	0	0
8	S8	27	Conc2500NW	0	0	0	0

Load Combinations

	Label	Solve	Service A...	SF	Cat..Fa...	Cat..Fa...	Cat..Fa...	Cat..Fa...	Cat..Fa...	Cat..Fa...	Cat..Fa...	Cat..Fa...	Cat..Fa...	C...	F...	C...	F...
1	1.0 D	Yes	Yes	1.5	DL	1											
2	1.0 D + 1....	Yes	Yes	1.5	DL	1	RLL	1									
3	1.0 D + 0....	Yes	Yes	1.5	DL	1	RLL		OL1	.6							
4	1.0 D + 0....	Yes	Yes	1.5	DL	1	RLL		OL2	.6							
5	1.0 D + 0....	Yes	Yes	1.5	DL	1	RLL		OL3	.6							
6	1.0 D + 0....	Yes	Yes	1.5	DL	1	RLL		OL4	.6							

Load Combinations (Continued)

Label	Solve	Service	A...	SF	Cat..	Fa...	Cat..	Fa...	Cat..	Fa...	Cat..	Fa...	Cat..	Fa...	Cat..	Fa...	Cat..	Fa...
7	1.0 D + 0....	Yes	Yes	1.5	DL	1	RLL		OL5	.6								
8	1.0 D + 0....	Yes	Yes	1.5	DL	1	RLL		OL6	.6								
9	1.0 D + 0....	Yes	Yes	1.5	DL	1	RLL	.75	OL1	.45								
10	1.0 D + 0....	Yes	Yes	1.5	DL	1	RLL	.75	OL2	.45								
11	1.0 D + 0....	Yes	Yes	1.5	DL	1	RLL	.75	OL3	.45								
12	1.0 D + 0....	Yes	Yes	1.5	DL	1	RLL	.75	OL4	.45								
13	1.0 D + 0....	Yes	Yes	1.5	DL	1	RLL	.75	OL5	.45								
14	1.0 D + 0....	Yes	Yes	1.5	DL	1	RLL	.75	OL6	.45								
15	0.9 D + 0....	Yes	Yes		DL	.9	RLL		OL1	.6								
16	0.9 D + 0....	Yes	Yes		DL	.9	RLL		OL2	.6								
17	0.9 D + 0....	Yes	Yes		DL	.9	RLL		OL3	.6								
18	0.9 D + 0....	Yes	Yes		DL	.9	RLL		OL4	.6								
19	0.9 D + 0....	Yes	Yes		DL	.9	RLL		OL5	.6								
20	0.9 D + 0....	Yes	Yes		DL	.9	RLL		OL6	.6								
21																		
22	1.4D	Yes			DL	1.4												
23	1.2D+1.6SL	Yes			DL	1.2	RLL	1.6										
24	1.2D+1.6S...	Yes			DL	1.2	RLL	1.6	OL1	.5								
25	1.2D+1.6S...	Yes			DL	1.2	RLL	1.6	OL2	.5								
26	1.2D+1.6S...	Yes			DL	1.2	RLL	1.6	OL3	.5								
27	1.2D+1.6S...	Yes			DL	1.2	RLL	1.6	OL4	.5								
28	1.2D+1.6S...	Yes			DL	1.2	RLL	1.6	OL5	.5								
29	1.2D+1.6S...	Yes			DL	1.2	RLL	1.6	OL6	.5								
30	1.2D+1.0...	Yes			DL	1.2			OL1	1								
31	1.2D-1.0Wx	Yes			DL	1.2			OL2	1								
32	1.2D+1.0...	Yes			DL	1.2			OL3	1								
33	1.2D-1.0Wz	Yes			DL	1.2			OL4	1								
34	1.2D+1.0...	Yes			DL	1.2			OL5	1								
35	1.2D-1.0...	Yes			DL	1.2			OL6	1								
36	1.0D+1.0...	Yes			DL	1			OL1	1								
37	1.0D-1.0Wx	Yes			DL	1			OL2	1								
38	1.0D+1.0...	Yes			DL	1			OL3	1								
39	1.0D-1.0Wz	Yes			DL	1			OL4	1								
40	1.0D+1.0...	Yes			DL	1			OL5	1								
41	1.0D-1.0...	Yes			DL	1			OL6	1								

Design Strips

	Label	Rebar Angle from Pl...	No. of Design Cuts	Design Rule
1	DS1	0	50	Typical
2	DS2	90	50	Typical

Load Categories

	Category	Point Loads	Line Loads	Area Loads
1	DL	22		
2	RLL	28		
3	OL1	41		
4	OL2	42		
5	OL3	42		
6	OL4	42		
7	OL5	44		
8	OL6	45		



Company : Vector Structural Engineering
 Designer : STB
 Job Number : U2716.114.181
 Model Name : Ground Mount

Apr 6, 2021
 2:19 PM
 Checked By: JSP

Slab Overturning Safety Factors (By Combination) (Continued)

LC	Slab	Angle[deg]	Mo-xx[lb-ft]	Ms-xx[lb-ft]	Mo-zz[lb-ft]	Ms-zz[lb-ft]	Ms-xx/Mo-xx	Ms-zz/Mo-zz
52	7	S4	0	594.871	40972.06	0	10899.038	9.999+
53	7	S5	0	518.962	40971.986	0	10897.379	9.999+
54	7	S6	0	498.93	40940.089	0	10892.901	9.999+
55	7	S7	0	712.396	41125.254	0	10934.27	9.999+
56	7	S8	0	160.905	39972.711	0	10393.661	9.999+
57	8	S1	0	4667.612	40072.785	634.001	10300.791	8.585
58	8	S2	0	8852.809	40987.998	955.729	10531.668	4.63
59	8	S3	0	5289.285	40907.355	594.917	10493.216	7.734
60	8	S4	0	3718.247	40925.394	405.092	10499.656	9.999+
61	8	S5	0	3647.56	40925.556	403.159	10499.667	9.999+
62	8	S6	0	3636.323	40906.94	405.047	10493.191	9.999+
63	8	S7	0	3853.522	40985.491	402.598	10523.055	9.999+
64	8	S8	0	1931.158	40141.558	283.609	10318.884	9.999+
65	9	S1	0	7493.722	44163.661	1044.504	11538.615	5.893
66	9	S2	0	17890.283	49486.132	1913.728	12873.4	2.766
67	9	S3	0	16201.702	49062.242	1795.631	12661.955	3.028
68	9	S4	0	16584.102	49151.733	1814.196	12693.36	2.964
69	9	S5	0	16579.066	49152.935	1815.382	12693.465	2.965
70	9	S6	0	16225.419	49056.861	1793.44	12655.396	3.023
71	9	S7	0	17849.097	49474.954	1914.411	12869.914	2.772
72	9	S8	0	8112.09	44538.856	1111.445	11637.911	5.49
73	10	S1	0	8048.662	44163.661	932.746	11538.615	5.487
74	10	S2	0	18650.568	49486.132	1563.026	12873.4	2.653
75	10	S3	0	17080.484	49062.242	1518	12656.036	2.872
76	10	S4	0	17438.676	49151.733	1527.244	12693.36	2.819
77	10	S5	0	17432.837	49152.935	1529.252	12693.465	2.82
78	10	S6	0	17107.919	49056.861	1518.633	12655.396	2.867
79	10	S7	0	18604.472	49474.954	1563.027	12869.914	2.659
80	10	S8	0	8701.039	44538.856	990.048	11637.911	5.119
81	11	S1	0	841.717	43883.138	0	12779.118	9.999+
82	11	S2	0	3819.876	50734.543	0	15050.123	9.999+
83	11	S3	0	2744.623	49678.093	0	14791.414	9.999+
84	11	S4	0	3020.864	49856.641	0	14842.23	9.999+
85	11	S5	0	3014.366	49856.262	0	14846.168	9.999+
86	11	S6	0	2774.92	49681.111	0	14781.265	9.999+
87	11	S7	0	3779.486	50718.341	0	15138.244	9.999+
88	11	S8	0	967.405	44283.582	0	12052.947	9.999+
89	12	S1	0	0	44437.291	0	12567.579	9.999+
90	12	S2	0	0	50893.383	0	14784.251	9.999+
91	12	S3	0	0	50299.871	0	14504.59	9.999+
92	12	S4	0	0	50320.807	0	14556.761	9.999+
93	12	S5	0	0	50324.525	0	14560.636	9.999+
94	12	S6	0	0	50283.473	0	14490.478	9.999+
95	12	S7	0	0	50900.91	0	14881.51	9.999+
96	12	S8	0	0	44845.859	0	11912.91	9.999+
97	13	S1	0	357.983	43883.138	0	12007.637	9.999+
98	13	S2	0	1307.138	50734.543	0	13545.503	9.999+
99	13	S3	0	597.786	49678.093	0	13190.613	9.999+
100	13	S4	0	446.153	49856.641	0	12992.897	9.999+
101	13	S5	0	389.222	49856.262	0	12991.749	9.999+
102	13	S6	0	374.197	49681.111	0	12955.178	9.999+
103	13	S7	0	534.297	50718.341	0	13172.407	9.999+
104	13	S8	0	120.679	44283.582	0	11264.879	9.999+
105	14	S1	0	3500.709	44163.661	475.501	11538.615	9.999+
106	14	S2	0	6639.607	49486.132	716.797	12873.4	7.453
107	14	S3	0	3966.963	49062.242	446.187	12661.955	9.999+
108	14	S4	0	2788.685	49151.733	303.819	12693.36	9.999+



Slab Overturning Safety Factors (By Combination) (Continued)

LC	Slab	Angle[deg]	Mo-xx[lb-ft]	Ms-xx[lb-ft]	Mo-zz[lb-ft]	Ms-zz[lb-ft]	Ms-xx/Mo-xx	Ms-zz/Mo-zz	
109	14	S5	0	2735.67	49152.935	302.369	12693.465	9.999+	9.999+
110	14	S6	0	2727.242	49056.861	303.785	12661.99	9.999+	9.999+
111	14	S7	0	2890.141	49474.954	301.949	12820.631	9.999+	9.999+
112	14	S8	0	1448.368	44538.856	212.707	11637.911	9.999+	9.999+
113	15	S1	0	9991.63	36065.507	1392.672	9270.712	3.61	6.657
114	15	S2	0	23853.71	36889.198	2551.638	9478.501	1.546	3.715
115	15	S3	0	21602.27	36816.619	2394.175	9443.894	1.704	3.945
116	15	S4	0	22112.136	36832.855	2418.928	9449.69	1.666	3.907
117	15	S5	0	22105.421	36833	2420.51	9449.7	1.666	3.904
118	15	S6	0	21633.892	36816.246	2391.253	9443.872	1.702	3.949
119	15	S7	0	23798.796	36886.942	2552.547	9477.851	1.55	3.713
120	15	S8	0	10816.119	36127.402	1481.926	9286.996	3.34	6.267
121	16	S1	0	10731.549	36065.507	1243.662	9270.712	3.361	7.454
122	16	S2	0	24867.424	36889.198	2084.035	9478.501	1.483	4.548
123	16	S3	0	22773.978	36816.619	2024	9443.894	1.617	4.666
124	16	S4	0	23251.568	36832.855	2036.325	9449.69	1.584	4.641
125	16	S5	0	23243.783	36833	2039.003	9449.7	1.585	4.634
126	16	S6	0	22810.559	36816.246	2024.844	9443.872	1.614	4.664
127	16	S7	0	24805.963	36886.942	2084.035	9477.851	1.487	4.548
128	16	S8	0	11601.385	36127.402	1320.064	9286.996	3.114	7.035
129	17	S1	0	1122.289	35909.738	0	10924.716	9.999+	9.999+
130	17	S2	0	5093.168	37014.992	0	12439.202	7.268	9.999+
131	17	S3	0	3659.498	36845.882	0	12283.174	9.999+	9.999+
132	17	S4	0	4027.818	36874.854	0	12314.851	9.155	9.999+
133	17	S5	0	4019.155	36874.787	0	12319.97	9.175	9.999+
134	17	S6	0	3699.893	36846.08	0	12278.364	9.959	9.999+
135	17	S7	0	5039.314	37012.729	0	12502.292	7.345	9.999+
136	17	S8	0	1289.874	35975.44	0	10422.098	9.999+	9.999+
137	18	S1	0	0	36648.608	0	10642.663	9.999+	9.999+
138	18	S2	0	0	37226.779	0	12084.706	9.999+	9.999+
139	18	S3	0	0	37674.92	0	11900.742	9.999+	9.999+
140	18	S4	0	0	37493.743	0	11934.226	9.999+	9.999+
141	18	S5	0	0	37499.138	0	11939.262	9.999+	9.999+
142	18	S6	0	0	37649.23	0	11890.648	9.999+	9.999+
143	18	S7	0	0	37256.155	0	12159.98	9.999+	9.999+
144	18	S8	0	0	36725.141	0	10235.382	9.999+	9.999+
145	19	S1	0	477.31	35909.738	0	9896.075	9.999+	9.999+
146	19	S2	0	1742.851	37014.992	0	10433.043	9.999+	9.999+
147	19	S3	0	797.049	36845.882	0	10148.771	9.999+	9.999+
148	19	S4	0	594.871	36874.854	0	9849.073	9.999+	9.999+
149	19	S5	0	518.962	36874.787	0	9847.412	9.999+	9.999+
150	19	S6	0	498.93	36846.08	0	9843.582	9.999+	9.999+
151	19	S7	0	712.396	37012.729	0	9881.176	9.999+	9.999+
152	19	S8	0	160.905	35975.44	0	9371.341	9.999+	9.999+
153	20	S1	0	4667.612	36065.507	634.001	9270.712	7.727	9.999+
154	20	S2	0	8852.809	36889.198	955.729	9478.501	4.167	9.918
155	20	S3	0	5289.285	36816.619	594.917	9443.894	6.961	9.999+
156	20	S4	0	3718.247	36832.855	405.092	9449.69	9.906	9.999+
157	20	S5	0	3647.56	36833	403.159	9449.7	9.999+	9.999+
158	20	S6	0	3636.323	36816.246	405.047	9443.872	9.999+	9.999+
159	20	S7	0	3853.522	36886.942	402.598	9470.75	9.572	9.999+
160	20	S8	0	1931.158	36127.402	283.609	9286.996	9.999+	9.999+



Company : Vector Structural Engineering
 Designer : STB
 Job Number : U2716.114.181
 Model Name : Ground Mount

Apr 6, 2021
 2:19 PM
 Checked By: JSP

Slab Sliding Safety Factors (By Combination)

	LC	Slab	Angle[deg]	Va-xx[lb]	Vr-xx[lb]	Va-zz[lb]	Vr-zz[lb]	SR-xx	SR-zz
1	1	S1	0	21.3	2460.688	0	2460.688	9.999+	9.999+
2	1	S2	0	1.788	2526.635	0	2526.635	9.999+	9.999+
3	1	S3	0	0	2518.372	0	2518.372	9.999+	9.999+
4	1	S4	0	0	2519.917	0	2519.917	9.999+	9.999+
5	1	S5	0	0	2519.92	0	2519.92	9.999+	9.999+
6	1	S6	0	0	2518.366	0	2518.366	9.999+	9.999+
7	1	S7	0	1.754	2526.48	0	2526.48	9.999+	9.999+
8	1	S8	0	21.263	2465.05	0	2465.05	9.999+	9.999+
9	2	S1	0	141.394	2791.941	0	2791.941	9.999+	9.999+
10	2	S2	0	13.992	3269.399	0	3269.399	9.999+	9.999+
11	2	S3	0	1.754	3211.421	0	3211.421	9.999+	9.999+
12	2	S4	0	0	3221.903	0	3221.903	9.999+	9.999+
13	2	S5	0	0	3221.935	0	3221.935	9.999+	9.999+
14	2	S6	0	1.954	3211.326	1.185	3211.326	9.999+	9.999+
15	2	S7	0	14.018	3268.327	1.404	3268.327	9.999+	9.999+
16	2	S8	0	141.32	2822.308	0	2822.308	9.999+	9.999+
17	3	S1	0	78.913	2180.562	549.253	2180.562	9.999+	3.97
18	3	S2	0	8.748	1919.931	1548.607	1919.931	9.999+	1.24
19	3	S3	0	1.177	1944.406	1306.394	1944.406	9.999+	1.488
20	3	S4	0	.61	1939.704	1359.702	1939.704	9.999+	1.427
21	3	S5	0	1.284	1939.691	1358.909	1939.691	9.999+	1.427
22	3	S6	0	0	1944.465	1309.841	1944.465	9.999+	1.485
23	3	S7	0	9.758	1920.085	1541.518	1920.085	9.999+	1.246
24	3	S8	0	79.386	2163.738	601.809	2163.738	9.999+	3.595
25	4	S1	0	72.308	2212.757	461.692	2212.757	9.999+	4.793
26	4	S2	0	2.748	2028.916	1307.577	2028.916	9.999+	1.552
27	4	S3	0	0	2032.612	1099.843	2032.612	9.999+	1.848
28	4	S4	0	0	2031.199	1145.96	2031.199	9.999+	1.772
29	4	S5	0	1.155	2031.183	1144.985	2031.183	9.999+	1.774
30	4	S6	0	.497	2032.672	1104.018	2032.672	9.999+	1.841
31	4	S7	0	3.164	2028.967	1299.683	2028.967	9.999+	1.561
32	4	S8	0	73.275	2199.285	506.864	2199.285	9.999+	4.339
33	5	S1	0	140.467	2793.298	651.276	2793.298	9.999+	4.289
34	5	S2	0	14.095	3245.587	1836.468	3245.587	9.999+	1.767
35	5	S3	0	1.35	3199.07	1549.114	3199.07	9.999+	2.065
36	5	S4	0	.71	3207.939	1612.372	3207.939	9.999+	1.99
37	5	S5	0	1.525	3207.961	1611.42	3207.961	9.999+	1.991
38	5	S6	0	.633	3198.986	1553.248	3198.986	9.999+	2.06
39	5	S7	0	15.23	3245.069	1827.991	3245.069	9.999+	1.775
40	5	S8	0	140.967	2822.783	713.629	2822.783	9.999+	3.956
41	6	S1	0	116.492	2738.553	565.773	2738.553	9.999+	4.84
42	6	S2	0	17.048	3162.102	1590.167	3162.102	9.999+	1.989
43	6	S3	0	2.297	3106.775	1344.215	3106.775	9.999+	2.311
44	6	S4	0	.954	3116.721	1398.005	3116.721	9.999+	2.229
45	6	S5	0	1.258	3116.736	1397.452	3116.736	9.999+	2.23
46	6	S6	0	2.072	3106.711	1346.67	3106.711	9.999+	2.307
47	6	S7	0	17.691	3161.585	1584.524	3161.585	9.999+	1.995
48	6	S8	0	116.42	2764.716	619.055	2764.716	9.999+	4.466
49	7	S1	0	63.452	2588.013	257.047	2588.013	9.999+	9.999+
50	7	S2	0	13.94	2764.025	609.227	2764.025	9.999+	4.537
51	7	S3	0	1.344	2688.268	378.947	2688.268	9.999+	7.094
52	7	S4	0	1.329	2616.487	230.877	2616.487	9.999+	9.999+
53	7	S5	0	1.187	2616.012	223.323	2616.012	9.999+	9.999+
54	7	S6	0	1.144	2614.914	219.098	2614.914	9.999+	9.999+
55	7	S7	0	1.791	2623.258	257.215	2623.258	9.999+	9.999+
56	7	S8	0	46.136	2519.392	99.774	2519.392	9.999+	9.999+
57	8	S1	0	22.043	2331.933	259.915	2331.933	9.999+	8.972



Company : Vector Structural Engineering
 Designer : STB
 Job Number : U2716.114.181
 Model Name : Ground Mount

Apr 6, 2021
 2:19 PM
 Checked By: JSP

Slab Sliding Safety Factors (By Combination) (Continued)

	LC	Slab	Angle[deg]	Va-xx[lb]	Vr-xx[lb]	Va-zz[lb]	Vr-zz[lb]	SR-xx	SR-zz
58	8	S2	0	12.337	2304.887	573.173	2304.887	9.999+	4.021
59	8	S3	0	.344	2375.778	315.707	2375.778	9.999+	7.525
60	8	S4	0	1.351	2423.425	229.812	2423.425	9.999+	9.999+
61	8	S5	0	1.231	2423.827	223.868	2423.827	9.999+	9.999+
62	8	S6	0	1.18	2421.792	218.992	2421.792	9.999+	9.999+
63	8	S7	0	1.76	2429.86	257.238	2429.86	9.999+	9.446
64	8	S8	0	3.878	2410.56	99.771	2410.56	9.999+	9.999+
65	9	S1	0	36.21	2499.033	411.94	2499.033	9.999+	6.066
66	9	S2	0	3.039	2628.68	1161.455	2628.68	9.999+	2.263
67	9	S3	0	.432	2607.684	979.795	2607.684	9.999+	2.661
68	9	S4	0	.458	2611.247	1019.776	2611.247	9.999+	2.561
69	9	S5	0	.963	2611.26	1019.182	2611.26	9.999+	2.562
70	9	S6	0	1.465	2607.661	983.269	2607.661	9.999+	2.652
71	9	S7	0	2.318	2628.069	1155.085	2628.069	9.999+	2.275
72	9	S8	0	35.819	2507.01	451.357	2507.01	9.999+	5.554
73	10	S1	0	41.164	2523.18	346.269	2523.18	9.999+	7.287
74	10	S2	0	7.539	2710.419	980.683	2710.419	9.999+	2.764
75	10	S3	0	1.315	2673.839	824.882	2673.839	9.999+	3.241
76	10	S4	0	0	2679.868	859.47	2679.868	9.999+	3.118
77	10	S5	0	.866	2679.879	858.739	2679.879	9.999+	3.121
78	10	S6	0	1.838	2673.816	828.902	2673.816	9.999+	3.226
79	10	S7	0	7.263	2709.731	973.709	2709.731	9.999+	2.783
80	10	S8	0	40.403	2533.67	380.148	2533.67	9.999+	6.665
81	11	S1	0	200.746	2958.586	488.457	2958.586	9.999+	6.057
82	11	S2	0	20.171	3622.922	1377.351	3622.922	9.999+	2.63
83	11	S3	0	2.328	3548.683	1161.836	3548.683	9.999+	3.054
84	11	S4	0	.532	3562.423	1209.279	3562.423	9.999+	2.946
85	11	S5	0	1.144	3562.463	1208.565	3562.463	9.999+	2.948
86	11	S6	0	1.94	3548.551	1164.047	3548.551	9.999+	3.048
87	11	S7	0	21.059	3621.807	1372.047	3621.807	9.999+	2.64
88	11	S8	0	201.084	3001.293	535.222	3001.293	9.999+	5.608
89	12	S1	0	182.764	2917.526	424.33	2917.526	9.999+	6.876
90	12	S2	0	22.386	3560.309	1192.625	3560.309	9.999+	2.985
91	12	S3	0	3.038	3479.461	1008.161	3479.461	9.999+	3.451
92	12	S4	0	.716	3494.009	1048.504	3494.009	9.999+	3.332
93	12	S5	0	.943	3494.043	1048.089	3494.043	9.999+	3.334
94	12	S6	0	3.019	3479.345	1009.114	3479.345	9.999+	3.448
95	12	S7	0	22.905	3559.194	1189.446	3559.194	9.999+	2.992
96	12	S8	0	182.674	2957.742	464.291	2957.742	9.999+	6.37
97	13	S1	0	142.984	2804.621	192.786	2804.621	9.999+	9.999+
98	13	S2	0	20.055	3261.75	456.92	3261.75	9.999+	7.139
99	13	S3	0	.307	3165.581	284.21	3165.581	9.999+	9.999+
100	13	S4	0	.997	3118.833	173.158	3118.833	9.999+	9.999+
101	13	S5	0	.89	3118.5	167.493	3118.5	9.999+	9.999+
102	13	S6	0	2.323	3110.497	163.435	3110.497	9.999+	9.999+
103	13	S7	0	10.98	3155.448	193.965	3155.448	9.999+	9.999+
104	13	S8	0	129.961	2773.75	74.831	2773.75	9.999+	9.999+
105	14	S1	0	78.864	2612.561	194.936	2612.561	9.999+	9.999+
106	14	S2	0	.347	2917.397	429.88	2917.397	9.999+	6.787
107	14	S3	0	1.057	2931.213	236.78	2931.213	9.999+	9.999+
108	14	S4	0	1.013	2974.037	172.359	2974.037	9.999+	9.999+
109	14	S5	0	.923	2974.361	167.901	2974.361	9.999+	9.999+
110	14	S6	0	.58	2965.656	165.132	2965.656	9.999+	9.999+
111	14	S7	0	10.957	3010.4	191.875	3010.4	9.999+	9.999+
112	14	S8	0	92.45	2692.126	74.828	2692.126	9.999+	9.999+
113	15	S1	0	81.043	1934.493	549.253	1934.493	9.999+	3.522
114	15	S2	0	8.926	1667.268	1548.607	1667.268	9.999+	1.077



Company : Vector Structural Engineering
Designer : STB
Job Number : U2716.114.181
Model Name : Ground Mount

Apr 6, 2021
2:19 PM
Checked By: JSP

Envelope Slab Soil Pressures (Continued)

	Label	UC	LC	Soil Pressure[psf]	Allowable Bearing[psf]	Point
8	S8	.35	5	524.446	1500	N275



Company:		Date:	5/14/2018
Engineer:		Page:	1/6
Project:			
Address:			
Phone:			
E-mail:			

1. Project information

Customer company:
Customer contact name:
Customer e-mail:
Comment:

Project description:
Location:
Fastening description:

2. Input Data & Anchor Parameters

General

Design method: ACI 318-14
Units: Imperial units

Anchor Information:

Anchor type: Bonded anchor
Material: F1554 Grade 36
Diameter (inch): 0.375
Effective Embedment depth, h_{ef} (inch): 6.000
Code report: ICC-ES ESR-4057
Anchor category: -
Anchor ductility: Yes
 h_{min} (inch): 7.25
 c_{ac} (inch): 10.99
 c_{min} (inch): 1.75
 s_{min} (inch): 3.00

Base Material

Concrete: Normal-weight
Concrete thickness, h (inch): 30.00
State: Cracked
Compressive strength, f'_c (psi): 2500
 $\Psi_{c,v}$: 1.0
Reinforcement condition: B tension, B shear
Supplemental reinforcement: Not applicable
Reinforcement provided at corners: No
Ignore concrete breakout in tension: No
Ignore concrete breakout in shear: No
Hole condition: Dry concrete
Inspection: Periodic
Temperature range, Short/Long: 150/110°F
Ignore 6do requirement: Not applicable
Build-up grout pad: No

Base Plate

Length x Width x Thickness (inch): 4.75 x 4.75 x 0.31

Recommended Anchor

Anchor Name: SET-3G - SET-3G w/ 3/8"Ø F1554 Gr. 36
Code Report: ICC-ES ESR-4057





Company:		Date:	5/14/2018
Engineer:		Page:	2/6
Project:			
Address:			
Phone:			
E-mail:			

Load and Geometry

Load factor source: ACI 318 Section 5.3

Load combination: not set

Seismic design: No

Anchors subjected to sustained tension: No

Apply entire shear load at front row: No

Anchors only resisting wind and/or seismic loads: No

Strength level loads:

N_{ua} [lb]: 4505

V_{uax} [lb]: 175

V_{uay} [lb]: -3179

M_{ux} [ft-lb]: 0

M_{uy} [ft-lb]: 0

M_{uz} [ft-lb]: 0

<Figure 1>

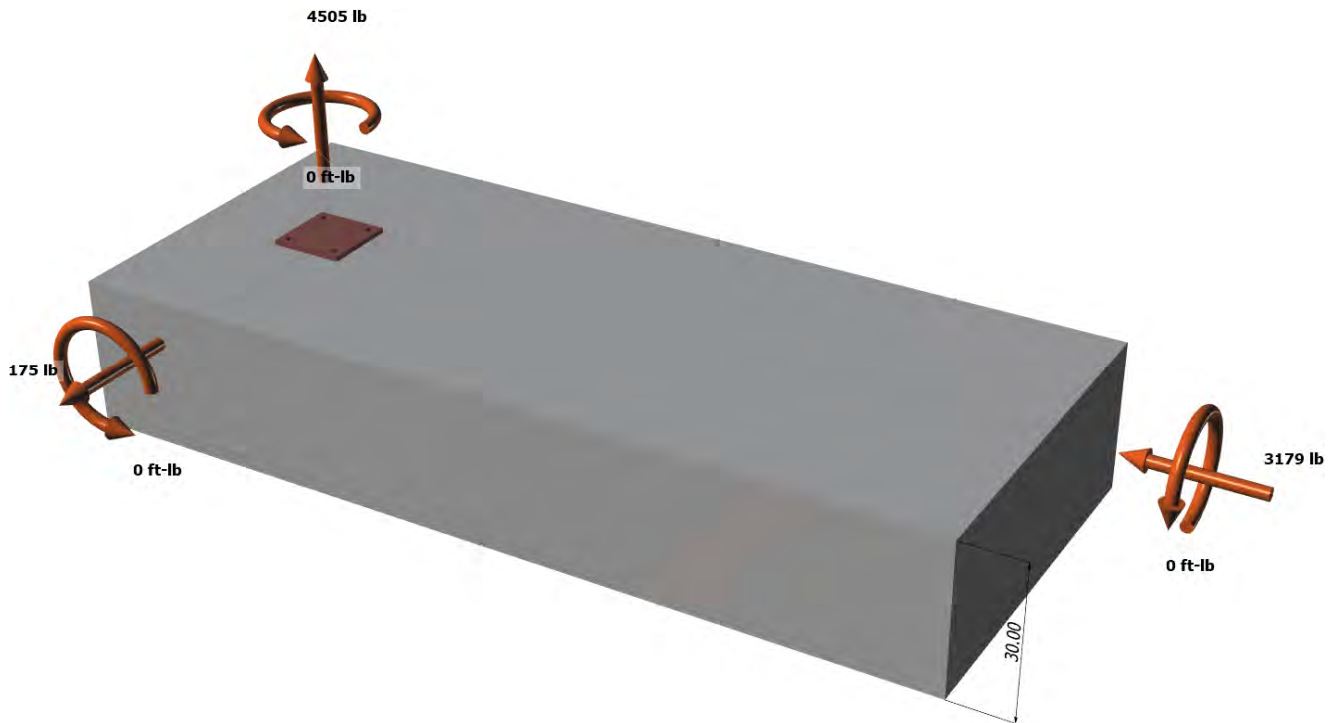



Company:		Date:	5/14/2018
Engineer:		Page:	3/6
Project:			
Address:			
Phone:			
E-mail:			

<Figure 2>





Company:		Date:	5/14/2018
Engineer:		Page:	4/6
Project:			
Address:			
Phone:			
E-mail:			

3. Resulting Anchor Forces

Anchor	Tension load, N _{ua} (lb)	Shear load x, V _{uax} (lb)	Shear load y, V _{uay} (lb)	Shear load combined, $\sqrt{(V_{uax})^2 + (V_{uay})^2}$ (lb)
1	1126.3	43.8	-794.8	796.0
2	1126.3	43.8	-794.8	796.0
3	1126.3	43.8	-794.8	796.0
4	1126.3	43.8	-794.8	796.0
Sum	4505.0	175.0	-3179.0	3183.8

Maximum concrete compression strain (%): 0.00
 Maximum concrete compression stress (psi): 0
 Resultant tension force (lb): 4505
 Resultant compression force (lb): 0
 Eccentricity of resultant tension forces in x-axis, e'_{Nx} (inch): 0.00
 Eccentricity of resultant tension forces in y-axis, e'_{Ny} (inch): 0.00
 Eccentricity of resultant shear forces in x-axis, e'_{Vx} (inch): 0.00
 Eccentricity of resultant shear forces in y-axis, e'_{Vy} (inch): 0.00

<Figure 3>

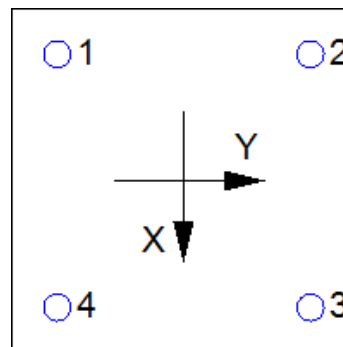

4. Steel Strength of Anchor in Tension (Sec. 17.4.1)

N _{sa} (lb)	φ	φN _{sa} (lb)
4525	0.75	3394

5. Concrete Breakout Strength of Anchor in Tension (Sec. 17.4.2)

$$N_b = K_c \lambda_a \sqrt{f_c} c h_{ef}^{1.5} \text{ (Eq. 17.4.2.2a)}$$

K _c	λ _a	f _c (psi)	h _{ef} (in)	N _b (lb)
17.0	1.00	2500	6.000	12492

$$\phi N_{cbg} = \phi (A_{Nc} / A_{Nco}) \psi_{ec,N} \psi_{ed,N} \psi_{c,N} \psi_{cp,N} N_b \text{ (Sec. 17.3.1 \& Eq. 17.4.2.1b)}$$

A _{Nc} (in ²)	A _{Nco} (in ²)	c _{a,min} (in)	ψ _{ec,N}	ψ _{ed,N}	ψ _{c,N}	ψ _{cp,N}	N _b (lb)	φ	φN _{cbg} (lb)
424.63	324.00	7.25	1.000	0.942	1.00	1.000	12492	0.65	10021

6. Adhesive Strength of Anchor in Tension (Sec. 17.4.5)

$$\tau_{k,cr} = \tau_{k,cr,short-term} K_{sat} (f_c / 2,500)^n$$

τ _{k,cr} (psi)	f _{short-term}	K _{sat}	f _c (psi)	n	τ _{k,cr} (psi)
1346	1.00	1.00	2500	0.24	1346

$$N_{ba} = \lambda_a \tau_{cr} \pi d_a h_{ef} \text{ (Eq. 17.4.5.2)}$$

λ _a	τ _{cr} (psi)	d _a (in)	h _{ef} (in)	N _{ba} (lb)
1.00	1346	0.38	6.000	9514

$$\phi N_{ag} = \phi (A_{Na} / A_{Na0}) \psi_{ec,Na} \psi_{ed,Na} \psi_{cp,Na} N_{ba} \text{ (Sec. 17.3.1 \& Eq. 17.4.5.1b)}$$

A _{Na} (in ²)	A _{Na0} (in ²)	c _{Na} (in)	c _{a,min} (in)	ψ _{ec,Na}	ψ _{ed,Na}	ψ _{cp,Na}	N _{ba} (lb)	φ	φN _{ag} (lb)
198.45	112.09	5.29	7.25	1.000	1.000	1.000	9514	0.55	9265



Company:		Date:	5/14/2018
Engineer:		Page:	5/6
Project:			
Address:			
Phone:			
E-mail:			

8. Steel Strength of Anchor in Shear (Sec. 17.5.1)

V_{sa} (lb)	ϕ_{grout}	ϕ	$\phi_{grout}\phi V_{sa}$ (lb)
2715	1.0	0.65	1765

9. Concrete Breakout Strength of Anchor in Shear (Sec. 17.5.2)

Shear perpendicular to edge in x-direction:

$V_{bx} = \min|7(l_e / d_a)^{0.2} \sqrt{d_a} \lambda_a \sqrt{f_c} c_{a1}^{1.5}; 9 \lambda_a \sqrt{f_c} c_{a1}^{1.5}|$ (Eq. 17.5.2.2a & Eq. 17.5.2.2b)

l_e (in)	d_a (in)	λ_a	f_c (psi)	c_{a1} (in)	V_{bx} (lb)
3.00	0.375	1.00	2500	13.75	16564

$\phi V_{cbgx} = \phi (A_{Vc} / A_{Vco}) \Psi_{ec,V} \Psi_{ed,V} \Psi_{c,V} \Psi_{h,V} V_{bx}$ (Sec. 17.3.1 & Eq. 17.5.2.1b)

A_{Vc} (in ²)	A_{Vco} (in ²)	$\Psi_{ec,V}$	$\Psi_{ed,V}$	$\Psi_{c,V}$	$\Psi_{h,V}$	V_{bx} (lb)	ϕ	ϕV_{cbgx} (lb)
647.11	850.78	1.000	0.805	1.000	1.000	16564	0.70	7103

Shear perpendicular to edge in y-direction:

$V_{by} = \min|7(l_e / d_a)^{0.2} \sqrt{d_a} \lambda_a \sqrt{f_c} c_{a1}^{1.5}; 9 \lambda_a \sqrt{f_c} c_{a1}^{1.5}|$ (Eq. 17.5.2.2a & Eq. 17.5.2.2b)

l_e (in)	d_a (in)	λ_a	f_c (psi)	c_{a1} (in)	V_{by} (lb)
3.00	0.375	1.00	2500	10.75	11450

$\phi V_{cbgy} = \phi (A_{Vc} / A_{Vco}) \Psi_{ec,V} \Psi_{ed,V} \Psi_{c,V} \Psi_{h,V} V_{by}$ (Sec. 17.3.1 & Eq. 17.5.2.1b)

A_{Vc} (in ²)	A_{Vco} (in ²)	$\Psi_{ec,V}$	$\Psi_{ed,V}$	$\Psi_{c,V}$	$\Psi_{h,V}$	V_{by} (lb)	ϕ	ϕV_{cbgy} (lb)
387.00	520.03	1.000	0.891	1.000	1.000	11450	0.70	5313

Shear parallel to edge in x-direction:

$V_{by} = \min|7(l_e / d_a)^{0.2} \sqrt{d_a} \lambda_a \sqrt{f_c} c_{a1}^{1.5}; 9 \lambda_a \sqrt{f_c} c_{a1}^{1.5}|$ (Eq. 17.5.2.2a & Eq. 17.5.2.2b)

l_e (in)	d_a (in)	λ_a	f_c (psi)	c_{a1} (in)	V_{by} (lb)
3.00	0.375	1.00	2500	7.25	6342

$\phi V_{cbgx} = \phi (2)(A_{Vc} / A_{Vco}) \Psi_{ec,V} \Psi_{ed,V} \Psi_{c,V} \Psi_{h,V} V_{by}$ (Sec. 17.3.1, 17.5.2.1(c) & Eq. 17.5.2.1b)

A_{Vc} (in ²)	A_{Vco} (in ²)	$\Psi_{ec,V}$	$\Psi_{ed,V}$	$\Psi_{c,V}$	$\Psi_{h,V}$	V_{by} (lb)	ϕ	ϕV_{cbgx} (lb)
261.00	236.53	1.000	1.000	1.000	1.000	6342	0.70	9797

Shear parallel to edge in y-direction:

$V_{bx} = \min|7(l_e / d_a)^{0.2} \sqrt{d_a} \lambda_a \sqrt{f_c} c_{a1}^{1.5}; 9 \lambda_a \sqrt{f_c} c_{a1}^{1.5}|$ (Eq. 17.5.2.2a & Eq. 17.5.2.2b)

l_e (in)	d_a (in)	λ_a	f_c (psi)	c_{a1} (in)	V_{bx} (lb)
3.00	0.375	1.00	2500	10.25	10661

$\phi V_{cbgy} = \phi (2)(A_{Vc} / A_{Vco}) \Psi_{ec,V} \Psi_{ed,V} \Psi_{c,V} \Psi_{h,V} V_{bx}$ (Sec. 17.3.1, 17.5.2.1(c) & Eq. 17.5.2.1b)

A_{Vc} (in ²)	A_{Vco} (in ²)	$\Psi_{ec,V}$	$\Psi_{ed,V}$	$\Psi_{c,V}$	$\Psi_{h,V}$	V_{bx} (lb)	ϕ	ϕV_{cbgy} (lb)
401.67	472.78	1.000	1.000	1.000	1.000	10661	0.70	12680

10. Concrete Pryout Strength of Anchor in Shear (Sec. 17.5.3)

$\phi V_{cp} = \phi \min|k_{cp} N_{ag}; k_{cp} N_{cbg}| = \phi \min|k_{cp} (A_{Na} / A_{Na0}) \Psi_{ec,Na} \Psi_{ed,Na} \Psi_{cp,Na} N_{ba}; k_{cp} (A_{Nc} / A_{Nco}) \Psi_{ec,N} \Psi_{ed,N} \Psi_{cp,N} N_{b}|$ (Sec. 17.3.1 & Eq. 17.5.3.1b)

k_{cp}	A_{Na} (in ²)	A_{Na0} (in ²)	$\Psi_{ed,Na}$	$\Psi_{ec,Na}$	$\Psi_{cp,Na}$	N_{ba} (lb)	N_a (lb)
2.0	198.45	112.09	1.000	1.000	1.000	9514	16845

A_{Nc} (in ²)	A_{Nco} (in ²)	$\Psi_{ec,N}$	$\Psi_{ed,N}$	$\Psi_{c,N}$	$\Psi_{cp,N}$	N_b (lb)	N_{cb} (lb)	ϕ
424.63	324.00	1.000	0.942	1.000	1.000	12492	15417	0.70

Input data and results must be checked for agreement with the existing circumstances, the standards and guidelines must be checked for plausibility.



Company:		Date:	5/14/2018
Engineer:		Page:	6/6
Project:			
Address:			
Phone:			
E-mail:			

ϕV_{cpq} (lb)
21584

11. Results

Interaction of Tensile and Shear Forces (Sec. R17.6)

Tension	Factored Load, N_{ua} (lb)	Design Strength, ϕN_n (lb)	Ratio	Status	
Steel	1126	3394	0.33	Pass	
Concrete breakout	4505	10021	0.45	Pass	
Adhesive	4505	9265	0.49	Pass (Governs)	
Shear	Factored Load, V_{ua} (lb)	Design Strength, ϕV_n (lb)	Ratio	Status	
Steel	796	1765	0.45	Pass	
T Concrete breakout x+	175	7103	0.02	Pass	
T Concrete breakout y-	3179	5313	0.60	Pass	
Concrete breakout y-	88	9797	0.01	Pass	
Concrete breakout x-	1590	12680	0.13	Pass	
Concrete breakout, combined	-	-	0.60	Pass (Governs)	
Pryout	3184	21584	0.15	Pass	
Interaction check	$(N_{ua}/\phi N_{ua})^{5/3}$	$(V_{ua}/\phi V_{ua})^{5/3}$	Combined Ratio	Permissible	Status
Sec. R17.6	0.30	0.43	72.6%	1.0	Pass

SET-3G w/ 3/8"Ø F1554 Gr. 36 with hef = 6.000 inch meets the selected design criteria.

12. Warnings

- Designer must exercise own judgement to determine if this design is suitable.
- Refer to manufacturer's product literature for hole cleaning and installation instructions.



JOB NO.: U2716-070-181

DESIGNED: STB

PROJECT: Ground Mount Package for Ontario Canada

Framing Analysis

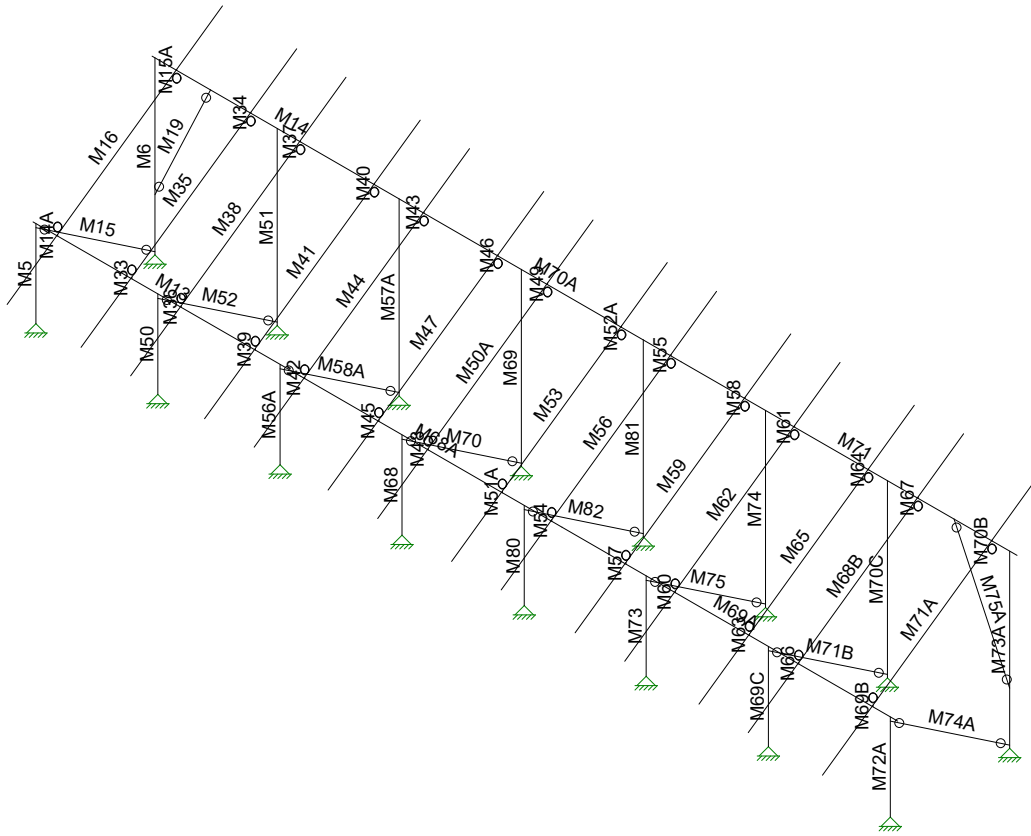

Vector Structural Engineeri...

STB

U2716.114.191

Ground Mount

SK - 3

Apr 6, 2021 at 2:12 PM

Sunmodo Sunturf A5 v3 85x45.r3d

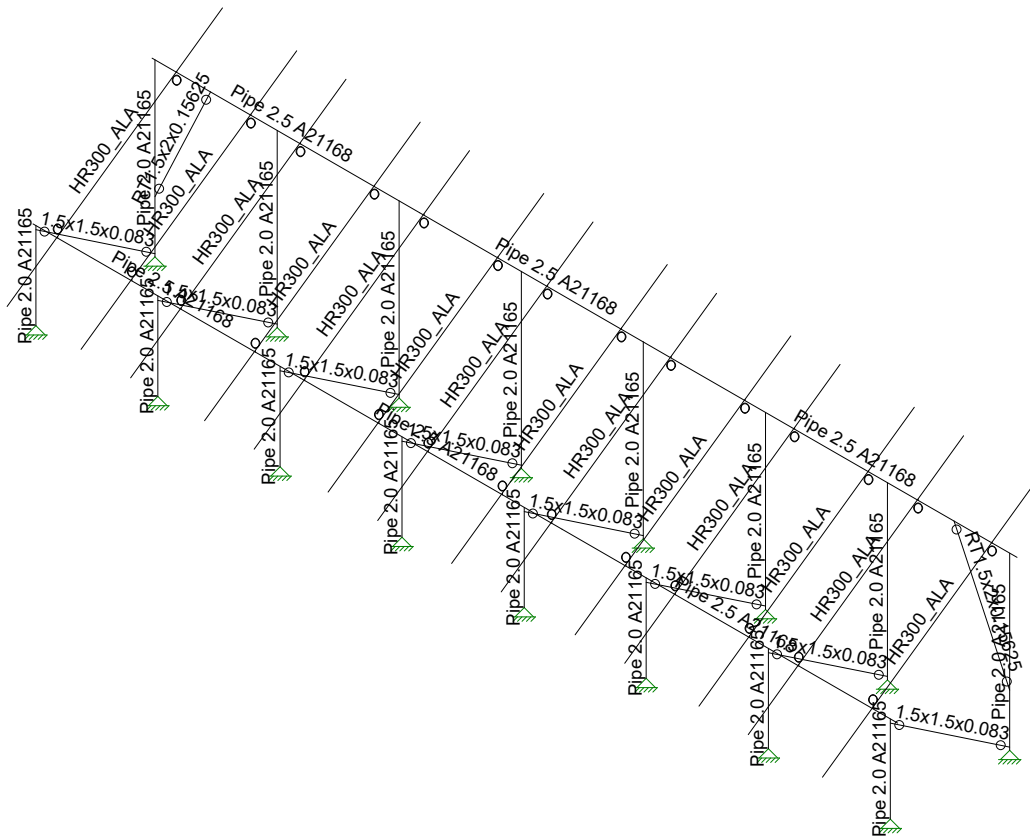

Vector Structural Engineeri...

STB

U2716.114.191

Ground Mount

SK - 4

Apr 6, 2021 at 2:12 PM

Sunmodo Sunturf A5 v3 85x45.r3d

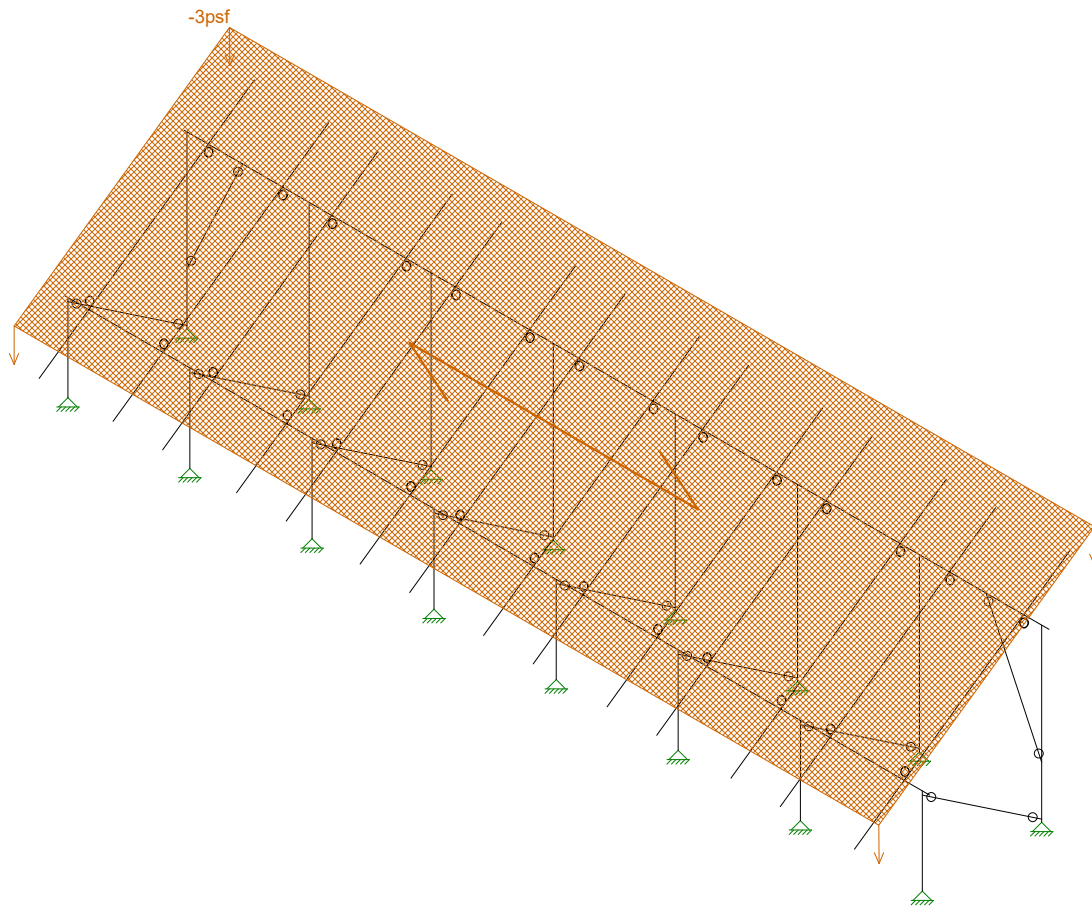

Loads: BLC 2, Solar Panel Weight

Vector Structural Engineeri...
STB
U2716.114.191

Ground Mount

SK - 5

Apr 6, 2021 at 2:12 PM

Sunmodo Sunturf A5 v3 85x45.r3d

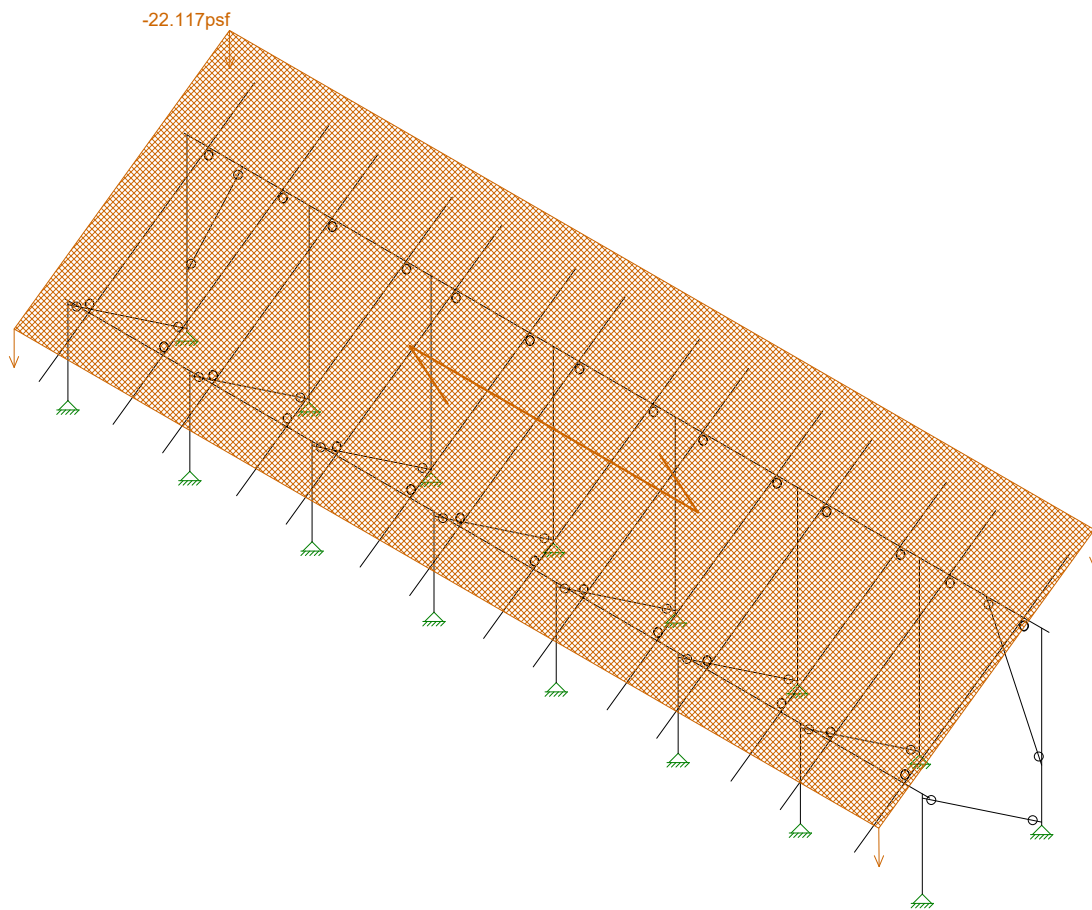

Loads: BLC 3, Roof Live/Snow

Vector Structural Engineeri...	Ground Mount	SK - 6
STB		Apr 6, 2021 at 2:12 PM
U2716.114.191		Sunmodo Sunturf A5 v3 85x45.r3d

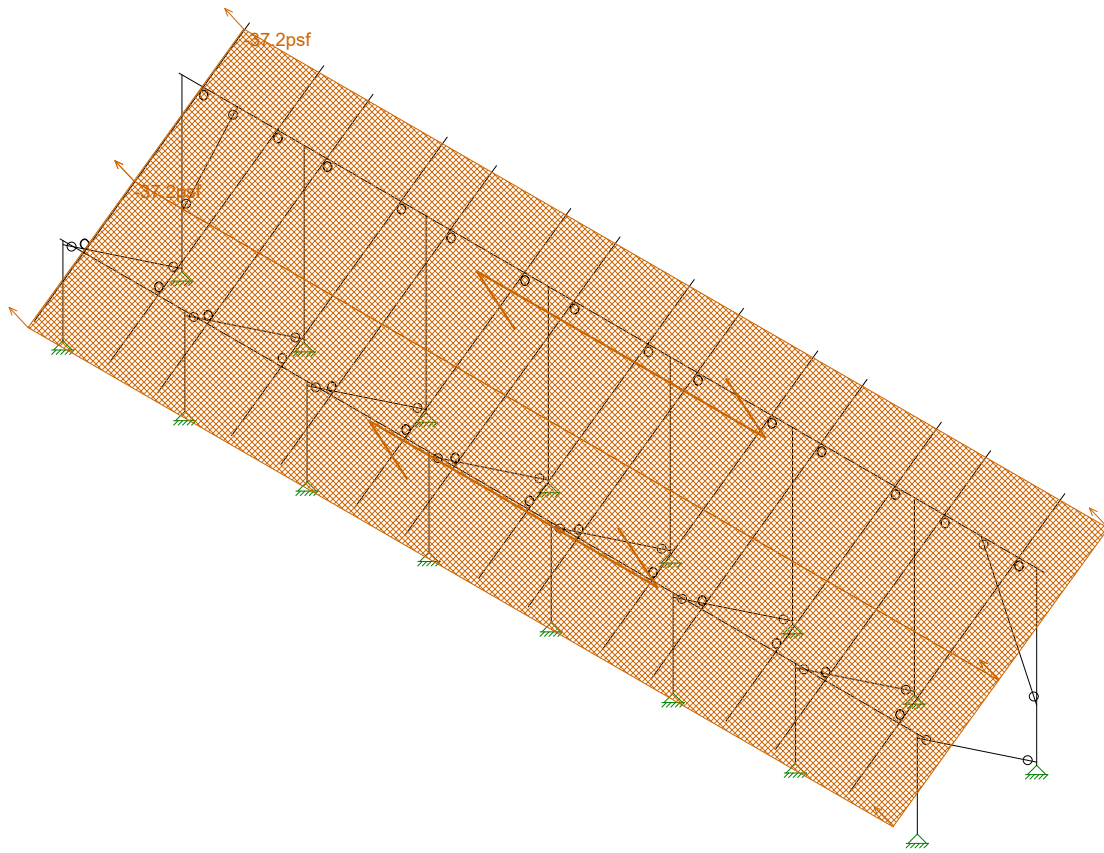

Loads: BLC 4, Wind A 0 deg

Vector Structural Engineeri...
STB
U2716.114.191

Ground Mount

SK - 7

Apr 6, 2021 at 2:13 PM

Sunmodo Sunturf A5 v3 85x45.r3d

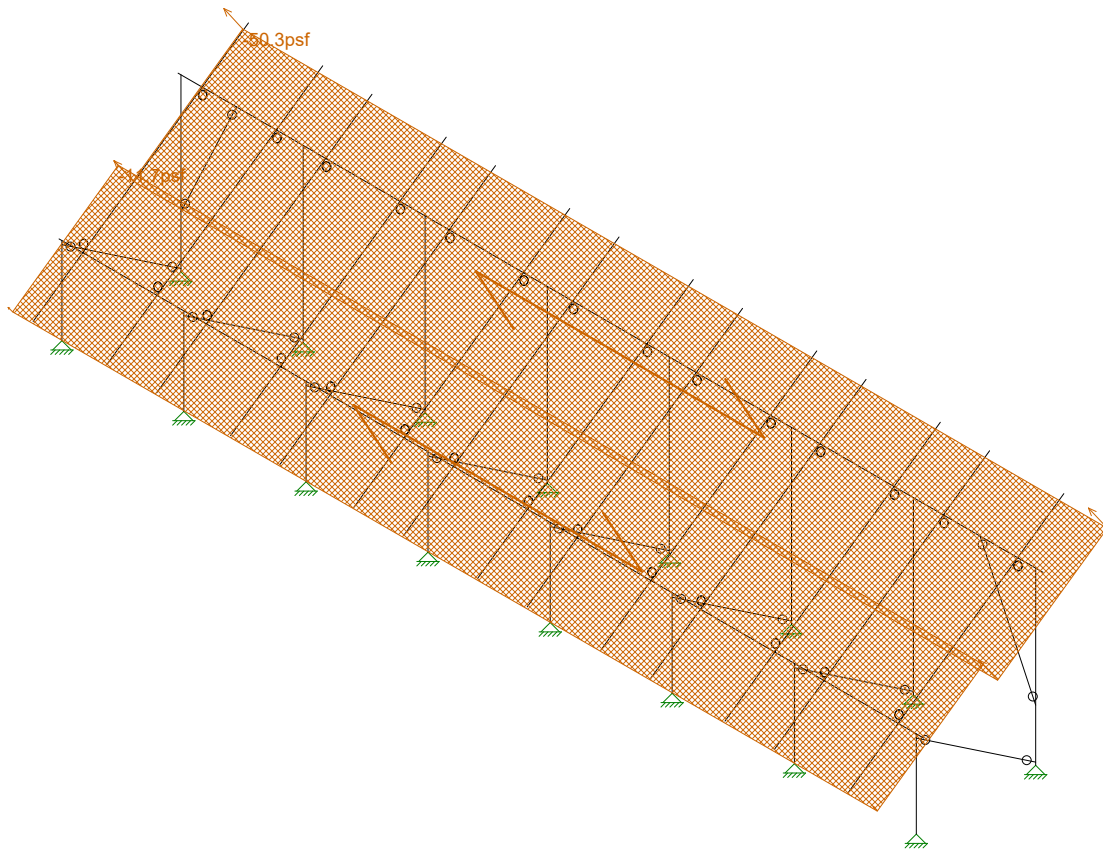

Loads: BLC 5, Wind B 0 deg

Vector Structural Engineeri..	Ground Mount	SK - 8
STB		Apr 6, 2021 at 2:13 PM
U2716.114.191		Sunmodo Sunturf A5 v3 85x45.r3d

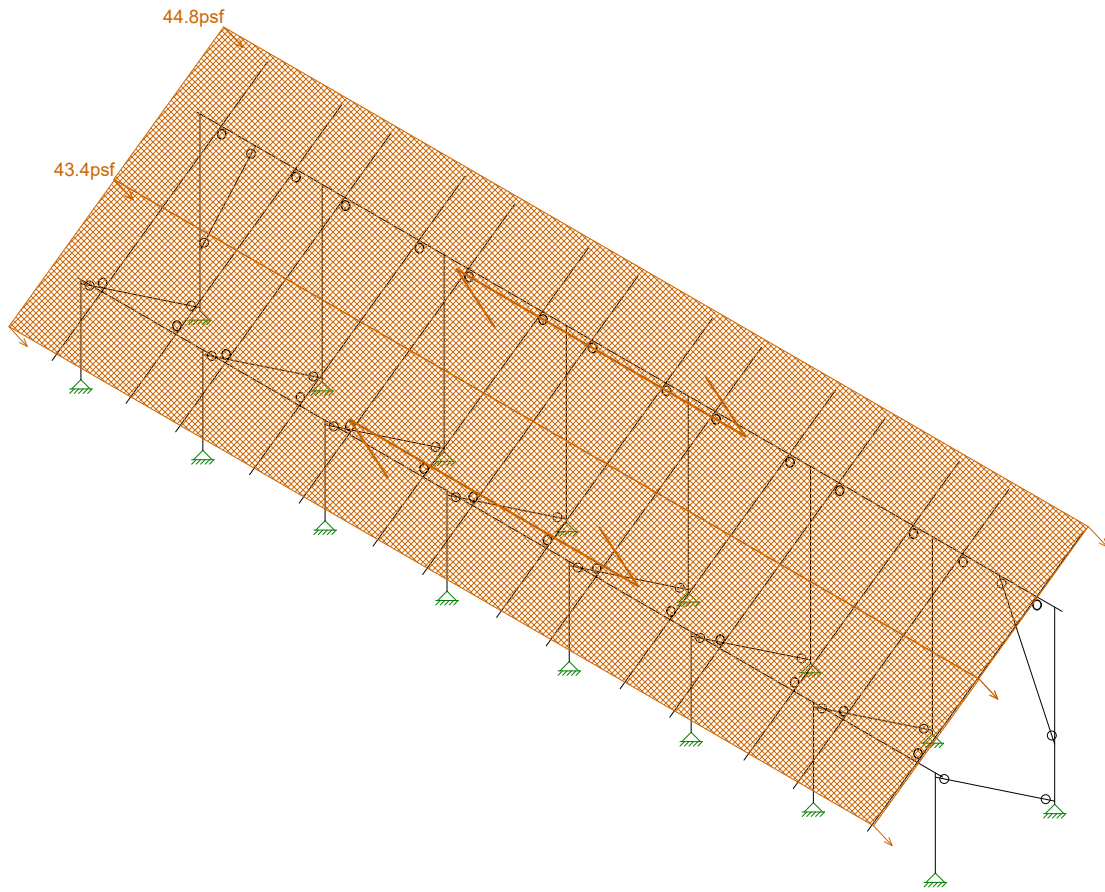

Loads: BLC 6, Wind A 180 deg

Vector Structural Engineeri...
STB
U2716.114.191

Ground Mount

SK - 9

Apr 6, 2021 at 2:13 PM

Sunmodo Sunturf A5 v3 85x45.r3d

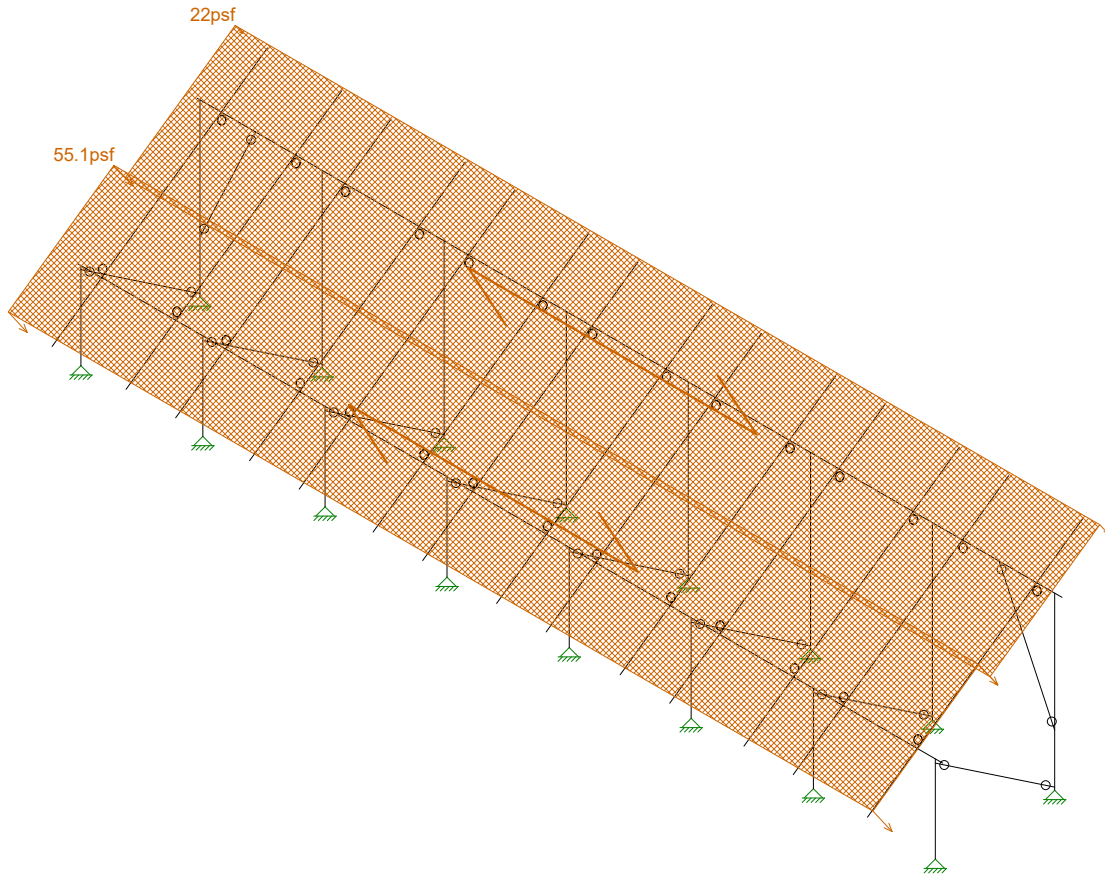

Loads: BLC 7, Wind B 180 deg

Vector Structural Engineeri...
STB
U2716.114.191

Ground Mount

SK - 10

Apr 6, 2021 at 2:13 PM

Sunmodo Sunturf A5 v3 85x45.r3d

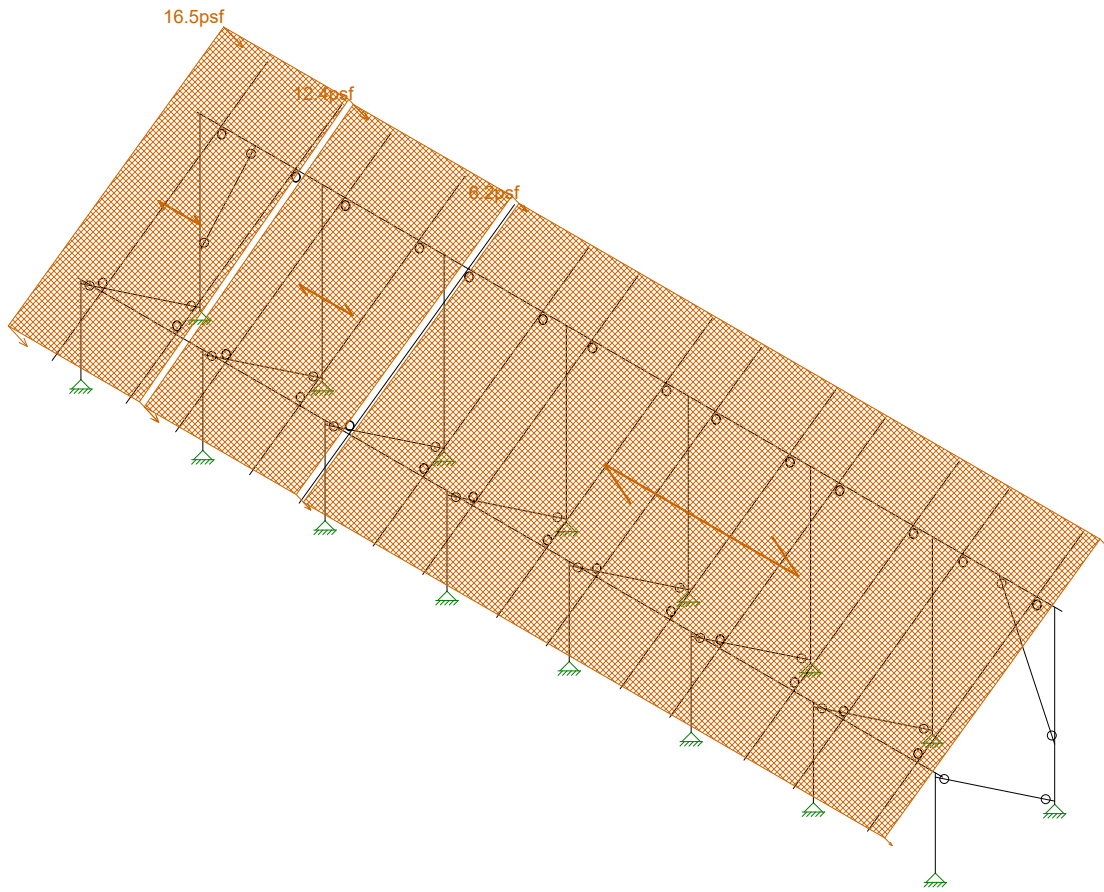

Loads: BLC 8, Wind A 90

Vector Structural Engineeri...	Ground Mount	SK - 11
STB		Apr 6, 2021 at 2:13 PM
U2716.114.191		Sunmodo Sunturf A5 v3 85x45.r3d

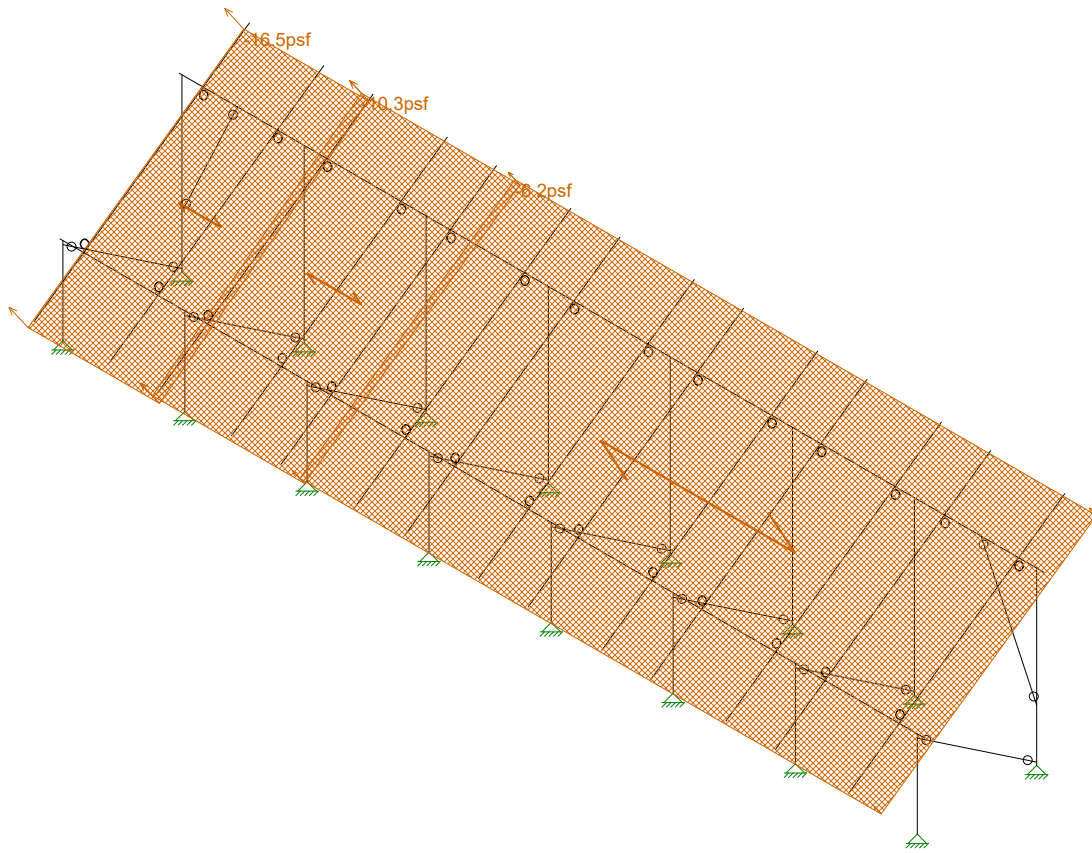

Loads: BLC 9, Wind B 90

Vector Structural Engineeri...
STB
U2716.114.191

Ground Mount

SK - 12

Apr 6, 2021 at 2:13 PM

Sunmodo Sunturf A5 v3 85x45.r3d

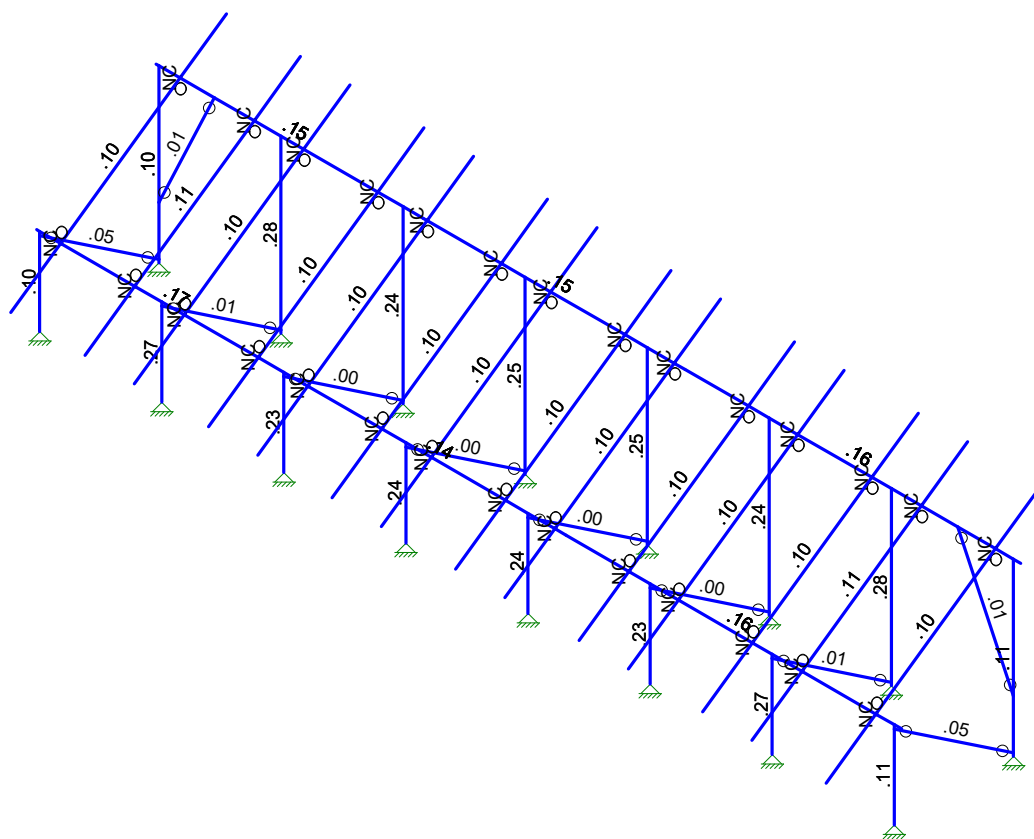
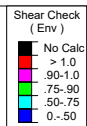

Member Shear Checks Displayed (Enveloped)
Envelope Only Solution

Vector Structural Engineeri...	Ground Mount	SK - 2
STB		Apr 6, 2021 at 2:11 PM
U2716.114.191		Sunmodo Sunturf A5 v3 85x45.r3d

(Global) Model Settings

Display Sections for Member Calcs	5
Max Internal Sections for Member Calcs	97
Include Shear Deformation?	Yes
Increase Nailing Capacity for Wind?	Yes
Include Warping?	Yes
Trans Load Btwn Intersecting Wood Wall?	Yes
Area Load Mesh (in^2)	144
Merge Tolerance (in)	.12
P-Delta Analysis Tolerance	0.50%
Include P-Delta for Walls?	Yes
Automatically Iterate Stiffness for Walls?	Yes
Max Iterations for Wall Stiffness	3
Gravity Acceleration (in/sec^2)	386.4
Wall Mesh Size (in)	24
Eigensolution Convergence Tol. (1.E-)	4
Vertical Axis	Y
Global Member Orientation Plane	XZ
Static Solver	Sparse Accelerated
Dynamic Solver	Accelerated Solver

Hot Rolled Steel Code	AISC 14th(360-10): ASD
Adjust Stiffness?	Yes(Iterative)
RISAConnection Code	AISC 14th(360-10): ASD
Cold Formed Steel Code	AISI S100-16: ASD
Wood Code	AWC NDS-15: ASD
Wood Temperature	< 100F
Concrete Code	ACI 318-14
Masonry Code	ACI 530-13: ASD
Aluminum Code	AA ADM1-15: ASD - Building
Stainless Steel Code	AISC 14th(360-10): ASD
Adjust Stiffness?	Yes(Iterative)

Number of Shear Regions	4
Region Spacing Increment (in)	4
Biaxial Column Method	Exact Integration
Parame Beta Factor (PCA)	.65
Concrete Stress Block	Rectangular
Use Cracked Sections?	Yes
Use Cracked Sections Slab?	No
Bad Framing Warnings?	No
Unused Force Warnings?	Yes
Min 1 Bar Diam. Spacing?	No
Concrete Rebar Set	REBAR SET ASTMA615
Min % Steel for Column	1
Max % Steel for Column	8



(Global) Model Settings, Continued

Seismic Code	ASCE 7-10
Seismic Base Elevation (in)	15600
Add Base Weight?	Yes
Ct X	.02
Ct Z	.02
T X (sec)	Not Entered
T Z (sec)	Not Entered
R X	3
R Z	3
Ct Exp. X	.75
Ct Exp. Z	.75
SD1	1
SDS	1
S1	1
TL (sec)	5
Risk Cat	I or II
Drift Cat	Other
Om Z	1
Om X	1
Cd Z	4
Cd X	4
Rho Z	1
Rho X	1

Hot Rolled Steel Properties

	Label	E [ksi]	G [ksi]	Nu	Therm (/1E5 F)	Density[lb/ft^3]	Yield[psi]	Ry	Fu[psi]	Rt
1	A992	29000	11154	.3	.65	490	50000	1.1	65000	1.1
2	A36 Gr.36	29000	11154	.3	.65	490	36000	1.5	58000	1.2
3	A572 Gr.50	29000	11154	.3	.65	490	50000	1.1	65000	1.1
4	A500 Gr.B R...	29000	11154	.3	.65	527	42000	1.4	58000	1.3
5	A500 Gr.B Re...	29000	11154	.3	.65	527	46000	1.4	58000	1.3
6	A53 Gr.B	29000	11154	.3	.65	490	35000	1.6	60000	1.2
7	A1085	29000	11154	.3	.65	490	50000	1.4	65000	1.3

Aluminum Properties

	Label	E [ksi]	G [ksi]	Nu	Therm (...Density[... Table B.4	kt	Ftu[psi]	Fty[psi]	Fcy[psi]	Fsu[psi]	Ct
1	3003-H14	10100	3787.5	.33	1.3 172.8 Table B.4-1	1	19000	16000	13000	12000	141
2	6061-T6	10100	3787.5	.33	1.3 172.8 Table B.4-2	1	38000	35000	35000	24000	141
3	6063-T5	10100	3787.5	.33	1.3 172.8 Table B.4-2	1	22000	16000	16000	13000	141
4	6063-T6	10100	3787.5	.33	1.3 172.8 Table B.4-2	1	30000	25000	25000	19000	141
5	5052-H34	10200	3787.5	.33	1.3 172.8 Table B.4-1	1	34000	26000	24000	20000	141
6	6061-T6 W	10100	3787.5	.33	1.3 172.8 Table B.4-1	1	24000	15000	15000	15000	141
7	6005-T5	10100	3787.5	.33	1.3 172.8 Table B.4-1	1	38000	35000	35000	24000	141

Hot Rolled Steel Section Sets

	Label	Shape	Type	Design List	Material	Design R...	A [in ²]	Iyy [in ⁴]	Izz [in ⁴]	J [in ⁴]
1	Post	Pipe 2.0 A21165	Column	Pipe	A572 Gr.50	Typical	.776	.499	.499	.998
2	Cross Beam	Pipe 2.5 A21168	Beam	Wide Flange	A572 Gr.50	Typical	.947	.907	.907	1.814
3	Diagonal Brace	1.5x1.5x0.083	HBrace	SquareTube	A572 Gr.50	Typical	.47	.158	.158	.236



Company : Vector Structural Engineering
 Designer : STB
 Job Number : U2716.114.191
 Model Name : Ground Mount

Apr 6, 2021
 2:13 PM
 Checked By: _____

Aluminum Section Sets

	Label	Shape	Type	Design List	Material	Design R...	A [in2]	Iyy [in4]	Izz [in4]	J [in4]
1	AL Posts	2.375ODX0.188	Column	Pipe	6005-T5	Typical	1.29	.778	.778	1.54
2	AL Brace	RT1.5x2x0.15625	VBrace	Rectangular Tubes	6005-T5	Typical	.996	.327	.524	.602
3	AL Rails	HR300 ALA	Beam	Rectangular Tubes	6005-T5	Typical	.736	.214	.727	.614
4	AL Cross Beam	Cross Rail	Beam	Rectangular Tubes	6005-T5	Typical	1.909	1.97	4.366	4.017

Member Area Loads (BLC 2 : Solar Panel Weight)

	Joint A	Joint B	Joint C	Joint D	Direction	Distribution	Magnitude[psf]
1	N197	N200	N199	N196	Y	A-B	-3

Member Area Loads (BLC 3 : Roof Live/Snow)

	Joint A	Joint B	Joint C	Joint D	Direction	Distribution	Magnitude[psf]
1	N197	N200	N199	N196	PY	A-B	-27

Member Area Loads (BLC 4 : Wind A 0 deg)

	Joint A	Joint B	Joint C	Joint D	Direction	Distribution	Magnitude[psf]
1	N197	N200	N201	N198	Perp	A-B	-37.2
2	N198	N201	N199	N196	Perp	A-B	-37.2

Member Area Loads (BLC 5 : Wind B 0 deg)

	Joint A	Joint B	Joint C	Joint D	Direction	Distribution	Magnitude[psf]
1	N197	N200	N201	N198	Perp	A-B	-50.3
2	N198	N201	N199	N196	Perp	A-B	-11.7

Member Area Loads (BLC 6 : Wind A 180 deg)

	Joint A	Joint B	Joint C	Joint D	Direction	Distribution	Magnitude[psf]
1	N197	N200	N201	N198	Perp	A-B	44.8
2	N198	N201	N199	N196	Perp	A-B	43.4

Member Area Loads (BLC 7 : Wind B 180 deg)

	Joint A	Joint B	Joint C	Joint D	Direction	Distribution	Magnitude[psf]
1	N197	N200	N201	N198	Perp	A-B	22
2	N198	N201	N199	N196	Perp	A-B	55.1

Member Area Loads (BLC 8 : Wind A 90)

	Joint A	Joint B	Joint C	Joint D	Direction	Distribution	Magnitude[psf]
1	N197	N203	N202	N196	Perp	A-B	16.5
2	N203	N209	N208	N202	Perp	A-B	12.4
3	N209	N200	N199	N208	Perp	A-B	6.2

Member Area Loads (BLC 9 : Wind B 90)

	Joint A	Joint B	Joint C	Joint D	Direction	Distribution	Magnitude[psf]
1	N197	N203	N202	N196	Perp	A-B	-16.5
2	N203	N209	N208	N202	Perp	A-B	-10.3
3	N209	N200	N199	N208	Perp	A-B	-6.2

Basic Load Cases

	BLC Description	Category	X Gravity	Y Gravity	Z Gravity	Joint	Point	Distributed	Area(M...Surface...
1	Self Weight	DL		-1.05					
2	Solar Panel Weight	DL							1

NOTES: UNLESS OTHERWISE SPECIFIED
 1. DIMENSIONS SHOWN ARE INCHES [MILLIMETERS].

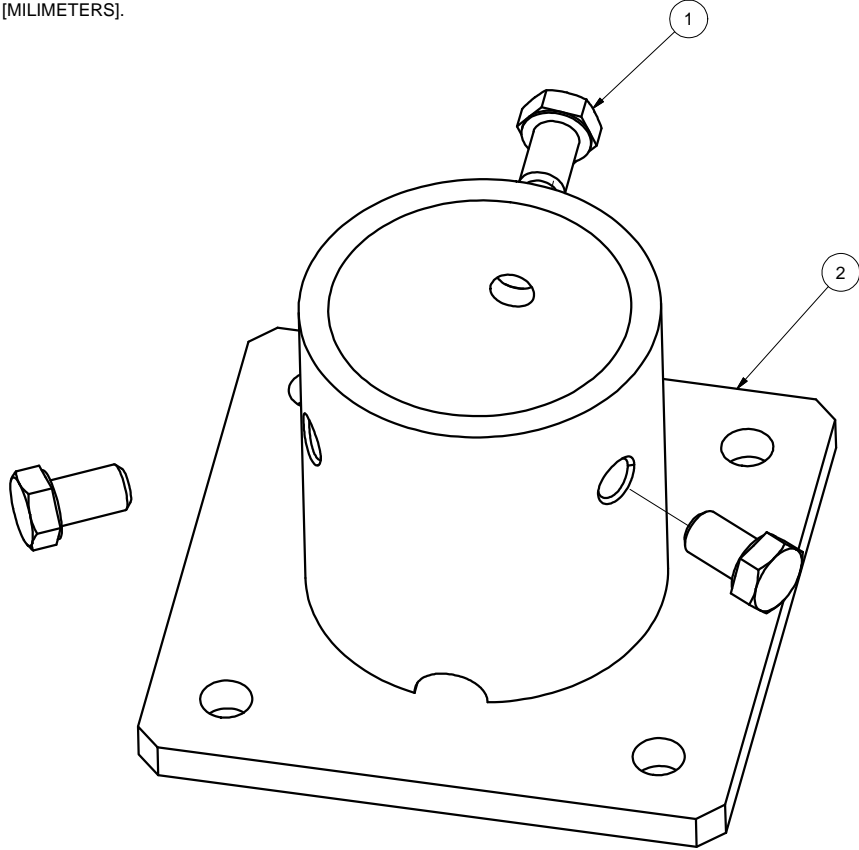

REVISIONS			
REV	DESCRIPTION	BY	DATE
A	INITIAL RELEASE	LWF	10/20/2016

2	A21120-001	2" PIPE BASE	1
1	B15018-011	HEX CAP SCREW 3/8-16 X 5/8	3
ITEM	PART NUMBER	DESCRIPTION	QTY
MATERIAL		SEE NOTES	
Third Angle Projection:			
GENERAL SPECIFICATIONS		Sunmodo Corp. 1905 E 5TH STREET, STE A, VANCOUVER, WA 98661	
Tolerances		TITLE	
X.XXX ±0.01 [0.25mm] X.XX ±0.02 [0.50mm] X.X ±0.039 [1.0mm] Unless otherwise spec'd		2" PIPE BASE KIT	
DRAWN BY		DATE	
LWF		10/20/2016	
CHECKED BY		DRAWING NUMBER	
		B K10268-001	
APPROVALS		SCALE: NONE	
		SHEET 1 of 1	

THIS DRAWING IS CONFIDENTIAL PROPERTY OF SUNMODO AND ITS CONTENTS MAY NOT BE DISCLOSED WITHOUT THE PRIOR WRITTEN CONSENT OF SUNMODO CORP.

NOTES: UNLESS OTHERWISE SPECIFIED

1. DIMENSIONS SHOWN ARE INCHES [MILIMETERS].
2. MATERAIL: ALUMINUM 6005-T5.
FINISH: CLEAR ANODIZED 10 μ m THICK.
3. THE UNSPECIFIED DIMENSIONS ARE SPECIFIED BY 2D CAD FILE.

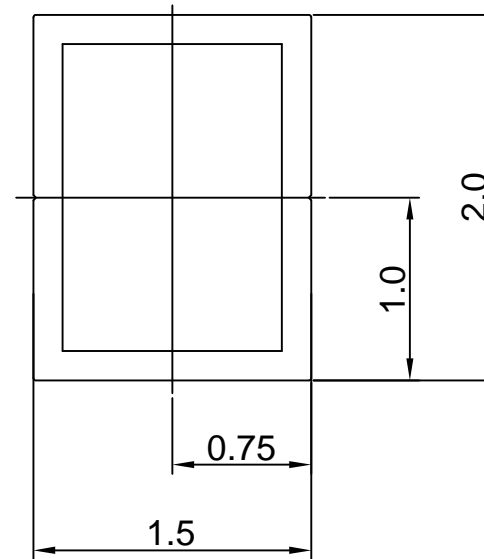

Section properties:

Weight: 1.156 lbs/ft

Area: 0.992 in²

Perimeter: 12.601 in

Bounding Box: X: -1.000,1.000

Y: -0.750, 0.750

Centroid:(0.000,0.000)

Moments of Inertia(in⁴): I_x=0.506,I_y=0.322

Section modulus in bending(in³): W_x=0.675,W_y=0.322

Radii of Gyration: X: 0.714, Y: 0.570

MATERIAL		SEE NOTES	
Third Angle Projection:			
GENERAL SPECIFICATIONS			
All Dimensions in inches [millimeters]			
Tolerances			
X.XXX ± 0.01 [0.25mm]	Break all sharp edges		
X.XX ± 0.02 [0.50mm]	.010-.020 unless		
X.X ± 0.039 [1.0mm]	otherwise specified.		
DRAWN BY		DATE	
zcg		03/12/2014	
CHECKED BY			
APPROVALS			
		1905 E 5TH STREET, SUITE A, VANCOUVER, WA 98661	
		TITLE	
		1.5X2 AL TUBE BRACE EXTRUSION	
		DRAWING NUMBER	
		A20164	
		SCALE: NONE	
		SHEET 1 of 1	

REVISIONS			
REV	DESCRIPTION	BY	DATE
A	ADDED BOTTOM CHANNEL & CHANGED ONE 3/8 CHANNEL TO 1/4	zcg	02/21/2013

NOTES: UNLESS OTHERWISE SPECIFIED

1. DIMENSIONS SHOWN ARE INCHES [MILIMETERS].
2. MATERAIL: ALUMINUM 6005-T5.
FINISH: CLEAR ANODIZED 15 μ m THICK.
3. THE UNSPECIFIED DIMENSIONS ARE SPECIFIED BY 2D CAD FILE.

2X 1/4 BOLT SLOT

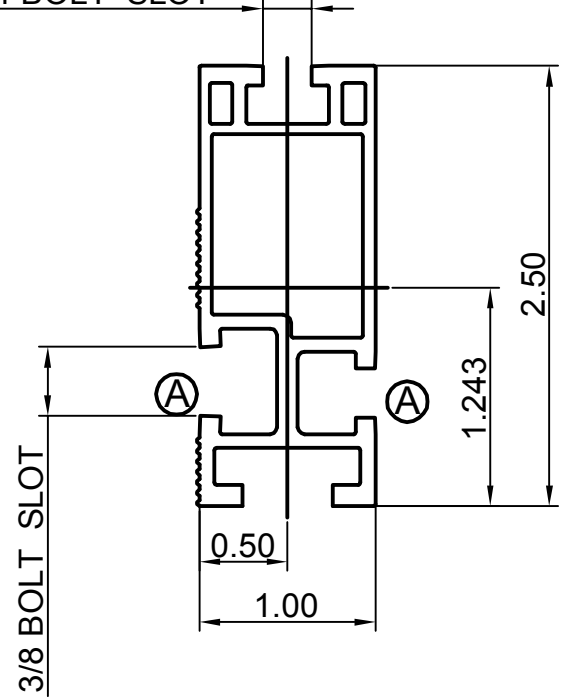

Section properties:

Weight: 0.850 lbs/ft
 Area: 0.723 in²
 Perimeter: 17.325 in
 Bounding Box: X: -0.500,0.500
 Y: -1.243,1.257

Centroid:(0.000,0.000)
 Moments of Inertia(in⁴): I_x=0.486,I_y=0.095
 Section modulus in bending(in³): W_x=0.387,W_y=0.190
 Radii of Gyration: X: 0.820, Y: 0.363

MATERIAL SEE NOTES	
Third Angle Projection:	
GENERAL SPECIFICATIONS All Dimensions in inches [millimeters]	
Tolerances	
X.XXX ± 0.01 [0.25mm]	Break all sharp edges
X.XX ± 0.02 [0.50mm]	.010-.020 unless
X.X ± 0.039 [1.0mm]	otherwise specified.
Unless otherwise spec'd	
DRAWN BY zcg	DATE 02/21/2013
CHECKED BY	
APPROVALS	

Sunmodo Corp.	
1905 E 5TH STREET, SUITE A, VANCOUVER, WA 98661	
TITLE HELIO STANDARD RAIL	
DRAWING NUMBER B A20144	
SCALE: NONE	SHEET 1 of 1

4

3

2

1

NOTES: UNLESS OTHERWISE SPECIFIED

- 1. DIMENSIONS SHOWN ARE INCHES [MILIMETERS].
- 2. MATERIAL: 6005-T5.
FINISH: CLEAR ANODIZED 10um THICK.
- 3. THE UNSPECIFIED RADII ARE .02" MAX.
- 4. THE UNSPECIFIED DIMENSIONS ARE SPECIFIED BY 2D CAD FILE.

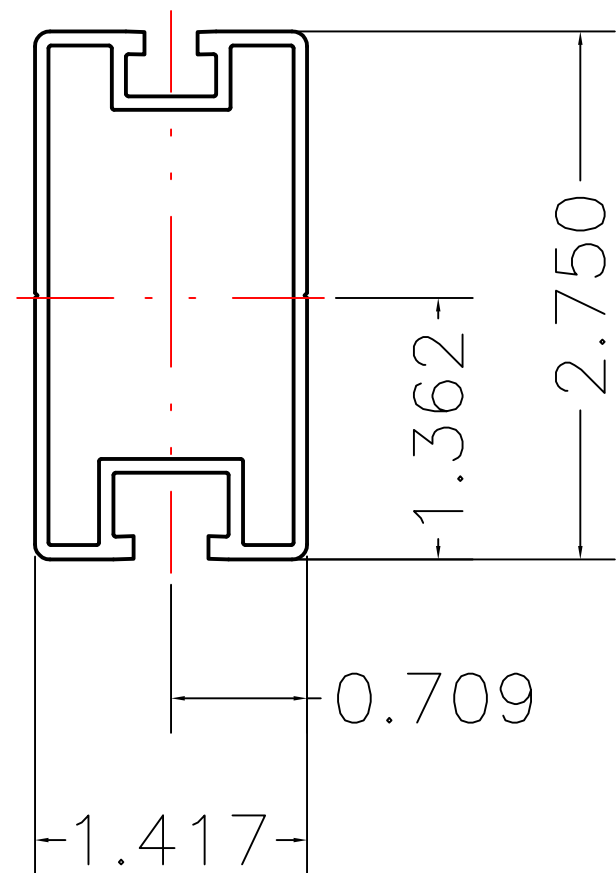

Section properties:

Weight: 0.862 lbs/ft
 Area: 0.736 in²
 Perimeter: 19.824 in
 Bounding Box: X: -0.709,0.709
 Y: -1.362,1.388
 Centroid:(0.000,0.000)
 Moments of Inertia(in⁴): I_x=0.727,I_y=0.214
 Section modulus in bending(in³): W_x=0.524,W_y=0.302
 Radii of Gyration: X: 994, Y: 0.539

MATERIAL SEE NOTES	
Third Angle Projection:	
GENERAL SPECIFICATIONS All Dimensions in inches [millimeters]	
Tolerances	
X.XXX ±0.01 [0.25mm]	Break all sharp edges .010-.020 unless otherwise specified.
X.XX ±0.02 [0.50mm]	
X.X ±0.039 [1.0mm]	
Unless otherwise spec'd	
DRAWN BY KYY	DATE 01/18/2018
CHECKED BY	
APPROVALS	

SunModo Corp.	
14800 NE 65TH STREET, VANCOUVER WA 98682	
TITLE RAIL, HR300 (SUNRAY), EXTRUSION	
B	DRAWING NUMBER A20288
SCALE: NONE	SHEET 1 of 1

THIS DRAWING IS CONFIDENTIAL PROPERTY OF SUNMODO AND ITS CONTENTS MAY NOT BE DISCLOSED WITHOUT THE PRIOR WRITTEN CONSENT OF SUNMODO CORP.

4

3

2

1

REV	DESCRIPTON	BY	DATE
A	0.44 WAS 0.41, 0.44 WAS 0.33	LWF	11/30/2015

NOTES: UNLESS OTHERWISE SPECIFIED

- 1. DIMENSIONS SHOWN ARE INCHES [MILIMETERS].
- 2. MATERIAL: ALUMINUM 6005-T5.
FINISH: CLEAR ANODIZED 15 μm THICK.
- 3. THE UNSPECIFIED DIMENSIONS ARE SPECIFIED BY 2D CAD FILE.

2X 1/4 BOLT SLOT

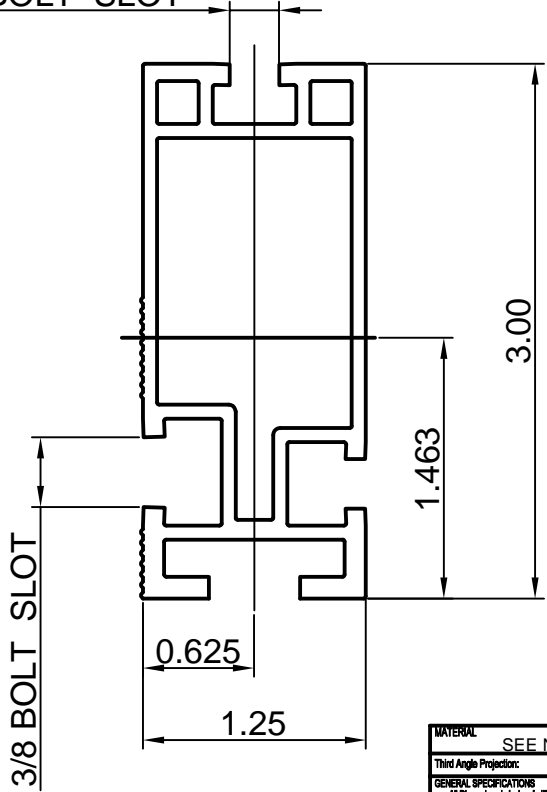

Section properties:

Weight: 1.151 lbs/ft
 Area: 0.980 in²
 Perimeter: 22.104 in
 Bounding Box: X: -0.625,0.625
 Y: -1.463,1.537
 Centroid:(0.000,0.000)
 Moments of Inertia(in⁴): Ix=1.047,Iy=0.207
 Section modulus in bending(in³): Wx=0.681,Wy=0.331
 Radii of Gyration: X: 1.034, Y: 0.460

MATERIAL		SEE NOTES	
Third Angle Projection			
GENERAL SPECIFICATIONS			
All Dimensions in Inches [millimeters]			
Tolerances			
XXXX ±0.01 (0.25mm)			
XX ±0.02 (0.50mm)			
X ±0.03 (1.0mm)			
Unless otherwise specified.			
DRAWN BY		DATE	
ZCJ		02/21/2015	
CHECKED BY		DATE	
APPROVALS		DATE	
Sunmodo Corp.		1905 E 5TH STREET, SUITE A, VANCOUVER, WA 98661	
TITLE		HELIO HEAVY RAIL	
DRAWING NUMBER		A20145	
SCALE:		NONE	
SHEET		1 of 1	

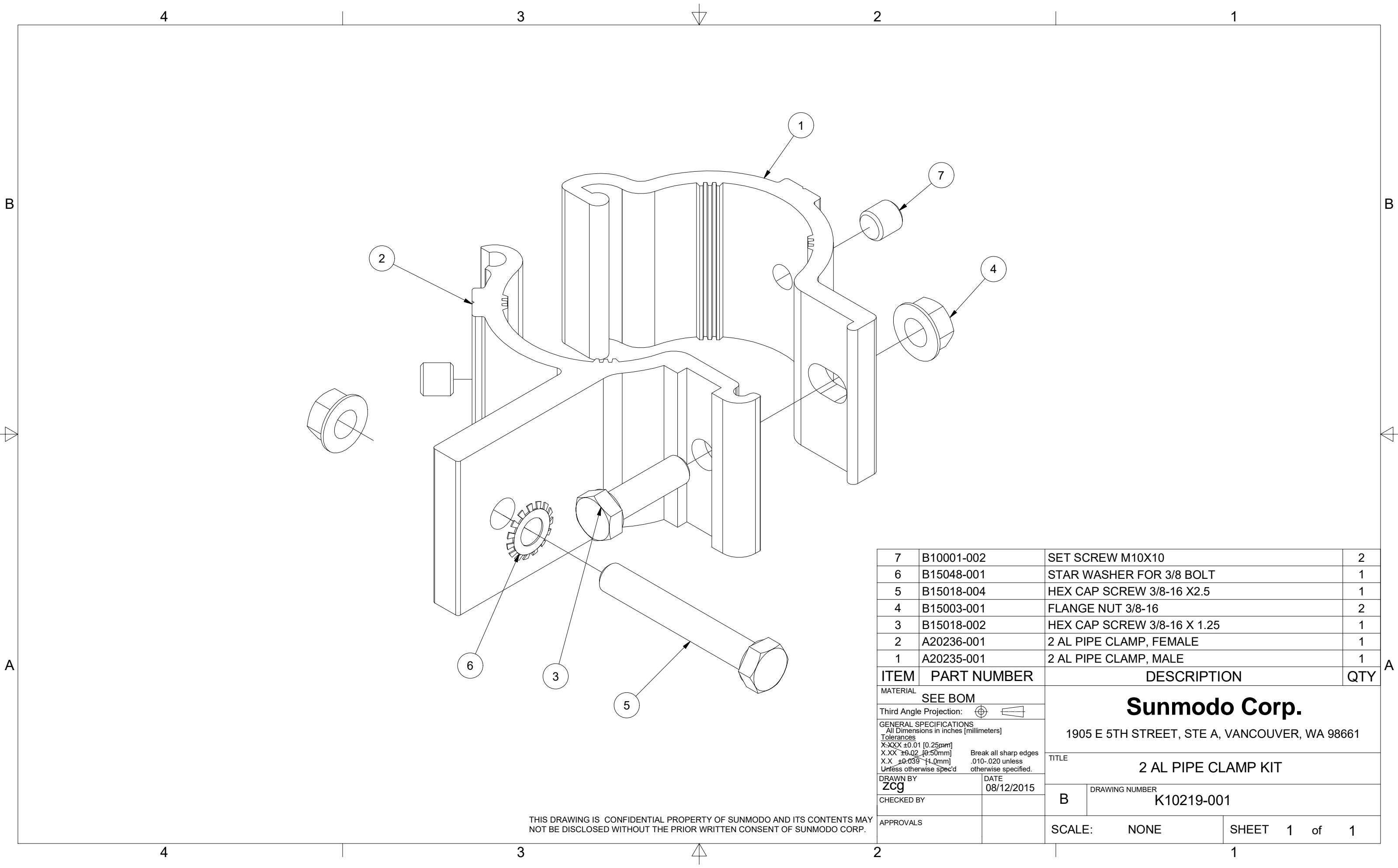

7	B10001-002	SET SCREW M10X10	2
6	B15048-001	STAR WASHER FOR 3/8 BOLT	1
5	B15018-004	HEX CAP SCREW 3/8-16 X2.5	1
4	B15003-001	FLANGE NUT 3/8-16	2
3	B15018-002	HEX CAP SCREW 3/8-16 X 1.25	1
2	A20236-001	2 AL PIPE CLAMP, FEMALE	1
1	A20235-001	2 AL PIPE CLAMP, MALE	1

ITEM	PART NUMBER	DESCRIPTION	QTY
MATERIAL		SEE BOM	
Third Angle Projection:			
GENERAL SPECIFICATIONS All Dimensions in inches (millimeters)			
Tolerances			
X.XXX ±0.01 [0.25mm]		Break all sharp edges	
X.XX ±0.02 [0.50mm]		.010-.020 unless	
X.X ±0.039 [1.0mm]		otherwise specified.	
DRAWN BY		DATE	
zcg		08/12/2015	
CHECKED BY		TITLE	
		2 AL PIPE CLAMP KIT	
APPROVALS		DRAWING NUMBER	
		B K10219-001	
SCALE:		NONE	SHEET 1 of 1

THIS DRAWING IS CONFIDENTIAL PROPERTY OF SUNMODO AND ITS CONTENTS MAY NOT BE DISCLOSED WITHOUT THE PRIOR WRITTEN CONSENT OF SUNMODO CORP.

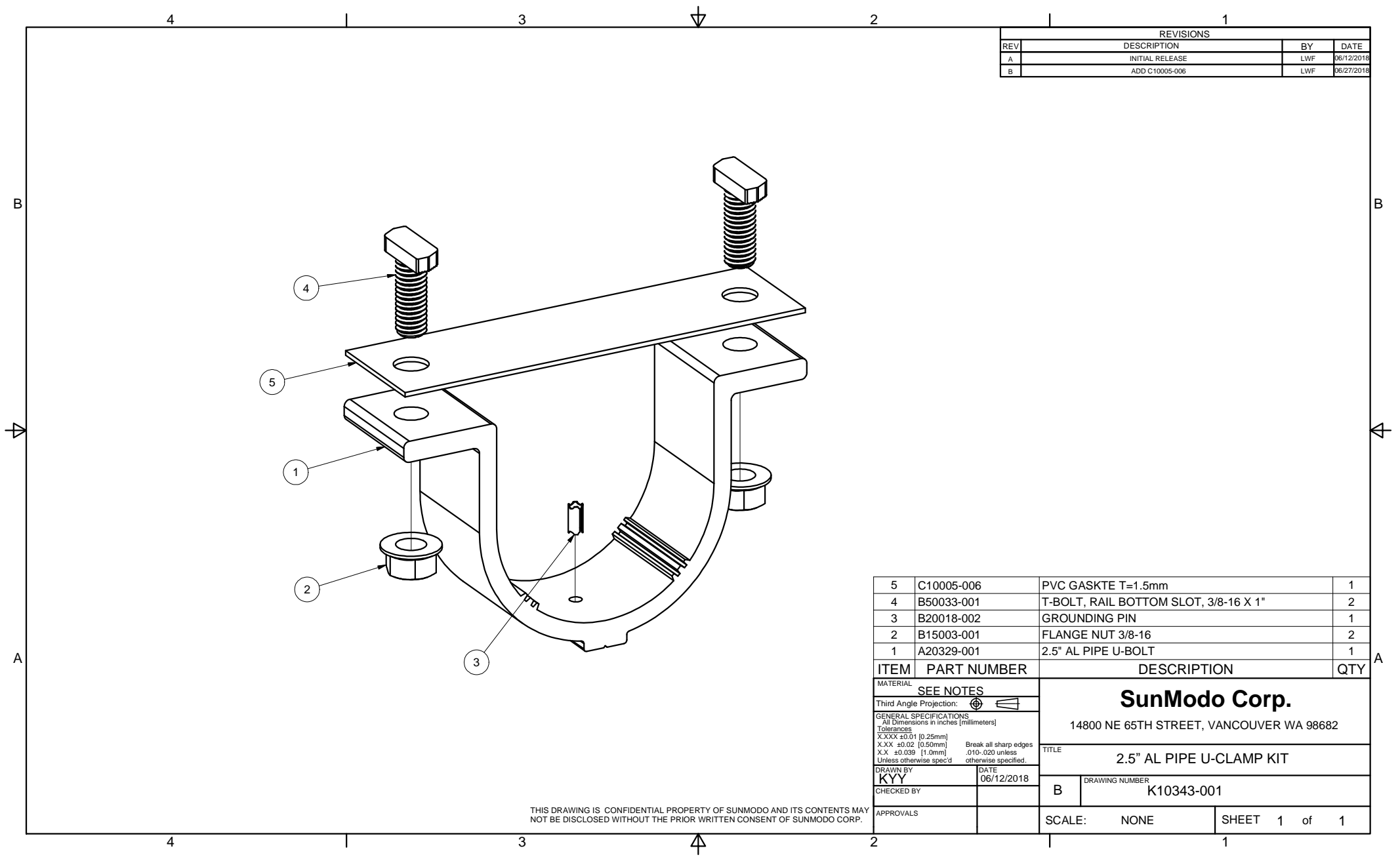

REVISIONS			
REV	DESCRIPTION	BY	DATE
A	INITIAL RELEASE	LWF	06/12/2018
B	ADD C10005-006	LWF	06/27/2018

ITEM	PART NUMBER	DESCRIPTION	QTY
5	C10005-006	PVC GASKTE T=1.5mm	1
4	B50033-001	T-BOLT, RAIL BOTTOM SLOT, 3/8-16 X 1"	2
3	B20018-002	GROUNDING PIN	1
2	B15003-001	FLANGE NUT 3/8-16	2
1	A20329-001	2.5" AL PIPE U-BOLT	1

MATERIAL		SEE NOTES	
Third Angle Projection:			
GENERAL SPECIFICATIONS		<p style="text-align: center;">SunModo Corp.</p> <p style="text-align: center;">14800 NE 65TH STREET, VANCOUVER WA 98682</p>	
<small>All Dimensions in inches [millimeters]</small> <small>Tolerances</small> X.XXX ±0.01 [0.25mm] Break all sharp edges X.XX ±0.02 [0.50mm] .010-.020 unless X.X ±0.039 [1.0mm] otherwise specified. Unless otherwise spec'd			
TITLE		2.5" AL PIPE U-CLAMP KIT	
DRAWN BY	DATE	DRAWING NUMBER	
KYY	06/12/2018	B K10343-001	
CHECKED BY			
APPROVALS		SCALE: NONE	SHEET 1 of 1

THIS DRAWING IS CONFIDENTIAL PROPERTY OF SUNMODO AND ITS CONTENTS MAY NOT BE DISCLOSED WITHOUT THE PRIOR WRITTEN CONSENT OF SUNMODO CORP.

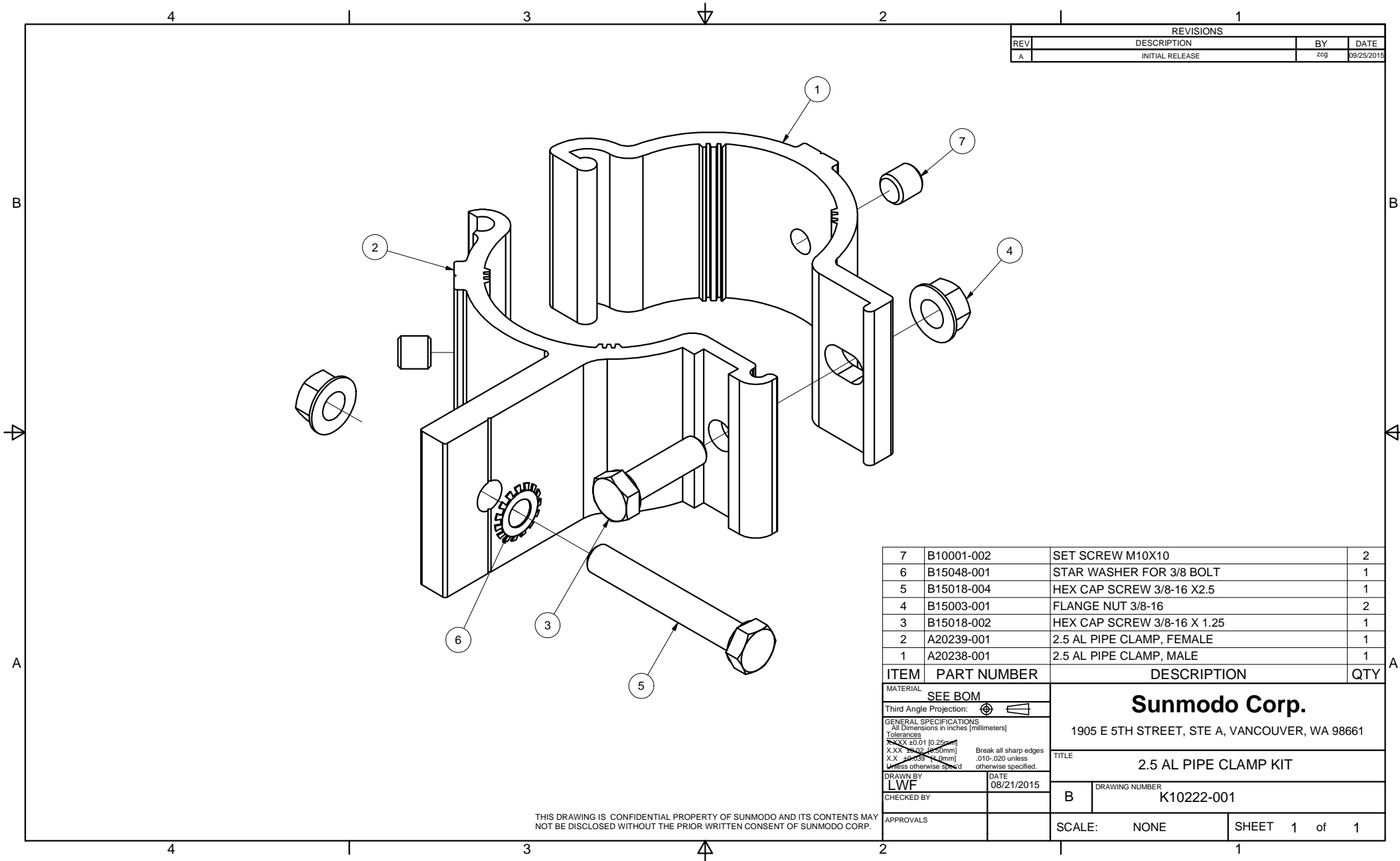

REVISIONS			
REV	DESCRIPTION	BY	DATE
A	INITIAL RELEASE	zcg	09/25/2015

ITEM	PART NUMBER	DESCRIPTION	QTY
7	B10001-002	SET SCREW M10X10	2
6	B15048-001	STAR WASHER FOR 3/8 BOLT	1
5	B15018-004	HEX CAP SCREW 3/8-16 X2.5	1
4	B15003-001	FLANGE NUT 3/8-16	2
3	B15018-002	HEX CAP SCREW 3/8-16 X 1.25	1
2	A20239-001	2.5 AL PIPE CLAMP, FEMALE	1
1	A20238-001	2.5 AL PIPE CLAMP, MALE	1

MATERIAL		SEE BOM	
Third Angle Projection:			
GENERAL SPECIFICATIONS All Dimensions in inches [millimeters] Tolerances X.XX ±0.01 [0.25mm] X.XX ±0.02 [0.50mm] X.X ±0.03 [0.75mm] Unless otherwise specified.			
DRAWN BY		DATE	
LWF		08/21/2015	
CHECKED BY		B	
APPROVALS		SCALE: NONE	
		SHEET 1 of 1	

Sunmodo Corp.
 1905 E 5TH STREET, STE A, VANCOUVER, WA 98661

TITLE: **2.5 AL PIPE CLAMP KIT**

DRAWING NUMBER: **K10222-001**

THIS DRAWING IS CONFIDENTIAL PROPERTY OF SUNMODO AND ITS CONTENTS MAY NOT BE DISCLOSED WITHOUT THE PRIOR WRITTEN CONSENT OF SUNMODO CORP.

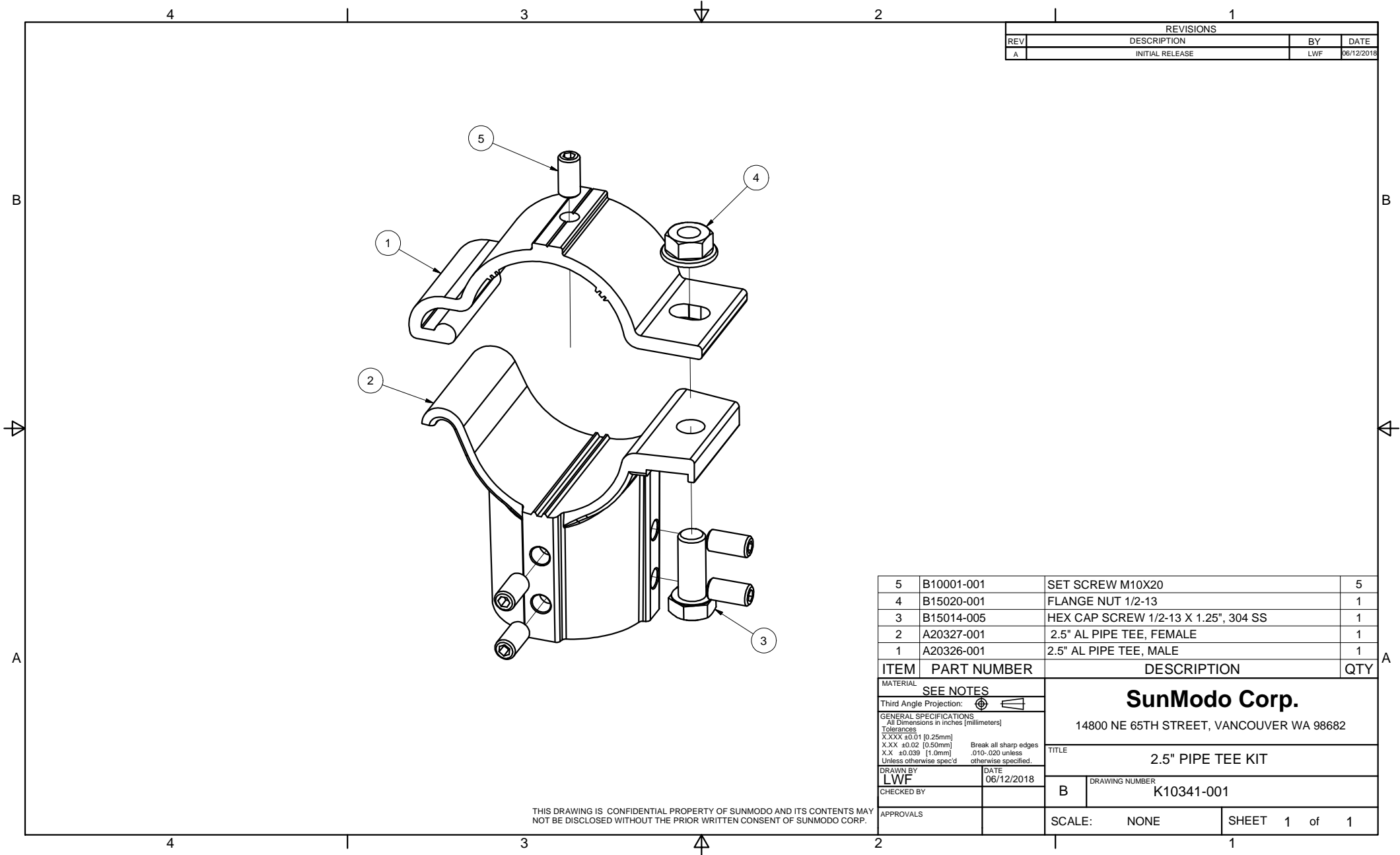

REVISIONS			
REV	DESCRIPTION	BY	DATE
A	INITIAL RELEASE	LWF	06/12/2018

ITEM	PART NUMBER	DESCRIPTION	QTY
5	B10001-001	SET SCREW M10X20	5
4	B15020-001	FLANGE NUT 1/2-13	1
3	B15014-005	HEX CAP SCREW 1/2-13 X 1.25", 304 SS	1
2	A20327-001	2.5" AL PIPE TEE, FEMALE	1
1	A20326-001	2.5" AL PIPE TEE, MALE	1

MATERIAL		SEE NOTES	
Third Angle Projection:			
GENERAL SPECIFICATIONS		SunModo Corp. 14800 NE 65TH STREET, VANCOUVER WA 98682	
Tolerances		TITLE	
X.XXX ±0.01 [0.25mm] X.XX ±0.02 [0.50mm] X.X ±0.039 [1.0mm] Unless otherwise spec'd		2.5" PIPE TEE KIT	
DRAWN BY		DATE	
LWF		06/12/2018	
CHECKED BY		DRAWING NUMBER	
		B K10341-001	
APPROVALS		SCALE: NONE SHEET 1 of 1	

THIS DRAWING IS CONFIDENTIAL PROPERTY OF SUNMODO AND ITS CONTENTS MAY NOT BE DISCLOSED WITHOUT THE PRIOR WRITTEN CONSENT OF SUNMODO CORP.

REVISIONS			
REV	DESCRIPTION	BY	DATE
A	INITIAL RELEASE	LWF	06/12/2018

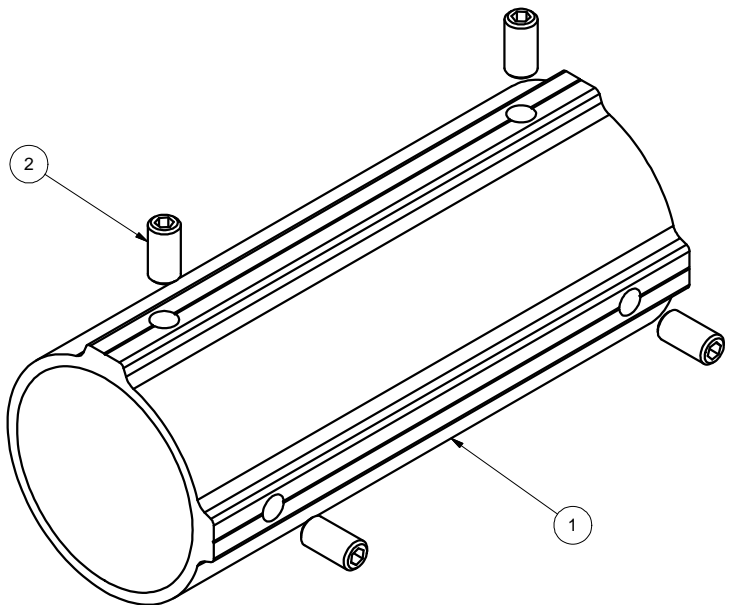

2	B10001-001	SET SCREW M10X20	4
1	A20328-001	2.5" PIPE SPLICE	1
ITEM	PART NUMBER	DESCRIPTION	QTY
MATERIAL		SEE NOTES	
Third Angle Projection:			
GENERAL SPECIFICATIONS		SunModo Corp. 14800 NE 65TH STREET, VANCOUVER WA 98682	
All Dimensions in inches [millimeters] Tolerances X.XXX ±0.01 [0.25mm] X.XX ±0.02 [0.50mm] X.X ±0.039 [1.0mm] Unless otherwise spec'd		Break all sharp edges .010-.020 unless otherwise specified.	
DRAWN BY		TITLE	
LWF		2.5" PIPE SPLICE KIT	
DATE		DRAWING NUMBER	
06/12/2018		B K10342-001	
CHECKED BY		SCALE: NONE	
APPROVALS		SHEET 1 of 1	

THIS DRAWING IS CONFIDENTIAL PROPERTY OF SUNMODO AND ITS CONTENTS MAY NOT BE DISCLOSED WITHOUT THE PRIOR WRITTEN CONSENT OF SUNMODO CORP.

NOTES: UNLESS OTHERWISE SPECIFIED

1. DIMENSIONS SHOWN ARE INCHES [MILIMETERS].
2. MATERIAL:HIGH STRENGTH STEEL PIPE OR TUBE.
3. FINISH: HOT DIP GALVANIZE PER ASTM A123 / A123M - 02.

MINIMUM 50 KSI YIELD STRESS.

4. BREAK ALL BURRS AND SHARP EDGES.

5. ALL WELDING MUST BE IN COMPLIANCE WITH AWS CODE D1;1.

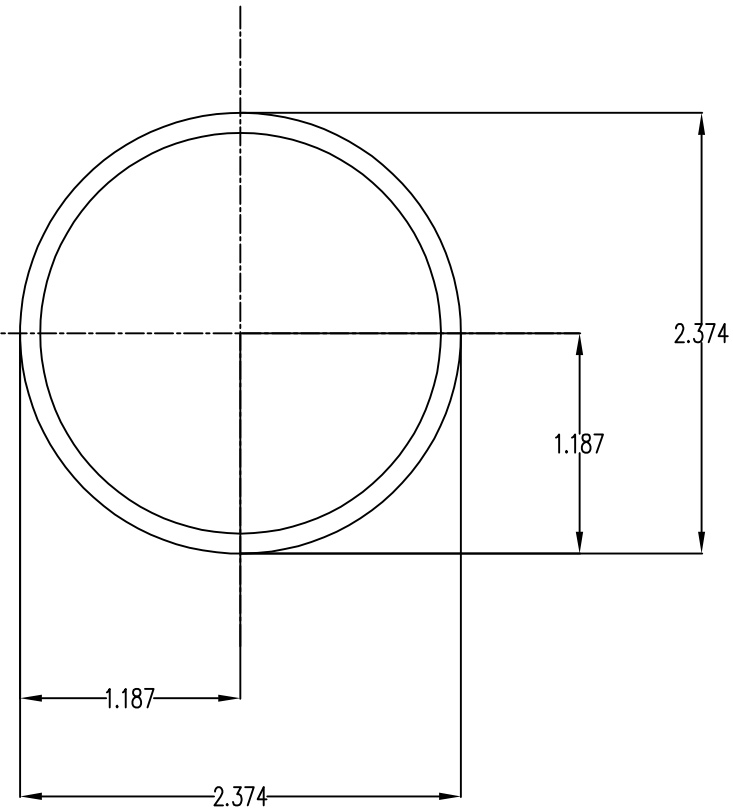

Section properties:

Weight: 2.641 lbs/ft

Area: 0.776 in²

Perimeter: 14.238 in

Bounding Box: X: -1.187,1.187

Y: -1.187,1.187

Centroid:(0.000,0.000)

Moments of Inertia(in⁴): Ix=0.499,Iy=0.499

Section modulus in bending(in³): Wx=0.420,Wy=0.420

Radii of Gyration: X: 0.802, Y: 0.802

MATERIAL		SEE NOTES		Sunmodo Corp. 14800 NE 85TH STREET, VANCOUVER WA 98682	
Third Angle Projection:					
GENERAL SPECIFICATIONS				TITLE	
All Dimensions in Inches (millimeters)				PIPE, HSS, 2.375" OD X 12 GAUGE,L=XXX	
Tolerances				Break all sharp edges .010-.020 unless otherwise specified.	
XXX ±0.01 (0.25mm)					
XX ±0.02 (0.50mm)					
X ±0.050 (1.27mm)					
Unless otherwise specified					
DRAWN BY	DATE	B		DRAWING NUMBER	
LWF	04/03/2019			A21165	
CHECKED BY					
APPROVALS				SCALE: NONE SHEET 1 of 1	

NOTES: UNLESS OTHERWISE SPECIFIED

1. DIMENSIONS SHOWN ARE INCHES [MILIMETERS].
2. MATERAIL:HIGH STRENGTH STEEL PIPE OR TUBE.
3. FINISH: HOT DIP GALVANIZE PER ASTM A123 / A123M - 02.

MINIMUM 50 KSI YIELD STRESS.

4. BREAK ALL BURRS AND SHARP EDGES.
5. ALL WELDING MUST BE IN COMPLIANCE WITH AWS CODE D1;1.

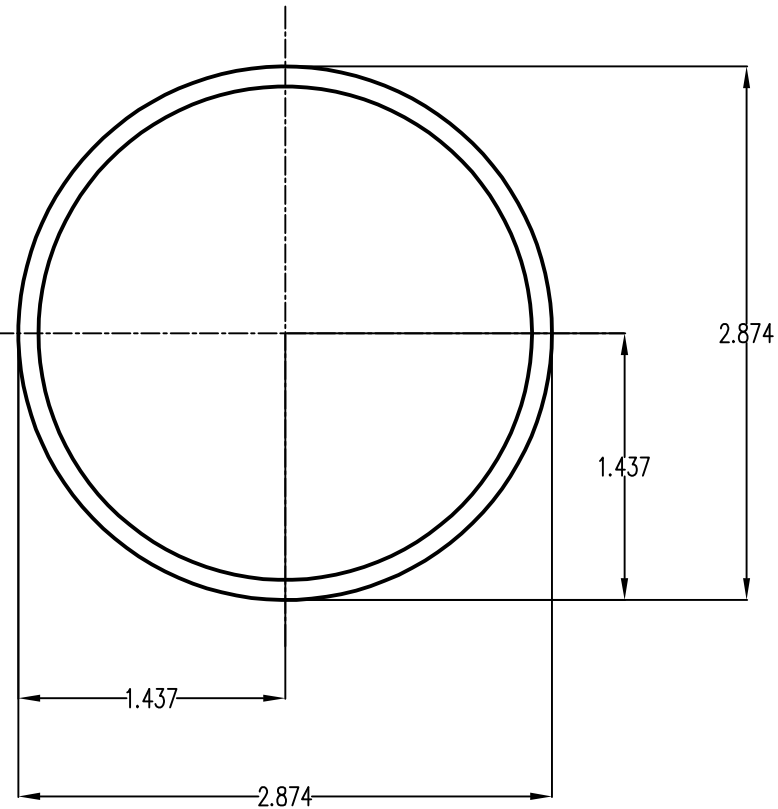

Section properties:

Weight: 3.201 lbs/ft

Area: 0.941 in²

Perimeter: 17.378 in

Bounding Box: X: -1.437,1.437

Y: -1.437,1.437

Centroid:(0.000,0.000)

Moments of Inertia(in⁴): Ix=0.901,Iy=0.901

Section modulus in bending(in³): Wx=0.627,Wy=0.627

Radii of Gyration: X: 0.979, Y: 0.979

MATERIAL		SEE NOTES		Sunmodo Corp. 14800 NE 85TH STREET, VANCOUVER WA 98682	
Third Angle Projection:					
GENERAL SPECIFICATIONS All Dimensions in Inches (millimeters)				TITLE	
Tolerances XXX ±0.01 (0.25mm) XX ±0.02 (0.50mm) X ±0.030 (1.0mm) Unless otherwise specified				PIPE, HSS, 2.875" OD X 12 GAUGE,L=XXX	
DRAWN BY LWF		DATE 04/03/2019		DRAWING NUMBER A21168	
CHECKED BY				B	
APPROVALS				SCALE: NONE SHEET 1 of 1	