



Project Number: U2716-097-191

April 22, 2021

Sunmodo
14800 NE 65th Street
Vancouver, WA 98682

**REFERENCE: Sunmodo Sunturf Ground Mount B3 (85x45)
Ground Mount PV Array Installation**

To Whom It May Concern:

Per request of Sunmodo, we have been asked to prepare the structural design of a ground-mounted PV solar array system with several foundation options as shown in the attached calculations. The adopted building code in this jurisdiction is the International Building Code, 2018 Edition. Vector Structural Engineering requires that we review each site specific install, and we are not liable for installs at site specific locations we have not reviewed. The following design parameters are used in our analysis:

- Minimum Design Loads for Buildings and Other Structures (ASCE 7-16)
- Design wind speed for risk category I structures: 105 mph
- Wind exposure: C
- Ground snow load: 30 psf
- The ground screws and helical piers must be tested to 1.5 times uplift and 2.0 times lateral reactions found in the table below. A minimum of one ground screw or helical pier must be tested.

Load (ASD)	Value (lbs)	Factor of Safety	Test Value (lbs)
UPLIFT	2698	1.5	4047
LATERAL	1798	2	3596

Foundation concrete shall have a minimum compressive strength of 2500 psi at 28 days. Cement for all concrete shall be Type I or II with a minimum of 6% entrained air with a water/cement ratio of 0.50. Maximum aggregate size shall be 3/4". No special inspection of concrete strength is required.

Footings are designed based on an allowable soil bearing pressure of 1500 psf an allowable skin friction of 250 psf, an allowable lateral bearing pressure of 150 pcf, and a coefficient of friction of 0.3. Vector Structural Engineering strongly recommends independent soils testing be performed by a licensed geotechnical engineer to verify the assumed soil parameters.

All ground mounts are to be installed per manufacturer's recommendations. The use of solar panel support span tables provided by the manufacturer is allowed only where the site conditions and solar panel configuration match the description of the span tables. Electrical engineering is beyond our scope. All work performed must be in accordance with accepted industry-wide methods and applicable safety standards. Vector Structural Engineering assumes no responsibility for improper installation of the solar panels.

Very truly yours,

VECTOR STRUCTURAL ENGINEERING, LLC
CO Firm License: 20181009799

Kelly Springer, P.E.
License: 56677 - Expires: 10/31/2021
Project Engineer



Enclosures

KGS/stb



JOB NO. U2716-097-191
PROJECT SUNMODO SUNTURF GROUND MOUNTS B3
SUBJECT ALL OPTIONS

651 W GALENA PARK BLVD. #101 (801) 990-1775
DRAPER, UTAH 84020 (801) 990-1776 FAX

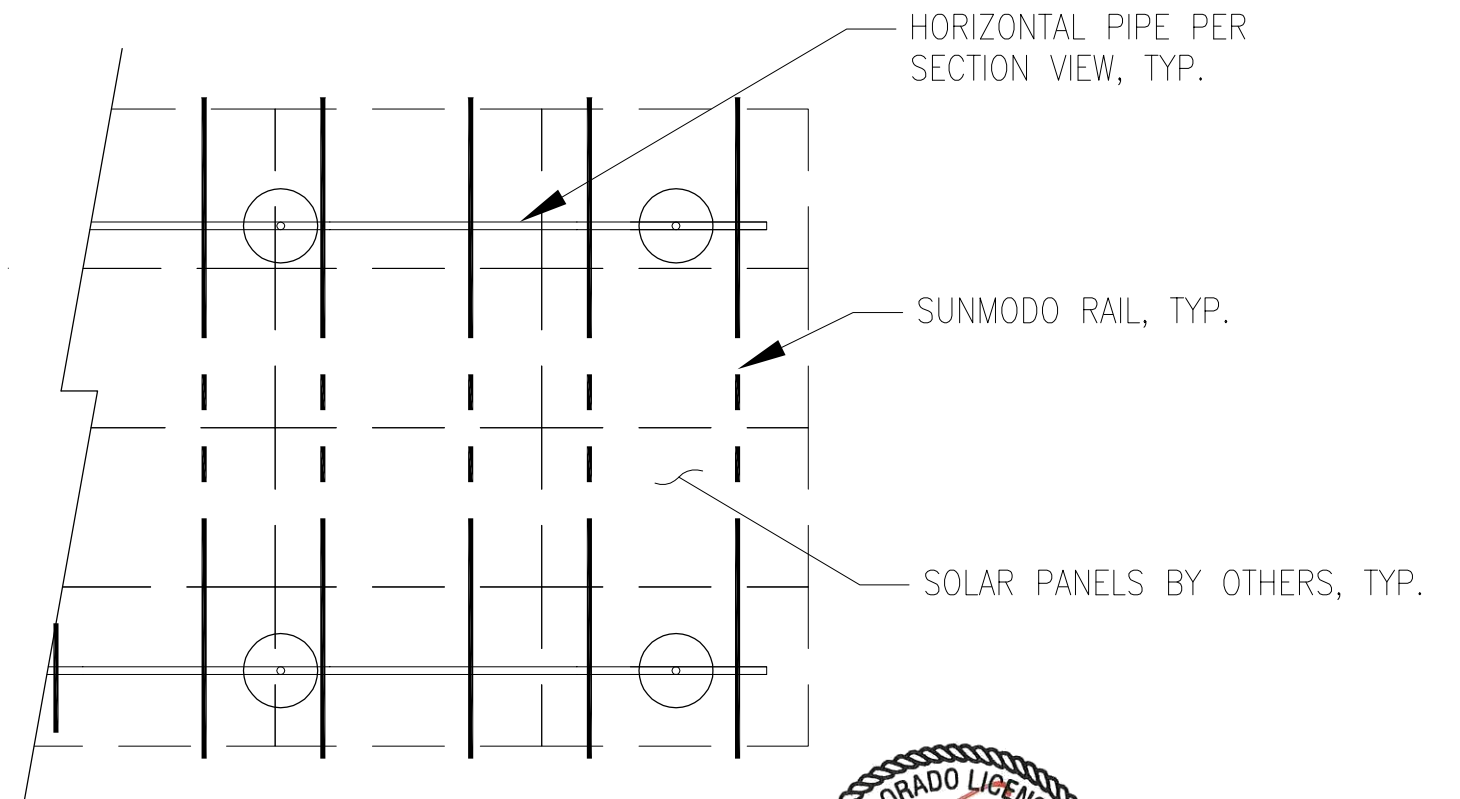
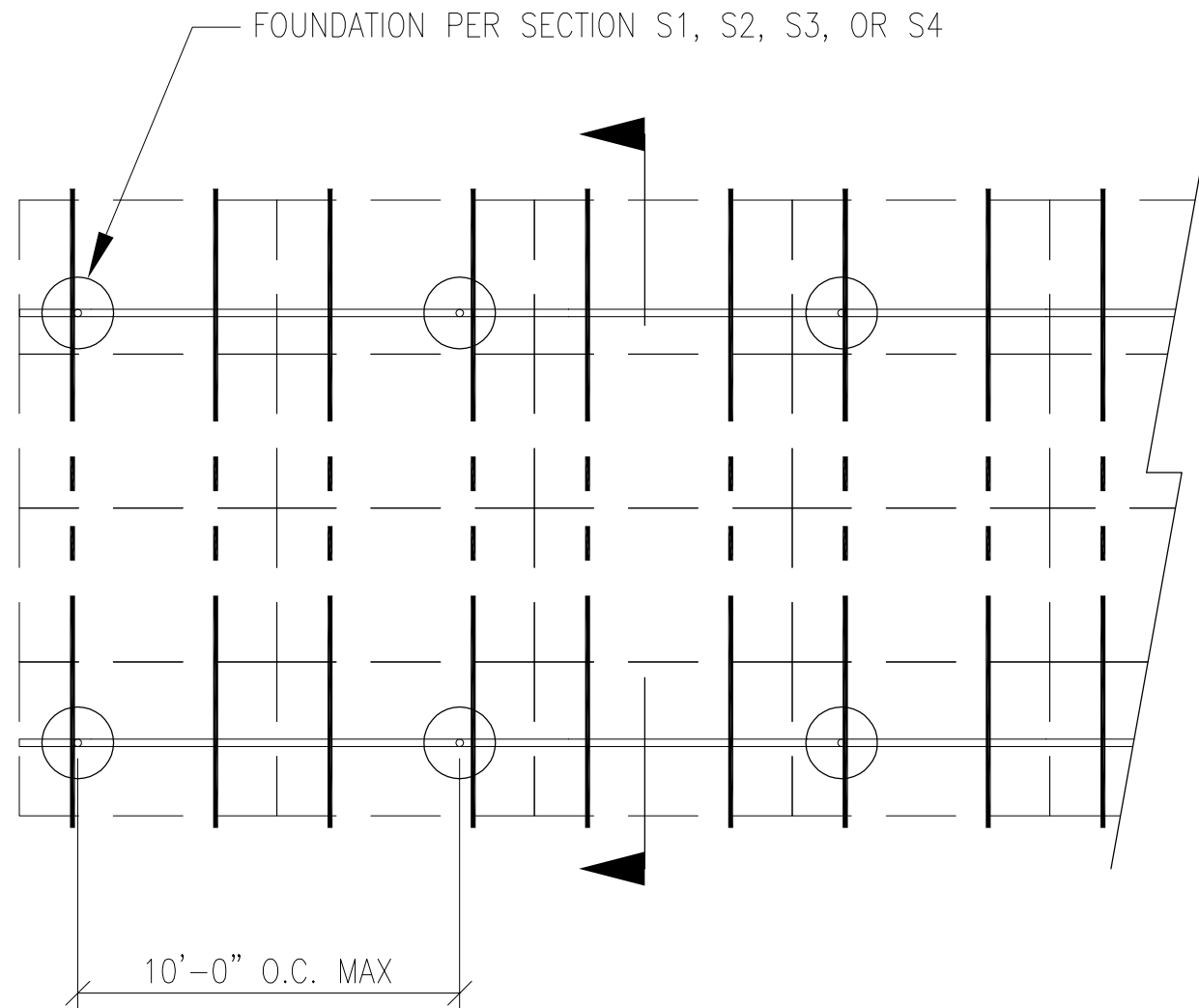

PV ARRAY PLAN

N.T.S.

PROJECT SUNMODO SUNTURF GROUND MOUNTS B3

SUBJECT DRILLED PIER OPTION

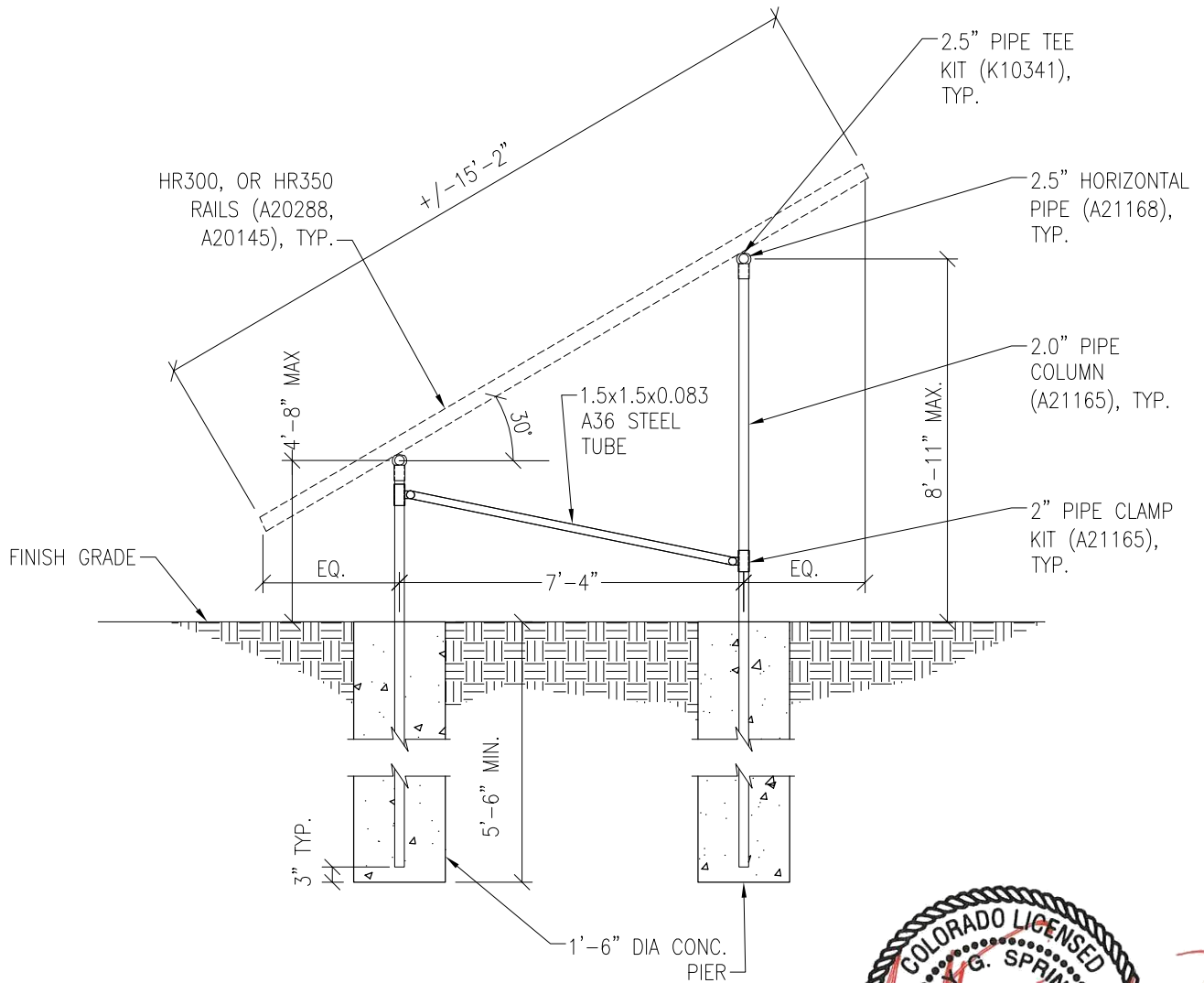

Vector Engineers requires that we review each site specific install and is not liable for installs at site specific locations we have not reviewed.

PV ARRAY SECTION

N.T.S.

S1

PROJECT SUNMODO SUNTURF GROUND MOUNTS B3

SUBJECT HELICAL PIER OPTION

NOTES:

1. For ground mount components see Section S1.
2. A minimum of (1) helical pier must be load-tested as follows:
 - 2.1. Safety factor for uplift = 1.5,
 - 2.2. Safety factor for lateral loads = 2.0
 - 2.3. Upward deflection limit = 1/2"
 - 2.4. Lateral deflection limit = 1"
 - 2.5. The load tests must be performed by an approved contractor.

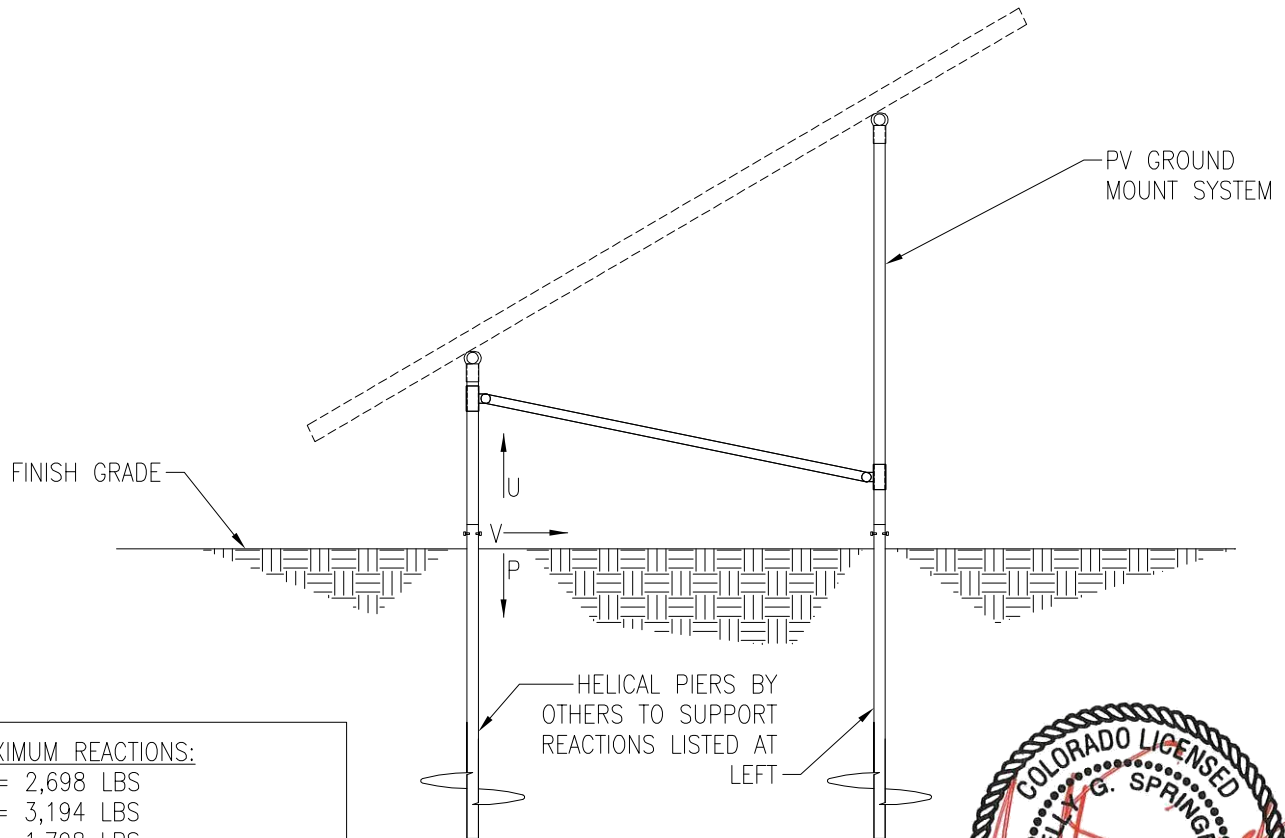

MAXIMUM REACTIONS:
 U = 2,698 LBS
 P = 3,194 LBS
 V = 1,798 LBS



Vector Engineers requires that we review each site specific install and is not liable for installs at site specific locations we have not reviewed.

PV ARRAY SECTION

N.T.S.

S2



JOB NO. U2716-097-191

PROJECT SUNMODO SUNTURF GROUND MOUNTS B3

SUBJECT GROUND SCREW OPTION

NOTES:

1. For ground mount components see Section S1.
2. A minimum of (1) ground screw must be load-tested as follows:
 - 2.1. Safety factor for uplift = 1.5,
 - 2.2. Safety factor for lateral loads = 2.0
 - 2.3. Upward deflection limit = 1/2"
 - 2.4. Lateral deflection limit = 1"
 - 2.5. The load tests must be performed by an approved contractor.

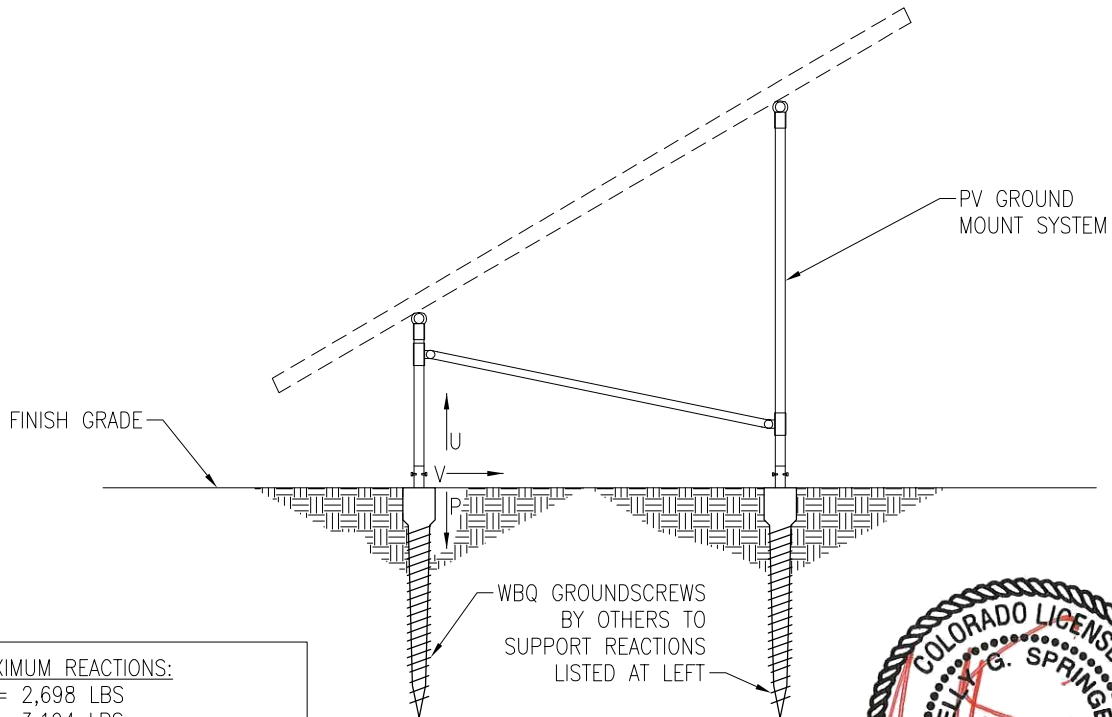

MAXIMUM REACTIONS:
 U = 2,698 LBS
 P = 3,194 LBS
 V = 1,798 LBS



Vector Engineers requires that we review each site specific install and is not liable for installs at site specific locations we have not reviewed.

PV ARRAY SECTION

N.T.S.

S3

651 W GALENA PARK BLVD. #101
 DRAPER, UTAH 84020

(801) 990-1775
 (801) 990-1776 FAX

WWW.VECTORSE.COM



JOB NO. U2716-097-191

DATE 12/20/2018

PROJECT SUNMODO SUNTURF GROUND MOUNTS B3

SUBJECT BALLASTED BLOCK OPTION DESIGNED STB CHECKED JSP

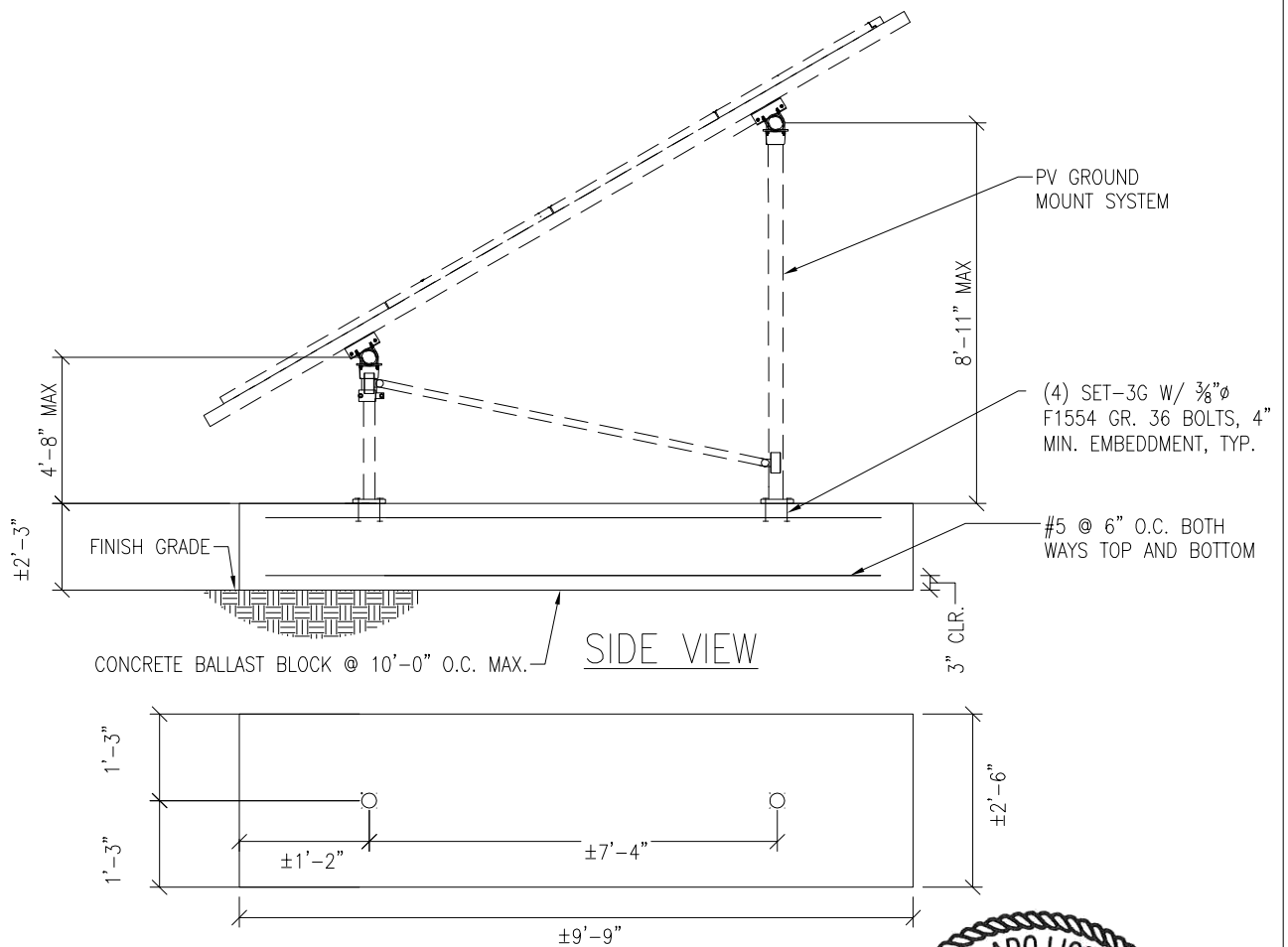

Vector Engineers requires that we review each site specific install and is not liable for installs at site specific locations we have not reviewed.

PV ARRAY SECTION

N.T.S.



651 W GALENA PARK BLVD. #101
 DRAPER, UTAH 84020

(801) 990-1775
 (801) 990-1776 FAX

WWW.VECTORSE.COM

PROJECT: B3 – Sunmodo Sunturf GM

SUBJECT: Dead Load

Design Weight:

Individual Panel Weight [lb]:	50.7
Panel Transverse Length (T5) [in]:	41.2
Panel Transverse Length (T5) [ft]:	3.4
Panel Longitudinal Length (L2) [in]:	81.4
Panel Longitudinal Length (L2) [ft]:	6.8
Individual Panel Area [ft ²]:	23.3
Individual Panel Weight [psf]:	2.2
# of Panels in Transverse Direction:	4
Approximate Transverse Length (T4) [ft]:	13.7
# of Panels in Longitudinal Direction:	12
Approximate Longitudinal Length (L1) [ft]:	81.4
Transverse Column Spacing (T1) [ft]:	7.1
Longitudinal Column Spacing (L3) [ft]:	10.0
# of Columns in Longitudinal Direction:	9
# of Columns in Transverse Direction:	2
Total Number of Columns:	18
Panel Slope from Horizontal (a) [°]:	30.0
Short Column Height (H1) [ft]:	4.5
Approximate Tall Column Height (H2) [ft]:	8.6
Transverse Brace between Columns :	Yes
Approximate Brace Length (B1) [ft]:	9.0
Weight of Columns [plf]:	3.7
Weight of Cross Pipe [plf]:	3.7
Weight of Brace [plf]:	3.7
Tributary Transverse Length per Column [ft]:	6.9
Tributary Longitudinal Length per Column [ft]:	10.0
Tributary Area per Column [ft ²]:	68.7
Rail Weight [plf]:	1.0
Transverse Rail Weight per Column [lb]:	27.5
Longitudinal Rail Weight per Column [lb]:	36.5
Tall Column Weight [lb]:	31.4
Panel Weight per Column [lb]:	149.5
Rail Weight per Column [lb]:	27.5
Cross Pipe Weight per Column [lb]:	36.5
Brace Weight per Column [lb]:	16.4
Total Weight per Column (1.0 D) [lb]:	261.3

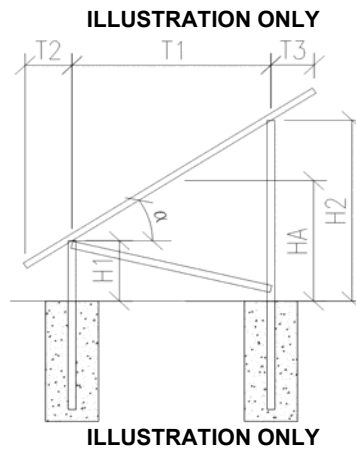
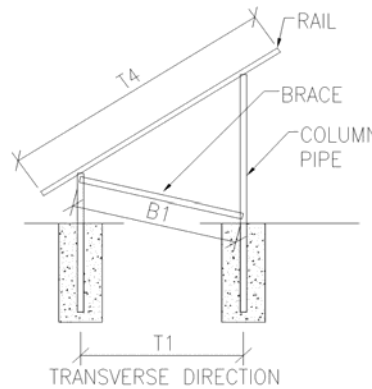
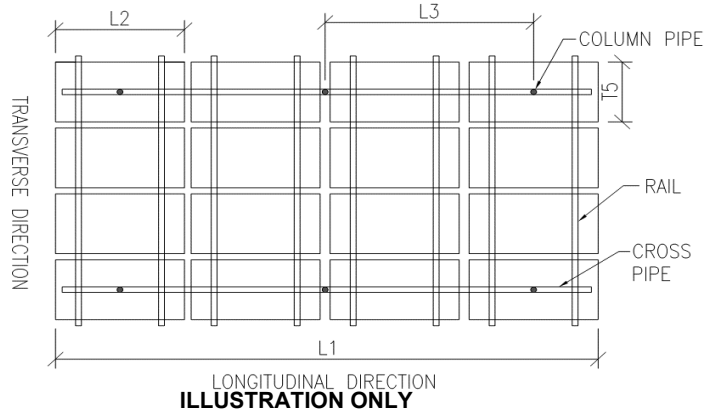

Assumptions:

- T2 = T3



JOB NO.: U2716-097-191

DESIGNED: STB

DATE: 07/25/19

PROJECT: B3 – Sunmodo Sunturf GM

SUBJECT: Snow Load

SNOW LOAD (S):

ASCE 7 Standard:	10	
Panel Slope from Horizontal [°]:	30.0	
Snow Ground Load, p_g [psf]:	30.0	(Section 7.2)
Terrain Category:	C	(Table 7-2)
Exposure of Roof:	Fully Exposed	(Table 7-2)
Exposure Factor, C_e :	0.9	(Table 7-2)
Thermal Factor, C_t :	1.2	(Table 7-3)
Risk Category:	I	(Table 1.5-1)
Importance Factor, I_s :	0.8	(Table 1.5-2)
Flat Roof Snow Load, p_f [psf]:	18	(Equation 7.3-1)
Minimum Roof Snow Load, p_m [psf]:	0	(Section 7.3.4)
Unobstructed Slippery Surface?	Yes	(Section 7.4)
Slope Factor Figure:	Figure 7-2c	(Section 7.4)
Roof Slope Factor, C_s :	0.727	(Figure 7-2)
Sloped Roof Snow Load, p_s [psf]:	13	(Equation 7.4-1)
Design Snow Load, S [psf]:	13	
Tributary Transverse Length [ft]:	5.9	
Tributary Longitudinal Length [ft]:	10	
Tributary Area per Column [ft ²]:	59.5	
Snow Load per Column (1.0 S) [lb]:	784.7	



PROJECT: B3 – Sunmodo Sunturf GM

SUBJECT: Wind Pressure

Design Wind Load:

ASCE 7 Standard:	10	
Basic Wind Speed, V [mph]:	105	
Risk Category:	I	
Exposure Category	C	(Section 26.7.3)
Velocity Pressure Exposure Coefficient, K_h :	0.85	(Table 27.3-1)
Topographic Factor, K_{ht} :	1.0	(Section 26.8.2)
Wind Directionality Factor, K_d :	0.85	(Table 26.6-1)
Internal Pressure Coefficient, GC_{pi} :	0.00	(Table 26.11-1)
Velocity Pressure, q_h [psf]:	20.4	(Equation 27.3-1)
Gust Effect Factor, G:	0.85	(Section 26.9.1)
Panel Slope [degrees]:	30.0	

Net Pressure Coefficients (C_N) per: (Figure 27.4-4)

Clear Wind Flow	C_{NW}	C_{NL}
Case 1 ($\gamma = 0^\circ$, Load Case A)	-1.80	-1.80
Case 2 ($\gamma = 0^\circ$, Load Case B)	-2.50	-0.50
Case 3 ($\gamma = 180^\circ$, Load Case A)	2.10	2.10
Case 4 ($\gamma = 180^\circ$, Load Case B)	2.60	1.00

Design Wind Pressures (p) [psf] per: (Equation 27.4-3)

Clear Wind Flow	$q_h GC_{NW}$	$q_h GC_{NL}$
Case 1 ($\gamma = 0^\circ$, Load Case A)	-31.2	-31.2
Case 2 ($\gamma = 0^\circ$, Load Case B)	-43.3	-8.7
Case 3 ($\gamma = 180^\circ$, Load Case A)	36.4	36.4
Case 4 ($\gamma = 180^\circ$, Load Case B)	45.1	17.3

Wind Pressure on Each Side of Panels [psf]

Clear Wind Flow	Short Col. Pressure	Long Col. Pressure
Case 1 ($\gamma = 0^\circ$, Load Case A)	-31.2	-31.2
Case 2 ($\gamma = 0^\circ$, Load Case B)	-8.7	-43.3
Case 3 ($\gamma = 180^\circ$, Load Case A)	36.4	36.4
Case 4 ($\gamma = 180^\circ$, Load Case B)	45.1	17.3



JOB NO.: U2716-097-191

PROJECT: B3 – Sunmodo Sunturf GM

SUBJECT: Open Building Wind Loads

Design Wind Load Per ASCE 7-10

$$p = q_h G C_n$$

Velocity Pressure Exposure Coefficient, K_z :	0.85	(Table 27.3-1)
Topographic Factor, K_{zt} :	1.0	(Section 26.8.2)
Wind Directionality Factor, K_d :	0.85	(Table 26.6-1)
Ultimate Wind Speed, V [mph]:	105	

Velocity Pressure, q_h [psf]:	20.4	(Equation 27.3-1)
Gust Effect Factor, G :	0.85	(Section 26.9.1)

$\gamma = 90^\circ$ or 270°

Force Coefficient, C_N :

Horizontal Distance from Winward Edge	Roof angle			Obstructed Wind Flow
	30	A	CN	
$\leq h$	30	A	-0.8	
		B	0.8	
$> h, \leq 2h$	30	A	-0.6	
		B	0.5	
$> 2h$	30	A	-0.3	
		B	0.3	

Design Wind Pressure, p [psf]:

	Roof angle			Obstructed Wind Flow
	30	A		
$\leq h$	30	A	-13.9	
		B	13.9	
$> h, \leq 2h$	30	A	-10.4	
		B	8.7	
$> 2h$	30	A	-5.2	
		B	5.2	



JOB NO.: U2716-097-191

DESIGNED: STB

Foundation Option 1: Drilled Concrete Pier



PROJECT: B3 - Sunturf Ground Mounts

DRILLED CONCRETE PIER DESIGN

Column Reactions:

Max. Shear, V [k]:	1.8	Max. Down, P _d [k]:	3.2
Max. Moment, M [k-ft]:	0.0	Max. Uplift, P _u [k]:	2.7

Pier Properties:

Pier Shape:	Round	Volume of Concrete [ft ³]:	10
Pier Diameter, b [ft]:	1.5	Volume of Concrete [yd ³]:	0.4
Top of Pier Elevation [ft]:	0.00	Weight of Concrete [k]:	1.5
Pier Depth, d [ft]:	5.5		

Soil Properties:

Allow. Bearing Pressure [psf]:	1,500	<u>Optional Parameters for Uplift:</u>	
1/3 increase for short term loads?	No		
Lateral Bearing, S [pcf]:	150	Skin Friction* [psf]:	250
Max. Lateral Bearing (opt'l) [psf]:		Top Length to Ignore [ft]:	0
Top Depth to Ignore [ft]:	0	1/3 increase for short term loads?	No
1/3 increase for short term loads?	No	Combine w/ Bearing:	No
1/2" deflection at t/o pier allowed:	Yes		

*per IBC Section 1810.3.3.1.4

Check Bearing:

Bearing Capacity [k]:	6.5
-----------------------	-----

Bearing capacity OK.

Check Uplift:

Uplift Capacity [k]:	7.8
----------------------	-----

Uplift capacity OK.

Check Lateral Bearing:

Top of Pier Constrained?:	No
Applied Lateral Force, P [lb]:	1,798
Point of Application, h [ft]:	0.0
S _{max} [psf]:	
S [psf]:	550
A = 2.34*P/(S _b):	5.10
Required Pier Depth, d _{reqd} [ft]:	5.10

IBC Section 1807.3.2.1

IBC Eq. 18-1

Result: **Lateral bearing capacity OK.**

Foundation Option 2: Helical Pier

The ground screws and helical piers must be tested to 1.5 times uplift and 2.0 times lateral reactions found in the table below.

Load (ASD)	Value (lbs)	Factor of Safety	Test Value (lbs)
UPLIFT	2698	1.5	4047
LATERAL	1798	2	3596

Foundation Option 3: Ground Screw

The ground screws and helical piers must be tested to 1.5 times uplift and 2.0 times lateral reactions found in the table below.

Load (ASD)	Value (lbs)	Factor of Safety	Test Value (lbs)
UPLIFT	2698	1.5	4047
LATERAL	1798	2	3596



JOB NO.: U2716-097-191

DESIGNED: STB

Foundation Option 4: Ballasted Block

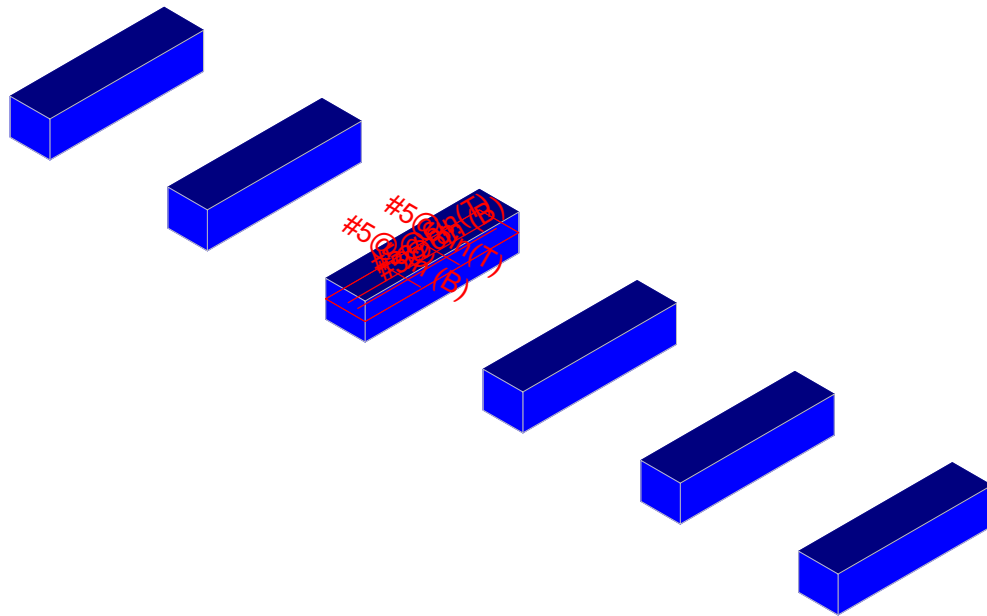

Results for LC 1, 1.0 D

Vector Structural Engineeri..	Ground Mount	SK - 2
STB		Apr 7, 2021 at 5:15 PM
U2716.097.191		Sunmodo Sunturf B3 GM v6 85x45...

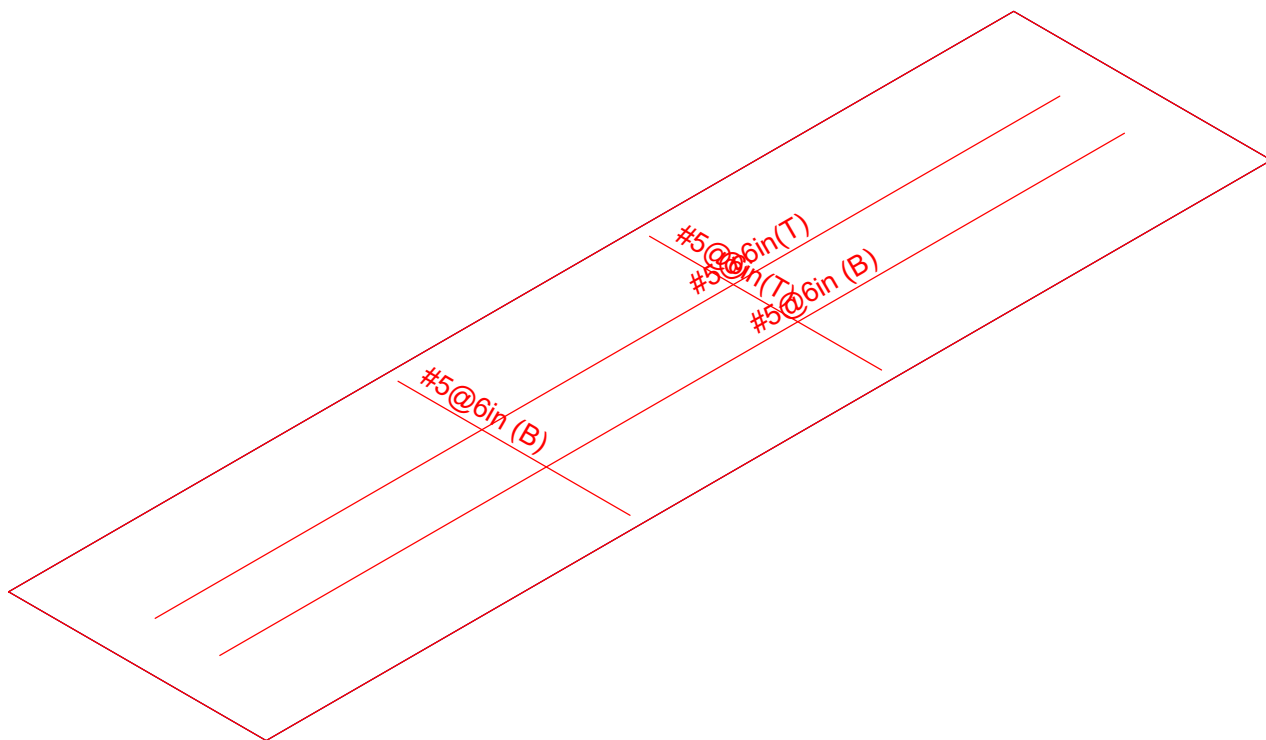

Results for LC 1, 1.0 D

Vector Structural Engineeri..	Ground Mount	SK - 1
STB		Apr 7, 2021 at 5:15 PM
U2716.097.191		Sunmodo Sunturf B3 GM v6 85x45...

(Global) Model Settings

Display Sections for Member Calcs	5
Max Internal Sections for Member Calcs	100
Mesh Size (in)	12
Max Iterations	10
Merge Tolerance (in)	.12
Solver	Sparse Accelerated
Coefficient of Friction	.3
No. of Shear Regions	4
Shear Region Spacing Increment (in)	4
Min 1 Bar Dia Spacing for Beams?	No
Optimize footings for OTM / Sliding?	Yes
Parame Beta Factor	.65
Pile Safety Factor	3
Concrete Stress Block	0
Concrete Rebar Set	Rectangular
Concrete Code	ASTM A615
HR Steel Pile Code	ACI 318-14
Wood Pile Code	AISC 14th (360-10): ASD AWC NDS-15: ASD

Concrete Properties

	Label	E [ksi]	G [ksi]	Nu	Therm (/...	Density[lb/ft^3]	fc[psi]	Lambda	Flex Stee...	Shear St...
1	Conc3000NW	3156	1372	.15	.6	145	3000	1	60000	60000
2	Conc3500NW	3409	1482	.15	.6	145	3500	1	60000	60000
3	Conc4000NW	3644	1584	.15	.6	145	4000	1	60000	60000
4	Conc3000LW	2085	907	.15	.6	109.999	3000	.75	60000	60000
5	Conc3500LW	2252	979	.15	.6	109.999	3500	.75	60000	60000
6	Conc4000LW	2408	1047	.15	.6	109.999	4000	.75	60000	60000
7	Conc2500NW	3156	1372	.15	.6	145	2500	1	60000	60000

General Design Parameters

	Label	Max Bending Chk	Max Shear Chk	Top Cover[in]	Bottom Cover[in]
1	Typical	1	1	3	3

Slab Rebar Parameters

	Label	Top Bar	Bottom Bar	Max Top Bar Sp...	Min Top Bar Sp...	Max Bot Bar Sp...	Min Bot Bar Sp...	Spacing Incr...	Rebar Options
1	Typical	#5	#5	6	6	6	6	1	Optimize

Soil Definitions

	Label	Subgrade Modulus[lb/ft^3]	Allowable Bearing[psf]	Depth Properties	Default?
1	Default	1e+5	1500	None	Yes

Point Loads and Moments (Cat 1 : DL)

	Label	Direction	Magnitude[lb,lb-ft]
1	R3D_N1	X	-25.326
2	R3D_N1	Y	279.368
3	R3D_N2	X	-8.085
4	R3D_N2	Y	255.632
5	R3D_N132_1	X	1.029
6	R3D_N132_1	Y	282.676
7	R3D_N133_1	X	-1.301
8	R3D_N133_1	Y	320.802

Point Loads and Moments (Cat 1 : DL) (Continued)

	Label	Direction	Magnitude[lb,lb-ft]
9	R3D_N109_1	X	-1.047
10	R3D_N109_1	Y	282.697
11	R3D_N110A_1	X	1.296
12	R3D_N110A_1	Y	320.807
13	R3D_N121_1	Y	302.944
14	R3D_N122_1	Y	311.02
15	R3D_N133B_1	Y	302.905
16	R3D_N134B_1	Y	311.019
17	R3D_N137C_1	X	25.356
18	R3D_N137C_1	Y	279.359
19	R3D_N138B_1	X	8.093
20	R3D_N138B_1	Y	255.636

Point Loads and Moments (Cat 6 : RLL)

	Label	Direction	Magnitude[lb,lb-ft]
1	R3D_N1	X	-75.081
2	R3D_N1	Y	723.238
3	R3D_N2	X	-25.31
4	R3D_N2	Y	716.975
5	R3D_N132_1	X	3.26
6	R3D_N132_1	Y	753.685
7	R3D_N133_1	X	-4.157
8	R3D_N133_1	Y	918.575
9	R3D_N109_1	X	-3.314
10	R3D_N109_1	Y	753.765
11	R3D_N110A_1	X	4.143
12	R3D_N110A_1	Y	918.594
13	R3D_N121_1	X	2.062
14	R3D_N121_1	Y	817.521
15	R3D_N122_1	X	2.933
16	R3D_N122_1	Y	887.361
17	R3D_N133B_1	X	-2.098
18	R3D_N133B_1	Y	817.405
19	R3D_N134B_1	X	-2.941
20	R3D_N134B_1	Y	887.361
21	R3D_N137C_1	X	75.169
22	R3D_N137C_1	Y	723.198
23	R3D_N138B_1	X	25.333
24	R3D_N138B_1	Y	716.983

Point Loads and Moments (Cat 16 : OL1)

	Label	Direction	Magnitude[lb,lb-ft]
1	R3D_N1	X	198.584
2	R3D_N1	Y	-3485.017
3	R3D_N1	Z	1930.006
4	R3D_N2	X	56.988
5	R3D_N2	Y	1.926
6	R3D_N2	Z	-68.85
7	R3D_N132_1	X	-7.47
8	R3D_N132_1	Y	-4093.913
9	R3D_N132_1	Z	2567.588
10	R3D_N133_1	Y	109.093
11	R3D_N133_1	Z	-80.585
12	R3D_N109_1	X	7.577
13	R3D_N109_1	Y	-4094.13
14	R3D_N109_1	Z	2567.454

Point Loads and Moments (Cat 16 : OL1) (Continued)

	Label	Direction	Magnitude[lb.-ft]
15	R3D_N110A_1	Y	109.02
16	R3D_N110A_1	Z	-80.583
17	R3D_N121_1	X	-7.456
18	R3D_N121_1	Y	-4118.639
19	R3D_N121_1	Z	2407.816
20	R3D_N122_1	Y	24.965
21	R3D_N122_1	Z	-80.508
22	R3D_N133B_1	X	7.523
23	R3D_N133B_1	Y	-4118.269
24	R3D_N133B_1	Z	2407.735
25	R3D_N134B_1	Y	24.897
26	R3D_N134B_1	Z	-80.507
27	R3D_N137C_1	X	-198.755
28	R3D_N137C_1	Y	-3484.939
29	R3D_N137C_1	Z	1929.954
30	R3D_N138B_1	X	-57.085
31	R3D_N138B_1	Y	1.897
32	R3D_N138B_1	Z	-68.849

Point Loads and Moments (Cat 17 : OL2)

	Label	Direction	Magnitude[lb.-ft]
1	R3D_N1	X	269.969
2	R3D_N1	Y	-4075.669
3	R3D_N1	Z	1615.32
4	R3D_N2	X	5.587
5	R3D_N2	Y	1063.448
6	R3D_N2	Z	-57.567
7	R3D_N132_1	X	-9.855
8	R3D_N132_1	Y	-4717.642
9	R3D_N132_1	Z	2155.738
10	R3D_N133_1	X	-12.986
11	R3D_N133_1	Y	1486.171
12	R3D_N133_1	Z	-67.693
13	R3D_N109_1	X	9.991
14	R3D_N109_1	Y	-4717.989
15	R3D_N109_1	Z	2155.626
16	R3D_N110A_1	X	13.025
17	R3D_N110A_1	Y	1486.007
18	R3D_N110A_1	Z	-67.691
19	R3D_N121_1	X	-9.672
20	R3D_N121_1	Y	-4804.006
21	R3D_N121_1	Z	2015.228
22	R3D_N122_1	X	6.082
23	R3D_N122_1	Y	1360.136
24	R3D_N122_1	Z	-67.417
25	R3D_N133B_1	X	9.757
26	R3D_N133B_1	Y	-4803.53
27	R3D_N133B_1	Z	2015.137
28	R3D_N134B_1	X	-6.046
29	R3D_N134B_1	Y	1360.019
30	R3D_N134B_1	Z	-67.416
31	R3D_N137C_1	X	-270.189
32	R3D_N137C_1	Y	-4075.567
33	R3D_N137C_1	Z	1615.289
34	R3D_N138B_1	X	-5.662
35	R3D_N138B_1	Y	1063.417

Point Loads and Moments (Cat 17 : OL2) (Continued)

	Label	Direction	Magnitude[lb,lb-ft]
36	R3D_N138B_1	Z	-57.566

Point Loads and Moments (Cat 18 : OL3)

	Label	Direction	Magnitude[lb,lb-ft]
1	R3D_N1	X	-231.681
2	R3D_N1	Y	4065.853
3	R3D_N1	Z	-2251.674
4	R3D_N2	X	-66.486
5	R3D_N2	Y	-2.247
6	R3D_N2	Z	80.325
7	R3D_N132_1	X	8.716
8	R3D_N132_1	Y	4776.232
9	R3D_N132_1	Z	-2995.519
10	R3D_N133_1	Y	-127.275
11	R3D_N133_1	Z	94.016
12	R3D_N109_1	X	-8.84
13	R3D_N109_1	Y	4776.486
14	R3D_N109_1	Z	-2995.364
15	R3D_N110A_1	Y	-127.19
16	R3D_N110A_1	Z	94.013
17	R3D_N121_1	X	8.699
18	R3D_N121_1	Y	4805.079
19	R3D_N121_1	Z	-2809.119
20	R3D_N122_1	Y	-29.126
21	R3D_N122_1	Z	93.926
22	R3D_N133B_1	X	-8.777
23	R3D_N133B_1	Y	4804.647
24	R3D_N133B_1	Z	-2809.024
25	R3D_N134B_1	Y	-29.046
26	R3D_N134B_1	Z	93.925
27	R3D_N137C_1	X	231.88
28	R3D_N137C_1	Y	4065.762
29	R3D_N137C_1	Z	-2251.613
30	R3D_N138B_1	X	66.599
31	R3D_N138B_1	Y	-2.213
32	R3D_N138B_1	Z	80.324

Point Loads and Moments (Cat 19 : OL4)

	Label	Direction	Magnitude[lb,lb-ft]
1	R3D_N1	X	-114.635
2	R3D_N1	Y	2543.763
3	R3D_N1	Z	-1924.396
4	R3D_N2	X	-90.656
5	R3D_N2	Y	851.231
6	R3D_N2	Z	68.695
7	R3D_N132_1	X	4.555
8	R3D_N132_1	Y	3044.546
9	R3D_N132_1	Z	-2554.667
10	R3D_N133_1	X	-11.657
11	R3D_N133_1	Y	1011.955
12	R3D_N133_1	Z	80.152
13	R3D_N109_1	X	-4.622
14	R3D_N109_1	Y	3044.629
15	R3D_N109_1	Z	-2554.534
16	R3D_N110A_1	X	11.582
17	R3D_N110A_1	Y	1011.944

Point Loads and Moments (Cat 19 : OL4) (Continued)

	Label	Direction	Magnitude[lb,lb-ft]
18	R3D_N110A_1	Z	80.15
19	R3D_N121_1	X	4.678
20	R3D_N121_1	Y	3016.436
21	R3D_N121_1	Z	-2400.815
22	R3D_N122_1	X	3.826
23	R3D_N122_1	Y	1051.145
24	R3D_N122_1	Z	80.245
25	R3D_N133B_1	X	-4.72
26	R3D_N133B_1	Y	3016.201
27	R3D_N133B_1	Z	-2400.752
28	R3D_N134B_1	X	-3.853
29	R3D_N134B_1	Y	1051.166
30	R3D_N134B_1	Z	80.244
31	R3D_N137C_1	X	114.744
32	R3D_N137C_1	Y	2543.715
33	R3D_N137C_1	Z	-1924.335
34	R3D_N138B_1	X	90.758
35	R3D_N138B_1	Y	851.255
36	R3D_N138B_1	Z	68.694

Point Loads and Moments (Cat 20 : OL5)

	Label	Direction	Magnitude[lb,lb-ft]
1	R3D_N1	X	-59.857
2	R3D_N1	Y	1502.083
3	R3D_N1	Z	-847.159
4	R3D_N2	X	-19.633
5	R3D_N2	Y	-7.873
6	R3D_N2	Z	26.755
7	R3D_N132_1	X	4.921
8	R3D_N132_1	Y	668.487
9	R3D_N132_1	Z	-428.189
10	R3D_N133_1	X	-1.003
11	R3D_N133_1	Y	-16.939
12	R3D_N133_1	Z	13.524
13	R3D_N109_1	X	5.311
14	R3D_N109_1	Y	1194.956
15	R3D_N109_1	Z	-752.835
16	R3D_N110A_1	X	14.576
17	R3D_N110A_1	Y	-31.005
18	R3D_N110A_1	Z	23.339
19	R3D_N121_1	X	3.758
20	R3D_N121_1	Y	666.018
21	R3D_N121_1	Z	-386.312
22	R3D_N122_1	X	-2.743
23	R3D_N122_1	Y	2.078
24	R3D_N122_1	Z	15.595
25	R3D_N133B_1	X	1.408
26	R3D_N133B_1	Y	692.036
27	R3D_N133B_1	Z	-404.512
28	R3D_N134B_1	Y	-5.3
29	R3D_N134B_1	Z	13.865
30	R3D_N137C_1	X	44.595
31	R3D_N137C_1	Y	591.801
32	R3D_N137C_1	Z	-321.102
33	R3D_N138B_1	X	9.124
34	R3D_N138B_1	Y	1.193



Point Loads and Moments (Cat 20 : OL5) (Continued)

	Label	Direction	Magnitude[lb.-ft]
35	R3D_N138B_1	Z	11.485

Point Loads and Moments (Cat 21 : OL6)

	Label	Direction	Magnitude[lb.-ft]
1	R3D_N1	X	52.09
2	R3D_N1	Y	-1460.713
3	R3D_N1	Z	827.352
4	R3D_N2	X	14.169
5	R3D_N2	Y	7.858
6	R3D_N2	Z	-25.607
7	R3D_N132_1	X	-3.888
8	R3D_N132_1	Y	-672.443
9	R3D_N132_1	Z	428.274
10	R3D_N133_1	X	1.504
11	R3D_N133_1	Y	16.993
12	R3D_N133_1	Z	-13.504
13	R3D_N109_1	X	-3.297
14	R3D_N109_1	Y	-1031.401
15	R3D_N109_1	Z	652.839
16	R3D_N110A_1	X	-10.382
17	R3D_N110A_1	Y	24.114
18	R3D_N110A_1	Z	-21.223
19	R3D_N121_1	X	-3.014
20	R3D_N121_1	Y	-668.996
21	R3D_N121_1	Z	388.392
22	R3D_N122_1	X	2.936
23	R3D_N122_1	Z	-15.057
24	R3D_N133B_1	Y	-690.842
25	R3D_N133B_1	Z	403.988
26	R3D_N134B_1	Y	5.133
27	R3D_N134B_1	Z	-13.757
28	R3D_N137C_1	X	-41.32
29	R3D_N137C_1	Y	-587.896
30	R3D_N137C_1	Z	321.076
31	R3D_N138B_1	X	-9.005
32	R3D_N138B_1	Z	-11.479

Slabs

	Label	Thickness [in]	Material	Local Axis Angle ...	Analysis Offset [in]	Passive Pressur...	Soil Overburden [psf]
1	S1	27	Conc2500NW	0	0	0	0
2	S2	27	Conc2500NW	0	0	0	0
3	S3	27	Conc2500NW	0	0	0	0
4	S4	27	Conc2500NW	0	0	0	0
5	S5	27	Conc2500NW	0	0	0	0
6	S6	27	Conc2500NW	0	0	0	0

Load Combinations

	Label	Solve	Service A...	SF	Cat..Fa...	Cat..Fa...	Cat..Fa...	Cat..Fa...	Cat..Fa...	Cat..Fa...	Cat..Fa...	Cat..Fa...	Cat..Fa...	C...	F...	C...	F...
1	1.0 D	Yes	Yes	1.5	DL	1											
2	1.0 D + 1....	Yes	Yes	1.5	DL	1	RLL	1									
3	1.0 D + 0....	Yes	Yes	1.5	DL	1	RLL		OL1	.6							
4	1.0 D + 0....	Yes	Yes	1.5	DL	1	RLL		OL2	.6							
5	1.0 D + 0....	Yes	Yes	1.5	DL	1	RLL		OL3	.6							
6	1.0 D + 0....	Yes	Yes	1.5	DL	1	RLL		OL4	.6							
7	1.0 D + 0....	Yes	Yes	1.5	DL	1	RLL		OL5	.6							



Load Combinations (Continued)

Label	Solve	Service	A...	SF	Cat.	Fa...	Cat.	Fa...	Cat.	Fa...	Cat.	Fa...	Cat.	Fa...	C...	F...	C...	F...
8	1.0D+0...	Yes	Yes	1.5	DL	1	RLL	.75	OL6	.45								
9	1.0D+0...	Yes	Yes	1.5	DL	1	RLL	.75	OL1	.45								
10	1.0D+0...	Yes	Yes	1.5	DL	1	RLL	.75	OL2	.45								
11	1.0D+0...	Yes	Yes	1.5	DL	1	RLL	.75	OL3	.45								
12	1.0D+0...	Yes	Yes	1.5	DL	1	RLL	.75	OL4	.45								
13	1.0D+0...	Yes	Yes	1.5	DL	1	RLL	.75	OL5	.45								
14	1.0D+0...	Yes	Yes	1.5	DL	1	RLL	.75	OL6	.45								
15	0.9D+0...	Yes	Yes		DL	.9	RLL		OL1	.6								
16	0.9D+0...	Yes	Yes		DL	.9	RLL		OL2	.6								
17	0.9D+0...	Yes	Yes		DL	.9	RLL		OL3	.6								
18	0.9D+0...	Yes	Yes		DL	.9	RLL		OL4	.6								
19	0.9D+0...	Yes	Yes		DL	.9	RLL		OL5	.6								
20	0.9D+0...	Yes	Yes		DL	.9	RLL		OL6	.6								
21																		
22	1.4D	Yes			DL	1.4												
23	1.2D+1.6SL	Yes			DL	1.2	RLL	1.6										
24	1.2D+1.6S...	Yes			DL	1.2	RLL	1.6	OL1	.5								
25	1.2D+1.6S...	Yes			DL	1.2	RLL	1.6	OL2	.5								
26	1.2D+1.6S...	Yes			DL	1.2	RLL	1.6	OL3	.5								
27	1.2D+1.6S...	Yes			DL	1.2	RLL	1.6	OL4	.5								
28	1.2D+1.6S...	Yes			DL	1.2	RLL	1.6	OL5	.5								
29	1.2D+1.6S...	Yes			DL	1.2	RLL	1.6	OL6	.5								
30	1.2D+1.0...	Yes			DL	1.2			OL1	1								
31	1.2D-1.0Wx	Yes			DL	1.2			OL2	1								
32	1.2D+1.0...	Yes			DL	1.2			OL3	1								
33	1.2D-1.0Wz	Yes			DL	1.2			OL4	1								
34	1.2D+1.0...	Yes			DL	1.2			OL5	1								
35	1.2D-1.0...	Yes			DL	1.2			OL6	1								
36	1.0D+1.0...	Yes			DL	1			OL1	1								
37	1.0D-1.0Wx	Yes			DL	1			OL2	1								
38	1.0D+1.0...	Yes			DL	1			OL3	1								
39	1.0D-1.0Wz	Yes			DL	1			OL4	1								
40	1.0D+1.0...	Yes			DL	1			OL5	1								
41	1.0D-1.0...	Yes			DL	1			OL6	1								

Design Strips

	Label	Rebar Angle from Pl...	No. of Design Cuts	Design Rule
1	DS1	0	50	Typical
2	DS2	90	50	Typical

Load Categories

	Category	Point Loads	Line Loads	Area Loads
1	DL	20		
2	RLL	24		
3	OL1	32		
4	OL2	36		
5	OL3	32		
6	OL4	36		
7	OL5	35		
8	OL6	32		

Strip Reinforcing

	Label	UC Top	LC	Top Bars	Governing ...	UC Bot	LC	Bot B...	Gover...	UC Shear	LC	Governing De...
1	DS1	.019	26	#5@6in	DS1-X25	.036	37	#5@6in	DS1-...	.049	37	DS1-X45
2	DS2	.002	36	#5@6in	DS2-X26	.003	26	#5@6in	DS2-...	.007	26	DS2-X46



Company : Vector Structural Engineering
 Designer : STB
 Job Number : U2716.097.191
 Model Name : Ground Mount

Apr 7, 2021
 5:15 PM
 Checked By: JSP

Slab Overturning Safety Factors (By Combination)

LC	Slab	Angle[deg]	Mo-xx[lb-ft]	Ms-xx[lb-ft]	Mo-zz[lb-ft]	Ms-zz[lb-ft]	Ms-xx/Mo-xx	Ms-zz/Mo-zz
1	1	S1	0	0	41311.187	0	10684.372	9.999+
2	1	S2	0	0	41874.774	0	10694.266	9.999+
3	1	S3	0	0	41816.072	0	10707.902	9.999+
4	1	S4	0	0	41816.019	0	10707.852	9.999+
5	1	S5	0	0	41874.703	0	10695.407	9.999+
6	1	S6	0	0	41311.209	0	10533.929	9.999+
7	2	S1	0	0	48369.268	0	12710.521	9.999+
8	2	S2	0	0	50701.573	0	12782.848	9.999+
9	2	S3	0	0	50454.486	0	12827.767	9.999+
10	2	S4	0	0	50454.28	0	12850.145	9.999+
11	2	S5	0	0	50701.24	0	12787.751	9.999+
12	2	S6	0	0	48369.305	0	12108.025	9.999+
13	3	S1	0	20284.842	41440.685	2957.341	10684.372	2.043
14	3	S2	0	24161.078	41545.017	2999.061	10694.266	1.72
15	3	S3	0	24129.502	41705.703	3080.322	10707.902	1.728
16	3	S4	0	24127.554	41705.367	3080.186	10707.852	1.729
17	3	S5	0	24160.097	41544.833	2998.701	10694.181	1.72
18	3	S6	0	20284.397	41440.609	2957.665	10684.45	2.043
19	4	S1	0	22144.502	41440.685	2631.167	10684.372	1.871
20	4	S2	0	25840.293	41545.017	2455.058	10694.266	1.608
21	4	S3	0	26177.922	41705.703	2587.748	10707.902	1.593
22	4	S4	0	26175.455	41705.367	2587.643	10707.852	1.593
23	4	S5	0	25838.556	41544.833	2454.438	10694.181	1.608
24	4	S6	0	22143.964	41440.609	2631.512	10684.45	1.871
25	5	S1	0	0	41417.675	0	14134.603	9.999+
26	5	S2	0	989.5	41874.774	0	14193.17	9.999+
27	5	S3	0	211.711	41816.072	0	14278.123	9.999+
28	5	S4	0	211.497	41816.019	0	14301.401	9.999+
29	5	S5	0	990.332	41874.703	0	14170.36	9.999+
30	5	S6	0	0	41417.883	0	13178.643	9.999+
31	6	S1	0	0	45097.645	0	13507.761	9.999+
32	6	S2	0	0	46029.329	0	13727.299	9.999+
33	6	S3	0	0	46359.018	0	13747.108	9.999+
34	6	S4	0	0	46358.979	0	13769.951	9.999+
35	6	S5	0	0	46029.074	0	13747.371	9.999+
36	6	S6	0	0	45097.833	0	12802.729	9.999+
37	7	S1	0	21.532	41311.187	0	11912.341	9.999+
38	7	S2	0	248.281	41874.774	0	11540.381	9.999+
39	7	S3	0	0	41825.816	0	11207.603	9.999+
40	7	S4	0	35.644	41816.019	0	11221.002	9.999+
41	7	S5	0	145.672	41874.703	0	11178.778	9.999+
42	7	S6	0	0	41343.219	0	10906.154	9.999+
43	8	S1	0	8526.507	41440.685	1179.09	10684.372	4.86
44	8	S2	0	6095.962	41545.017	773.931	10695.388	6.815
45	8	S3	0	3915.889	41705.703	501.853	10707.902	9.999+
46	8	S4	0	4046.522	41705.367	514.282	10707.852	9.999+
47	8	S5	0	3977.513	41544.833	494.807	10694.181	9.999+
48	8	S6	0	3416.234	41440.609	508.861	10684.45	9.999+
49	9	S1	0	15213.632	46678.706	2218.005	12203.984	3.068
50	9	S2	0	18120.809	47154.062	2249.296	12260.703	2.602
51	9	S3	0	18097.127	47693.87	2310.241	12314.658	2.635
52	9	S4	0	18095.665	47692.79	2310.139	12314.572	2.636
53	9	S5	0	18120.073	47153.354	2249.026	12260.411	2.602
54	9	S6	0	15213.298	46678.38	2218.249	12204.217	3.068
55	10	S1	0	16608.377	46678.706	1973.375	12203.984	2.811
56	10	S2	0	19380.22	47154.062	1841.294	12260.703	2.433
57	10	S3	0	19633.442	47693.87	1940.811	12314.658	2.429



Company : Vector Structural Engineering
 Designer : STB
 Job Number : U2716.097.191
 Model Name : Ground Mount

Apr 7, 2021
 5:15 PM
 Checked By: JSP

Slab Overturning Safety Factors (By Combination) (Continued)

LC	Slab	Angle[deg]	Mo-xx[lb-ft]	Ms-xx[lb-ft]	Mo-zz[lb-ft]	Ms-zz[lb-ft]	Ms-xx/Mo-xx	Ms-zz/Mo-zz	
58	10	S4	0	19631.591	47692.79	1940.732	12314.572	2.429	6.345
59	10	S5	0	19378.917	47153.354	1840.828	12260.411	2.433	6.66
60	10	S6	0	16607.973	46678.38	1973.634	12204.217	2.811	6.184
61	11	S1	0	0	46684.614	0	14791.657	9.999+	9.999+
62	11	S2	0	742.125	48494.873	0	14884.881	9.999+	9.999+
63	11	S3	0	158.783	48294.882	0	14975.467	9.999+	9.999+
64	11	S4	0	158.623	48294.715	0	15009.734	9.999+	9.999+
65	11	S5	0	742.749	48494.606	0	14870.88	9.999+	9.999+
66	11	S6	0	0	46684.786	0	13698.037	9.999+	9.999+
67	12	S1	0	0	49444.592	0	14321.526	9.999+	9.999+
68	12	S2	0	0	51610.79	0	14535.478	9.999+	9.999+
69	12	S3	0	0	51702.092	0	14577.206	9.999+	9.999+
70	12	S4	0	0	51701.935	0	14611.146	9.999+	9.999+
71	12	S5	0	0	51610.384	0	14553.638	9.999+	9.999+
72	12	S6	0	0	49444.749	0	13416.101	9.999+	9.999+
73	13	S1	0	16.149	46604.748	0	13124.961	9.999+	9.999+
74	13	S2	0	186.211	48494.873	0	12895.289	9.999+	9.999+
75	13	S3	0	0	48302.191	0	12672.577	9.999+	9.999+
76	13	S4	0	26.733	48294.715	0	12699.435	9.999+	9.999+
77	13	S5	0	109.254	48494.606	0	12627.194	9.999+	9.999+
78	13	S6	0	0	46628.789	0	11993.67	9.999+	9.999+
79	14	S1	0	6394.88	46678.706	884.318	12203.984	7.299	9.999+
80	14	S2	0	4571.971	47154.062	580.448	12264.624	9.999+	9.999+
81	14	S3	0	2936.916	47693.87	376.231	12297.801	9.999+	9.999+
82	14	S4	0	3034.892	47692.79	385.711	12297.567	9.999+	9.999+
83	14	S5	0	2983.135	47153.354	371.105	12260.411	9.999+	9.999+
84	14	S6	0	2562.175	46678.38	381.645	12204.217	9.999+	9.999+
85	15	S1	0	20284.842	37296.616	2957.341	9615.935	1.839	3.252
86	15	S2	0	24161.078	37390.515	2999.061	9624.839	1.548	3.209
87	15	S3	0	24129.502	37535.132	3080.322	9637.111	1.556	3.129
88	15	S4	0	24127.554	37534.83	3080.186	9637.066	1.556	3.129
89	15	S5	0	24160.097	37390.349	2998.701	9624.763	1.548	3.21
90	15	S6	0	20284.397	37296.548	2957.665	9616.005	1.839	3.251
91	16	S1	0	22144.502	37296.616	2631.167	9615.935	1.684	3.655
92	16	S2	0	25840.293	37390.515	2455.058	9624.839	1.447	3.92
93	16	S3	0	26177.922	37535.132	2587.748	9637.111	1.434	3.724
94	16	S4	0	26175.455	37534.83	2587.643	9637.066	1.434	3.724
95	16	S5	0	25838.556	37390.349	2454.438	9624.763	1.447	3.921
96	16	S6	0	22143.964	37296.548	2631.512	9616.005	1.684	3.654
97	17	S1	0	0	37286.556	0	13066.166	9.999+	9.999+
98	17	S2	0	989.5	37687.296	0	13123.744	9.999+	9.999+
99	17	S3	0	211.711	37634.465	0	13207.333	9.999+	9.999+
100	17	S4	0	211.497	37634.417	0	13230.616	9.999+	9.999+
101	17	S5	0	990.332	37687.233	0	13100.819	9.999+	9.999+
102	17	S6	0	0	37286.762	0	12125.251	9.999+	9.999+
103	18	S1	0	0	40966.527	0	12439.324	9.999+	9.999+
104	18	S2	0	0	41841.852	0	12657.873	9.999+	9.999+
105	18	S3	0	0	42177.411	0	12676.318	9.999+	9.999+
106	18	S4	0	0	42177.377	0	12699.166	9.999+	9.999+
107	18	S5	0	0	41841.604	0	12677.83	9.999+	9.999+
108	18	S6	0	0	40966.712	0	11749.336	9.999+	9.999+
109	19	S1	0	21.532	37180.068	0	10843.904	9.999+	9.999+
110	19	S2	0	248.281	37687.296	0	10470.955	9.999+	9.999+
111	19	S3	0	0	37644.209	0	10136.813	9.999+	9.999+
112	19	S4	0	35.644	37634.417	0	10150.217	9.999+	9.999+
113	19	S5	0	145.672	37687.233	0	10109.238	9.999+	9.999+
114	19	S6	0	0	37212.098	0	9852.761	9.999+	9.999+



Slab Overturning Safety Factors (By Combination) (Continued)

	LC	Slab	Angle[deg]	Mo-xx[lb-ft]	Ms-xx[lb-ft]	Mo-zz[lb-ft]	Ms-zz[lb-ft]	Ms-xx/Mo-xx	Ms-zz/Mo-zz
115	20	S1	0	8526.507	37296.616	1179.09	9615.935	4.374	8.155
116	20	S2	0	6095.962	37390.515	773.931	9625.849	6.134	9.999+
117	20	S3	0	3915.889	37535.132	501.853	9637.111	9.585	9.999+
118	20	S4	0	4046.522	37534.83	514.282	9637.066	9.276	9.999+
119	20	S5	0	3977.513	37390.349	494.807	9624.763	9.4	9.999+
120	20	S6	0	3416.234	37296.548	508.861	9616.005	9.999+	9.999+

Slab Sliding Safety Factors (By Combination)

	LC	Slab	Angle[deg]	Va-xx[lb]	Vr-xx[lb]	Va-zz[lb]	Vr-zz[lb]	SR-xx	SR-zz
1	1	S1	0	33.412	2546.207	0	2546.207	9.999+	9.999+
2	1	S2	0	.249	2566.758	0	2566.758	9.999+	9.999+
3	1	S3	0	0	2569.896	0	2569.896	9.999+	9.999+
4	1	S4	0	0	2569.884	0	2569.884	9.999+	9.999+
5	1	S5	0	.273	2566.751	0	2566.751	9.999+	9.999+
6	1	S6	0	33.449	2546.205	0	2546.205	9.999+	9.999+
7	2	S1	0	133.803	2978.271	0	2978.271	9.999+	9.999+
8	2	S2	0	1.079	3068.466	0	3068.466	9.999+	9.999+
9	2	S3	0	4.995	3081.361	0	3081.361	9.999+	9.999+
10	2	S4	0	5.039	3081.314	0	3081.314	9.999+	9.999+
11	2	S5	0	1.17	3068.429	0	3068.429	9.999+	9.999+
12	2	S6	0	133.951	2978.26	0	2978.26	9.999+	9.999+
13	3	S1	0	119.932	1919.251	1116.694	1919.251	9.999+	1.719
14	3	S2	0	4.795	1849.439	1492.123	1849.439	9.999+	1.239
15	3	S3	0	4.474	1833.035	1396.385	1833.035	9.999+	1.313
16	3	S4	0	4.514	1833.077	1396.337	1833.077	9.999+	1.313
17	3	S5	0	4.755	1849.483	1492.202	1849.483	9.999+	1.239
18	3	S6	0	120.055	1919.258	1116.663	1919.258	9.999+	1.719
19	4	S1	0	131.922	2004.007	934.652	2004.007	9.999+	2.144
20	4	S2	0	14.059	1985.002	1252.761	1985.002	9.999+	1.585
21	4	S3	0	2.154	1950	1168.687	1950	9.999+	1.669
22	4	S4	0	2.227	1950.052	1168.632	1950.052	9.999+	1.669
23	4	S5	0	13.977	1985.086	1252.827	1985.086	9.999+	1.584
24	4	S6	0	132.062	2004.018	934.634	2004.018	9.999+	2.144
25	5	S1	0	212.312	3277.656	1302.809	3277.656	9.999+	2.516
26	5	S2	0	5.054	3403.632	1740.81	3403.632	9.999+	1.955
27	5	S3	0	5.219	3429.568	1629.116	3429.568	9.999+	2.105
28	5	S4	0	5.266	3429.493	1629.059	3429.493	9.999+	2.105
29	5	S5	0	4.957	3403.563	1740.902	3403.563	9.999+	1.955
30	5	S6	0	212.537	3277.644	1302.774	3277.644	9.999+	2.516
31	6	S1	0	156.586	3157.306	1113.421	3157.306	9.999+	2.836
32	6	S2	0	4.425	3296.942	1484.631	3296.942	9.999+	2.221
33	6	S3	0	5.102	3302.061	1392.342	3302.061	9.999+	2.372
34	6	S4	0	5.144	3302.01	1392.304	3302.01	9.999+	2.372
35	6	S5	0	4.534	3296.921	1484.709	3296.921	9.999+	2.221
36	6	S6	0	156.75	3157.3	1113.384	3157.3	9.999+	2.836
37	7	S1	0	81.106	2815.165	492.242	2815.165	9.999+	5.719
38	7	S2	0	12.182	2776.27	437.698	2776.27	9.999+	6.343
39	7	S3	0	.609	2690.154	222.43	2690.154	9.999+	9.999+
40	7	S4	0	.845	2693.497	234.388	2693.497	9.999+	9.999+
41	7	S5	0	2.078	2684.029	248.799	2684.029	9.999+	9.999+
42	7	S6	0	65.68	2652.944	185.77	2652.944	9.999+	9.999+
43	8	S1	0	6.344	2284.693	481.047	2284.693	9.999+	4.749
44	8	S2	0	7.958	2385.447	378.97	2385.447	9.999+	6.295
45	8	S3	0	.047	2449.477	224.001	2449.477	9.999+	9.999+
46	8	S4	0	0	2446.457	234.139	2446.457	9.999+	9.999+
47	8	S5	0	1.703	2448.77	248.862	2448.77	9.999+	9.84



Company : Vector Structural Engineering
 Designer : STB
 Job Number : U2716.097.191
 Model Name : Ground Mount

Apr 7, 2021
 5:15 PM
 Checked By: JSP

Slab Sliding Safety Factors (By Combination) (Continued)

	LC	Slab	Angle[deg]	Va-xx[lb]	Vr-xx[lb]	Va-zz[lb]	Vr-zz[lb]	SR-xx	SR-zz
48	8	S6	0	3.254	2440.384	185.758	2440.384	9.999+	9.999+
49	9	S1	0	6.302	2400.038	837.52	2400.038	9.999+	2.866
50	9	S2	0	4.281	2405.049	1119.092	2405.049	9.999+	2.149
51	9	S3	0	.391	2400.849	1047.289	2400.849	9.999+	2.292
52	9	S4	0	.394	2400.851	1047.252	2400.851	9.999+	2.293
53	9	S5	0	4.307	2405.058	1119.151	2405.058	9.999+	2.149
54	9	S6	0	6.302	2400.036	837.498	2400.036	9.999+	2.866
55	10	S1	0	15.295	2463.605	700.989	2463.605	9.999+	3.514
56	10	S2	0	11.229	2506.722	939.571	2506.722	9.999+	2.668
57	10	S3	0	2.131	2488.573	876.515	2488.573	9.999+	2.839
58	10	S4	0	2.109	2488.583	876.474	2488.583	9.999+	2.839
59	10	S5	0	11.224	2506.761	939.62	2506.761	9.999+	2.668
60	10	S6	0	15.307	2463.606	700.975	2463.606	9.999+	3.515
61	11	S1	0	242.881	3418.842	977.107	3418.842	9.999+	3.499
62	11	S2	0	3.106	3570.694	1305.608	3570.694	9.999+	2.735
63	11	S3	0	7.661	3598.249	1221.837	3598.249	9.999+	2.945
64	11	S4	0	7.728	3598.163	1221.795	3598.163	9.999+	2.945
65	11	S5	0	2.976	3570.618	1305.677	3570.618	9.999+	2.735
66	11	S6	0	243.142	3418.825	977.08	3418.825	9.999+	3.499
67	12	S1	0	201.086	3328.579	835.066	3328.579	9.999+	3.986
68	12	S2	0	4.003	3490.677	1113.473	3490.677	9.999+	3.135
69	12	S3	0	7.573	3502.619	1044.256	3502.619	9.999+	3.354
70	12	S4	0	7.637	3502.551	1044.228	3502.551	9.999+	3.354
71	12	S5	0	4.142	3490.637	1113.532	3490.637	9.999+	3.135
72	12	S6	0	201.301	3328.567	835.038	3328.567	9.999+	3.986
73	13	S1	0	144.476	3071.973	369.182	3071.973	9.999+	8.321
74	13	S2	0	9.82	3100.173	328.273	3100.173	9.999+	9.444
75	13	S3	0	4.203	3043.688	166.822	3043.688	9.999+	9.999+
76	13	S4	0	3.145	3046.166	175.791	3046.166	9.999+	9.999+
77	13	S5	0	.818	3030.968	186.599	3030.968	9.999+	9.999+
78	13	S6	0	132.999	2950.3	139.328	2950.3	9.999+	9.999+
79	14	S1	0	78.889	2674.12	360.785	2674.12	9.999+	7.412
80	14	S2	0	5.284	2807.055	284.227	2807.055	9.999+	9.876
81	14	S3	0	3.711	2863.181	168.001	2863.181	9.999+	9.999+
82	14	S4	0	3.779	2860.886	175.604	2860.886	9.999+	9.999+
83	14	S5	0	2.018	2854.523	186.647	2854.523	9.999+	9.999+
84	14	S6	0	86.18	2790.88	139.319	2790.88	9.999+	9.999+
85	15	S1	0	123.273	1664.63	1116.694	1664.63	9.999+	1.491
86	15	S2	0	4.771	1592.763	1492.123	1592.763	9.999+	1.067
87	15	S3	0	4.474	1576.045	1396.385	1576.045	9.999+	1.129
88	15	S4	0	4.514	1576.089	1396.337	1576.089	9.999+	1.129
89	15	S5	0	4.728	1592.808	1492.202	1592.808	9.999+	1.067
90	15	S6	0	123.4	1664.637	1116.663	1664.637	9.999+	1.491
91	16	S1	0	135.264	1749.387	934.652	1749.387	9.999+	1.872
92	16	S2	0	14.034	1728.326	1252.761	1728.326	9.999+	1.38
93	16	S3	0	2.154	1693.01	1168.687	1693.01	9.999+	1.449
94	16	S4	0	2.227	1693.064	1168.632	1693.064	9.999+	1.449
95	16	S5	0	13.949	1728.411	1252.827	1728.411	9.999+	1.38
96	16	S6	0	135.407	1749.398	934.634	1749.398	9.999+	1.872
97	17	S1	0	208.971	3023.035	1302.809	3023.035	9.999+	2.32
98	17	S2	0	5.079	3146.956	1740.81	3146.956	9.999+	1.808
99	17	S3	0	5.219	3172.578	1629.116	3172.578	9.999+	1.947
100	17	S4	0	5.266	3172.504	1629.059	3172.504	9.999+	1.947
101	17	S5	0	4.984	3146.888	1740.902	3146.888	9.999+	1.808
102	17	S6	0	209.192	3023.024	1302.774	3023.024	9.999+	2.32
103	18	S1	0	153.245	2902.685	1113.421	2902.685	9.999+	2.607
104	18	S2	0	4.401	3040.266	1484.631	3040.266	9.999+	2.048



Slab Sliding Safety Factors (By Combination) (Continued)

	LC	Slab	Angle[deg]	Va-xx[lb]	Vr-xx[lb]	Va-zz[lb]	Vr-zz[lb]	SR-xx	SR-zz
105	18	S3	0	5.102	3045.071	1392.342	3045.071	9.999+	2.187
106	18	S4	0	5.144	3045.022	1392.304	3045.022	9.999+	2.187
107	18	S5	0	4.507	3040.246	1484.709	3040.246	9.999+	2.048
108	18	S6	0	153.405	2902.679	1113.384	2902.679	9.999+	2.607
109	19	S1	0	77.765	2560.544	492.242	2560.544	9.999+	5.202
110	19	S2	0	12.157	2519.594	437.698	2519.594	9.999+	5.756
111	19	S3	0	.609	2433.164	222.43	2433.164	9.999+	9.999+
112	19	S4	0	.845	2436.508	234.388	2436.508	9.999+	9.999+
113	19	S5	0	2.106	2427.354	248.799	2427.354	9.999+	9.756
114	19	S6	0	62.335	2398.324	185.77	2398.324	9.999+	9.999+
115	20	S1	0	9.685	2030.073	481.047	2030.073	9.999+	4.22
116	20	S2	0	7.983	2128.771	378.97	2128.771	9.999+	5.617
117	20	S3	0	.047	2192.488	224.001	2192.488	9.999+	9.788
118	20	S4	0	0	2189.468	234.139	2189.468	9.999+	9.351
119	20	S5	0	1.676	2192.094	248.862	2192.094	9.999+	8.808
120	20	S6	0	.091	2185.764	185.758	2185.764	9.999+	9.999+

Envelope Slab Soil Pressures

	Label	UC	LC	Soil Pressure[psf]	Allowable Bearing[psf]	Point
1	S1	.446	5	669.73	1500	N170
2	S2	.484	5	726.536	1500	N177
3	S3	.486	5	728.964	1500	N184
4	S4	.486	5	728.922	1500	N191
5	S5	.484	5	726.516	1500	N198
6	S6	.446	5	669.72	1500	N205



Company:		Date:	5/14/2018
Engineer:		Page:	1/6
Project:			
Address:			
Phone:			
E-mail:			

1. Project information

Customer company:
Customer contact name:
Customer e-mail:
Comment:

Project description:
Location:
Fastening description:

2. Input Data & Anchor Parameters

General

Design method: ACI 318-14
Units: Imperial units

Anchor Information:

Anchor type: Bonded anchor
Material: F1554 Grade 36
Diameter (inch): 0.375
Effective Embedment depth, h_{ef} (inch): 4.000
Code report: ICC-ES ESR-4057
Anchor category: -
Anchor ductility: Yes
 h_{min} (inch): 5.25
 c_{ac} (inch): 7.12
 C_{min} (inch): 1.75
 S_{min} (inch): 3.00

Base Material

Concrete: Normal-weight
Concrete thickness, h (inch): 24.00
State: Cracked
Compressive strength, f'_c (psi): 2500
 $\Psi_{c,v}$: 1.0
Reinforcement condition: B tension, B shear
Supplemental reinforcement: Not applicable
Reinforcement provided at corners: No
Ignore concrete breakout in tension: No
Ignore concrete breakout in shear: No
Hole condition: Dry concrete
Inspection: Periodic
Temperature range, Short/Long: 150/110°F
Ignore 6do requirement: Not applicable
Build-up grout pad: No

Base Plate

Length x Width x Thickness (inch): 4.75 x 4.75 x 0.31

Recommended Anchor

Anchor Name: SET-3G - SET-3G w/ 3/8"Ø F1554 Gr. 36
Code Report: ICC-ES ESR-4057





Company:		Date:	5/14/2018
Engineer:		Page:	2/6
Project:			
Address:			
Phone:			
E-mail:			

Load and Geometry

Load factor source: ACI 318 Section 5.3

Load combination: not set

Seismic design: No

Anchors subjected to sustained tension: No

Apply entire shear load at front row: No

Anchors only resisting wind and/or seismic loads: No

Strength level loads:

N_{ua} [lb]: 4523

V_{uax} [lb]: 525

V_{uay} [lb]: -2997

M_{ux} [ft-lb]: 0

M_{uy} [ft-lb]: 0

M_{uz} [ft-lb]: 0

<Figure 1>

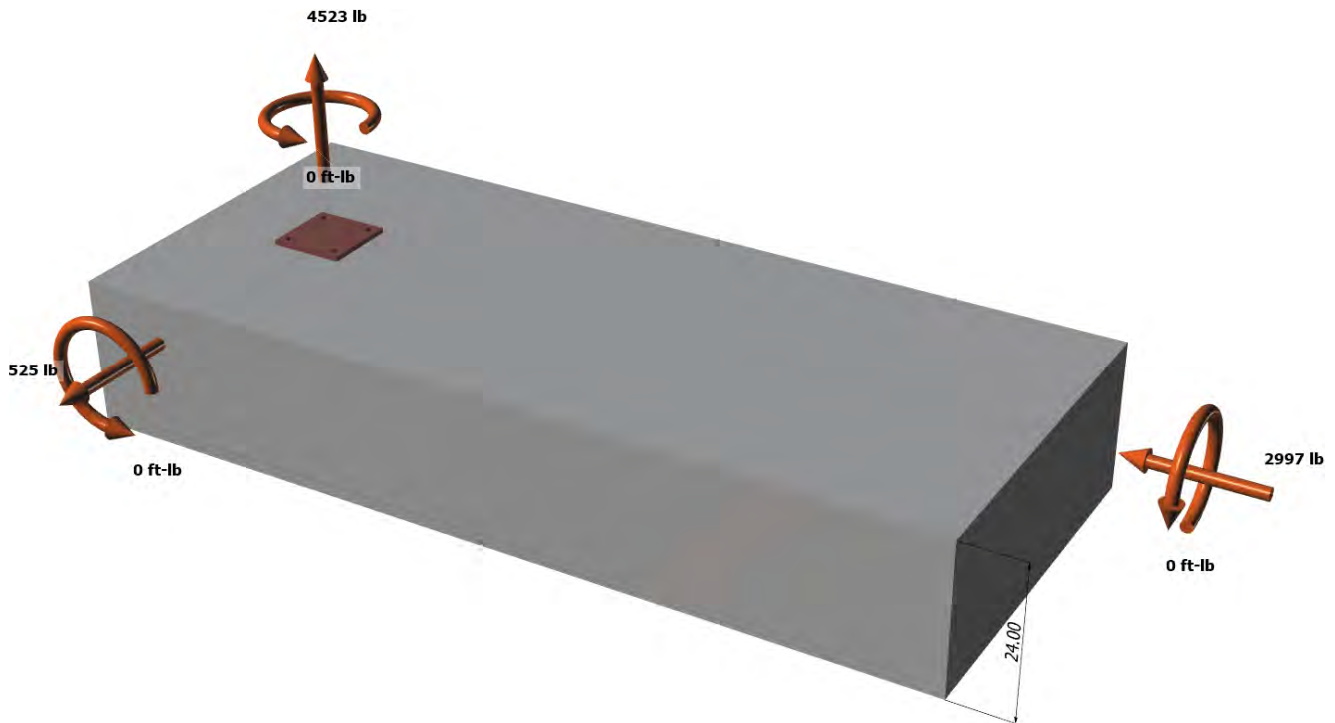



Company:		Date:	5/14/2018
Engineer:		Page:	3/6
Project:			
Address:			
Phone:			
E-mail:			

<Figure 2>

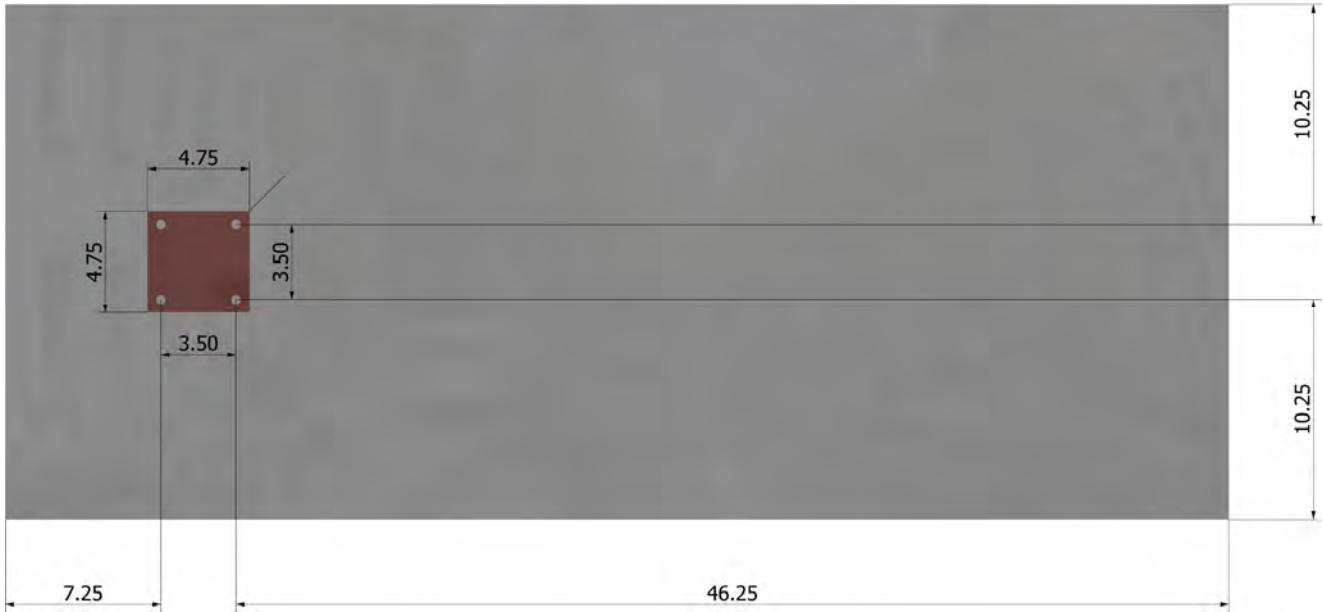



Company:		Date:	5/14/2018
Engineer:		Page:	4/6
Project:			
Address:			
Phone:			
E-mail:			

3. Resulting Anchor Forces

Anchor	Tension load, N _{ua} (lb)	Shear load x, V _{uax} (lb)	Shear load y, V _{uay} (lb)	Shear load combined, $\sqrt{(V_{uax})^2 + (V_{uay})^2}$ (lb)
1	1130.8	131.3	-749.3	760.7
2	1130.8	131.3	-749.3	760.7
3	1130.8	131.3	-749.3	760.7
4	1130.8	131.3	-749.3	760.7
Sum	4523.0	525.0	-2997.0	3042.6

Maximum concrete compression strain (%): 0.00
 Maximum concrete compression stress (psi): 0
 Resultant tension force (lb): 4523
 Resultant compression force (lb): 0
 Eccentricity of resultant tension forces in x-axis, e'_{Nx} (inch): 0.00
 Eccentricity of resultant tension forces in y-axis, e'_{Ny} (inch): 0.00
 Eccentricity of resultant shear forces in x-axis, e'_{Vx} (inch): 0.00
 Eccentricity of resultant shear forces in y-axis, e'_{Vy} (inch): 0.00

<Figure 3>

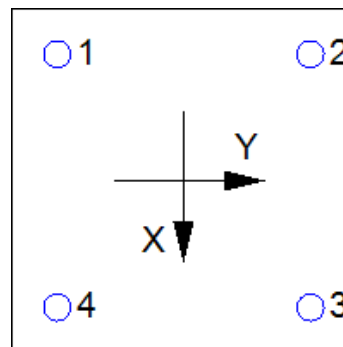

4. Steel Strength of Anchor in Tension (Sec. 17.4.1)

N _{sa} (lb)	φ	φN _{sa} (lb)
4525	0.75	3394

5. Concrete Breakout Strength of Anchor in Tension (Sec. 17.4.2)

$$N_b = K_c \lambda_a \sqrt{f_c} h_{ef}^{1.5} \text{ (Eq. 17.4.2.2a)}$$

K _c	λ _a	f _c (psi)	h _{ef} (in)	N _b (lb)
17.0	1.00	2500	4.000	6800

$$\phi N_{cbg} = \phi (A_{Nc} / A_{Nco}) \Psi_{ec,N} \Psi_{ed,N} \Psi_{c,N} \Psi_{cp,N} N_b \text{ (Sec. 17.3.1 \& Eq. 17.4.2.1b)}$$

A _{Nc} (in ²)	A _{Nco} (in ²)	c _{a,min} (in)	Ψ _{ec,N}	Ψ _{ed,N}	Ψ _{c,N}	Ψ _{cp,N}	N _b (lb)	φ	φN _{cbg} (lb)
240.25	144.00	7.25	1.000	1.000	1.00	1.000	6800	0.65	7374

6. Adhesive Strength of Anchor in Tension (Sec. 17.4.5)

$$\tau_{k,cr} = \tau_{k,cr,short-term} K_{sat} (f_c / 2,500)^n$$

τ _{k,cr} (psi)	f _{short-term}	K _{sat}	f _c (psi)	n	τ _{k,cr} (psi)
1346	1.00	1.00	2500	0.24	1346

$$N_{ba} = \lambda_a \tau_{cr} \pi d_a h_{ef} \text{ (Eq. 17.4.5.2)}$$

λ _a	τ _{cr} (psi)	d _a (in)	h _{ef} (in)	N _{ba} (lb)
1.00	1346	0.38	4.000	6343

$$\phi N_{ag} = \phi (A_{Na} / A_{Na0}) \Psi_{ec,Na} \Psi_{ed,Na} \Psi_{cp,Na} N_{ba} \text{ (Sec. 17.3.1 \& Eq. 17.4.5.1b)}$$

A _{Na} (in ²)	A _{Na0} (in ²)	c _{Na} (in)	c _{a,min} (in)	Ψ _{ec,Na}	Ψ _{ed,Na}	Ψ _{cp,Na}	N _{ba} (lb)	φ	φN _{ag} (lb)
198.45	112.09	5.29	7.25	1.000	1.000	1.000	6343	0.55	6176



Company:		Date:	5/14/2018
Engineer:		Page:	5/6
Project:			
Address:			
Phone:			
E-mail:			

8. Steel Strength of Anchor in Shear (Sec. 17.5.1)

V_{sa} (lb)	ϕ_{grout}	ϕ	$\phi_{grout}\phi V_{sa}$ (lb)
2715	1.0	0.65	1765

9. Concrete Breakout Strength of Anchor in Shear (Sec. 17.5.2)

Shear perpendicular to edge in x-direction:

$V_{bx} = \min|7(l_e / d_a)^{0.2} \sqrt{d_a} \lambda_a \sqrt{f_c} c_{a1}^{1.5}; 9 \lambda_a \sqrt{f_c} c_{a1}^{1.5}|$ (Eq. 17.5.2.2a & Eq. 17.5.2.2b)

l_e (in)	d_a (in)	λ_a	f_c (psi)	c_{a1} (in)	V_{bx} (lb)
3.00	0.375	1.00	2500	13.75	16564

$\phi V_{cbgx} = \phi (A_{Vc} / A_{Vco}) \Psi_{ec,V} \Psi_{ed,V} \Psi_{c,V} \Psi_{h,V} V_{bx}$ (Sec. 17.3.1 & Eq. 17.5.2.1b)

A_{Vc} (in ²)	A_{Vco} (in ²)	$\Psi_{ec,V}$	$\Psi_{ed,V}$	$\Psi_{c,V}$	$\Psi_{h,V}$	V_{bx} (lb)	ϕ	ϕV_{cbgx} (lb)
647.11	850.78	1.000	0.805	1.000	1.000	16564	0.70	7103

Shear perpendicular to edge in y-direction:

$V_{by} = \min|7(l_e / d_a)^{0.2} \sqrt{d_a} \lambda_a \sqrt{f_c} c_{a1}^{1.5}; 9 \lambda_a \sqrt{f_c} c_{a1}^{1.5}|$ (Eq. 17.5.2.2a & Eq. 17.5.2.2b)

l_e (in)	d_a (in)	λ_a	f_c (psi)	c_{a1} (in)	V_{by} (lb)
3.00	0.375	1.00	2500	10.75	11450

$\phi V_{cbgy} = \phi (A_{Vc} / A_{Vco}) \Psi_{ec,V} \Psi_{ed,V} \Psi_{c,V} \Psi_{h,V} V_{by}$ (Sec. 17.3.1 & Eq. 17.5.2.1b)

A_{Vc} (in ²)	A_{Vco} (in ²)	$\Psi_{ec,V}$	$\Psi_{ed,V}$	$\Psi_{c,V}$	$\Psi_{h,V}$	V_{by} (lb)	ϕ	ϕV_{cbgy} (lb)
387.00	520.03	1.000	0.891	1.000	1.000	11450	0.70	5313

Shear parallel to edge in x-direction:

$V_{by} = \min|7(l_e / d_a)^{0.2} \sqrt{d_a} \lambda_a \sqrt{f_c} c_{a1}^{1.5}; 9 \lambda_a \sqrt{f_c} c_{a1}^{1.5}|$ (Eq. 17.5.2.2a & Eq. 17.5.2.2b)

l_e (in)	d_a (in)	λ_a	f_c (psi)	c_{a1} (in)	V_{by} (lb)
3.00	0.375	1.00	2500	7.25	6342

$\phi V_{cbgx} = \phi (2)(A_{Vc} / A_{Vco}) \Psi_{ec,V} \Psi_{ed,V} \Psi_{c,V} \Psi_{h,V} V_{by}$ (Sec. 17.3.1, 17.5.2.1(c) & Eq. 17.5.2.1b)

A_{Vc} (in ²)	A_{Vco} (in ²)	$\Psi_{ec,V}$	$\Psi_{ed,V}$	$\Psi_{c,V}$	$\Psi_{h,V}$	V_{by} (lb)	ϕ	ϕV_{cbgx} (lb)
261.00	236.53	1.000	1.000	1.000	1.000	6342	0.70	9797

Shear parallel to edge in y-direction:

$V_{bx} = \min|7(l_e / d_a)^{0.2} \sqrt{d_a} \lambda_a \sqrt{f_c} c_{a1}^{1.5}; 9 \lambda_a \sqrt{f_c} c_{a1}^{1.5}|$ (Eq. 17.5.2.2a & Eq. 17.5.2.2b)

l_e (in)	d_a (in)	λ_a	f_c (psi)	c_{a1} (in)	V_{bx} (lb)
3.00	0.375	1.00	2500	10.25	10661

$\phi V_{cbgy} = \phi (2)(A_{Vc} / A_{Vco}) \Psi_{ec,V} \Psi_{ed,V} \Psi_{c,V} \Psi_{h,V} V_{bx}$ (Sec. 17.3.1, 17.5.2.1(c) & Eq. 17.5.2.1b)

A_{Vc} (in ²)	A_{Vco} (in ²)	$\Psi_{ec,V}$	$\Psi_{ed,V}$	$\Psi_{c,V}$	$\Psi_{h,V}$	V_{bx} (lb)	ϕ	ϕV_{cbgy} (lb)
401.67	472.78	1.000	1.000	1.000	1.000	10661	0.70	12680

10. Concrete Pryout Strength of Anchor in Shear (Sec. 17.5.3)

$\phi V_{cp} = \phi \min|k_{cp} N_{ag}; k_{cp} N_{cbg}| = \phi \min|k_{cp} (A_{Na} / A_{Na0}) \Psi_{ec,Na} \Psi_{ed,Na} \Psi_{cp,Na} N_{ba}; k_{cp} (A_{Nc} / A_{Nco}) \Psi_{ec,N} \Psi_{ed,N} \Psi_{c,N} \Psi_{cp,N} N_b|$ (Sec. 17.3.1 & Eq. 17.5.3.1b)

k_{cp}	A_{Na} (in ²)	A_{Na0} (in ²)	$\Psi_{ed,Na}$	$\Psi_{ec,Na}$	$\Psi_{cp,Na}$	N_{ba} (lb)	N_a (lb)
2.0	198.45	112.09	1.000	1.000	1.000	6343	11230

A_{Nc} (in ²)	A_{Nco} (in ²)	$\Psi_{ec,N}$	$\Psi_{ed,N}$	$\Psi_{c,N}$	$\Psi_{cp,N}$	N_b (lb)	N_{cb} (lb)	ϕ
240.25	144.00	1.000	1.000	1.000	1.000	6800	11345	0.70

Input data and results must be checked for agreement with the existing circumstances, the standards and guidelines must be checked for plausibility.



Company:		Date:	5/14/2018
Engineer:		Page:	6/6
Project:			
Address:			
Phone:			
E-mail:			

ϕV_{cpq} (lb)
15722

11. Results

Interaction of Tensile and Shear Forces (Sec. R17.6)

Tension	Factored Load, N_{ua} (lb)	Design Strength, ϕN_n (lb)	Ratio	Status	
Steel	1131	3394	0.33	Pass	
Concrete breakout	4523	7374	0.61	Pass	
Adhesive	4523	6176	0.73	Pass (Governs)	
Shear	Factored Load, V_{ua} (lb)	Design Strength, ϕV_n (lb)	Ratio	Status	
Steel	761	1765	0.43	Pass	
T Concrete breakout x+	525	7103	0.07	Pass	
T Concrete breakout y-	2997	5313	0.56	Pass	
Concrete breakout y-	263	9797	0.03	Pass	
Concrete breakout x-	1499	12680	0.12	Pass	
Concrete breakout, combined	-	-	0.57	Pass (Governs)	
Pryout	3043	15722	0.19	Pass	
Interaction check	$(N_{ua}/\phi N_{ua})^{5/3}$	$(V_{ua}/\phi V_{ua})^{5/3}$	Combined Ratio	Permissible	Status
Sec. R17.6	0.59	0.39	98.6%	1.0	Pass

SET-3G w/ 3/8"Ø F1554 Gr. 36 with hef = 4.000 inch meets the selected design criteria.

12. Warnings

- Designer must exercise own judgement to determine if this design is suitable.
- Refer to manufacturer's product literature for hole cleaning and installation instructions.



JOB NO.: U2716-094-191

DESIGNED: STB

Framing Analysis

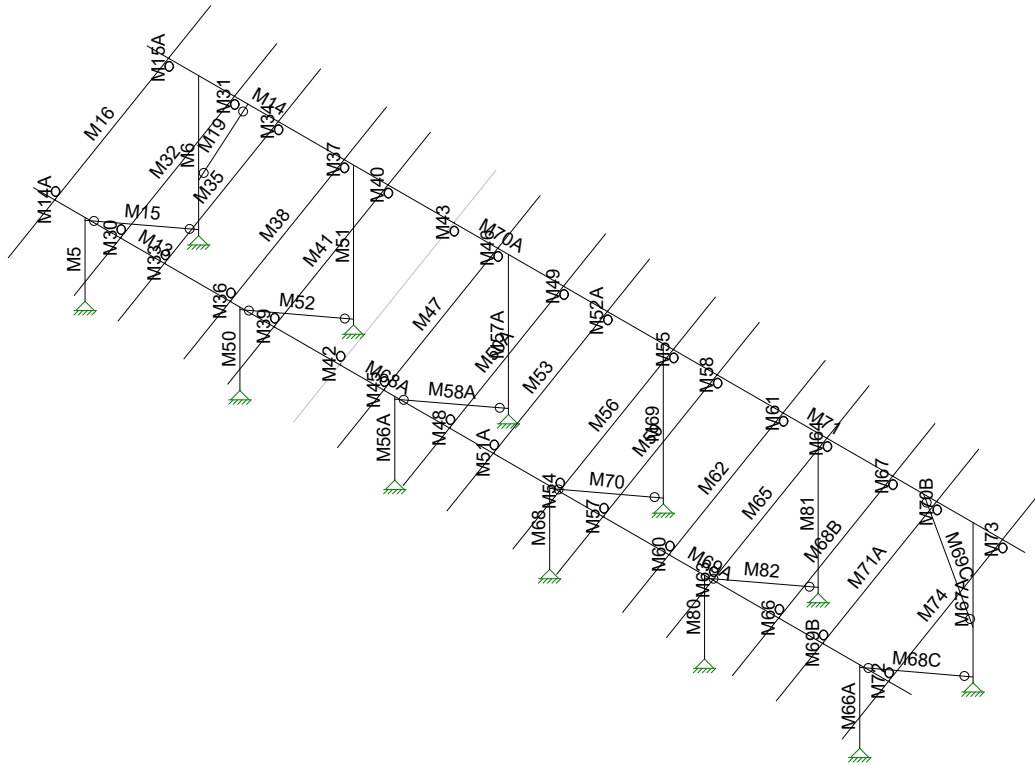

Vector Structural Engineeri...
STB
U2716.094.191

Ground Mount

SK - 3
Apr 7, 2021 at 5:10 PM
Sunmodo Sunturf B3 GM v6 85x45...

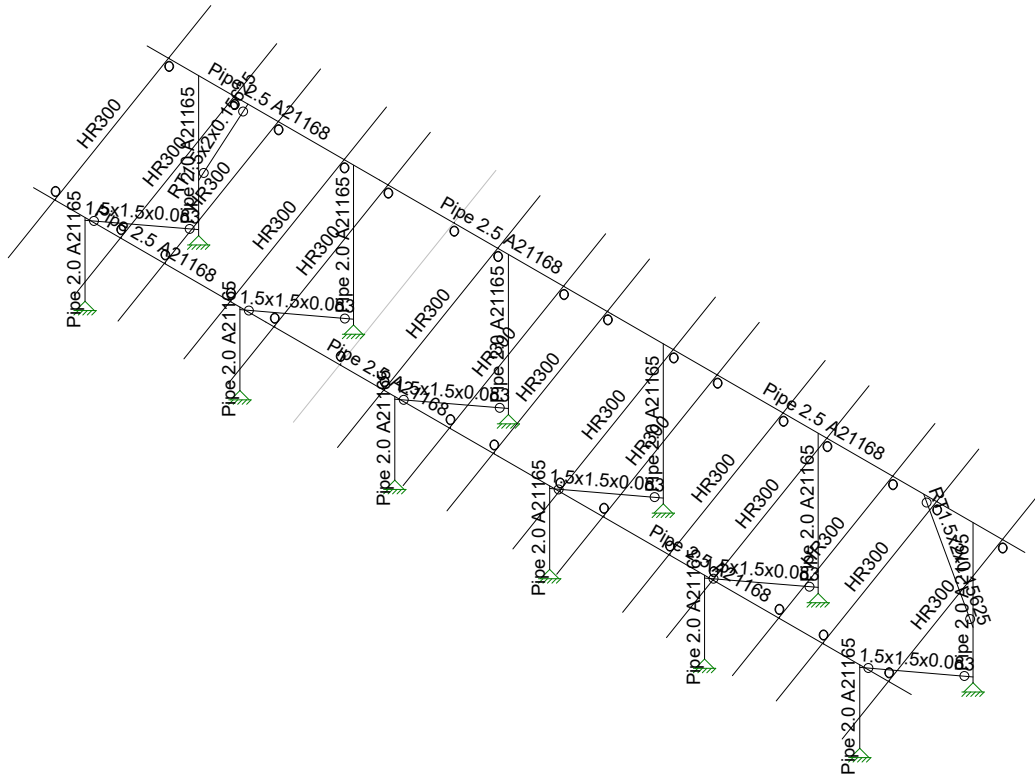

Vector Structural Engineeri...
STB
U2716.094.191

Ground Mount

SK - 4

Apr 7, 2021 at 5:10 PM

Sunmodo Sunturf B3 GM v6 85x45...

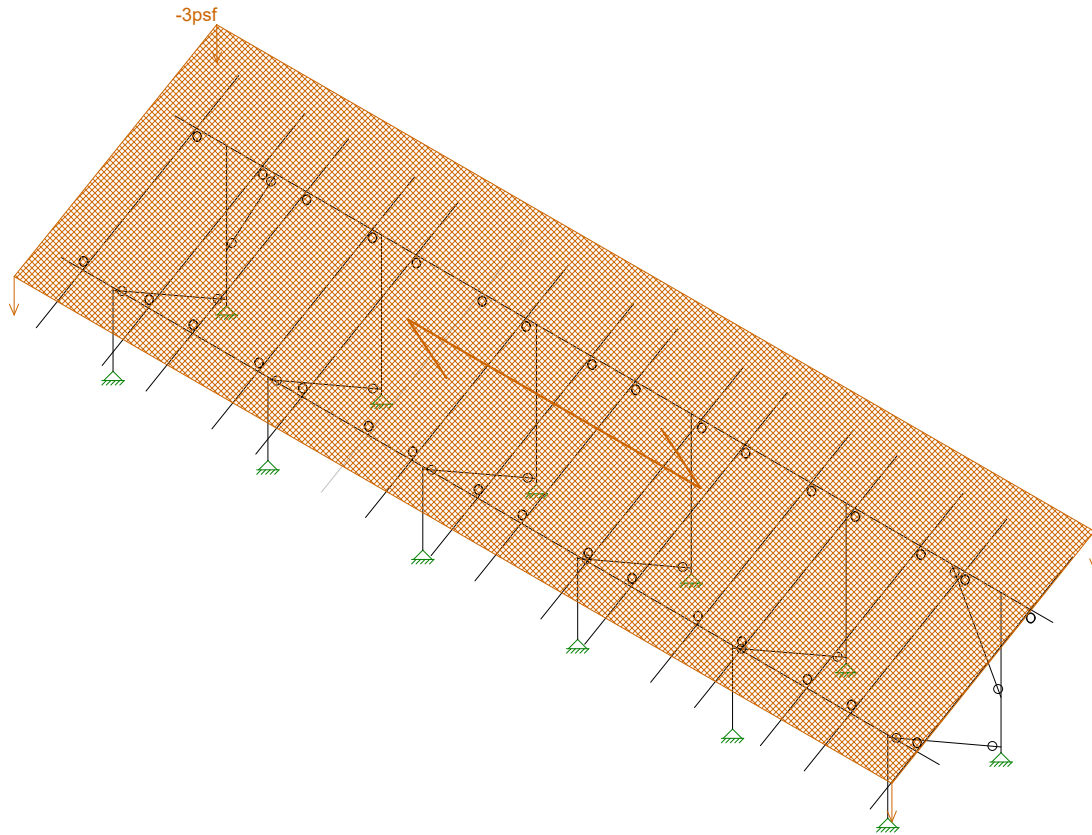

Loads: BLC 2, Solar Panel Weight

Vector Structural Engineeri...	Ground Mount	SK - 5
STB		Apr 7, 2021 at 5:10 PM
U2716.094.191		Sunmodo Sunturf B3 GM v6 85x45...

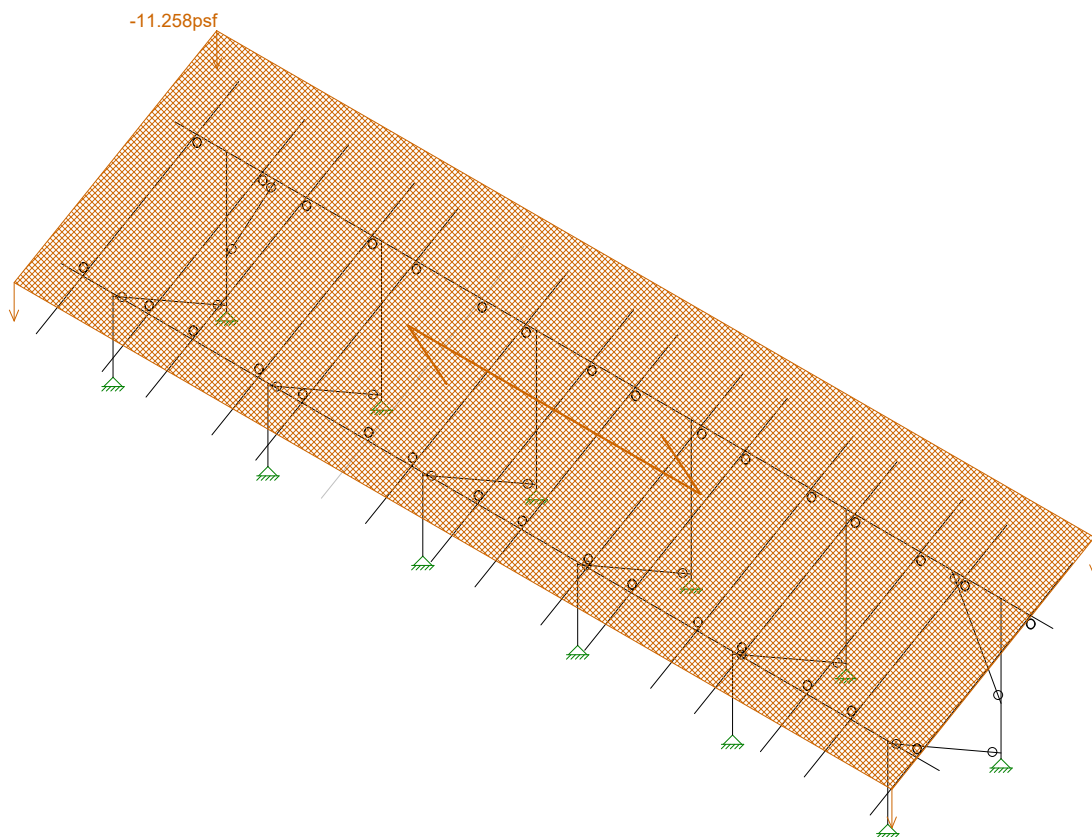

Loads: BLC 3, Roof Live/Snow

Vector Structural Engineeri...

STB

U2716.094.191

Ground Mount

SK - 6

Apr 7, 2021 at 5:10 PM

Sunmodo Sunturf B3 GM v6 85x45...

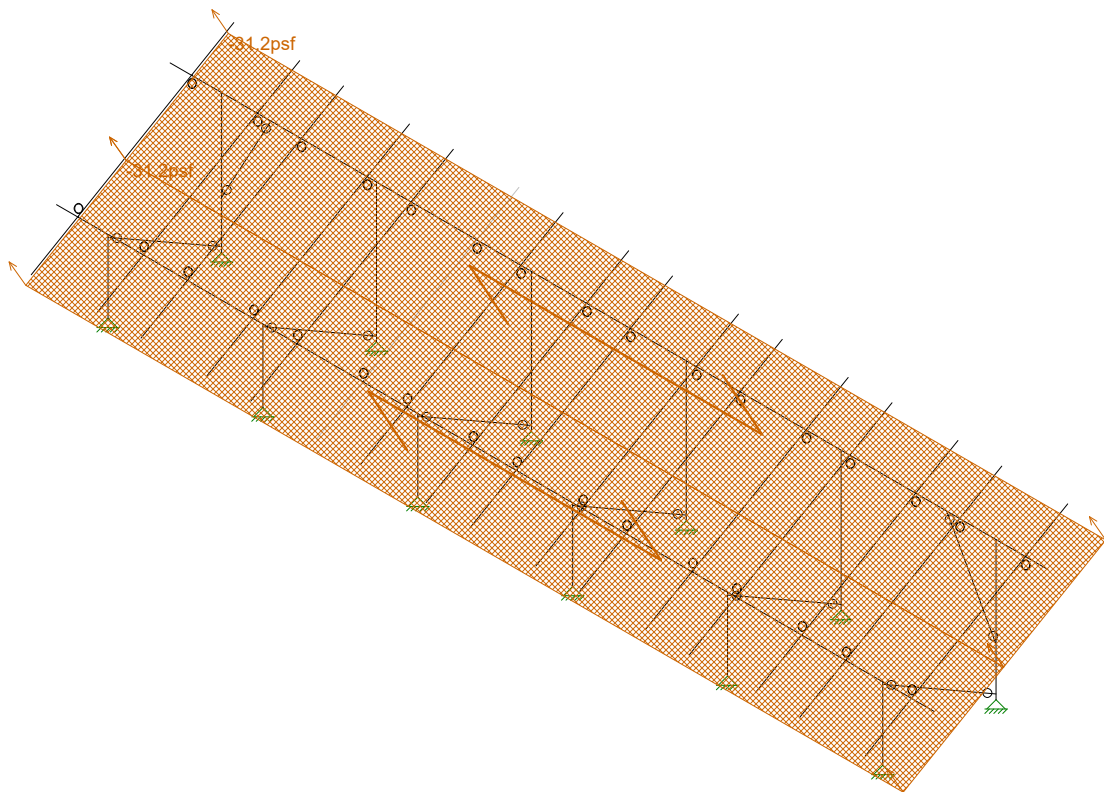

Loads: BLC 4, Wind A 0 deg

Vector Structural Engineeri...
STB
U2716.094.191

Ground Mount

SK - 7

Apr 7, 2021 at 5:10 PM

Sunmodo Sunturf B3 GM v6 85x45...

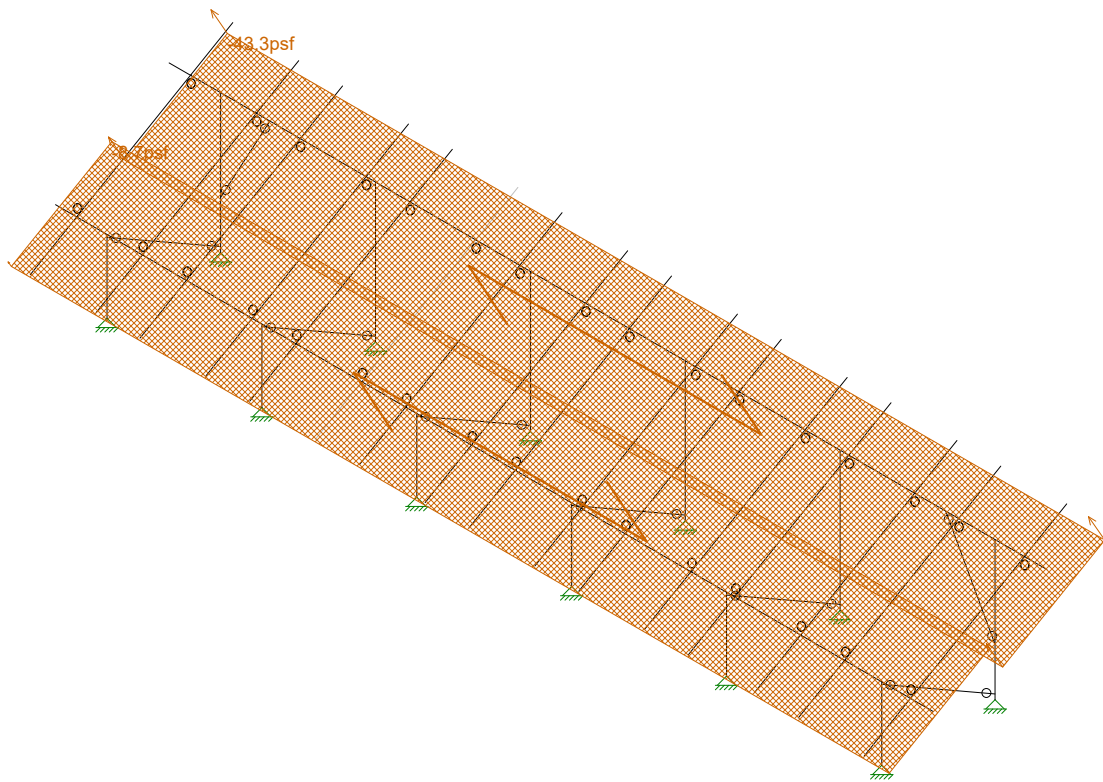

Loads: BLC 5, Wind B 0 deg

Vector Structural Engineeri...	Ground Mount	SK - 8
STB		Apr 7, 2021 at 5:10 PM
U2716.094.191		Sunmodo Sunturf B3 GM v6 85x45...

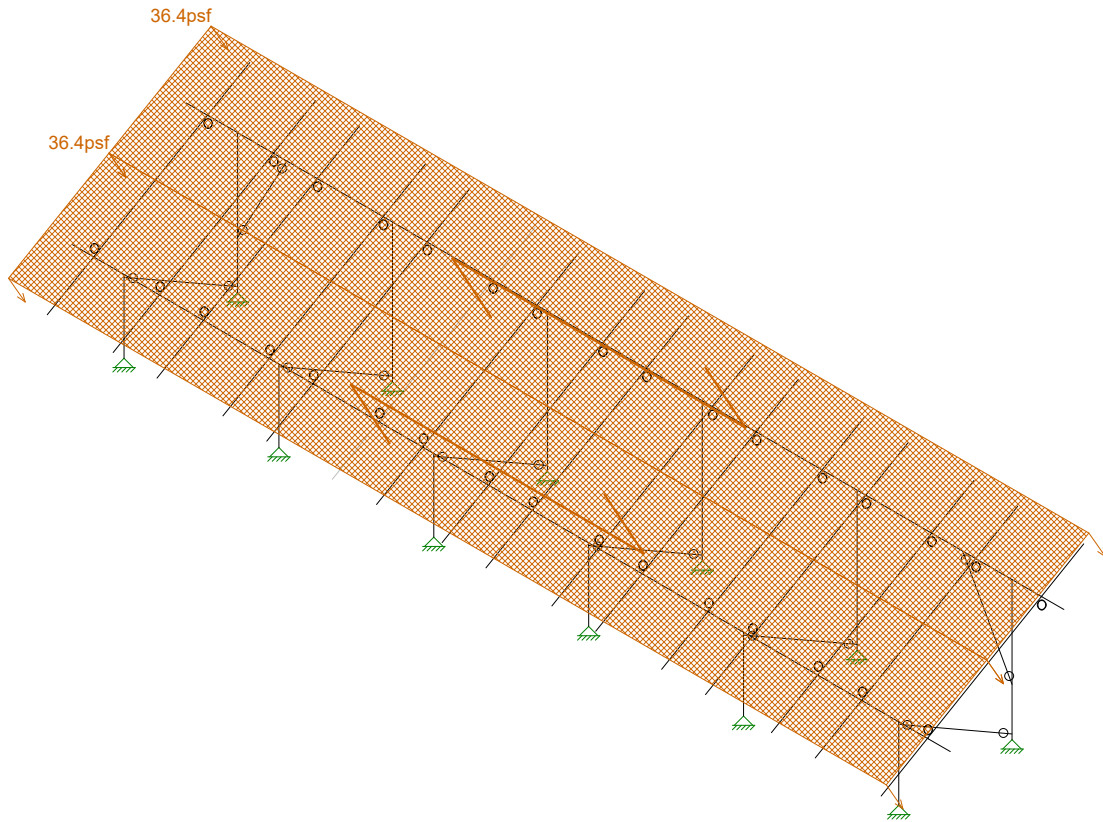

Loads: BLC 6, Wind A 180 deg

Vector Structural Engineeri...
STB
U2716.094.191

Ground Mount

SK - 9

Apr 7, 2021 at 5:10 PM

Sunmodo Sunturf B3 GM v6 85x45...

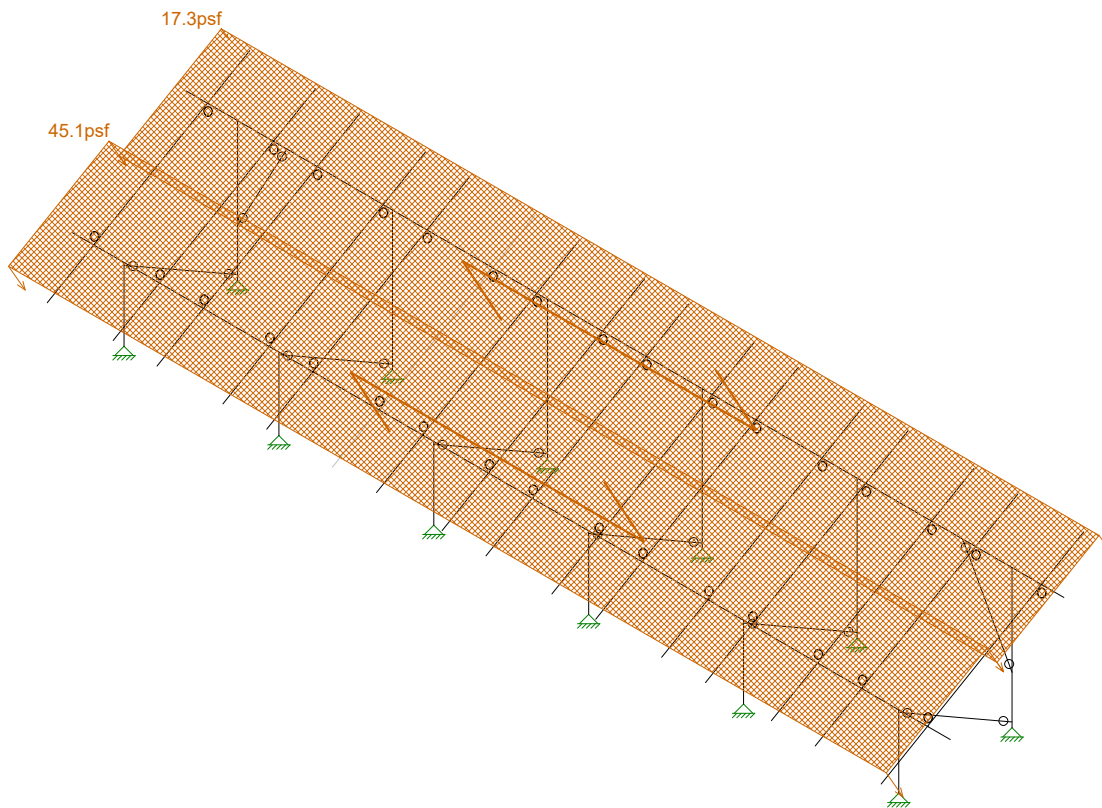

Loads: BLC 7, Wind B 180 deg

Vector Structural Engineeri..	Ground Mount	SK - 10
STB		Apr 7, 2021 at 5:10 PM
U2716.094.191		Sunmodo Sunturf B3 GM v6 85x45...

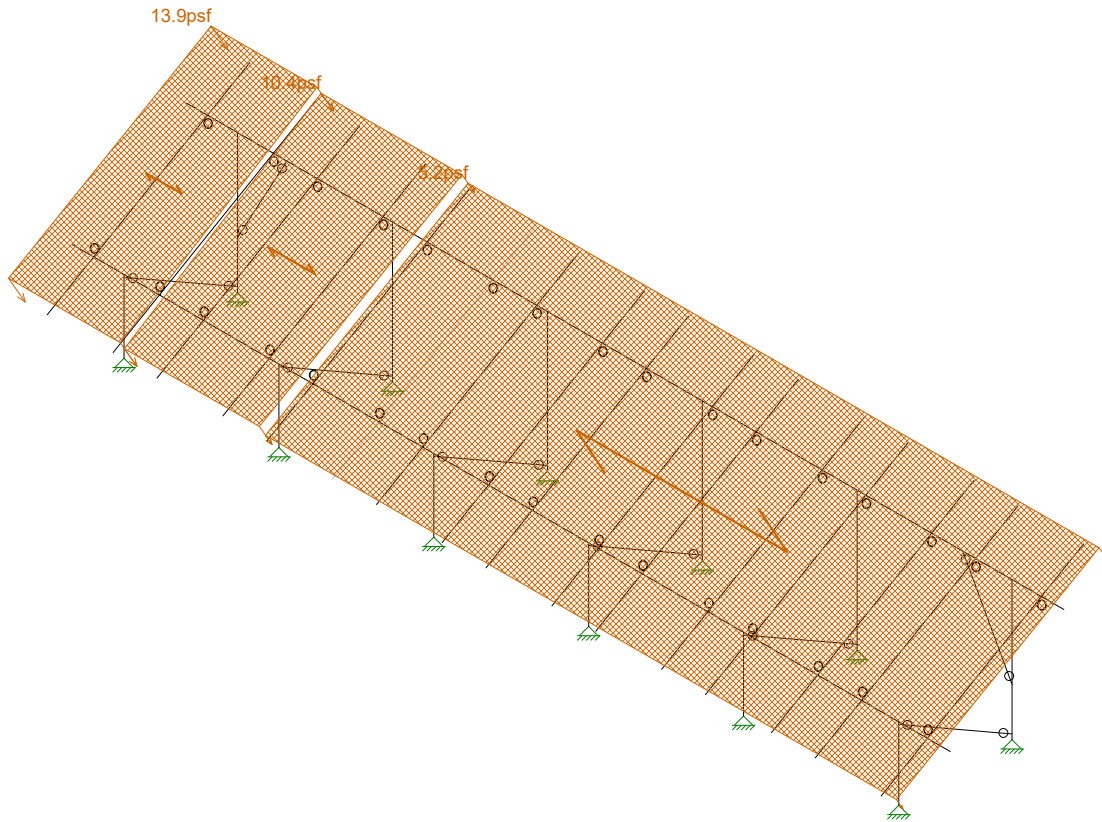

Loads: BLC 8, Wind A 90

Vector Structural Engineeri...	Ground Mount	SK - 11
STB		Apr 7, 2021 at 5:11 PM
U2716.094.191		Sunmodo Sunturf B3 GM v6 85x45...

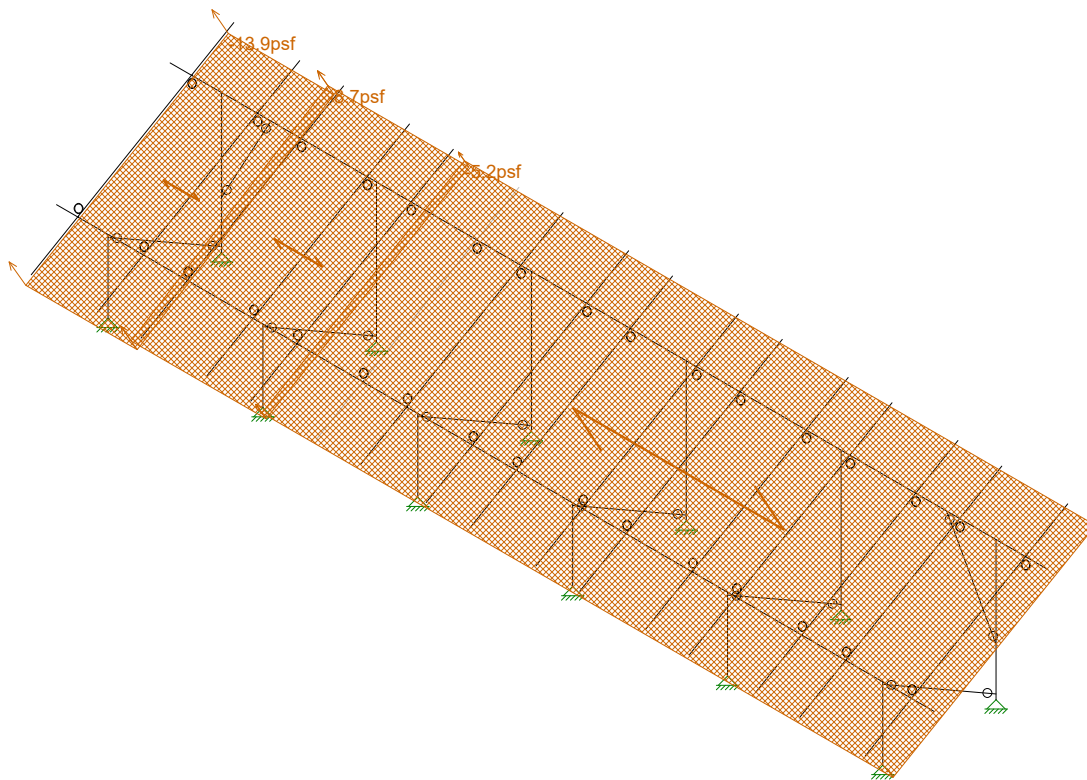

Loads: BLC 9, Wind B 90

Vector Structural Engineeri...	Ground Mount	SK - 12
STB		Apr 7, 2021 at 5:11 PM
U2716.094.191		Sunmodo Sunturf B3 GM v6 85x45...



Shear Check
(Env)

- No Calc
- > 1.0
- .90-1.0
- .75-.90
- .50-.75
- 0-.50

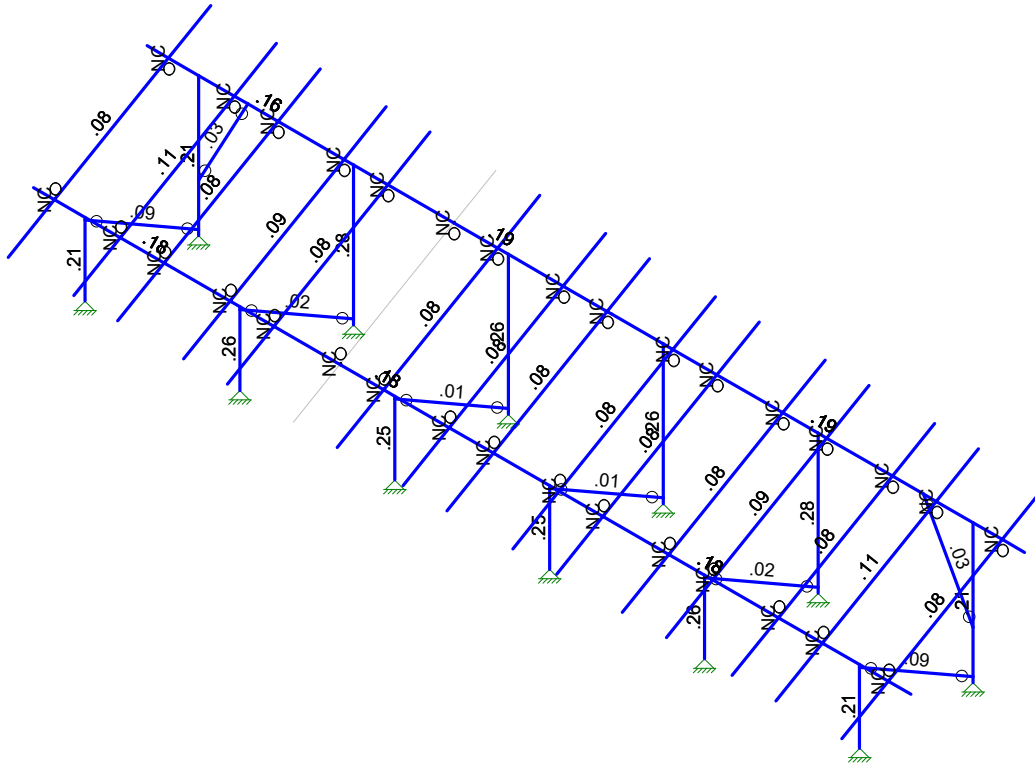

Member Shear Checks Displayed (Enveloped)
Envelope Only Solution

Vector Structural Engineeri...
STB
U2716.094.191

Ground Mount

SK - 2

Apr 7, 2021 at 5:09 PM

Sunmodo Sunturf B3 GM v6 85x45...



Company : Vector Structural Engineering
 Designer : STB
 Job Number : U2716.094.191
 Model Name : Ground Mount

Apr 7, 2021
 5:11 PM
 Checked By: _____

(Global) Model Settings

Display Sections for Member Calcs	5
Max Internal Sections for Member Calcs	97
Include Shear Deformation?	Yes
Increase Nailing Capacity for Wind?	Yes
Include Warping?	Yes
Trans Load Btwn Intersecting Wood Wall?	Yes
Area Load Mesh (in^2)	144
Merge Tolerance (in)	.12
P-Delta Analysis Tolerance	0.50%
Include P-Delta for Walls?	Yes
Automatically Iterate Stiffness for Walls?	Yes
Max Iterations for Wall Stiffness	3
Gravity Acceleration (in/sec^2)	386.4
Wall Mesh Size (in)	24
Eigensolution Convergence Tol. (1.E-)	4
Vertical Axis	Y
Global Member Orientation Plane	XZ
Static Solver	Sparse Accelerated
Dynamic Solver	Accelerated Solver

Hot Rolled Steel Code	AISC 15th(360-16): ASD
Adjust Stiffness?	Yes(Iterative)
RISACONNECTION CODE	AISC 15th(360-16): ASD
Cold Formed Steel Code	AISI S100-16: ASD
Wood Code	AWC NDS-18: ASD
Wood Temperature	< 100F
Concrete Code	ACI 318-14
Masonry Code	None
Aluminum Code	AA ADM1-15: ASD - Building
Stainless Steel Code	AISC 14th(360-10): ASD
Adjust Stiffness?	Yes(Iterative)

Number of Shear Regions	4
Region Spacing Increment (in)	4
Biaxial Column Method	Exact Integration
Parame Beta Factor (PCA)	.65
Concrete Stress Block	Rectangular
Use Cracked Sections?	Yes
Use Cracked Sections Slab?	No
Bad Framing Warnings?	No
Unused Force Warnings?	Yes
Min 1 Bar Diam. Spacing?	No
Concrete Rebar Set	REBAR SET ASTMA615
Min % Steel for Column	1
Max % Steel for Column	8

(Global) Model Settings, Continued

Seismic Code	ASCE 7-16
Seismic Base Elevation (in)	15600
Add Base Weight?	Yes
Ct X	.02
Ct Z	.02
T X (sec)	Not Entered
T Z (sec)	Not Entered
R X	3
R Z	3
Ct Exp. X	.75
Ct Exp. Z	.75
SD1	1
SDS	1
S1	1
TL (sec)	5
Risk Cat	I or II
Drift Cat	Other
Om Z	1
Om X	1
Cd Z	4
Cd X	4
Rho Z	1
Rho X	1

Hot Rolled Steel Properties

	Label	E [ksi]	G [ksi]	Nu	Therm (/1E5 F)	Density[lb/ft^3]	Yield[psi]	Ry	Fu[psi]	Rt
1	A992	29000	11154	.3	.65	490	50000	1.1	65000	1.1
2	A36 Gr.36	29000	11154	.3	.65	490	36000	1.5	58000	1.2
3	A572 Gr.50	29000	11154	.3	.65	490	50000	1.1	65000	1.1
4	A500 Gr.B R...	29000	11154	.3	.65	527	42000	1.4	58000	1.3
5	A500 Gr.B Re...	29000	11154	.3	.65	527	46000	1.4	58000	1.3
6	A53 Gr.B	29000	11154	.3	.65	490	35000	1.6	60000	1.2
7	A1085	29000	11154	.3	.65	490	50000	1.4	65000	1.3

Aluminum Properties

	Label	E [ksi]	G [ksi]	Nu	Therm (...Density[... Table B.4	kt	Ftu[psi]	Fty[psi]	Fcy[psi]	Fsu[psi]	Ct
1	3003-H14	10100	3787.5	.33	1.3 172.8 Table B.4-1	1	19000	16000	13000	12000	141
2	6061-T6	10100	3787.5	.33	1.3 172.8 Table B.4-2	1	38000	35000	35000	24000	141
3	6063-T5	10100	3787.5	.33	1.3 172.8 Table B.4-2	1	22000	16000	16000	13000	141
4	6063-T6	10100	3787.5	.33	1.3 172.8 Table B.4-2	1	30000	25000	25000	19000	141
5	5052-H34	10200	3787.5	.33	1.3 172.8 Table B.4-1	1	34000	26000	24000	20000	141
6	6061-T6 W	10100	3787.5	.33	1.3 172.8 Table B.4-1	1	24000	15000	15000	15000	141
7	6005-T5	10100	3787.5	.33	1.3 172.8 Table B.4-1	1	38000	35000	35000	24000	141

Hot Rolled Steel Section Sets

	Label	Shape	Type	Design List	Material	Design R...	A [in2]	Iyy [in4]	Izz [in4]	J [in4]
1	Post	Pipe 2.0 A21165	Column	Pipe	A572 Gr.50	Typical	.776	.499	.499	.998
2	Cross Beam	Pipe 2.5 A21168	Beam	Wide Flange	A572 Gr.50	Typical	.947	.907	.907	1.814
3	Diagonal Brace	1.5x1.5x0.083	Beam	Wide Flange	A36 Gr.36	Typical	.47	.158	.158	.236



Company : Vector Structural Engineering
 Designer : STB
 Job Number : U2716.094.191
 Model Name : Ground Mount

Apr 7, 2021
 5:11 PM
 Checked By: _____

Aluminum Section Sets

	Label	Shape	Type	Design List	Material	Design R...	A [in2]	Iyy [in4]	Izz [in4]	J [in4]
1	AL Posts	2.375ODX0.188	Column	Pipe	6005-T5	Typical	1.29	.778	.778	1.54
2	AL Brace	RT1.5x2x0.15625	VBrace	Rectangular Tubes	6005-T5	Typical	.996	.327	.524	.602
3	AL Rails	HR300	Beam	Rectangular Tubes	6005-T5	Typical	.74	.253	.727	.578
4	AL Cross Beam	Cross Rail	Beam	Rectangular Tubes	6005-T5	Typical	1.909	1.97	4.366	4.017

Member Area Loads (BLC 2 : Solar Panel Weight)

	Joint A	Joint B	Joint C	Joint D	Direction	Distribution	Magnitude[psf]
1	N197	N200	N199	N196	Y	A-B	-3

Member Area Loads (BLC 3 : Roof Live/Snow)

	Joint A	Joint B	Joint C	Joint D	Direction	Distribution	Magnitude[psf]
1	N197	N200	N199	N196	PY	A-B	-13

Member Area Loads (BLC 4 : Wind A 0 deg)

	Joint A	Joint B	Joint C	Joint D	Direction	Distribution	Magnitude[psf]
1	N197	N200	N201	N198	Perp	A-B	-31.2
2	N198	N201	N199	N196	Perp	A-B	-31.2

Member Area Loads (BLC 5 : Wind B 0 deg)

	Joint A	Joint B	Joint C	Joint D	Direction	Distribution	Magnitude[psf]
1	N197	N200	N201	N198	Perp	A-B	-43.3
2	N198	N201	N199	N196	Perp	A-B	-8.7

Member Area Loads (BLC 6 : Wind A 180 deg)

	Joint A	Joint B	Joint C	Joint D	Direction	Distribution	Magnitude[psf]
1	N197	N200	N201	N198	Perp	A-B	36.4
2	N198	N201	N199	N196	Perp	A-B	36.4

Member Area Loads (BLC 7 : Wind B 180 deg)

	Joint A	Joint B	Joint C	Joint D	Direction	Distribution	Magnitude[psf]
1	N197	N200	N201	N198	Perp	A-B	17.3
2	N198	N201	N199	N196	Perp	A-B	45.1

Member Area Loads (BLC 8 : Wind A 90)

	Joint A	Joint B	Joint C	Joint D	Direction	Distribution	Magnitude[psf]
1	N197	N203	N202	N196	Perp	A-B	13.9
2	N203	N209	N208	N202	Perp	A-B	10.4
3	N209	N200	N199	N208	Perp	A-B	5.2

Member Area Loads (BLC 9 : Wind B 90)

	Joint A	Joint B	Joint C	Joint D	Direction	Distribution	Magnitude[psf]
1	N197	N203	N202	N196	Perp	A-B	-13.9
2	N203	N209	N208	N202	Perp	A-B	-8.7
3	N209	N200	N199	N208	Perp	A-B	-5.2

Basic Load Cases

	BLC Description	Category	X Gravity	Y Gravity	Z Gravity	Joint	Point	Distributed	Area(M...Surface...
1	Self Weight	DL		-1.05					
2	Solar Panel Weight	DL							1



Envelope Joint Reactions (Continued)

Joint	X [lb]	LC	Y [lb]	LC	Z [lb]	LC	MX [lb-ft]	LC MY [lb-ft]	LC	MZ [lb-ft]	LC
14	min -5.817	11	-2697.922	16	-1445...	3	0	1	0	1	0
15	N122 max .96	19	1588.393	10	48.823	3	0	20	0	20	0
16	min -5.651	10	159.93	17	-58.169	5	0	1	0	1	0
17	N133B max 5.754	11	3193.413	5	1687.0...	5	0	20	0	20	0
18	min -5.609	16	-2697.688	16	-1445...	3	0	1	0	1	0
19	N134B max 5.645	10	1588.34	10	48.822	3	0	20	0	20	0
20	min -.065	20	159.98	17	-58.169	5	0	1	0	1	0
21	N137C max 152.972	16	2722.324	5	1353.0...	5	0	20	0	20	0
22	min -173.9...	11	-2278.308	16	-1158...	3	0	1	0	1	0
23	N138B max 29.189	15	1271.197	10	41.627	3	0	20	0	20	0
24	min -68.526	12	137.377	17	-49.398	5	0	1	0	1	0
25	Totals: max .066	8	22870.486	11	9345.4...	17					
26	min -.089	7	-11770.951	15	-8010...	3					

Envelope AISC 15th(360-16): ASD Steel Code Checks

Member	Shape	Code Check	Loc[in]	LC Shear	...	Loc[in]	Dir	LC Pnc/om	...	Pnt/om [lb]	Mny/om	Mnz/om	Cb	Eqn
1	M5	Pipe 2.0 A2...	.310	54.38	12	.209	54.38	5	16238.937	23232.186	1397.505	1397.505	1...	H1-1b
2	M6	Pipe 2.0 A2...	.760	36.903	11	.211	0	5	6510.563	23232.186	1397.505	1397.505	1...	H1-1a
3	M13	Pipe 2.5 A2...	.926	159....	12	.175	159....	6	9469.68	28358.413	2081.747	2081.747	1...	H1-1b
4	M14	Pipe 2.5 A2...	.708	161.25	11	.159	159....	11	11641.036	28358.413	2081.747	2081.747	2...	H1-1b
5	M15	1.5x1.5x0.083	.731	51.745	5	.094	101....	y 11	2310.341	10141.308	449.583	449.583	1...	H1-1a
6	M80	Pipe 2.0 A2...	.221	54.38	5	.265	54.38	5	16238.937	23232.186	1397.505	1397.505	1...	H1-1b
7	M81	Pipe 2.0 A2...	.829	3.355	5	.276	0	5	6510.563	23232.186	1397.505	1397.505	1...	H1-1a
8	M82	1.5x1.5x0.083	.962	51.745	5	.017	0	y 4	2310.341	10141.308	449.583	449.583	1...	H1-1a
9	M50	Pipe 2.0 A2...	.221	54.38	5	.265	54.38	5	16238.937	23232.186	1397.505	1397.505	1...	H1-1b
10	M51	Pipe 2.0 A2...	.829	3.355	5	.276	0	5	6510.563	23232.186	1397.505	1397.505	1...	H1-1a
11	M52	1.5x1.5x0.083	.962	51.745	5	.017	101....	y 4	2310.341	10141.308	449.583	449.583	1...	H1-1a
12	M56A	Pipe 2.0 A2...	.220	54.38	5	.247	54.38	5	16238.937	23232.186	1397.505	1397.505	1...	H1-1b
13	M57A	Pipe 2.0 A2...	.812	3.355	5	.260	0	5	6510.563	23232.186	1397.505	1397.505	1...	H1-1a
14	M58A	1.5x1.5x0.083	.903	51.745	5	.009	0	y 10	2310.341	10141.308	449.583	449.583	1...	H1-1a
15	M68	Pipe 2.0 A2...	.220	54.38	5	.247	54.38	5	16238.937	23232.186	1397.505	1397.505	1...	H1-1b
16	M69	Pipe 2.0 A2...	.812	3.355	5	.260	0	5	6510.563	23232.186	1397.505	1397.505	1...	H1-1a
17	M70	1.5x1.5x0.083	.903	51.745	5	.009	101....	y 10	2310.341	10141.308	449.583	449.583	1...	H1-1a
18	M68A	Pipe 2.5 A2...	.912	99.375	12	.177	99.375	12	11641.036	28358.413	2081.747	2081.747	1...	H1-1b
19	M69A	Pipe 2.5 A2...	.961	160	12	.177	40	12	11641.036	28358.413	2081.747	2081.747	1...	H1-1b
20	M70A	Pipe 2.5 A2...	.831	99.375	11	.193	99.375	11	11641.036	28358.413	2081.747	2081.747	2...	H1-1b
21	M71	Pipe 2.5 A2...	.869	40	11	.193	40	11	11641.036	28358.413	2081.747	2081.747	1...	H1-1b
22	M66A	Pipe 2.0 A2...	.310	54.38	12	.209	54.38	5	16238.937	23232.186	1397.505	1397.505	1...	H1-1b
23	M67A	Pipe 2.0 A2...	.760	36.903	11	.211	0	5	6510.563	23232.186	1397.505	1397.505	1...	H1-1a
24	M68C	1.5x1.5x0.083	.731	51.745	5	.094	0	y 11	2310.341	10141.308	449.583	449.583	1...	H1-1a

Envelope AA ADM1-15: ASD - Building Aluminum Code Checks

Member	Shape	Code C...	Loc[in]	LC Shear	...	Loc[in]	Dir	LC Pnc/O...	Pnt/Om...	Mny/O...	Mnz/O...	Vny/O...	Vnz/O...	Cb	Eqn	
1	M19	RT1.5x2x...	.276	47.437	11	.029	0	z 5	2630.847	19411....	770.742	927.083	5889.423	3966.346	1...	H.1-1
2	M16	HR300	.624	41.532	12	.083	43.419	y 11	6408.62	14429....	560.361	934.132	5656.689	2605.145	2...	H.1-1
3	M69C	RT1.5x2x...	.275	47.508	11	.029	0	z 5	2622.988	19411....	770.742	927.083	5889.423	3966.346	1...	H.1-1
4	M32	HR300	.740	41.532	6	.105	43.419	y 12	6408.62	14429....	560.361	934.132	5656.689	2605.145	1...	H.1-1
5	M35	HR300	.687	41.532	12	.084	43.419	y 12	6408.62	14429....	560.361	934.132	5656.689	2605.145	2...	H.1-1
6	M38	HR300	.699	143.4...	16	.089	43.419	y 12	3613.768	14429....	560.361	934.132	5656.689	2605.145	1...	H.1-1
7	M41	HR300	.688	41.532	12	.084	43.419	y 12	6408.62	14429....	560.361	934.132	5656.689	2605.145	2...	H.1-1
8	M44	HR300	.688	41.532	12	.081	43.419	y 12	6408.62	14429....	560.361	934.132	5656.689	2605.145	2...	H.1-1
9	M47	HR300	.742	143.4...	16	.079	43.419	y 12	3613.768	14429....	560.361	934.132	5656.689	2605.145	1...	H.1-1
10	M50A	HR300	.688	41.532	12	.085	43.419	y 12	6408.62	14429....	560.361	934.132	5656.689	2605.145	2...	H.1-1
11	M53	HR300	.688	41.532	12	.085	43.419	y 12	6408.62	14429....	560.361	934.132	5656.689	2605.145	2...	H.1-1



Company : Vector Structural Engineering
 Designer : STB
 Job Number : U2716.094.191
 Model Name : Ground Mount

Apr 7, 2021
 5:11 PM
 Checked By: _____

Envelope AA ADM1-15: ASD - Building Aluminum Code Checks (Continued)

Member	Shape	Code C...	Loc[fin]	LC Shear ...	Loc[fin]	Dir	LC Pnc/O...	Pnt/Om...	Mny/O...	Mnz/O...	Vny/O...	Vnz/O...	Cb Eqn			
12	M56	HR300	.742	143.4...	16	.079	43.419	y	12	3613.768	14429....	560.361	934.132	5656.689	2605.145	1...H.1-1
13	M59	HR300	.688	41.532	12	.081	43.419	y	12	6408.62	14429....	560.361	934.132	5656.689	2605.145	2...H.1-1
14	M62	HR300	.688	41.532	12	.084	43.419	y	12	6408.62	14429....	560.361	934.132	5656.689	2605.145	2...H.1-1
15	M65	HR300	.699	143.4...	16	.089	43.419	y	12	3613.768	14429....	560.361	934.132	5656.689	2605.145	1...H.1-1
16	M68B	HR300	.687	41.532	12	.084	43.419	y	12	6408.62	14429....	560.361	934.132	5656.689	2605.145	2...H.1-1
17	M71A	HR300	.740	41.532	6	.105	43.419	y	12	6408.62	14429....	560.361	934.132	5656.689	2605.145	2...H.1-1
18	M74	HR300	.624	41.532	12	.082	43.419	y	11	6408.62	14429....	560.361	934.132	5656.689	2605.145	2...H.1-1

NOTES: UNLESS OTHERWISE SPECIFIED
 1. DIMENSIONS SHOWN ARE INCHES [MILLIMETERS].

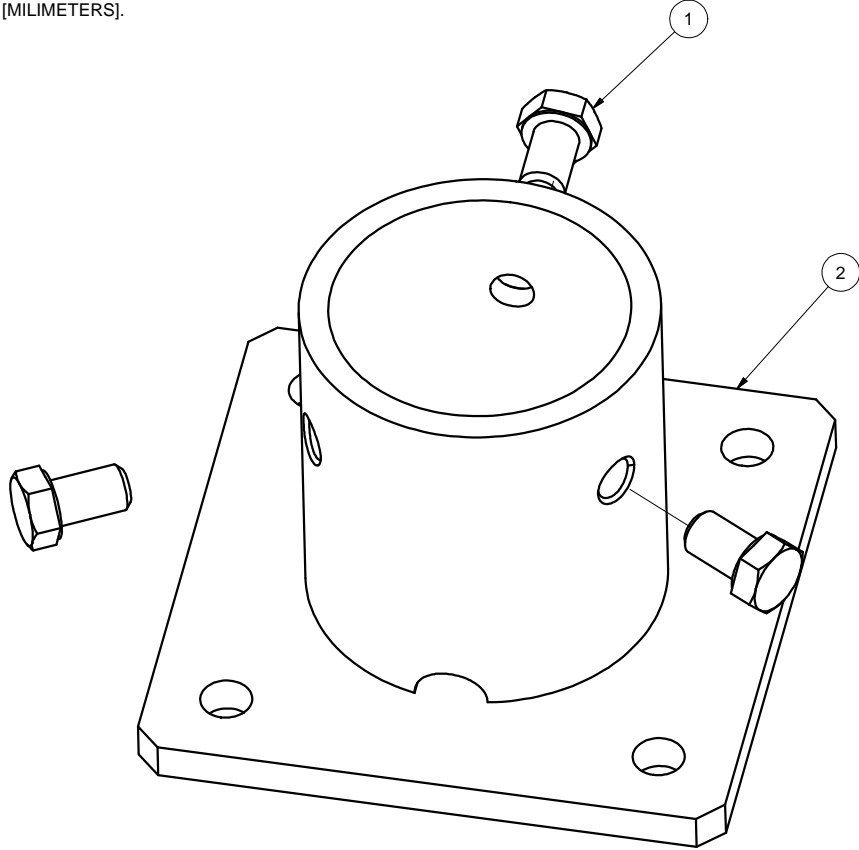

REVISIONS			
REV	DESCRIPTION	BY	DATE
A	INITIAL RELEASE	LWF	10/20/2016

2	A21120-001	2" PIPE BASE	1
1	B15018-011	HEX CAP SCREW 3/8-16 X 5/8	3
ITEM	PART NUMBER	DESCRIPTION	QTY
MATERIAL		SEE NOTES	
Third Angle Projection:			
GENERAL SPECIFICATIONS		Sunmodo Corp. 1905 E 5TH STREET, STE A, VANCOUVER, WA 98661	
Tolerances		TITLE	
X.XXX ±0.01 [0.25mm]		2" PIPE BASE KIT	
X.XX ±0.02 [0.50mm]		DRAWING NUMBER	
X.X ±0.039 [1.0mm]		B K10268-001	
Unless otherwise spec'd		SCALE: NONE	
DRAWN BY		SHEET 1 of 1	
LWF		DATE	
CHECKED BY		10/20/2016	
APPROVALS			

THIS DRAWING IS CONFIDENTIAL PROPERTY OF SUNMODO AND ITS CONTENTS MAY NOT BE DISCLOSED WITHOUT THE PRIOR WRITTEN CONSENT OF SUNMODO CORP.

REVISIONS			
REV	DESCRIPTION	BY	DATE
A	ADDED BOTTOM CHANNEL & CHANGED ONE 3/8 CHANNEL TO 1/4	zcg	02/21/2013

NOTES: UNLESS OTHERWISE SPECIFIED

1. DIMENSIONS SHOWN ARE INCHES [MILIMETERS].
2. MATERAIL: ALUMINUM 6005-T5.
FINISH: CLEAR ANODIZED 15 μ m THICK.
3. THE UNSPECIFIED DIMENSIONS ARE SPECIFIED BY 2D CAD FILE.

2X 1/4 BOLT SLOT

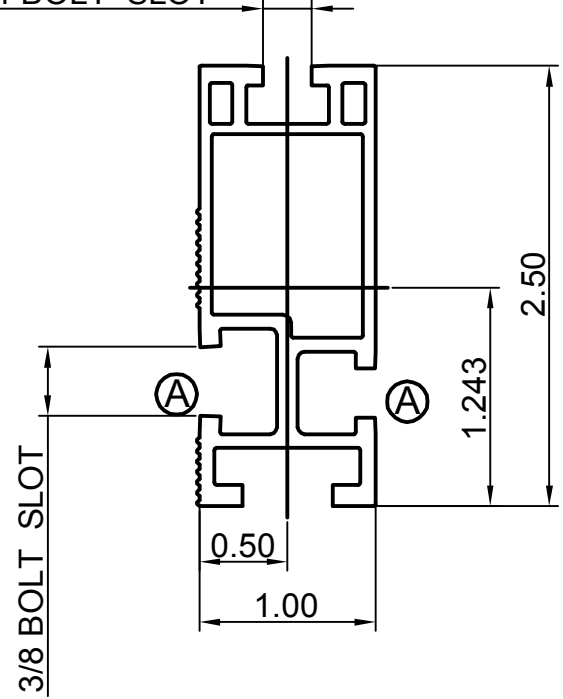

Section properties:

Weight: 0.850 lbs/ft
 Area: 0.723 in²
 Perimeter: 17.325 in
 Bounding Box: X: -0.500,0.500
 Y: -1.243,1.257

Centroid:(0.000,0.000)
 Moments of Incertia(in⁴): Ix=0.486,Iy=0.095
 Section modulus in bending(in³): Wx=0.387,Wy=0.190
 Radii of Gyration: X: 0.820, Y: 0.363

MATERIAL SEE NOTES		Sunmodo Corp.	
Third Angle Projection:			
GENERAL SPECIFICATIONS All Dimensions in inches [millimeters]		1905 E 5TH STREET, SUITE A, VANCOUVER, WA 98661	
Tolerances: X.XXX ± 0.01 [0.25mm] X.XX ± 0.02 [0.50mm] X.X ± 0.039 [1.0mm] Unless otherwise spec'd		TITLE HELIO STANDARD RAIL	
DRAWN BY zcg	DATE 02/21/2013	DRAWING NUMBER A20144	
CHECKED BY		SCALE: NONE SHEET 1 of 1	
APPROVALS			

4

3

2

1

NOTES: UNLESS OTHERWISE SPECIFIED

- 1. DIMENSIONS SHOWN ARE INCHES [MILIMETERS].
- 2. MATERIAL: 6005-T5.
FINISH: CLEAR ANODIZED 10um THICK.
- 3. THE UNSPECIFIED RADII ARE .02" MAX.
- 4. THE UNSPECIFIED DIMENSIONS ARE SPECIFIED BY 2D CAD FILE.

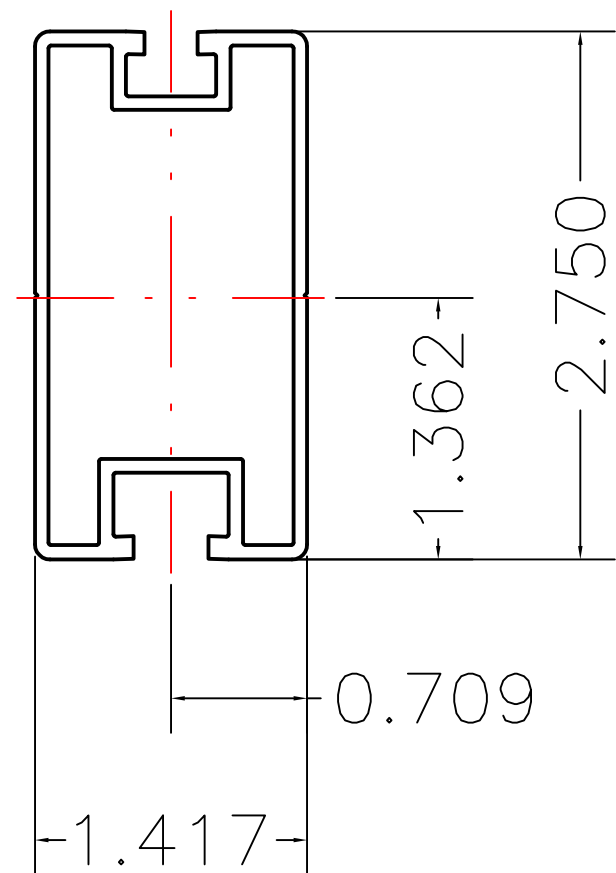

Section properties:

Weight: 0.862 lbs/ft
 Area: 0.736 in²
 Perimeter: 19.824 in
 Bounding Box: X: -0.709,0.709
 Y: -1.362,1.388
 Centroid:(0.000,0.000)
 Moments of Inertia(in⁴): I_x=0.727,I_y=0.214
 Section modulus in bending(in³): W_x=0.524,W_y=0.302
 Radii of Gyration: X: 994, Y: 0.539

MATERIAL SEE NOTES	
Third Angle Projection:	
GENERAL SPECIFICATIONS All Dimensions in inches [millimeters]	
Tolerances	
X.XXX ±0.01 [0.25mm]	Break all sharp edges .010-.020 unless otherwise specified.
X.XX ±0.02 [0.50mm]	
X.X ±0.039 [1.0mm]	
Unless otherwise spec'd	
DRAWN BY KYY	DATE 01/18/2018
CHECKED BY	
APPROVALS	

SunModo Corp.	
14800 NE 65TH STREET, VANCOUVER WA 98682	
TITLE RAIL, HR300 (SUNRAY), EXTRUSION	
B	DRAWING NUMBER A20288
SCALE: NONE	SHEET 1 of 1

THIS DRAWING IS CONFIDENTIAL PROPERTY OF SUNMODO AND ITS CONTENTS MAY NOT BE DISCLOSED WITHOUT THE PRIOR WRITTEN CONSENT OF SUNMODO CORP.

REV	DESCRIPTON	BY	DATE
A	0.44 WAS 0.41, 0.44 WAS 0.33	LWF	11/30/2015

NOTES: UNLESS OTHERWISE SPECIFIED

1. DIMENSIONS SHOWN ARE INCHES [MILIMETERS].
2. MATERAIL: ALUMINUM 6005-T5.
FINISH: CLEAR ANODIZED 15 μm THICK.
3. THE UNSPECIFIED DIMENSIONS ARE SPECIFIED BY 2D CAD FILE.

2X 1/4 BOLT SLOT

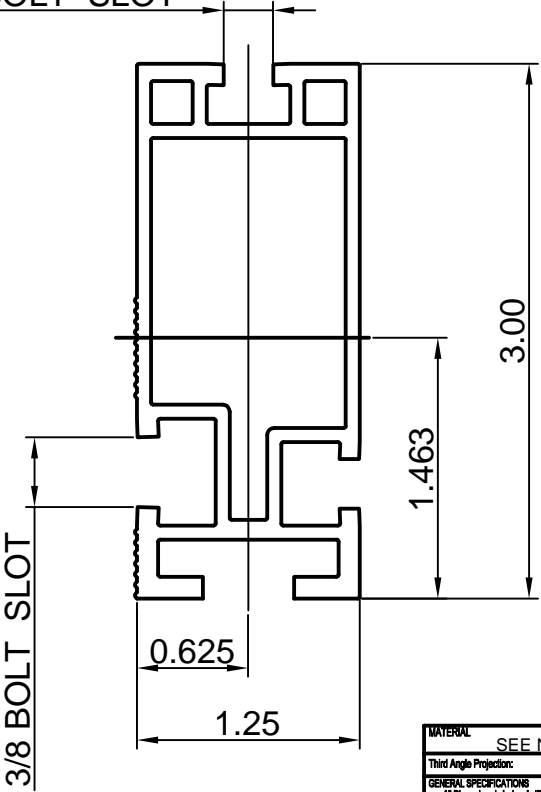

Section properties:

Weight: 1.151 lbs/ft
 Area: 0.980 in²
 Perimeter: 22.104 in
 Bounding Box: X: -0.625,0.625
 Y: -1.463,1.537
 Centroid:(0.000,0.000)
 Moments of Inertia(in⁴): Ix=1.047,Iy=0.207
 Section modulus in bending(in³): Wx=0.681,Wy=0.331
 Radii of Gyration: X: 1.034, Y: 0.460

MATERIAL		SEE NOTES	
Third Angle Projection			
GENERAL SPECIFICATIONS			
All Dimensions in Inches (millimeters)			
Tolerances			
XXX ±0.01 (0.25mm)			
XX ±0.02 (0.50mm)			
X ±0.03 (1.0mm)			
Unless otherwise specified.			
Break all sharp edges 0.10-0.25 unless otherwise specified.			
DRAWN BY		DATE	
ZCJ		02/21/2013	
CHECKED BY		B	
APPROVALS		DRAWING NUMBER	
		A20145	
SCALE:		SHEET	
NONE		1 of 1	

Sunmodo Corp.

1905 E 5TH STREET, SUITE A, VANCOUVER, WA 98661

TITLE
HELIO HEAVY RAIL

B DRAWING NUMBER
A20145

SCALE: NONE SHEET 1 of 1

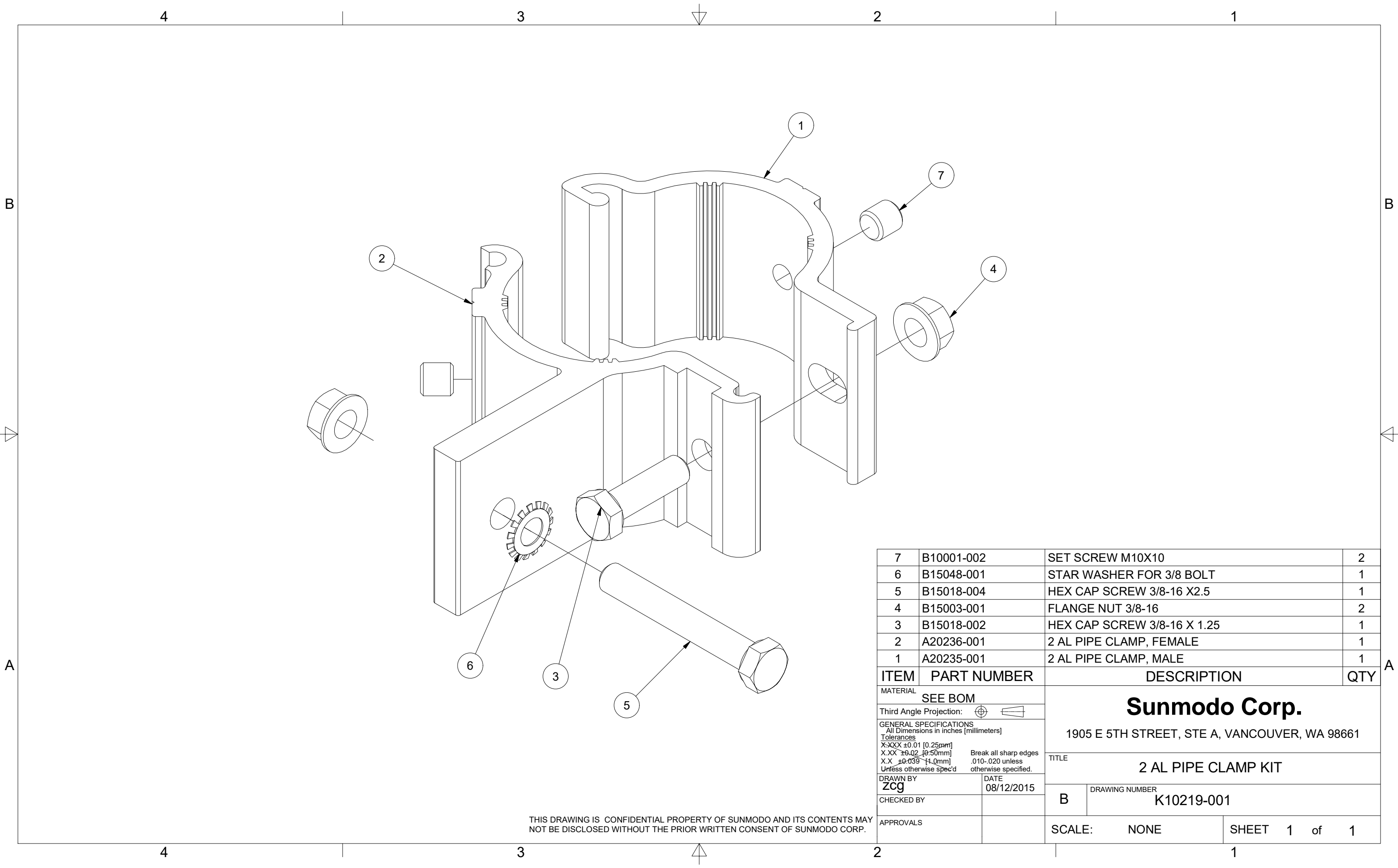

7	B10001-002	SET SCREW M10X10	2
6	B15048-001	STAR WASHER FOR 3/8 BOLT	1
5	B15018-004	HEX CAP SCREW 3/8-16 X2.5	1
4	B15003-001	FLANGE NUT 3/8-16	2
3	B15018-002	HEX CAP SCREW 3/8-16 X 1.25	1
2	A20236-001	2 AL PIPE CLAMP, FEMALE	1
1	A20235-001	2 AL PIPE CLAMP, MALE	1

ITEM	PART NUMBER	DESCRIPTION	QTY
MATERIAL		SEE BOM	
Third Angle Projection:			
GENERAL SPECIFICATIONS All Dimensions in inches (millimeters)			
Tolerances			
X.XXX ±0.01 [0.25mm]		Break all sharp edges	
X.XX ±0.02 [0.50mm]		.010-.020 unless	
X.X ±0.039 [1.0mm]		otherwise specified.	
DRAWN BY		DATE	
zcg		08/12/2015	
CHECKED BY		TITLE	
		2 AL PIPE CLAMP KIT	
APPROVALS		DRAWING NUMBER	
		B K10219-001	
SCALE:		NONE	SHEET 1 of 1

THIS DRAWING IS CONFIDENTIAL PROPERTY OF SUNMODO AND ITS CONTENTS MAY NOT BE DISCLOSED WITHOUT THE PRIOR WRITTEN CONSENT OF SUNMODO CORP.

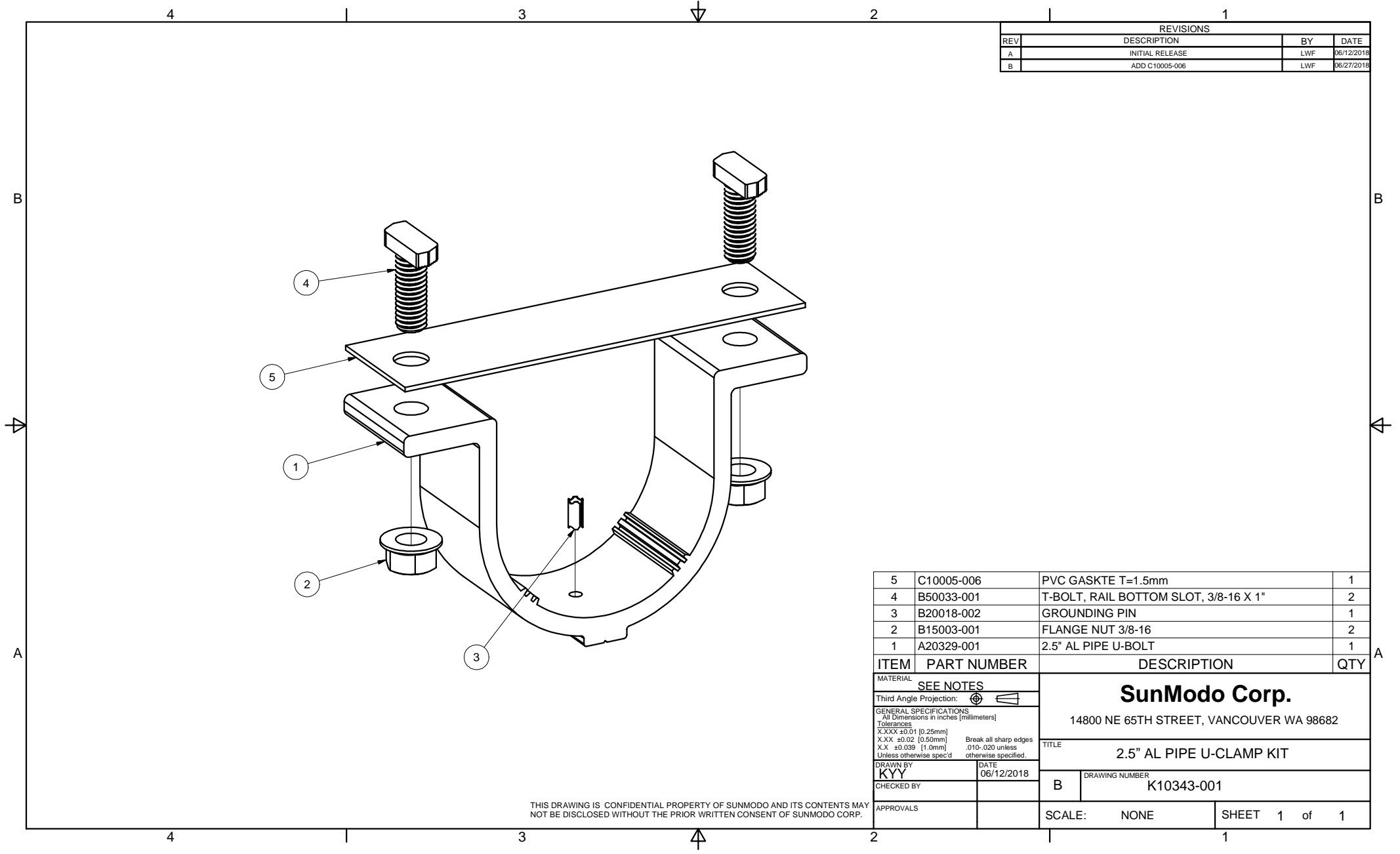

REVISIONS			
REV	DESCRIPTION	BY	DATE
A	INITIAL RELEASE	LWF	06/12/2018
B	ADD C10005-006	LWF	06/27/2018

ITEM	PART NUMBER	DESCRIPTION	QTY
5	C10005-006	PVC GASKTE T=1.5mm	1
4	B50033-001	T-BOLT, RAIL BOTTOM SLOT, 3/8-16 X 1"	2
3	B20018-002	GROUNDING PIN	1
2	B15003-001	FLANGE NUT 3/8-16	2
1	A20329-001	2.5" AL PIPE U-BOLT	1

MATERIAL		SEE NOTES	
Third Angle Projection:			
GENERAL SPECIFICATIONS		SunModo Corp. 14800 NE 65TH STREET, VANCOUVER WA 98682	
Tolerances		TITLE	
X.XXX ±0.01 [0.25mm] X.XX ±0.02 [0.50mm] X.X ±0.039 [1.0mm] Unless otherwise spec'd		2.5" AL PIPE U-CLAMP KIT	
Break all sharp edges .010-.020 unless otherwise specified.		DRAWING NUMBER	
DRAWN BY	DATE	B K10343-001	
KYY	06/12/2018		
CHECKED BY			
APPROVALS		SCALE: NONE	SHEET 1 of 1

THIS DRAWING IS CONFIDENTIAL PROPERTY OF SUNMODO AND ITS CONTENTS MAY NOT BE DISCLOSED WITHOUT THE PRIOR WRITTEN CONSENT OF SUNMODO CORP.

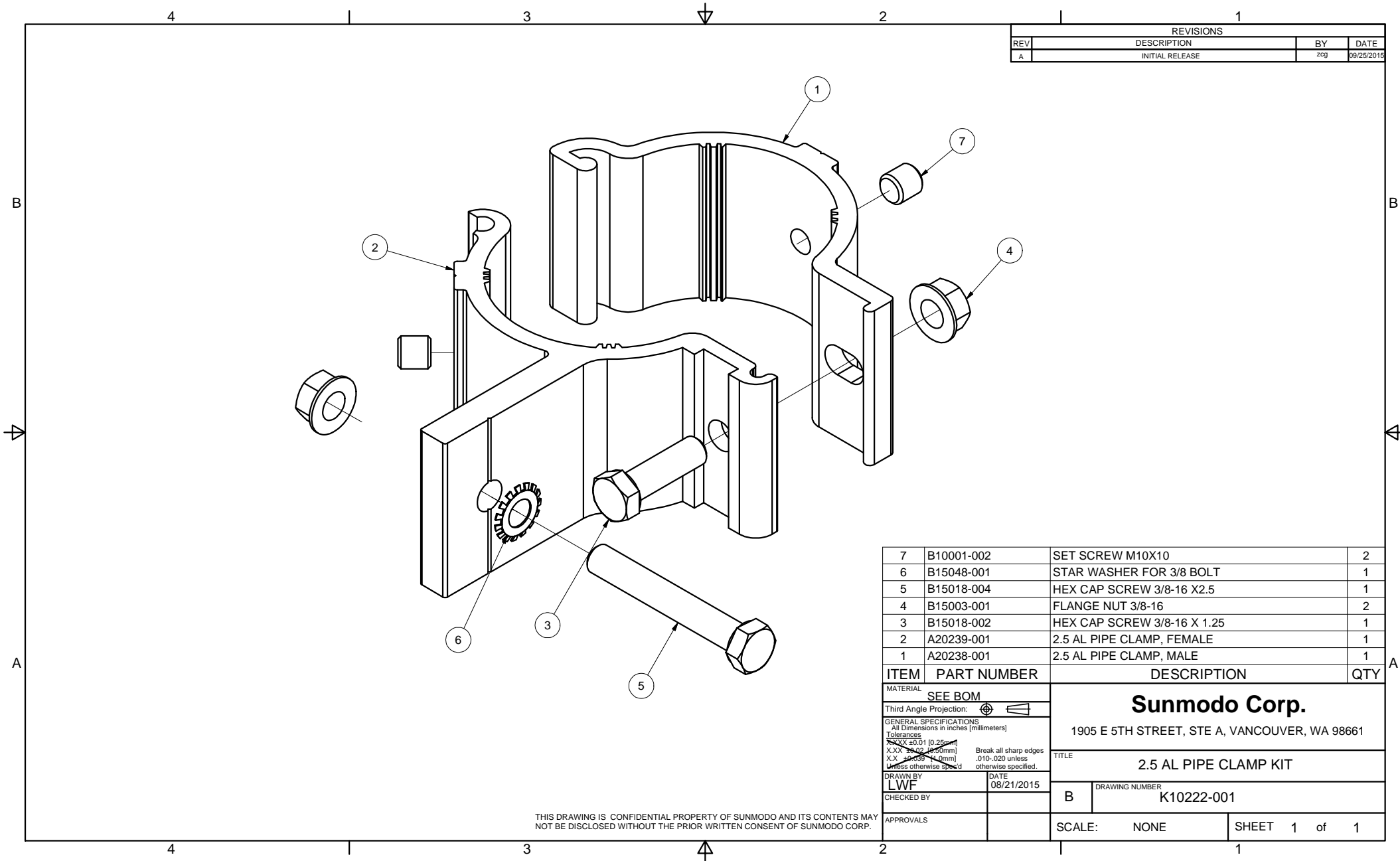

REVISIONS			
REV	DESCRIPTION	BY	DATE
A	INITIAL RELEASE	zcg	09/25/2015

ITEM	PART NUMBER	DESCRIPTION	QTY
7	B10001-002	SET SCREW M10X10	2
6	B15048-001	STAR WASHER FOR 3/8 BOLT	1
5	B15018-004	HEX CAP SCREW 3/8-16 X2.5	1
4	B15003-001	FLANGE NUT 3/8-16	2
3	B15018-002	HEX CAP SCREW 3/8-16 X 1.25	1
2	A20239-001	2.5 AL PIPE CLAMP, FEMALE	1
1	A20238-001	2.5 AL PIPE CLAMP, MALE	1

MATERIAL		SEE BOM	
Third Angle Projection:			
GENERAL SPECIFICATIONS All Dimensions in inches [millimeters] Tolerances X.XX ±0.01 [0.25mm] X.X ±0.02 [0.5mm] X.X ±0.03 [0.75mm] Unless otherwise specified, Break all sharp edges .010-.020 unless otherwise specified.			
DRAWN BY	DATE	TITLE	
LWF	08/21/2015	2.5 AL PIPE CLAMP KIT	
CHECKED BY		DRAWING NUMBER	
		B	K10222-001
APPROVALS		SCALE:	NONE
		SHEET	1 of 1

THIS DRAWING IS CONFIDENTIAL PROPERTY OF SUNMODO AND ITS CONTENTS MAY NOT BE DISCLOSED WITHOUT THE PRIOR WRITTEN CONSENT OF SUNMODO CORP.

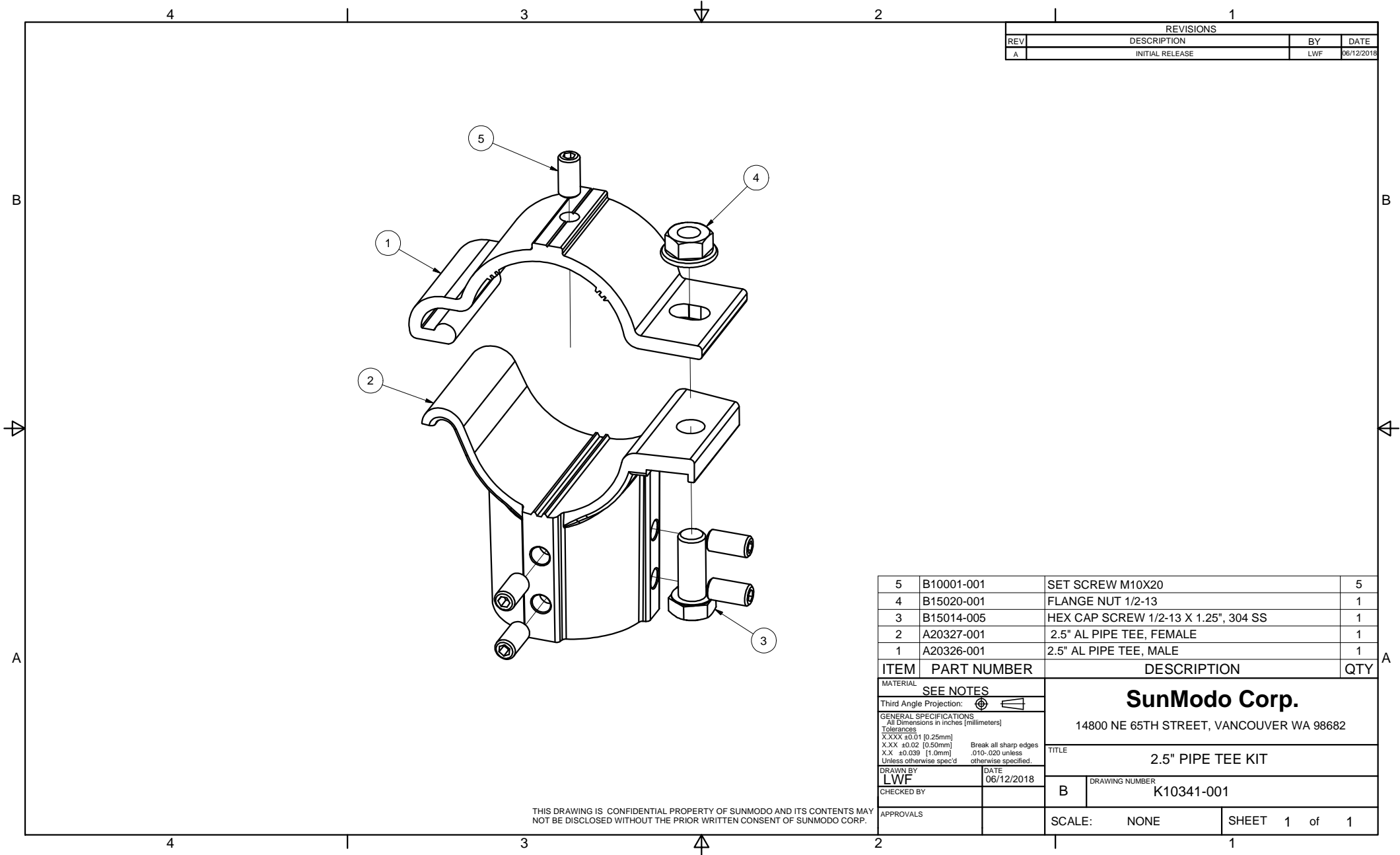

REVISIONS			
REV	DESCRIPTION	BY	DATE
A	INITIAL RELEASE	LWF	06/12/2018

ITEM	PART NUMBER	DESCRIPTION	QTY
5	B10001-001	SET SCREW M10X20	5
4	B15020-001	FLANGE NUT 1/2-13	1
3	B15014-005	HEX CAP SCREW 1/2-13 X 1.25", 304 SS	1
2	A20327-001	2.5" AL PIPE TEE, FEMALE	1
1	A20326-001	2.5" AL PIPE TEE, MALE	1

MATERIAL		SEE NOTES	
Third Angle Projection:			
GENERAL SPECIFICATIONS		SunModo Corp. 14800 NE 65TH STREET, VANCOUVER WA 98682	
Tolerances		TITLE	
X.XXX ±0.01 [0.25mm] X.XX ±0.02 [0.50mm] X.X ±0.039 [1.0mm] Unless otherwise spec'd		2.5" PIPE TEE KIT	
DRAWN BY		DATE	
LWF		06/12/2018	
CHECKED BY		DRAWING NUMBER	
		B K10341-001	
APPROVALS		SCALE: NONE SHEET 1 of 1	

THIS DRAWING IS CONFIDENTIAL PROPERTY OF SUNMODO AND ITS CONTENTS MAY NOT BE DISCLOSED WITHOUT THE PRIOR WRITTEN CONSENT OF SUNMODO CORP.

REVISIONS			
REV	DESCRIPTION	BY	DATE
A	INITIAL RELEASE	LWF	06/12/2018

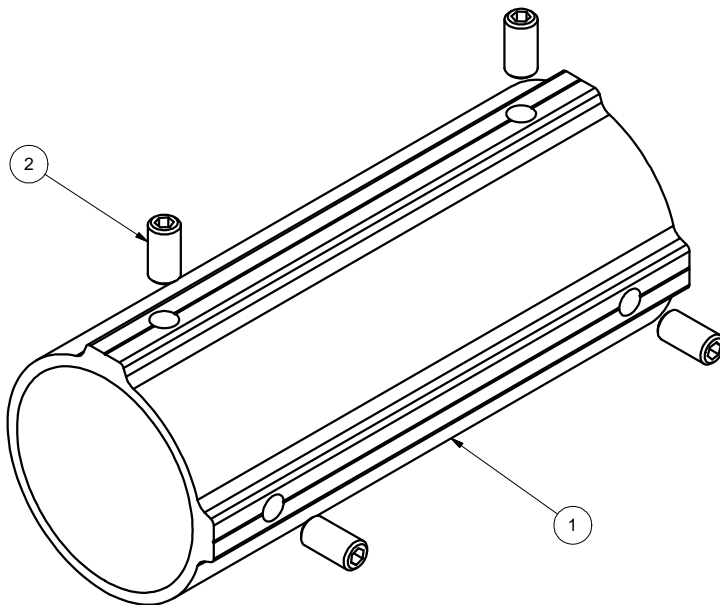

2	B10001-001	SET SCREW M10X20	4
1	A20328-001	2.5" PIPE SPLICE	1
ITEM	PART NUMBER	DESCRIPTION	QTY
MATERIAL		SEE NOTES	
Third Angle Projection:			
GENERAL SPECIFICATIONS		SunModo Corp. 14800 NE 65TH STREET, VANCOUVER WA 98682	
All Dimensions in inches [millimeters] Tolerances X.XXX ±0.01 [0.25mm] X.XX ±0.02 [0.50mm] X.X ±0.039 [1.0mm] Unless otherwise spec'd		Break all sharp edges .010-.020 unless otherwise specified.	
DRAWN BY		TITLE	
LWF		2.5" PIPE SPLICE KIT	
DATE		DRAWING NUMBER	
06/12/2018		B K10342-001	
CHECKED BY		SCALE: NONE	
APPROVALS		SHEET 1 of 1	

THIS DRAWING IS CONFIDENTIAL PROPERTY OF SUNMODO AND ITS CONTENTS MAY NOT BE DISCLOSED WITHOUT THE PRIOR WRITTEN CONSENT OF SUNMODO CORP.

NOTES: UNLESS OTHERWISE SPECIFIED

1. DIMENSIONS SHOWN ARE INCHES [MILIMETERS].
2. MATERIAL:HIGH STRENGTH STEEL PIPE OR TUBE.
3. FINISH: HOT DIP GALVANIZE PER ASTM A123 / A123M - 02.

MINIMUM 50 KSI YIELD STRESS.

4. BREAK ALL BURRS AND SHARP EDGES.

5. ALL WELDING MUST BE IN COMPLIANCE WITH AWS CODE D1;1.

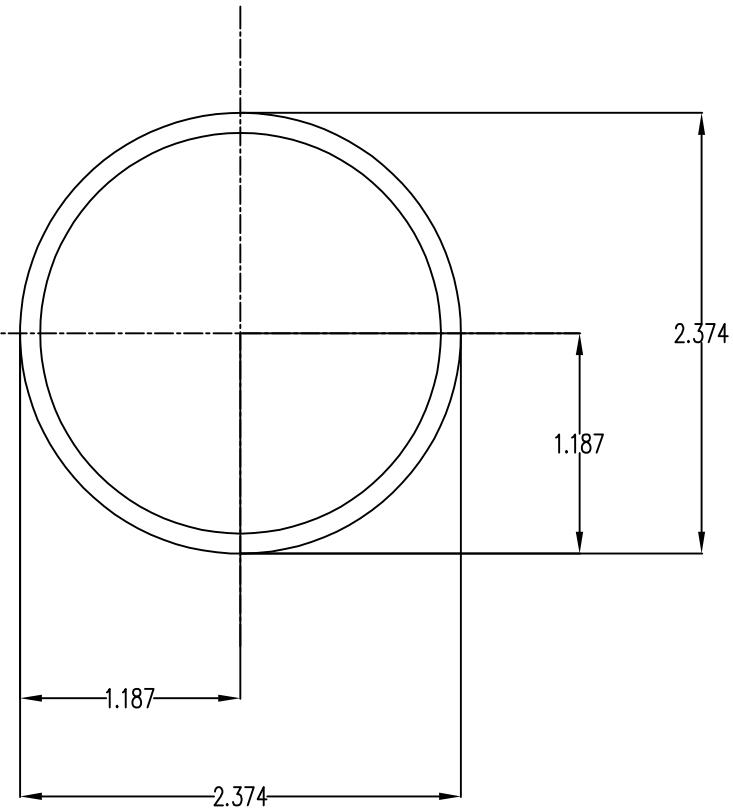

Section properties:

Weight: 2.641 lbs/ft

Area: 0.776 in²

Perimeter: 14.238 in

Bounding Box: X: -1.187,1.187

Y: -1.187,1.187

Centroid:(0.000,0.000)

Moments of Inertia(in⁴): Ix=0.499,Iy=0.499

Section modulus in bending(in³): Wx=0.420,Wy=0.420

Radii of Gyration: X: 0.802, Y: 0.802

MATERIAL		SEE NOTES		Sunmodo Corp. 14800 NE 85TH STREET, VANCOUVER WA 98682	
Third Angle Projection:					
GENERAL SPECIFICATIONS				TITLE	
All Dimensions in Inches (millimeters)				PIPE, HSS, 2.375" OD X 12 GAUGE,L=XXX	
Tolerances				Break all sharp edges .010-.020 unless otherwise specified.	
XXX ±0.01 (0.25mm)					
XX ±0.02 (0.50mm)					
X ±0.050 (1.2mm)					
Unless otherwise specified					
DRAWN BY	DATE	B		DRAWING NUMBER	
LWF	04/03/2019			A21165	
CHECKED BY					
APPROVALS				SCALE: NONE SHEET 1 of 1	

NOTES: UNLESS OTHERWISE SPECIFIED

1. DIMENSIONS SHOWN ARE INCHES [MILIMETERS].
2. MATERAIL:HIGH STRENGTH STEEL PIPE OR TUBE.
3. FINISH: HOT DIP GALVANIZE PER ASTM A123 / A123M - 02.

MINIMUM 50 KSI YIELD STRESS.

4. BREAK ALL BURRS AND SHARP EDGES.
5. ALL WELDING MUST BE IN COMPLIANCE WITH AWS CODE D1;1.

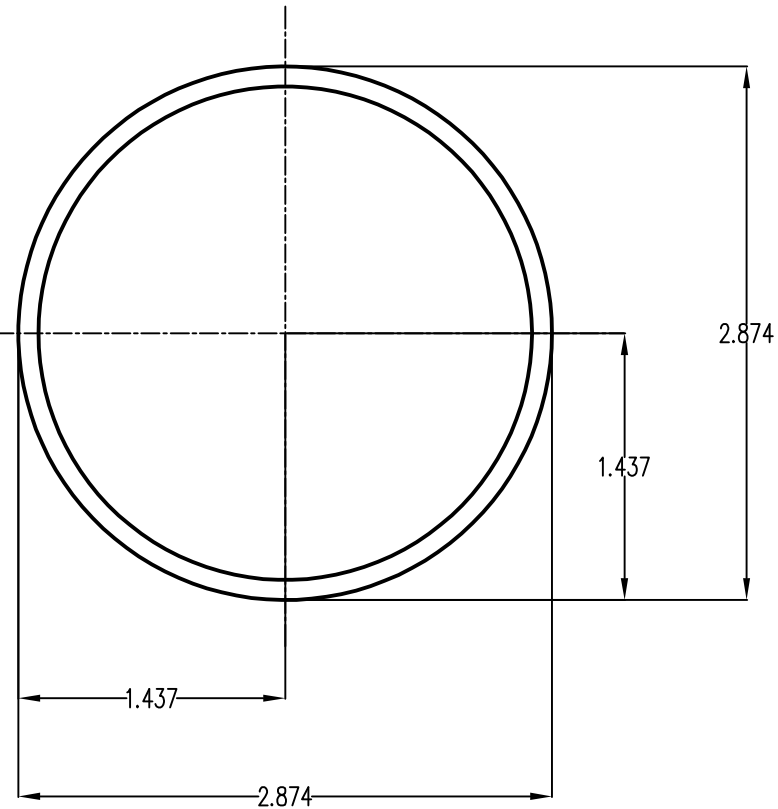

Section properties:

Weight: 3.201 lbs/ft

Area: 0.941 in²

Perimeter: 17.378 in

Bounding Box: X: -1.437,1.437

Y: -1.437,1.437

Centroid:(0.000,0.000)

Moments of Inertia(in⁴): Ix=0.901,Iy=0.901

Section modulus in bending(in³): Wx=0.627,Wy=0.627

Radii of Gyration: X: 0.979, Y: 0.979

MATERIAL		SEE NOTES		Sunmodo Corp.	
Third Angle Projection:					
GENERAL SPECIFICATIONS				14800 NE 85TH STREET, VANCOUVER WA 98682	
All Dimensions in Inches (millimeters)				TITLE	
Tolerances				PIPE, HSS, 2.875" OD X 12 GAUGE,L=XXX	
XXX ±0.01 (0.25mm)				Break all sharp edges .010-.020 unless otherwise specified.	
XX ±0.02 (0.50mm)				DRAWING NUMBER	
X ±0.005 (0.125mm)				B A21168	
Unless otherwise specified				APPROVALS	
DRAWN BY		DATE		SCALE: NONE	
LWF		04/03/2019		SHEET 1 of 1	
CHECKED BY					