



Project Number: U2716-091-191

November 11, 2020

Sunmodo  
14800 NE 65<sup>th</sup> Street  
Vancouver, WA 98682

**REFERENCE: Sunmodo Sunturf Ground Mount A1  
Ground Mount PV Array Installation**

To Whom It May Concern:

Per request of Sunmodo, we have been asked to prepare the structural design of a ground-mounted PV solar array system with several foundation options as shown in the attached calculations. The adopted building code in this jurisdiction is the International Building Code, 2015 Edition. Vector Structural Engineering requires that we review each site specific install, and we are not liable for installs at site specific locations we have not reviewed. The following design parameters are used in our analysis:

- Minimum Design Loads for Buildings and Other Structures (ASCE 7-10)
- Design wind speed for risk category I structures: 135 mph
- Wind exposure: C
- Ground snow load: 60 psf
- The ground screws and helical piers must be tested to 1.5 times uplift and 2.0 times lateral reactions found in the table below. A minimum of one ground screw or helical pier must be tested.

Load (ASD)	Value (lbs)	Factor of Safety	Test Value (lbs)
UPLIFT	2850	1.5	4275
LATERAL	2000	2	4000

Foundation concrete shall have a minimum compressive strength of 2500 psi at 28 days. Cement for all concrete shall be Type I or II with a minimum of 6% entrained air with a water/cement ratio of 0.50. Maximum aggregate size shall be 3/4". No special inspection of concrete strength is required.

Footings are designed based on an allowable soil bearing pressure of 1500 psf an allowable skin friction of 250 psf, an allowable lateral bearing pressure of 150 pcf, and a coefficient of friction of 0.3. Vector Structural Engineering strongly recommends independent soils testing be performed by a licensed geotechnical engineer to verify the assumed soil parameters.

All ground mounts are to be installed per manufacturer’s recommendations. The use of solar panel support span tables provided by the manufacturer is allowed only where the site conditions and solar panel configuration match the description of the span tables. Electrical engineering is beyond our scope. All work performed must be in accordance with accepted industry-wide methods and applicable safety standards. Vector Structural Engineering assumes no responsibility for improper installation of the solar panels.

Very truly yours,

VECTOR STRUCTURAL ENGINEERING, LLC  
CO Firm License: 20181009799

Kelly Springer, P.E.  
License: 56677 - Expires: 10/31/2021  
Project Engineer

Enclosures

KGS/stb





JOB NO. U2716-091-191  
 PROJECT SUNMODO SUNTURF GROUND MOUNTS A1  
 SUBJECT ALL OPTIONS

651 W GALENA PARK BLVD. #101 (801) 990-1775  
 DRAPER, UTAH 84020 (801) 990-1776 FAX

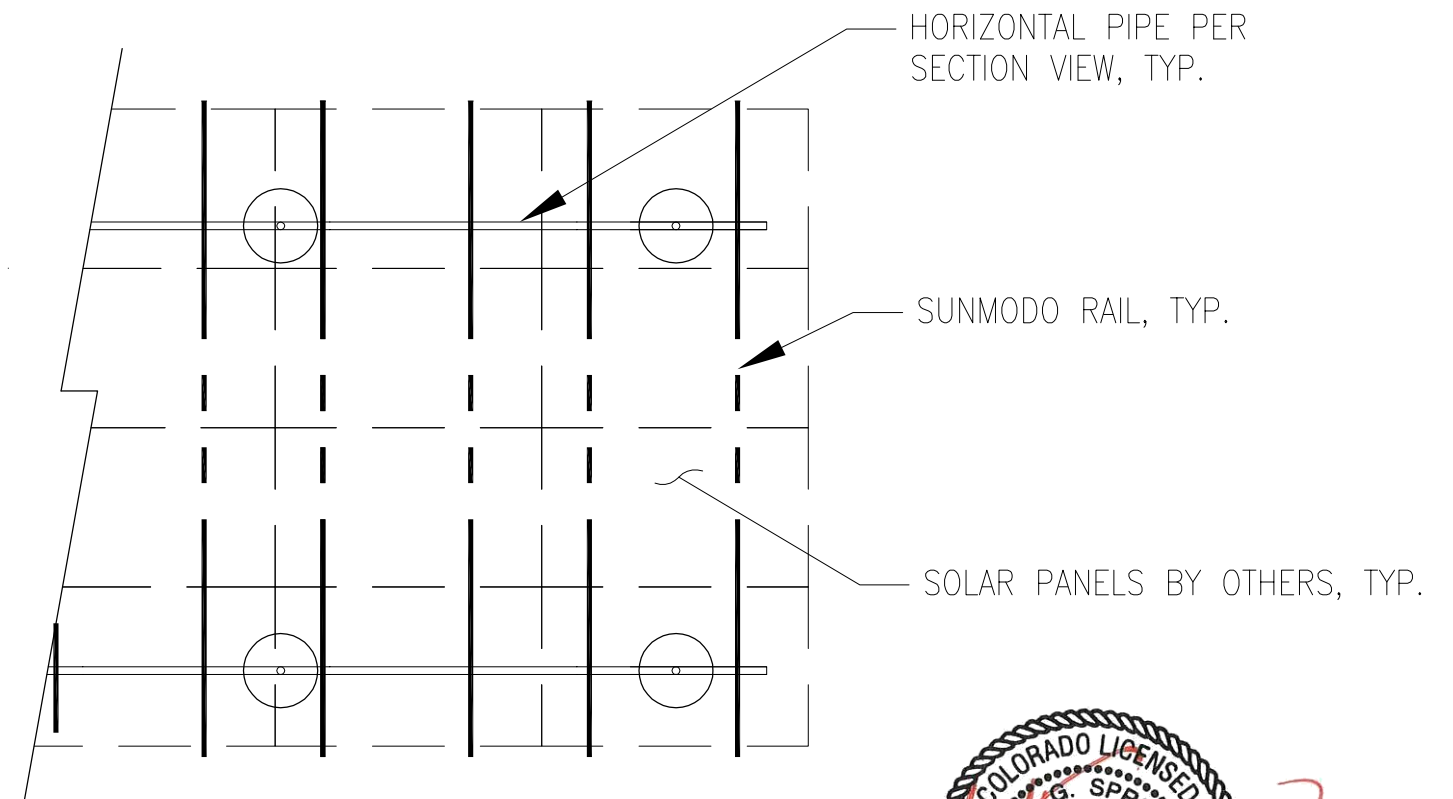
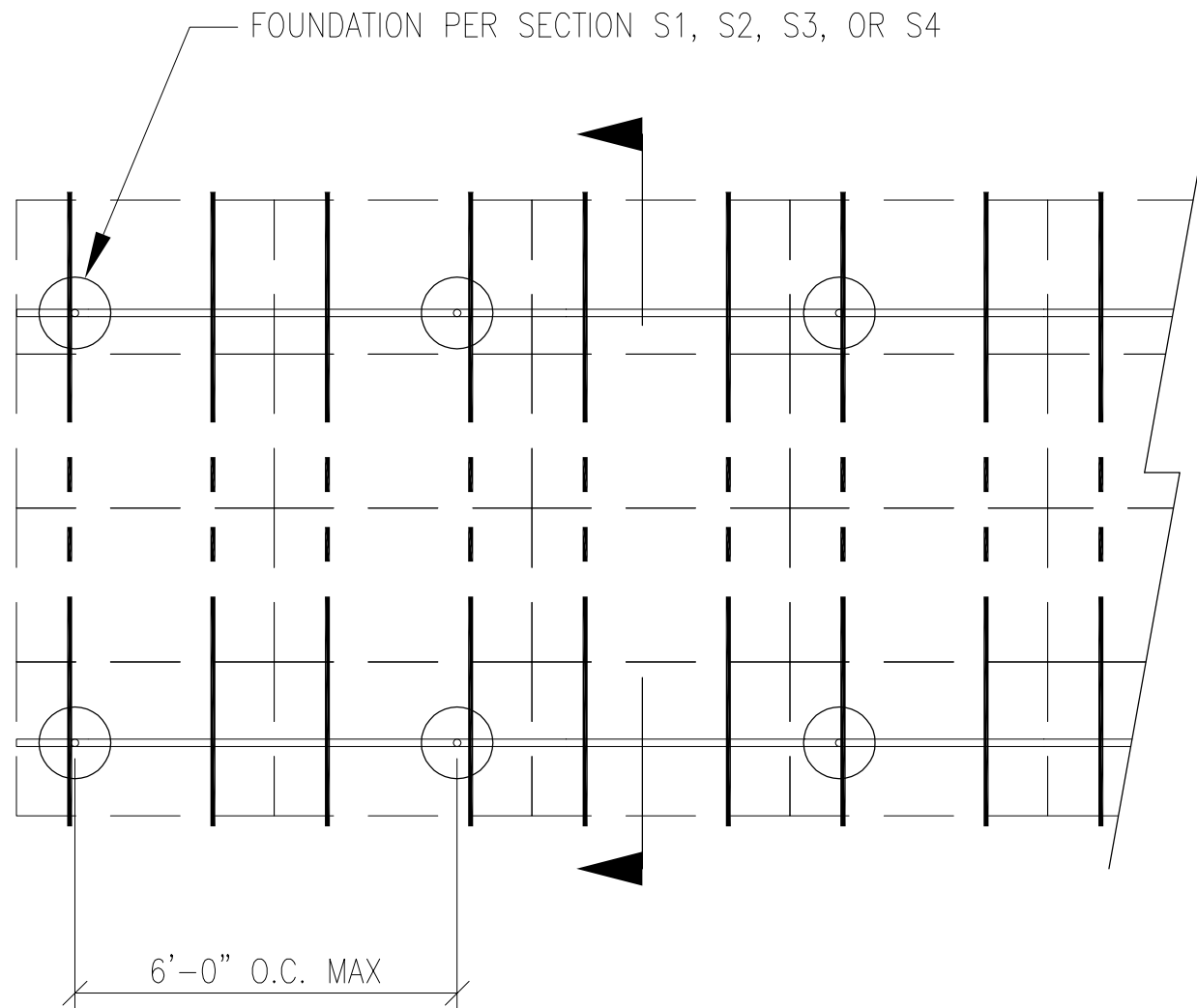

**PV ARRAY PLAN**

N.T.S.

**P1**

Vector Engineers requires that we review each site specific install and is not liable for installs at site specific locations we have not reviewed.

PROJECT SUNMODO SUNTURF GROUND MOUNTS A1

SUBJECT DRILLED PIER OPTION

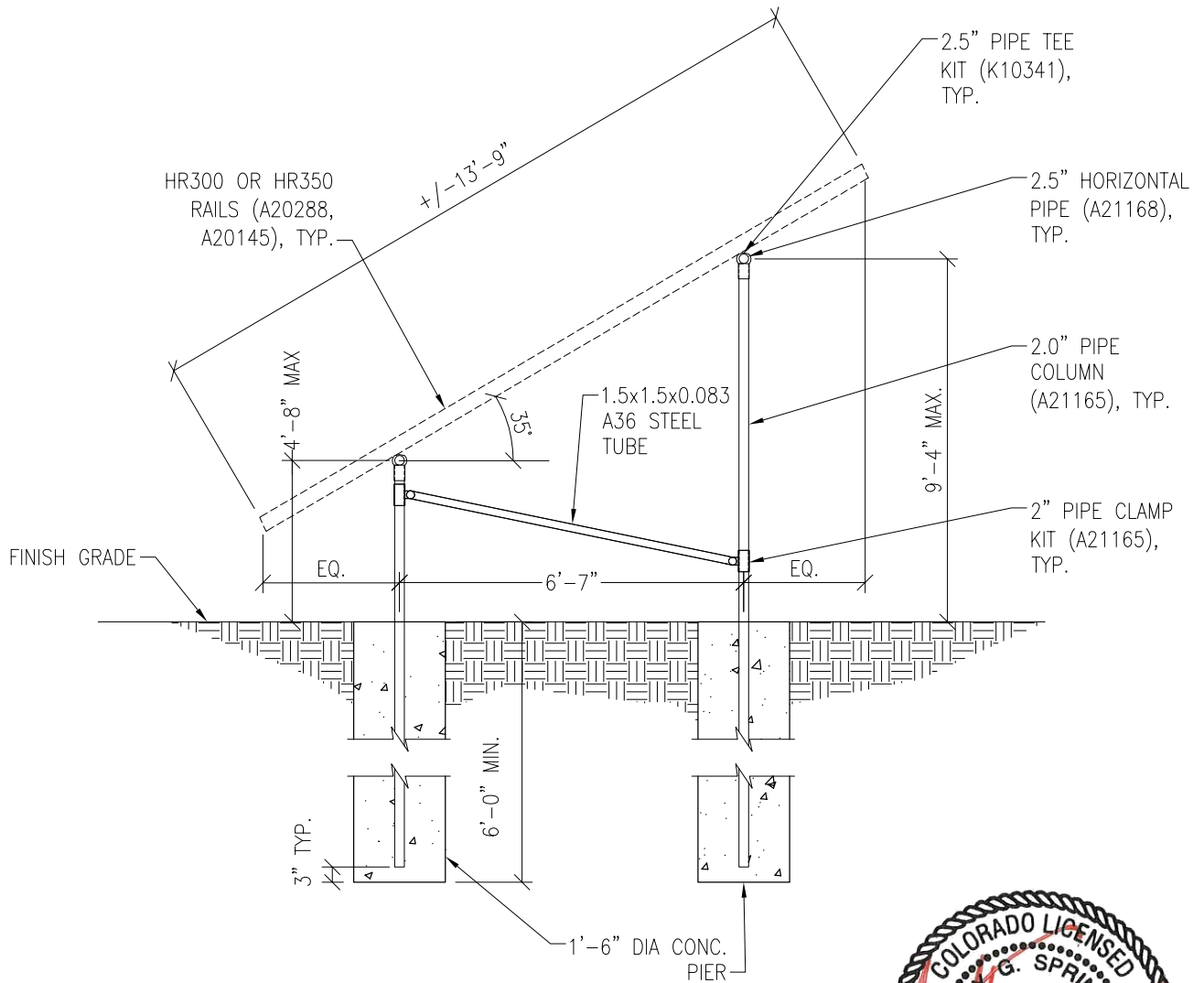

Vector Engineers requires that we review each site specific install and is not liable for installs at site specific locations we have not reviewed.

**PV ARRAY SECTION**

N.T.S.

**S1**

PROJECT SUNMODO SUNTURF GROUND MOUNTS A1

SUBJECT HELICAL PIER OPTION

**NOTES:**

1. For ground mount components see Section S1.
2. A minimum of (1) helical pier must be load-tested as follows:
  - 2.1. Safety factor for uplift = 1.5,
  - 2.2. Safety factor for lateral loads = 2.0
  - 2.3. Upward deflection limit = 1/2"
  - 2.4. Lateral deflection limit = 1"
  - 2.5. The load tests must be performed by an approved contractor.

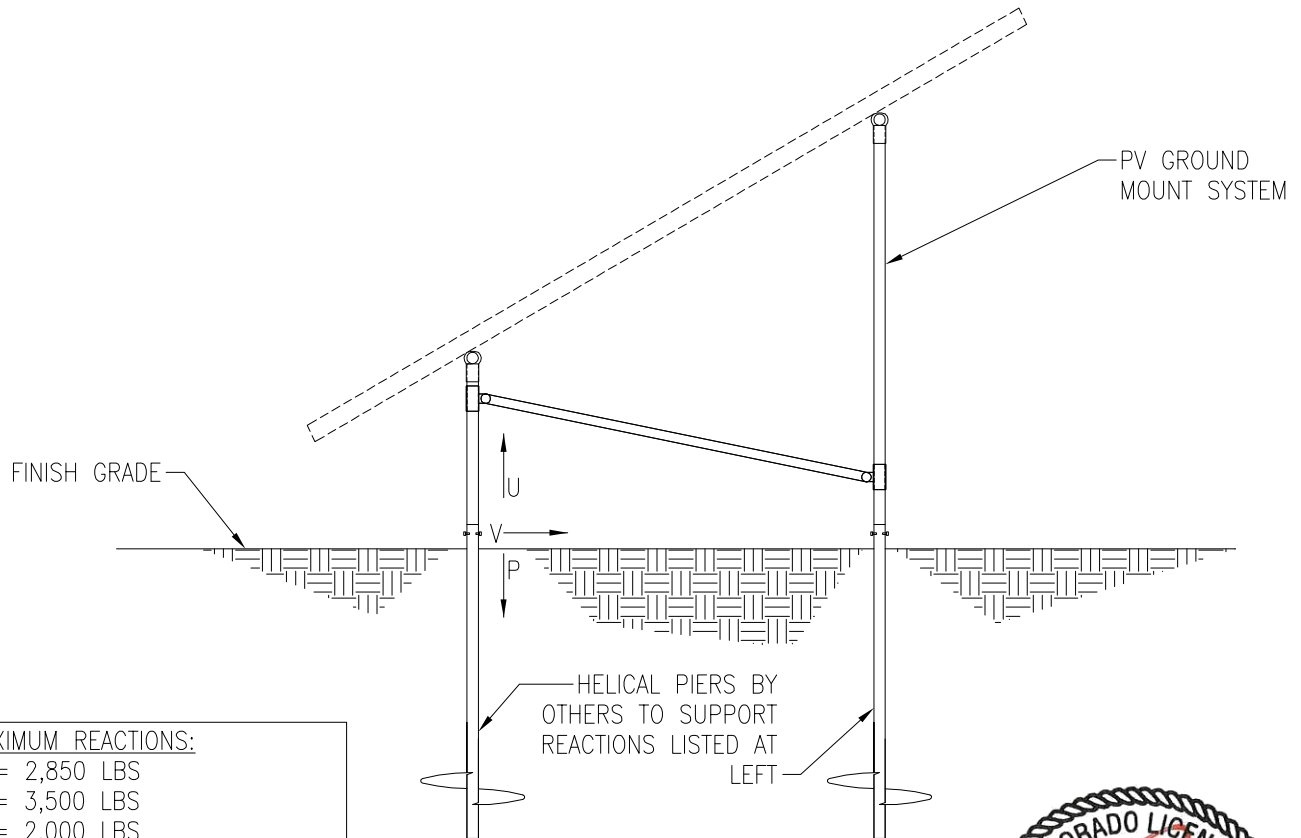

**MAXIMUM REACTIONS:**  
 U = 2,850 LBS  
 P = 3,500 LBS  
 V = 2,000 LBS



**PV ARRAY SECTION**

N.T.S.

**S2**

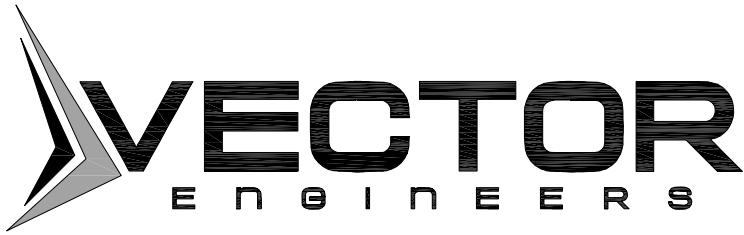

JOB NO. U2716-091-191

PROJECT SUNMODO SUNTURF GROUND MOUNTS A1

SUBJECT GROUND SCREW OPTION

NOTES:

- 1. For ground mount components see Section S1.
- 2. A minimum of (1) ground screw must be load-tested as follows:
  - 2.1. Safety factor for uplift = 1.5,
  - 2.2. Safety factor for lateral loads = 2.0
  - 2.3. Upward deflection limit = 1/2"
  - 2.4. Lateral deflection limit = 1"
  - 2.5. The load tests must be performed by an approved contractor.

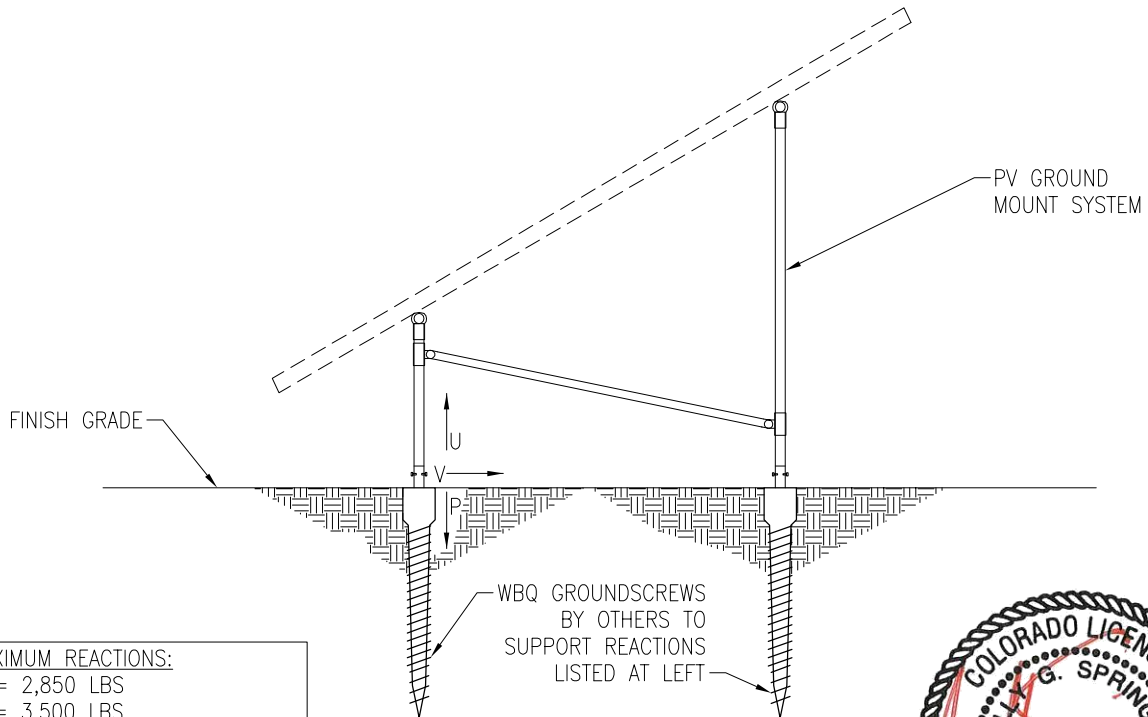

MAXIMUM REACTIONS:  
 U = 2,850 LBS  
 P = 3,500 LBS  
 V = 2,000 LBS



PV ARRAY SECTION

N.T.S.

S3



JOB NO. U2716-091-191

PROJECT SUNMODO SUNTURF GROUND MOUNTS A1

SUBJECT BALLASTED BLOCK OPTION

NOTES:

1. For ground mount components see Section S1.

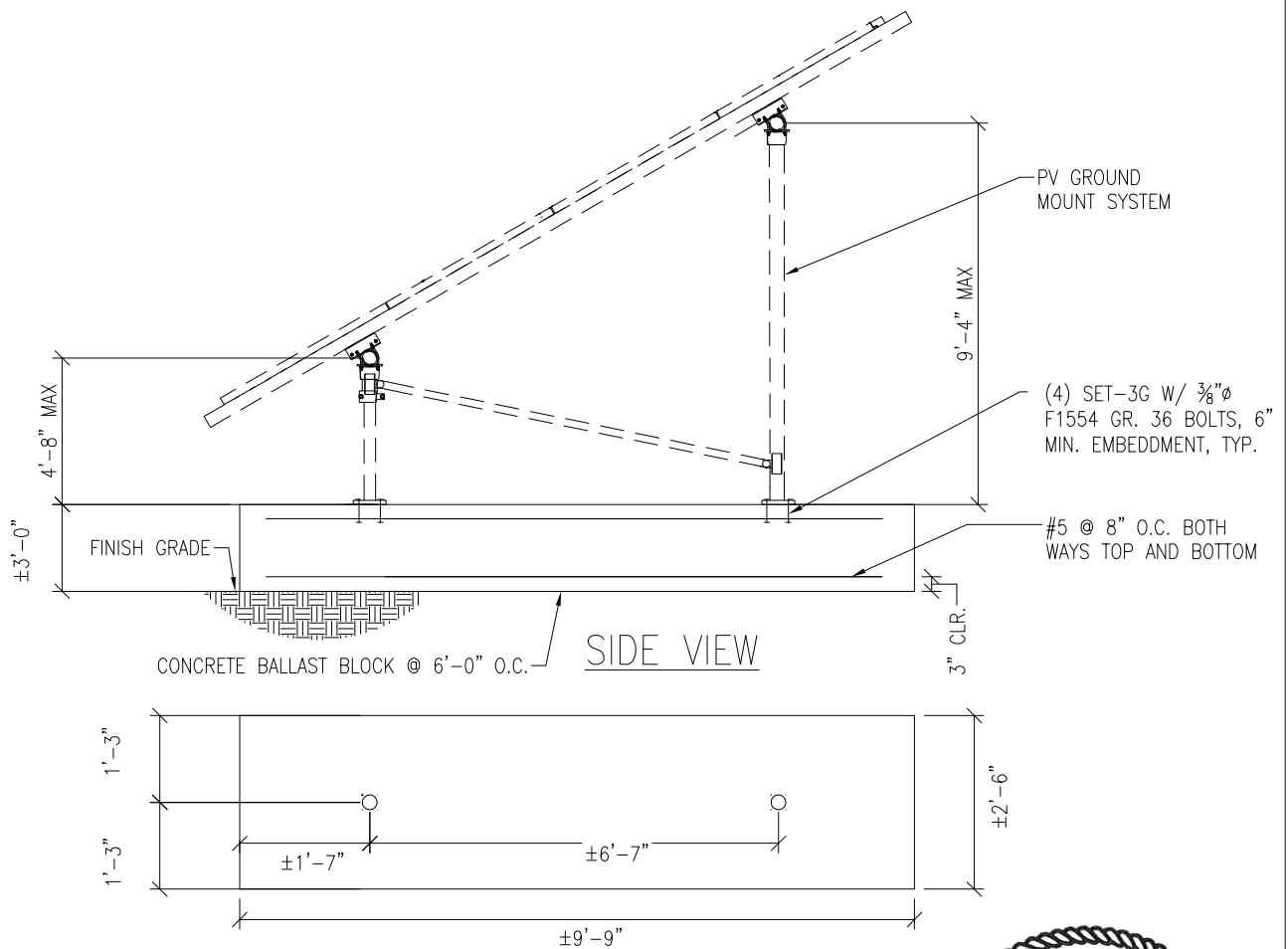

Vector Engineers requires that we review each site specific install and is not liable for installs at site specific locations we have not reviewed.

651 W GALENA PARK BLVD. #101  
DRAPER, UTAH 84020

WWW.VECTORSE.COM

PV ARRAY SECTION

N.T.S.

(801) 990-1775

(801) 990-1776 FAX



S4

PROJECT: A1 – Sunmodo Sunturf GM

SUBJECT: Dead Load

**Design Weight:**

Individual Panel Weight [lb]:	50.7
Panel Transverse Length (T5) [in]:	41.2
Panel Transverse Length (T5) [ft]:	3.4
Panel Longitudinal Length (L2) [in]:	81.4
Panel Longitudinal Length (L2) [ft]:	6.8
Individual Panel Area [ft <sup>2</sup> ]:	23.3
Individual Panel Weight [psf]:	2.2
# of Panels in Transverse Direction:	4
Approximate Transverse Length (T4) [ft]:	13.7
# of Panels in Longitudinal Direction:	12
Approximate Longitudinal Length (L1) [ft]:	81.4
Transverse Column Spacing (T1) [ft]:	6.58
Longitudinal Column Spacing (L3) [ft]:	6.0
# of Columns in Longitudinal Direction:	14
# of Columns in Transverse Direction:	2
Total Number of Columns:	28
Panel Slope from Horizontal (a) [°]:	35.0
Short Column Height (H1) [ft]:	4.67
Approximate Tall Column Height (H2) [ft]:	9.3
Transverse Brace between Columns :	Yes
Approximate Brace Length (B1) [ft]:	9.0
Weight of Columns [plf]:	3.7
Weight of Cross Pipe [plf]:	3.7
Weight of Brace [plf]:	3.7
Tributary Transverse Length per Column [ft]:	6.9
Tributary Longitudinal Length per Column [ft]:	6.0
Tributary Area per Column [ft <sup>2</sup> ]:	41.2
Rail Weight [plf]:	1.0
Transverse Rail Weight per Column [lb]:	13.7
Longitudinal Rail Weight per Column [lb]:	21.9
Tall Column Weight [lb]:	33.9
Panel Weight per Column [lb]:	89.7
Rail Weight per Column [lb]:	13.7
Cross Pipe Weight per Column [lb]:	21.9
Brace Weight per Column [lb]:	16.4
<b>Total Weight per Column (1.0 D) [lb]:</b>	<b>175.7</b>

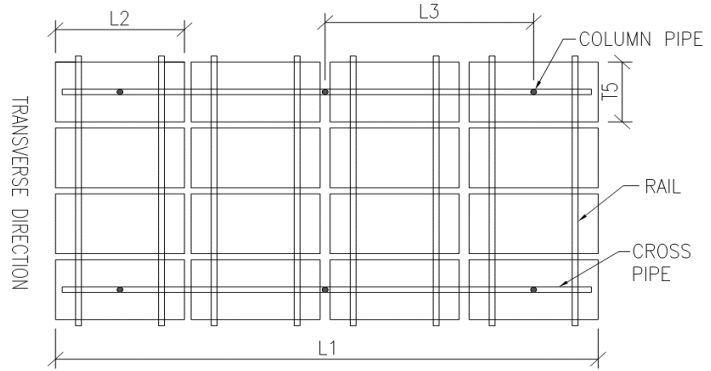

ILLUSTRATION ONLY

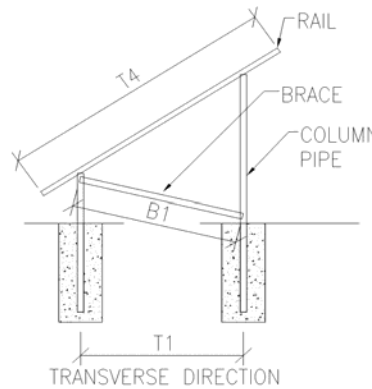

ILLUSTRATION ONLY

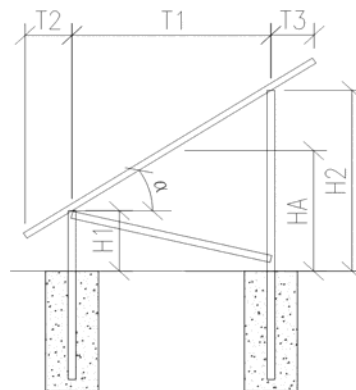

ILLUSTRATION ONLY

**Assumptions:**  
• T2 = T3



JOB NO.: U2716-091-191

DESIGNED: STB

DATE: 07/23/19

PROJECT: A1 – Sunmodo Sunturf GM

SUBJECT: Snow Load

**SNOW LOAD (S):**

ASCE 7 Standard:	10	
Panel Slope from Horizontal [°]:	35.0	
Snow Ground Load, $p_g$ [psf]:	60.0	(Section 7.2)
Terrain Category:	C	(Table 7-2)
Exposure of Roof:	Fully Exposed	(Table 7-2)
Exposure Factor, $C_e$ :	0.9	(Table 7-2)
Thermal Factor, $C_t$ :	1.2	(Table 7-3)
Risk Category:	I	(Table 1.5-1)
Importance Factor, $I_s$ :	0.8	(Table 1.5-2)
Flat Roof Snow Load, $p_f$ [psf]:	36	(Equation 7.3-1)
Minimum Roof Snow Load, $p_m$ [psf]:	0	(Section 7.3.4)
Unobstructed Slippery Surface?	Yes	(Section 7.4)
Slope Factor Figure:	Figure 7-2c	(Section 7.4)
Roof Slope Factor, $C_s$ :	0.636	(Figure 7-2)
Sloped Roof Snow Load, $p_s$ [psf]:	23	(Equation 7.4-1)
Design Snow Load, S [psf]:	23	
Tributary Transverse Length [ft]:	5.6	
Tributary Longitudinal Length [ft]:	6	
Tributary Area per Column [ft <sup>2</sup> ]:	33.7	
<b>Snow Load per Column (1.0 S) [lb]:</b>	<b>779.3</b>	





PROJECT: A1 – Sunmodo Sunturf GM

SUBJECT: Wind Pressure

**Design Wind Load:**

ASCE 7 Standard:	10	
Basic Wind Speed, V [mph]:	135	
Risk Category:	I	
Exposure Category	C	(Section 26.7.3)
Velocity Pressure Exposure Coefficient, $K_h$ :	0.85	(Table 27.3-1)
Topographic Factor, $K_{ht}$ :	1.0	(Section 26.8.2)
Wind Directionality Factor, $K_d$ :	0.85	(Table 26.6-1)
Internal Pressure Coefficient, $GC_{pi}$ :	0.00	(Table 26.11-1)
Velocity Pressure, $q_h$ [psf]:	33.7	(Equation 27.3-1)
Gust Effect Factor, G:	0.85	(Section 26.9.1)
Panel Slope [degrees]:	35.0	

Net Pressure Coefficients ( $C_N$ ) per: (Figure 27.4-4)

Clear Wind Flow	$C_{NW}$	$C_{NL}$
Case 1 ( $\gamma = 0^\circ$ , Load Case A)	-1.80	-1.80
Case 2 ( $\gamma = 0^\circ$ , Load Case B)	-2.43	-0.57
Case 3 ( $\gamma = 180^\circ$ , Load Case A)	2.10	2.17
Case 4 ( $\gamma = 180^\circ$ , Load Case B)	2.67	1.07

Design Wind Pressures (p) [psf] per: (Equation 27.4-3)

Clear Wind Flow	$q_h GC_{NW}$	$q_h GC_{NL}$
Case 1 ( $\gamma = 0^\circ$ , Load Case A)	-51.6	-51.6
Case 2 ( $\gamma = 0^\circ$ , Load Case B)	-69.7	-16.2
Case 3 ( $\gamma = 180^\circ$ , Load Case A)	60.2	62.1
Case 4 ( $\gamma = 180^\circ$ , Load Case B)	76.4	30.6

Wind Pressure on Each Side of Panels [psf]

Clear Wind Flow	Short Col. Pressure	Long Col. Pressure
Case 1 ( $\gamma = 0^\circ$ , Load Case A)	-51.6	-51.6
Case 2 ( $\gamma = 0^\circ$ , Load Case B)	-16.2	-69.7
Case 3 ( $\gamma = 180^\circ$ , Load Case A)	60.2	62.1
Case 4 ( $\gamma = 180^\circ$ , Load Case B)	76.4	30.6



JOB NO.: U2716-091-191

PROJECT: A1 – Sunmodo Sunturf GM

SUBJECT: Open Building Wind Loads

### Design Wind Load Per ASCE 7-10

$$p = q_h G C_n$$

Velocity Pressure Exposure Coefficient, $K_{zt}$ :	0.85	(Table 27.3-1)
Topographic Factor, $K_{ht}$ :	1.0	(Section 26.8.2)
Wind Directionality Factor, $K_d$ :	0.85	(Table 26.6-1)
Ultimate Wind Speed, $V$ [mph]:	135	

Velocity Pressure, $q_h$ [psf]:	33.7	(Equation 27.3-1)
Gust Effect Factor, $G$ :	0.85	(Section 26.9.1)

$\gamma = 90^\circ$  or  $270^\circ$

Force Coefficient,  $C_N$ :

Horizontal Distance from Winward Edge	Roof angle		
	Load Case	Obstructed Wind Flow	
		CN	
$\leq h$	35	A	-0.8
		B	0.8
$> h, \leq 2h$	35	A	-0.6
		B	0.5
$> 2h$	35	A	-0.3
		B	0.3

Design Wind Pressure,  $p$  [psf]:

Horizontal Distance from Winward Edge	Roof angle		
	Load Case	Obstructed Wind Flow	
$\leq h$	35	A	-22.9
		B	22.9
$> h, \leq 2h$	35	A	-17.2
		B	14.3
$> 2h$	35	A	-8.6
		B	8.6



JOB NO.: U2716-091-191

DESIGNED: STB

---

# Foundation Option 1: Drilled Concrete Pier



JOB NO.: U2716-091-191  
DATE: 07/23/19

DESIGNED: STB

PROJECT: A1 – Sunmodo Sunturf GM

**Drilled Pier Design**

**Design Loads:**

Max. Shear, V [k]:	2.0	Max. Down, P <sub>d</sub> [k]:	3.5
Max. Moment, M [k-ft]:	0.0	Max. Uplift, P <sub>u</sub> [k]:	2.9

**Pier Properties:**

Pier Diameter, b [ft]:	1.5	Volume of Concrete [ft <sup>3</sup> ]:	11
Min. Pier Diameter, b <sub>min</sub> (opt'l) [ft]:		Volume of Concrete [yd <sup>3</sup> ]:	0.4
Top of Pier Elevation [ft]:	0.00	Weight of Concrete [k]:	1.6
Pier Depth, d [ft]:	6.0		
Min. Pier Depth, d <sub>min</sub> (opt'l) [ft]:			
Max. Pier Depth, d <sub>max</sub> (opt'l) [ft]:			

**Soil Properties:**

Allow. Bearing Pressure [psf]:	1,500	<u>Optional Parameters for Uplift:</u>	
1/3 increase for short term loads?	No	Skin Friction [psf]:	250 (IBC 1810.3.3.1.4)
Lateral Bearing, S [pcf]:	150	Top Length to Ignore [ft]:	0.0
Max. Lateral Bearing (opt'l) [psf]:		1/3 increase for short term loads?	No
Top Depth to Ignore [ft]:	0.0	Combine w/ Bearing:	No
1/3 increase for short term loads?	No		
1/2" deflection at t/o pier allowed:	Yes		

**Check Bearing:**

Bearing Capacity [k]: 7.1      **Bearing capacity OK.**

**Check Uplift:**

Uplift Capacity [k]: 8.5      **Uplift capacity OK.**

**Check Lateral Bearing:**

Applied Lateral Force, P [lb]:	2,000	
Point of Application, h [ft]:	0.0	
S <sub>1_max</sub> [psf]:		
S <sub>1</sub> [psf]:	600	
A = 2.34*P/(S <sub>1</sub> b):	5.20	
Required Pier Depth, d <sub>reqd</sub> [ft]:	5.2	<b>Lateral bearing capacity OK.</b>

# Foundation Option 2: Helical Pier

The ground screws and helical piers must be tested to 1.5 times uplift and 2.0 times lateral reactions found in the table below.

Load (ASD)	Value (lbs)	Factor of Safety	Test Value (lbs)
UPLIFT	2850	1.5	4275
LATERAL	2000	2	4000

# Foundation Option 3: Ground Screw

The ground screws and helical piers must be tested to 1.5 times uplift and 2.0 times lateral reactions found in the table below.

Load (ASD)	Value (lbs)	Factor of Safety	Test Value (lbs)
UPLIFT	2850	1.5	4275
LATERAL	2000	2	4000



JOB NO.: U2716-091-191

DESIGNED: STB

---

# Foundation Option 4: Ballasted Block

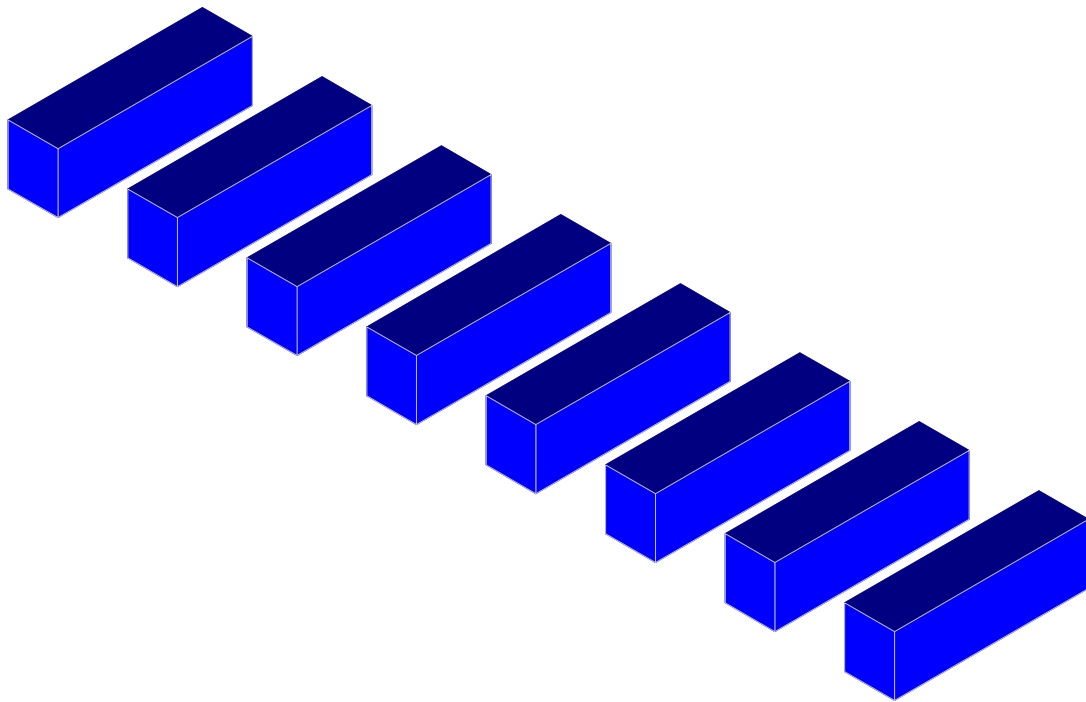

Results for LC 1, 1.0 D

Vector Structural Engineeri..	Ground Mount	SK - 13
STB		June 7, 2019 at 10:55 AM
U2716.091.181		New England A1 v4.r3d



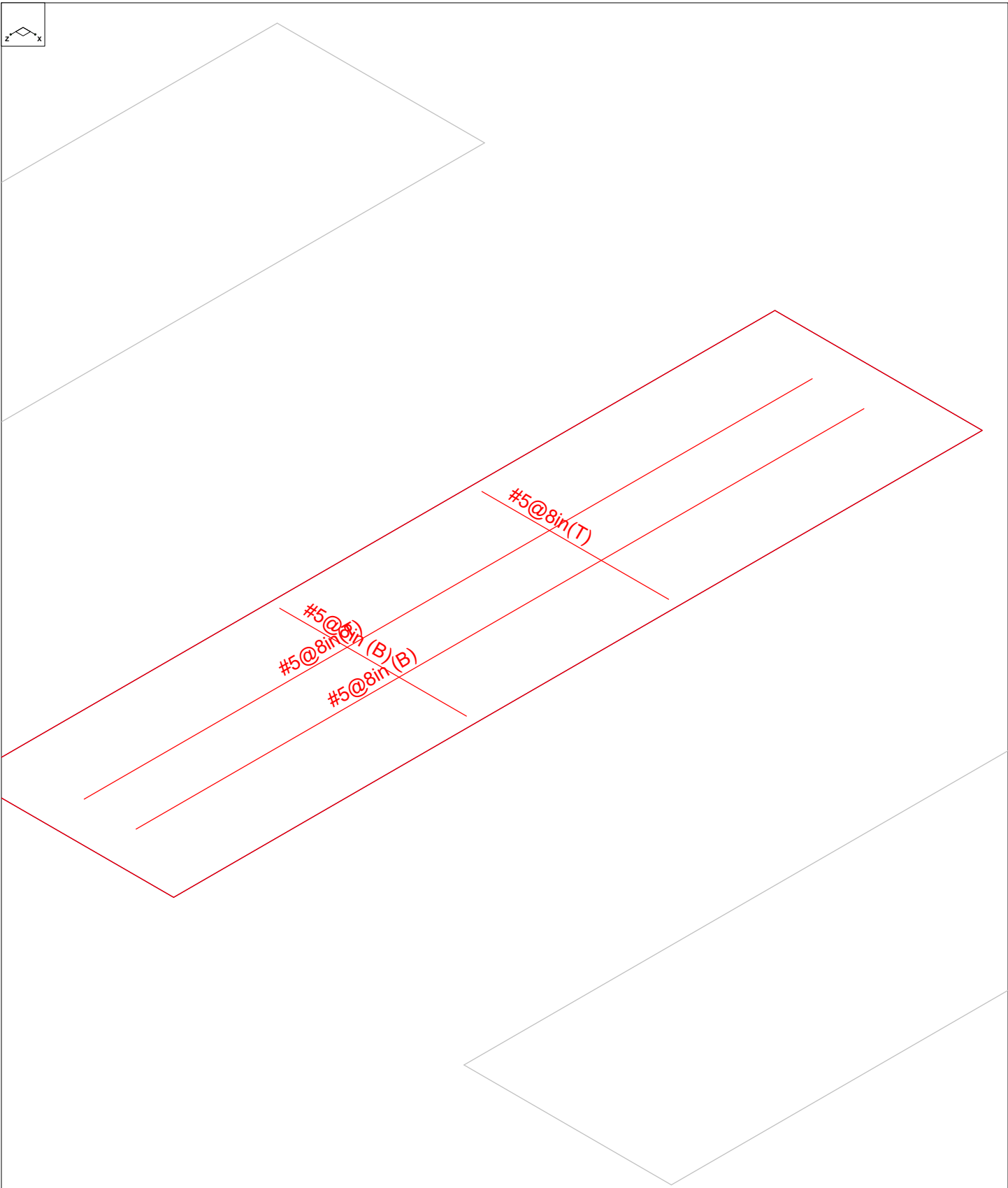

Results for LC 1, 1.0 D

Vector Structural Engineeri..	Ground Mount	SK - 14
STB		June 7, 2019 at 10:55 AM
U2716.091.181		New England A1 v4.r3d



**(Global) Model Settings**

Display Sections for Member Calcs	5
Max Internal Sections for Member Calcs	100
Mesh Size (in)	12
Max Iterations	10
Merge Tolerance (in)	.12
Solver	Sparse Accelerated
Coefficient of Friction	.3
No. of Shear Regions	4
Shear Region Spacing Increment (in)	4
Min 1 Bar Dia Spacing for Beams?	No
Optimize footings for OTM / Sliding?	Yes
Parame Beta Factor	.65
Pile Safety Factor	3
Concrete Stress Block	Rectangular
Concrete Rebar Set	ASTM A615
Concrete Code	ACI 318-14
HR Steel Pile Code	AISC 14th(360-10): ASD
Wood Pile Code	AWC NDS-15: ASD

**Concrete Properties**

	Label	E [ksi]	G [ksi]	Nu	Therm (\...	Density[lb/ft^3]	fc[psi]	Lambda	Flex Stee...	Shear St...
1	Conc3000NW	3156	1372	.15	.6	145	3000	1	60000	60000
2	Conc3500NW	3409	1482	.15	.6	145	3500	1	60000	60000
3	Conc4000NW	3644	1584	.15	.6	145	4000	1	60000	60000
4	Conc3000LW	2085	907	.15	.6	109.999	3000	.75	60000	60000
5	Conc3500LW	2252	979	.15	.6	109.999	3500	.75	60000	60000
6	Conc4000LW	2408	1047	.15	.6	109.999	4000	.75	60000	60000
7	Conc2500NW	3156	1372	.15	.6	145	2500	1	60000	60000

**General Design Parameters**

	Label	Max Bending Chk	Max Shear Chk	Top Cover[in]	Bottom Cover[in]
1	Typical	1	1	3	3

**Slab Rebar Parameters**

	Label	Top Bar	Bottom Bar	Max Top Bar Sp...	Min Top Bar Sp...	Max Bot Bar Sp...	Min Bot Bar Sp...	Spacing Incr...	Rebar Options
1	Typical	#5	#5	8	8	8	8	1	Optimize

**Soil Definitions**

	Label	Subgrade Modulus[lb/ft^3]	Allowable Bearing[psf]	Depth Properties	Default?
1	Default	1e+5	1500	None	Yes

**Point Loads and Moments (Cat 1 : DL)**

	Label	Direction	Magnitude[lb,lb-ft]
1	R3D_N1_1	X	-7.482
2	R3D_N1_1	Y	201.302
3	R3D_N2_1	X	1.457
4	R3D_N2_1	Y	176.247
5	R3D_N132_1	Y	183.764
6	R3D_N133_1	Y	180.055
7	R3D_N109_1	Y	167.515
8	R3D_N110A_1	Y	177.386
9	R3D_N121_1	Y	186.274





**Point Loads and Moments (Cat 16 : OL1) (Continued)**

	Label	Direction	Magnitude[lb.-ft]
10	R3D_N133_1	Z	-121.28
11	R3D_N109_1	X	-3.596
12	R3D_N109_1	Y	-3988.86
13	R3D_N109_1	Z	2546.271
14	R3D_N110A_1	X	10.666
15	R3D_N110A_1	Y	787.574
16	R3D_N110A_1	Z	-121.057
17	R3D_N121_1	X	-6.579
18	R3D_N121_1	Y	-4329.864
19	R3D_N121_1	Z	2572.661
20	R3D_N122_1	X	-3.243
21	R3D_N122_1	Y	789.006
22	R3D_N122_1	Z	-122.023
23	R3D_N133B_1	Y	-4265.729
24	R3D_N133B_1	Z	2567.411
25	R3D_N134B_1	X	-6.452
26	R3D_N134B_1	Y	783.438
27	R3D_N134B_1	Z	-121.931
28	R3D_N151_1	X	-1.547
29	R3D_N151_1	Y	-4218.701
30	R3D_N151_1	Z	2525.296
31	R3D_N152_1	X	7.875
32	R3D_N152_1	Y	754.012
33	R3D_N152_1	Z	-120.453
34	R3D_N157A_2	X	-1.01
35	R3D_N157A_2	Y	-4496.12
36	R3D_N157A_2	Z	2802.265
37	R3D_N158A_2	X	28.575
38	R3D_N158A_2	Y	890.24
39	R3D_N158A_2	Z	-118.544
40	R3D_N157	X	-106.938
41	R3D_N157	Y	-3032.997
42	R3D_N157	Z	1720.718
43	R3D_N158	X	-29.289
44	R3D_N158	Y	520.402
45	R3D_N158	Z	-96.542

**Point Loads and Moments (Cat 17 : OL2)**

	Label	Direction	Magnitude[lb.-ft]
1	R3D_N1_1	X	151.552
2	R3D_N1_1	Y	-4894.435
3	R3D_N1_1	Z	2116.509
4	R3D_N2_1	X	-2.902
5	R3D_N2_1	Y	1729.931
6	R3D_N2_1	Z	-100.537
7	R3D_N132_1	X	1.21
8	R3D_N132_1	Y	-4735.226
9	R3D_N132_1	Z	2153.94
10	R3D_N133_1	X	-9.292
11	R3D_N133_1	Y	1785.987
12	R3D_N133_1	Z	-102.077
13	R3D_N109_1	X	-4.32
14	R3D_N109_1	Y	-4392.23
15	R3D_N109_1	Z	2138.93
16	R3D_N110A_1	X	18.384
17	R3D_N110A_1	Y	1821.131











### Slabs

	Label	Thickness [in]	Material	Local Axis Angle [deg]	Analysis Offset [in]
1	S1	36	Conc2500NW	0	0
2	S2	36	Conc2500NW	0	0
3	S3	36	Conc2500NW	0	0
4	S4	36	Conc2500NW	0	0
5	S5	36	Conc2500NW	0	0
6	S6	36	Conc2500NW	0	0
7	S7	36	Conc2500NW	0	0
8	S8	36	Conc2500NW	0	0

### Load Combinations

	Label	Solve	Service A...	SF	Cat..Fa...	Cat..Fa...	Cat..Fa...	Cat..Fa...	Cat..Fa...	Cat..Fa...	Cat..Fa...	Cat..Fa...	Cat..Fa...	C...	F...	C...	F...
1	1.0 D	Yes	Yes	1.5	DL	1											
2	1.0 D + 1....	Yes	Yes	1.5	DL	1	RLL	1									
3	1.0 D + 0....	Yes	Yes	1.5	DL	1	RLL		OL1	.6							
4	1.0 D + 0....	Yes	Yes	1.5	DL	1	RLL		OL2	.6							
5	1.0 D + 0....	Yes	Yes	1.5	DL	1	RLL		OL3	.6							
6	1.0 D + 0....	Yes	Yes	1.5	DL	1	RLL		OL4	.6							
7	1.0 D + 0....	Yes	Yes	1.5	DL	1	RLL		OL5	.6							
8	1.0 D + 0....	Yes	Yes	1.5	DL	1	RLL		OL6	.6							
9	1.0 D + 0....	Yes	Yes	1.5	DL	1	RLL	.75	OL1	.45							
10	1.0 D + 0....	Yes	Yes	1.5	DL	1	RLL	.75	OL2	.45							
11	1.0 D + 0....	Yes	Yes	1.5	DL	1	RLL	.75	OL3	.45							
12	1.0 D + 0....	Yes	Yes	1.5	DL	1	RLL	.75	OL4	.45							
13	1.0 D + 0....	Yes	Yes	1.5	DL	1	RLL	.75	OL5	.45							
14	1.0 D + 0....	Yes	Yes	1.5	DL	1	RLL	.75	OL6	.45							
15	0.6 D + 0....	Yes	Yes		DL	.6	RLL		OL1	.6							
16	0.6 D + 0....	Yes	Yes		DL	.6	RLL		OL2	.6							
17	0.6 D + 0....	Yes	Yes		DL	.6	RLL		OL3	.6							
18	0.6 D + 0....	Yes	Yes		DL	.6	RLL		OL4	.6							
19	0.6 D + 0....	Yes	Yes		DL	.6	RLL		OL5	.6							
20	0.6 D + 0....	Yes	Yes		DL	.6	RLL		OL6	.6							
21																	
22	1.4D	Yes			DL	1.4											
23	1.2D+1.6SL	Yes			DL	1.2	RLL	1.6									
24	1.2D+1.6S...	Yes			DL	1.2	RLL	1.6	OL1	.5							
25	1.2D+1.6S...	Yes			DL	1.2	RLL	1.6	OL2	.5							
26	1.2D+1.6S...	Yes			DL	1.2	RLL	1.6	OL3	.5							
27	1.2D+1.6S...	Yes			DL	1.2	RLL	1.6	OL4	.5							
28	1.2D+1.6S...	Yes			DL	1.2	RLL	1.6	OL5	.5							
29	1.2D+1.6S...	Yes			DL	1.2	RLL	1.6	OL6	.5							
30	1.2D+1.0...	Yes			DL	1.2			OL1	1							
31	1.2D-1.0Wx	Yes			DL	1.2			OL2	1							
32	1.2D+1.0...	Yes			DL	1.2			OL3	1							
33	1.2D-1.0Wz	Yes			DL	1.2			OL4	1							
34	1.2D+1.0...	Yes			DL	1.2			OL5	1							
35	1.2D-1.0...	Yes			DL	1.2			OL6	1							
36	.9D+1.0Wx	Yes			DL	.9			OL1	1							
37	.9D-1.0Wx	Yes			DL	.9			OL2	1							
38	.9D+1.0Wz	Yes			DL	.9			OL3	1							
39	.9D-1.0Wz	Yes			DL	.9			OL4	1							
40	.9D+1.0W...	Yes			DL	.9			OL5	1							
41	.9D-1.0W90	Yes			DL	.9			OL6	1							



Company : Vector Structural Engineering  
 Designer : STB  
 Job Number : U2716.091.181  
 Model Name : Ground Mount

July 23, 2019  
 11:04 AM  
 Checked By: JSP

### Design Strips

	Label	Rebar Angle from Pl...	No. of Design Cuts	Design Rule
1	DS1	0	50	Typical
2	DS2	90	50	Typical

### Load Categories

	Category	Point Loads	Line Loads	Area Loads
1	DL	21		
2	RLL	29		
3	OL1	45		
4	OL2	46		
5	OL3	47		
6	OL4	44		
7	OL5	45		
8	OL6	43		

### Strip Reinforcing

	Label	UC Top	LC	Top Bars	Governing ...	UC Bot	LC	Bot B...	Gover...	UC Shear	LC	Governing ...
1	DS1	.012	26	#5@8in	DS1-X26	.019	37	#5@8in	DS1-...	.03	37	DS1-X15
2	DS2	.001	36	#5@8in	DS2-X26	.002	26	#5@8in	DS2-...	.004	26	DS2-X25

### Slab Overturning Safety Factors (By Combination)

	LC	Slab	Angle[deg]	Mo-xx[lb-ft]	Ms-xx[lb-ft]	Mo-zz[lb-ft]	Ms-zz[lb-ft]	Ms-xx/Mo-xx	Ms-zz/Mo-zz
1	1	S1	0	0	53448.486	0	13743.938	9.999+	9.999+
2	1	S2	0	0	53404.294	0	13685.056	9.999+	9.999+
3	1	S3	0	0	53461.281	0	13712.68	9.999+	9.999+
4	1	S4	0	0	53448.366	0	13707.42	9.999+	9.999+
5	1	S5	0	0	53451.822	0	13708.703	9.999+	9.999+
6	1	S6	0	0	53427.693	0	13703.531	9.999+	9.999+
7	1	S7	0	0	53549.842	0	13733.198	9.999+	9.999+
8	1	S8	0	0	52972.385	0	13572.975	9.999+	9.999+
9	2	S1	0	0	61128.428	0	15816.818	9.999+	9.999+
10	2	S2	0	0	60947.868	0	15503.779	9.999+	9.999+
11	2	S3	0	0	61287.659	0	15674.029	9.999+	9.999+
12	2	S4	0	0	61207.033	0	15659.421	9.999+	9.999+
13	2	S5	0	0	61225.451	0	15671.76	9.999+	9.999+
14	2	S6	0	0	61077.851	0	15638.875	9.999+	9.999+
15	2	S7	0	0	61834.556	0	15807.1	9.999+	9.999+
16	2	S8	0	0	58245.968	0	14799.03	9.999+	9.999+
17	3	S1	0	25075.534	53613.442	2918.45	13743.938	2.138	4.709
18	3	S2	0	23162.644	53339.322	2413.691	13685.056	2.303	5.67
19	3	S3	0	24877.974	53497.808	2673.323	13712.68	2.15	5.129
20	3	S4	0	24559.712	53469.692	2623.331	13707.42	2.177	5.225
21	3	S5	0	24524.189	53476.246	2624.942	13708.703	2.181	5.222
22	3	S6	0	24284.081	53460.033	2609.908	13703.531	2.201	5.251
23	3	S7	0	26016.001	53519.076	2754.026	13733.198	2.057	4.987
24	3	S8	0	17290.854	53142.686	2129.656	13635.971	3.073	6.403
25	4	S1	0	25968.085	53613.442	2640.946	13743.938	2.065	5.204
26	4	S2	0	23458.407	53339.322	1953.64	13685.056	2.274	7.005
27	4	S3	0	25656.691	53497.808	2268.207	13712.68	2.085	6.046
28	4	S4	0	25247.542	53469.692	2219.51	13707.42	2.118	6.176
29	4	S5	0	25199.309	53476.246	2226.477	13708.703	2.122	6.157
30	4	S6	0	24987.309	53460.033	2204.251	13703.531	2.139	6.217
31	4	S7	0	26454.384	53519.076	2231.922	13733.198	2.023	6.153
32	4	S8	0	17960.468	53142.686	1915.227	13635.971	2.959	7.12
33	5	S1	0	4732.077	53448.486	0	17210.048	9.999+	9.999+
34	5	S2	0	5423.756	53404.294	0	16543.498	9.846	9.999+



Company : Vector Structural Engineering  
 Designer : STB  
 Job Number : U2716.091.181  
 Model Name : Ground Mount

July 23, 2019  
 11:04 AM  
 Checked By: JSP

**Slab Overturning Safety Factors (By Combination) (Continued)**

	LC	Slab	Angle[deg]	Mo-xx[lb-ft]	Ms-xx[lb-ft]	Mo-zz[lb-ft]	Ms-zz[lb-ft]	Ms-xx/Mo-xx	Ms-zz/Mo-zz
35	5	S3	0	5099.111	53461.281	0	16840.221	9.999+	9.999+
36	5	S4	0	5127.876	53448.366	0	16789.059	9.999+	9.999+
37	5	S5	0	4961.587	53451.822	0	16820.299	9.999+	9.999+
38	5	S6	0	4917.968	53427.693	0	16797.605	9.999+	9.999+
39	5	S7	0	6014.288	53549.842	0	16994.723	8.904	9.999+
40	5	S8	0	3175.557	52972.385	0	15516.446	9.999+	9.999+
41	6	S1	0	380.591	53448.486	0	16588.592	9.999+	9.999+
42	6	S2	0	552.72	53404.294	0	16235.074	9.999+	9.999+
43	6	S3	0	350.784	53461.281	0	16415.284	9.999+	9.999+
44	6	S4	0	378.574	53448.366	0	16396.146	9.999+	9.999+
45	6	S5	0	281.756	53451.822	0	16419.378	9.999+	9.999+
46	6	S6	0	327.176	53427.693	0	16382.268	9.999+	9.999+
47	6	S7	0	719.344	53549.842	0	16643.545	9.999+	9.999+
48	6	S8	0	188.693	52972.385	0	15252.135	9.999+	9.999+
49	7	S1	0	1703.584	53448.486	0	14966.464	9.999+	9.999+
50	7	S2	0	1665.257	53404.294	0	14619.542	9.999+	9.999+
51	7	S3	0	1110.346	53461.281	0	14429.138	9.999+	9.999+
52	7	S4	0	722.071	53448.366	0	14143.045	9.999+	9.999+
53	7	S5	0	653.953	53451.822	0	14148.698	9.999+	9.999+
54	7	S6	0	670.708	53427.693	0	14141.07	9.999+	9.999+
55	7	S7	0	833.496	53549.842	0	14178.689	9.999+	9.999+
56	7	S8	0	423.009	52972.385	0	13844.425	9.999+	9.999+
57	8	S1	0	10763.894	53613.442	1220.507	13743.938	4.981	9.999+
58	8	S2	0	7911.609	53339.322	830.772	13685.056	6.742	9.999+
59	8	S3	0	5763.619	53497.808	622.916	13712.68	9.282	9.999+
60	8	S4	0	4169.268	53469.692	443.456	13707.42	9.999+	9.999+
61	8	S5	0	4069.209	53476.246	438.534	13708.703	9.999+	9.999+
62	8	S6	0	4064.305	53460.033	437.745	13703.531	9.999+	9.999+
63	8	S7	0	4248.827	53519.076	445.629	13733.198	9.999+	9.999+
64	8	S8	0	2963.451	53142.686	379.893	13635.971	9.999+	9.999+
65	9	S1	0	18806.65	59474.773	2188.838	15298.598	3.162	6.989
66	9	S2	0	17371.983	58341.69	1810.268	15049.098	3.358	8.313
67	9	S3	0	18658.481	59157.313	2004.992	15197.892	3.171	7.58
68	9	S4	0	18419.784	59016.331	1967.498	15157.68	3.204	7.704
69	9	S5	0	18393.142	59046.215	1968.707	15159.531	3.21	7.7
70	9	S6	0	18213.06	58977.907	1957.431	15155.039	3.238	7.742
71	9	S7	0	19512.001	59213.813	2065.52	15288.624	3.035	7.402
72	9	S8	0	12968.14	57234.357	1597.242	14779.723	4.413	9.253
73	10	S1	0	19476.064	59474.773	1980.71	15298.598	3.054	7.724
74	10	S2	0	17593.805	58341.69	1465.23	15049.098	3.316	9.999+
75	10	S3	0	19242.518	59157.313	1701.155	15197.892	3.074	8.934
76	10	S4	0	18935.657	59016.331	1664.633	15157.68	3.117	9.106
77	10	S5	0	18899.482	59046.215	1669.858	15159.531	3.124	9.078
78	10	S6	0	18740.482	58977.907	1653.189	15155.039	3.147	9.167
79	10	S7	0	19840.788	59213.813	1673.942	15288.624	2.984	9.133
80	10	S8	0	13470.351	57234.357	1436.421	14779.723	4.249	9.999+
81	11	S1	0	3549.057	59208.442	0	17898.18	9.999+	9.999+
82	11	S2	0	4067.817	59061.974	0	17192.93	9.999+	9.999+
83	11	S3	0	3824.333	59331.065	0	17529.348	9.999+	9.999+
84	11	S4	0	3845.907	59267.366	0	17482.65	9.999+	9.999+
85	11	S5	0	3721.19	59282.044	0	17514.693	9.999+	9.999+
86	11	S6	0	3688.476	59165.311	0	17475.595	9.999+	9.999+
87	11	S7	0	4510.716	59763.378	0	17734.768	9.999+	9.999+
88	11	S8	0	2381.668	56927.572	0	15950.12	9.999+	9.999+
89	12	S1	0	285.443	59208.442	0	17432.088	9.999+	9.999+
90	12	S2	0	414.54	59061.974	0	16961.612	9.999+	9.999+
91	12	S3	0	263.088	59331.065	0	17210.645	9.999+	9.999+





Company : Vector Structural Engineering  
 Designer : STB  
 Job Number : U2716.091.181  
 Model Name : Ground Mount

July 23, 2019  
 11:04 AM  
 Checked By: JSP

**Slab Overturning Safety Factors (By Combination) (Continued)**

	LC	Slab	Angle[deg]	Mo-xx[lb-ft]	Ms-xx[lb-ft]	Mo-zz[lb-ft]	Ms-zz[lb-ft]	Ms-xx/Mo-xx	Ms-zz/Mo-zz
149	19	S5	0	653.953	32071.093	0	8665.217	9.999+	9.999+
150	19	S6	0	670.708	32056.616	0	8659.657	9.999+	9.999+
151	19	S7	0	833.496	32129.905	0	8685.41	9.999+	9.999+
152	19	S8	0	423.009	31783.431	0	8415.235	9.999+	9.999+
153	20	S1	0	10763.894	32168.065	1220.507	8246.363	2.989	6.757
154	20	S2	0	7911.609	32003.593	830.772	8211.033	4.045	9.884
155	20	S3	0	5763.619	32098.685	622.916	8227.608	5.569	9.999+
156	20	S4	0	4169.268	32081.815	443.456	8224.452	7.695	9.999+
157	20	S5	0	4069.209	32085.748	438.534	8225.222	7.885	9.999+
158	20	S6	0	4064.305	32076.02	437.745	8222.119	7.892	9.999+
159	20	S7	0	4248.827	32111.446	445.629	8239.919	7.558	9.999+
160	20	S8	0	2963.451	31885.612	379.893	8181.582	9.999+	9.999+

**Slab Sliding Safety Factors (By Combination)**

	LC	Slab	Angle[deg]	Va-xx[lb]	Vr-xx[lb]	Va-zz[lb]	Vr-zz[lb]	SR-xx	SR-zz
1	1	S1	0	6.025	3294.208	0	3294.208	9.999+	9.999+
2	1	S2	0	0	3284.413	0	3284.413	9.999+	9.999+
3	1	S3	0	0	3291.043	0	3291.043	9.999+	9.999+
4	1	S4	0	0	3289.781	0	3289.781	9.999+	9.999+
5	1	S5	0	0	3290.089	0	3290.089	9.999+	9.999+
6	1	S6	0	0	3288.847	0	3288.847	9.999+	9.999+
7	1	S7	0	2.146	3294.423	0	3294.423	9.999+	9.999+
8	1	S8	0	10.499	3265.074	0	3265.074	9.999+	9.999+
9	2	S1	0	34.804	3770.977	0	3770.977	9.999+	9.999+
10	2	S2	0	1.168	3721.748	0	3721.748	9.999+	9.999+
11	2	S3	0	3.156	3764.039	1.028	3764.039	9.999+	9.999+
12	2	S4	0	3.053	3756.063	0	3756.063	9.999+	9.999+
13	2	S5	0	4.77	3757.788	0	3757.788	9.999+	9.999+
14	2	S6	0	3.777	3750.61	0	3750.61	9.999+	9.999+
15	2	S7	0	14.913	3782.966	0	3782.966	9.999+	9.999+
16	2	S8	0	60.324	3595.2	0	3595.2	9.999+	9.999+
17	3	S1	0	60.406	2641.609	1431.817	2641.609	9.999+	1.845
18	3	S2	0	4.242	2708.182	1455.128	2708.182	9.999+	1.861
19	3	S3	0	5.893	2653.689	1470.383	2653.689	9.999+	1.805
20	3	S4	0	3.871	2662.969	1467.288	2662.969	9.999+	1.815
21	3	S5	0	0	2660.103	1463.312	2660.103	9.999+	1.818
22	3	S6	0	3.797	2665.204	1442.905	2665.204	9.999+	1.847
23	3	S7	0	14.393	2645.364	1610.233	2645.364	9.999+	1.643
24	3	S8	0	71.237	2812.806	974.506	2812.806	9.999+	2.886
25	4	S1	0	83.165	2724.597	1209.583	2724.597	9.999+	2.253
26	4	S2	0	8.439	2821.616	1222.174	2821.616	9.999+	2.309
27	4	S3	0	5.75	2750.814	1241.118	2750.814	9.999+	2.216
28	4	S4	0	7.743	2762.673	1237.482	2762.673	9.999+	2.232
29	4	S5	0	4.849	2759.226	1231.117	2759.226	9.999+	2.241
30	4	S6	0	1.266	2760.738	1216.181	2760.738	9.999+	2.27
31	4	S7	0	5.187	2764.041	1353.361	2764.041	9.999+	2.042
32	4	S8	0	77.319	2868.648	825.018	2868.648	9.999+	3.477
33	5	S1	0	85.953	4068.525	1697.446	4068.525	9.999+	2.397
34	5	S2	0	5.201	3966.694	1724.83	3966.694	9.999+	2.3
35	5	S3	0	7.014	4046.703	1743.13	4046.703	9.999+	2.322
36	5	S4	0	4.748	4032.793	1739.424	4032.793	9.999+	2.318
37	5	S5	0	.041	4036.902	1734.603	4036.902	9.999+	2.327
38	5	S6	0	4.433	4028.234	1710.493	4028.234	9.999+	2.355
39	5	S7	0	21.496	4063.256	1908.714	4063.256	9.999+	2.129
40	5	S8	0	108.066	3801.755	1155.357	3801.755	9.999+	3.291
41	6	S1	0	45.884	3948.226	1469.31	3948.226	9.999+	2.687



Company : Vector Structural Engineering  
 Designer : STB  
 Job Number : U2716.091.181  
 Model Name : Ground Mount

July 23, 2019  
 11:04 AM  
 Checked By: JSP

**Slab Sliding Safety Factors (By Combination) (Continued)**

	LC	Slab	Angle[deg]	Va-xx[lb]	Vr-xx[lb]	Va-zz[lb]	Vr-zz[lb]	SR-xx	SR-zz
42	6	S2	0	.197	3896.276	1499.312	3896.276	9.999+	2.599
43	6	S3	0	5.387	3943.547	1509.781	3943.547	9.999+	2.612
44	6	S4	0	0	3935.075	1507.479	3935.075	9.999+	2.61
45	6	S5	0	4.07	3937.721	1505.971	3937.721	9.999+	2.615
46	6	S6	0	5.559	3927.742	1483.059	3927.742	9.999+	2.648
47	6	S7	0	25.861	3975.831	1658.343	3975.831	9.999+	2.397
48	6	S8	0	78.309	3716.895	998.511	3716.895	9.999+	3.722
49	7	S1	0	25.602	3573.518	625.433	3573.518	9.999+	5.714
50	7	S2	0	.509	3509.056	557.165	3509.056	9.999+	6.298
51	7	S3	0	4.262	3466.062	402.282	3466.062	9.999+	8.616
52	7	S4	0	0	3394.331	247.127	3394.331	9.999+	9.999+
53	7	S5	0	.637	3395.229	242.174	3395.229	9.999+	9.999+
54	7	S6	0	.832	3393.257	240.826	3393.257	9.999+	9.999+
55	7	S7	0	4.746	3399.468	267.993	3399.468	9.999+	9.999+
56	7	S8	0	28.637	3343.281	162.657	3343.281	9.999+	9.999+
57	8	S1	0	13.219	3015.141	624.741	3015.141	9.999+	4.826
58	8	S2	0	2.097	3086.538	494.739	3086.538	9.999+	6.239
59	8	S3	0	1.898	3142.91	340.75	3142.91	9.999+	9.224
60	8	S4	0	0	3183.351	249.306	3183.351	9.999+	9.999+
61	8	S5	0	.685	3185.334	242.552	3185.334	9.999+	9.999+
62	8	S6	0	.8	3184.365	240.749	3184.365	9.999+	9.999+
63	8	S7	0	.451	3189.341	268.001	3189.341	9.999+	9.999+
64	8	S8	0	7.569	3186.909	162.659	3186.909	9.999+	9.999+
65	9	S1	0	22.214	3162.336	1073.863	3162.336	9.999+	2.945
66	9	S2	0	4.057	3180.241	1091.346	3180.241	9.999+	2.914
67	9	S3	0	2.053	3167.774	1103.559	3167.774	9.999+	2.871
68	9	S4	0	5.193	3169.383	1100.466	3169.383	9.999+	2.88
69	9	S5	0	3.577	3168.374	1097.484	3168.374	9.999+	2.887
70	9	S6	0	.015	3167.437	1082.179	3167.437	9.999+	2.927
71	9	S7	0	.683	3174.037	1207.674	3174.037	9.999+	2.628
72	9	S8	0	13.435	3173.468	730.879	3173.468	9.999+	4.342
73	10	S1	0	39.283	3224.577	907.187	3224.577	9.999+	3.554
74	10	S2	0	7.205	3265.316	916.631	3265.316	9.999+	3.562
75	10	S3	0	1.946	3240.618	931.61	3240.618	9.999+	3.479
76	10	S4	0	8.097	3244.162	928.112	3244.162	9.999+	3.495
77	10	S5	0	7.214	3242.716	923.338	3242.716	9.999+	3.512
78	10	S6	0	1.884	3239.088	912.136	3239.088	9.999+	3.551
79	10	S7	0	6.222	3263.044	1015.021	3263.044	9.999+	3.215
80	10	S8	0	17.996	3215.35	618.763	3215.35	9.999+	5.196
81	11	S1	0	87.556	4232.523	1273.084	4232.523	9.999+	3.325
82	11	S2	0	3.025	4124.125	1293.622	4124.125	9.999+	3.188
83	11	S3	0	7.627	4212.535	1306.576	4212.535	9.999+	3.224
84	11	S4	0	1.271	4196.751	1304.568	4196.751	9.999+	3.217
85	11	S5	0	3.546	4200.973	1300.952	4200.973	9.999+	3.229
86	11	S6	0	6.157	4189.709	1282.87	4189.709	9.999+	3.266
87	11	S7	0	26.234	4237.456	1431.536	4237.456	9.999+	2.96
88	11	S8	0	121.043	3915.18	866.518	3915.18	9.999+	4.518
89	12	S1	0	57.504	4142.298	1101.982	4142.298	9.999+	3.759
90	12	S2	0	.728	4071.311	1124.484	4071.311	9.999+	3.621
91	12	S3	0	6.407	4135.168	1131.564	4135.168	9.999+	3.654
92	12	S4	0	2.29	4123.463	1130.609	4123.463	9.999+	3.647
93	12	S5	0	6.63	4126.587	1129.478	4126.587	9.999+	3.654
94	12	S6	0	7.002	4114.34	1112.294	4114.34	9.999+	3.699
95	12	S7	0	29.508	4171.886	1243.757	4171.886	9.999+	3.354
96	12	S8	0	98.725	3851.535	748.883	3851.535	9.999+	5.143
97	13	S1	0	42.292	3861.268	469.075	3861.268	9.999+	8.232
98	13	S2	0	1.257	3780.896	417.873	3780.896	9.999+	9.048



Company : Vector Structural Engineering  
 Designer : STB  
 Job Number : U2716.091.181  
 Model Name : Ground Mount

July 23, 2019  
 11:04 AM  
 Checked By: JSP

**Slab Sliding Safety Factors (By Combination) (Continued)**

	LC	Slab	Angle[deg]	Va-xx[lb]	Vr-xx[lb]	Va-zz[lb]	Vr-zz[lb]	SR-xx	SR-zz
99	13	S3	0	5.563	3777.054	300.94	3777.054	9.999+	9.999+
100	13	S4	0	2.29	3717.905	185.345	3717.905	9.999+	9.999+
101	13	S5	0	4.055	3719.718	181.631	3719.718	9.999+	9.999+
102	13	S6	0	3.457	3713.477	180.619	3713.477	9.999+	9.999+
103	13	S7	0	13.672	3739.615	200.995	3739.615	9.999+	9.999+
104	13	S8	0	61.471	3571.324	121.993	3571.324	9.999+	9.999+
105	14	S1	0	13.177	3442.485	468.556	3442.485	9.999+	7.347
106	14	S2	0	.697	3464.008	371.054	3464.008	9.999+	9.336
107	14	S3	0	.943	3534.69	256.334	3534.69	9.999+	9.999+
108	14	S4	0	2.29	3559.67	186.98	3559.67	9.999+	9.999+
109	14	S5	0	3.064	3562.297	181.914	3562.297	9.999+	9.999+
110	14	S6	0	2.233	3556.808	180.562	3556.808	9.999+	9.999+
111	14	S7	0	9.774	3582.019	201.001	3582.019	9.999+	9.999+
112	14	S8	0	34.316	3454.045	121.994	3454.045	9.999+	9.999+
113	15	S1	0	62.816	1323.926	1431.817	1323.926	9.999+	.925
114	15	S2	0	4.242	1394.416	1455.128	1394.416	9.999+	.958
115	15	S3	0	5.893	1337.271	1470.383	1337.271	9.999+	.909
116	15	S4	0	3.871	1347.056	1467.288	1347.056	9.999+	.918
117	15	S5	0	0	1344.067	1463.312	1344.067	9.999+	.919
118	15	S6	0	3.797	1349.665	1442.905	1349.665	9.999+	.935
119	15	S7	0	15.252	1327.595	1610.233	1327.595	9.999+	.824
120	15	S8	0	75.437	1506.777	974.506	1506.777	9.999+	1.546
121	16	S1	0	85.575	1406.914	1209.583	1406.914	9.999+	1.163
122	16	S2	0	8.439	1507.85	1222.174	1507.85	9.999+	1.234
123	16	S3	0	5.75	1434.396	1241.118	1434.396	9.999+	1.156
124	16	S4	0	7.743	1446.761	1237.482	1446.761	9.999+	1.169
125	16	S5	0	4.849	1443.19	1231.117	1443.19	9.999+	1.172
126	16	S6	0	1.266	1445.199	1216.181	1445.199	9.999+	1.188
127	16	S7	0	6.045	1446.272	1353.361	1446.272	9.999+	1.069
128	16	S8	0	81.519	1562.619	825.018	1562.619	9.999+	1.894
129	17	S1	0	83.544	2750.842	1697.446	2750.842	9.999+	1.621
130	17	S2	0	5.201	2652.929	1724.83	2652.929	9.999+	1.538
131	17	S3	0	7.014	2730.286	1743.13	2730.286	9.999+	1.566
132	17	S4	0	4.748	2716.88	1739.424	2716.88	9.999+	1.562
133	17	S5	0	.041	2720.866	1734.603	2720.866	9.999+	1.569
134	17	S6	0	4.433	2712.695	1710.493	2712.695	9.999+	1.586
135	17	S7	0	20.638	2745.487	1908.714	2745.487	9.999+	1.438
136	17	S8	0	103.866	2495.725	1155.357	2495.725	9.999+	2.16
137	18	S1	0	43.474	2630.542	1469.31	2630.542	9.999+	1.79
138	18	S2	0	.197	2582.511	1499.312	2582.511	9.999+	1.722
139	18	S3	0	5.387	2627.129	1509.781	2627.129	9.999+	1.74
140	18	S4	0	0	2619.163	1507.479	2619.163	9.999+	1.737
141	18	S5	0	4.07	2621.685	1505.971	2621.685	9.999+	1.741
142	18	S6	0	5.559	2612.203	1483.059	2612.203	9.999+	1.761
143	18	S7	0	25.003	2658.062	1658.343	2658.062	9.999+	1.603
144	18	S8	0	74.109	2410.865	998.511	2410.865	9.999+	2.414
145	19	S1	0	23.192	2255.835	625.433	2255.835	9.999+	3.607
146	19	S2	0	.509	2195.291	557.165	2195.291	9.999+	3.94
147	19	S3	0	4.262	2149.644	402.282	2149.644	9.999+	5.344
148	19	S4	0	0	2078.418	247.127	2078.418	9.999+	8.41
149	19	S5	0	.637	2079.193	242.174	2079.193	9.999+	8.586
150	19	S6	0	.832	2077.718	240.826	2077.718	9.999+	8.627
151	19	S7	0	3.888	2081.699	267.993	2081.699	9.999+	7.768
152	19	S8	0	24.437	2037.251	162.657	2037.251	9.999+	9.999+
153	20	S1	0	15.628	1697.458	624.741	1697.458	9.999+	2.717
154	20	S2	0	2.097	1772.773	494.739	1772.773	9.999+	3.583
155	20	S3	0	1.898	1826.493	340.75	1826.493	9.999+	5.36



Company : Vector Structural Engineering  
 Designer : STB  
 Job Number : U2716.091.181  
 Model Name : Ground Mount

July 23, 2019  
 11:04 AM  
 Checked By: JSP

**Slab Sliding Safety Factors (By Combination) (Continued)**

	LC	Slab	Angle[deg]	Va-xx[lb]	Vr-xx[lb]	Va-zz[lb]	Vr-zz[lb]	SR-xx	SR-zz
156	20	S4	0	0	1867.439	249.306	1867.439	9.999+	7.491
157	20	S5	0	.685	1869.298	242.552	1869.298	9.999+	7.707
158	20	S6	0	.8	1868.826	240.749	1868.826	9.999+	7.763
159	20	S7	0	1.309	1871.572	268.001	1871.572	9.999+	6.983
160	20	S8	0	11.769	1880.879	162.659	1880.879	9.999+	9.999+

**Envelope Slab Soil Pressures**

	Label	UC	LC	Soil Pressure[psf]	Allowable Bearing[psf]	Point
1	S1	.574	5	861.122	1500	N226
2	S2	.548	5	822.397	1500	N233
3	S3	.57	5	854.732	1500	N240
4	S4	.566	5	848.538	1500	N247
5	S5	.565	5	846.911	1500	N254
6	S6	.562	5	843.545	1500	N261
7	S7	.581	5	871.819	1500	N268
8	S8	.487	5	730.8	1500	N275





Company:		Date:	5/14/2018
Engineer:		Page:	1/6
Project:			
Address:			
Phone:			
E-mail:			

**1. Project information**

Customer company:  
Customer contact name:  
Customer e-mail:  
Comment:

Project description:  
Location:  
Fastening description:

**2. Input Data & Anchor Parameters**

**General**

Design method: ACI 318-14  
Units: Imperial units

**Anchor Information:**

Anchor type: Bonded anchor  
Material: F1554 Grade 36  
Diameter (inch): 0.375  
Effective Embedment depth,  $h_{ef}$  (inch): 6.000  
Code report: ICC-ES ESR-4057  
Anchor category: -  
Anchor ductility: Yes  
 $h_{min}$  (inch): 7.25  
 $c_{ac}$  (inch): 10.99  
 $c_{min}$  (inch): 1.75  
 $s_{min}$  (inch): 3.00

**Base Material**

Concrete: Normal-weight  
Concrete thickness,  $h$  (inch): 30.00  
State: Cracked  
Compressive strength,  $f'_c$  (psi): 2500  
 $\Psi_{c,v}$ : 1.0  
Reinforcement condition: B tension, B shear  
Supplemental reinforcement: Not applicable  
Reinforcement provided at corners: No  
Ignore concrete breakout in tension: No  
Ignore concrete breakout in shear: No  
Hole condition: Dry concrete  
Inspection: Periodic  
Temperature range, Short/Long: 150/110°F  
Ignore 6do requirement: Not applicable  
Build-up grout pad: No

**Base Plate**

Length x Width x Thickness (inch): 4.75 x 4.75 x 0.31

**Recommended Anchor**

Anchor Name: SET-3G - SET-3G w/ 3/8"Ø F1554 Gr. 36  
Code Report: ICC-ES ESR-4057





Company:		Date:	5/14/2018
Engineer:		Page:	2/6
Project:			
Address:			
Phone:			
E-mail:			

**Load and Geometry**

Load factor source: ACI 318 Section 5.3

Load combination: not set

Seismic design: No

Anchors subjected to sustained tension: No

Apply entire shear load at front row: No

Anchors only resisting wind and/or seismic loads: No

Strength level loads:

$N_{ua}$  [lb]: 4735

$V_{uax}$  [lb]: 175

$V_{uay}$  [lb]: -3330

$M_{ux}$  [ft-lb]: 0

$M_{uy}$  [ft-lb]: 0

$M_{uz}$  [ft-lb]: 0

<Figure 1>

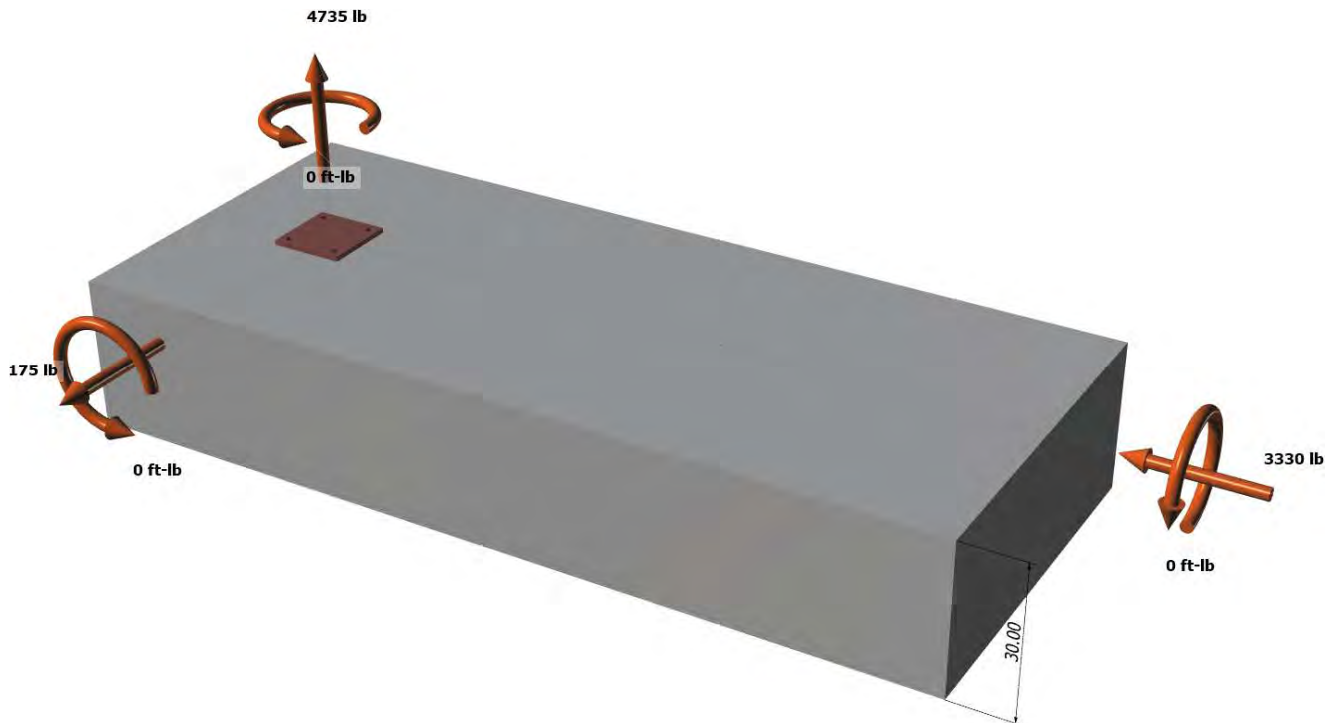



Company:		Date:	5/14/2018
Engineer:		Page:	3/6
Project:			
Address:			
Phone:			
E-mail:			

<Figure 2>





Company:		Date:	5/14/2018
Engineer:		Page:	4/6
Project:			
Address:			
Phone:			
E-mail:			

### 3. Resulting Anchor Forces

Anchor	Tension load, $N_{ua}$ (lb)	Shear load x, $V_{uax}$ (lb)	Shear load y, $V_{uay}$ (lb)	Shear load combined, $\sqrt{(V_{uax})^2 + (V_{uay})^2}$ (lb)
1	1183.8	43.7	-832.5	833.6
2	1183.8	43.7	-832.5	833.6
3	1183.8	43.7	-832.5	833.6
4	1183.8	43.7	-832.5	833.6
Sum	4735.0	175.0	-3330.0	3334.6

Maximum concrete compression strain (%): 0.00  
 Maximum concrete compression stress (psi): 0  
 Resultant tension force (lb): 4735  
 Resultant compression force (lb): 0  
 Eccentricity of resultant tension forces in x-axis,  $e'_{Nx}$  (inch): 0.00  
 Eccentricity of resultant tension forces in y-axis,  $e'_{Ny}$  (inch): 0.00  
 Eccentricity of resultant shear forces in x-axis,  $e'_{Vx}$  (inch): 0.00  
 Eccentricity of resultant shear forces in y-axis,  $e'_{Vy}$  (inch): 0.00

<Figure 3>

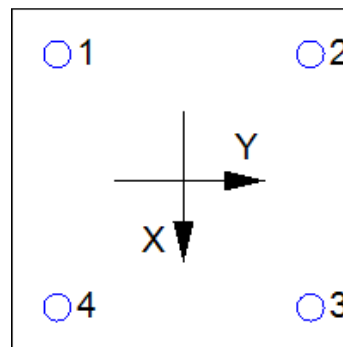

### 4. Steel Strength of Anchor in Tension (Sec. 17.4.1)

$N_{sa}$ (lb)	$\phi$	$\phi N_{sa}$ (lb)
4525	0.75	3394

### 5. Concrete Breakout Strength of Anchor in Tension (Sec. 17.4.2)

$$N_b = K_c \lambda_a \sqrt{f_c} h_{ef}^{1.5} \text{ (Eq. 17.4.2.2a)}$$

$K_c$	$\lambda_a$	$f_c$ (psi)	$h_{ef}$ (in)	$N_b$ (lb)
17.0	1.00	2500	6.000	12492

$$\phi N_{cbg} = \phi (A_{Nc} / A_{Nco}) \psi_{ec,N} \psi_{ed,N} \psi_{c,N} \psi_{cp,N} N_b \text{ (Sec. 17.3.1 \& Eq. 17.4.2.1b)}$$

$A_{Nc}$ (in <sup>2</sup> )	$A_{Nco}$ (in <sup>2</sup> )	$c_{a,min}$ (in)	$\psi_{ec,N}$	$\psi_{ed,N}$	$\psi_{c,N}$	$\psi_{cp,N}$	$N_b$ (lb)	$\phi$	$\phi N_{cbg}$ (lb)
424.63	324.00	7.25	1.000	0.942	1.00	1.000	12492	0.65	10021

### 6. Adhesive Strength of Anchor in Tension (Sec. 17.4.5)

$$\tau_{k,cr} = \tau_{k,cr,short-term} K_{sat} (f_c / 2,500)^n$$

$\tau_{k,cr}$ (psi)	$f_{short-term}$	$K_{sat}$	$f_c$ (psi)	$n$	$\tau_{k,cr}$ (psi)
1346	1.00	1.00	2500	0.24	1346

$$N_{ba} = \lambda_a \tau_{cr} \pi d_a h_{ef} \text{ (Eq. 17.4.5.2)}$$

$\lambda_a$	$\tau_{cr}$ (psi)	$d_a$ (in)	$h_{ef}$ (in)	$N_{ba}$ (lb)
1.00	1346	0.38	6.000	9514

$$\phi N_{ag} = \phi (A_{Na} / A_{Na0}) \psi_{ec,Na} \psi_{ed,Na} \psi_{cp,Na} N_{ba} \text{ (Sec. 17.3.1 \& Eq. 17.4.5.1b)}$$

$A_{Na}$ (in <sup>2</sup> )	$A_{Na0}$ (in <sup>2</sup> )	$c_{Na}$ (in)	$c_{a,min}$ (in)	$\psi_{ec,Na}$	$\psi_{ed,Na}$	$\psi_{cp,Na}$	$N_{ba}$ (lb)	$\phi$	$\phi N_{ag}$ (lb)
198.45	112.09	5.29	7.25	1.000	1.000	1.000	9514	0.55	9265



Company:		Date:	5/14/2018
Engineer:		Page:	5/6
Project:			
Address:			
Phone:			
E-mail:			

**8. Steel Strength of Anchor in Shear (Sec. 17.5.1)**

$V_{sa}$ (lb)	$\phi_{grout}$	$\phi$	$\phi_{grout}\phi V_{sa}$ (lb)
2715	1.0	0.65	1765

**9. Concrete Breakout Strength of Anchor in Shear (Sec. 17.5.2)**

**Shear perpendicular to edge in x-direction:**

$V_{bx} = \min|7(l_e / d_a)^{0.2} \sqrt{d_a} \lambda_a \sqrt{f_c} c_{a1}^{1.5}; 9 \lambda_a \sqrt{f_c} c_{a1}^{1.5}|$  (Eq. 17.5.2.2a & Eq. 17.5.2.2b)

$l_e$ (in)	$d_a$ (in)	$\lambda_a$	$f_c$ (psi)	$c_{a1}$ (in)	$V_{bx}$ (lb)
3.00	0.375	1.00	2500	13.75	16564

$\phi V_{cbgx} = \phi (A_{Vc} / A_{Vco}) \psi_{ec,v} \psi_{ed,v} \psi_{c,v} \psi_{h,v} V_{bx}$  (Sec. 17.3.1 & Eq. 17.5.2.1b)

$A_{Vc}$ (in <sup>2</sup> )	$A_{Vco}$ (in <sup>2</sup> )	$\psi_{ec,v}$	$\psi_{ed,v}$	$\psi_{c,v}$	$\psi_{h,v}$	$V_{bx}$ (lb)	$\phi$	$\phi V_{cbgx}$ (lb)
647.11	850.78	1.000	0.805	1.000	1.000	16564	0.70	7103

**Shear perpendicular to edge in y-direction:**

$V_{by} = \min|7(l_e / d_a)^{0.2} \sqrt{d_a} \lambda_a \sqrt{f_c} c_{a1}^{1.5}; 9 \lambda_a \sqrt{f_c} c_{a1}^{1.5}|$  (Eq. 17.5.2.2a & Eq. 17.5.2.2b)

$l_e$ (in)	$d_a$ (in)	$\lambda_a$	$f_c$ (psi)	$c_{a1}$ (in)	$V_{by}$ (lb)
3.00	0.375	1.00	2500	10.75	11450

$\phi V_{cbgy} = \phi (A_{Vc} / A_{Vco}) \psi_{ec,v} \psi_{ed,v} \psi_{c,v} \psi_{h,v} V_{by}$  (Sec. 17.3.1 & Eq. 17.5.2.1b)

$A_{Vc}$ (in <sup>2</sup> )	$A_{Vco}$ (in <sup>2</sup> )	$\psi_{ec,v}$	$\psi_{ed,v}$	$\psi_{c,v}$	$\psi_{h,v}$	$V_{by}$ (lb)	$\phi$	$\phi V_{cbgy}$ (lb)
387.00	520.03	1.000	0.891	1.000	1.000	11450	0.70	5313

**Shear parallel to edge in x-direction:**

$V_{by} = \min|7(l_e / d_a)^{0.2} \sqrt{d_a} \lambda_a \sqrt{f_c} c_{a1}^{1.5}; 9 \lambda_a \sqrt{f_c} c_{a1}^{1.5}|$  (Eq. 17.5.2.2a & Eq. 17.5.2.2b)

$l_e$ (in)	$d_a$ (in)	$\lambda_a$	$f_c$ (psi)	$c_{a1}$ (in)	$V_{by}$ (lb)
3.00	0.375	1.00	2500	7.25	6342

$\phi V_{cbgx} = \phi (2)(A_{Vc} / A_{Vco}) \psi_{ec,v} \psi_{ed,v} \psi_{c,v} \psi_{h,v} V_{by}$  (Sec. 17.3.1, 17.5.2.1(c) & Eq. 17.5.2.1b)

$A_{Vc}$ (in <sup>2</sup> )	$A_{Vco}$ (in <sup>2</sup> )	$\psi_{ec,v}$	$\psi_{ed,v}$	$\psi_{c,v}$	$\psi_{h,v}$	$V_{by}$ (lb)	$\phi$	$\phi V_{cbgx}$ (lb)
261.00	236.53	1.000	1.000	1.000	1.000	6342	0.70	9797

**Shear parallel to edge in y-direction:**

$V_{bx} = \min|7(l_e / d_a)^{0.2} \sqrt{d_a} \lambda_a \sqrt{f_c} c_{a1}^{1.5}; 9 \lambda_a \sqrt{f_c} c_{a1}^{1.5}|$  (Eq. 17.5.2.2a & Eq. 17.5.2.2b)

$l_e$ (in)	$d_a$ (in)	$\lambda_a$	$f_c$ (psi)	$c_{a1}$ (in)	$V_{bx}$ (lb)
3.00	0.375	1.00	2500	10.25	10661

$\phi V_{cbgy} = \phi (2)(A_{Vc} / A_{Vco}) \psi_{ec,v} \psi_{ed,v} \psi_{c,v} \psi_{h,v} V_{bx}$  (Sec. 17.3.1, 17.5.2.1(c) & Eq. 17.5.2.1b)

$A_{Vc}$ (in <sup>2</sup> )	$A_{Vco}$ (in <sup>2</sup> )	$\psi_{ec,v}$	$\psi_{ed,v}$	$\psi_{c,v}$	$\psi_{h,v}$	$V_{bx}$ (lb)	$\phi$	$\phi V_{cbgy}$ (lb)
401.67	472.78	1.000	1.000	1.000	1.000	10661	0.70	12680

**10. Concrete Pryout Strength of Anchor in Shear (Sec. 17.5.3)**

$\phi V_{cp} = \phi \min|k_{cp} N_{ag}; k_{cp} N_{cbg}| = \phi \min|k_{cp} (A_{Na} / A_{Na0}) \psi_{ec,Na} \psi_{ed,Na} \psi_{cp,Na} N_{ba}; k_{cp} (A_{Nc} / A_{Nco}) \psi_{ec,N} \psi_{ed,N} \psi_{c,N} \psi_{cp,N} N_b|$  (Sec. 17.3.1 & Eq. 17.5.3.1b)

$k_{cp}$	$A_{Na}$ (in <sup>2</sup> )	$A_{Na0}$ (in <sup>2</sup> )	$\psi_{ed,Na}$	$\psi_{ec,Na}$	$\psi_{cp,Na}$	$N_{ba}$ (lb)	$N_a$ (lb)
2.0	198.45	112.09	1.000	1.000	1.000	9514	16845

$A_{Nc}$ (in <sup>2</sup> )	$A_{Nco}$ (in <sup>2</sup> )	$\psi_{ec,N}$	$\psi_{ed,N}$	$\psi_{c,N}$	$\psi_{cp,N}$	$N_b$ (lb)	$N_{cb}$ (lb)	$\phi$
424.63	324.00	1.000	0.942	1.000	1.000	12492	15417	0.70

Input data and results must be checked for agreement with the existing circumstances, the standards and guidelines must be checked for plausibility.



Company:		Date:	5/14/2018
Engineer:		Page:	6/6
Project:			
Address:			
Phone:			
E-mail:			

$\phi V_{cpq}$  (lb)  
21584

## 11. Results

### Interaction of Tensile and Shear Forces (Sec. R17.6)

Tension	Factored Load, $N_{ua}$ (lb)	Design Strength, $\phi N_n$ (lb)	Ratio	Status	
Steel	1184	3394	0.35	Pass	
Concrete breakout	4735	10021	0.47	Pass	
<b>Adhesive</b>	<b>4735</b>	<b>9265</b>	<b>0.51</b>	<b>Pass (Governs)</b>	
Shear	Factored Load, $V_{ua}$ (lb)	Design Strength, $\phi V_n$ (lb)	Ratio	Status	
Steel	834	1765	0.47	Pass	
T Concrete breakout x+	175	7103	0.02	Pass	
T Concrete breakout y-	3330	5313	0.63	Pass	
Concrete breakout y-	87	9797	0.01	Pass	
Concrete breakout x-	1665	12680	0.13	Pass	
<b>Concrete breakout, combined</b>	-	-	<b>0.63</b>	<b>Pass (Governs)</b>	
Pryout	3335	21584	0.15	Pass	
Interaction check	$(N_{ua}/\phi N_{ua})^{5/3}$	$(V_{ua}/\phi V_{ua})^{5/3}$	Combined Ratio	Permissible	Status
Sec. R17.6	0.33	0.46	78.6%	1.0	Pass

**SET-3G w/ 3/8"Ø F1554 Gr. 36 with hef = 6.000 inch meets the selected design criteria.**

## 12. Warnings

- Designer must exercise own judgement to determine if this design is suitable.
- Refer to manufacturer's product literature for hole cleaning and installation instructions.



JOB NO.: U2716-070-181

DESIGNED: STB

PROJECT: Ground Mount Package for Ontario Canada

---

# Framing Analysis



Vector Structural Engineeri...	Ground Mount	SK - 4
STB		July 22, 2019 at 11:22 AM
U2716.091.191		New England A1 v5.r3d



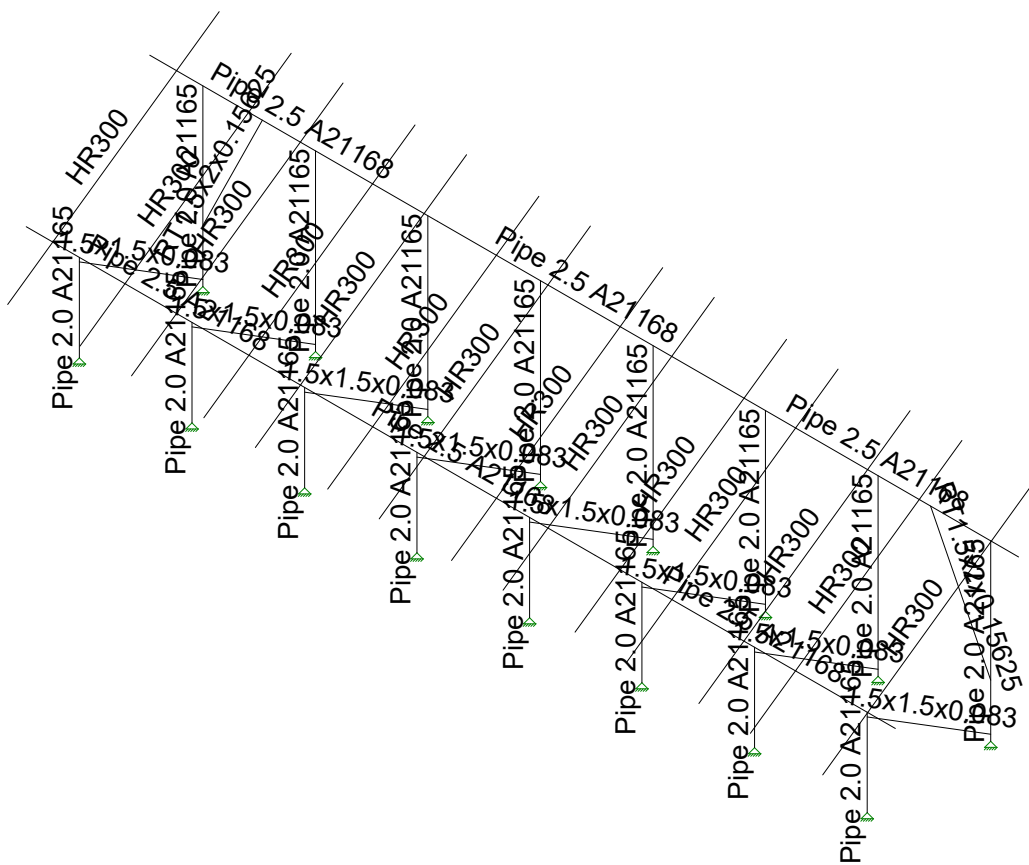

Vector Structural Engineeri...	Ground Mount	SK - 5
STB		July 22, 2019 at 11:22 AM
U2716.091.191		New England A1 v5.r3d

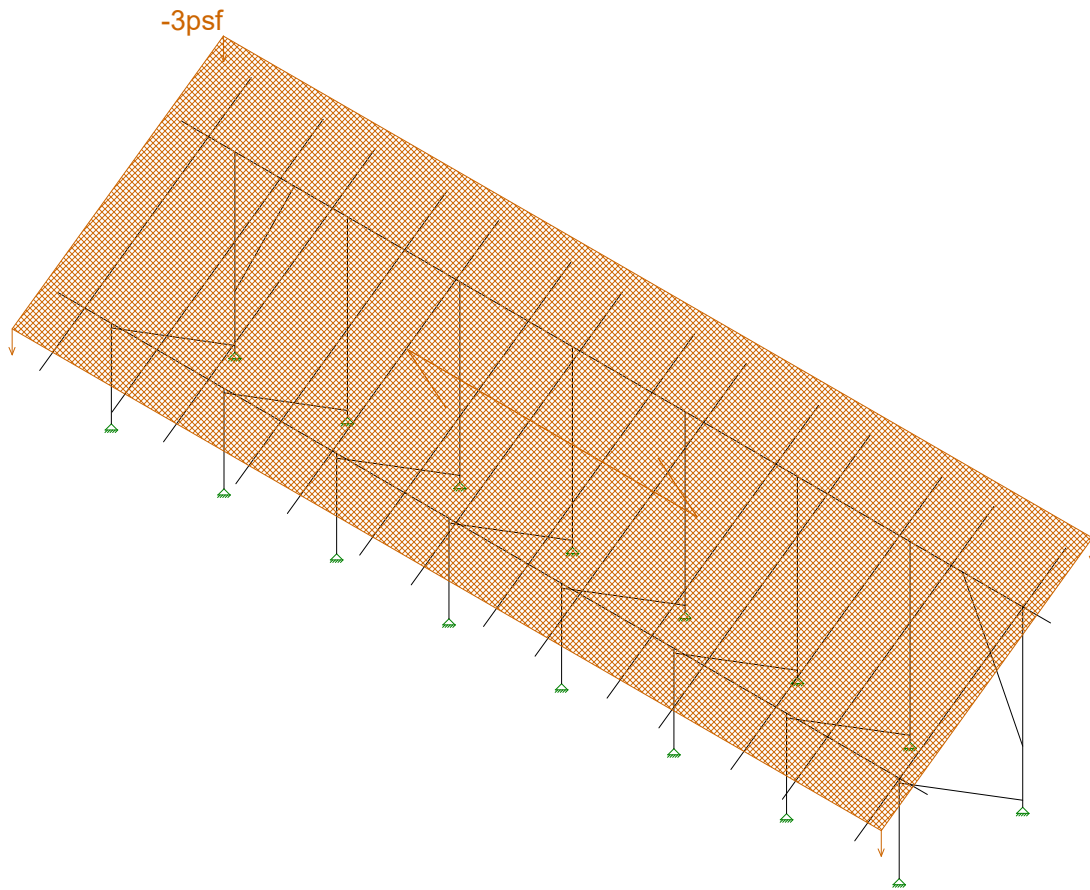

Loads: BLC 2, Solar Panel Weight

Vector Structural Engineeri...

STB

U2716.091.191

Ground Mount

SK - 6

July 22, 2019 at 11:22 AM

New England A1 v5.r3d

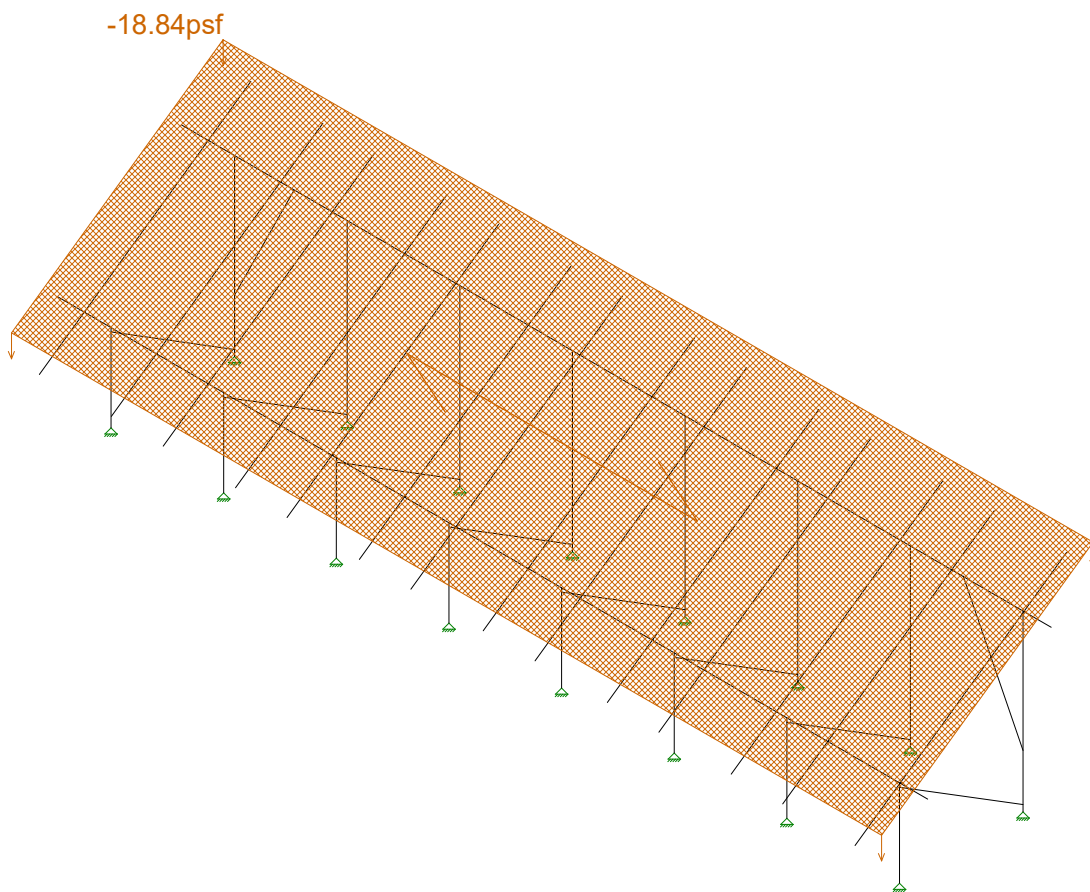

Loads: BLC 3, Roof Live/Snow

Vector Structural Engineeri..

STB

U2716.091.191

Ground Mount

SK - 3

July 23, 2019 at 11:10 AM

New England A1 v5.r3d

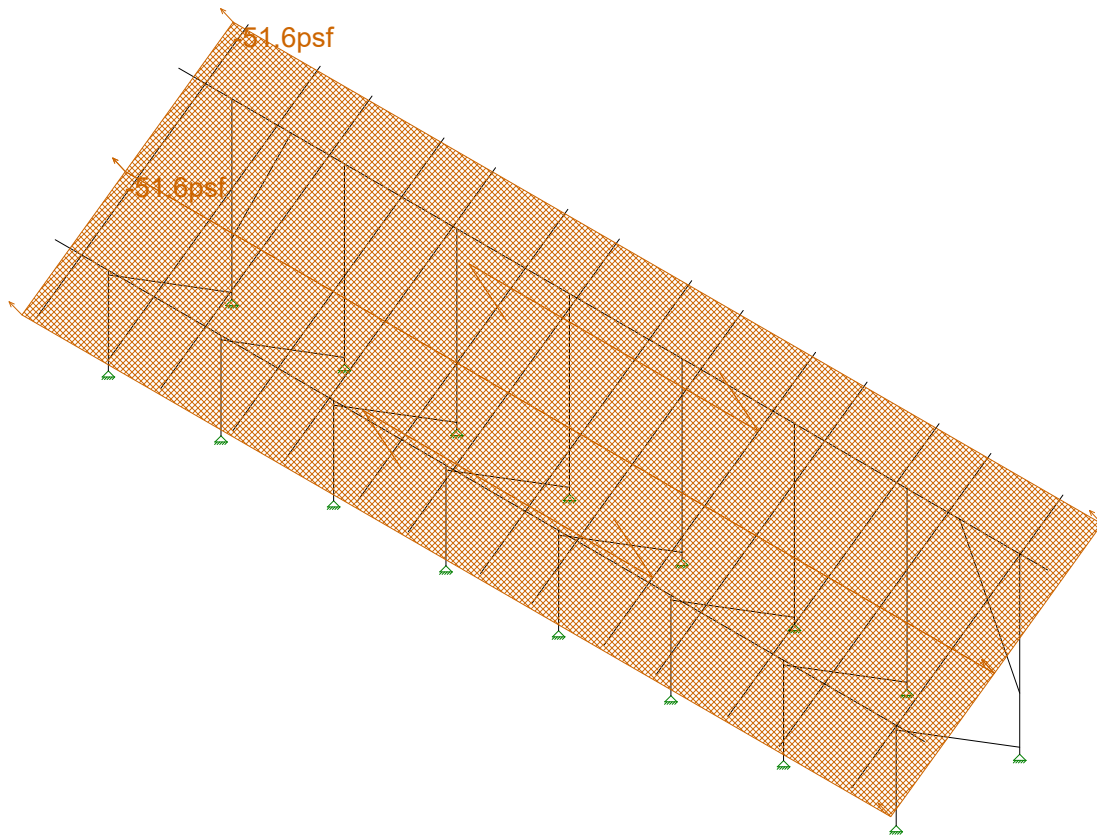

Loads: BLC 4, Wind A 0 deg

Vector Structural Engineeri..

STB

U2716.091.191

Ground Mount

SK - 8

July 22, 2019 at 11:23 AM

New England A1 v5.r3d

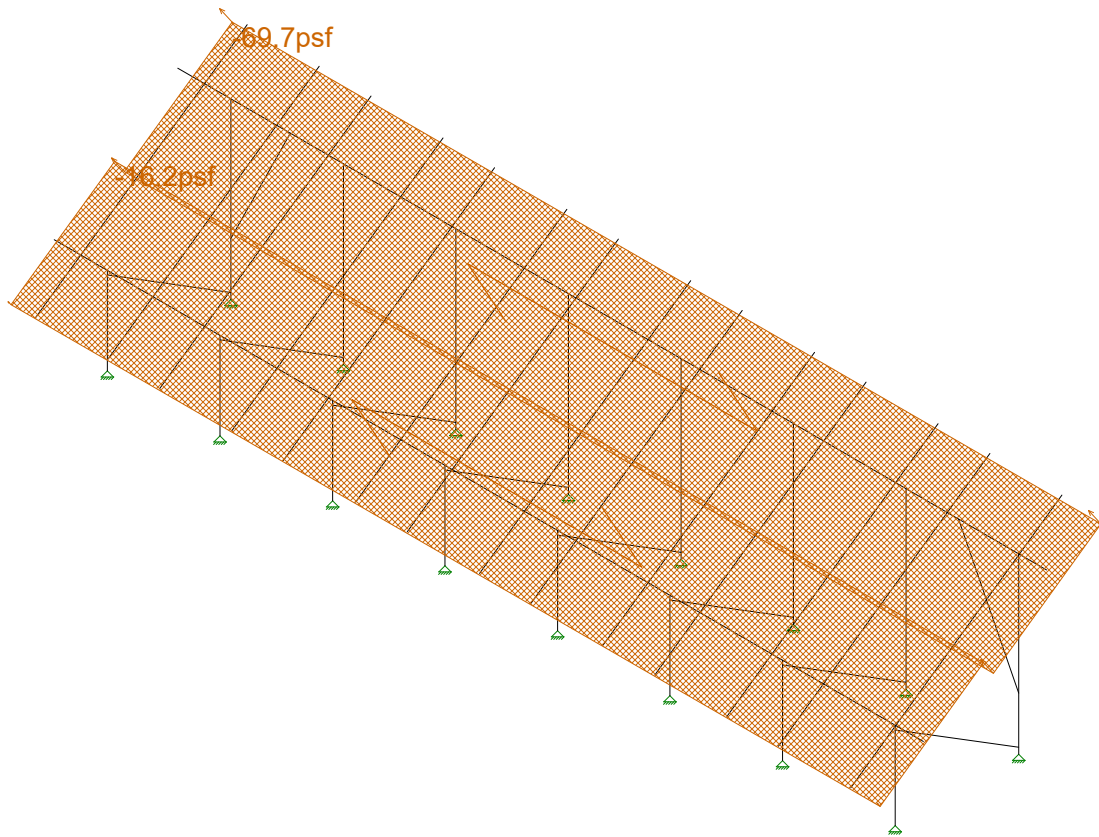

Loads: BLC 5, Wind B 0 deg

Vector Structural Engineeri..

STB

U2716.091.191

Ground Mount

SK - 9

July 22, 2019 at 11:23 AM

New England A1 v5.r3d

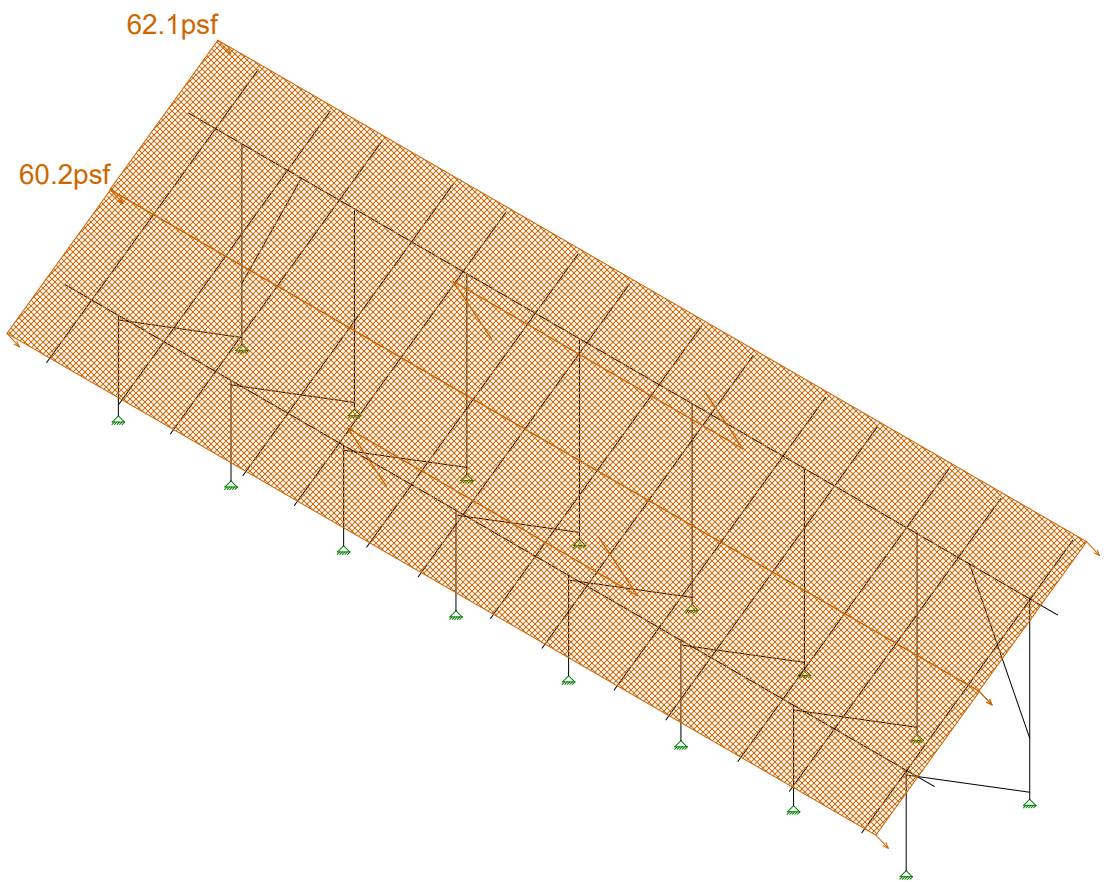

Loads: BLC 6, Wind A 180 deg

Vector Structural Engineeri..	Ground Mount	SK - 10
STB		July 22, 2019 at 11:23 AM
U2716.091.191		New England A1 v5.r3d

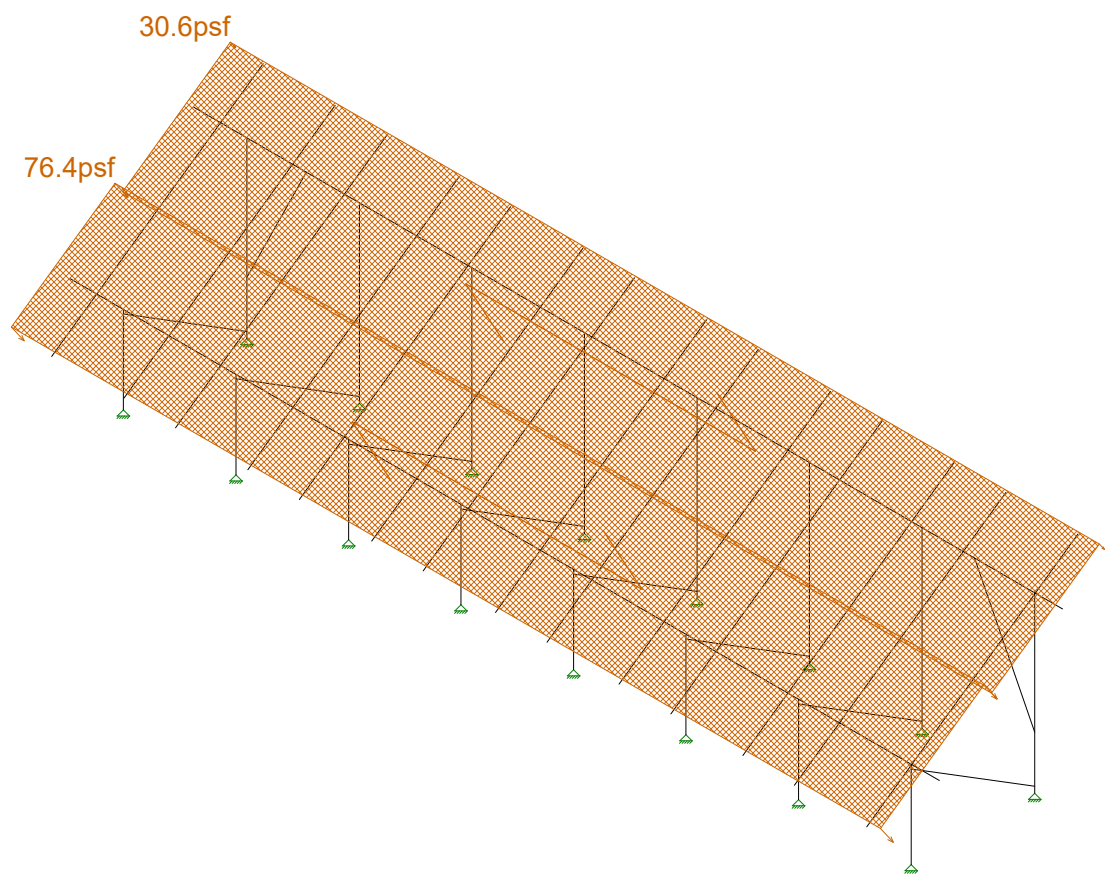

Loads: BLC 7, Wind B 180 deg

Vector Structural Engineeri..	Ground Mount	SK - 11
STB		July 22, 2019 at 11:23 AM
U2716.091.191		New England A1 v5.r3d

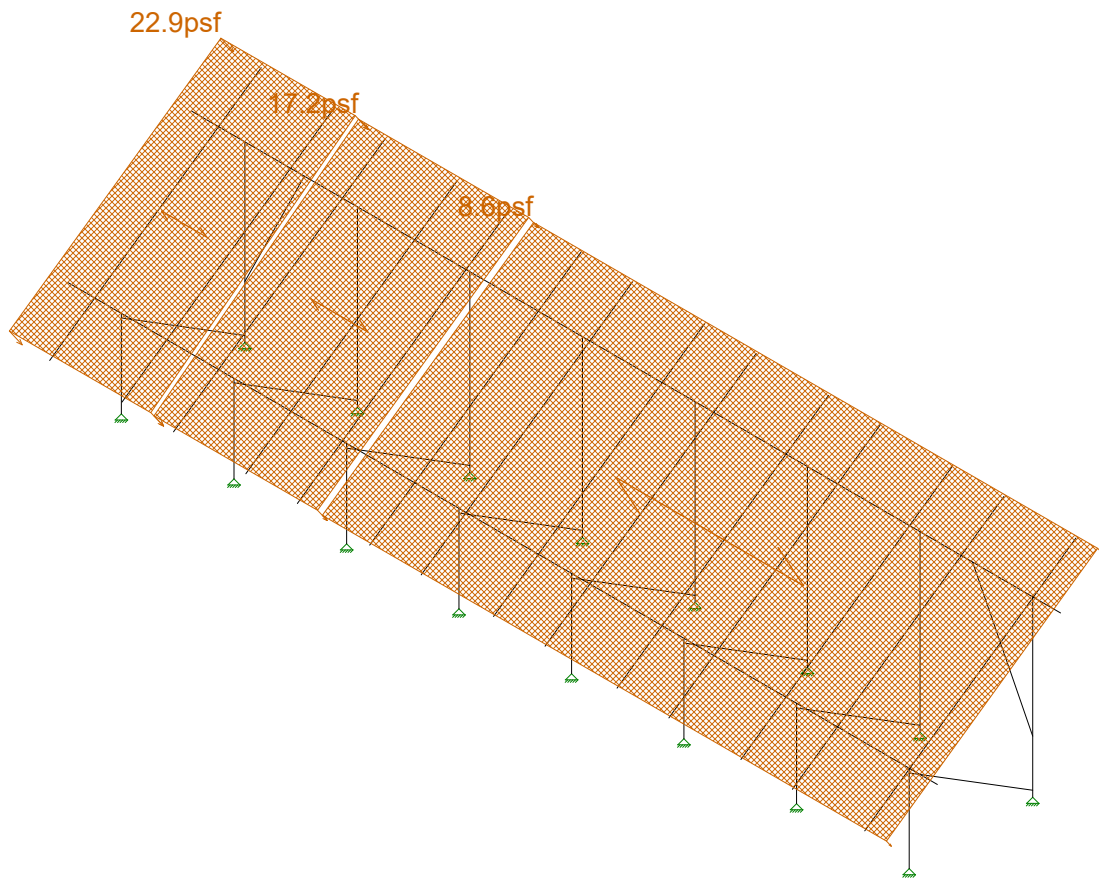

Loads: BLC 8, Wind A 90

Vector Structural Engineeri...	Ground Mount	SK - 12
STB		July 22, 2019 at 11:23 AM
U2716.091.191		New England A1 v5.r3d



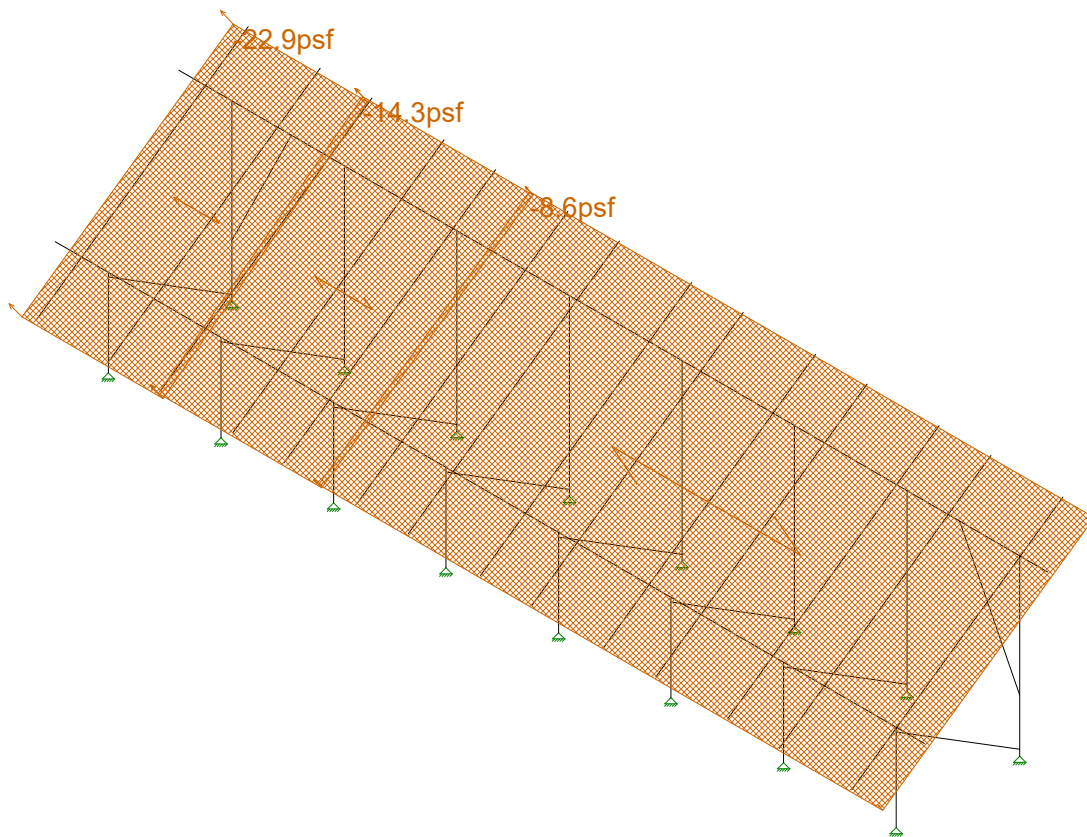

Loads: BLC 9, Wind B 90

Vector Structural Engineeri...	Ground Mount	SK - 13
STB		July 22, 2019 at 11:23 AM
U2716.091.191		New England A1 v5.r3d



Code Check  
(Enr)  
No Calc  
> 1.0  
40-1.0  
75-90  
50-75  
0-.50

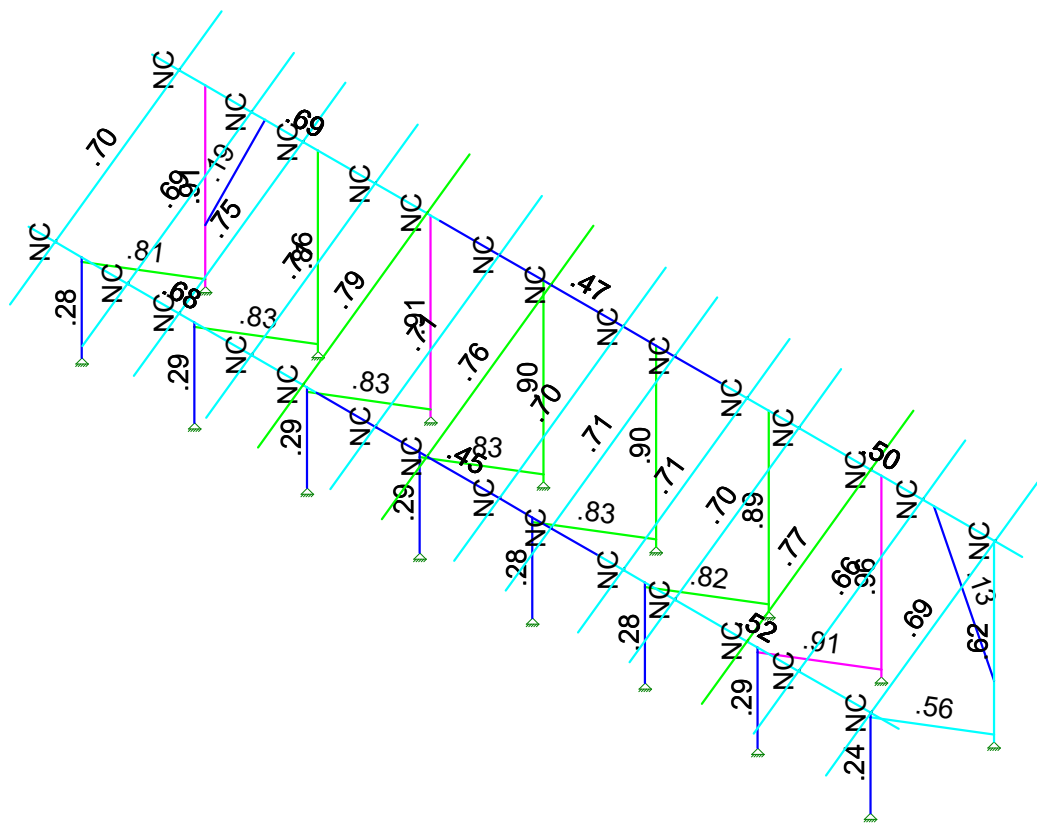

Member Code Checks Displayed (Enveloped)  
Envelope Only Solution

Vector Structural Engineeri...	Ground Mount	SK - 1
STB		July 23, 2019 at 11:09 AM
U2716.091.191		New England A1 v5.r3d







**(Global) Model Settings, Continued**

Seismic Code	ASCE 7-10
Seismic Base Elevation (in)	15600
Add Base Weight?	Yes
Ct X	.02
Ct Z	.02
T X (sec)	Not Entered
T Z (sec)	Not Entered
R X	3
R Z	3
Ct Exp. X	.75
Ct Exp. Z	.75
SD1	1
SDS	1
S1	1
TL (sec)	5
Risk Cat	I or II
Drift Cat	Other
Om Z	1
Om X	1
Cd Z	4
Cd X	4
Rho Z	1
Rho X	1

**Hot Rolled Steel Properties**

	Label	E [ksi]	G [ksi]	Nu	Therm (1E5 F)	Density[lb/ft^3]	Yield[psi]	Ry	Fu[psi]	Rt
1	A992	29000	11154	.3	.65	490	50000	1.1	65000	1.1
2	A36 Gr.36	29000	11154	.3	.65	490	36000	1.5	58000	1.2
3	A572 Gr.50	29000	11154	.3	.65	490	50000	1.1	65000	1.1
4	A500 Gr.B R...	29000	11154	.3	.65	527	42000	1.4	58000	1.3
5	A500 Gr.B Re...	29000	11154	.3	.65	527	46000	1.4	58000	1.3
6	A53 Gr.B	29000	11154	.3	.65	490	35000	1.6	60000	1.2
7	A1085	29000	11154	.3	.65	490	50000	1.4	65000	1.3

**Aluminum Properties**

	Label	E [ksi]	G [ksi]	Nu	Therm (...Density[... Table B.4	kt	Ftu[psi]	Fty[psi]	Fcy[psi]	Fsu[psi]	Ct
1	3003-H14	10100	3787.5	.33	1.3 172.8 Table B.4-1	1	19000	16000	13000	12000	141
2	6061-T6	10100	3787.5	.33	1.3 172.8 Table B.4-2	1	38000	35000	35000	24000	141
3	6063-T5	10100	3787.5	.33	1.3 172.8 Table B.4-2	1	22000	16000	16000	13000	141
4	6063-T6	10100	3787.5	.33	1.3 172.8 Table B.4-2	1	30000	25000	25000	19000	141
5	5052-H34	10200	3787.5	.33	1.3 172.8 Table B.4-1	1	34000	26000	24000	20000	141
6	6061-T6 W	10100	3787.5	.33	1.3 172.8 Table B.4-1	1	24000	15000	15000	15000	141
7	6005-T5	10100	3787.5	.33	1.3 172.8 Table B.4-1	1	38000	35000	35000	24000	141

**Hot Rolled Steel Section Sets**

	Label	Shape	Type	Design List	Material	Design R...	A [in2]	Iyy [in4]	Izz [in4]	J [in4]
1	Post	Pipe 2.0 A21165	Column	Pipe	A572 Gr.50	Typical	.776	.499	.499	.998
2	Cross Beam	Pipe 2.5 A21168	Beam	Wide Flange	A572 Gr.50	Typical	.947	.907	.907	1.814
3	Diagonal Brace	1.5x1.5x0.083	HBrace	SquareTube	A572 Gr.50	Typical	.47	.158	.158	.236



Company : Vector Structural Engineering  
 Designer : STB  
 Job Number : U2716.091.191  
 Model Name : Ground Mount

Aug 7, 2019  
 4:46 PM  
 Checked By: \_\_\_\_\_

**Aluminum Section Sets**

	Label	Shape	Type	Design List	Material	Design R...	A [in2]	Iyy [in4]	Izz [in4]	J [in4]
1	AL Posts	2.375ODX0.188	Column	Pipe	6005-T5	Typical	1.29	.778	.778	1.54
2	AL Brace	RT1.5x2x0.15625	VBrace	Rectangular Tubes	6005-T5	Typical	.996	.327	.524	.602
3	AL Rails	HR300	Beam	Rectangular Tubes	6005-T5	Typical	.736	.214	.727	.614
4	AL Cross Beam	Cross Rail	Beam	Rectangular Tubes	6005-T5	Typical	1.909	1.97	4.366	4.017

**Member Area Loads (BLC 2 : Solar Panel Weight)**

	Joint A	Joint B	Joint C	Joint D	Direction	Distribution	Magnitude[psf]
1	N197	N200	N199	N196	Y	A-B	-3

**Member Area Loads (BLC 3 : Roof Live/Snow)**

	Joint A	Joint B	Joint C	Joint D	Direction	Distribution	Magnitude[psf]
1	N197	N200	N199	N196	PY	A-B	-23

**Member Area Loads (BLC 4 : Wind A 0 deg)**

	Joint A	Joint B	Joint C	Joint D	Direction	Distribution	Magnitude[psf]
1	N197	N200	N201	N198	Perp	A-B	-51.6
2	N198	N201	N199	N196	Perp	A-B	-51.6

**Member Area Loads (BLC 5 : Wind B 0 deg)**

	Joint A	Joint B	Joint C	Joint D	Direction	Distribution	Magnitude[psf]
1	N197	N200	N201	N198	Perp	A-B	-69.7
2	N198	N201	N199	N196	Perp	A-B	-16.2

**Member Area Loads (BLC 6 : Wind A 180 deg)**

	Joint A	Joint B	Joint C	Joint D	Direction	Distribution	Magnitude[psf]
1	N197	N200	N201	N198	Perp	A-B	62.1
2	N198	N201	N199	N196	Perp	A-B	60.2

**Member Area Loads (BLC 7 : Wind B 180 deg)**

	Joint A	Joint B	Joint C	Joint D	Direction	Distribution	Magnitude[psf]
1	N197	N200	N201	N198	Perp	A-B	30.6
2	N198	N201	N199	N196	Perp	A-B	76.4

**Member Area Loads (BLC 8 : Wind A 90)**

	Joint A	Joint B	Joint C	Joint D	Direction	Distribution	Magnitude[psf]
1	N197	N203	N202	N196	Perp	A-B	22.9
2	N203	N209	N208	N202	Perp	A-B	17.2
3	N209	N200	N199	N208	Perp	A-B	8.6

**Member Area Loads (BLC 9 : Wind B 90)**

	Joint A	Joint B	Joint C	Joint D	Direction	Distribution	Magnitude[psf]
1	N197	N203	N202	N196	Perp	A-B	-22.9
2	N203	N209	N208	N202	Perp	A-B	-14.3
3	N209	N200	N199	N208	Perp	A-B	-8.6

**Basic Load Cases**

	BLC Description	Category	X Gravity	Y Gravity	Z Gravity	Joint	Point	Distributed	Area(M...Surface...
1	Self Weight	DL		-1.05					
2	Solar Panel Weight	DL							1





Company : Vector Structural Engineering  
 Designer : STB  
 Job Number : U2716.091.191  
 Model Name : Ground Mount

Aug 7, 2019  
 4:46 PM  
 Checked By: \_\_\_\_\_

**Envelope Joint Reactions (Continued)**

Joint	X [lb]	LC	Y [lb]	LC	Z [lb]	LC	MX [lb-ft]	LC	MY [lb-ft]	LC	MZ [lb-ft]	LC
14	min	-6.611	11	-2787.225	16	-1546.65	3	0	1	0	1	0
15	N122	max	1.927	15	1611.144	10	74.661	3	0	1	0	1
16		min	-2.617	13	-482.764	17	-86.296	5	0	1	0	1
17	N133B	max	.642	20	3253.447	5	1826.4...	5	0	1	0	1
18		min	-1.714	12	-2733.335	16	-1541....	3	0	1	0	1
19	N134B	max	8.23	10	1601.408	10	74.598	3	0	1	0	1
20		min	-4.117	17	-485.039	17	-86.152	5	0	1	0	1
21	N151	max	1.854	10	3214.929	5	1795.8...	5	0	1	0	1
22		min	-2.383	11	-2705.223	16	-1516....	3	0	1	0	1
23	N152	max	9.477	12	1563.733	10	73.626	3	0	1	0	1
24		min	-4.225	15	-465.079	17	-85.213	5	0	1	0	1
25	N157A	max	2.73	10	3443.683	5	1991.8...	5	0	1	0	1
26		min	-1.845	18	-2846.393	16	-1683....	3	0	1	0	1
27	N158A	max	29.847	12	1748.526	10	72.979	3	0	1	0	1
28		min	-15.533	15	-556.01	17	-83.323	5	0	1	0	1
29	N157	max	84.274	16	2317.368	5	1224.0...	5	0	1	0	1
30		min	-81.253	11	-1949.847	16	-1032.8	3	0	1	0	1
31	N158	max	15.826	15	1062.076	10	58.523	3	0	1	0	1
32		min	-31.382	12	-318.18	17	-68.385	5	0	1	0	1
33	Totals:	max	.007	19	26205.692	11	13414....	5				
34		min	-.03	12	-14459.173	15	-11315...	15				

**Envelope AISC 14th(360-10): ASD Steel Code Checks**

Member	Shape	Code Check	Loc[in]	LC	Shear	...	Loc[in]	Dir	LC	Pnc/om	[..Pnt/om	[lb]	Mnyy/om..	Mnzz/om...	Cb	Eqn
1	M5	Pipe 2.0 A2...	.279	52.736	17	.262	53.316		5	16342.406	23232.186	1397.505	1397.505	1...	H1-1b	
2	M6	Pipe 2.0 A2...	.914	3.477	5	.281	0		5	6062.107	23232.186	1397.505	1397.505	1.8	H1-1a	
3	M13	Pipe 2.5 A2...	.678	34.5	6	.193	176....		5	11641.036	28358.413	2081.747	2081.747	2...	H1-1b	
4	M14	Pipe 2.5 A2...	.687	32.583	11	.217	176....		11	11641.036	28358.413	2081.747	2081.747	2...	H1-1b	
5	M15	1.5x1.5x0.083	.814	48.441	5	.027	0	y	5	2744.96	14085.15	624.421	624.421	1...	H1-1a	
6	M80	Pipe 2.0 A2...	.285	52.736	17	.262	53.316		5	16342.406	23232.186	1397.505	1397.505	3.1	H1-1b	
7	M81	Pipe 2.0 A2...	.897	3.477	5	.281	0		5	6062.107	23232.186	1397.505	1397.505	1...	H1-1a	
8	M82	1.5x1.5x0.083	.829	48.441	5	.005	0	y	4	2744.96	14085.15	624.421	624.421	1...	H1-1a	
9	M50	Pipe 2.0 A2...	.288	52.736	17	.262	53.316		5	16342.406	23232.186	1397.505	1397.505	1...	H1-1b	
10	M51	Pipe 2.0 A2...	.864	3.477	5	.280	0		5	6062.107	23232.186	1397.505	1397.505	1...	H1-1a	
11	M52	1.5x1.5x0.083	.826	48.441	5	.010	93.007	y	4	2744.96	14085.15	624.421	624.421	1...	H1-1a	
12	M56A	Pipe 2.0 A2...	.287	52.736	17	.263	53.316		5	16342.406	23232.186	1397.505	1397.505	1...	H1-1b	
13	M57A	Pipe 2.0 A2...	.906	3.477	5	.282	0		5	6062.107	23232.186	1397.505	1397.505	1...	H1-1a	
14	M58A	1.5x1.5x0.083	.831	48.441	5	.006	0	y	13	2744.96	14085.15	624.421	624.421	1...	H1-1a	
15	M68	Pipe 2.0 A2...	.287	52.736	17	.264	53.316		5	16342.406	23232.186	1397.505	1397.505	1...	H1-1b	
16	M69	Pipe 2.0 A2...	.899	3.477	5	.282	0		5	6062.107	23232.186	1397.505	1397.505	1...	H1-1a	
17	M70	1.5x1.5x0.083	.832	48.441	5	.007	0	y	5	2744.96	14085.15	624.421	624.421	1...	H1-1a	
18	M68A	Pipe 2.5 A2...	.447	138.75	6	.164	67.5		5	11641.036	28358.413	2081.747	2081.747	1...	H1-1b	
19	M69A	Pipe 2.5 A2...	.520	102	12	.194	102		5	11641.036	28358.413	2081.747	2081.747	2...	H1-1b	
20	M70A	Pipe 2.5 A2...	.469	138.75	11	.177	67.5		11	11641.036	28358.413	2081.747	2081.747	1...	H1-1b	
21	M71	Pipe 2.5 A2...	.502	30	11	.195	102		5	11641.036	28358.413	2081.747	2081.747	2...	H1-1b	
22	M73	Pipe 2.0 A2...	.284	52.736	17	.258	53.316		5	16342.406	23232.186	1397.505	1397.505	1...	H1-1b	
23	M74	Pipe 2.0 A2...	.887	3.477	5	.278	0		5	6062.107	23232.186	1397.505	1397.505	1...	H1-1a	
24	M75	1.5x1.5x0.083	.818	48.441	5	.004	93.007	y	4	2744.96	14085.15	624.421	624.421	1...	H1-1a	
25	M76	Pipe 2.0 A2...	.289	52.736	17	.290	53.316		5	16342.406	23232.186	1397.505	1397.505	1...	H1-1b	
26	M77	Pipe 2.0 A2...	.964	3.477	5	.309	0		5	6062.107	23232.186	1397.505	1397.505	1...	H1-1a	
27	M78	1.5x1.5x0.083	.907	48.441	5	.010	93.007	y	11	2744.96	14085.15	624.421	624.421	1...	H1-1a	
28	M76A	Pipe 2.0 A2...	.236	52.736	5	.181	53.316		5	16342.406	23232.186	1397.505	1397.505	1...	H1-1b	
29	M77A	Pipe 2.0 A2...	.622	3.477	5	.187	0		5	6062.107	23232.186	1397.505	1397.505	1...	H1-1a	
30	M78A	1.5x1.5x0.083	.561	48.441	5	.040	0	y	11	2744.96	14085.15	624.421	624.421	1...	H1-1a	





Company : Vector Structural Engineering  
 Designer : STB  
 Job Number : U2716.091.191  
 Model Name : Ground Mount

Aug 7, 2019  
 4:46 PM  
 Checked By: \_\_\_\_\_

**Envelope AA ADM1-15: ASD - Building Aluminum Code Checks**

Member	Shape	Code C...	Loc[in]	LC	Shear ...	Loc[in]	Dir	LC	Pnc/O...	Pnt/Om...	Mny/O...	Mnz/O...	Vny/O...	Vnz/O...	Cb	Eqn
1	M19	RT1.5x2x...	.185	52.977	11	.034	0	z	5	2260.001	19411....	770.742	927.083	6090.199	4101.563	1... H.1-1
2	M16	HR300	.700	82.515	5	.098	36.1	y	11	3322.606	14342....	494.953	934.619	6236.364	2843.273	1 H.1-1
3	M35	HR300	.694	130.6...	16	.107	36.1	y	12	3322.606	14342....	494.953	934.619	6236.364	2843.273	1 H.1-1
4	M38	HR300	.746	87.672	16	.100	36.1	y	12	3322.606	14342....	494.953	934.619	6236.364	2843.273	1 H.1-1
5	M41	HR300	.708	36.1	12	.097	36.1	y	12	3322.606	14342....	494.953	934.619	6236.364	2843.273	1 H.1-1
6	M44	HR300	.790	87.672	16	.097	36.1	y	12	3322.606	14342....	494.953	934.619	6236.364	2843.273	1 H.1-1
7	M47	HR300	.707	36.1	12	.098	36.1	y	12	3322.606	14342....	494.953	934.619	6236.364	2843.273	1 H.1-1
8	M50A	HR300	.756	87.672	16	.098	36.1	y	12	3322.606	14342....	494.953	934.619	6236.364	2843.273	1 H.1-1
9	M53	HR300	.705	34.381	12	.097	36.1	y	12	3322.606	14342....	494.953	934.619	6236.364	2843.273	1 H.1-1
10	M56	HR300	.707	36.1	12	.097	36.1	y	12	3322.606	14342....	494.953	934.619	6236.364	2843.273	1 H.1-1
11	M59	HR300	.707	36.1	12	.097	36.1	y	12	3322.606	14342....	494.953	934.619	6236.364	2843.273	1 H.1-1
12	M62	HR300	.705	34.381	12	.097	36.1	y	12	3322.606	14342....	494.953	934.619	6236.364	2843.273	1 H.1-1
13	M65	HR300	.774	87.672	16	.099	36.1	y	12	3322.606	14342....	494.953	934.619	6236.364	2843.273	1 H.1-1
14	M68B	HR300	.661	82.515	11	.108	36.1	y	12	3322.606	14342....	494.953	934.619	6236.364	2843.273	1 H.1-1
15	M71A	HR300	.694	84.234	16	.094	36.1	y	12	3322.606	14342....	494.953	934.619	6236.364	2843.273	1 H.1-1
16	M75B	RT1.5x2x...	.128	53.045	11	.020	0	z	5	2254.199	19411....	770.742	927.083	6090.199	4101.563	1... H.1-1

NOTES: UNLESS OTHERWISE SPECIFIED  
 1. DIMENSIONS SHOWN ARE INCHES [MILIMETERS].

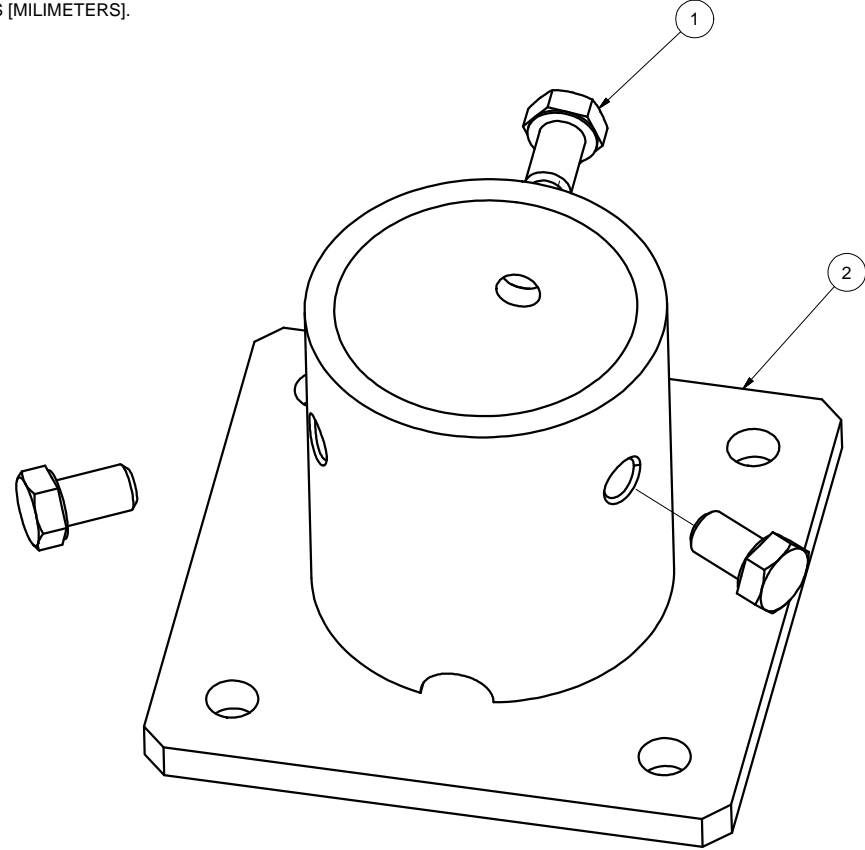

REVISIONS			
REV	DESCRIPTION	BY	DATE
A	INITIAL RELEASE	LWF	10/20/2016

2	A21120-001	2" PIPE BASE	1
1	B15018-011	HEX CAP SCREW 3/8-16 X 5/8	3
ITEM	PART NUMBER	DESCRIPTION	QTY
MATERIAL		SEE NOTES	
Third Angle Projection:			
GENERAL SPECIFICATIONS		<b>Sunmodo Corp.</b> 1905 E 5TH STREET, STE A, VANCOUVER, WA 98661	
Tolerances		TITLE	
X.XXX ±0.01 [0.25mm]		2" PIPE BASE KIT	
X.XX ±0.02 [0.50mm]		DRAWING NUMBER	
X.X ±0.039 [1.0mm]		B K10268-001	
Unless otherwise spec'd		SCALE: NONE	
DRAWN BY		SHEET 1 of 1	
LWF		DATE	
CHECKED BY		10/20/2016	
APPROVALS			

THIS DRAWING IS CONFIDENTIAL PROPERTY OF SUNMODO AND ITS CONTENTS MAY NOT BE DISCLOSED WITHOUT THE PRIOR WRITTEN CONSENT OF SUNMODO CORP.

NOTES: UNLESS OTHERWISE SPECIFIED

1. DIMENSIONS SHOWN ARE INCHES [MILIMETERS].
2. MATERAIL: ALUMINUM 6005-T5.  
FINISH: CLEAR ANODIZED 10  $\mu$ m THICK.
3. THE UNSPECIFIED DIMENSIONS ARE SPECIFIED BY 2D CAD FILE.

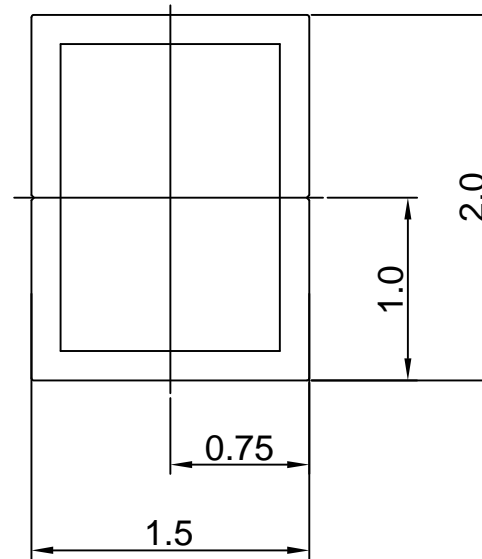

## Section properties:

Weight: 1.156 lbs/ft

Area: 0.992 in<sup>2</sup>

Perimeter: 12.601 in

Bounding Box: X: -1.000,1.000

Y: -0.750, 0.750

Centroid:(0.000,0.000)

Moments of Inertia(in<sup>4</sup>): I<sub>x</sub>=0.506,I<sub>y</sub>=0.322

Section modulus in bending(in<sup>3</sup>): W<sub>x</sub>=0.675,W<sub>y</sub>=0.322

Radii of Gyration: X: 0.714, Y: 0.570

MATERIAL		SEE NOTES	
Third Angle Projection:			
GENERAL SPECIFICATIONS			
All Dimensions in inches [millimeters]			
Tolerances			
X.XXX ± 0.01 [0.25mm]		Break all sharp edges	
X.XX ± 0.02 [0.50mm]		.010-.020 unless	
X.X ± 0.039 [1.0mm]		otherwise specified.	
Unless otherwise specd			
DRAWN BY	DATE	TITLE	
zcg	03/12/2014	1905 E 5TH STREET, SUITE A, VANCOUVER, WA 98661	
CHECKED BY		B	DRAWING NUMBER
			A20164
APPROVALS		SCALE:	SHEET 1 of 1
		NONE	

**Sunmodo Corp.**

1905 E 5TH STREET, SUITE A, VANCOUVER, WA 98661

TITLE  
1.5X2 AL TUBE BRACE EXTRUSION

DRAWING NUMBER  
A20164

SCALE: NONE SHEET 1 of 1

REVISIONS			
REV	DESCRIPTION	BY	DATE
A	ADDED BOTTOM CHANNEL & CHANGED ONE 3/8 CHANNEL TO 1/4	zcg	02/21/2013

NOTES: UNLESS OTHERWISE SPECIFIED

1. DIMENSIONS SHOWN ARE INCHES [MILIMETERS].
2. MATERAIL: ALUMINUM 6005-T5.  
FINISH: CLEAR ANODIZED 15  $\mu$ m THICK.
3. THE UNSPECIFIED DIMENSIONS ARE SPECIFIED BY 2D CAD FILE.

2X 1/4 BOLT SLOT

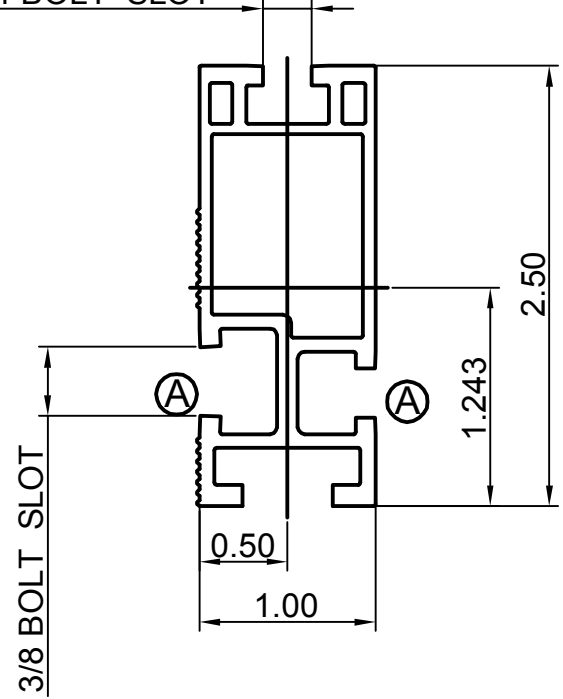

### Section properties:

Weight: 0.850 lbs/ft  
 Area: 0.723 in<sup>2</sup>  
 Perimeter: 17.325 in  
 Bounding Box: X: -0.500,0.500  
 Y: -1.243,1.257

Centroid:(0.000,0.000)  
 Moments of Incertia(in<sup>4</sup>): Ix=0.486,Iy=0.095  
 Section modulus in bending(in<sup>3</sup>): Wx=0.387,Wy=0.190  
 Radii of Gyration: X: 0.820, Y: 0.363

MATERIAL		SEE NOTES
Third Angle Projection:		
GENERAL SPECIFICATIONS		
All Dimensions in inches [millimeters]		
Tolerances		
X,XXX ± 0.01 [0.25mm]	Break all sharp edges	
X,XX ± 0.02 [0.50mm]	.010-.020 unless	
X,X ± 0.039 [1.0mm]	otherwise specified.	
Unless otherwise spec'd		
DRAWN BY	DATE	
zcg	02/21/2013	
CHECKED BY		
APPROVALS		

<b>Sunmodo Corp.</b>	
1905 E 5TH STREET, SUITE A, VANCOUVER, WA 98661	
TITLE HELIO STANDARD RAIL	
DRAWING NUMBER	A20144
SCALE:	NONE
SHEET	1 of 1

NOTES: UNLESS OTHERWISE SPECIFIED

1. DIMENSIONS SHOWN ARE INCHES [MILIMETERS].
2. MATERIAL: 6005-T5.  
FINISH: CLEAR ANODIZED 10um THICK.
3. THE UNSPECIFIED RADII ARE .02" MAX.
4. THE UNSPECIFIED DIMENSIONS ARE SPECIFIED BY 2D CAD FILE.

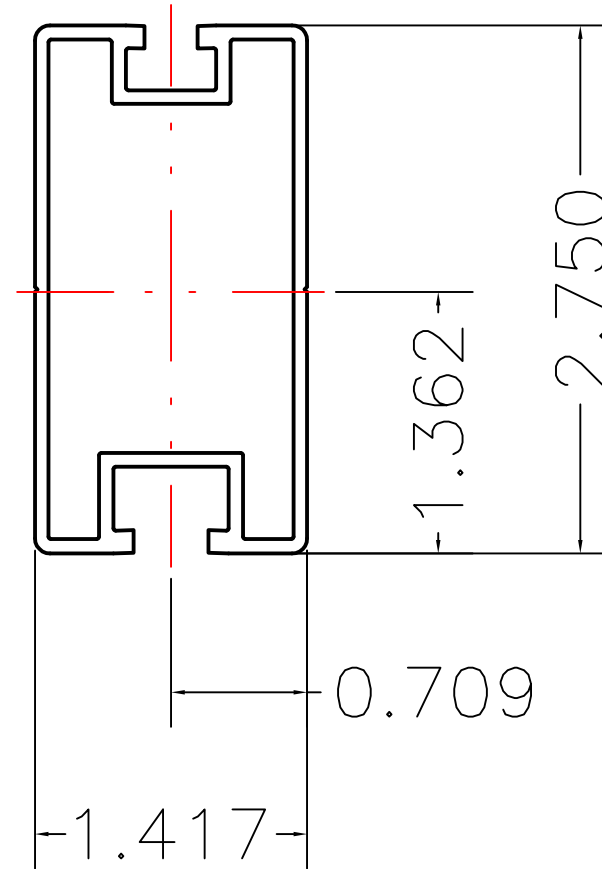

### Section properties:

Weight: 0.862 lbs/ft  
 Area: 0.736 in<sup>2</sup>  
 Perimeter: 19.824 in  
 Bounding Box: X: -0.709,0.709  
                   Y: -1.362,1.388  
 Centroid:(0.000,0.000)  
 Moments of Inertia(in<sup>4</sup>): I<sub>x</sub>=0.727,I<sub>y</sub>=0.214  
 Section modulus in bending(in<sup>3</sup>): W<sub>x</sub>=0.524,W<sub>y</sub>=0.302  
 Radii of Gyration: X: 994, Y: 0.539

THIS DRAWING IS CONFIDENTIAL PROPERTY OF SUNMODO AND ITS CONTENTS MAY NOT BE DISCLOSED WITHOUT THE PRIOR WRITTEN CONSENT OF SUNMODO CORP.

MATERIAL SEE NOTES	
Third Angle Projection:	
GENERAL SPECIFICATIONS All Dimensions in inches [millimeters]	
Tolerances	
X.XXX ±0.01 [0.25mm]	Break all sharp edges .010-.020 unless otherwise specified.
X.XX ±0.02 [0.50mm]	
X.X ±0.039 [1.0mm]	
Unless otherwise spec'd	
DRAWN BY KYY	DATE 01/18/2018
CHECKED BY	
APPROVALS	

<b>SunModo Corp.</b>	
14800 NE 65TH STREET, VANCOUVER WA 98682	
TITLE RAIL, HR300 (SUNRAY), EXTRUSION	
B	DRAWING NUMBER A20288
SCALE: NONE	SHEET 1 of 1

REV	DESCRIPTON	BY	DATE
A	0.44 WAS 0.41, 0.44 WAS 0.33	LWF	11/30/2015

NOTES: UNLESS OTHERWISE SPECIFIED

- 1. DIMENSIONS SHOWN ARE INCHES [MILIMETERS].
- 2. MATERIAL: ALUMINUM 6005-T5.  
FINISH: CLEAR ANODIZED 15 μm THICK.
- 3. THE UNSPECIFIED DIMENSIONS ARE SPECIFIED BY 2D CAD FILE.

2X 1/4 BOLT SLOT

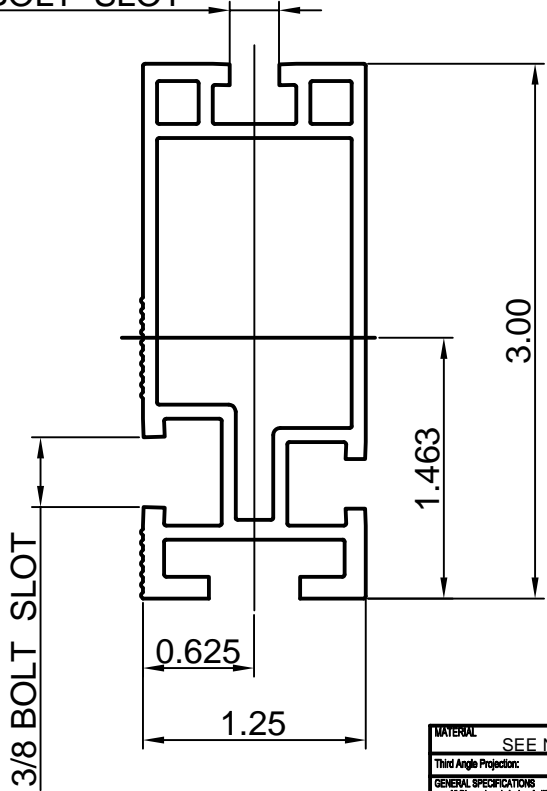

**Section properties:**

Weight: 1.151 lbs/ft  
 Area: 0.980 in<sup>2</sup>  
 Perimeter: 22.104 in  
 Bounding Box: X: -0.625,0.625  
                   Y: -1.463,1.537  
 Centroid:(0.000,0.000)  
 Moments of Inertia(in<sup>4</sup>): Ix=1.047,Iy=0.207  
 Section modulus in bending(in<sup>3</sup>): Wx=0.681,Wy=0.331  
 Radii of Gyration: X: 1.034, Y: 0.460

MATERIAL		SEE NOTES	
Third Angle Projection			
GENERAL SPECIFICATIONS			
All Dimensions in Inches [millimeters]			
Tolerances			
XXX ±0.01 (0.25mm)			
XX ±0.02 (0.50mm)			
X ±0.03 (1.0mm)			
Unless otherwise specified.			
DRAWN BY		DATE	
ZCJ		02/21/2013	
CHECKED BY		DATE	
APPROVALS		DATE	
		Break all sharp edges 0.10-0.25 unless otherwise specified.	
		TITLE	
		HELIO HEAVY RAIL	
		DRAWING NUMBER	
		A20145	
		SCALE: NONE	
		SHEET 1 of 1	

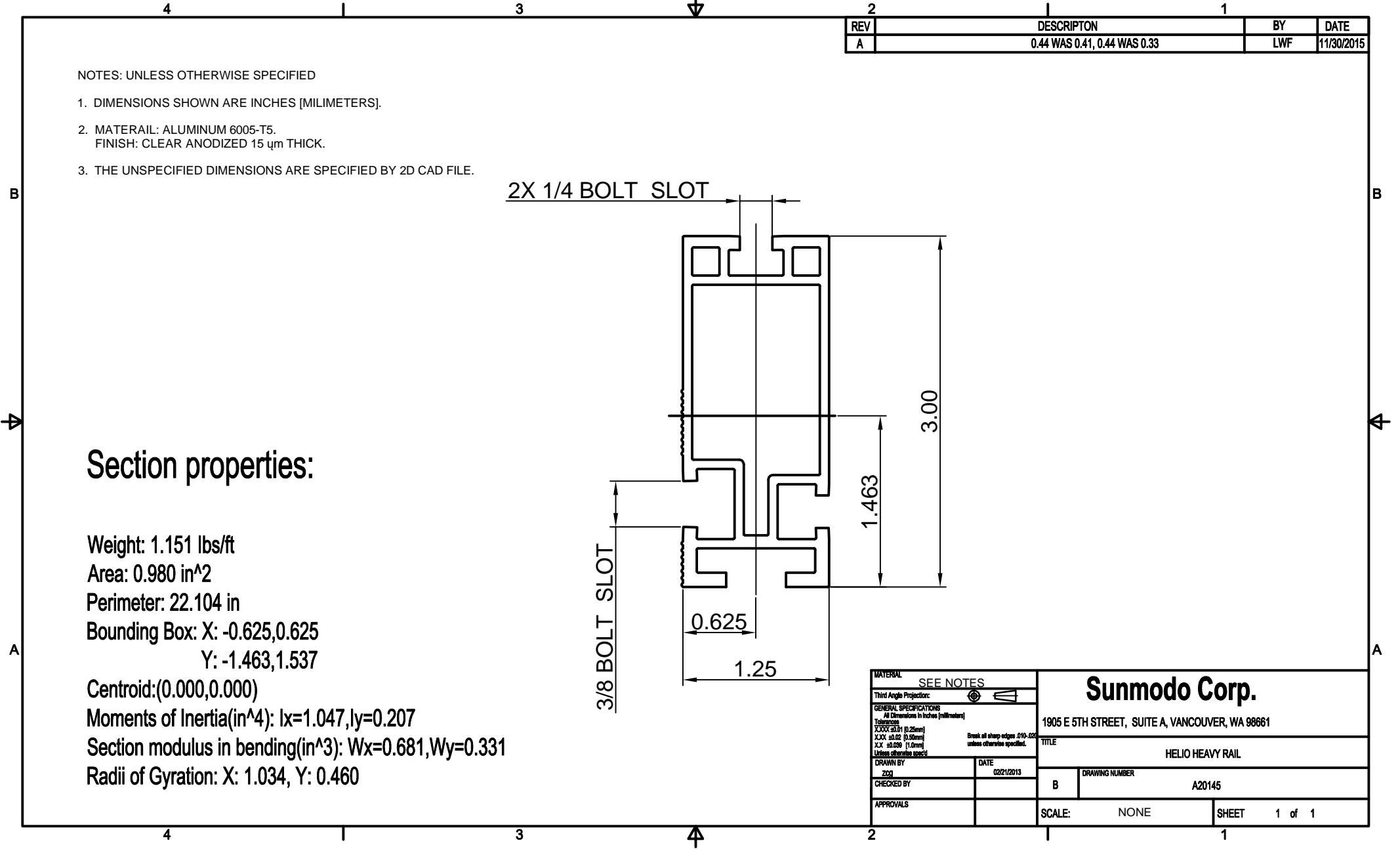

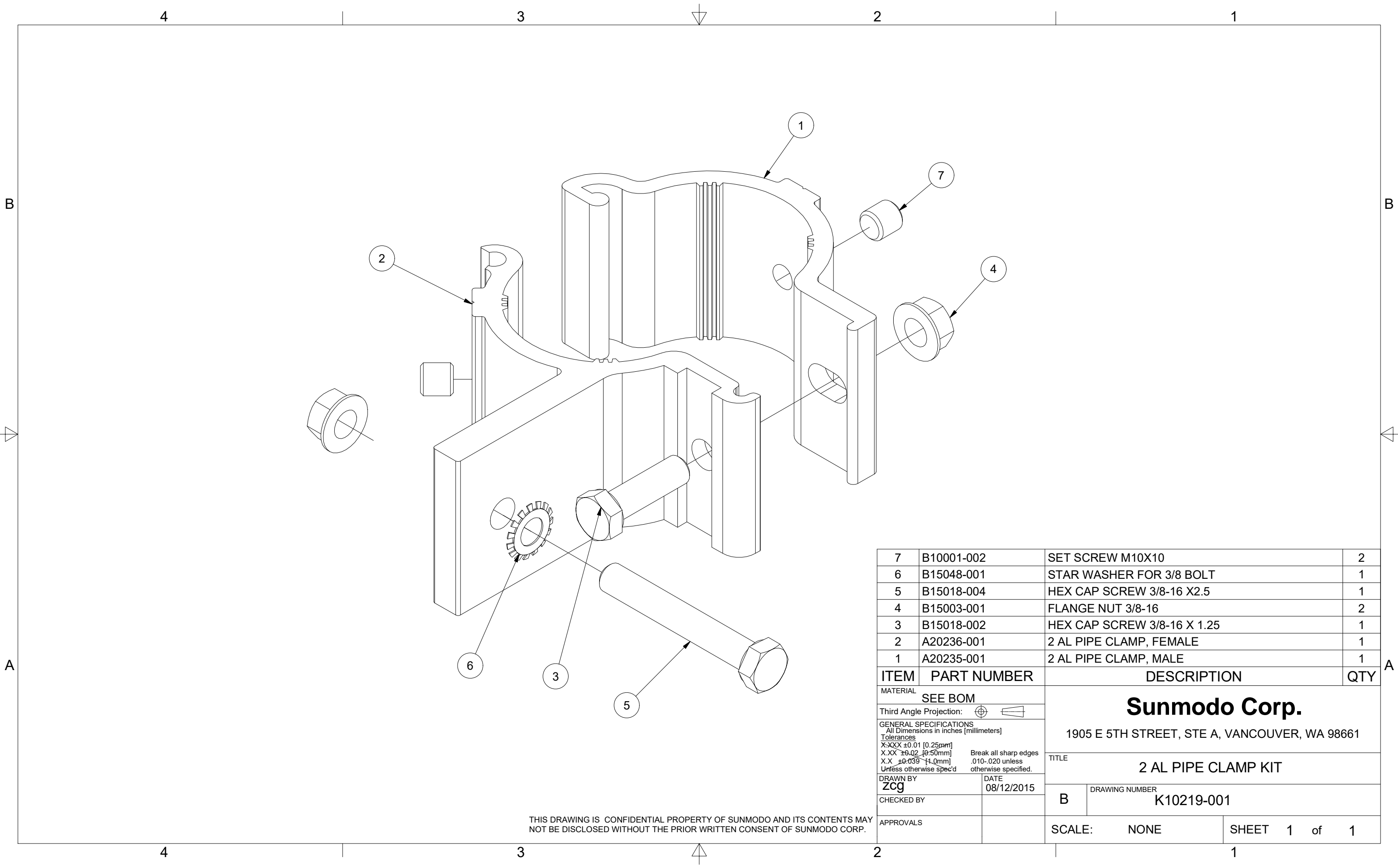

7	B10001-002	SET SCREW M10X10	2
6	B15048-001	STAR WASHER FOR 3/8 BOLT	1
5	B15018-004	HEX CAP SCREW 3/8-16 X2.5	1
4	B15003-001	FLANGE NUT 3/8-16	2
3	B15018-002	HEX CAP SCREW 3/8-16 X 1.25	1
2	A20236-001	2 AL PIPE CLAMP, FEMALE	1
1	A20235-001	2 AL PIPE CLAMP, MALE	1

ITEM	PART NUMBER	DESCRIPTION	QTY
MATERIAL		SEE BOM	
Third Angle Projection:			
GENERAL SPECIFICATIONS		All Dimensions in inches (millimeters)	
Tolerances		X-XXX ±0.01 [0.25mm]	
		X.XX ±0.02 [0.50mm]	
		X.X ±0.039 [1.0mm]	
		Unless otherwise spec'd	
DRAWN BY		DATE	
zcg		08/12/2015	
CHECKED BY			
APPROVALS			
TITLE		2 AL PIPE CLAMP KIT	
DRAWING NUMBER		K10219-001	
SCALE:		NONE	SHEET 1 of 1

THIS DRAWING IS CONFIDENTIAL PROPERTY OF SUNMODO AND ITS CONTENTS MAY NOT BE DISCLOSED WITHOUT THE PRIOR WRITTEN CONSENT OF SUNMODO CORP.

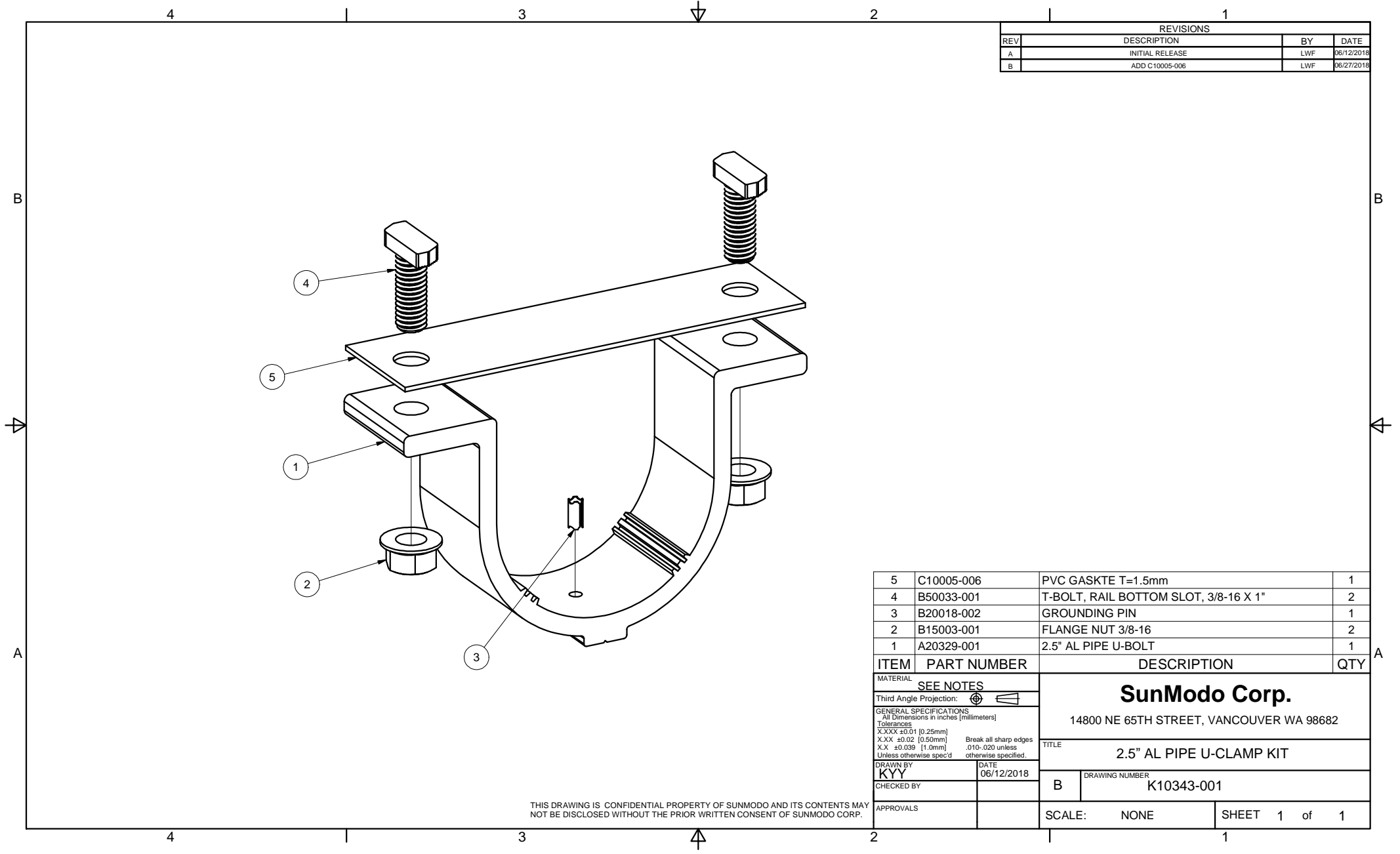

REVISIONS			
REV	DESCRIPTION	BY	DATE
A	INITIAL RELEASE	LWF	06/12/2018
B	ADD C10005-006	LWF	06/27/2018

ITEM	PART NUMBER	DESCRIPTION	QTY
5	C10005-006	PVC GASKTE T=1.5mm	1
4	B50033-001	T-BOLT, RAIL BOTTOM SLOT, 3/8-16 X 1"	2
3	B20018-002	GROUNDING PIN	1
2	B15003-001	FLANGE NUT 3/8-16	2
1	A20329-001	2.5" AL PIPE U-BOLT	1

MATERIAL		SEE NOTES	
Third Angle Projection:			
<b>SunModo Corp.</b> 14800 NE 65TH STREET, VANCOUVER WA 98682			
GENERAL SPECIFICATIONS		TITLE	
All Dimensions in inches [millimeters] Tolerances X.XXX ±0.01 [0.25mm] X.XX ±0.02 [0.50mm] X.X ±0.039 [1.0mm] Unless otherwise spec'd		2.5" AL PIPE U-CLAMP KIT	
DRAWN BY	DATE	DRAWING NUMBER	
KYY	06/12/2018	B K10343-001	
CHECKED BY		SCALE: NONE SHEET 1 of 1	
APPROVALS			

THIS DRAWING IS CONFIDENTIAL PROPERTY OF SUNMODO AND ITS CONTENTS MAY NOT BE DISCLOSED WITHOUT THE PRIOR WRITTEN CONSENT OF SUNMODO CORP.



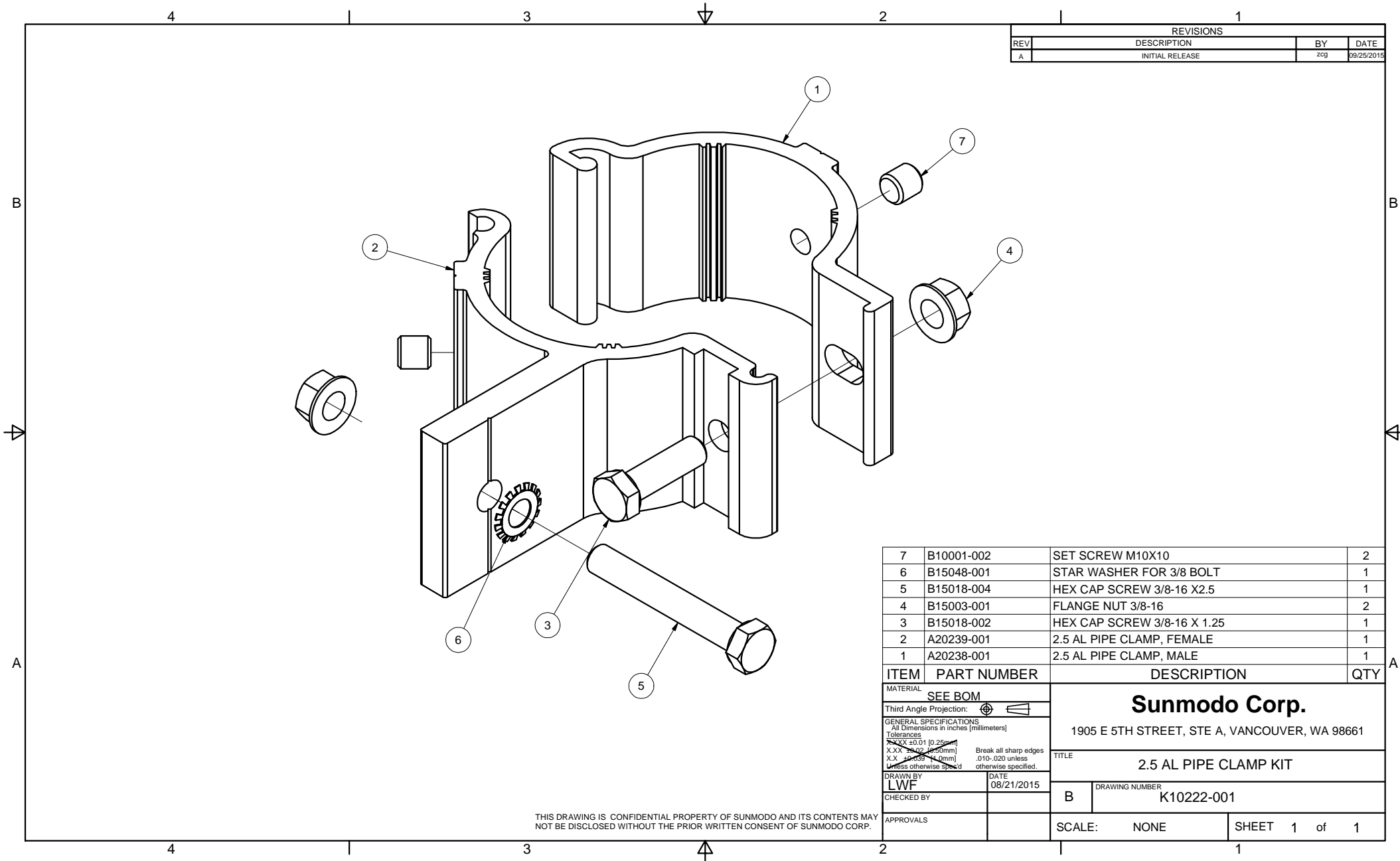

REVISIONS			
REV	DESCRIPTION	BY	DATE
A	INITIAL RELEASE	zcg	09/25/2015

ITEM	PART NUMBER	DESCRIPTION	QTY
7	B10001-002	SET SCREW M10X10	2
6	B15048-001	STAR WASHER FOR 3/8 BOLT	1
5	B15018-004	HEX CAP SCREW 3/8-16 X2.5	1
4	B15003-001	FLANGE NUT 3/8-16	2
3	B15018-002	HEX CAP SCREW 3/8-16 X 1.25	1
2	A20239-001	2.5 AL PIPE CLAMP, FEMALE	1
1	A20238-001	2.5 AL PIPE CLAMP, MALE	1

ITEM	PART NUMBER	DESCRIPTION	QTY
MATERIAL		SEE BOM	
Third Angle Projection:			
GENERAL SPECIFICATIONS		Sunmodo Corp. 1905 E 5TH STREET, STE A, VANCOUVER, WA 98661	
All Dimensions in inches [millimeters]		TITLE	
Tolerances		2.5 AL PIPE CLAMP KIT	
X.XX ±0.01 (0.25mm)		DRAWING NUMBER	
X.XX ±0.02 (0.51mm)		B K10222-001	
X.X ±0.03 (0.76mm)		SCALE: NONE	
Unless otherwise specified		SHEET 1 of 1	
DRAWN BY		DATE	
LWF		08/21/2015	
CHECKED BY		APPROVALS	

THIS DRAWING IS CONFIDENTIAL PROPERTY OF SUNMODO AND ITS CONTENTS MAY NOT BE DISCLOSED WITHOUT THE PRIOR WRITTEN CONSENT OF SUNMODO CORP.

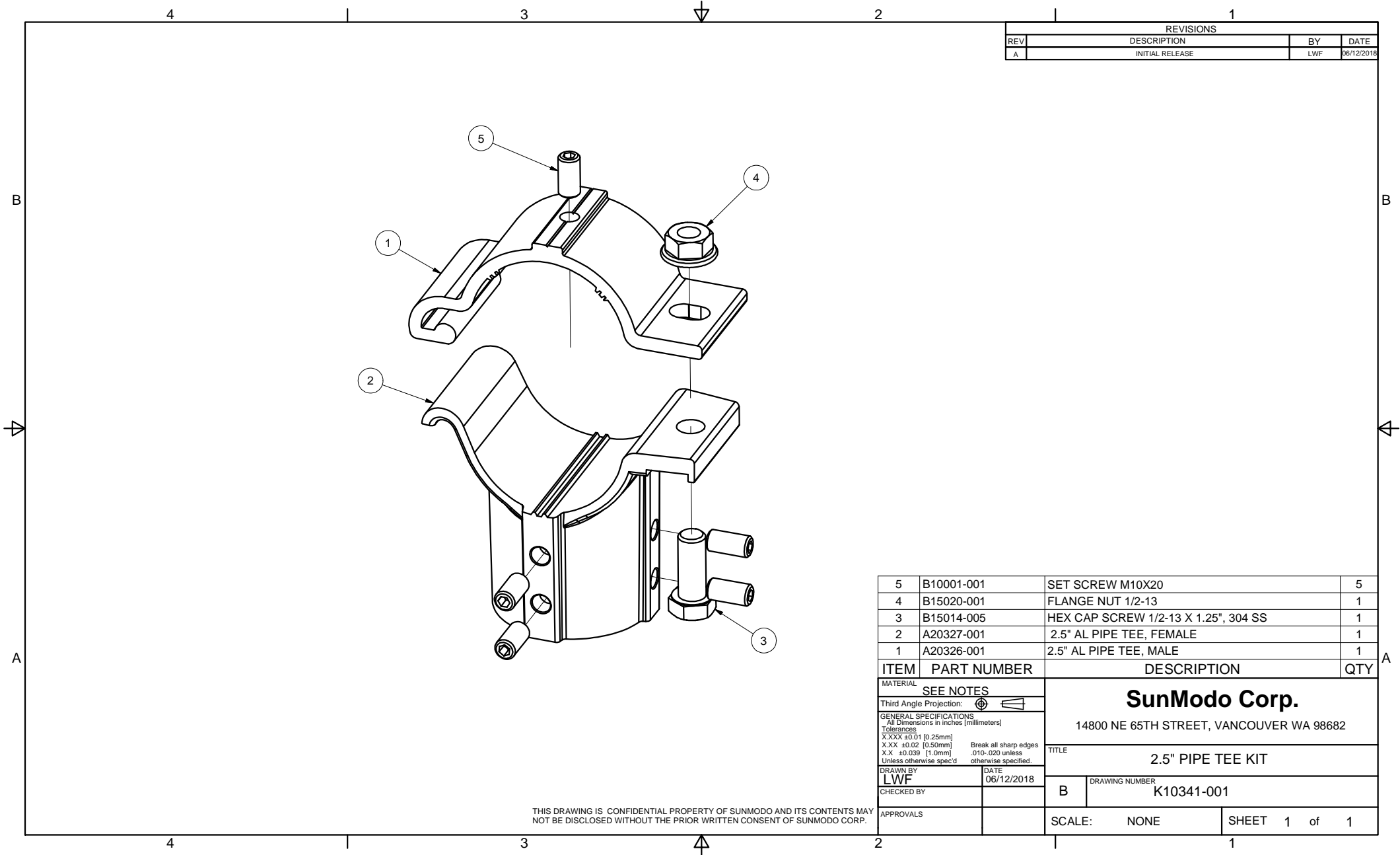

REVISIONS			
REV	DESCRIPTION	BY	DATE
A	INITIAL RELEASE	LWF	06/12/2018

ITEM	PART NUMBER	DESCRIPTION	QTY
5	B10001-001	SET SCREW M10X20	5
4	B15020-001	FLANGE NUT 1/2-13	1
3	B15014-005	HEX CAP SCREW 1/2-13 X 1.25", 304 SS	1
2	A20327-001	2.5" AL PIPE TEE, FEMALE	1
1	A20326-001	2.5" AL PIPE TEE, MALE	1

MATERIAL		SEE NOTES	
Third Angle Projection:			
GENERAL SPECIFICATIONS		<b>SunModo Corp.</b> 14800 NE 65TH STREET, VANCOUVER WA 98682	
Tolerances		TITLE	
X.XXX ±0.01 [0.25mm] X.XX ±0.02 [0.50mm] X.X ±0.039 [1.0mm] Unless otherwise spec'd		2.5" PIPE TEE KIT	
DRAWN BY		DATE	
LWF		06/12/2018	
CHECKED BY		DRAWING NUMBER	
		B K10341-001	
APPROVALS		SCALE: NONE SHEET 1 of 1	

THIS DRAWING IS CONFIDENTIAL PROPERTY OF SUNMODO AND ITS CONTENTS MAY NOT BE DISCLOSED WITHOUT THE PRIOR WRITTEN CONSENT OF SUNMODO CORP.

REVISIONS			
REV	DESCRIPTION	BY	DATE
A	INITIAL RELEASE	LWF	06/12/2018

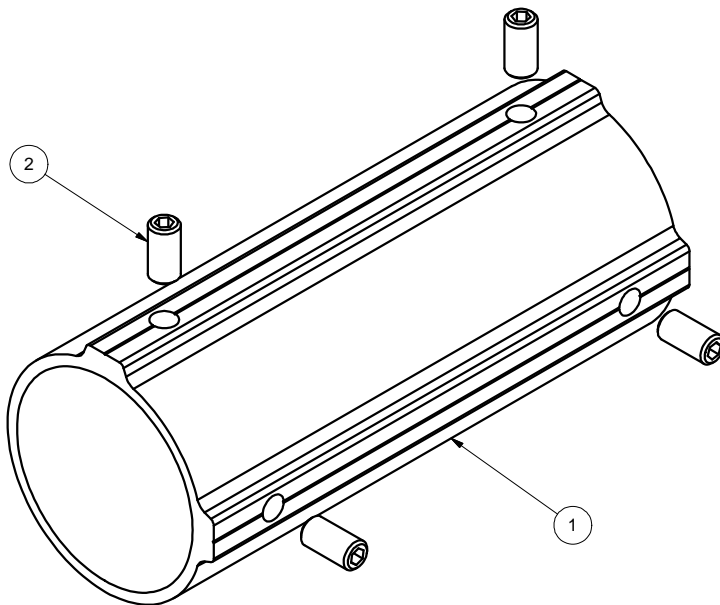

2	B10001-001	SET SCREW M10X20	4
1	A20328-001	2.5" PIPE SPLICE	1
ITEM	PART NUMBER	DESCRIPTION	QTY
MATERIAL		SEE NOTES	
Third Angle Projection:			
GENERAL SPECIFICATIONS		<b>SunModo Corp.</b> 14800 NE 65TH STREET, VANCOUVER WA 98682	
All Dimensions in inches [millimeters] Tolerances X.XXX ±0.01 [0.25mm] X.XX ±0.02 [0.50mm] X.X ±0.039 [1.0mm] Unless otherwise spec'd		TITLE <b>2.5" PIPE SPLICE KIT</b>	
DRAWN BY	DATE	DRAWING NUMBER	
LWF	06/12/2018	B K10342-001	
CHECKED BY			
APPROVALS		SCALE: NONE	SHEET 1 of 1

THIS DRAWING IS CONFIDENTIAL PROPERTY OF SUNMODO AND ITS CONTENTS MAY NOT BE DISCLOSED WITHOUT THE PRIOR WRITTEN CONSENT OF SUNMODO CORP.

NOTES: UNLESS OTHERWISE SPECIFIED

1. DIMENSIONS SHOWN ARE INCHES [MILIMETERS].
2. MATERIAL:HIGH STRENGTH STEEL PIPE OR TUBE.
3. FINISH: HOT DIP GALVANIZE PER ASTM A123 / A123M - 02.

MINIMUM 50 KSI YIELD STRESS.

4. BREAK ALL BURRS AND SHARP EDGES.

5. ALL WELDING MUST BE IN COMPLIANCE WITH AWS CODE D1;1.

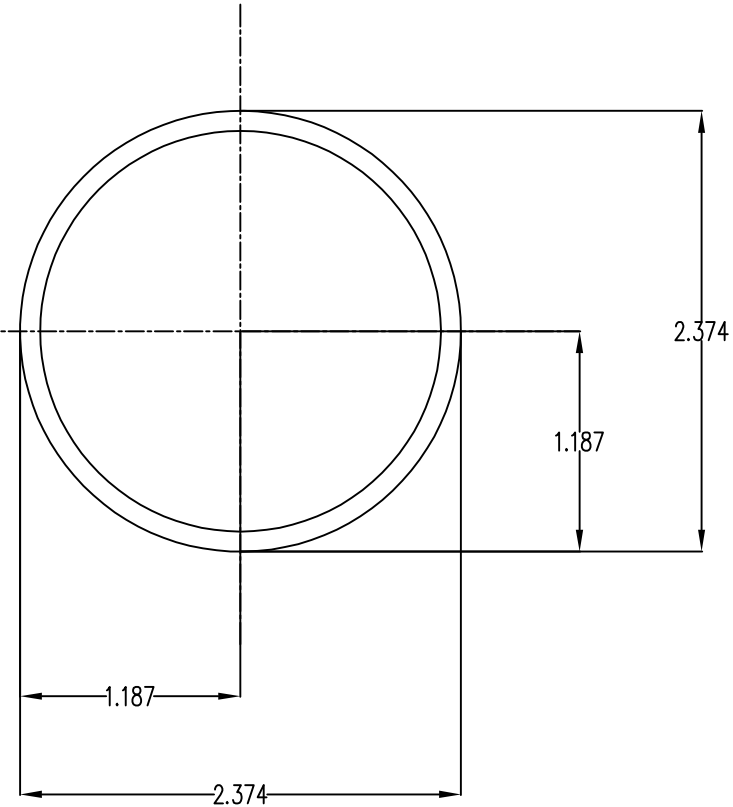

## Section properties:

Weight: 2.641 lbs/ft

Area: 0.776 in<sup>2</sup>

Perimeter: 14.238 in

Bounding Box: X: -1.187,1.187

Y: -1.187,1.187

Centroid:(0.000,0.000)

Moments of Inertia(in<sup>4</sup>): Ix=0.499,Iy=0.499

Section modulus in bending(in<sup>3</sup>): Wx=0.420,Wy=0.420

Radii of Gyration: X: 0.802, Y: 0.802

MATERIAL		SEE NOTES		<b>Sunmodo Corp.</b> 14800 NE 85TH STREET, VANCOUVER WA 98682	
Third Angle Projection:					
GENERAL SPECIFICATIONS				TITLE	
All Dimensions in Inches (millimeters)				PIPE, HSS, 2.375" OD X 12 GAUGE,L=XXX	
Tolerances				Break all sharp edges .010-.020 unless otherwise specified.	
XXX ±0.01 (0.25mm)					
XX ±0.02 (0.50mm)					
X ±0.050 (1.27mm)					
Unless otherwise specified					
DRAWN BY	DATE	B		DRAWING NUMBER	
LWF	04/03/2019			A21165	
CHECKED BY					
APPROVALS				SCALE: NONE SHEET 1 of 1	

NOTES: UNLESS OTHERWISE SPECIFIED

1. DIMENSIONS SHOWN ARE INCHES [MILIMETERS].
2. MATERAIL:HIGH STRENGTH STEEL PIPE OR TUBE.
3. FINISH: HOT DIP GALVANIZE PER ASTM A123 / A123M - 02.

MINIMUM 50 KSI YIELD STRESS.

4. BREAK ALL BURRS AND SHARP EDGES.
5. ALL WELDING MUST BE IN COMPLIANCE WITH AWS CODE D1;1.

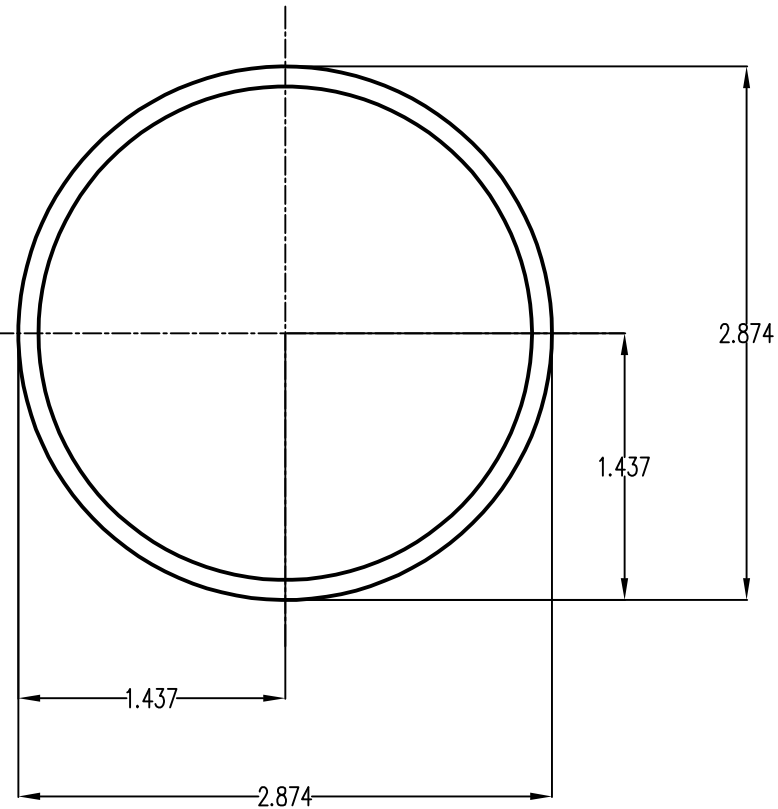

### Section properties:

Weight: 3.201 lbs/ft

Area: 0.941 in<sup>2</sup>

Perimeter: 17.378 in

Bounding Box: X: -1.437,1.437

Y: -1.437,1.437

Centroid:(0.000,0.000)

Moments of Inertia(in<sup>4</sup>): Ix=0.901,Iy=0.901

Section modulus in bending(in<sup>3</sup>): Wx=0.627,Wy=0.627

Radii of Gyration: X: 0.979, Y: 0.979

MATERIAL		SEE NOTES		<b>Sunmodo Corp.</b> 14800 NE 85TH STREET, VANCOUVER WA 98682	
Third Angle Projection:					
GENERAL SPECIFICATIONS All Dimensions in Inches (millimeters)				TITLE	
Tolerances XXX ±0.01 (0.25mm) XX ±0.02 (0.50mm) X ±0.030 (1.0mm) Unless otherwise specified				PIPE, HSS, 2.875" OD X 12 GAUGE,L=XXX	
DRAWN BY LWF		DATE 04/03/2019		DRAWING NUMBER A21168	
CHECKED BY				B	
APPROVALS				SCALE: NONE SHEET 1 of 1	