



Project Number: U2716-114-201

October 22, 2020

Sunmodo
14800 NE 65th Street
Vancouver, WA 98682

**REFERENCE: Sunmodo Sunturf Ground Mount A5
Ground Mount PV Array Installation**

To Whom It May Concern:

Per request of Sunmodo, we have been asked to prepare the structural design of a ground-mounted PV solar array system with several foundation options as shown in the attached calculations. The adopted building code in this jurisdiction is the Florida Building Code 2020 Edition (2018 IBC). Vector Structural Engineering requires that we review each site specific install, and we are not liable for installs at site specific locations we have not reviewed. The following design parameters are used in our analysis:

- Minimum Design Loads for Buildings and Other Structures (ASCE 7-16)
- Design wind speed for risk category I structures: 140 mph
- Wind exposure: B
- Ground snow load: 70 psf
- The ground screws and helical piers must be tested to 1.5 times uplift and 2.0 times lateral reactions found in the table below. A minimum of one ground screw or helical pier must be tested.

Load (ASD)	Value (lbs)	Factor of Safety	Test Value (lbs)
UPLIFT	2320	1.5	3480
LATERAL	1690	2	3380

Foundation concrete shall have a minimum compressive strength of 2500 psi at 28 days. Cement for all concrete shall be Type I or II with a minimum of 6% entrained air with a water/cement ratio of 0.50. Maximum aggregate size shall be 3/4". No special inspection of concrete strength is required.

Footings are designed based on an allowable soil bearing pressure of 1500 psf an allowable skin friction of 250 psf, an allowable lateral bearing pressure of 150 pcf, and a coefficient of friction of 0.3. Vector Structural Engineering strongly recommends independent soils testing be performed by a licensed geotechnical engineer to verify the assumed soil parameters.

All ground mounts are to be installed per manufacturer’s recommendations. The use of solar panel support span tables provided by the manufacturer is allowed only where the site conditions and solar panel configuration match the description of the span tables. Electrical engineering is beyond our scope. All work performed must be in accordance with accepted industry-wide methods and applicable safety standards. Vector Structural Engineering assumes no responsibility for improper installation of the solar panels.

Very truly yours,

VECTOR STRUCTURAL ENGINEERING, LLC
FL Firm License: COA 26626

Jacob Proctor, P.E.
FL License: 74277
Project Engineer

Enclosures

JSP/stb

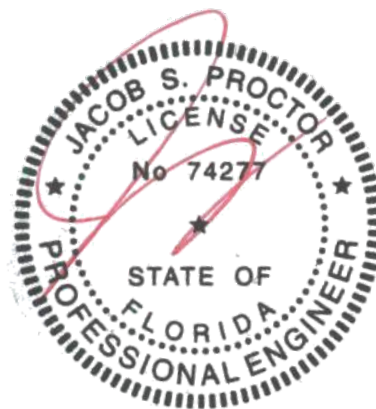

10/22/2020



JOB NO. U2716-114-191
 PROJECT SUNMODO SUNTURF GROUND MOUNTS A5
 SUBJECT ALL OPTIONS

651 W GALENA PARK BLVD. #101 (801) 990-1775
 DRAPER, UTAH 84020 (801) 990-1776 FAX

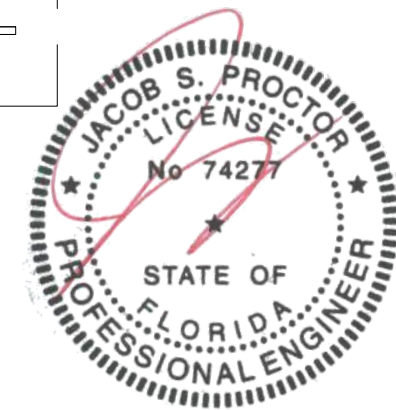
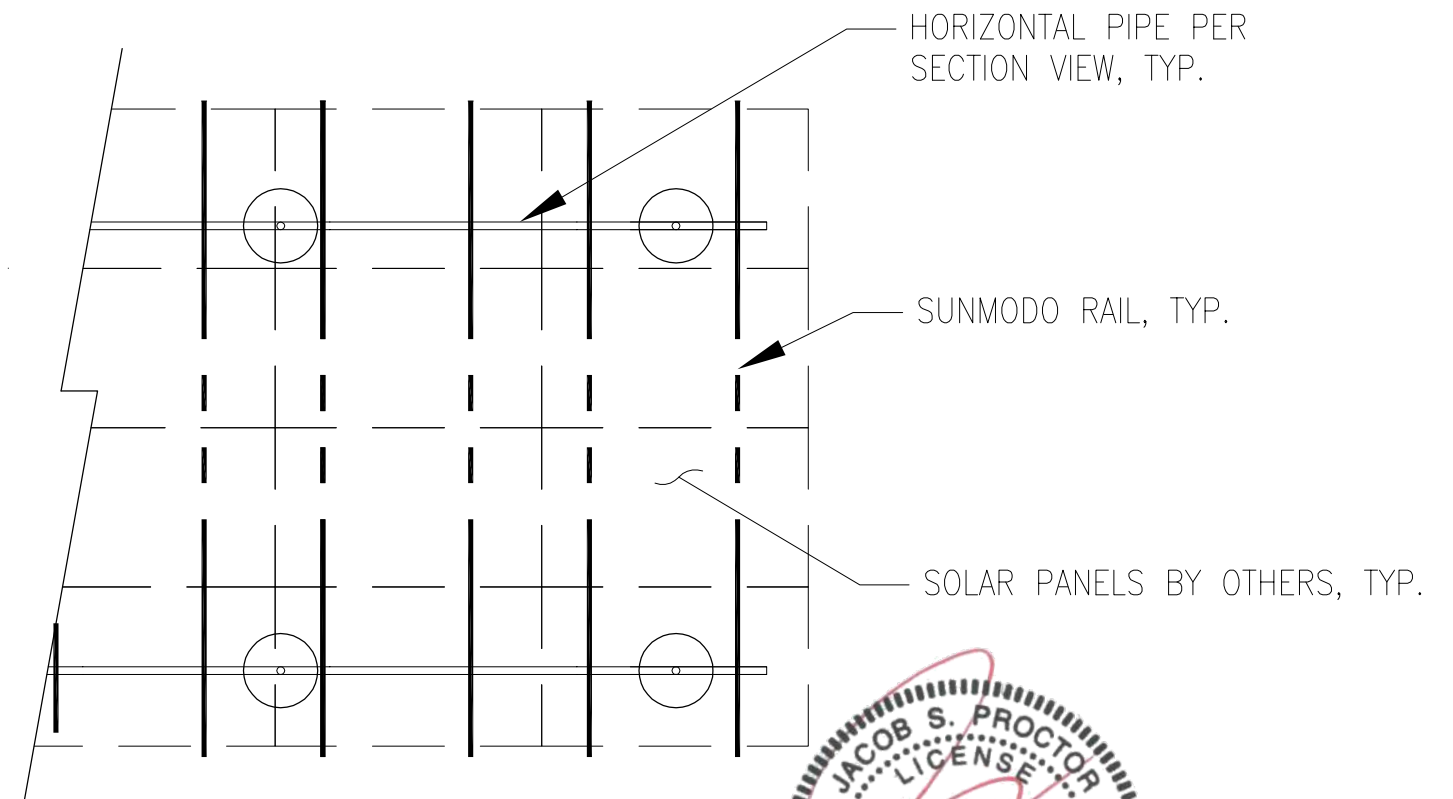
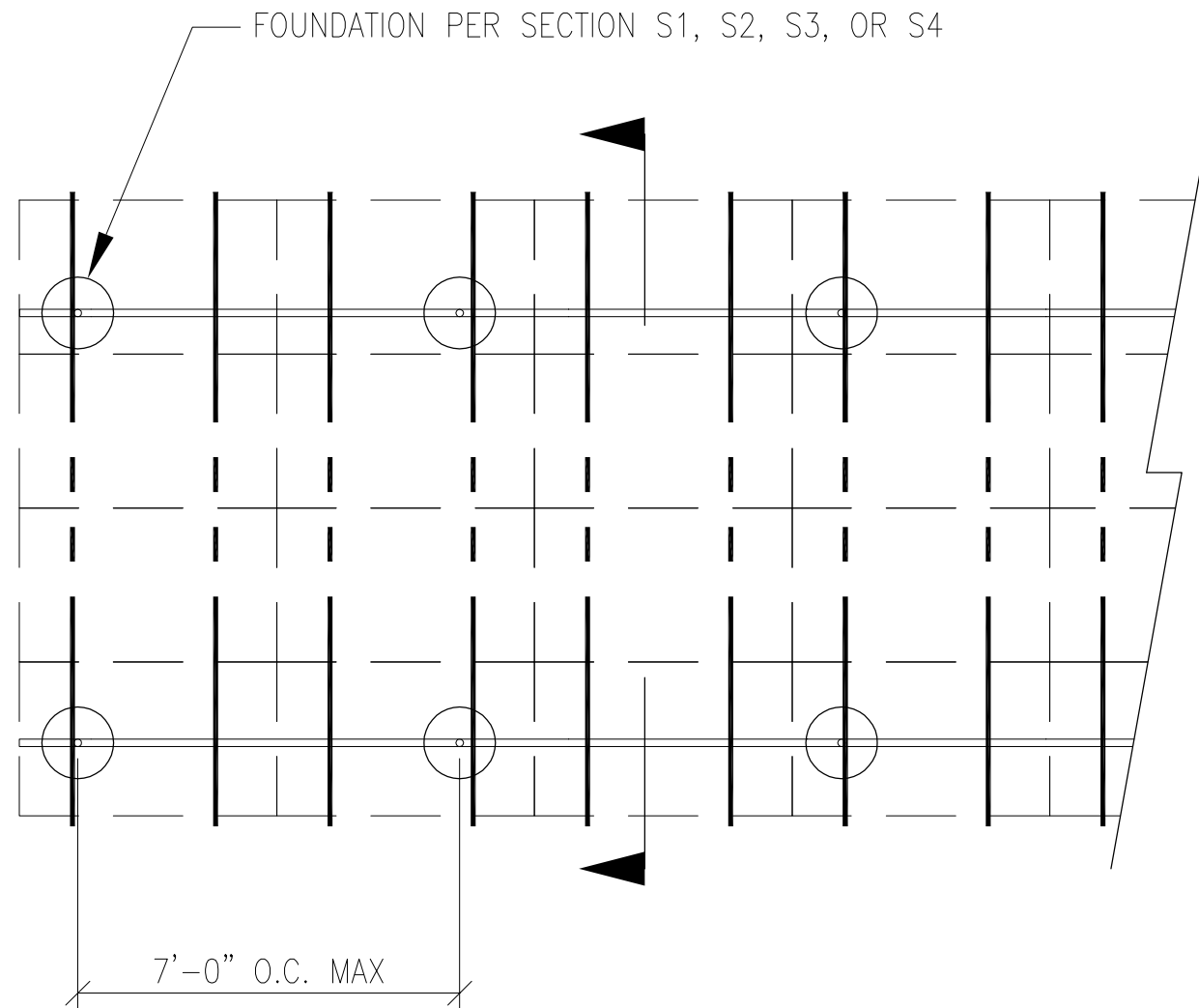

PV ARRAY PLAN

10/22/2020

P1

N.T.S.

Vector Engineers requires that we review each site specific install and is not liable for installs at site specific locations we have not reviewed.

PROJECT SUNMODO SUNTURF GROUND MOUNTS A5

SUBJECT DRILLED PIER OPTION

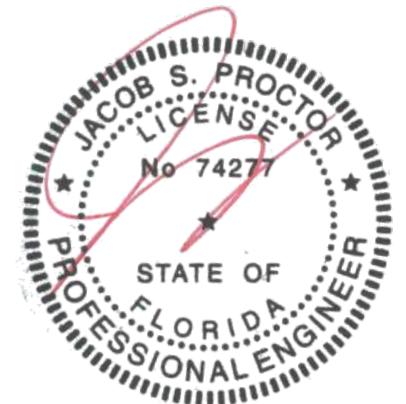
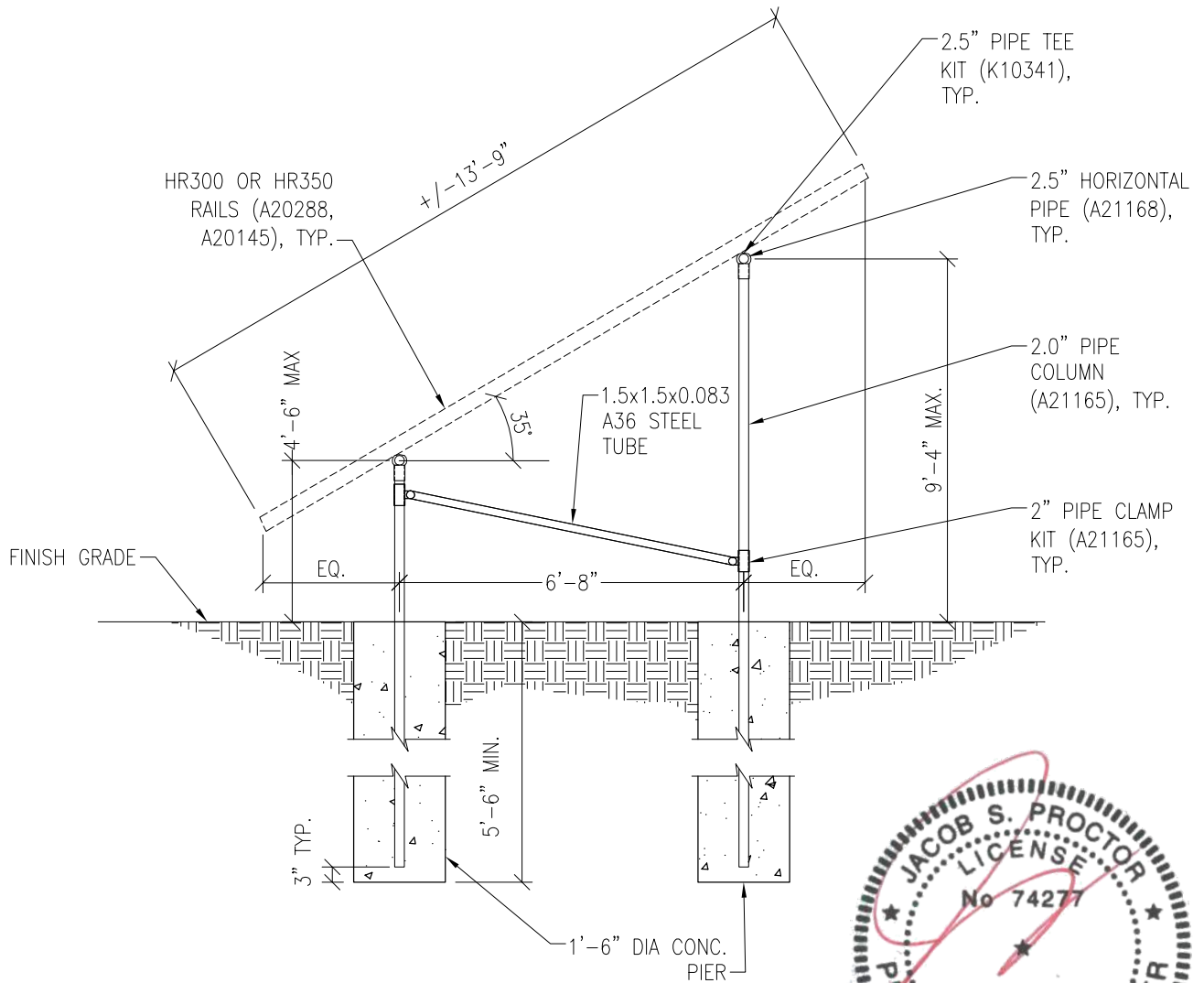

10/22/2020

Vector Engineers requires that we review each site specific install and is not liable for installs at site specific locations we have not reviewed.

PV ARRAY SECTION

N.T.S.

S1

PROJECT SUNMODO SUNTURF GROUND MOUNTS A5

SUBJECT HELICAL PIER OPTION

NOTES:

1. For ground mount components see Section S1.
2. A minimum of (1) helical pier must be load-tested as follows:
 - 2.1. Safety factor for uplift = 1.5,
 - 2.2. Safety factor for lateral loads = 2.0
 - 2.3. Upward deflection limit = 1/2"
 - 2.4. Lateral deflection limit = 1"
 - 2.5. The load tests must be performed by an approved contractor.

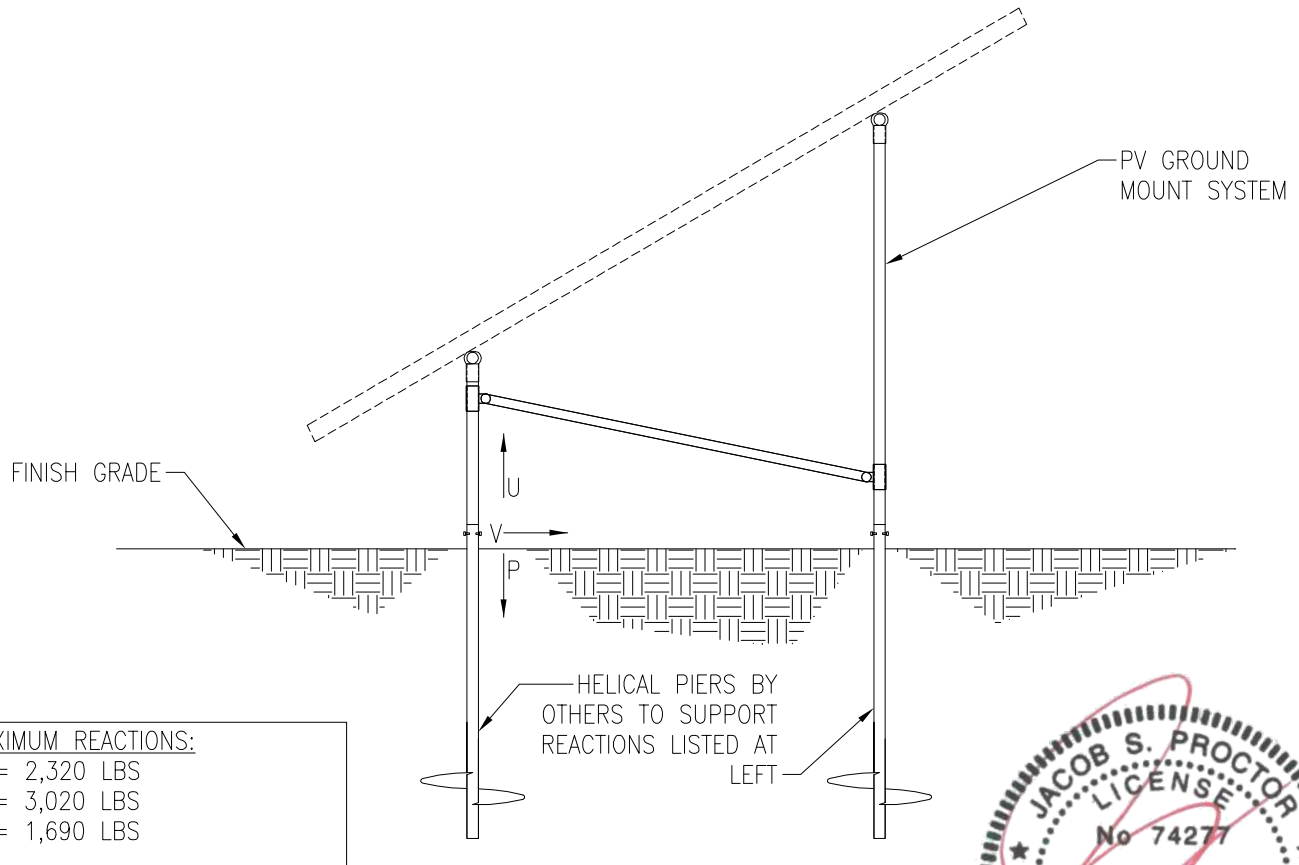

MAXIMUM REACTIONS:
 U = 2,320 LBS
 P = 3,020 LBS
 V = 1,690 LBS

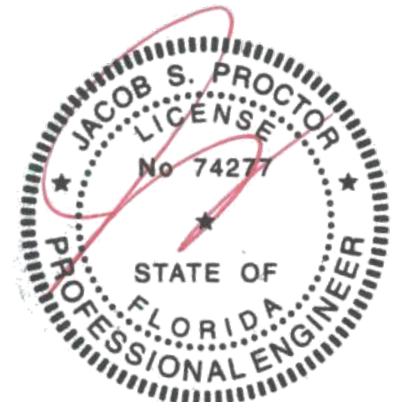

Vector Engineers requires that we review each site specific install and is not liable for installs at site specific locations we have not reviewed.

PV ARRAY SECTION

10/22/2020

N.T.S.

S2

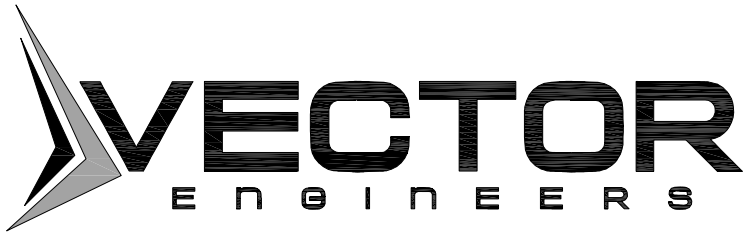

JOB NO. U2716-114-191

PROJECT SUNMODO SUNTURF GROUND MOUNTS A5

SUBJECT GROUND SCREW OPTION

NOTES:

- 1. For ground mount components see Section S1.
- 2. A minimum of (1) ground screw must be load-tested as follows:
 - 2.1. Safety factor for uplift = 1.5,
 - 2.2. Safety factor for lateral loads = 2.0
 - 2.3. Upward deflection limit = 1/2"
 - 2.4. Lateral deflection limit = 1"
 - 2.5. The load tests must be performed by an approved contractor.

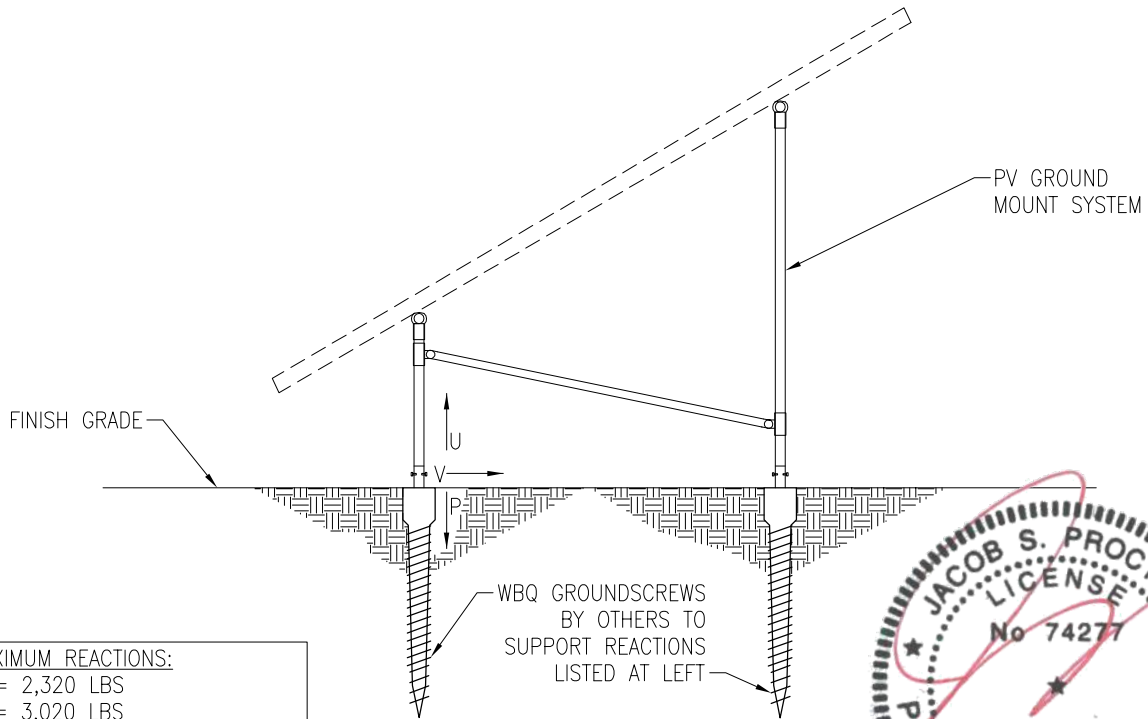

MAXIMUM REACTIONS:
 U = 2,320 LBS
 P = 3,020 LBS
 V = 1,690 LBS

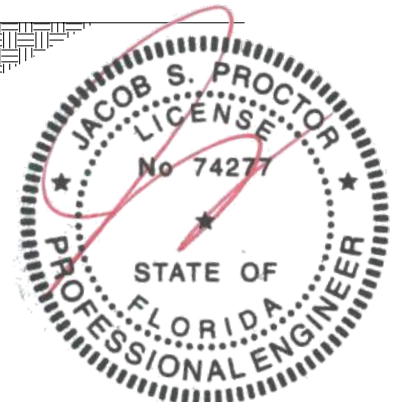

Vector Engineers requires that we review each site specific install and is not liable for installs at site specific locations we have not reviewed.

PV ARRAY SECTION

10/22/2020

N.T.S.

S3

651 W GALENA PARK BLVD. #101
DRAPER, UTAH 84020

(801) 990-1775
(801) 990-1776 FAX

WWW.VECTORSE.COM

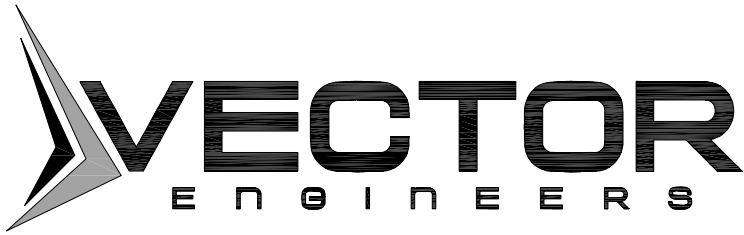

JOB NO. U2716-114-191

PROJECT SUNMODO SUNTURF GROUND MOUNTS A5

SUBJECT BALLASTED BLOCK OPTION

NOTES:

1. For ground mount components see Section S1.

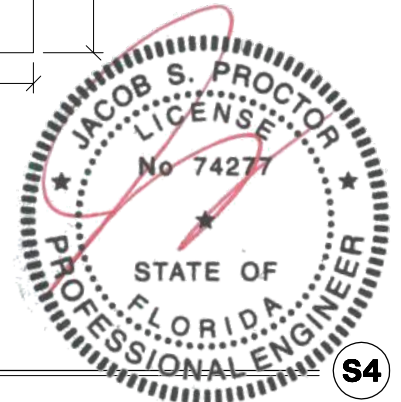
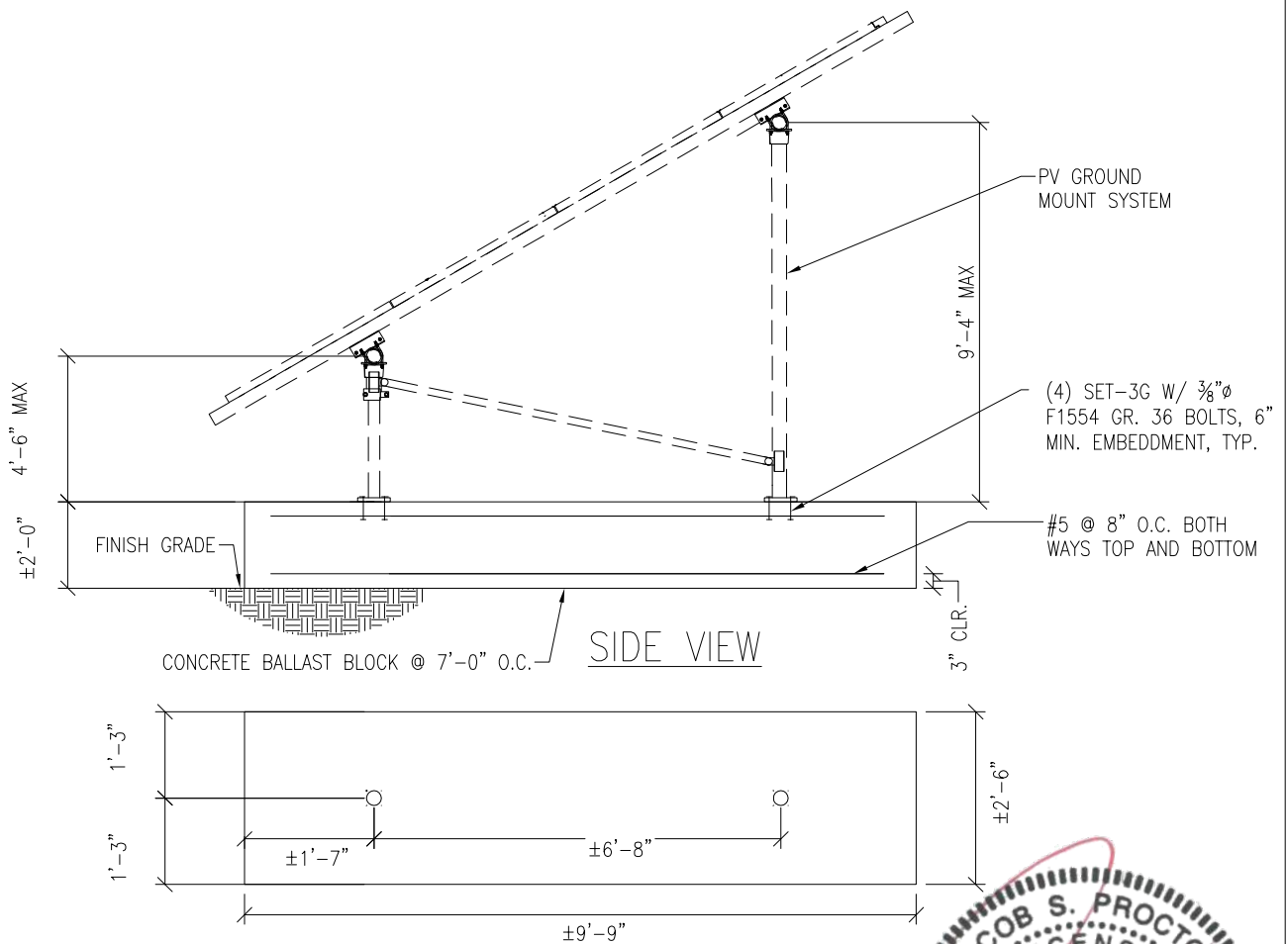

Vector Engineers requires that we review each site specific install and is not liable for installs at site specific locations we have not reviewed.

PV ARRAY SECTION

N.T.S.

651 W GALENA PARK BLVD. #101
DRAPER, UTAH 84020

(801) 990-1775
(801) 990-1776 FAX

10/22/2020

WWW.VECTORSE.COM

S4

PROJECT: A5 – Sunmodo Sunturf GM

SUBJECT: Dead Load

Design Weight:

Individual Panel Weight [lb]:	50.7
Panel Transverse Length (T5) [in]:	41.2
Panel Transverse Length (T5) [ft]:	3.4
Panel Longitudinal Length (L2) [in]:	81.4
Panel Longitudinal Length (L2) [ft]:	6.8
Individual Panel Area [ft ²]:	23.3
Individual Panel Weight [psf]:	2.2
# of Panels in Transverse Direction:	4
Approximate Transverse Length (T4) [ft]:	13.7
# of Panels in Longitudinal Direction:	12
Approximate Longitudinal Length (L1) [ft]:	81.4
Transverse Column Spacing (T1) [ft]:	6.7
Longitudinal Column Spacing (L3) [ft]:	7.0
# of Columns in Longitudinal Direction:	12
# of Columns in Transverse Direction:	2
Total Number of Columns:	24
Panel Slope from Horizontal (a) [°]:	35.0
Short Column Height (H1) [ft]:	4.5
Approximate Tall Column Height (H2) [ft]:	9.2
Transverse Brace between Columns :	Yes
Approximate Brace Length (B1) [ft]:	9.0
Weight of Columns [plf]:	3.7
Weight of Cross Pipe [plf]:	3.7
Weight of Brace [plf]:	3.7
Tributary Transverse Length per Column [ft]:	6.9
Tributary Longitudinal Length per Column [ft]:	7.0
Tributary Area per Column [ft ²]:	48.1
Rail Weight [plf]:	1.0
Transverse Rail Weight per Column [lb]:	27.5
Longitudinal Rail Weight per Column [lb]:	25.6
Tall Column Weight [lb]:	33.6
Panel Weight per Column [lb]:	104.6
Rail Weight per Column [lb]:	27.5
Cross Pipe Weight per Column [lb]:	25.6
Brace Weight per Column [lb]:	16.4
Total Weight per Column (1.0 D) [lb]:	207.7

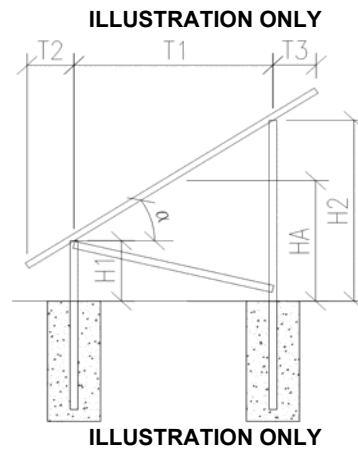
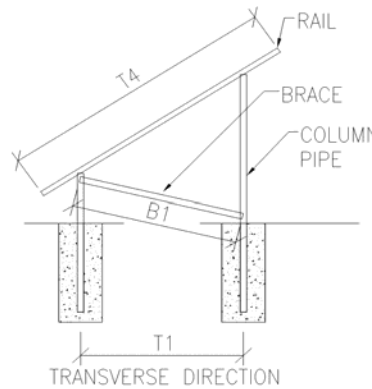

Assumptions:

- T2 = T3



JOB NO.: U2716-114-191

DESIGNED: STB

DATE: 08/01/19

PROJECT: A5 – Sunmodo Sunturf GM

SUBJECT: Snow Load

SNOW LOAD (S):

ASCE 7 Standard:	10	
Panel Slope from Horizontal [°]:	35.0	
Snow Ground Load, p_g [psf]:	70.0	(Section 7.2)
Terrain Category:	B	(Table 7-2)
Exposure of Roof:	Fully Exposed	(Table 7-2)
Exposure Factor, C_e :	0.9	(Table 7-2)
Thermal Factor, C_t :	1.2	(Table 7-3)
Risk Category:	I	(Table 1.5-1)
Importance Factor, I_s :	0.8	(Table 1.5-2)
Flat Roof Snow Load, p_f [psf]:	42	(Equation 7.3-1)
Minimum Roof Snow Load, p_m [psf]:	0	(Section 7.3.4)
Unobstructed Slippery Surface?	Yes	(Section 7.4)
Slope Factor Figure:	Figure 7-2c	(Section 7.4)
Roof Slope Factor, C_s :	0.636	(Figure 7-2)
Sloped Roof Snow Load, p_s [psf]:	27	(Equation 7.4-1)
Design Snow Load, S [psf]:	27	
Tributary Transverse Length [ft]:	5.6	
Tributary Longitudinal Length [ft]:	7	
Tributary Area per Column [ft ²]:	39.4	
Snow Load per Column (1.0 S) [lb]:	1060.8	



PROJECT: A5 – Sunmodo Sunturf GM

SUBJECT: Wind Pressure

Design Wind Load:

ASCE 7 Standard:	10	
Basic Wind Speed, V [mph]:	140	
Risk Category:	I	
Exposure Category	B	(Section 26.7.3)
Velocity Pressure Exposure Coefficient, K_h :	0.57	(Table 27.3-1)
Topographic Factor, K_{ht} :	1.0	(Section 26.8.2)
Wind Directionality Factor, K_d :	0.85	(Table 26.6-1)
Internal Pressure Coefficient, GC_{pi} :	0.00	(Table 26.11-1)
Velocity Pressure, q_h [psf]:	24.3	(Equation 27.3-1)
Gust Effect Factor, G:	0.85	(Section 26.9.1)
Panel Slope [degrees]:	35.0	

Net Pressure Coefficients (C_N) per: (Figure 27.4-4)

Clear Wind Flow	C_{NW}	C_{NL}
Case 1 ($\gamma = 0^\circ$, Load Case A)	-1.80	-1.80
Case 2 ($\gamma = 0^\circ$, Load Case B)	-2.43	-0.57
Case 3 ($\gamma = 180^\circ$, Load Case A)	2.10	2.17
Case 4 ($\gamma = 180^\circ$, Load Case B)	2.67	1.07

Design Wind Pressures (p) [psf] per: (Equation 27.4-3)

Clear Wind Flow	$q_h GC_{NW}$	$q_h GC_{NL}$
Case 1 ($\gamma = 0^\circ$, Load Case A)	-37.2	-37.2
Case 2 ($\gamma = 0^\circ$, Load Case B)	-50.3	-11.7
Case 3 ($\gamma = 180^\circ$, Load Case A)	43.4	44.8
Case 4 ($\gamma = 180^\circ$, Load Case B)	55.1	22.0

Wind Pressure on Each Side of Panels [psf]

Clear Wind Flow	Short Col. Pressure	Long Col. Pressure
Case 1 ($\gamma = 0^\circ$, Load Case A)	-37.2	-37.2
Case 2 ($\gamma = 0^\circ$, Load Case B)	-11.7	-50.3
Case 3 ($\gamma = 180^\circ$, Load Case A)	43.4	44.8
Case 4 ($\gamma = 180^\circ$, Load Case B)	55.1	22.0



JOB NO.: U2716-114-191

PROJECT: A5 – Sunmodo Sunturf GM

SUBJECT: Open Building Wind Loads

Design Wind Load Per ASCE 7-10

$$p = q_h G C_n$$

Velocity Pressure Exposure Coefficient, K_z :	0.57	(Table 27.3-1)
Topographic Factor, K_{zt} :	1.0	(Section 26.8.2)
Wind Directionality Factor, K_d :	0.85	(Table 26.6-1)
Ultimate Wind Speed, V [mph]:	140	

Velocity Pressure, q_h [psf]:	24.3	(Equation 27.3-1)
Gust Effect Factor, G :	0.85	(Section 26.9.1)

$\gamma = 90^\circ$ or 270°

Force Coefficient, C_N :

Horizontal Distance from Winward Edge	Roof angle		
	Load Case	Obstructed Wind Flow	
		CN	
$\leq h$	35	A	-0.8
		B	0.8
$> h, \leq 2h$	35	A	-0.6
		B	0.5
$> 2h$	35	A	-0.3
		B	0.3

Design Wind Pressure, p [psf]:

	Roof angle		
	Load Case	Obstructed Wind Flow	
$\leq h$	35	A	-16.5
		B	16.5
$> h, \leq 2h$	35	A	-12.4
		B	10.3
$> 2h$	35	A	-6.2
		B	6.2



JOB NO.: U2716-114-191

DESIGNED: STB

Foundation Option 1: Drilled Concrete Pier



JOB NO.: U2716-114-191
DATE: 08/01/19

DESIGNED: STB

PROJECT: A5 – Sunmodo Sunturf GM

Drilled Pier Design

Design Loads:

Max. Shear, V [k]:	1.7	Max. Down, P_d [k]:	3.0
Max. Moment, M [k-ft]:	0.0	Max. Uplift, P_u [k]:	2.3

Pier Properties:

Pier Diameter, b [ft]:	1.5	Volume of Concrete [ft ³]:	10
Min. Pier Diameter, b_{min} (opt'l) [ft]:		Volume of Concrete [yd ³]:	0.4
Top of Pier Elevation [ft]:	0.00	Weight of Concrete [k]:	1.5
Pier Depth, d [ft]:	5.5		
Min. Pier Depth, d_{min} (opt'l) [ft]:			
Max. Pier Depth, d_{max} (opt'l) [ft]:			

Soil Properties:

Allow. Bearing Pressure [psf]:	1,500	<u>Optional Parameters for Uplift:</u>	
1/3 increase for short term loads?	No	Skin Friction [psf]:	250 (IBC 1810.3.3.1.4)
Lateral Bearing, S [pcf]:	150	Top Length to Ignore [ft]:	0.0
Max. Lateral Bearing (opt'l) [psf]:		1/3 increase for short term loads?	No
Top Depth to Ignore [ft]:	0.0	Combine w/ Bearing:	No
1/3 increase for short term loads?	No		
1/2" deflection at t/o pier allowed:	Yes		

Check Bearing:

Bearing Capacity [k]: 6.5 **Bearing capacity OK.**

Check Uplift:

Uplift Capacity [k]: 7.8 **Uplift capacity OK.**

Check Lateral Bearing:

Applied Lateral Force, P [lb]:	1,690	
Point of Application, h [ft]:	0.0	
S_{1_max} [psf]:		
S_1 [psf]:	550	
$A = 2.34 * P / (S_1 b)$:	4.79	
Required Pier Depth, d_{reqd} [ft]:	4.8	Lateral bearing capacity OK.

Foundation Option 2: Helical Pier

The ground screws and helical piers must be tested to 1.5 times uplift and 2.0 times lateral reactions found in the table below.

Load (ASD)	Value (lbs)	Factor of Safety	Test Value (lbs)
UPLIFT	2320	1.5	3480
LATERAL	1690	2	3380

Foundation Option 3: Ground Screw

The ground screws and helical piers must be tested to 1.5 times uplift and 2.0 times lateral reactions found in the table below.

Load (ASD)	Value (lbs)	Factor of Safety	Test Value (lbs)
UPLIFT	2320	1.5	3480
LATERAL	1690	2	3380



JOB NO.: U2716-114-191

DESIGNED: STB

Foundation Option 4: Ballasted Block

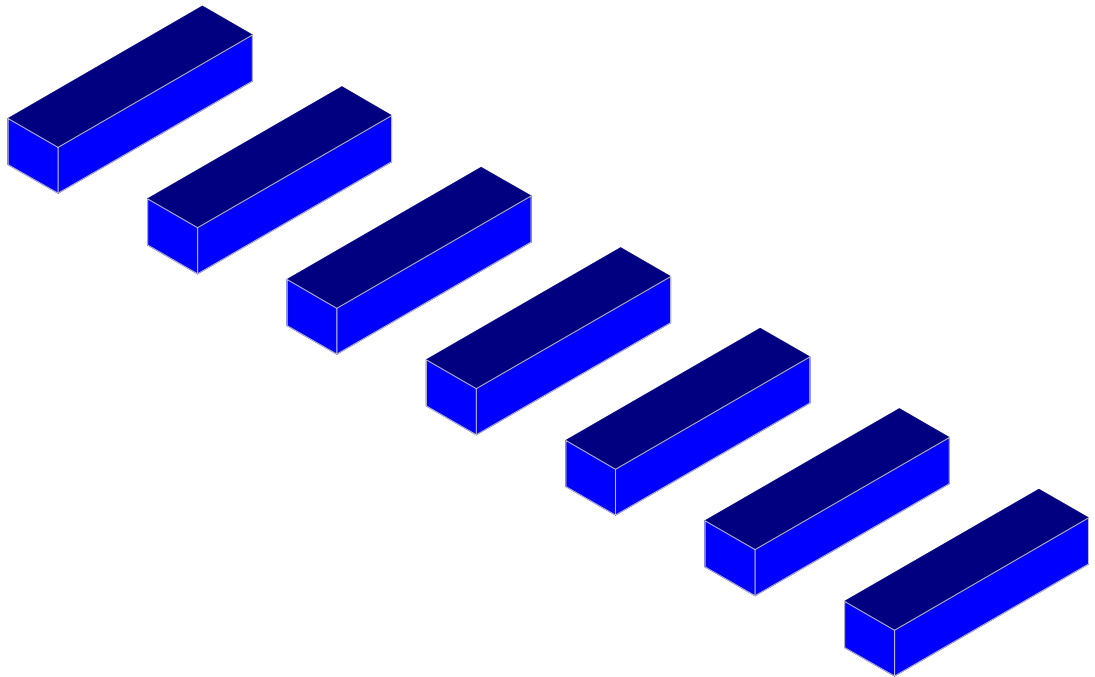

Results for LC 1, 1.0 D

Vector Structural Engineeri..	Ground Mount	SK - 2
STB		Aug 1, 2019 at 12:09 PM
U2716.114.181		New England A5.r3d

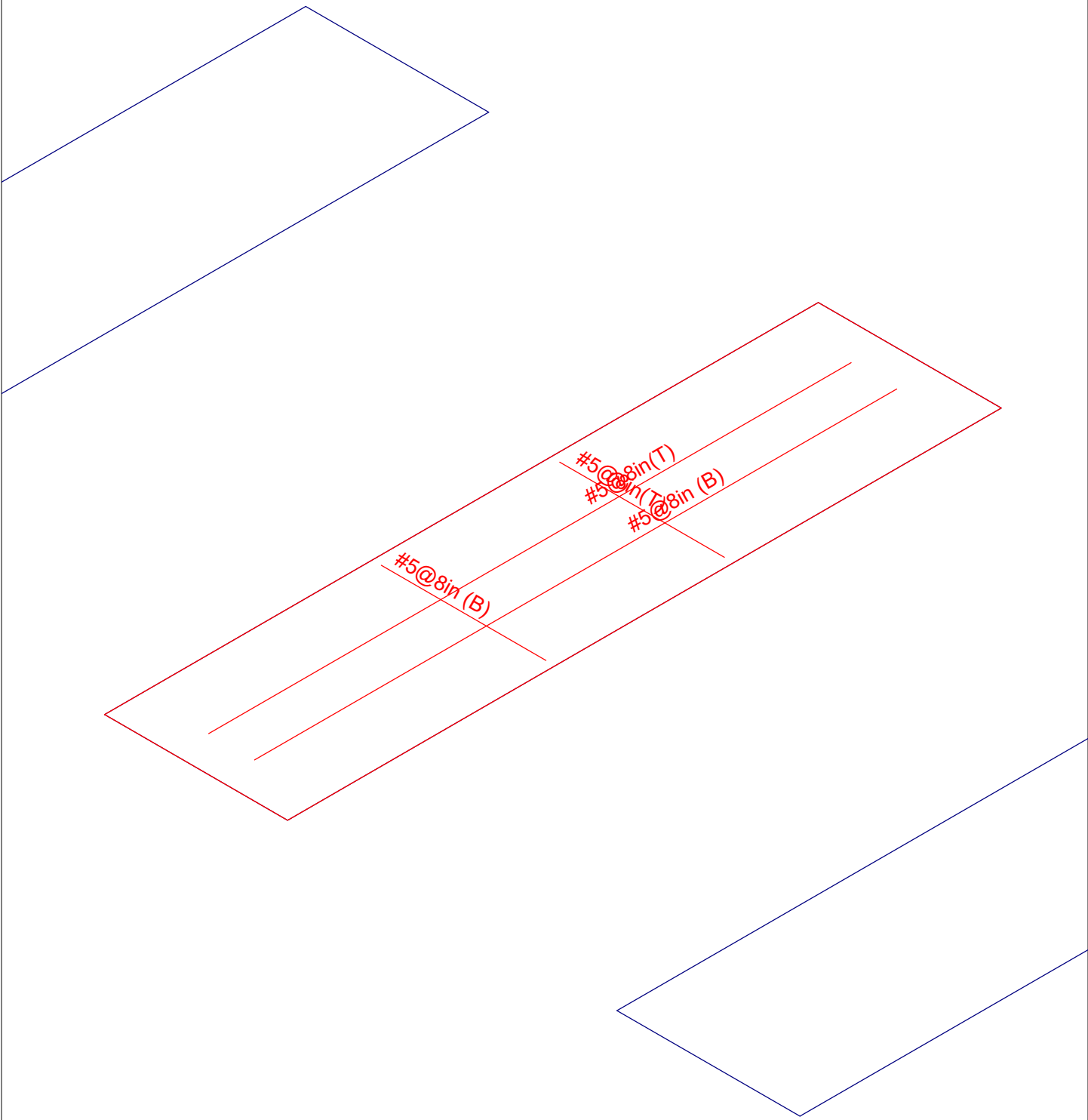

Results for LC 1, 1.0 D

Vector Structural Engineeri...	Ground Mount	SK - 1
STB		Aug 1, 2019 at 12:08 PM
U2716.114.181		New England A5.r3d



(Global) Model Settings

Display Sections for Member Calcs	5
Max Internal Sections for Member Calcs	100
Mesh Size (in)	12
Max Iterations	10
Merge Tolerance (in)	.12
Solver	Sparse Accelerated
Coefficient of Friction	.3
No. of Shear Regions	4
Shear Region Spacing Increment (in)	4
Min 1 Bar Dia Spacing for Beams?	No
Optimize footings for OTM / Sliding?	Yes
Parme Beta Factor	.65
Pile Safety Factor	3
Concrete Stress Block	Rectangular
Concrete Rebar Set	ASTM A615
Concrete Code	ACI 318-14
HR Steel Pile Code	AISC 14th(360-10): ASD
Wood Pile Code	AWC NDS-15: ASD

Concrete Properties

	Label	E [ksi]	G [ksi]	Nu	Therm (\...	Density[lb/ft^3]	fc[psi]	Lambda	Flex Stee...	Shear St...
1	Conc3000NW	3156	1372	.15	.6	145	3000	1	60000	60000
2	Conc3500NW	3409	1482	.15	.6	145	3500	1	60000	60000
3	Conc4000NW	3644	1584	.15	.6	145	4000	1	60000	60000
4	Conc3000LW	2085	907	.15	.6	109.999	3000	.75	60000	60000
5	Conc3500LW	2252	979	.15	.6	109.999	3500	.75	60000	60000
6	Conc4000LW	2408	1047	.15	.6	109.999	4000	.75	60000	60000
7	Conc2500NW	3156	1372	.15	.6	145	2500	1	60000	60000

General Design Parameters

	Label	Max Bending Chk	Max Shear Chk	Top Cover[in]	Bottom Cover[in]
1	Typical	1	1	3	3

Slab Rebar Parameters

	Label	Top Bar	Bottom Bar	Max Top Bar Sp...	Min Top Bar Sp...	Max Bot Bar Sp...	Min Bot Bar Sp...	Spacing Incr...	Rebar Options
1	Typical	#5	#5	8	8	8	8	1	Optimize

Soil Definitions

	Label	Subgrade Modulus[lb/ft^3]	Allowable Bearing[psf]	Depth Properties	Default?
1	Default	1e+5	1500	None	Yes

Point Loads and Moments (Cat 1 : DL)

	Label	Direction	Magnitude[lb,lb-ft]
1	R3D_N1_1	X	-11.981
2	R3D_N1_1	Y	216.315
3	R3D_N2	Y	183.994
4	R3D_N132_2	Y	210.684
5	R3D_N133_1	X	-1.035
6	R3D_N133_1	Y	201.84
7	R3D_N109_1	Y	194.864
8	R3D_N110A_1	Y	206.88
9	R3D_N121_1	Y	213.295

Point Loads and Moments (Cat 1 : DL) (Continued)

	Label	Direction	Magnitude[lb,lb-ft]
10	R3D_N122_1	Y	204.067
11	R3D_N133B	Y	210.368
12	R3D_N134B_1	X	-1.088
13	R3D_N134B_1	Y	204.723
14	R3D_N151_1	Y	208.078
15	R3D_N152_1	X	-2.806
16	R3D_N152_1	Y	216.841
17	R3D_N143A	X	13.773
18	R3D_N143A	Y	172.005
19	R3D_N144A	X	6.043
20	R3D_N144A	Y	138.199

Point Loads and Moments (Cat 6 : RLL)

	Label	Direction	Magnitude[lb,lb-ft]
1	R3D_N1_1	X	-67.333
2	R3D_N1_1	Y	1031.219
3	R3D_N2	X	-2.836
4	R3D_N2	Y	965.936
5	R3D_N132_2	X	-2.394
6	R3D_N132_2	Y	1044.508
7	R3D_N133_1	X	-6.442
8	R3D_N133_1	Y	1072.801
9	R3D_N109_1	X	-2.92
10	R3D_N109_1	Y	942.521
11	R3D_N109_1	Z	-1.733
12	R3D_N110A_1	Y	1106.195
13	R3D_N121_1	Y	1059.804
14	R3D_N121_1	Z	2.094
15	R3D_N122_1	X	-3.298
16	R3D_N122_1	Y	1086.104
17	R3D_N133B	X	-2.057
18	R3D_N133B	Y	1040.857
19	R3D_N133B	Z	-1.422
20	R3D_N134B_1	X	-6.538
21	R3D_N134B_1	Y	1090.396
22	R3D_N151_1	X	-2.829
23	R3D_N151_1	Y	1020.863
24	R3D_N152_1	X	-17.112
25	R3D_N152_1	Y	1164.387
26	R3D_N143A	X	78.067
27	R3D_N143A	Y	772.295
28	R3D_N144A	X	35.641
29	R3D_N144A	Y	694.668

Point Loads and Moments (Cat 16 : OL1)

	Label	Direction	Magnitude[lb,lb-ft]
1	R3D_N1_1	X	121.183
2	R3D_N1_1	Y	-3361.815
3	R3D_N1_1	Z	1910.221
4	R3D_N2	X	12.421
5	R3D_N2	Y	568.09
6	R3D_N2	Z	-95.762
7	R3D_N132_2	X	3.764
8	R3D_N132_2	Y	-3551.722
9	R3D_N132_2	Z	2117.519
10	R3D_N133_1	X	1.431

Point Loads and Moments (Cat 16 : OL1) (Continued)

	Label	Direction	Magnitude[lb.-ft]
11	R3D_N133_1	Y	627.631
12	R3D_N133_1	Z	-102.735
13	R3D_N109_1	X	2.363
14	R3D_N109_1	Y	-3453.832
15	R3D_N109_1	Z	2210.996
16	R3D_N110A_1	X	6.641
17	R3D_N110A_1	Y	680.668
18	R3D_N110A_1	Z	-102.659
19	R3D_N121_1	Y	-3599.37
20	R3D_N121_1	Z	2143.347
21	R3D_N122_1	X	3.849
22	R3D_N122_1	Y	636.787
23	R3D_N122_1	Z	-103.219
24	R3D_N133B	X	2.593
25	R3D_N133B	Y	-3579.139
26	R3D_N133B	Z	2166.731
27	R3D_N134B_1	X	3.624
28	R3D_N134B_1	Y	647.164
29	R3D_N134B_1	Z	-103.533
30	R3D_N151_1	X	2.639
31	R3D_N151_1	Y	-3729.321
32	R3D_N151_1	Z	2375.2
33	R3D_N152_1	X	17.319
34	R3D_N152_1	Y	755.338
35	R3D_N152_1	Z	-101.362
36	R3D_N143A	X	-131.677
37	R3D_N143A	Y	-2443.922
38	R3D_N143A	Z	1359.807
39	R3D_N144A	X	-45.31
40	R3D_N144A	Y	386.932
41	R3D_N144A	Z	-78.339

Point Loads and Moments (Cat 17 : OL2)

	Label	Direction	Magnitude[lb.-ft]
1	R3D_N1_1	X	155.56
2	R3D_N1_1	Y	-3751.674
3	R3D_N1_1	Z	1616.167
4	R3D_N2	X	4.576
5	R3D_N2	Y	1305.883
6	R3D_N2	Z	-80.939
7	R3D_N132_2	X	4.787
8	R3D_N132_2	Y	-3954.652
9	R3D_N132_2	Z	1788.587
10	R3D_N133_1	X	-4.396
11	R3D_N133_1	Y	1473.232
12	R3D_N133_1	Z	-86.692
13	R3D_N109_1	X	3.166
14	R3D_N109_1	Y	-3798.125
15	R3D_N109_1	Z	1860.523
16	R3D_N110A_1	X	12.66
17	R3D_N110A_1	Y	1561.753
18	R3D_N110A_1	Z	-86.49
19	R3D_N121_1	Y	-4007.863
20	R3D_N121_1	Z	1808.573
21	R3D_N122_1	Y	1491.678
22	R3D_N122_1	Z	-87.013

Point Loads and Moments (Cat 17 : OL2) (Continued)

	Label	Direction	Magnitude[lb,lb-ft]
23	R3D N133B	X	3.414
24	R3D N133B	Y	-3976.08
25	R3D N133B	Z	1827.481
26	R3D N134B 1	X	-2.613
27	R3D N134B 1	Y	1509.588
28	R3D N134B 1	Z	-87.309
29	R3D N151 1	X	3.557
30	R3D N151 1	Y	-4096.415
31	R3D N151 1	Z	1998.466
32	R3D N152 1	X	-1.054
33	R3D N152 1	Y	1675.474
34	R3D N152 1	Z	-85.393
35	R3D N143A	X	-169.519
36	R3D N143A	Y	-2738.278
37	R3D N143A	Z	1151.652
38	R3D N144A	X	-9.86
39	R3D N144A	Y	923.426
40	R3D N144A	Z	-66.309

Point Loads and Moments (Cat 18 : OL3)

	Label	Direction	Magnitude[lb,lb-ft]
1	R3D N1 1	X	-145.639
2	R3D N1 1	Y	4019.84
3	R3D N1 1	Z	-2265.419
4	R3D N2	X	-14.516
5	R3D N2	Y	-703.655
6	R3D N2	Z	113.566
7	R3D N132 2	X	-4.522
8	R3D N132 2	Y	4246.593
9	R3D N132 2	Z	-2511.154
10	R3D N133 1	X	-1.493
11	R3D N133 1	Y	-778.509
12	R3D N133 1	Z	121.83
13	R3D N109 1	X	-2.845
14	R3D N109 1	Y	4127.827
15	R3D N109 1	Z	-2621.754
16	R3D N110A 1	X	-8.131
17	R3D N110A 1	Y	-842.992
18	R3D N110A 1	Z	121.735
19	R3D N121 1	Y	4303.568
20	R3D N121 1	Z	-2541.717
21	R3D N122 1	X	-4.47
22	R3D N122 1	Y	-789.756
23	R3D N122 1	Z	122.401
24	R3D N133B	X	-3.119
25	R3D N133B	Y	4279.044
26	R3D N133B	Z	-2569.418
27	R3D N134B 1	X	-4.092
28	R3D N134B 1	Y	-802.395
29	R3D N134B 1	Z	122.774
30	R3D N151 1	X	-3.177
31	R3D N151 1	Y	4456.908
32	R3D N151 1	Z	-2816.456
33	R3D N152 1	X	-19.97
34	R3D N152 1	Y	-933.38
35	R3D N152 1	Z	120.197

Point Loads and Moments (Cat 20 : OL5) (Continued)

	Label	Direction	Magnitude[lb,lb-ft]
5	R3D_N2	Y	-246.757
6	R3D_N2	Z	38.587
7	R3D_N132_2	Y	597.56
8	R3D_N132_2	Z	-354.137
9	R3D_N133_1	X	-1.087
10	R3D_N133_1	Y	-103.656
11	R3D_N133_1	Z	17.626
12	R3D_N109_1	X	1.962
13	R3D_N109_1	Y	1281.267
14	R3D_N109_1	Z	-812.305
15	R3D_N110A_1	Y	-244.711
16	R3D_N110A_1	Z	35.398
17	R3D_N121_1	X	3.655
18	R3D_N121_1	Y	825.474
19	R3D_N121_1	Z	-494.165
20	R3D_N122_1	X	3.969
21	R3D_N122_1	Y	-146.969
22	R3D_N122_1	Z	25.742
23	R3D_N133B	Y	575.797
24	R3D_N133B	Z	-351.517
25	R3D_N134B_1	X	-2.755
26	R3D_N134B_1	Y	-103.564
27	R3D_N134B_1	Z	19.346
28	R3D_N151_1	X	1.565
29	R3D_N151_1	Y	602.524
30	R3D_N151_1	Z	-395.726
31	R3D_N152_1	X	-3.747
32	R3D_N152_1	Y	-125.87
33	R3D_N152_1	Z	17.016
34	R3D_N143A	X	32.511
35	R3D_N143A	Y	425.225
36	R3D_N143A	Z	-226.862
37	R3D_N144A	X	6.295
38	R3D_N144A	Y	-65.348
39	R3D_N144A	Z	13.101

Point Loads and Moments (Cat 21 : OL6)

	Label	Direction	Magnitude[lb,lb-ft]
1	R3D_N1_1	X	39.808
2	R3D_N1_1	Y	-1430.722
3	R3D_N1_1	Z	825.713
4	R3D_N2	X	3.305
5	R3D_N2	Y	243.919
6	R3D_N2	Z	-37.239
7	R3D_N132_2	Y	-595.647
8	R3D_N132_2	Z	353.244
9	R3D_N133_1	X	1.14
10	R3D_N133_1	Y	103.977
11	R3D_N133_1	Z	-17.501
12	R3D_N109_1	X	-2.369
13	R3D_N109_1	Y	-1109.917
14	R3D_N109_1	Z	710.949
15	R3D_N110A_1	X	-2.738
16	R3D_N110A_1	Y	214.112
17	R3D_N110A_1	Z	-32.197
18	R3D_N121_1	X	-2.569



Point Loads and Moments (Cat 21 : OL6) (Continued)

	Label	Direction	Magnitude[lb.-ft]
19	R3D N121 1	Y	-736.247
20	R3D N121 1	Z	439.819
21	R3D N122 1	Y	129.723
22	R3D N122 1	Z	-23.495
23	R3D N133B	Y	-587.784
24	R3D N133B	Z	358.05
25	R3D N134B 1	X	1.95
26	R3D N134B 1	Y	105.592
27	R3D N134B 1	Z	-18.85
28	R3D N151 1	X	-1.449
29	R3D N151 1	Y	-603.995
30	R3D N151 1	Z	395.79
31	R3D N152 1	X	3.636
32	R3D N152 1	Y	125.796
33	R3D N152 1	Z	-16.986
34	R3D N143A	X	-31.835
35	R3D N143A	Y	-424.077
36	R3D N143A	Z	226.847
37	R3D N144A	X	-6.393
38	R3D N144A	Y	65.292
39	R3D N144A	Z	-13.092

Slabs

	Label	Thickness [in]	Material	Local Axis Angle [deg]	Analysis Offset [in]
1	S1	24	Conc2500NW	0	0
2	S2	24	Conc2500NW	0	0
3	S3	24	Conc2500NW	0	0
4	S4	24	Conc2500NW	0	0
5	S5	24	Conc2500NW	0	0
6	S6	24	Conc2500NW	0	0
7	S7	24	Conc2500NW	0	0

Load Combinations

	Label	Solve	Service	A..SF	Cat..Fa...	Cat..Fa...	Cat..Fa...	Cat..Fa...	Cat..Fa...	Cat..Fa...	Cat..Fa...	Cat..Fa...	Cat..Fa...	C...	F...	C...	F...
1	1.0 D	Yes	Yes	1.5	DL	1											
2	1.0 D + 1....	Yes	Yes	1.5	DL	1	RLL	1									
3	1.0 D + 0....	Yes	Yes	1.5	DL	1	RLL	OL1	.6								
4	1.0 D + 0....	Yes	Yes	1.5	DL	1	RLL	OL2	.6								
5	1.0 D + 0....	Yes	Yes	1.5	DL	1	RLL	OL3	.6								
6	1.0 D + 0....	Yes	Yes	1.5	DL	1	RLL	OL4	.6								
7	1.0 D + 0....	Yes	Yes	1.5	DL	1	RLL	OL5	.6								
8	1.0 D + 0....	Yes	Yes	1.5	DL	1	RLL	OL6	.6								
9	1.0 D + 0....	Yes	Yes	1.5	DL	1	RLL	.75	OL1	.45							
10	1.0 D + 0....	Yes	Yes	1.5	DL	1	RLL	.75	OL2	.45							
11	1.0 D + 0....	Yes	Yes	1.5	DL	1	RLL	.75	OL3	.45							
12	1.0 D + 0....	Yes	Yes	1.5	DL	1	RLL	.75	OL4	.45							
13	1.0 D + 0....	Yes	Yes	1.5	DL	1	RLL	.75	OL5	.45							
14	1.0 D + 0....	Yes	Yes	1.5	DL	1	RLL	.75	OL6	.45							
15	0.6 D + 0....	Yes	Yes		DL	.6	RLL	OL1	.6								
16	0.6 D + 0....	Yes	Yes		DL	.6	RLL	OL2	.6								
17	0.6 D + 0....	Yes	Yes		DL	.6	RLL	OL3	.6								
18	0.6 D + 0....	Yes	Yes		DL	.6	RLL	OL4	.6								
19	0.6 D + 0....	Yes	Yes		DL	.6	RLL	OL5	.6								
20	0.6 D + 0....	Yes	Yes		DL	.6	RLL	OL6	.6								
21																	
22	1.4D	Yes			DL	1.4											



Slab Overturning Safety Factors (Continued)

LC	Slab	Angle[deg]	Mo-xx[lb-ft]	Ms-xx[lb-ft]	Mo-zz[lb-ft]	Ms-zz[lb-ft]	Ms-xx/Mo-xx	Ms-zz/Mo-zz
13	2	S6	0	0	47801.216	0	12144.159	9.999+
14	2	S7	0	0	42826.568	0	10790.364	9.999+
15	3	S1	0	18138.999	36502.843	2255.619	9360.301	2.012
16	3	S2	0	18841.212	36361.988	2090.678	9338.132	1.93
17	3	S3	0	19511.993	36508.288	2226.556	9357.654	1.871
18	3	S4	0	19431.209	36485.375	2206.441	9356.993	1.878
19	3	S5	0	19256.349	36483.625	2199.303	9353.677	1.895
20	3	S6	0	20322.512	36484.85	2254.437	9372.714	1.795
21	3	S7	0	13164.769	36072.287	1755.126	9263.34	2.74
22	4	S1	0	19050.211	36502.843	2026.506	9360.301	1.916
23	4	S2	0	19334.103	36361.988	1696.27	9338.132	1.881
24	4	S3	0	20361.921	36508.288	1887.139	9357.654	1.793
25	4	S4	0	20212.402	36485.375	1850.831	9356.993	1.805
26	4	S5	0	20094.192	36483.625	1861.534	9353.677	1.816
27	4	S6	0	20860.224	36484.85	1818.71	9372.714	1.749
28	4	S7	0	13888.911	36072.287	1576.394	9263.34	2.597
29	5	S1	0	2246.476	36320.725	0	12039.626	9.999+
30	5	S2	0	3251.408	36475.563	0	11814.93	9.999+
31	5	S3	0	2724.092	36481.539	0	11998.378	9.999+
32	5	S4	0	2842.742	36482.319	0	11973.133	9.999+
33	5	S5	0	2686.556	36459.031	0	11961.959	9.999+
34	5	S6	0	3621.687	36578.668	0	12043.137	9.999+
35	5	S7	0	1425.678	35872.758	0	10762.547	9.999+
36	6	S1	0	0	37243.289	0	11571.874	9.999+
37	6	S2	0	0	37252.008	0	11543.168	9.999+
38	6	S3	0	0	37501.388	0	11637.17	9.999+
39	6	S4	0	0	37451.167	0	11633.105	9.999+
40	6	S5	0	0	37477.043	0	11608.112	9.999+
41	6	S6	0	0	37201.25	0	11760.405	9.999+
42	6	S7	0	0	36697.685	0	10530.772	9.999+
43	7	S1	0	804.292	36320.725	0	10308.557	9.999+
44	7	S2	0	926.404	36475.563	0	10113.194	9.999+
45	7	S3	0	505.408	36481.539	0	9857.383	9.999+
46	7	S4	0	364.238	36482.319	0	9714.474	9.999+
47	7	S5	0	349.231	36459.031	0	9725.41	9.999+
48	7	S6	0	505.111	36578.668	0	9732.823	9.999+
49	7	S7	0	176.021	35872.758	0	9407.417	9.999+
50	8	S1	0	7737.193	36502.843	941.838	9360.301	4.718
51	8	S2	0	6060.407	36361.988	677.982	9338.132	6
52	8	S3	0	3990.455	36508.288	457.975	9357.654	9.149
53	8	S4	0	3192.157	36485.375	363.985	9356.993	9.999+
54	8	S5	0	3227.989	36483.625	370.12	9353.677	9.999+
55	8	S6	0	3300.93	36484.85	361.274	9372.714	9.999+
56	8	S7	0	2275.725	36072.287	314.963	9263.34	9.999+
57	9	S1	0	13604.25	43905.771	1691.714	11337.887	3.227
58	9	S2	0	14130.909	43382.033	1568.008	11263.182	3.07
59	9	S3	0	14633.995	44218.349	1669.917	11374.39	3.022
60	9	S4	0	14573.407	44089.488	1654.831	11367.936	3.025
61	9	S5	0	14442.262	44088.169	1649.477	11351.908	3.053
62	9	S6	0	15241.884	44047.603	1690.828	11451.298	2.89
63	9	S7	0	9873.576	41584.121	1316.345	10809.181	4.212
64	10	S1	0	14287.658	43905.771	1519.879	11337.887	3.073
65	10	S2	0	14500.577	43382.033	1272.203	11263.182	2.992
66	10	S3	0	15271.441	44218.349	1415.354	11364.496	2.895
67	10	S4	0	15159.301	44089.488	1386.681	11337.797	2.908
68	10	S5	0	15070.644	44088.169	1395.447	11321.259	2.925
69	10	S6	0	15645.168	44047.603	1359.526	11380.248	2.815



Slab Overturning Safety Factors (Continued)

LC	Slab	Angle[deg]	Mo-xx[lb-ft]	Ms-xx[lb-ft]	Mo-zz[lb-ft]	Ms-zz[lb-ft]	Ms-xx/Mo-xx	Ms-zz/Mo-zz	
70	10	S7	0	10416.684	41584.121	1182.295	10809.181	3.992	9.143
71	11	S1	0	1684.857	43522.018	0	13347.381	9.999+	9.999+
72	11	S2	0	2438.556	44436.78	0	13120.781	9.999+	9.999+
73	11	S3	0	2043.069	44463.457	0	13354.933	9.999+	9.999+
74	11	S4	0	2132.057	44463.021	0	13330.041	9.999+	9.999+
75	11	S5	0	2014.917	44337.333	0	13308.12	9.999+	9.999+
76	11	S6	0	2716.265	44995.579	0	13454.115	9.999+	9.999+
77	11	S7	0	1069.259	41088.116	0	11572.646	9.999+	9.999+
78	12	S1	0	0	44213.941	0	12996.567	9.999+	9.999+
79	12	S2	0	0	45019.114	0	12916.96	9.999+	9.999+
80	12	S3	0	0	45228.344	0	13084.027	9.999+	9.999+
81	12	S4	0	0	45189.657	0	13075.02	9.999+	9.999+
82	12	S5	0	0	45100.842	0	13042.735	9.999+	9.999+
83	12	S6	0	0	45462.515	0	13242.066	9.999+	9.999+
84	12	S7	0	0	41706.81	0	11398.814	9.999+	9.999+
85	13	S1	0	603.219	43522.018	0	12049.079	9.999+	9.999+
86	13	S2	0	694.803	44436.78	0	11844.479	9.999+	9.999+
87	13	S3	0	379.056	44463.457	0	11749.187	9.999+	9.999+
88	13	S4	0	273.179	44463.021	0	11636.047	9.999+	9.999+
89	13	S5	0	261.923	44337.333	0	11630.707	9.999+	9.999+
90	13	S6	0	378.833	44995.579	0	11721.38	9.999+	9.999+
91	13	S7	0	132.016	41088.116	0	10556.298	9.999+	9.999+
92	14	S1	0	5802.895	43905.771	706.379	11337.887	7.566	9.999+
93	14	S2	0	4545.306	43382.033	508.487	11254.423	9.544	9.999+
94	14	S3	0	2992.842	44218.349	343.482	11364.496	9.999+	9.999+
95	14	S4	0	2394.117	44089.488	272.989	11367.936	9.999+	9.999+
96	14	S5	0	2420.992	44088.169	277.59	11351.908	9.999+	9.999+
97	14	S6	0	2475.698	44047.603	270.956	11451.298	9.999+	9.999+
98	14	S7	0	1706.794	41584.121	236.222	10809.181	9.999+	9.999+
99	15	S1	0	18138.999	21901.706	2255.619	5616.181	1.207	2.49
100	15	S2	0	18841.212	21817.193	2090.678	5602.879	1.158	2.68
101	15	S3	0	19511.993	21904.973	2226.556	5614.593	1.123	2.522
102	15	S4	0	19431.209	21891.225	2206.441	5614.196	1.127	2.544
103	15	S5	0	19256.349	21890.175	2199.303	5612.206	1.137	2.552
104	15	S6	0	20322.512	21890.91	2254.437	5623.628	1.077	2.494
105	15	S7	0	13164.769	21643.372	1755.126	5558.004	1.644	3.167
106	16	S1	0	19050.211	21901.706	2026.506	5616.181	1.15	2.771
107	16	S2	0	19334.103	21817.193	1696.27	5602.879	1.128	3.303
108	16	S3	0	20361.921	21904.973	1887.139	5614.593	1.076	2.975
109	16	S4	0	20212.402	21891.225	1850.831	5614.196	1.083	3.033
110	16	S5	0	20094.192	21890.175	1861.534	5612.206	1.089	3.015
111	16	S6	0	20860.224	21890.91	1818.71	5623.628	1.049	3.092
112	16	S7	0	13888.911	21643.372	1576.394	5558.004	1.558	3.526
113	17	S1	0	2246.476	21792.435	0	8295.505	9.701	9.999+
114	17	S2	0	3251.408	21885.338	0	8079.677	6.731	9.999+
115	17	S3	0	2724.092	21888.923	0	8255.316	8.035	9.999+
116	17	S4	0	2842.742	21889.391	0	8230.336	7.7	9.999+
117	17	S5	0	2686.556	21875.419	0	8220.488	8.143	9.999+
118	17	S6	0	3621.687	21947.201	0	8294.051	6.06	9.999+
119	17	S7	0	1425.678	21523.655	0	7088.917	9.999+	9.999+
120	18	S1	0	0	22715	0	7827.753	9.999+	9.999+
121	18	S2	0	0	22661.783	0	7807.915	9.999+	9.999+
122	18	S3	0	0	22908.772	0	7894.108	9.999+	9.999+
123	18	S4	0	0	22858.239	0	7890.308	9.999+	9.999+
124	18	S5	0	0	22893.43	0	7866.641	9.999+	9.999+
125	18	S6	0	0	22569.783	0	8011.319	9.999+	9.999+
126	18	S7	0	0	22348.581	0	6857.142	9.999+	9.999+

Slab Overturning Safety Factors (Continued)

	LC	Slab	Angle[deg]	Mo-xx[lb-ft]	Ms-xx[lb-ft]	Mo-zz[lb-ft]	Ms-zz[lb-ft]	Ms-xx/Mo-xx	Ms-zz/Mo-zz
127	19	S1	0	804.292	21792.435	0	6564.436	9.999+	9.999+
128	19	S2	0	926.404	21885.338	0	6377.942	9.999+	9.999+
129	19	S3	0	505.408	21888.923	0	6114.321	9.999+	9.999+
130	19	S4	0	364.238	21889.391	0	5971.677	9.999+	9.999+
131	19	S5	0	349.231	21875.419	0	5983.939	9.999+	9.999+
132	19	S6	0	505.111	21947.201	0	5983.738	9.999+	9.999+
133	19	S7	0	176.021	21523.655	0	5733.786	9.999+	9.999+
134	20	S1	0	7737.193	21901.706	941.838	5616.181	2.831	5.963
135	20	S2	0	6060.407	21817.193	677.982	5602.879	3.6	8.264
136	20	S3	0	3990.455	21904.973	457.975	5614.593	5.489	9.999+
137	20	S4	0	3192.157	21891.225	363.985	5614.196	6.858	9.999+
138	20	S5	0	3227.989	21890.175	370.12	5612.206	6.781	9.999+
139	20	S6	0	3300.93	21890.91	361.274	5623.628	6.632	9.999+
140	20	S7	0	2275.725	21643.372	314.963	5558.004	9.511	9.999+

Slab Sliding Safety Factors

	LC	Slab	Angle[deg]	Va-xx[lb]	Vr-xx[lb]	Va-zz[lb]	Vr-zz[lb]	SR-xx	SR-zz
1	1	S1	0	11.981	2240.721	0	2240.721	9.999+	9.999+
2	1	S2	0	0	2241.152	0	2241.152	9.999+	9.999+
3	1	S3	0	0	2245.837	0	2245.837	9.999+	9.999+
4	1	S4	0	1.088	2245.156	0	2245.156	9.999+	9.999+
5	1	S5	0	1.035	2244.386	0	2244.386	9.999+	9.999+
6	1	S6	0	2.806	2248.104	0	2248.104	9.999+	9.999+
7	1	S7	0	19.816	2213.69	0	2213.69	9.999+	9.999+
8	2	S1	0	82.15	2839.868	0	2839.868	9.999+	9.999+
9	2	S2	0	2.92	2855.766	1.733	2855.766	9.999+	9.999+
10	2	S3	0	3.298	2889.609	2.094	2889.609	9.999+	9.999+
11	2	S4	0	9.684	2884.532	1.422	2884.532	9.999+	9.999+
12	2	S5	0	9.871	2879.578	0	2879.578	9.999+	9.999+
13	2	S6	0	22.748	2903.679	0	2903.679	9.999+	9.999+
14	2	S7	0	133.524	2653.779	0	2653.779	9.999+	9.999+
15	3	S1	0	68.181	1737.851	1088.675	1737.851	9.999+	1.596
16	3	S2	0	5.403	1741.982	1265.002	1741.982	9.999+	1.377
17	3	S3	0	2.309	1712.572	1224.076	1712.572	9.999+	1.399
18	3	S4	0	2.642	1717.4	1237.919	1717.4	9.999+	1.387
19	3	S5	0	2.082	1718.049	1208.87	1718.049	9.999+	1.421
20	3	S6	0	9.169	1712.787	1364.303	1712.787	9.999+	1.255
21	3	S7	0	86.376	1843.432	768.881	1843.432	9.999+	2.398
22	4	S1	0	84.1	1800.479	921.137	1800.479	9.999+	1.955
23	4	S2	0	9.496	1838.605	1064.42	1838.605	9.999+	1.727
24	4	S3	0	0	1792.924	1032.936	1792.924	9.999+	1.736
25	4	S4	0	.607	1801.187	1044.103	1801.187	9.999+	1.725
26	4	S5	0	.801	1797.73	1021.137	1797.73	9.999+	1.761
27	4	S6	0	1.304	1812.335	1147.844	1812.335	9.999+	1.579
28	4	S7	0	87.811	1887.017	651.206	1887.017	9.999+	2.898
29	5	S1	0	108.074	2837.635	1291.112	2837.635	9.999+	2.198
30	5	S2	0	6.586	2832.422	1500.011	2832.422	9.999+	1.888
31	5	S3	0	2.682	2878.323	1451.59	2878.323	9.999+	1.983
32	5	S4	0	5.415	2870.953	1467.986	2870.953	9.999+	1.956
33	5	S5	0	4.645	2868.641	1433.595	2868.641	9.999+	2.001
34	5	S6	0	16.695	2882.339	1617.755	2882.339	9.999+	1.782
35	5	S7	0	146.399	2653.283	911.876	2653.283	9.999+	2.91
36	6	S1	0	69.945	2743.676	1116.258	2743.676	9.999+	2.458
37	6	S2	0	.854	2769.95	1302.119	2769.95	9.999+	2.127
38	6	S3	0	3.703	2791.143	1257.46	2791.143	9.999+	2.22
39	6	S4	0	7.207	2788.486	1272.121	2788.486	9.999+	2.192



Company : Vector Structural Engineering
 Designer : STB
 Job Number : U2716.114.181
 Model Name : Ground Mount

Aug 1, 2019
 12:09 PM
 Checked By: JSP

Slab Sliding Safety Factors (Continued)

	LC	Slab	Angle[deg]	Va-xx[lb]	Vr-xx[lb]	Va-zz[lb]	Vr-zz[lb]	SR-xx	SR-zz
40	6	S5	0	6.292	2782.927	1240.954	2782.927	9.999+	2.243
41	6	S6	0	22.484	2811.705	1404.446	2811.705	9.999+	2.002
42	6	S7	0	113.453	2581.843	787.804	2581.843	9.999+	3.277
43	7	S1	0	38.813	2455.423	475.204	2455.423	9.999+	5.167
44	7	S2	0	1.177	2427.732	466.144	2427.732	9.999+	5.208
45	7	S3	0	4.575	2367.968	281.054	2367.968	9.999+	8.425
46	7	S4	0	2.741	2330.158	199.302	2330.158	9.999+	9.999+
47	7	S5	0	1.688	2333.288	201.906	2333.288	9.999+	9.999+
48	7	S6	0	4.115	2333.902	227.226	2333.902	9.999+	9.999+
49	7	S7	0	43.1	2278.468	128.257	2278.468	9.999+	9.999+
50	8	S1	0	13.887	2027.097	473.084	2027.097	9.999+	4.285
51	8	S2	0	3.064	2079.907	407.251	2079.907	9.999+	5.107
52	8	S3	0	1.541	2136.663	249.795	2136.663	9.999+	8.554
53	8	S4	0	.082	2158.361	203.52	2158.361	9.999+	9.999+
54	8	S5	0	.352	2155.885	201.446	2155.885	9.999+	9.999+
55	8	S6	0	1.494	2162.029	227.283	2162.029	9.999+	9.513
56	8	S7	0	3.121	2149.109	128.253	2149.109	9.999+	9.999+
57	9	S1	0	4.486	2312.928	816.507	2312.928	9.999+	2.833
58	9	S2	0	1.862	2327.736	947.452	2327.736	9.999+	2.457
59	9	S3	0	.742	2328.718	919.628	2328.718	9.999+	2.532
60	9	S4	0	4.737	2328.871	927.372	2328.871	9.999+	2.511
61	9	S5	0	5.325	2326.028	906.653	2326.028	9.999+	2.566
62	9	S6	0	8.781	2338.298	1023.227	2338.298	9.999+	2.285
63	9	S7	0	25.453	2266.063	576.661	2266.063	9.999+	3.93
64	10	S1	0	7.453	2359.899	690.853	2359.899	9.999+	3.416
65	10	S2	0	4.932	2400.202	797.015	2400.202	9.999+	3.011
66	10	S3	0	2.474	2388.981	776.273	2388.981	9.999+	3.078
67	10	S4	0	7.174	2391.711	782.01	2391.711	9.999+	3.058
68	10	S5	0	7.487	2385.788	765.853	2385.788	9.999+	3.115
69	10	S6	0	16.636	2412.959	860.883	2412.959	9.999+	2.803
70	10	S7	0	24.377	2298.752	488.404	2298.752	9.999+	4.707
71	11	S1	0	136.678	3137.766	968.334	3137.766	9.999+	3.24
72	11	S2	0	7.129	3145.565	1126.309	3145.565	9.999+	2.793
73	11	S3	0	4.485	3203.031	1087.121	3203.031	9.999+	2.946
74	11	S4	0	10.78	3194.036	1102.056	3194.036	9.999+	2.898
75	11	S5	0	10.369	3188.971	1075.196	3188.971	9.999+	2.966
76	11	S6	0	28.179	3215.462	1213.317	3215.462	9.999+	2.65
77	11	S7	0	200.034	2873.451	683.907	2873.451	9.999+	4.202
78	12	S1	0	108.081	3067.297	837.194	3067.297	9.999+	3.664
79	12	S2	0	2.83	3098.712	977.889	3098.712	9.999+	3.169
80	12	S3	0	5.251	3137.646	941.524	3137.646	9.999+	3.333
81	12	S4	0	12.124	3132.185	955.158	3132.185	9.999+	3.279
82	12	S5	0	11.605	3124.686	930.716	3124.686	9.999+	3.357
83	12	S6	0	32.521	3162.486	1053.334	3162.486	9.999+	3.002
84	12	S7	0	175.325	2819.872	590.853	2819.872	9.999+	4.773
85	13	S1	0	84.732	2851.108	356.403	2851.108	9.999+	8
86	13	S2	0	1.307	2842.048	350.908	2842.048	9.999+	8.099
87	13	S3	0	.957	2820.264	209.22	2820.264	9.999+	9.999+
88	13	S4	0	8.775	2788.439	150.544	2788.439	9.999+	9.999+
89	13	S5	0	8.152	2787.457	151.43	2787.457	9.999+	9.999+
90	13	S6	0	18.744	2804.134	170.419	2804.134	9.999+	9.999+
91	13	S7	0	122.56	2592.34	96.192	2592.34	9.999+	9.999+
92	14	S1	0	45.207	2529.863	354.813	2529.863	9.999+	7.13
93	14	S2	0	4.488	2581.179	304.139	2581.179	9.999+	8.487
94	14	S3	0	3.63	2646.786	188.917	2646.786	9.999+	9.999+
95	14	S4	0	6.657	2659.592	151.573	2659.592	9.999+	9.999+
96	14	S5	0	7.15	2654.405	151.084	2654.405	9.999+	9.999+



Company:		Date:	5/14/2018
Engineer:		Page:	1/6
Project:			
Address:			
Phone:			
E-mail:			

1. Project information

Customer company:
Customer contact name:
Customer e-mail:
Comment:

Project description:
Location:
Fastening description:

2. Input Data & Anchor Parameters

General

Design method: ACI 318-14
Units: Imperial units

Anchor Information:

Anchor type: Bonded anchor
Material: F1554 Grade 36
Diameter (inch): 0.375
Effective Embedment depth, h_{ef} (inch): 6.000
Code report: ICC-ES ESR-4057
Anchor category: -
Anchor ductility: Yes
 h_{min} (inch): 7.25
 c_{ac} (inch): 10.99
 c_{min} (inch): 1.75
 s_{min} (inch): 3.00

Base Material

Concrete: Normal-weight
Concrete thickness, h (inch): 30.00
State: Cracked
Compressive strength, f'_c (psi): 2500
 $\Psi_{c,v}$: 1.0
Reinforcement condition: B tension, B shear
Supplemental reinforcement: Not applicable
Reinforcement provided at corners: No
Ignore concrete breakout in tension: No
Ignore concrete breakout in shear: No
Hole condition: Dry concrete
Inspection: Periodic
Temperature range, Short/Long: 150/110°F
Ignore 6do requirement: Not applicable
Build-up grout pad: No

Base Plate

Length x Width x Thickness (inch): 4.75 x 4.75 x 0.31

Recommended Anchor

Anchor Name: SET-3G - SET-3G w/ 3/8"Ø F1554 Gr. 36
Code Report: ICC-ES ESR-4057





Company:		Date:	5/14/2018
Engineer:		Page:	2/6
Project:			
Address:			
Phone:			
E-mail:			

Load and Geometry

Load factor source: ACI 318 Section 5.3

Load combination: not set

Seismic design: No

Anchors subjected to sustained tension: No

Apply entire shear load at front row: No

Anchors only resisting wind and/or seismic loads: No

Strength level loads:

N_{ua} [lb]: 3870

V_{uax} [lb]: 175

V_{uay} [lb]: -2820

M_{ux} [ft-lb]: 0

M_{uy} [ft-lb]: 0

M_{uz} [ft-lb]: 0

<Figure 1>

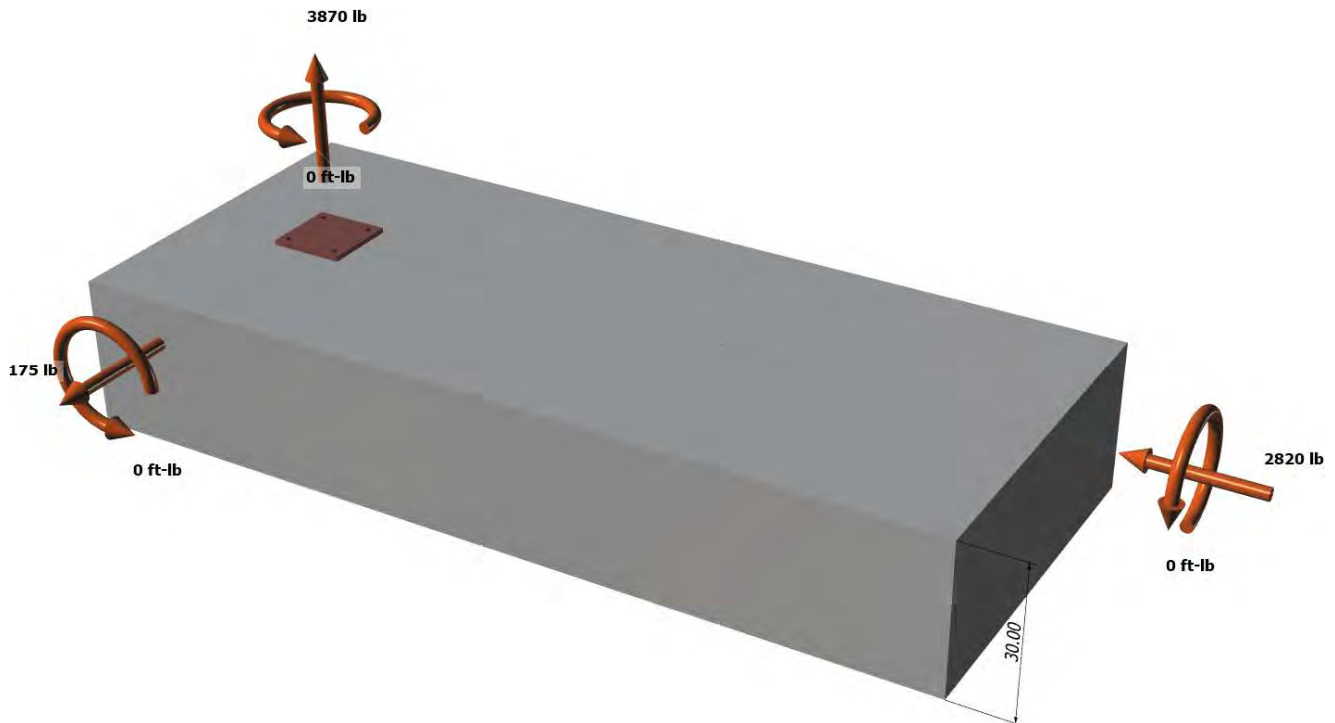



Company:		Date:	5/14/2018
Engineer:		Page:	3/6
Project:			
Address:			
Phone:			
E-mail:			

<Figure 2>





Company:		Date:	5/14/2018
Engineer:		Page:	4/6
Project:			
Address:			
Phone:			
E-mail:			

3. Resulting Anchor Forces

Anchor	Tension load, N _{ua} (lb)	Shear load x, V _{uax} (lb)	Shear load y, V _{uay} (lb)	Shear load combined, $\sqrt{(V_{uax})^2 + (V_{uay})^2}$ (lb)
1	967.5	43.8	-705.0	706.4
2	967.5	43.8	-705.0	706.4
3	967.5	43.8	-705.0	706.4
4	967.5	43.8	-705.0	706.4
Sum	3870.0	175.0	-2820.0	2825.4

Maximum concrete compression strain (%): 0.00
 Maximum concrete compression stress (psi): 0
 Resultant tension force (lb): 3870
 Resultant compression force (lb): 0
 Eccentricity of resultant tension forces in x-axis, e'_{Nx} (inch): 0.00
 Eccentricity of resultant tension forces in y-axis, e'_{Ny} (inch): 0.00
 Eccentricity of resultant shear forces in x-axis, e'_{Vx} (inch): 0.00
 Eccentricity of resultant shear forces in y-axis, e'_{Vy} (inch): 0.00

<Figure 3>

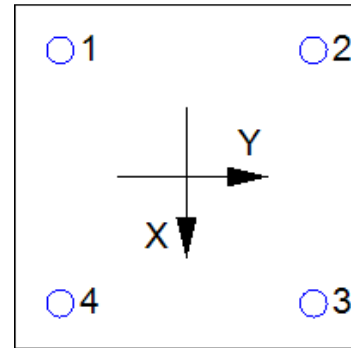

4. Steel Strength of Anchor in Tension (Sec. 17.4.1)

N _{sa} (lb)	φ	φN _{sa} (lb)
4525	0.75	3394

5. Concrete Breakout Strength of Anchor in Tension (Sec. 17.4.2)

$$N_b = K_c \lambda_a \sqrt{f_c} h_{ef}^{1.5} \text{ (Eq. 17.4.2.2a)}$$

K _c	λ _a	f _c (psi)	h _{ef} (in)	N _b (lb)
17.0	1.00	2500	6.000	12492

$$\phi N_{cbg} = \phi (A_{Nc} / A_{Nco}) \psi_{ec,N} \psi_{ed,N} \psi_{c,N} \psi_{cp,N} N_b \text{ (Sec. 17.3.1 \& Eq. 17.4.2.1b)}$$

A _{Nc} (in ²)	A _{Nco} (in ²)	C _{a,min} (in)	ψ _{ec,N}	ψ _{ed,N}	ψ _{c,N}	ψ _{cp,N}	N _b (lb)	φ	φN _{cbg} (lb)
424.63	324.00	7.25	1.000	0.942	1.00	1.000	12492	0.65	10021

6. Adhesive Strength of Anchor in Tension (Sec. 17.4.5)

$$\tau_{k,cr} = \tau_{k,cr,short-term} K_{sat} (f_c / 2,500)^n$$

τ _{k,cr} (psi)	f _{short-term}	K _{sat}	f _c (psi)	n	τ _{k,cr} (psi)
1346	1.00	1.00	2500	0.24	1346

$$N_{ba} = \lambda_a \tau_{cr} \pi d_a h_{ef} \text{ (Eq. 17.4.5.2)}$$

λ _a	τ _{cr} (psi)	d _a (in)	h _{ef} (in)	N _{ba} (lb)
1.00	1346	0.38	6.000	9514

$$\phi N_{ag} = \phi (A_{Na} / A_{Na0}) \psi_{ec,Na} \psi_{ed,Na} \psi_{cp,Na} N_{ba} \text{ (Sec. 17.3.1 \& Eq. 17.4.5.1b)}$$

A _{Na} (in ²)	A _{Na0} (in ²)	C _{Na} (in)	C _{a,min} (in)	ψ _{ec,Na}	ψ _{ed,Na}	ψ _{cp,Na}	N _{ba} (lb)	φ	φN _{ag} (lb)
198.45	112.09	5.29	7.25	1.000	1.000	1.000	9514	0.55	9265



Company:		Date:	5/14/2018
Engineer:		Page:	5/6
Project:			
Address:			
Phone:			
E-mail:			

8. Steel Strength of Anchor in Shear (Sec. 17.5.1)

V_{sa} (lb)	ϕ_{grout}	ϕ	$\phi_{grout}\phi V_{sa}$ (lb)
2715	1.0	0.65	1765

9. Concrete Breakout Strength of Anchor in Shear (Sec. 17.5.2)

Shear perpendicular to edge in x-direction:

$V_{bx} = \min|7(l_e / d_a)^{0.2} \sqrt{d_a} \lambda_a \sqrt{f_c} c_{a1}^{1.5}; 9 \lambda_a \sqrt{f_c} c_{a1}^{1.5}|$ (Eq. 17.5.2.2a & Eq. 17.5.2.2b)

l_e (in)	d_a (in)	λ_a	f_c (psi)	c_{a1} (in)	V_{bx} (lb)
3.00	0.375	1.00	2500	13.75	16564

$\phi V_{cbgx} = \phi (A_{vc} / A_{vco}) \psi_{ec,v} \psi_{ed,v} \psi_{c,v} \psi_{h,v} V_{bx}$ (Sec. 17.3.1 & Eq. 17.5.2.1b)

A_{vc} (in ²)	A_{vco} (in ²)	$\psi_{ec,v}$	$\psi_{ed,v}$	$\psi_{c,v}$	$\psi_{h,v}$	V_{bx} (lb)	ϕ	ϕV_{cbgx} (lb)
647.11	850.78	1.000	0.805	1.000	1.000	16564	0.70	7103

Shear perpendicular to edge in y-direction:

$V_{by} = \min|7(l_e / d_a)^{0.2} \sqrt{d_a} \lambda_a \sqrt{f_c} c_{a1}^{1.5}; 9 \lambda_a \sqrt{f_c} c_{a1}^{1.5}|$ (Eq. 17.5.2.2a & Eq. 17.5.2.2b)

l_e (in)	d_a (in)	λ_a	f_c (psi)	c_{a1} (in)	V_{by} (lb)
3.00	0.375	1.00	2500	10.75	11450

$\phi V_{cbgy} = \phi (A_{vc} / A_{vco}) \psi_{ec,v} \psi_{ed,v} \psi_{c,v} \psi_{h,v} V_{by}$ (Sec. 17.3.1 & Eq. 17.5.2.1b)

A_{vc} (in ²)	A_{vco} (in ²)	$\psi_{ec,v}$	$\psi_{ed,v}$	$\psi_{c,v}$	$\psi_{h,v}$	V_{by} (lb)	ϕ	ϕV_{cbgy} (lb)
387.00	520.03	1.000	0.891	1.000	1.000	11450	0.70	5313

Shear parallel to edge in x-direction:

$V_{by} = \min|7(l_e / d_a)^{0.2} \sqrt{d_a} \lambda_a \sqrt{f_c} c_{a1}^{1.5}; 9 \lambda_a \sqrt{f_c} c_{a1}^{1.5}|$ (Eq. 17.5.2.2a & Eq. 17.5.2.2b)

l_e (in)	d_a (in)	λ_a	f_c (psi)	c_{a1} (in)	V_{by} (lb)
3.00	0.375	1.00	2500	7.25	6342

$\phi V_{cbgx} = \phi (2)(A_{vc} / A_{vco}) \psi_{ec,v} \psi_{ed,v} \psi_{c,v} \psi_{h,v} V_{by}$ (Sec. 17.3.1, 17.5.2.1(c) & Eq. 17.5.2.1b)

A_{vc} (in ²)	A_{vco} (in ²)	$\psi_{ec,v}$	$\psi_{ed,v}$	$\psi_{c,v}$	$\psi_{h,v}$	V_{by} (lb)	ϕ	ϕV_{cbgx} (lb)
261.00	236.53	1.000	1.000	1.000	1.000	6342	0.70	9797

Shear parallel to edge in y-direction:

$V_{bx} = \min|7(l_e / d_a)^{0.2} \sqrt{d_a} \lambda_a \sqrt{f_c} c_{a1}^{1.5}; 9 \lambda_a \sqrt{f_c} c_{a1}^{1.5}|$ (Eq. 17.5.2.2a & Eq. 17.5.2.2b)

l_e (in)	d_a (in)	λ_a	f_c (psi)	c_{a1} (in)	V_{bx} (lb)
3.00	0.375	1.00	2500	10.25	10661

$\phi V_{cbgy} = \phi (2)(A_{vc} / A_{vco}) \psi_{ec,v} \psi_{ed,v} \psi_{c,v} \psi_{h,v} V_{bx}$ (Sec. 17.3.1, 17.5.2.1(c) & Eq. 17.5.2.1b)

A_{vc} (in ²)	A_{vco} (in ²)	$\psi_{ec,v}$	$\psi_{ed,v}$	$\psi_{c,v}$	$\psi_{h,v}$	V_{bx} (lb)	ϕ	ϕV_{cbgy} (lb)
401.67	472.78	1.000	1.000	1.000	1.000	10661	0.70	12680

10. Concrete Pryout Strength of Anchor in Shear (Sec. 17.5.3)

$\phi V_{cp} = \phi \min|k_{cp} N_{ag}; k_{cp} N_{cbg}| = \phi \min|k_{cp} (A_{Na} / A_{Na0}) \psi_{ec,Na} \psi_{ed,Na} \psi_{cp,Na} N_{ba}; k_{cp} (A_{Nc} / A_{Nco}) \psi_{ec,N} \psi_{ed,N} \psi_{c,N} \psi_{cp,N} N_b|$ (Sec. 17.3.1 & Eq. 17.5.3.1b)

k_{cp}	A_{Na} (in ²)	A_{Na0} (in ²)	$\psi_{ed,Na}$	$\psi_{ec,Na}$	$\psi_{cp,Na}$	N_{ba} (lb)	N_a (lb)
2.0	198.45	112.09	1.000	1.000	1.000	9514	16845

A_{Nc} (in ²)	A_{Nco} (in ²)	$\psi_{ec,N}$	$\psi_{ed,N}$	$\psi_{c,N}$	$\psi_{cp,N}$	N_b (lb)	N_{cb} (lb)	ϕ
424.63	324.00	1.000	0.942	1.000	1.000	12492	15417	0.70

Input data and results must be checked for agreement with the existing circumstances, the standards and guidelines must be checked for plausibility.



Company:		Date:	5/14/2018
Engineer:		Page:	6/6
Project:			
Address:			
Phone:			
E-mail:			

ϕV_{cpq} (lb)
21584

11. Results

Interaction of Tensile and Shear Forces (Sec. R17.6)

Tension	Factored Load, N_{ua} (lb)	Design Strength, ϕN_n (lb)	Ratio	Status	
Steel	968	3394	0.29	Pass	
Concrete breakout	3870	10021	0.39	Pass	
Adhesive	3870	9265	0.42	Pass (Governs)	
Shear	Factored Load, V_{ua} (lb)	Design Strength, ϕV_n (lb)	Ratio	Status	
Steel	706	1765	0.40	Pass	
T Concrete breakout x+	175	7103	0.02	Pass	
T Concrete breakout y-	2820	5313	0.53	Pass	
Concrete breakout y-	88	9797	0.01	Pass	
Concrete breakout x-	1410	12680	0.11	Pass	
Concrete breakout, combined	-	-	0.53	Pass (Governs)	
Pryout	2825	21584	0.13	Pass	
Interaction check	$(N_{ua}/\phi N_{ua})^{5/3}$	$(V_{ua}/\phi V_{ua})^{5/3}$	Combined Ratio	Permissible	Status
Sec. R17.6	0.23	0.35	58.2%	1.0	Pass

SET-3G w/ 3/8"Ø F1554 Gr. 36 with hef = 6.000 inch meets the selected design criteria.

12. Warnings

- Designer must exercise own judgement to determine if this design is suitable.
- Refer to manufacturer's product literature for hole cleaning and installation instructions.



JOB NO.: U2716-070-181

DESIGNED: STB

PROJECT: Ground Mount Package for Ontario Canada

Framing Analysis

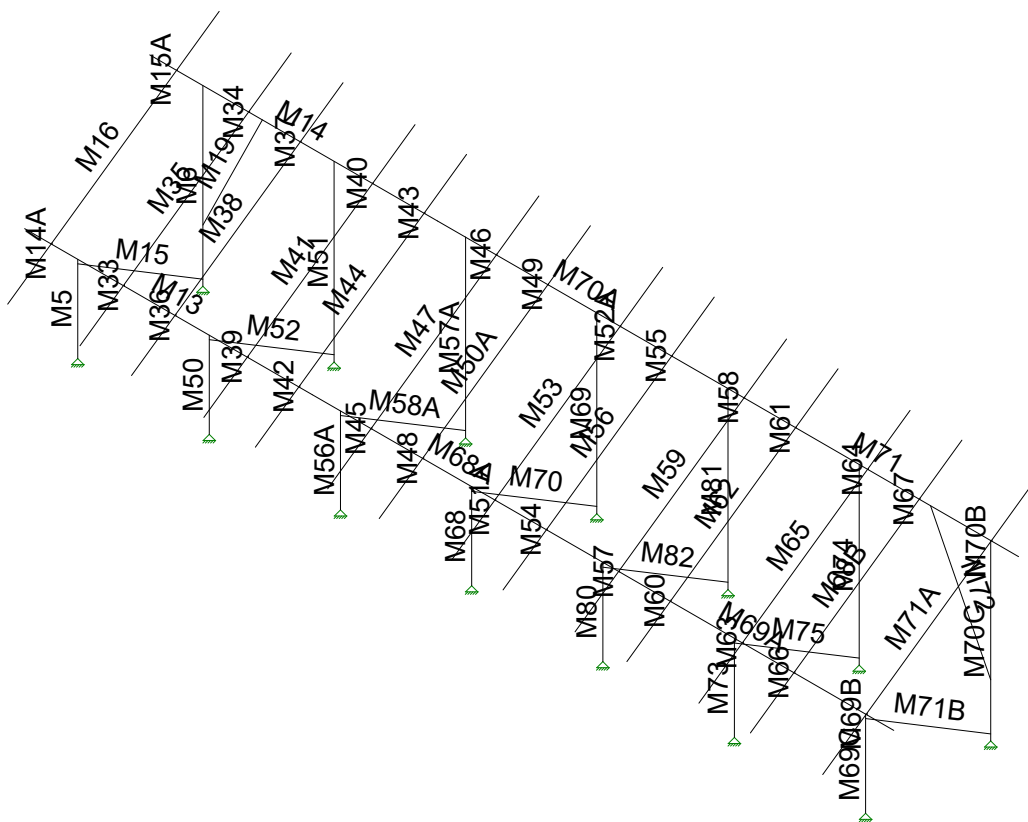

Vector Structural Engineeri...	Ground Mount	SK - 5
STB		Aug 1, 2019 at 12:15 PM
U2716.114.191		New England A5.r3d

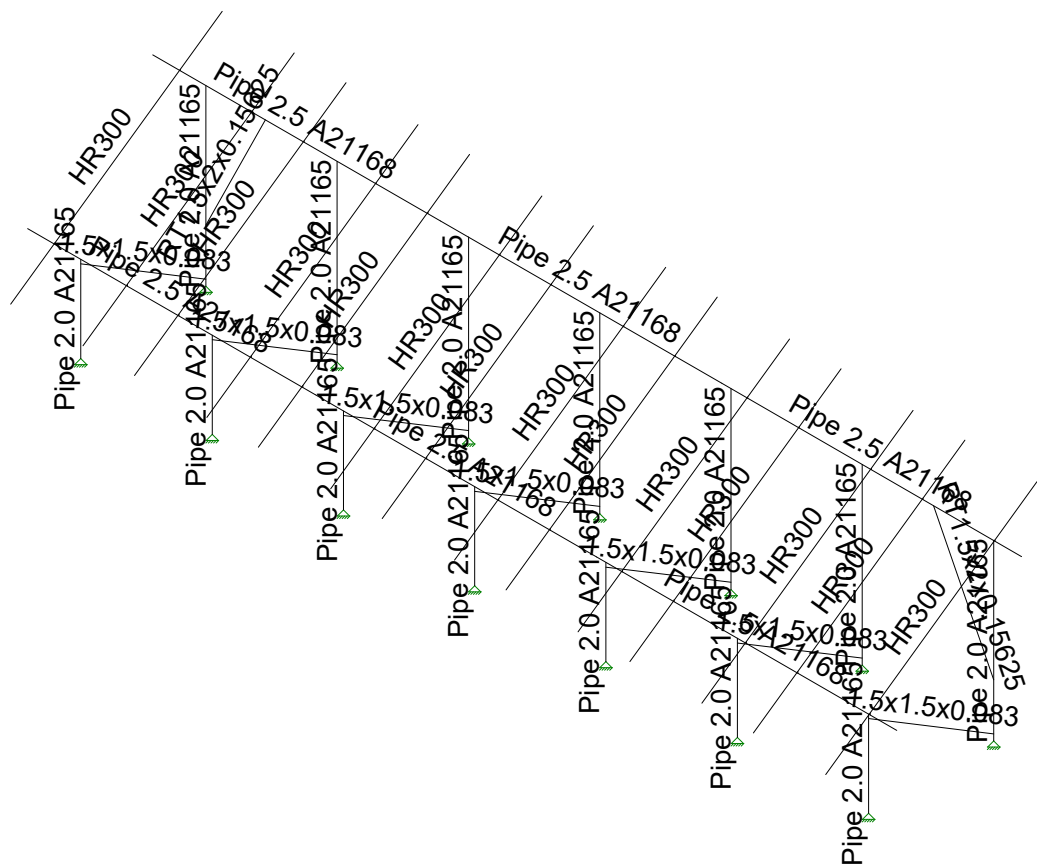

Vector Structural Engineeri...
STB
U2716.114.191

Ground Mount

SK - 6
Aug 1, 2019 at 12:15 PM
New England A5.r3d

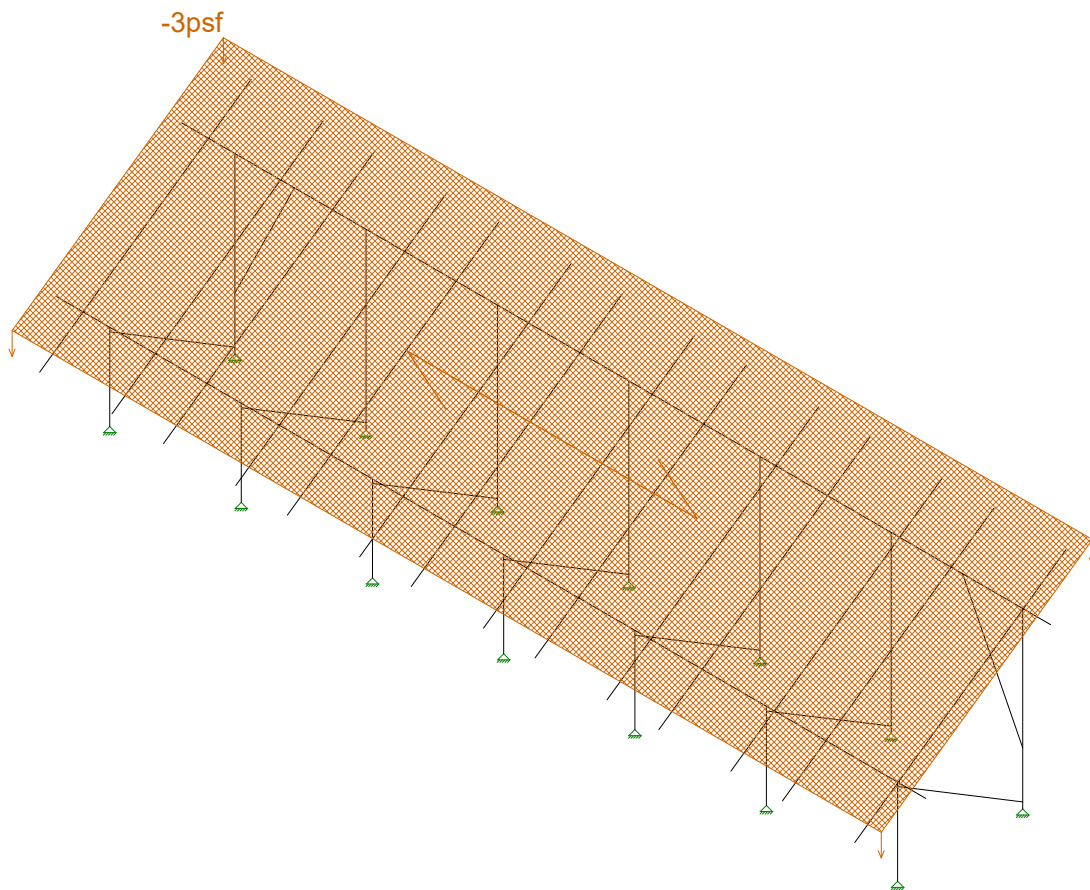

Loads: BLC 2, Solar Panel Weight

Vector Structural Engineeri..	Ground Mount	SK - 7
STB		Aug 1, 2019 at 12:15 PM
U2716.114.191		New England A5.r3d

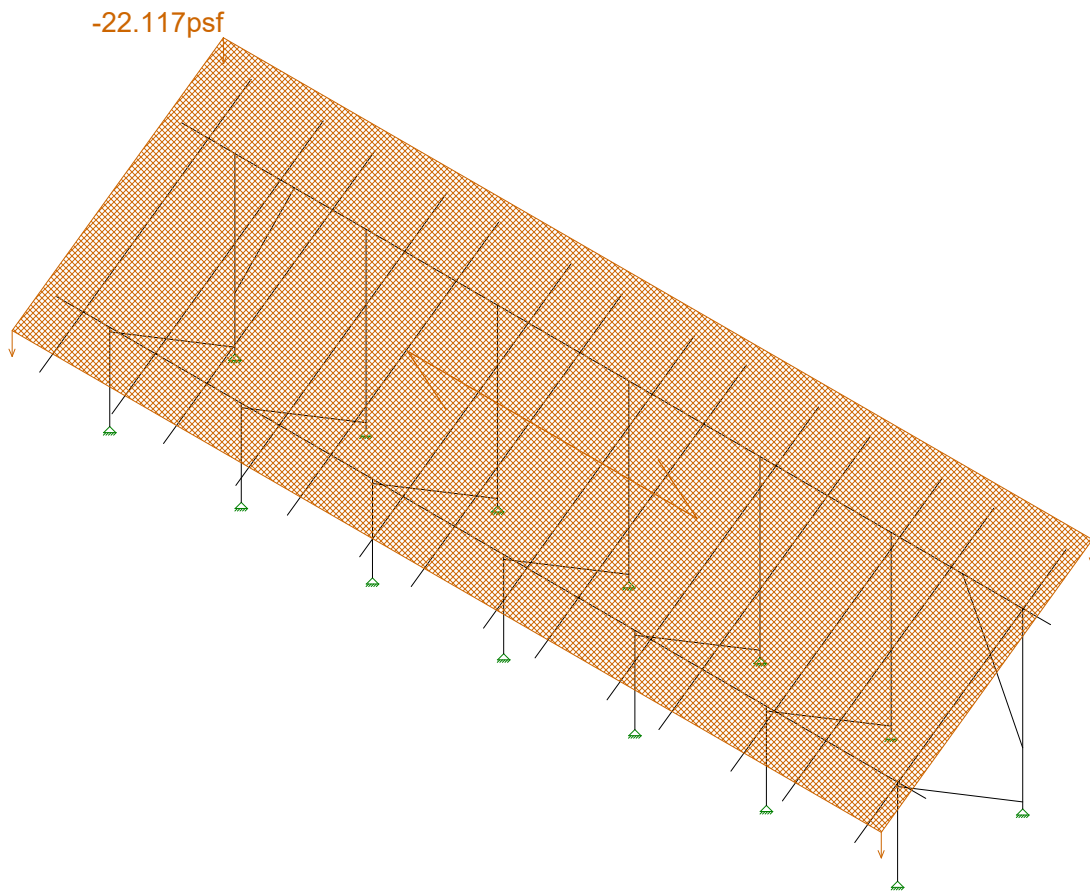

Loads: BLC 3, Roof Live/Snow

Vector Structural Engineeri..	Ground Mount	SK - 8
STB		Aug 1, 2019 at 12:15 PM
U2716.114.191		New England A5.r3d

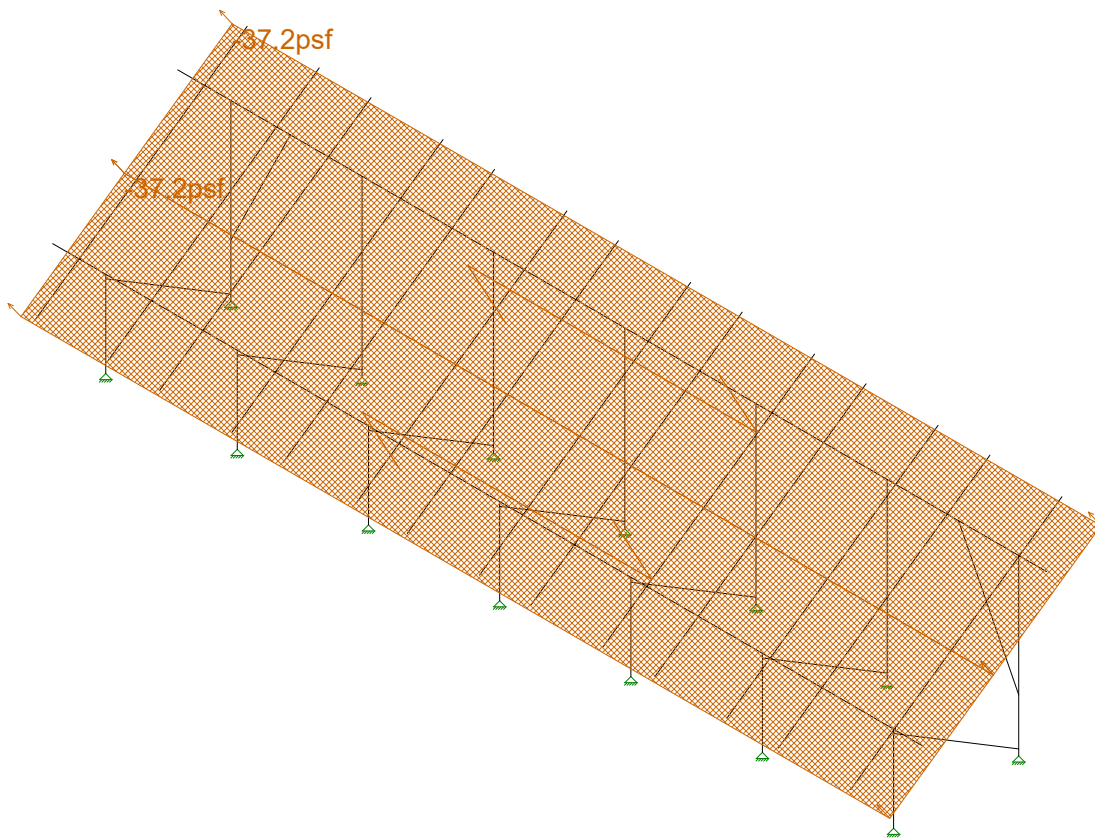

Loads: BLC 4, Wind A 0 deg

Vector Structural Engineeri..

STB

U2716.114.191

Ground Mount

SK - 9

Aug 1, 2019 at 12:15 PM

New England A5.r3d

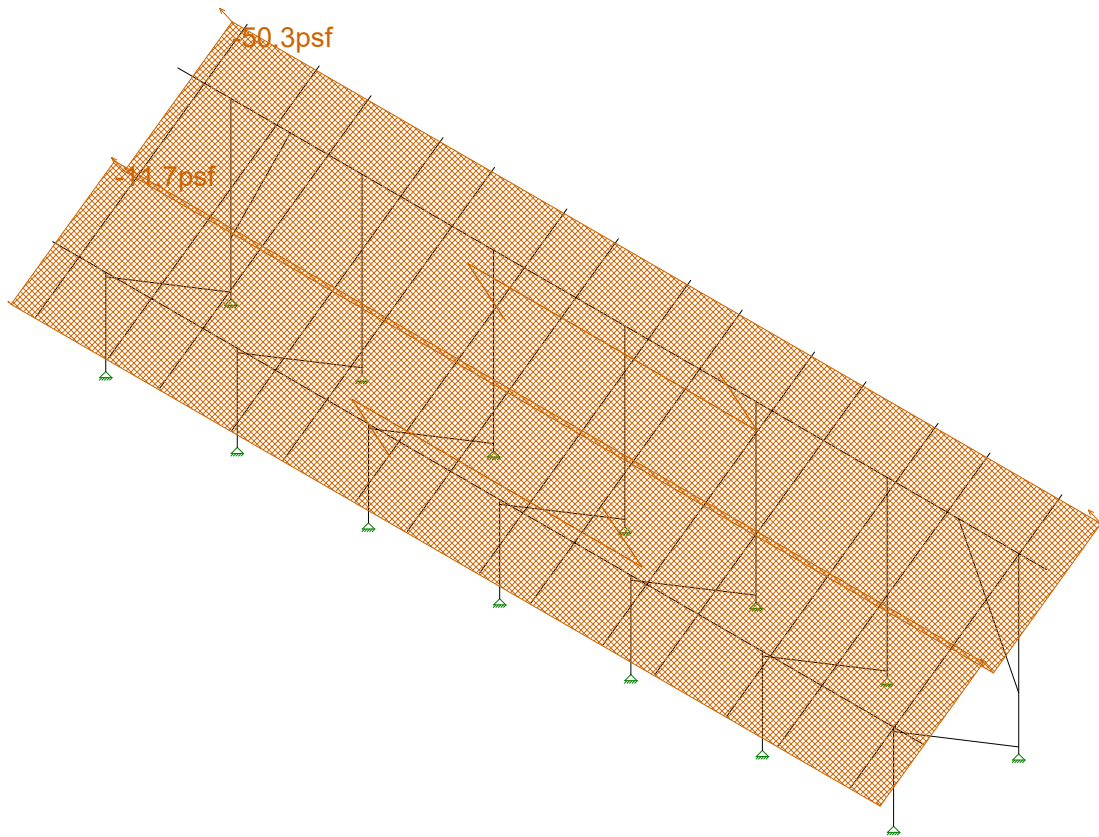

Loads: BLC 5, Wind B 0 deg

Vector Structural Engineeri..

STB

U2716.114.191

Ground Mount

SK - 10

Aug 1, 2019 at 12:16 PM

New England A5.r3d

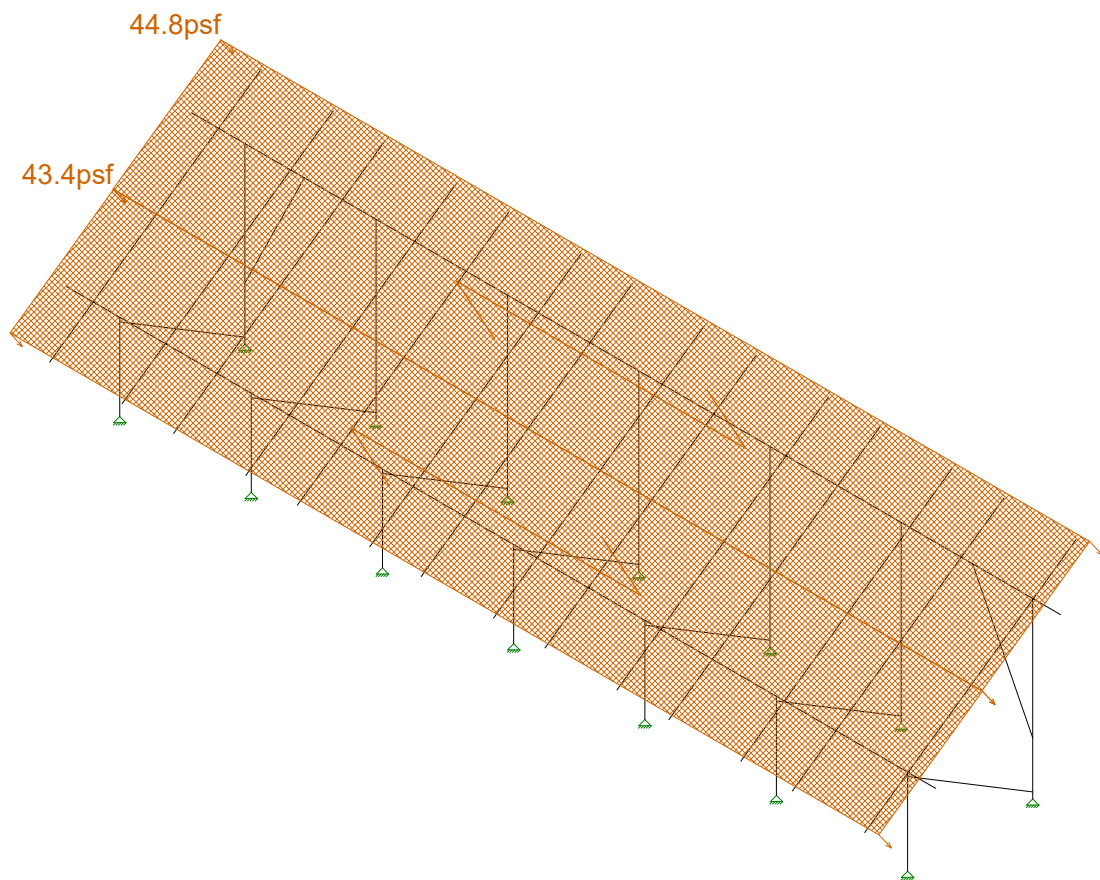

Loads: BLC 6, Wind A 180 deg

Vector Structural Engineeri..	Ground Mount	SK - 11
STB		Aug 1, 2019 at 12:16 PM
U2716.114.191		New England A5.r3d

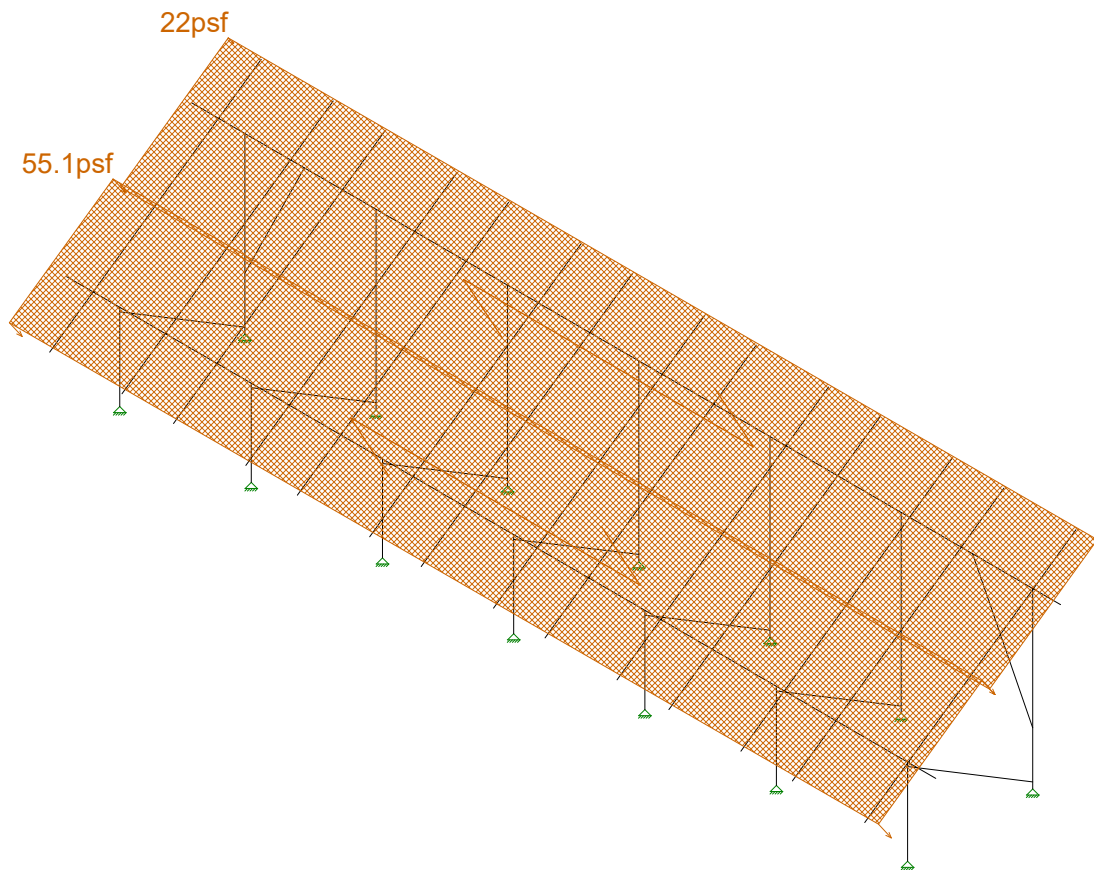

Loads: BLC 7, Wind B 180 deg

Vector Structural Engineeri..

STB

U2716.114.191

Ground Mount

SK - 12

Aug 1, 2019 at 12:16 PM

New England A5.r3d

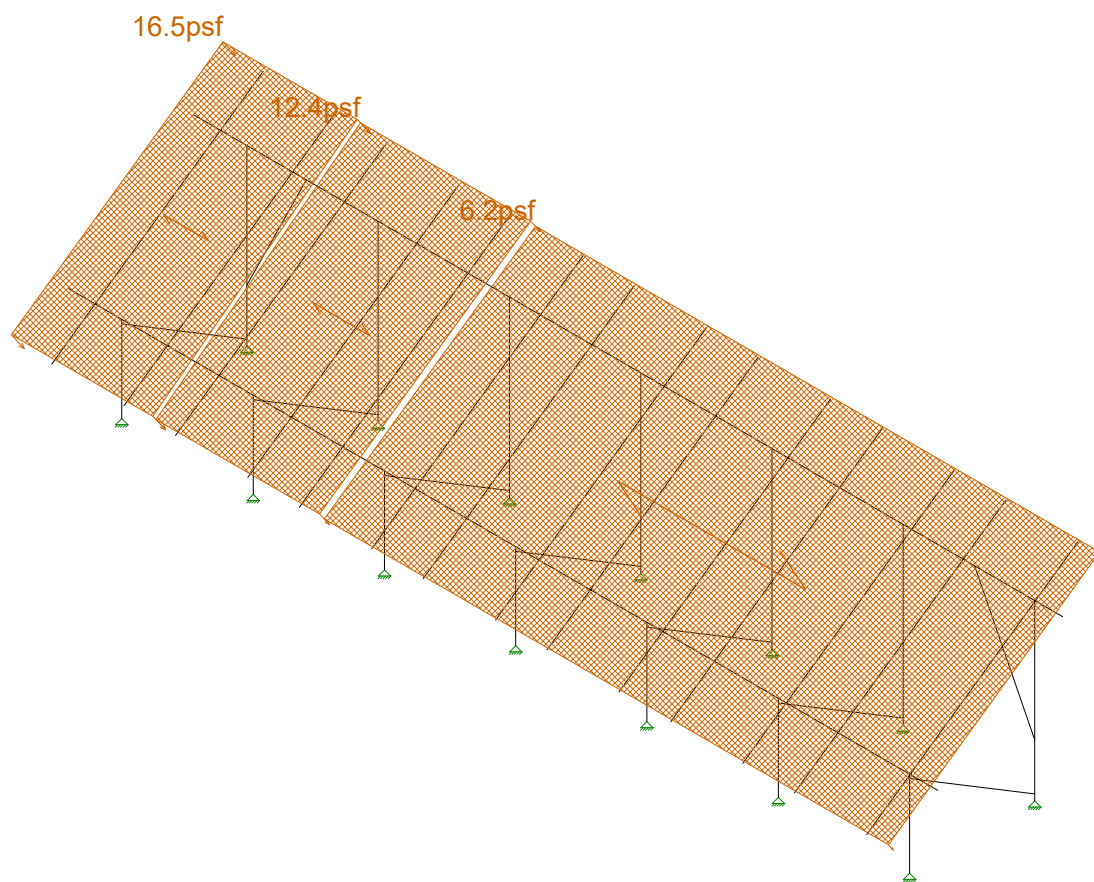

Loads: BLC 8, Wind A 90

Vector Structural Engineeri..	Ground Mount	SK - 13
STB		Aug 1, 2019 at 12:16 PM
U2716.114.191		New England A5.r3d

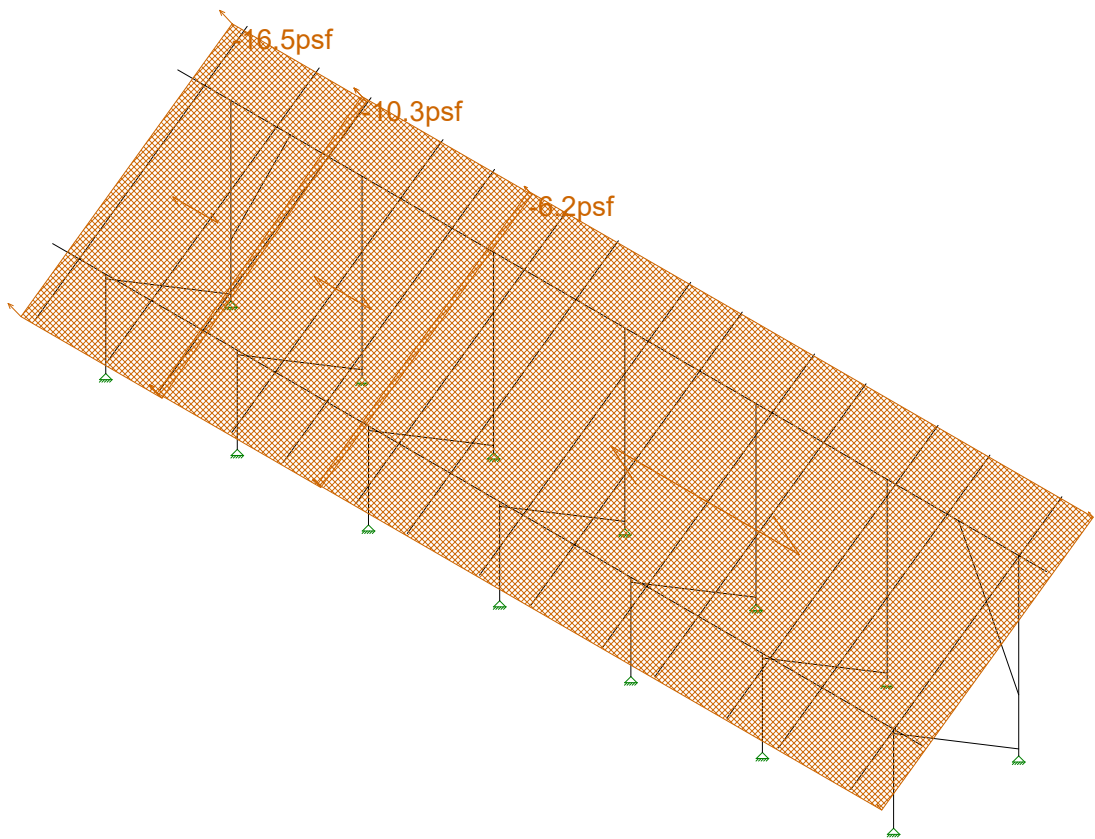

Loads: BLC 9, Wind B 90

Vector Structural Engineeri..	Ground Mount	SK - 14
STB		Aug 1, 2019 at 12:16 PM
U2716.114.191		New England A5.r3d



Code Check (Elem)	
Black	No Calc
Red	> 1.0
Yellow	40-1.0
Green	75-90
Cyan	50-75
Blue	0-.50

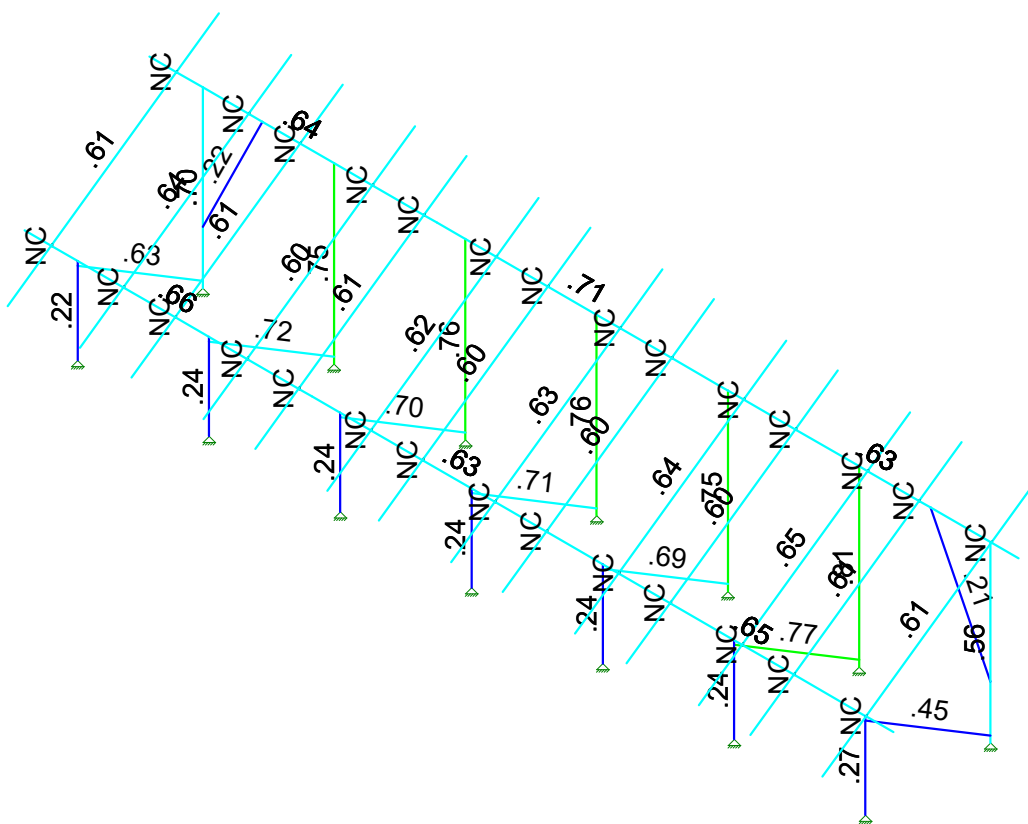

Member Code Checks Displayed (Enveloped)
Envelope Only Solution

Vector Structural Engineeri...	Ground Mount	SK - 3
STB		Aug 1, 2019 at 12:15 PM
U2716.114.191		New England A5.r3d

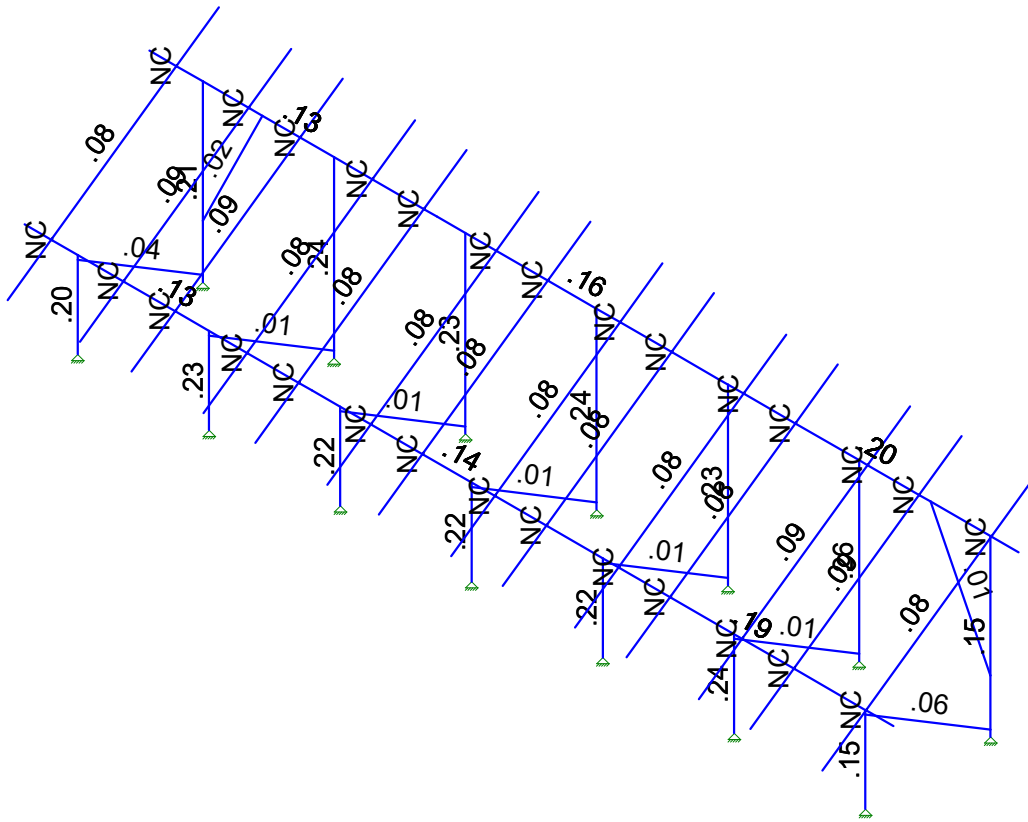

Member Shear Checks Displayed (Enveloped)
Envelope Only Solution

Vector Structural Engineeri...	Ground Mount	SK - 4
STB		Aug 1, 2019 at 12:15 PM
U2716.114.191		New England A5.r3d



(Global) Model Settings

Display Sections for Member Calcs	5
Max Internal Sections for Member Calcs	97
Include Shear Deformation?	Yes
Increase Nailing Capacity for Wind?	Yes
Include Warping?	Yes
Trans Load Btwn Intersecting Wood Wall?	Yes
Area Load Mesh (in^2)	144
Merge Tolerance (in)	.12
P-Delta Analysis Tolerance	0.50%
Include P-Delta for Walls?	Yes
Automatically Iterate Stiffness for Walls?	Yes
Max Iterations for Wall Stiffness	3
Gravity Acceleration (in/sec^2)	386.4
Wall Mesh Size (in)	24
Eigensolution Convergence Tol. (1.E-)	4
Vertical Axis	Y
Global Member Orientation Plane	XZ
Static Solver	Sparse Accelerated
Dynamic Solver	Accelerated Solver

Hot Rolled Steel Code	AISC 14th(360-10): ASD
Adjust Stiffness?	Yes(Iterative)
RISACONNECTION Code	AISC 14th(360-10): ASD
Cold Formed Steel Code	AISI S100-16: ASD
Wood Code	AWC NDS-15: ASD
Wood Temperature	< 100F
Concrete Code	ACI 318-14
Masonry Code	ACI 530-13: ASD
Aluminum Code	AA ADM1-15: ASD - Building AISC 14th(360-10): ASD

Number of Shear Regions	4
Region Spacing Increment (in)	4
Biaxial Column Method	Exact Integration
Parame Beta Factor (PCA)	.65
Concrete Stress Block	Rectangular
Use Cracked Sections?	Yes
Use Cracked Sections Slab?	No
Bad Framing Warnings?	No
Unused Force Warnings?	Yes
Min 1 Bar Diam. Spacing?	No
Concrete Rebar Set	REBAR SET ASTMA615
Min % Steel for Column	1
Max % Steel for Column	8



(Global) Model Settings, Continued

Seismic Code	ASCE 7-10
Seismic Base Elevation (in)	15600
Add Base Weight?	Yes
Ct X	.02
Ct Z	.02
T X (sec)	Not Entered
T Z (sec)	Not Entered
R X	3
R Z	3
Ct Exp. X	.75
Ct Exp. Z	.75
SD1	1
SDS	1
S1	1
TL (sec)	5
Risk Cat	I or II
Drift Cat	Other
Om Z	1
Om X	1
Cd Z	4
Cd X	4
Rho Z	1
Rho X	1

Hot Rolled Steel Properties

	Label	E [ksi]	G [ksi]	Nu	Therm (1E5 F)	Density[lb/ft^3]	Yield[psi]	Ry	Fu[psi]	Rt
1	A992	29000	11154	.3	.65	490	50000	1.1	65000	1.1
2	A36 Gr.36	29000	11154	.3	.65	490	36000	1.5	58000	1.2
3	A572 Gr.50	29000	11154	.3	.65	490	50000	1.1	65000	1.1
4	A500 Gr.B R...	29000	11154	.3	.65	527	42000	1.4	58000	1.3
5	A500 Gr.B Re...	29000	11154	.3	.65	527	46000	1.4	58000	1.3
6	A53 Gr.B	29000	11154	.3	.65	490	35000	1.6	60000	1.2
7	A1085	29000	11154	.3	.65	490	50000	1.4	65000	1.3

Aluminum Properties

	Label	E [ksi]	G [ksi]	Nu	Therm (...Density[... Table B.4	kt	Ftu[psi]	Fty[psi]	Fcy[psi]	Fsu[psi]	Ct
1	3003-H14	10100	3787.5	.33	1.3 172.8 Table B.4-1	1	19000	16000	13000	12000	141
2	6061-T6	10100	3787.5	.33	1.3 172.8 Table B.4-2	1	38000	35000	35000	24000	141
3	6063-T5	10100	3787.5	.33	1.3 172.8 Table B.4-2	1	22000	16000	16000	13000	141
4	6063-T6	10100	3787.5	.33	1.3 172.8 Table B.4-2	1	30000	25000	25000	19000	141
5	5052-H34	10200	3787.5	.33	1.3 172.8 Table B.4-1	1	34000	26000	24000	20000	141
6	6061-T6 W	10100	3787.5	.33	1.3 172.8 Table B.4-1	1	24000	15000	15000	15000	141
7	6005-T5	10100	3787.5	.33	1.3 172.8 Table B.4-1	1	38000	35000	35000	24000	141

Hot Rolled Steel Section Sets

	Label	Shape	Type	Design List	Material	Design R...	A [in2]	Iyy [in4]	Izz [in4]	J [in4]
1	Post	Pipe 2.0 A21165	Column	Pipe	A572 Gr.50	Typical	.776	.499	.499	.998
2	Cross Beam	Pipe 2.5 A21168	Beam	Wide Flange	A572 Gr.50	Typical	.947	.907	.907	1.814
3	Diagonal Brace	1.5x1.5x0.083	HBrace	SquareTube	A572 Gr.50	Typical	.47	.158	.158	.236



Company : Vector Structural Engineering
 Designer : STB
 Job Number : U2716.114.191
 Model Name : Ground Mount

Aug 1, 2019
 12:16 PM
 Checked By: _____

Aluminum Section Sets

	Label	Shape	Type	Design List	Material	Design R...	A [in2]	Iyy [in4]	Izz [in4]	J [in4]
1	AL Posts	2.375ODX0.188	Column	Pipe	6005-T5	Typical	1.29	.778	.778	1.54
2	AL Brace	RT1.5x2x0.15625	VBrace	Rectangular Tubes	6005-T5	Typical	.996	.327	.524	.602
3	AL Rails	HR300	Beam	Rectangular Tubes	6005-T5	Typical	.736	.214	.727	.614
4	AL Cross Beam	Cross Rail	Beam	Rectangular Tubes	6005-T5	Typical	1.909	1.97	4.366	4.017

Member Area Loads (BLC 2 : Solar Panel Weight)

	Joint A	Joint B	Joint C	Joint D	Direction	Distribution	Magnitude[psf]
1	N197	N200	N199	N196	Y	A-B	-3

Member Area Loads (BLC 3 : Roof Live/Snow)

	Joint A	Joint B	Joint C	Joint D	Direction	Distribution	Magnitude[psf]
1	N197	N200	N199	N196	PY	A-B	-27

Member Area Loads (BLC 4 : Wind A 0 deg)

	Joint A	Joint B	Joint C	Joint D	Direction	Distribution	Magnitude[psf]
1	N197	N200	N201	N198	Perp	A-B	-37.2
2	N198	N201	N199	N196	Perp	A-B	-37.2

Member Area Loads (BLC 5 : Wind B 0 deg)

	Joint A	Joint B	Joint C	Joint D	Direction	Distribution	Magnitude[psf]
1	N197	N200	N201	N198	Perp	A-B	-50.3
2	N198	N201	N199	N196	Perp	A-B	-11.7

Member Area Loads (BLC 6 : Wind A 180 deg)

	Joint A	Joint B	Joint C	Joint D	Direction	Distribution	Magnitude[psf]
1	N197	N200	N201	N198	Perp	A-B	44.8
2	N198	N201	N199	N196	Perp	A-B	43.4

Member Area Loads (BLC 7 : Wind B 180 deg)

	Joint A	Joint B	Joint C	Joint D	Direction	Distribution	Magnitude[psf]
1	N197	N200	N201	N198	Perp	A-B	22
2	N198	N201	N199	N196	Perp	A-B	55.1

Member Area Loads (BLC 8 : Wind A 90)

	Joint A	Joint B	Joint C	Joint D	Direction	Distribution	Magnitude[psf]
1	N197	N203	N202	N196	Perp	A-B	16.5
2	N203	N209	N208	N202	Perp	A-B	12.4
3	N209	N200	N199	N208	Perp	A-B	6.2

Member Area Loads (BLC 9 : Wind B 90)

	Joint A	Joint B	Joint C	Joint D	Direction	Distribution	Magnitude[psf]
1	N197	N203	N202	N196	Perp	A-B	-16.5
2	N203	N209	N208	N202	Perp	A-B	-10.3
3	N209	N200	N199	N208	Perp	A-B	-6.2

Basic Load Cases

	BLC Description	Category	X Gravity	Y Gravity	Z Gravity	Joint	Point	Distributed	Area(M...Surface...
1	Self Weight	DL		-1.05					
2	Solar Panel Weight	DL							1



Company : Vector Structural Engineering
 Designer : STB
 Job Number : U2716.114.191
 Model Name : Ground Mount

Aug 1, 2019
 12:16 PM
 Checked By: _____

Basic Load Cases (Continued)

	BLC Description	Category	X Gravity	Y Gravity	Z Gravity	Joint	Point	Distributed	Area(M... Surface...
3	Roof Live/Snow	RLL							1
4	Wind A 0 deg	OL1							2
5	Wind B 0 deg	OL2							2
6	Wind A 180 deg	OL3							2
7	Wind B 180 deg	OL4							2
8	Wind A 90	OL5							3
9	Wind B 90	OL6							3
10	BLC 2 Transient Area ...	None						34	
11	BLC 3 Transient Area ...	None						34	
12	BLC 4 Transient Area ...	None						120	
13	BLC 5 Transient Area ...	None						120	
14	BLC 6 Transient Area ...	None						120	
15	BLC 7 Transient Area ...	None						120	
16	BLC 8 Transient Area ...	None						98	
17	BLC 9 Transient Area ...	None						98	

Load Combinations

	Description	S...	PD...	SRSS	BLC Fa...	BLC Fa...	BLC Fa...	B...Fa...	B...Fa...	B...Fa...	B...Fa...	B...Fa...	B...Fa...	B...Fa...	B...Fa...
1	1.0 D	Yes	Y		DL 1										
2	1.0 D + 1.0 S	Yes	Y		DL 1	RLL 1									
3	1.0 D + 0.6 W1	Yes	Y		DL 1	RLL OL1 .6									
4	1.0 D + 0.6 W2	Yes	Y		DL 1	RLL OL2 .6									
5	1.0 D + 0.6 W3	Yes	Y		DL 1	RLL OL3 .6									
6	1.0 D + 0.6 W4	Yes	Y		DL 1	RLL OL4 .6									
7	1.0 D + 0.6 W5	Yes	Y		DL 1	RLL OL5 .6									
8	1.0 D + 0.6 W6	Yes	Y		DL 1	RLL OL6 .6									
9	1.0 D + 0.45 W1 + 0....	Yes	Y		DL 1	RLL .75 OL1 .45									
10	1.0 D + 0.45 W2 + 0....	Yes	Y		DL 1	RLL .75 OL2 .45									
11	1.0 D + 0.45 W3 + 0....	Yes	Y		DL 1	RLL .75 OL3 .45									
12	1.0 D + 0.45 W4 + 0....	Yes	Y		DL 1	RLL .75 OL4 .45									
13	1.0 D + 0.45 W5 + 0....	Yes	Y		DL 1	RLL .75 OL5 .45									
14	1.0 D + 0.45 W6 + 0....	Yes	Y		DL 1	RLL .75 OL6 .45									
15	0.6 D + 0.6 W1	Yes	Y		DL .6	RLL OL1 .6									
16	0.6 D + 0.6 W2	Yes	Y		DL .6	RLL OL2 .6									
17	0.6 D + 0.6 W3	Yes	Y		DL .6	RLL OL3 .6									
18	0.6 D + 0.6 W4	Yes	Y		DL .6	RLL OL4 .6									
19	0.6 D + 0.6 W5	Yes	Y		DL .6	RLL OL5 .6									
20	0.6 D + 0.6 W6	Yes	Y		DL .6	RLL OL6 .6									

Envelope Joint Reactions

	Joint	X [lb]	LC	Y [lb]	LC	Z [lb]	LC	MX [lb-ft]	LC	MY [lb-ft]	LC	MZ [lb-ft]	LC
1	N2	max	11.449	6	1496.227	10	58.446	3	0	1	0	1	0
2		min	-7.151	15	-324.739	17	-67.668	5	0	1	0	1	0
3	N1	max	116.121	11	2791.857	11	1358.6...	5	0	1	0	1	0
4		min	-90.026	16	-2122.991	16	-1147....	3	0	1	0	1	0
5	N132	max	3.579	11	2908.171	11	1506.6...	5	0	1	0	1	0
6		min	-2.295	16	-2244.555	16	-1271....	3	0	1	0	1	0
7	N133	max	8.939	12	1670.582	10	62.776	3	0	1	0	1	0
8		min	-.462	15	-354.382	17	-73.022	5	0	1	0	1	0
9	N109	max	3.499	14	2791.753	11	1574.4...	5	0	1	0	1	0
10		min	-1.578	16	-2148.809	16	-1327....	3	0	1	0	1	0
11	N110A	max	4.552	5	1742.038	10	62.784	3	0	1	0	1	0
12		min	-8.126	4	-391.178	17	-73.136	5	0	1	0	1	0
13	N121	max	1.689	8	2949.279	11	1523.7...	5	0	1	0	1	0

Envelope Joint Reactions (Continued)

Joint	X [lb]	LC	Y [lb]	LC	Z [lb]	LC	MX [lb-ft]	LC	MY [lb-ft]	LC	MZ [lb-ft]	LC		
14	min	-1.945	19	-2274.407	16	-1287....	3	0	1	0	1	0	1	
15	N122	max	6.224	12	1691.671	10	63.102	3	0	1	0	1	0	1
16		min	-2.134	15	-360.177	17	-73.406	5	0	1	0	1	0	1
17	N133B	max	2.83	11	2928.261	11	1541.6...	5	0	1	0	1	0	1
18		min	-1.434	16	-2254.273	16	-1301....	3	0	1	0	1	0	1
19	N134B	max	10.193	12	1703.544	10	63.326	3	0	1	0	1	0	1
20		min	-1.721	15	-368.186	17	-73.542	5	0	1	0	1	0	1
21	N151	max	4.182	11	3013.072	11	1688.9...	5	0	1	0	1	0	1
22		min	-1.188	16	-2319.265	16	-1426....	3	0	1	0	1	0	1
23	N152	max	30.297	12	1845.542	10	62.377	3	0	1	0	1	0	1
24		min	-8.747	15	-437.714	17	-71.617	5	0	1	0	1	0	1
25	N143A	max	98.799	16	2049.985	11	968.025	5	0	1	0	1	0	1
26		min	-130.723	11	-1545.653	16	-816.164	3	0	1	0	1	0	1
27	N144A	max	23.184	15	1076.12	10	47.422	3	0	1	0	1	0	1
28		min	-64.678	12	-210.858	17	-55.787	5	0	1	0	1	0	1
29	Totals:	max	.02	19	23712.94	11	9673.9...	5						
30		min	-.04	14	-9980.616	15	-8157....	15						

Envelope AISC 14th(360-10): ASD Steel Code Checks

Member	Shape	Code Check	Loc[in]	LC	Shear	...	Loc[in]	Dir	LC	Pnc/om	[..Pnt/om	[lb]	Mnyy/om...	Mnzz/om...	Cb	Eqn
1	M5	Pipe 2.0 A2...	.222	52.073	17	.201	52.645	5	16486.797	23232.186	1397.505	1397.505	1...	H1-1b		
2	M6	Pipe 2.0 A2...	.703	3.477	5	.210	0	5	6062.107	23232.186	1397.505	1397.505	1...	H1-1a		
3	M13	Pipe 2.5 A2...	.656	118....	12	.128	116....	12	11641.036	28358.413	2081.747	2081.747	2...	H1-1b		
4	M14	Pipe 2.5 A2...	.639	118....	11	.127	116....	11	11641.036	28358.413	2081.747	2081.747	2...	H1-1b		
5	M15	1.5x1.5x0.083	.626	48.694	5	.039	0	y	11	2716.455	14085.15	624.421	624.421	1...	H1-1a	
6	M80	Pipe 2.0 A2...	.237	52.073	17	.217	52.645	5	16486.797	23232.186	1397.505	1397.505	1...	H1-1b		
7	M81	Pipe 2.0 A2...	.752	3.477	5	.230	0	5	6062.107	23232.186	1397.505	1397.505	1...	H1-1a		
8	M82	1.5x1.5x0.083	.691	48.694	5	.010	93.493	y	10	2716.455	14085.15	624.421	624.421	1...	H1-1a	
9	M50	Pipe 2.0 A2...	.239	52.073	17	.227	52.645	5	16486.797	23232.186	1397.505	1397.505	1...	H1-1b		
10	M51	Pipe 2.0 A2...	.754	3.477	5	.241	0	5	6062.107	23232.186	1397.505	1397.505	1...	H1-1a		
11	M52	1.5x1.5x0.083	.722	48.694	5	.007	0	y	14	2716.455	14085.15	624.421	624.421	1...	H1-1a	
12	M56A	Pipe 2.0 A2...	.239	52.073	17	.220	52.645	5	16486.797	23232.186	1397.505	1397.505	1...	H1-1b		
13	M57A	Pipe 2.0 A2...	.762	3.477	5	.234	0	5	6062.107	23232.186	1397.505	1397.505	2...	H1-1a		
14	M58A	1.5x1.5x0.083	.699	48.694	5	.007	0	y	4	2716.455	14085.15	624.421	624.421	1...	H1-1a	
15	M68	Pipe 2.0 A2...	.239	52.073	17	.222	52.645	5	16486.797	23232.186	1397.505	1397.505	1...	H1-1b		
16	M69	Pipe 2.0 A2...	.763	3.477	5	.236	0	5	6062.107	23232.186	1397.505	1397.505	1...	H1-1a		
17	M70	1.5x1.5x0.083	.707	48.694	5	.009	0	y	10	2716.455	14085.15	624.421	624.421	1...	H1-1a	
18	M68A	Pipe 2.5 A2...	.635	18.75	12	.138	103....	12	11641.036	28358.413	2081.747	2081.747	2...	H1-1b		
19	M69A	Pipe 2.5 A2...	.652	90	12	.193	90	12	11641.036	28358.413	2081.747	2081.747	1...	H1-1b		
20	M70A	Pipe 2.5 A2...	.707	18.75	11	.161	103....	11	11641.036	28358.413	2081.747	2081.747	2...	H1-1b		
21	M71	Pipe 2.5 A2...	.632	6	11	.196	90	11	11641.036	28358.413	2081.747	2081.747	2...	H1-1b		
22	M73	Pipe 2.0 A2...	.240	52.073	17	.245	52.645	5	16486.797	23232.186	1397.505	1397.505	1...	H1-1b		
23	M74	Pipe 2.0 A2...	.811	3.477	5	.258	0	5	6062.107	23232.186	1397.505	1397.505	1...	H1-1a		
24	M75	1.5x1.5x0.083	.774	48.694	5	.011	93.493	y	10	2716.455	14085.15	624.421	624.421	1...	H1-1a	
25	M69C	Pipe 2.0 A2...	.274	52.645	12	.146	52.645	5	16486.797	23232.186	1397.505	1397.505	1...	H1-1b		
26	M70C	Pipe 2.0 A2...	.561	33.608	11	.147	0	5	6062.107	23232.186	1397.505	1397.505	1...	H1-1a		
27	M71B	1.5x1.5x0.083	.448	48.694	5	.063	93.493	y	11	2716.455	14085.15	624.421	624.421	1...	H1-1a	

Envelope AA ADM1-15: ASD - Building Aluminum Code Checks

Member	Shape	Code C...	Loc[in]	LC	Shear	...	Loc[in]	Dir	LC	Pnc/O...	Pnt/Om...	Mny/O...	Mnz/O...	Vny/O...	Vnz/O...	Cb	Eqn
1	M19	RT1.5x2x...	.222	52.977	11	.022	0	z	5	2260.001	19411....	770.742	927.083	6090.199	4101.563	1...	H.1-1
2	M16	HR300	.615	82.515	11	.082	36.1	y	11	3887.213	14342....	494.953	934.619	6236.364	2843.273	1	H.1-1
3	M35	HR300	.635	80.796	11	.092	36.1	y	12	3887.213	14342....	494.953	934.619	6236.364	2843.273	1	H.1-1
4	M38	HR300	.615	84.234	11	.086	36.1	y	12	3887.213	14342....	494.953	934.619	6236.364	2843.273	1	H.1-1



Company : Vector Structural Engineering
 Designer : STB
 Job Number : U2716.114.191
 Model Name : Ground Mount

Aug 1, 2019
 12:16 PM
 Checked By: _____

Envelope AA ADM1-15: ASD - Building Aluminum Code Checks (Continued)

Member	Shape	Code C...	Loc[in]	LC	Shear ...	Loc[in]	Dir	LC	Pnc/O...	Pnt/Om...	Mny/O...	Mnz/O...	Vny/O...	Vnz/O...	Cb	Eqn
5	M41	HR300	.604	84.234	11	.082	36.1	y	12	3887.213	14342....	494.953	934.619	6236.364	2843.273	1 H.1-1
6	M44	HR300	.606	84.234	11	.081	36.1	y	12	3887.213	14342....	494.953	934.619	6236.364	2843.273	1 H.1-1
7	M47	HR300	.619	84.234	11	.082	36.1	y	12	3887.213	14342....	494.953	934.619	6236.364	2843.273	1 H.1-1
8	M50A	HR300	.597	34.381	12	.082	36.1	y	12	3887.213	14342....	494.953	934.619	6236.364	2843.273	1 H.1-1
9	M53	HR300	.630	84.234	11	.082	36.1	y	12	3887.213	14342....	494.953	934.619	6236.364	2843.273	1 H.1-1
10	M56	HR300	.597	34.381	12	.081	36.1	y	12	3887.213	14342....	494.953	934.619	6236.364	2843.273	1 H.1-1
11	M59	HR300	.638	84.234	11	.081	36.1	y	12	3887.213	14342....	494.953	934.619	6236.364	2843.273	1 H.1-1
12	M62	HR300	.597	34.381	12	.081	36.1	y	12	3887.213	14342....	494.953	934.619	6236.364	2843.273	1 H.1-1
13	M65	HR300	.646	84.234	11	.086	36.1	y	12	3887.213	14342....	494.953	934.619	6236.364	2843.273	1 H.1-1
14	M68B	HR300	.611	80.796	11	.091	36.1	y	12	3887.213	14342....	494.953	934.619	6236.364	2843.273	1 H.1-1
15	M71A	HR300	.607	84.234	11	.080	36.1	y	12	3887.213	14342....	494.953	934.619	6236.364	2843.273	1 H.1-1
16	M72	RT1.5x2x...	.208	53.045	11	.012	0	z	5	2254.199	19411....	770.742	927.083	6090.199	4101.563	1...H.1-1

NOTES: UNLESS OTHERWISE SPECIFIED
 1. DIMENSIONS SHOWN ARE INCHES [MILIMETERS].

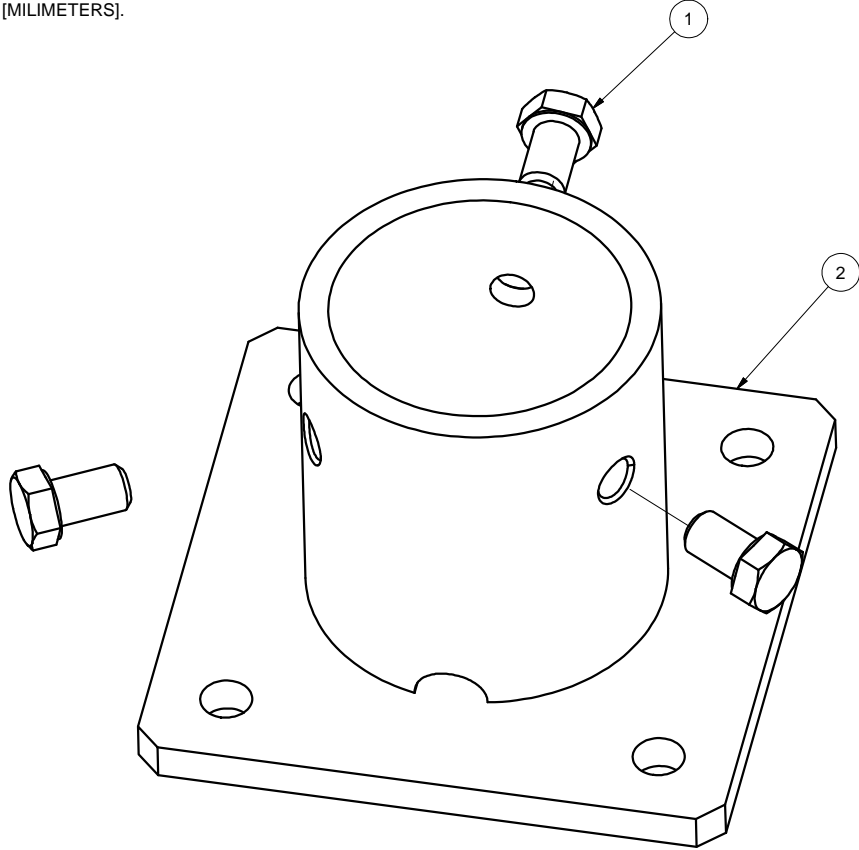

REVISIONS			
REV	DESCRIPTION	BY	DATE
A	INITIAL RELEASE	LWF	10/20/2016

2	A21120-001	2" PIPE BASE	1
1	B15018-011	HEX CAP SCREW 3/8-16 X 5/8	3
ITEM	PART NUMBER	DESCRIPTION	QTY
MATERIAL		Sunmodo Corp. 1905 E 5TH STREET, STE A, VANCOUVER, WA 98661	
SEE NOTES			
Third Angle Projection:		TITLE	
GENERAL SPECIFICATIONS All Dimensions in inches [millimeters] Tolerances X.XXX ±0.01 [0.25mm] X.XX ±0.02 [0.50mm] X.X ±0.039 [1.0mm] Unless otherwise spec'd		2" PIPE BASE KIT	
DRAWN BY	DATE	DRAWING NUMBER	
LWF	10/20/2016	B K10268-001	
CHECKED BY		SCALE: NONE SHEET 1 of 1	
APPROVALS			

THIS DRAWING IS CONFIDENTIAL PROPERTY OF SUNMODO AND ITS CONTENTS MAY NOT BE DISCLOSED WITHOUT THE PRIOR WRITTEN CONSENT OF SUNMODO CORP.

NOTES: UNLESS OTHERWISE SPECIFIED

1. DIMENSIONS SHOWN ARE INCHES [MILIMETERS].
2. MATERIAL: ALUMINUM 6005-T5.
FINISH: CLEAR ANODIZED 10 μ m THICK.
3. THE UNSPECIFIED DIMENSIONS ARE SPECIFIED BY 2D CAD FILE.

Section properties:

Weight: 1.156 lbs/ft

Area: 0.992 in²

Perimeter: 12.601 in

Bounding Box: X: -1.000,1.000

Y: -0.750, 0.750

Centroid:(0.000,0.000)

Moments of Inertia(in⁴): Ix=0.506,Iy=0.322

Section modulus in bending(in³): Wx=0.675,Wy=0.322

Radii of Gyration: X: 0.714, Y: 0.570

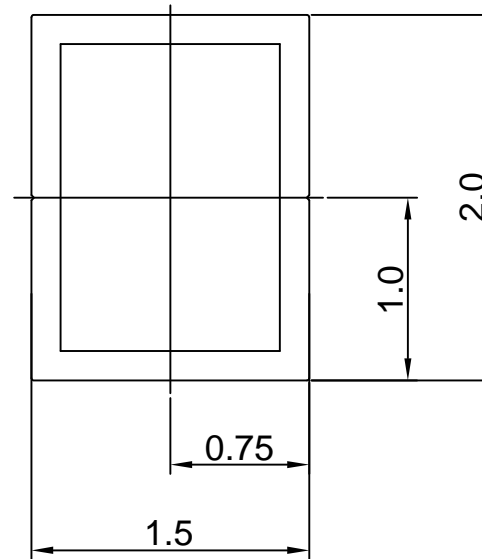

MATERIAL		SEE NOTES	
Third Angle Projection:		Sunmodo Corp. 1905 E 5TH STREET, SUITE A, VANCOUVER, WA 98661	
GENERAL SPECIFICATIONS All Dimensions in inches [millimeters]			
Tolerances		TITLE	
X.XXX ± 0.01 [0.25mm]		1.5X2 AL TUBE BRACE EXTRUSION	
X.XX ± 0.02 [0.50mm]		DRAWING NUMBER	
X.X ± 0.039 [1.0mm]		B A20164	
Unless otherwise specified.		SCALE: NONE	
DRAWN BY		DATE	
zcg		03/12/2014	
CHECKED BY		APPROVALS	
		SHEET 1 of 1	

REVISIONS			
REV	DESCRIPTION	BY	DATE
A	ADDED BOTTOM CHANNEL & CHANGED ONE 3/8 CHANNEL TO 1/4	zcg	02/21/2013

NOTES: UNLESS OTHERWISE SPECIFIED

1. DIMENSIONS SHOWN ARE INCHES [MILIMETERS].
2. MATERAIL: ALUMINUM 6005-T5.
FINISH: CLEAR ANODIZED 15 μ m THICK.
3. THE UNSPECIFIED DIMENSIONS ARE SPECIFIED BY 2D CAD FILE.

2X 1/4 BOLT SLOT

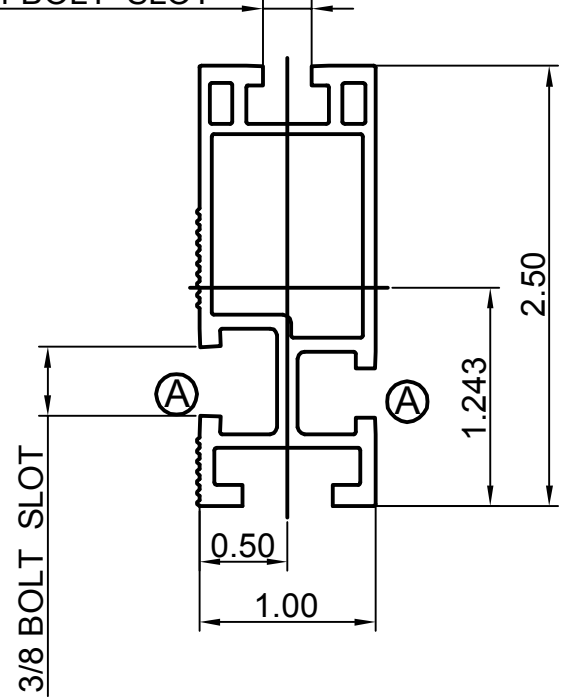

Section properties:

Weight: 0.850 lbs/ft
 Area: 0.723 in²
 Perimeter: 17.325 in
 Bounding Box: X: -0.500,0.500
 Y: -1.243,1.257

Centroid:(0.000,0.000)
 Moments of Inertia(in⁴): Ix=0.486,Iy=0.095
 Section modulus in bending(in³): Wx=0.387,Wy=0.190
 Radii of Gyration: X: 0.820, Y: 0.363

MATERIAL SEE NOTES		Sunmodo Corp.	
Third Angle Projection:			
GENERAL SPECIFICATIONS All Dimensions in inches [millimeters]		1905 E 5TH STREET, SUITE A, VANCOUVER, WA 98661	
Tolerances: X.XXX ± 0.01 [0.25mm] X.XX ± 0.02 [0.50mm] X.X ± 0.039 [1.0mm] Unless otherwise spec'd		TITLE HELIO STANDARD RAIL	
DRAWN BY zcg	DATE 02/21/2013	DRAWING NUMBER A20144	
CHECKED BY		SCALE: NONE SHEET 1 of 1	
APPROVALS			

NOTES: UNLESS OTHERWISE SPECIFIED

1. DIMENSIONS SHOWN ARE INCHES [MILIMETERS].
2. MATERIAL: 6005-T5.
FINISH: CLEAR ANODIZED 10um THICK.
3. THE UNSPECIFIED RADII ARE .02" MAX.
4. THE UNSPECIFIED DIMENSIONS ARE SPECIFIED BY 2D CAD FILE.

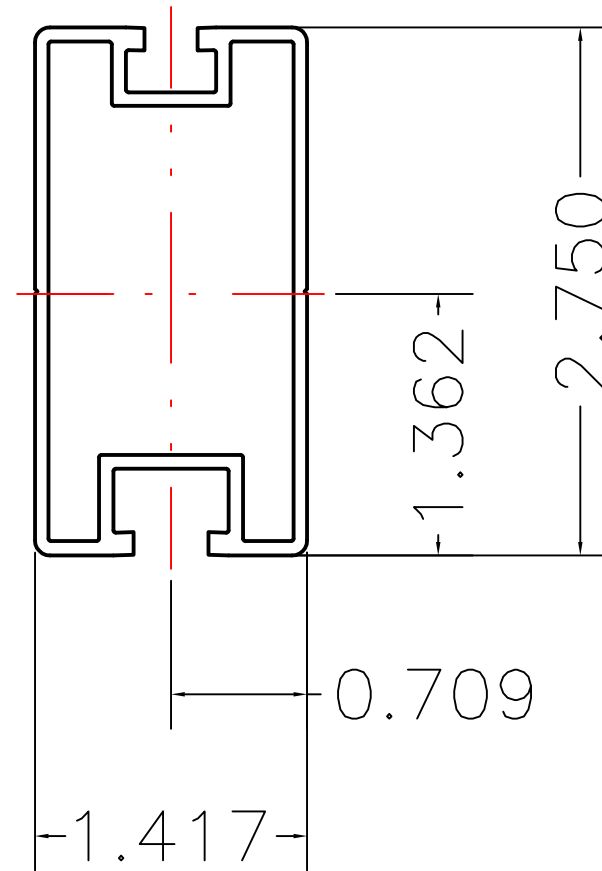

Section properties:

Weight: 0.862 lbs/ft
 Area: 0.736 in²
 Perimeter: 19.824 in
 Bounding Box: X: -0.709,0.709
 Y: -1.362,1.388
 Centroid:(0.000,0.000)
 Moments of Inertia(in⁴): I_x=0.727,I_y=0.214
 Section modulus in bending(in³): W_x=0.524,W_y=0.302
 Radii of Gyration: X: 994, Y: 0.539

THIS DRAWING IS CONFIDENTIAL PROPERTY OF SUNMODO AND ITS CONTENTS MAY NOT BE DISCLOSED WITHOUT THE PRIOR WRITTEN CONSENT OF SUNMODO CORP.

MATERIAL SEE NOTES		SunModo Corp. 14800 NE 65TH STREET, VANCOUVER WA 98682	
Third Angle Projection:			
GENERAL SPECIFICATIONS All Dimensions in inches [millimeters]		TITLE RAIL, HR300 (SUNRAY), EXTRUSION	
Tolerances X.XXX ±0.01 [0.25mm] X.XX ±0.02 [0.50mm] Break all sharp edges X.X ±0.039 [1.0mm] .010-.020 unless otherwise specified. Unless otherwise spec'd			
DRAWN BY KYY	DATE 01/18/2018	B	DRAWING NUMBER A20288
CHECKED BY			
APPROVALS		SCALE: NONE	SHEET 1 of 1

REV	DESCRIPTON	BY	DATE
A	0.44 WAS 0.41, 0.44 WAS 0.33	LWF	11/30/2015

NOTES: UNLESS OTHERWISE SPECIFIED

- 1. DIMENSIONS SHOWN ARE INCHES [MILIMETERS].
- 2. MATERIAL: ALUMINUM 6005-T5.
FINISH: CLEAR ANODIZED 15 μm THICK.
- 3. THE UNSPECIFIED DIMENSIONS ARE SPECIFIED BY 2D CAD FILE.

2X 1/4 BOLT SLOT

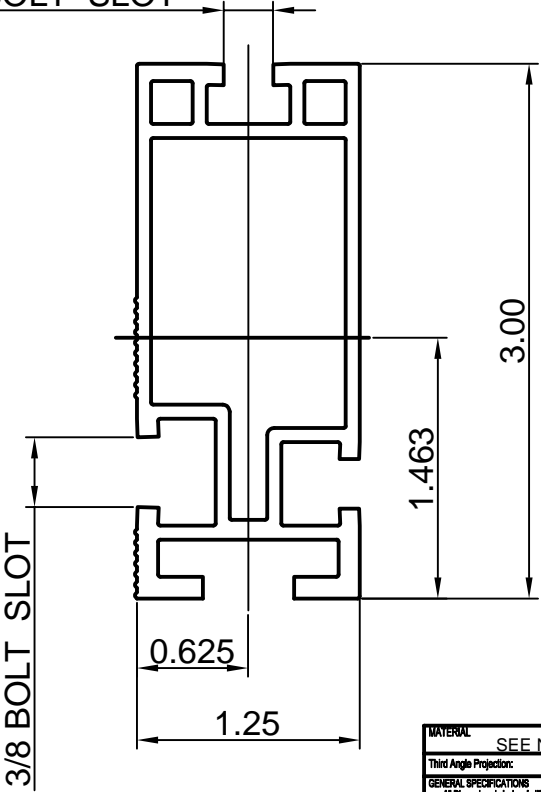

Section properties:

Weight: 1.151 lbs/ft
 Area: 0.980 in²
 Perimeter: 22.104 in
 Bounding Box: X: -0.625,0.625
 Y: -1.463,1.537
 Centroid:(0.000,0.000)
 Moments of Inertia(in⁴): Ix=1.047,Iy=0.207
 Section modulus in bending(in³): Wx=0.681,Wy=0.331
 Radii of Gyration: X: 1.034, Y: 0.460

MATERIAL		SEE NOTES	
Third Angle Projection			
GENERAL SPECIFICATIONS			
All Dimensions in Inches [millimeters]			
Tolerances			
XXXX ±0.01 (0.25mm)			
XX ±0.02 (0.50mm)			
X ±0.03 (1.0mm)			
Unless otherwise noted			
Break all sharp edges 0.10-0.25 unless otherwise specified.			
DRAWN BY		DATE	
ZCJ		02/21/2013	
CHECKED BY		B	
APPROVALS		DRAWING NUMBER	
		A20145	
SCALE:		SHEET	
NONE		1 of 1	

Sunmodo Corp.

1905 E 5TH STREET, SUITE A, VANCOUVER, WA 98661

TITLE
HELIO HEAVY RAIL

B DRAWING NUMBER
A20145

SCALE: NONE SHEET 1 of 1

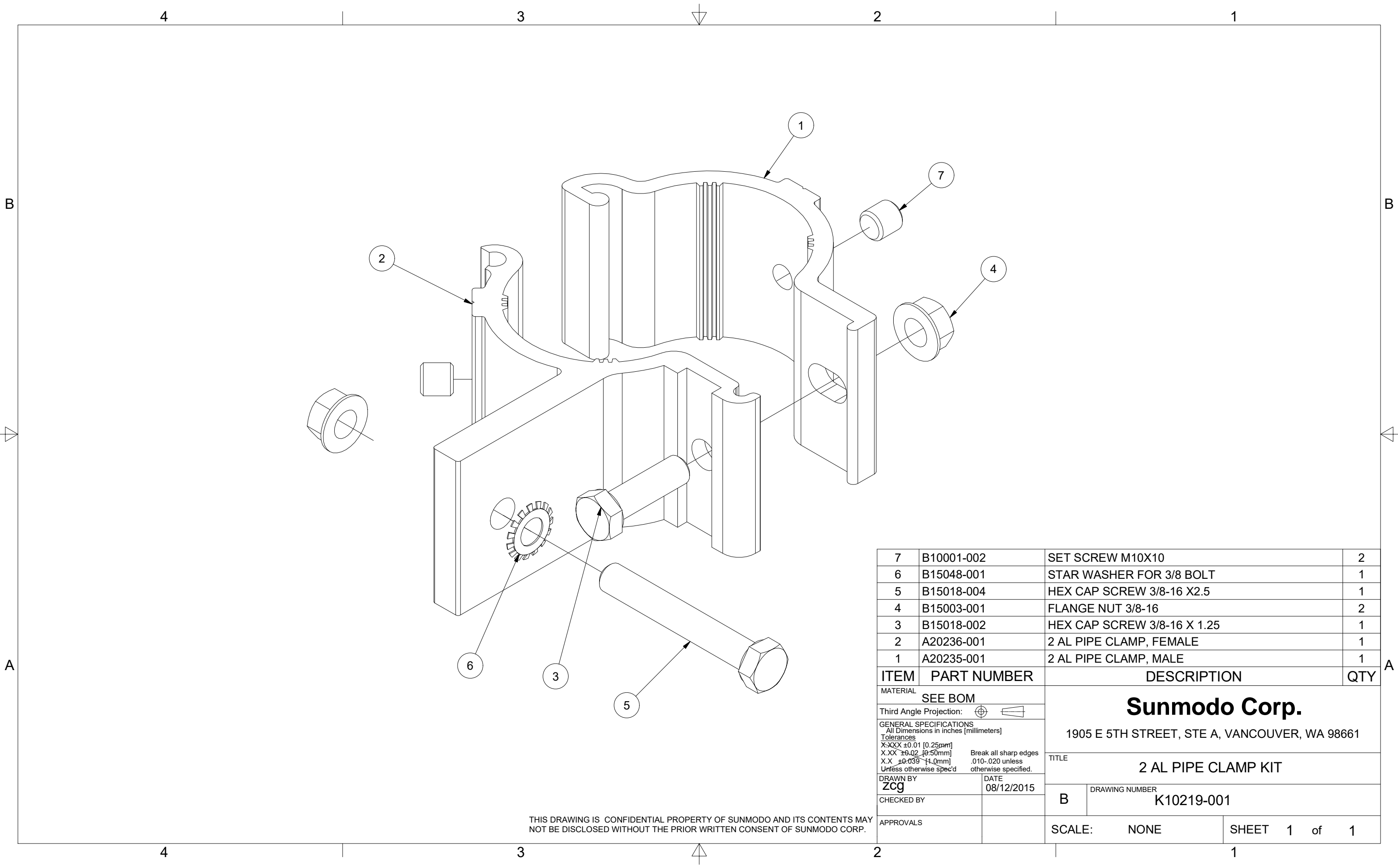

7	B10001-002	SET SCREW M10X10	2
6	B15048-001	STAR WASHER FOR 3/8 BOLT	1
5	B15018-004	HEX CAP SCREW 3/8-16 X2.5	1
4	B15003-001	FLANGE NUT 3/8-16	2
3	B15018-002	HEX CAP SCREW 3/8-16 X 1.25	1
2	A20236-001	2 AL PIPE CLAMP, FEMALE	1
1	A20235-001	2 AL PIPE CLAMP, MALE	1

ITEM	PART NUMBER	DESCRIPTION	QTY
MATERIAL		SEE BOM	
Third Angle Projection:			
GENERAL SPECIFICATIONS All Dimensions in inches (millimeters)			
Tolerances			
X.XXX ±0.01 [0.25mm]		Break all sharp edges	
X.XX ±0.02 [0.50mm]		.010-.020 unless	
X.X ±0.039 [1.0mm]		otherwise specified.	
DRAWN BY		DATE	
zcg		08/12/2015	
CHECKED BY		B	
APPROVALS		DRAWING NUMBER	
		K10219-001	
SCALE:		NONE	SHEET 1 of 1

Sunmodo Corp.
1905 E 5TH STREET, STE A, VANCOUVER, WA 98661

TITLE
2 AL PIPE CLAMP KIT

THIS DRAWING IS CONFIDENTIAL PROPERTY OF SUNMODO AND ITS CONTENTS MAY NOT BE DISCLOSED WITHOUT THE PRIOR WRITTEN CONSENT OF SUNMODO CORP.

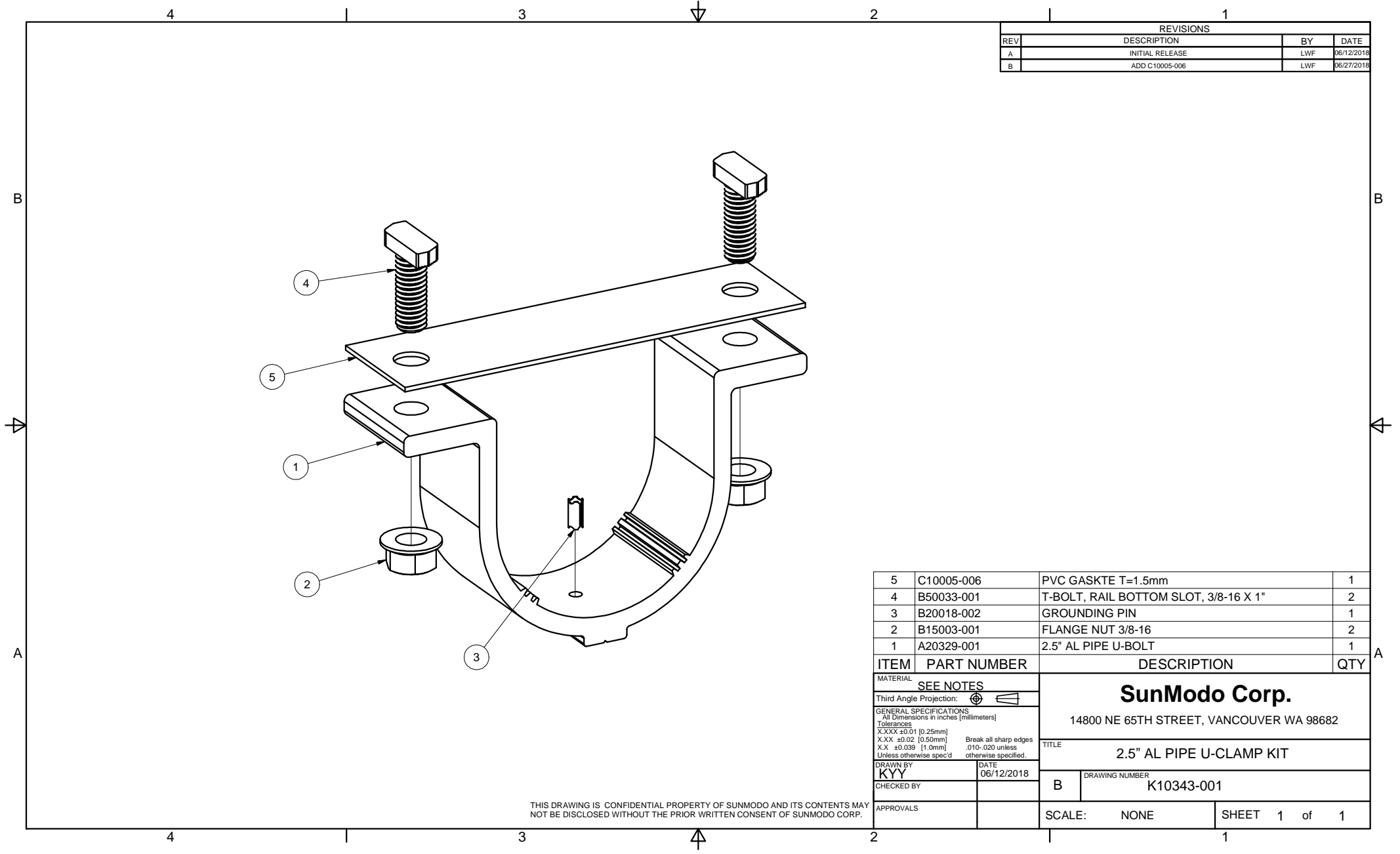

REVISIONS			
REV	DESCRIPTION	BY	DATE
A	INITIAL RELEASE	LWF	06/12/2018
B	ADD C10005-006	LWF	06/27/2018

ITEM	PART NUMBER	DESCRIPTION	QTY
5	C10005-006	PVC GASKTE T=1.5mm	1
4	B50033-001	T-BOLT, RAIL BOTTOM SLOT, 3/8-16 X 1"	2
3	B20018-002	GROUNDING PIN	1
2	B15003-001	FLANGE NUT 3/8-16	2
1	A20329-001	2.5" AL PIPE U-BOLT	1

MATERIAL		SEE NOTES	
Third Angle Projection:			
GENERAL SPECIFICATIONS		SunModo Corp. 14800 NE 65TH STREET, VANCOUVER WA 98682	
Tolerances		TITLE	
X.XXX ±0.01 [0.25mm] X.XX ±0.02 [0.50mm] X.X ±0.039 [1.0mm] Unless otherwise spec'd		2.5" AL PIPE U-CLAMP KIT	
DRAWN BY	DATE	DRAWING NUMBER	
KYY	06/12/2018	B K10343-001	
CHECKED BY		SCALE: NONE SHEET 1 of 1	
APPROVALS			

THIS DRAWING IS CONFIDENTIAL PROPERTY OF SUNMODO AND ITS CONTENTS MAY NOT BE DISCLOSED WITHOUT THE PRIOR WRITTEN CONSENT OF SUNMODO CORP.

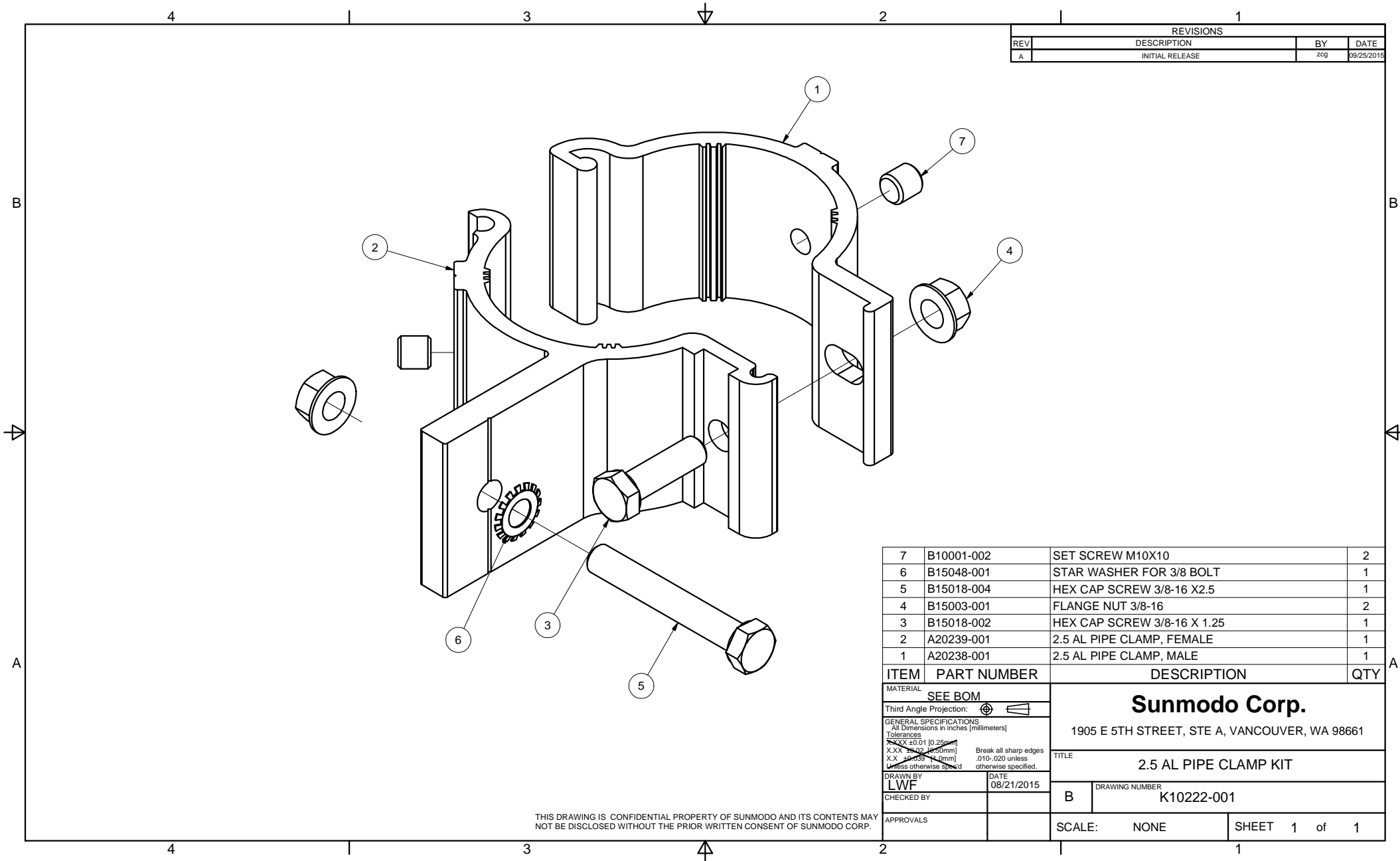

REVISIONS			
REV	DESCRIPTION	BY	DATE
A	INITIAL RELEASE	zcg	09/25/2015

ITEM	PART NUMBER	DESCRIPTION	QTY
7	B10001-002	SET SCREW M10X10	2
6	B15048-001	STAR WASHER FOR 3/8 BOLT	1
5	B15018-004	HEX CAP SCREW 3/8-16 X2.5	1
4	B15003-001	FLANGE NUT 3/8-16	2
3	B15018-002	HEX CAP SCREW 3/8-16 X 1.25	1
2	A20239-001	2.5 AL PIPE CLAMP, FEMALE	1
1	A20238-001	2.5 AL PIPE CLAMP, MALE	1

MATERIAL		SEE BOM	
Third Angle Projection:			
GENERAL SPECIFICATIONS All Dimensions in inches [millimeters] Tolerances X.XX ±0.01 [0.25mm] X.X ±0.02 [0.5mm] X.X ±0.03 [0.75mm] Unless otherwise specified.			
DRAWN BY		DATE	
LWF		08/21/2015	
CHECKED BY		B	
APPROVALS		SCALE: NONE	
		SHEET 1 of 1	

Sunmodo Corp.
 1905 E 5TH STREET, STE A, VANCOUVER, WA 98661

TITLE: **2.5 AL PIPE CLAMP KIT**

DRAWING NUMBER: **K10222-001**

THIS DRAWING IS CONFIDENTIAL PROPERTY OF SUNMODO AND ITS CONTENTS MAY NOT BE DISCLOSED WITHOUT THE PRIOR WRITTEN CONSENT OF SUNMODO CORP.

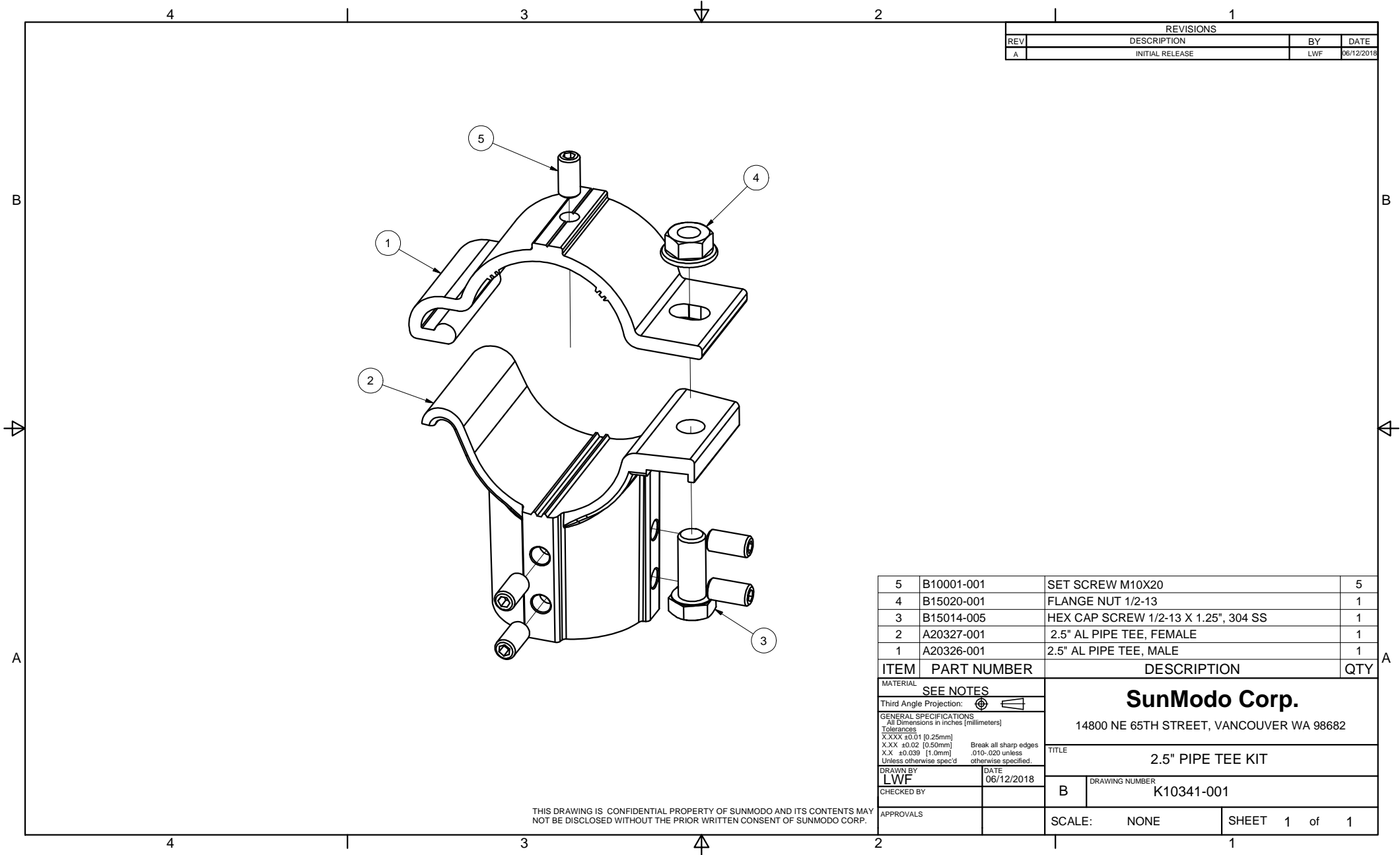

REVISIONS			
REV	DESCRIPTION	BY	DATE
A	INITIAL RELEASE	LWF	06/12/2018

ITEM	PART NUMBER	DESCRIPTION	QTY
5	B10001-001	SET SCREW M10X20	5
4	B15020-001	FLANGE NUT 1/2-13	1
3	B15014-005	HEX CAP SCREW 1/2-13 X 1.25", 304 SS	1
2	A20327-001	2.5" AL PIPE TEE, FEMALE	1
1	A20326-001	2.5" AL PIPE TEE, MALE	1

MATERIAL		SEE NOTES	
Third Angle Projection:			
GENERAL SPECIFICATIONS		SunModo Corp. 14800 NE 65TH STREET, VANCOUVER WA 98682	
Tolerances		TITLE	
X.XXX ±0.01 [0.25mm] X.XX ±0.02 [0.50mm] X.X ±0.039 [1.0mm] Unless otherwise spec'd		2.5" PIPE TEE KIT	
DRAWN BY	DATE	DRAWING NUMBER	
LWF	06/12/2018	B K10341-001	
CHECKED BY		SCALE: NONE SHEET 1 of 1	
APPROVALS			

THIS DRAWING IS CONFIDENTIAL PROPERTY OF SUNMODO AND ITS CONTENTS MAY NOT BE DISCLOSED WITHOUT THE PRIOR WRITTEN CONSENT OF SUNMODO CORP.

REVISIONS			
REV	DESCRIPTION	BY	DATE
A	INITIAL RELEASE	LWF	06/12/2018

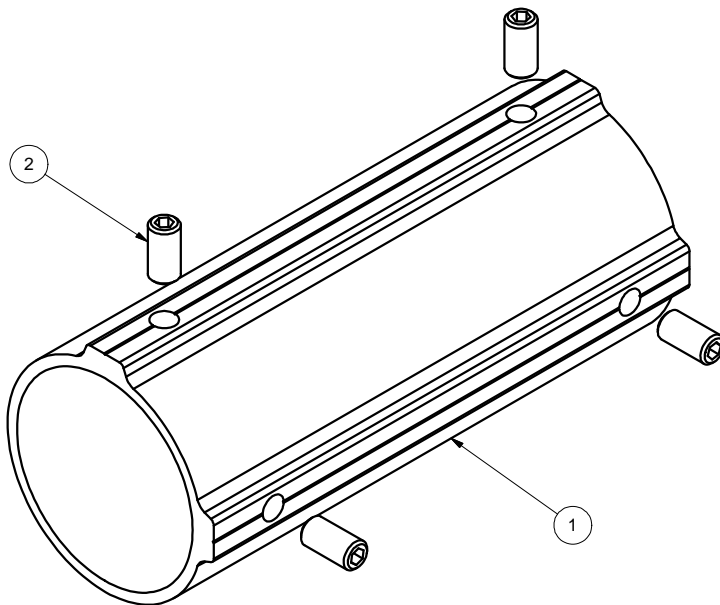

2	B10001-001	SET SCREW M10X20	4
1	A20328-001	2.5" PIPE SPLICE	1
ITEM	PART NUMBER	DESCRIPTION	QTY
MATERIAL		SEE NOTES	
Third Angle Projection:			
GENERAL SPECIFICATIONS		SunModo Corp. 14800 NE 65TH STREET, VANCOUVER WA 98682	
All Dimensions in inches [millimeters] Tolerances X.XXX ±0.01 [0.25mm] X.XX ±0.02 [0.50mm] X.X ±0.039 [1.0mm] Unless otherwise spec'd		TITLE 2.5" PIPE SPLICE KIT	
DRAWN BY	DATE	DRAWING NUMBER	
LWF	06/12/2018	B K10342-001	
CHECKED BY			
APPROVALS		SCALE: NONE	SHEET 1 of 1

THIS DRAWING IS CONFIDENTIAL PROPERTY OF SUNMODO AND ITS CONTENTS MAY NOT BE DISCLOSED WITHOUT THE PRIOR WRITTEN CONSENT OF SUNMODO CORP.

NOTES: UNLESS OTHERWISE SPECIFIED

1. DIMENSIONS SHOWN ARE INCHES [MILIMETERS].
2. MATERIAL:HIGH STRENGTH STEEL PIPE OR TUBE.
3. FINISH: HOT DIP GALVANIZE PER ASTM A123 / A123M - 02.

MINIMUM 50 KSI YIELD STRESS.

4. BREAK ALL BURRS AND SHARP EDGES.

5. ALL WELDING MUST BE IN COMPLIANCE WITH AWS CODE D1;1.

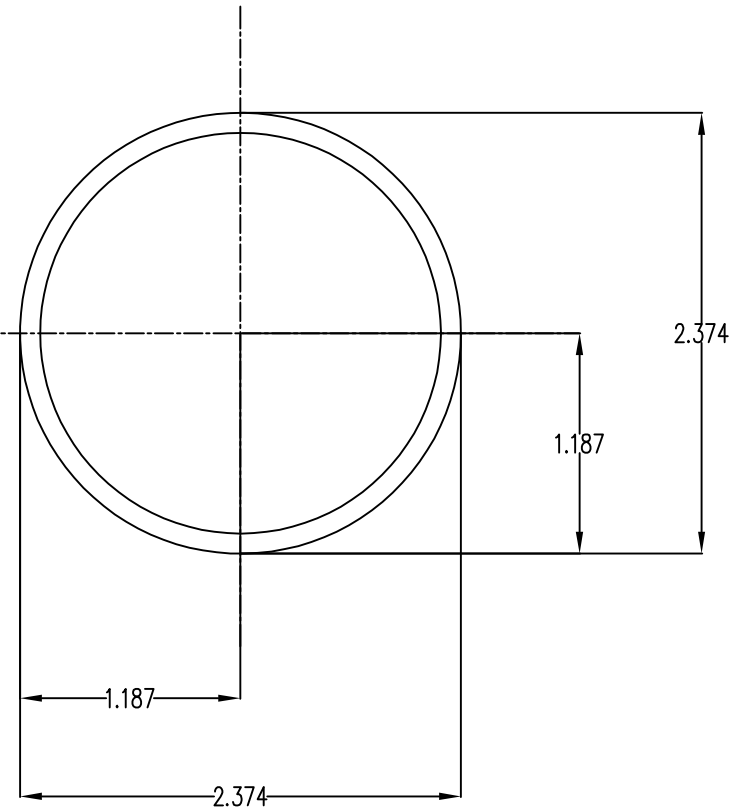

Section properties:

Weight: 2.641 lbs/ft

Area: 0.776 in²

Perimeter: 14.238 in

Bounding Box: X: -1.187,1.187

Y: -1.187,1.187

Centroid:(0.000,0.000)

Moments of Inertia(in⁴): Ix=0.499,Iy=0.499

Section modulus in bending(in³): Wx=0.420,Wy=0.420

Radii of Gyration: X: 0.802, Y: 0.802

MATERIAL		SEE NOTES		Sunmodo Corp. 14800 NE 85TH STREET, VANCOUVER WA 98682	
Third Angle Projection:					
GENERAL SPECIFICATIONS				TITLE	
All Dimensions in Inches (millimeters)				PIPE, HSS, 2.375" OD X 12 GAUGE,L=XXX	
Tolerances				Break all sharp edges .010-.020 unless otherwise specified.	
XXX ±0.01 (0.25mm)					
XX ±0.02 (0.50mm)					
X ±0.050 (1.2mm)					
Unless otherwise specified					
DRAWN BY	DATE	B		DRAWING NUMBER	
LWF	04/03/2019			A21165	
CHECKED BY					
APPROVALS				SCALE: NONE SHEET 1 of 1	

NOTES: UNLESS OTHERWISE SPECIFIED

1. DIMENSIONS SHOWN ARE INCHES [MILIMETERS].
2. MATERAIL:HIGH STRENGTH STEEL PIPE OR TUBE.
3. FINISH: HOT DIP GALVANIZE PER ASTM A123 / A123M - 02.

MINIMUM 50 KSI YIELD STRESS.

4. BREAK ALL BURRS AND SHARP EDGES.
5. ALL WELDING MUST BE IN COMPLIANCE WITH AWS CODE D1;1.

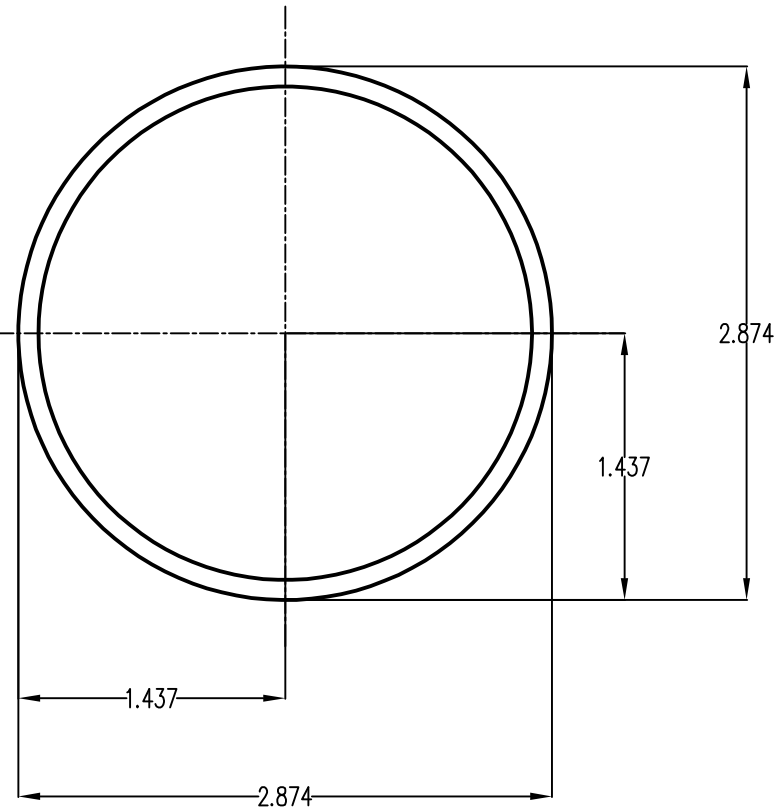

Section properties:

Weight: 3.201 lbs/ft

Area: 0.941 in²

Perimeter: 17.378 in

Bounding Box: X: -1.437,1.437

Y: -1.437,1.437

Centroid:(0.000,0.000)

Moments of Inertia(in⁴): Ix=0.901,Iy=0.901

Section modulus in bending(in³): Wx=0.627,Wy=0.627

Radii of Gyration: X: 0.979, Y: 0.979

MATERIAL		SEE NOTES				<h2>Sunmodo Corp.</h2> <p>14800 NE 85TH STREET, VANCOUVER WA 98682</p>	
Third Angle Projection:							
GENERAL SPECIFICATIONS All Dimensions in Inches (millimeters)				Break all sharp edges .010-.020 unless otherwise specified.		TITLE PIPE, HSS, 2.875" OD X 12 GAUGE,L=XXX	
Tolerances XXXX ±0.01 (0.25mm) XXX ±0.02 (0.50mm) XX ±0.030 (1.0mm) Unless otherwise specified						DRAWING NUMBER A21168	
DRAWN BY LWF		DATE 04/03/2019		B			
CHECKED BY							
APPROVALS				SCALE:		NONE	
						SHEET 1 of 1	