



Project Number: U2716-094-191

August 6, 2019

Sunmodo  
14800 NE 65<sup>th</sup> Street  
Vancouver, WA 98682

**REFERENCE: Sunmodo Sunturf Ground Mount B1  
Ground Mount PV Array Installation**

To Whom It May Concern:

Per request of Sunmodo, we have been asked to prepare the structural design of a ground-mounted PV solar array system with several foundation options as shown in the attached calculations. The adopted building code in this jurisdiction is the South Carolina Building Code, 2015 (2015 IBC). Vector Structural Engineering requires that we review each site specific install, and we are not liable for installs at site specific locations we have not reviewed. The following design parameters are used in our analysis:

- Minimum Design Loads for Buildings and Other Structures (ASCE 7-10)
- Design wind speed for risk category I structures: 105 mph
- Wind exposure: C
- Ground snow load: 30 psf
- The ground screws and helical piers must be tested to 1.5 times uplift and 2.0 times lateral reactions found in the table below. A minimum of one ground screw or helical pier must be tested.

Load (ASD)	Value (lbs)	Factor of Safety	Test Value (lbs)
UPLIFT	2400	1.5	3600
LATERAL	1710	2	3420

Foundation concrete shall have a minimum compressive strength of 2500 psi at 28 days. Cement for all concrete shall be Type I or II with a minimum of 6% entrained air with a water/cement ratio of 0.50. Maximum aggregate size shall be 3/4". No special inspection of concrete strength is required.

Footings are designed based on an allowable soil bearing pressure of 1500 psf an allowable skin friction of 250 psf, an allowable lateral bearing pressure of 150 pcf, and a coefficient of friction of 0.3. Vector Structural Engineering strongly recommends independent soils testing be performed by a licensed geotechnical engineer to verify the assumed soil parameters.

All ground mounts are to be installed per manufacturer’s recommendations. The use of solar panel support span tables provided by the manufacturer is allowed only where the site conditions and solar panel configuration match the description of the span tables. Electrical engineering is beyond our scope. All work performed must be in accordance with accepted industry-wide methods and applicable safety standards. Vector Structural Engineering assumes no responsibility for improper installation of the solar panels.

Very truly yours,

VECTOR STRUCTURAL ENGINEERING, LLC  
Firm License: COA #4120

\_\_\_\_\_  
Roger Alworth, P.E.  
License: 26669 - Expires: 06/30/2020  
Principal

Enclosures

RTA/stb

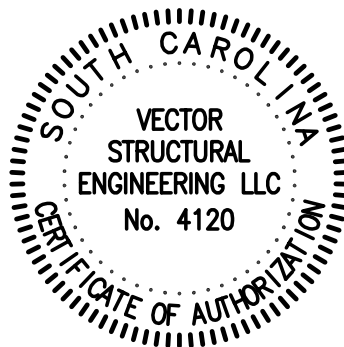

08/06/2019



JOB NO. U2716-094-191  
 PROJECT SUNMODO SUNTURF GROUND MOUNTS B1  
 SUBJECT ALL OPTIONS

651 W GALENA PARK BLVD. #101 (801) 990-1775  
 DRAPER, UTAH 84020 (801) 990-1776 FAX

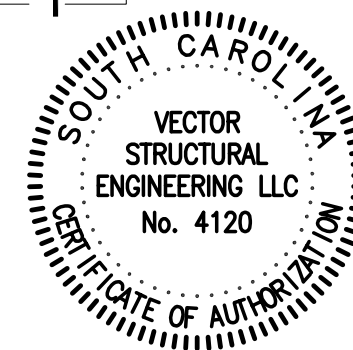
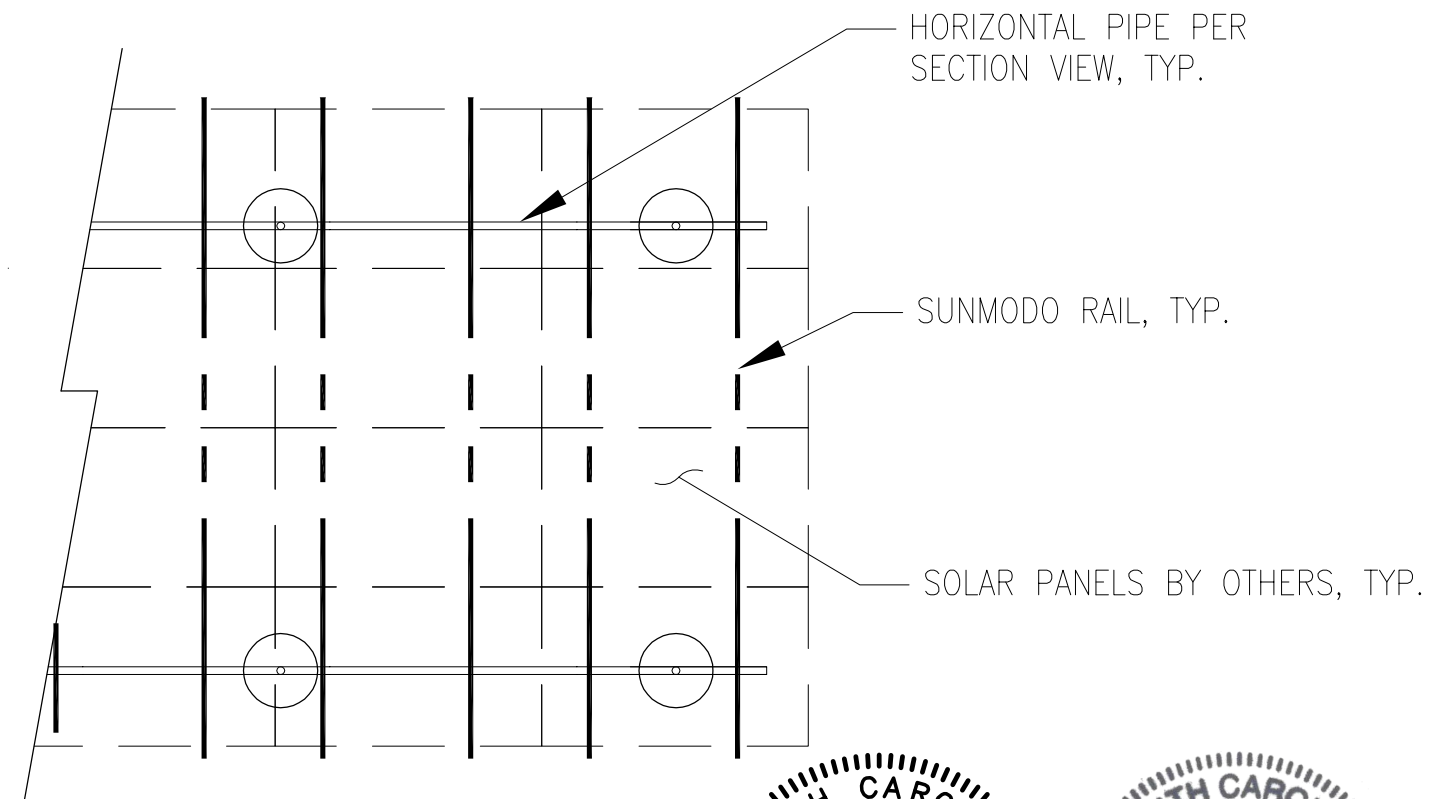
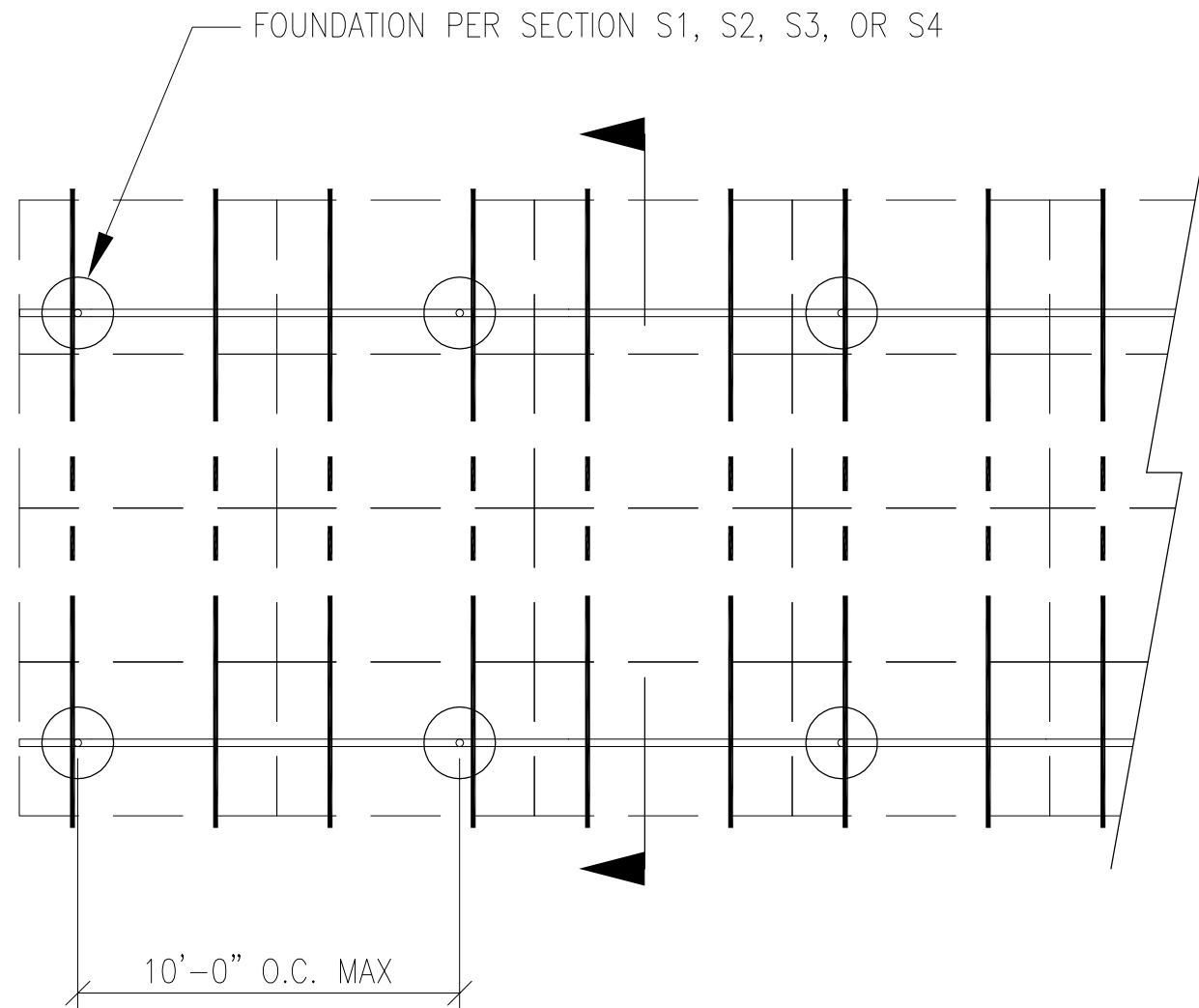

**PV ARRAY PLAN**

N.T.S.

**P1** 08/06/2019

Vector Engineers requires that we review each site specific install and is not liable for installs at site specific locations we have not reviewed.

PROJECT SUNMODO SUNTURF GROUND MOUNTS B1

SUBJECT DRILLED PIER OPTION

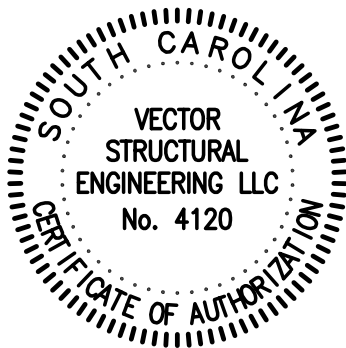
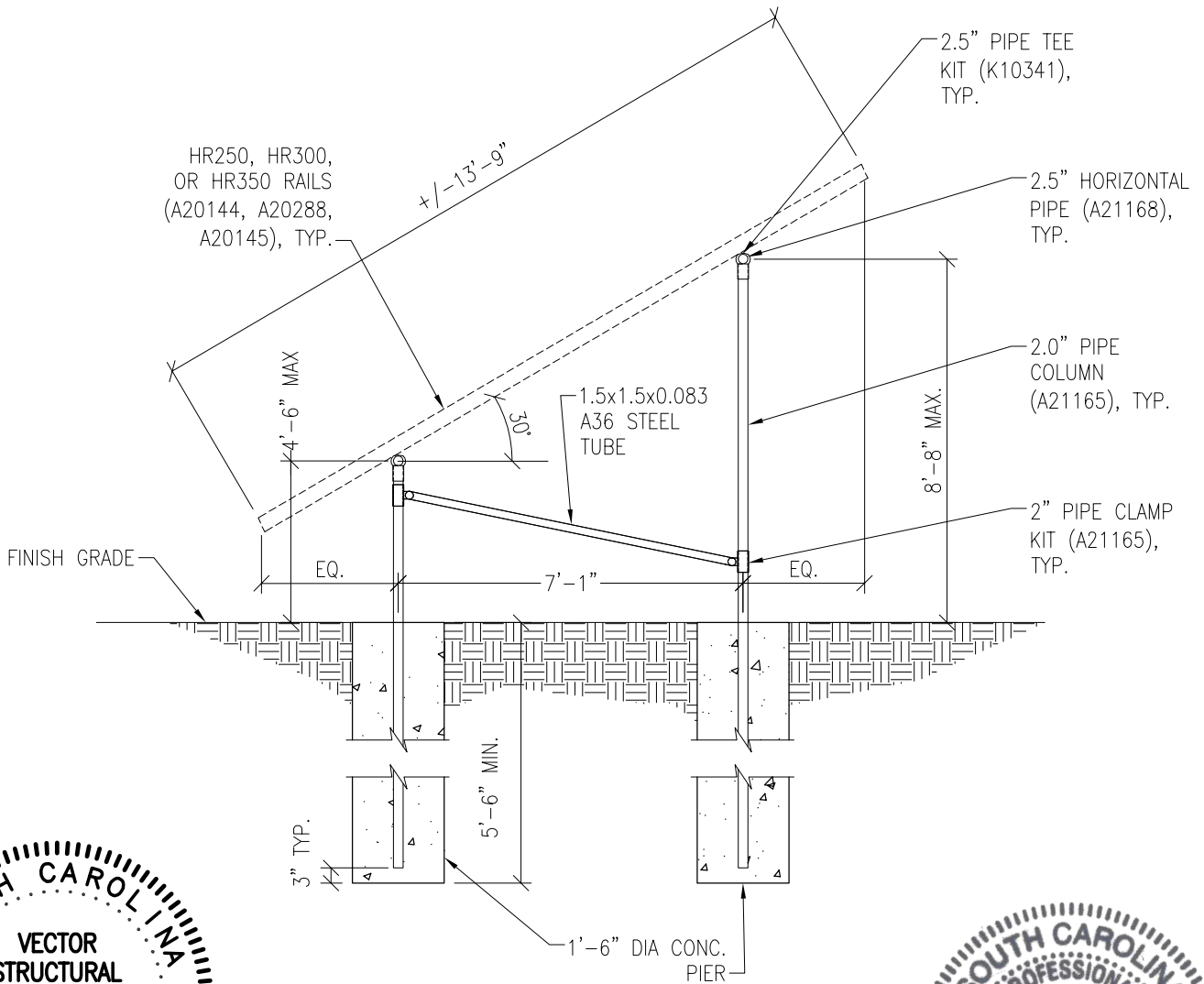

Vector Engineers requires that we review each site specific install and is not liable for installs at site specific locations we have not reviewed.

**PV ARRAY SECTION**

N.T.S.

08/06/2019

**S1**

PROJECT SUNMODO SUNTURF GROUND MOUNTS B1

SUBJECT HELICAL PIER OPTION

**NOTES:**

1. For ground mount components see Section S1.
2. A minimum of (1) helical pier must be load-tested as follows:
  - 2.1. Safety factor for uplift = 1.5,
  - 2.2. Safety factor for lateral loads = 2.0
  - 2.3. Upward deflection limit = 1/2"
  - 2.4. Lateral deflection limit = 1"
  - 2.5. The load tests must be performed by an approved contractor.

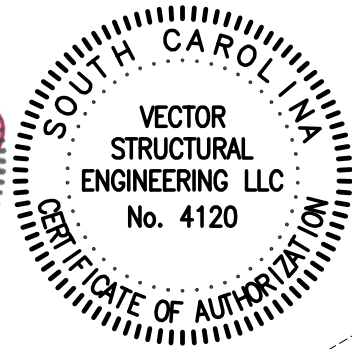

03/26/2020

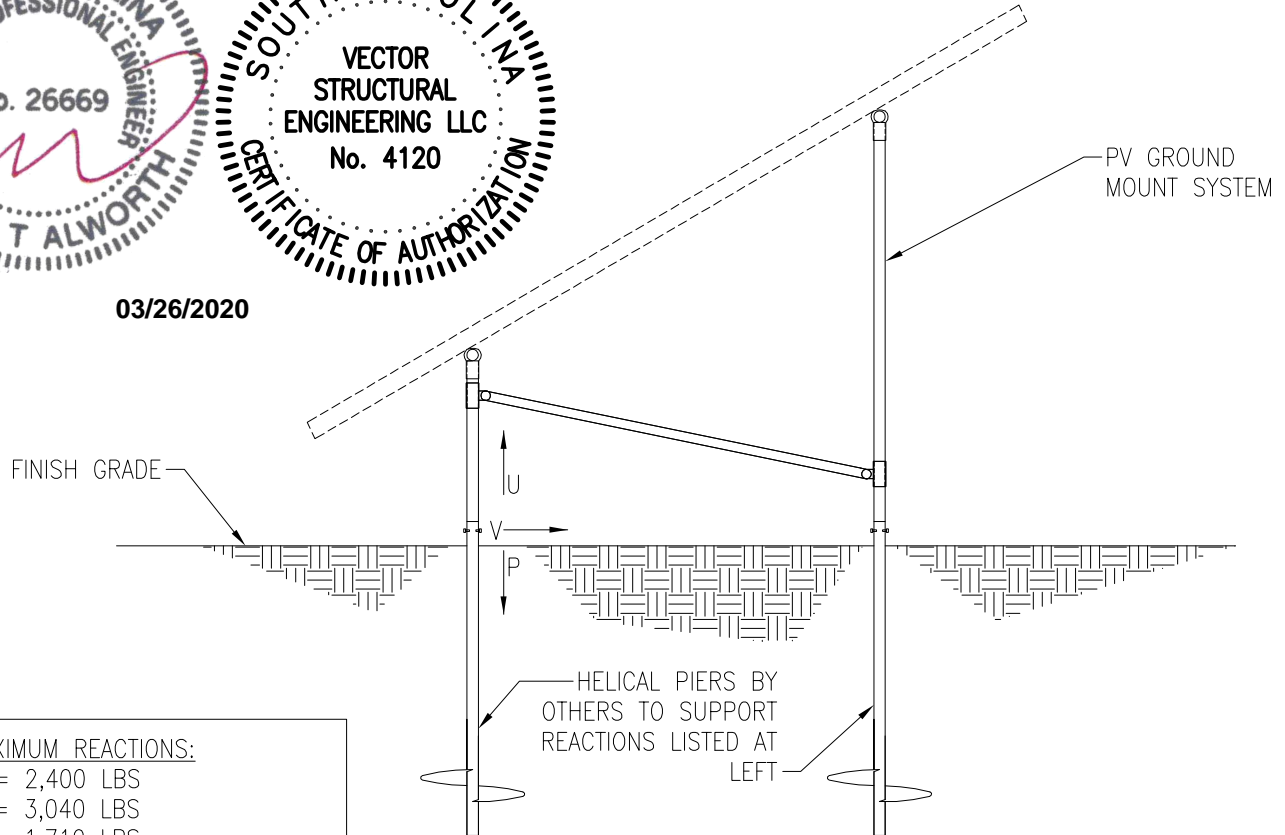

**MAXIMUM REACTIONS:**  
 U = 2,400 LBS  
 P = 3,040 LBS  
 V = 1,710 LBS

**PV ARRAY SECTION**

N.T.S.



JOB NO. U2716-094-191

PROJECT SUNMODO SUNTURF GROUND MOUNTS B1

SUBJECT GROUND SCREW OPTION

NOTES:

- 1. For ground mount components see Section S1.
- 2. A minimum of (1) ground screw must be load-tested as follows:
  - 2.1. Safety factor for uplift = 1.5,
  - 2.2. Safety factor for lateral loads = 2.0
  - 2.3. Upward deflection limit = 1/2"
  - 2.4. Lateral deflection limit = 1"
  - 2.5. The load tests must be performed by an approved contractor.

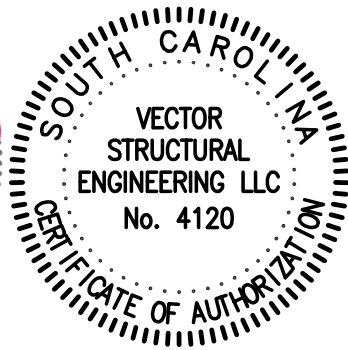

03/26/2020

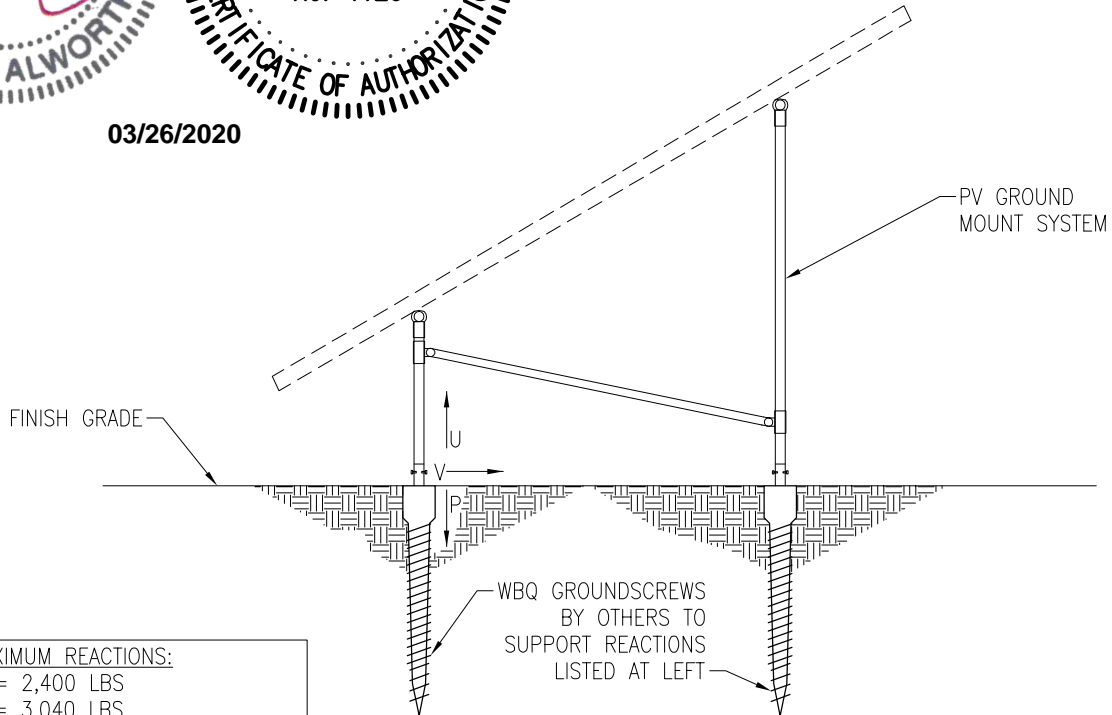

MAXIMUM REACTIONS:  
 U = 2,400 LBS  
 P = 3,040 LBS  
 V = 1,710 LBS

PV ARRAY SECTION

N.T.S.

PROJECT SUNMOD0 SUNTURF GROUND MOUNTS B1

SUBJECT BALLASTED BLOCK OPTION

**NOTES:**

1. For ground mount components see Section S1.

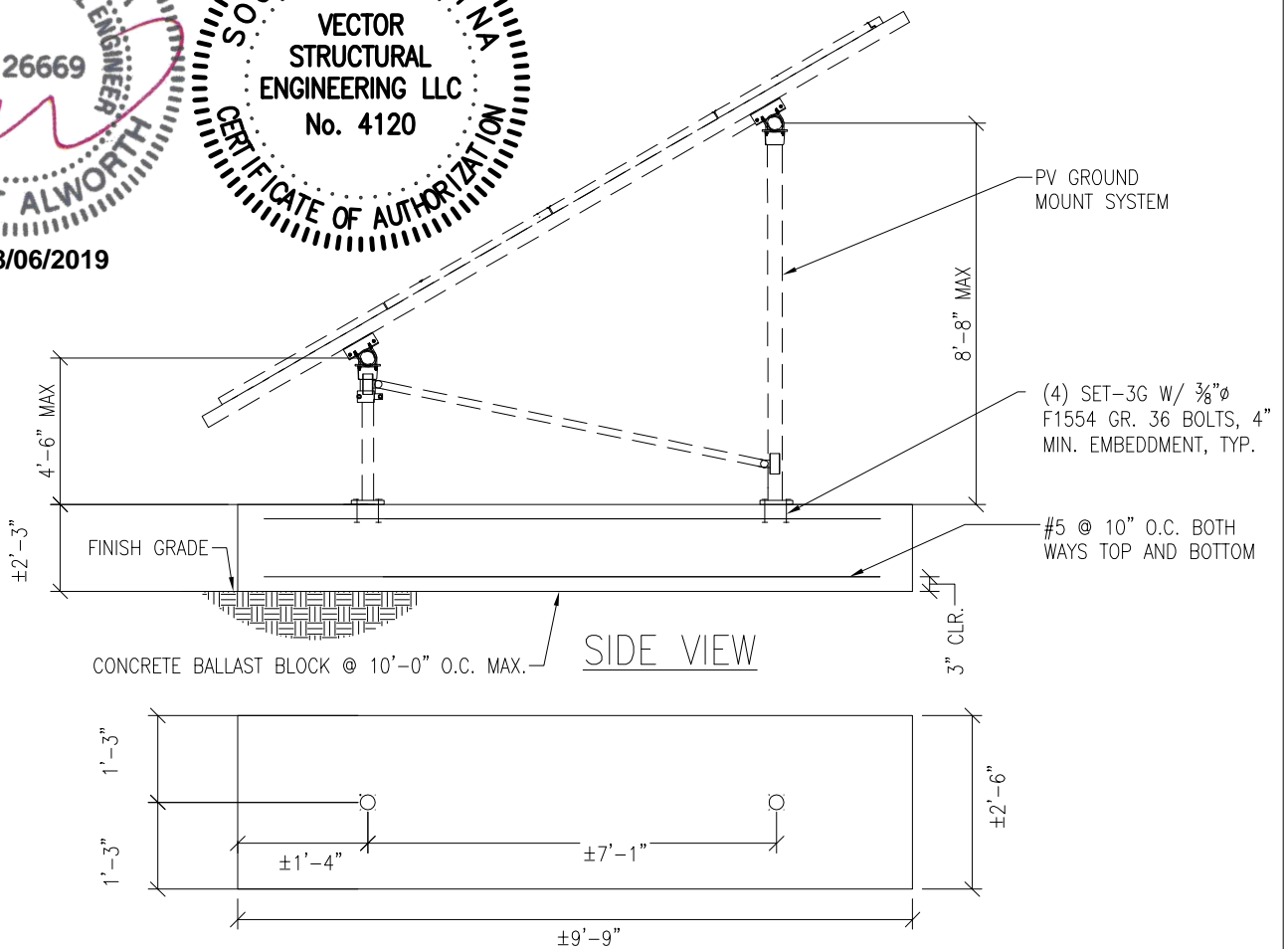
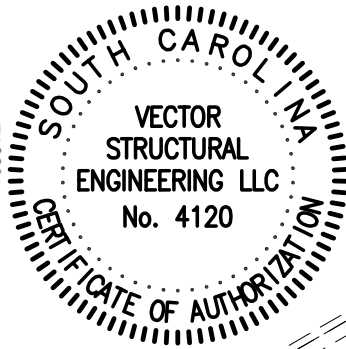

Vector Engineers requires that we review each site specific install and is not liable for installs at site specific locations we have not reviewed.

**PV ARRAY SECTION**

N.T.S.

**S4**

PROJECT: B1 – Sunmodo Sunturf GM

SUBJECT: Dead Load

**Design Weight:**

Individual Panel Weight [lb]:	50.7
Panel Transverse Length (T5) [in]:	41.2
Panel Transverse Length (T5) [ft]:	3.4
Panel Longitudinal Length (L2) [in]:	81.4
Panel Longitudinal Length (L2) [ft]:	6.8
Individual Panel Area [ft <sup>2</sup> ]:	23.3
Individual Panel Weight [psf]:	2.2
# of Panels in Transverse Direction:	4
Approximate Transverse Length (T4) [ft]:	13.7
# of Panels in Longitudinal Direction:	12
Approximate Longitudinal Length (L1) [ft]:	81.4
Transverse Column Spacing (T1) [ft]:	7.1
Longitudinal Column Spacing (L3) [ft]:	10.0
# of Columns in Longitudinal Direction:	9
# of Columns in Transverse Direction:	2
Total Number of Columns:	18
Panel Slope from Horizontal (a) [°]:	30.0
Short Column Height (H1) [ft]:	4.5
Approximate Tall Column Height (H2) [ft]:	8.6
Transverse Brace between Columns :	Yes
Approximate Brace Length (B1) [ft]:	9.0
Weight of Columns [plf]:	3.7
Weight of Cross Pipe [plf]:	3.7
Weight of Brace [plf]:	3.7
Tributary Transverse Length per Column [ft]:	6.9
Tributary Longitudinal Length per Column [ft]:	10.0
Tributary Area per Column [ft <sup>2</sup> ]:	68.7
Rail Weight [plf]:	1.0
Transverse Rail Weight per Column [lb]:	27.5
Longitudinal Rail Weight per Column [lb]:	36.5
Tall Column Weight [lb]:	31.4
Panel Weight per Column [lb]:	149.5
Rail Weight per Column [lb]:	27.5
Cross Pipe Weight per Column [lb]:	36.5
Brace Weight per Column [lb]:	16.4
<b>Total Weight per Column (1.0 D) [lb]:</b>	<b>261.3</b>

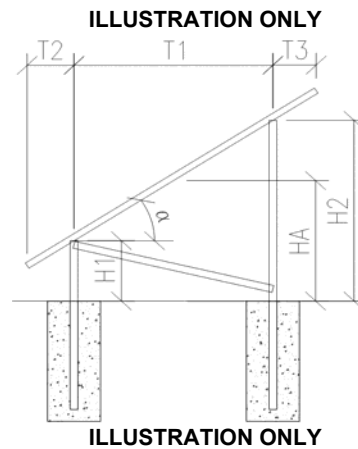
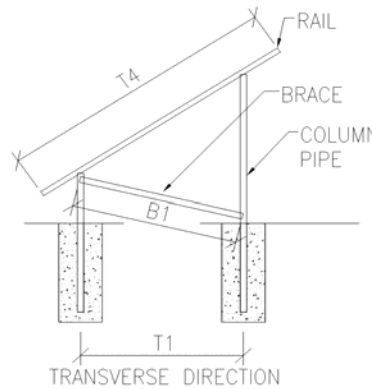
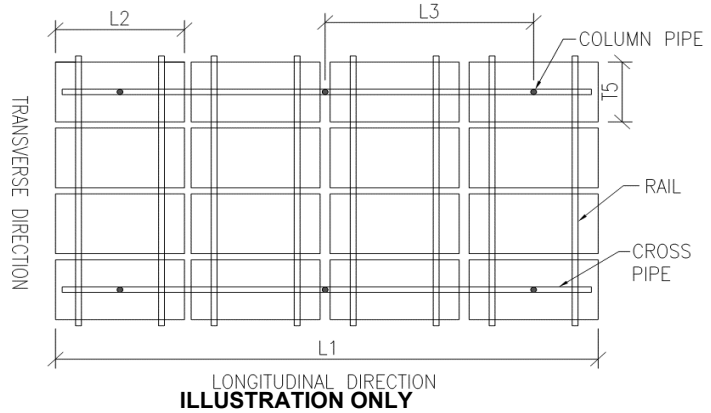

**Assumptions:**

- T2 = T3



JOB NO.: U2716-094-191

DESIGNED: STB

DATE: 07/25/19

PROJECT: B1 – Sunmodo Sunturf GM

SUBJECT: Snow Load

**SNOW LOAD (S):**

ASCE 7 Standard:	10	
Panel Slope from Horizontal [°]:	30.0	
Snow Ground Load, $p_g$ [psf]:	30.0	(Section 7.2)
Terrain Category:	C	(Table 7-2)
Exposure of Roof:	Fully Exposed	(Table 7-2)
Exposure Factor, $C_e$ :	0.9	(Table 7-2)
Thermal Factor, $C_t$ :	1.2	(Table 7-3)
Risk Category:	I	(Table 1.5-1)
Importance Factor, $I_s$ :	0.8	(Table 1.5-2)
Flat Roof Snow Load, $p_f$ [psf]:	18	(Equation 7.3-1)
Minimum Roof Snow Load, $p_m$ [psf]:	0	(Section 7.3.4)
Unobstructed Slippery Surface?	Yes	(Section 7.4)
Slope Factor Figure:	Figure 7-2c	(Section 7.4)
Roof Slope Factor, $C_s$ :	0.727	(Figure 7-2)
Sloped Roof Snow Load, $p_s$ [psf]:	13	(Equation 7.4-1)
Design Snow Load, S [psf]:	13	
Tributary Transverse Length [ft]:	5.9	
Tributary Longitudinal Length [ft]:	10	
Tributary Area per Column [ft <sup>2</sup> ]:	59.5	
<b>Snow Load per Column (1.0 S) [lb]:</b>	<b>784.7</b>	





PROJECT: B1 – Sunmodo Sunturf GM

SUBJECT: Wind Pressure

**Design Wind Load:**

ASCE 7 Standard:	10	
Basic Wind Speed, V [mph]:	105	
Risk Category:	I	
Exposure Category	C	(Section 26.7.3)
Velocity Pressure Exposure Coefficient, $K_h$ :	0.85	(Table 27.3-1)
Topographic Factor, $K_{ht}$ :	1.0	(Section 26.8.2)
Wind Directionality Factor, $K_d$ :	0.85	(Table 26.6-1)
Internal Pressure Coefficient, $GC_{pi}$ :	0.00	(Table 26.11-1)
Velocity Pressure, $q_h$ [psf]:	20.4	(Equation 27.3-1)
Gust Effect Factor, G:	0.85	(Section 26.9.1)
Panel Slope [degrees]:	30.0	

Net Pressure Coefficients ( $C_N$ ) per: (Figure 27.4-4)

Clear Wind Flow	$C_{NW}$	$C_{NL}$
Case 1 ( $\gamma = 0^\circ$ , Load Case A)	-1.80	-1.80
Case 2 ( $\gamma = 0^\circ$ , Load Case B)	-2.50	-0.50
Case 3 ( $\gamma = 180^\circ$ , Load Case A)	2.10	2.10
Case 4 ( $\gamma = 180^\circ$ , Load Case B)	2.60	1.00

Design Wind Pressures (p) [psf] per: (Equation 27.4-3)

Clear Wind Flow	$q_h GC_{NW}$	$q_h GC_{NL}$
Case 1 ( $\gamma = 0^\circ$ , Load Case A)	-31.2	-31.2
Case 2 ( $\gamma = 0^\circ$ , Load Case B)	-43.3	-8.7
Case 3 ( $\gamma = 180^\circ$ , Load Case A)	36.4	36.4
Case 4 ( $\gamma = 180^\circ$ , Load Case B)	45.1	17.3

Wind Pressure on Each Side of Panels [psf]

Clear Wind Flow	Short Col. Pressure	Long Col. Pressure
Case 1 ( $\gamma = 0^\circ$ , Load Case A)	-31.2	-31.2
Case 2 ( $\gamma = 0^\circ$ , Load Case B)	-8.7	-43.3
Case 3 ( $\gamma = 180^\circ$ , Load Case A)	36.4	36.4
Case 4 ( $\gamma = 180^\circ$ , Load Case B)	45.1	17.3



JOB NO.: U2716-094-191

PROJECT: B1 – Sunmodo Sunturf GM

SUBJECT: Open Building Wind Loads

### Design Wind Load Per ASCE 7-10

$$p = q_h G C_n$$

Velocity Pressure Exposure Coefficient, $K_z$ :	0.85	(Table 27.3-1)
Topographic Factor, $K_{zt}$ :	1.0	(Section 26.8.2)
Wind Directionality Factor, $K_d$ :	0.85	(Table 26.6-1)
Ultimate Wind Speed, $V$ [mph]:	105	

Velocity Pressure, $q_h$ [psf]:	20.4	(Equation 27.3-1)
Gust Effect Factor, $G$ :	0.85	(Section 26.9.1)

$\gamma = 90^\circ$  or  $270^\circ$

Force Coefficient,  $C_N$ :

Horizontal Distance from Winward Edge	Roof angle		
	Load Case	Obstructed Wind Flow	
		CN	
$\leq h$	30	A	-0.8
		B	0.8
$> h, \leq 2h$	30	A	-0.6
		B	0.5
$> 2h$	30	A	-0.3
		B	0.3

Design Wind Pressure,  $p$  [psf]:

	Roof angle		
	Load Case	Obstructed Wind Flow	
$\leq h$	30	A	-13.9
		B	13.9
$> h, \leq 2h$	30	A	-10.4
		B	8.7
$> 2h$	30	A	-5.2
		B	5.2



JOB NO.: U2716-094-191

DESIGNED: STB

---

# Foundation Option 1: Drilled Concrete Pier



JOB NO.: U2716-094-191  
DATE: 07/25/19

DESIGNED: STB

PROJECT: B1 – Sunmodo Sunturf GM

**Drilled Pier Design**

**Design Loads:**

Max. Shear, V [k]:	1.7	Max. Down, P <sub>d</sub> [k]:	3.0
Max. Moment, M [k-ft]:	0.0	Max. Uplift, P <sub>u</sub> [k]:	2.4

**Pier Properties:**

Pier Diameter, b [ft]:	1.5	Volume of Concrete [ft <sup>3</sup> ]:	10
Min. Pier Diameter, b <sub>min</sub> (opt'l) [ft]:		Volume of Concrete [yd <sup>3</sup> ]:	0.4
Top of Pier Elevation [ft]:	0.00	Weight of Concrete [k]:	1.5
Pier Depth, d [ft]:	5.5		
Min. Pier Depth, d <sub>min</sub> (opt'l) [ft]:			
Max. Pier Depth, d <sub>max</sub> (opt'l) [ft]:			

**Soil Properties:**

Allow. Bearing Pressure [psf]:	1,500	<u>Optional Parameters for Uplift:</u>	
1/3 increase for short term loads?	No	Skin Friction [psf]:	250 (IBC 1810.3.3.1.4)
Lateral Bearing, S [pcf]:	150	Top Length to Ignore [ft]:	0.0
Max. Lateral Bearing (opt'l) [psf]:		1/3 increase for short term loads?	No
Top Depth to Ignore [ft]:	0.0	Combine w/ Bearing:	No
1/3 increase for short term loads?	No		
1/2" deflection at t/o pier allowed:	Yes		

**Check Bearing:**

Bearing Capacity [k]: 6.5      **Bearing capacity OK.**

**Check Uplift:**

Uplift Capacity [k]: 7.8      **Uplift capacity OK.**

**Check Lateral Bearing:**

Applied Lateral Force, P [lb]:	1,710	
Point of Application, h [ft]:	0.0	
S <sub>1_max</sub> [psf]:		
S <sub>1</sub> [psf]:	550	
A = 2.34*P/(S <sub>1</sub> b):	4.85	
Required Pier Depth, d <sub>reqd</sub> [ft]:	4.9	<b>Lateral bearing capacity OK.</b>

# Foundation Option 2: Helical Pier

The ground screws and helical piers must be tested to 1.5 times uplift and 2.0 times lateral reactions found in the table below.

Load (ASD)	Value (lbs)	Factor of Safety	Test Value (lbs)
UPLIFT	2400	1.5	3600
LATERAL	1710	2	3420

# Foundation Option 3: Ground Screw

The ground screws and helical piers must be tested to 1.5 times uplift and 2.0 times lateral reactions found in the table below.

Load (ASD)	Value (lbs)	Factor of Safety	Test Value (lbs)
UPLIFT	2400	1.5	3600
LATERAL	1710	2	3420



JOB NO.: U2716-094-191

DESIGNED: STB

---

# Foundation Option 4: Ballasted Block

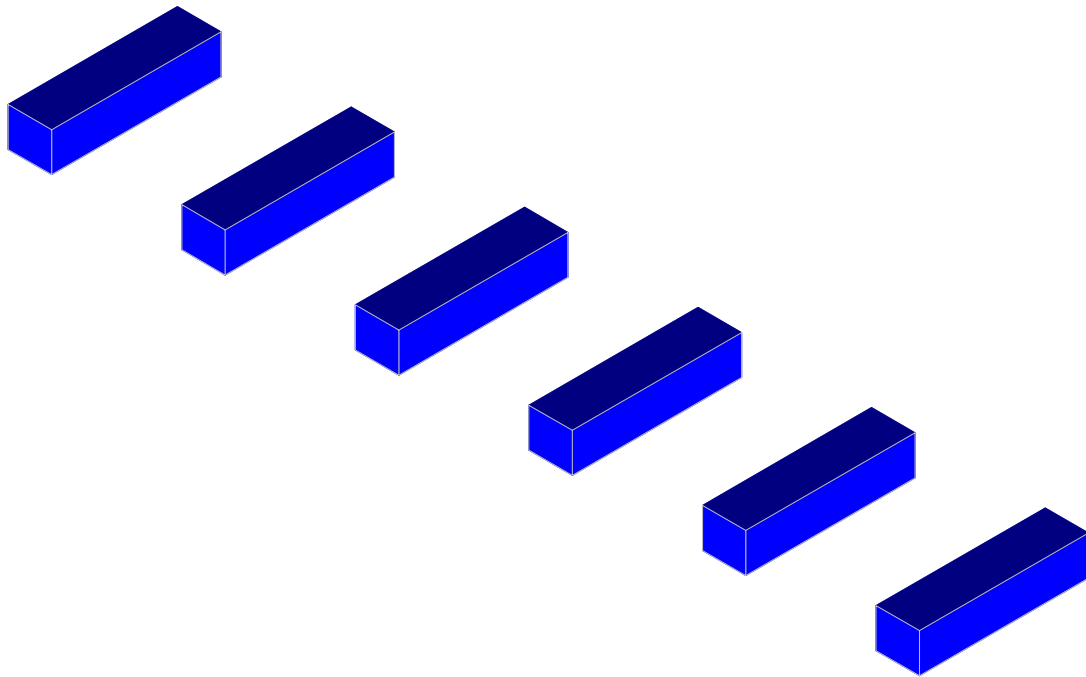

Results for LC 1, 1.0 D

Vector Structural Engineeri..	Ground Mount	SK - 14
STB		June 7, 2019 at 4:41 PM
U2716.094.191		USA B1 GM v3.r3d



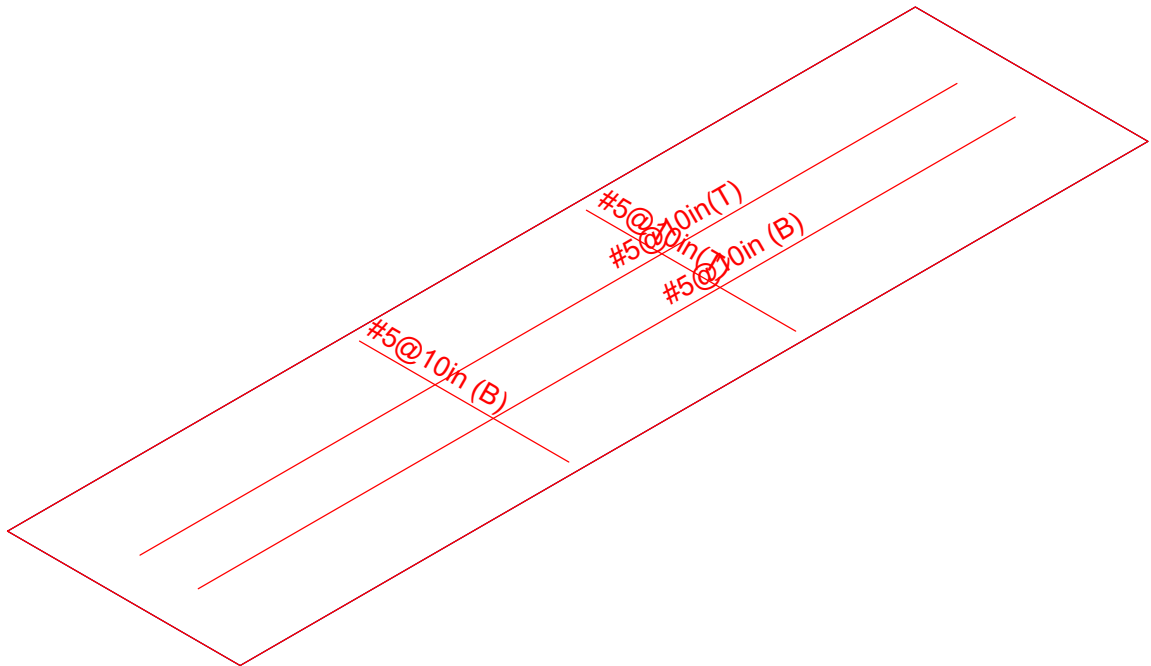

Results for LC 1, 1.0 D

Vector Structural Engineeri..	Ground Mount	SK - 15
STB		June 7, 2019 at 4:41 PM
U2716.094.191		USA B1 GM v3.r3d



Company : Vector Structural Engineering  
 Designer : STB  
 Job Number : U2716.094.191  
 Model Name : Ground Mount

July 25, 2019  
 4:23 PM  
 Checked By: JSP

### **(Global) Model Settings**

Display Sections for Member Calcs	5
Max Internal Sections for Member Calcs	100
Mesh Size (in)	12
Max Iterations	10
Merge Tolerance (in)	.12
Solver	Sparse Accelerated
Coefficient of Friction	.3
No. of Shear Regions	4
Shear Region Spacing Increment (in)	4
Min 1 Bar Dia Spacing for Beams?	No
Optimize footings for OTM / Sliding?	Yes
Parame Beta Factor	.65
Pile Safety Factor	3
Concrete Stress Block	Rectangular
Concrete Rebar Set	ASTM A615
Concrete Code	ACI 318-14
HR Steel Pile Code	AISC 14th(360-10): ASD
Wood Pile Code	AWC NDS-15: ASD

### **Concrete Properties**

	Label	E [ksi]	G [ksi]	Nu	Therm (\...	Density[lb/ft^3]	fc[psi]	Lambda	Flex Stee...	Shear St...
1	Conc3000NW	3156	1372	.15	.6	145	3000	1	60000	60000
2	Conc3500NW	3409	1482	.15	.6	145	3500	1	60000	60000
3	Conc4000NW	3644	1584	.15	.6	145	4000	1	60000	60000
4	Conc3000LW	2085	907	.15	.6	109.999	3000	.75	60000	60000
5	Conc3500LW	2252	979	.15	.6	109.999	3500	.75	60000	60000
6	Conc4000LW	2408	1047	.15	.6	109.999	4000	.75	60000	60000
7	Conc2500NW	3156	1372	.15	.6	145	2500	1	60000	60000

### **General Design Parameters**

	Label	Max Bending Chk	Max Shear Chk	Top Cover[in]	Bottom Cover[in]
1	Typical	1	1	3	3

### **Slab Rebar Parameters**

	Label	Top Bar	Bottom Bar	Max Top Bar Sp...	Min Top Bar Sp...	Max Bot Bar Sp...	Min Bot Bar Sp...	Spacing Incr...	Rebar Options
1	Typical	#5	#5	10	10	10	10	1	Optimize

### **Soil Definitions**

	Label	Subgrade Modulus[lb/ft^3]	Allowable Bearing[psf]	Depth Properties	Default?
1	Default	1e+5	1500	None	Yes

### **Point Loads and Moments (Cat 1 : DL)**

	Label	Direction	Magnitude[lb,lb-ft]
1	R3D_N1_1	X	-32.142
2	R3D_N1_1	Y	231.457
3	R3D_N2_1	X	-16.172
4	R3D_N2_1	Y	206.36
5	R3D_N132	Y	260.329
6	R3D_N133	X	-2.398
7	R3D_N133	Y	306.853
8	R3D_N109	X	-1.038
9	R3D_N109	Y	260.065

**Point Loads and Moments (Cat 1 : DL) (Continued)**

	Label	Direction	Magnitude[lb,lb-ft]
10	R3D_N110A	X	2.286
11	R3D_N110A	Y	306.683
12	R3D_N121	Y	277.767
13	R3D_N122	Y	289.617
14	R3D_N133B	Y	277.69
15	R3D_N134B	Y	289.62
16	R3D_N137C	X	32.232
17	R3D_N137C	Y	230.375
18	R3D_N138B	X	16.369
19	R3D_N138B	Y	205.202

**Point Loads and Moments (Cat 6 : RLL)**

	Label	Direction	Magnitude[lb,lb-ft]
1	R3D_N1_1	X	-93.573
2	R3D_N1_1	Y	574.454
3	R3D_N2_1	X	-49.04
4	R3D_N2_1	Y	564.726
5	R3D_N132	X	3.151
6	R3D_N132	Y	679.935
7	R3D_N133	X	-7.195
8	R3D_N133	Y	869.351
9	R3D_N109	X	-3.311
10	R3D_N109	Y	679.16
11	R3D_N110A	X	6.863
12	R3D_N110A	Y	868.837
13	R3D_N121	X	1.653
14	R3D_N121	Y	734.19
15	R3D_N122	Y	815.856
16	R3D_N133B	X	-1.749
17	R3D_N133B	Y	733.97
18	R3D_N134B	X	-1.225
19	R3D_N134B	Y	815.879
20	R3D_N137C	X	93.828
21	R3D_N137C	Y	571.299
22	R3D_N138B	X	49.631
23	R3D_N138B	Y	561.324

**Point Loads and Moments (Cat 16 : OL1)**

	Label	Direction	Magnitude[lb,lb-ft]
1	R3D_N1_1	X	225.096
2	R3D_N1_1	Y	-2640.624
3	R3D_N1_1	Z	1461.148
4	R3D_N2_1	X	132.613
5	R3D_N2_1	Y	-96.347
6	R3D_N2_1	Z	-58.986
7	R3D_N132	X	-8.945
8	R3D_N132	Y	-3772.492
9	R3D_N132	Z	2441.47
10	R3D_N133	X	20.197
11	R3D_N133	Y	57.017
12	R3D_N133	Z	-77.292
13	R3D_N109	X	9.103
14	R3D_N109	Y	-3769.513
15	R3D_N109	Z	2439.879
16	R3D_N110A	X	-19.168
17	R3D_N110A	Y	57.325

**Point Loads and Moments (Cat 16 : OL1) (Continued)**

	Label	Direction	Magnitude[lb,lb-ft]
18	R3D_N110A	Z	-77.335
19	R3D_N121	X	-5.757
20	R3D_N121	Y	-3681.68
21	R3D_N121	Z	2183.614
22	R3D_N122	X	3.362
23	R3D_N122	Y	-38.397
24	R3D_N122	Z	-77.294
25	R3D_N133B	X	5.822
26	R3D_N133B	Y	-3682.902
27	R3D_N133B	Z	2184.859
28	R3D_N134B	X	-2.796
29	R3D_N134B	Y	-36.73
30	R3D_N134B	Z	-77.333
31	R3D_N137C	X	-225.316
32	R3D_N137C	Y	-2625.34
33	R3D_N137C	Z	1451.735
34	R3D_N138B	X	-134.208
35	R3D_N138B	Y	-95.852
36	R3D_N138B	Z	-58.758

**Point Loads and Moments (Cat 17 : OL2)**

	Label	Direction	Magnitude[lb,lb-ft]
1	R3D_N1_1	X	304.012
2	R3D_N1_1	Y	-3090.732
3	R3D_N1_1	Z	1224.344
4	R3D_N2_1	X	50.159
5	R3D_N2_1	Y	704.239
6	R3D_N2_1	Z	-49.443
7	R3D_N132	X	-11.637
8	R3D_N132	Y	-4278.666
9	R3D_N132	Z	2047.955
10	R3D_N133	X	4.179
11	R3D_N133	Y	1269.503
12	R3D_N133	Z	-64.824
13	R3D_N109	X	11.887
14	R3D_N109	Y	-4275.583
15	R3D_N109	Z	2047.176
16	R3D_N110A	X	-3.593
17	R3D_N110A	Y	1269.446
18	R3D_N110A	Z	-64.876
19	R3D_N121	X	-7.364
20	R3D_N121	Y	-4248.303
21	R3D_N121	Z	1829.455
22	R3D_N122	X	5.123
23	R3D_N122	Y	1115.506
24	R3D_N122	Z	-64.764
25	R3D_N133B	X	7.475
26	R3D_N133B	Y	-4250.023
27	R3D_N133B	Z	1831.337
28	R3D_N134B	X	-4.895
29	R3D_N134B	Y	1117.712
30	R3D_N134B	Z	-64.817
31	R3D_N137C	X	-304.369
32	R3D_N137C	Y	-3073.277
33	R3D_N137C	Z	1216.63
34	R3D_N138B	X	-50.973

**Point Loads and Moments (Cat 17 : OL2) (Continued)**

	Label	Direction	Magnitude[lb,lb-ft]
35	R3D_N138B	Y	700.114
36	R3D_N138B	Z	-49.26

**Point Loads and Moments (Cat 18 : OL3)**

	Label	Direction	Magnitude[lb,lb-ft]
1	R3D_N1_1	X	-262.612
2	R3D_N1_1	Y	3080.728
3	R3D_N1_1	Z	-1704.673
4	R3D_N2_1	X	-154.715
5	R3D_N2_1	Y	112.405
6	R3D_N2_1	Z	68.817
7	R3D_N132	X	10.436
8	R3D_N132	Y	4401.24
9	R3D_N132	Z	-2848.382
10	R3D_N133	X	-23.564
11	R3D_N133	Y	-66.52
12	R3D_N133	Z	90.174
13	R3D_N109	X	-10.62
14	R3D_N109	Y	4397.765
15	R3D_N109	Z	-2846.525
16	R3D_N110A	X	22.363
17	R3D_N110A	Y	-66.879
18	R3D_N110A	Z	90.224
19	R3D_N121	X	6.717
20	R3D_N121	Y	4295.293
21	R3D_N121	Z	-2547.549
22	R3D_N122	X	-3.923
23	R3D_N122	Y	44.796
24	R3D_N122	Z	90.176
25	R3D_N133B	X	-6.793
26	R3D_N133B	Y	4296.718
27	R3D_N133B	Z	-2549.002
28	R3D_N134B	X	3.262
29	R3D_N134B	Y	42.851
30	R3D_N134B	Z	90.221
31	R3D_N137C	X	262.869
32	R3D_N137C	Y	3062.896
33	R3D_N137C	Z	-1693.691
34	R3D_N138B	X	156.576
35	R3D_N138B	Y	111.828
36	R3D_N138B	Z	68.551

**Point Loads and Moments (Cat 19 : OL4)**

	Label	Direction	Magnitude[lb,lb-ft]
1	R3D_N1_1	X	-131.547
2	R3D_N1_1	Y	1925.367
3	R3D_N1_1	Z	-1455.749
4	R3D_N2_1	X	-181.104
5	R3D_N2_1	Y	726.691
6	R3D_N2_1	Z	58.755
7	R3D_N132	X	5.585
8	R3D_N132	Y	2860.617
9	R3D_N132	Z	-2430.706
10	R3D_N133	X	-30.363
11	R3D_N133	Y	924.812
12	R3D_N133	Z	76.96

**Point Loads and Moments (Cat 19 : OL4) (Continued)**

	Label	Direction	Magnitude[lb,lb-ft]
13	R3D_N109	X	-5.646
14	R3D_N109	Y	2858.121
15	R3D_N109	Z	-2428.676
16	R3D_N110A	X	29.115
17	R3D_N110A	Y	924.253
18	R3D_N110A	Z	76.99
19	R3D_N121	X	3.695
20	R3D_N121	Y	2733.397
21	R3D_N121	Z	-2175.758
22	R3D_N122	X	-1.498
23	R3D_N122	Y	960.379
24	R3D_N122	Z	77.011
25	R3D_N133B	X	-3.715
26	R3D_N133B	Y	2734.055
27	R3D_N133B	Z	-2176.325
28	R3D_N134B	Y	959.368
29	R3D_N134B	Z	77.033
30	R3D_N137C	X	131.627
31	R3D_N137C	Y	1913.874
32	R3D_N137C	Z	-1446.231
33	R3D_N138B	X	183.113
34	R3D_N138B	Y	722.55
35	R3D_N138B	Z	58.521

**Point Loads and Moments (Cat 20 : OL5)**

	Label	Direction	Magnitude[lb,lb-ft]
1	R3D_N1_1	X	-73.937
2	R3D_N1_1	Y	1155.083
3	R3D_N1_1	Z	-649.695
4	R3D_N2_1	X	-45.664
5	R3D_N2_1	Y	25.47
6	R3D_N2_1	Z	23.184
7	R3D_N132	X	6.502
8	R3D_N132	Y	610.134
9	R3D_N132	Z	-405.766
10	R3D_N133	Y	-10.941
11	R3D_N133	Z	12.956
12	R3D_N109	X	5.707
13	R3D_N109	Y	1205.466
14	R3D_N109	Z	-779.431
15	R3D_N110A	X	20.687
16	R3D_N110A	Y	-23.332
17	R3D_N110A	Z	23.517
18	R3D_N121	X	4.552
19	R3D_N121	Y	591.517
20	R3D_N121	Z	-347.967
21	R3D_N122	Y	14.352
22	R3D_N122	Z	15.222
23	R3D_N133B	X	2.567
24	R3D_N133B	Y	620.028
25	R3D_N133B	Z	-367.49
26	R3D_N134B	X	2.885
27	R3D_N134B	Y	5.001
28	R3D_N134B	Z	13.35
29	R3D_N137C	X	54.657
30	R3D_N137C	Y	459.744



**Point Loads and Moments (Cat 20 : OL5) (Continued)**

	Label	Direction	Magnitude[lb,lb-ft]
31	R3D N137C	Z	-242.578
32	R3D N138B	X	21.945
33	R3D N138B	Y	14.854
34	R3D N138B	Z	9.823

**Point Loads and Moments (Cat 21 : OL6)**

	Label	Direction	Magnitude[lb,lb-ft]
1	R3D N1 1	X	69.187
2	R3D N1 1	Y	-1133.104
3	R3D N1 1	Z	638.915
4	R3D N2 1	X	42.366
5	R3D N2 1	Y	-25.162
6	R3D N2 1	Z	-22.25
7	R3D N132	X	-5.834
8	R3D N132	Y	-612.268
9	R3D N132	Z	405.574
10	R3D N133	Y	10.872
11	R3D N133	Z	-12.934
12	R3D N109	X	-4.827
13	R3D N109	Y	-1051.209
14	R3D N109	Z	684.957
15	R3D N110A	X	-18.791
16	R3D N110A	Y	22.216
17	R3D N110A	Z	-21.418
18	R3D N121	X	-3.849
19	R3D N121	Y	-586.67
20	R3D N121	Z	344.769
21	R3D N122	Y	-14.128
22	R3D N122	Z	-14.6
23	R3D N133B	X	-2.15
24	R3D N133B	Y	-620.759
25	R3D N133B	Z	368.154
26	R3D N134B	X	-2.714
27	R3D N134B	Y	-4.669
28	R3D N134B	Z	-13.242
29	R3D N137C	X	-52.567
30	R3D N137C	Y	-457.396
31	R3D N137C	Z	242.6
32	R3D N138B	X	-21.872
33	R3D N138B	Y	-14.684
34	R3D N138B	Z	-9.818

**Slabs**

	Label	Thickness [in]	Material	Local Axis Angle [deg]	Analysis Offset [in]
1	S1	27	Conc2500NW	0	0
2	S2	27	Conc2500NW	0	0
3	S3	27	Conc2500NW	0	0
4	S4	27	Conc2500NW	0	0
5	S5	27	Conc2500NW	0	0
6	S6	27	Conc2500NW	0	0

**Load Combinations**

	Label	Solve	Service A	SF	Cat..Fa...	Cat..Fa...	Cat..Fa...	Cat..Fa...	Cat..Fa...	Cat..Fa...	Cat..Fa...	Cat..Fa...	C...	F...	C...	F...
1	1.0 D	Yes	Yes	1.5	DL	1										
2	1.0 D + 1....	Yes	Yes	1.5	DL	1	RLL	1								

### Load Combinations (Continued)

Label	Solve	Service	A..SF	Cat..Fa...	Cat..Fa...	Cat..Fa...	Cat..Fa...	Cat..Fa...	Cat..Fa...	Cat..Fa...	Cat..Fa...	Cat..Fa...	C...	F...	C...	F...
3	1.0 D + 0...	Yes	Yes	1.5	DL	1	RLL		OL1	.6						
4	1.0 D + 0...	Yes	Yes	1.5	DL	1	RLL		OL2	.6						
5	1.0 D + 0...	Yes	Yes	1.5	DL	1	RLL		OL3	.6						
6	1.0 D + 0...	Yes	Yes	1.5	DL	1	RLL		OL4	.6						
7	1.0 D + 0...	Yes	Yes	1.5	DL	1	RLL		OL5	.6						
8	1.0 D + 0...	Yes	Yes	1.5	DL	1	RLL		OL6	.6						
9	1.0 D + 0...	Yes	Yes	1.5	DL	1	RLL	.75	OL1	.45						
10	1.0 D + 0...	Yes	Yes	1.5	DL	1	RLL	.75	OL2	.45						
11	1.0 D + 0...	Yes	Yes	1.5	DL	1	RLL	.75	OL3	.45						
12	1.0 D + 0...	Yes	Yes	1.5	DL	1	RLL	.75	OL4	.45						
13	1.0 D + 0...	Yes	Yes	1.5	DL	1	RLL	.75	OL5	.45						
14	1.0 D + 0...	Yes	Yes	1.5	DL	1	RLL	.75	OL6	.45						
15	0.6 D + 0...	Yes	Yes		DL	.6	RLL		OL1	.6						
16	0.6 D + 0...	Yes	Yes		DL	.6	RLL		OL2	.6						
17	0.6 D + 0...	Yes	Yes		DL	.6	RLL		OL3	.6						
18	0.6 D + 0...	Yes	Yes		DL	.6	RLL		OL4	.6						
19	0.6 D + 0...	Yes	Yes		DL	.6	RLL		OL5	.6						
20	0.6 D + 0...	Yes	Yes		DL	.6	RLL		OL6	.6						
21																
22	1.4D	Yes			DL	1.4										
23	1.2D+1.6SL	Yes			DL	1.2	RLL	1.6								
24	1.2D+1.6S...	Yes			DL	1.2	RLL	1.6	OL1	.5						
25	1.2D+1.6S...	Yes			DL	1.2	RLL	1.6	OL2	.5						
26	1.2D+1.6S...	Yes			DL	1.2	RLL	1.6	OL3	.5						
27	1.2D+1.6S...	Yes			DL	1.2	RLL	1.6	OL4	.5						
28	1.2D+1.6S...	Yes			DL	1.2	RLL	1.6	OL5	.5						
29	1.2D+1.6S...	Yes			DL	1.2	RLL	1.6	OL6	.5						
30	1.2D+1.0...	Yes			DL	1.2			OL1	1						
31	1.2D-1.0Wx	Yes			DL	1.2			OL2	1						
32	1.2D+1.0...	Yes			DL	1.2			OL3	1						
33	1.2D-1.0Wz	Yes			DL	1.2			OL4	1						
34	1.2D+1.0...	Yes			DL	1.2			OL5	1						
35	1.2D-1.0...	Yes			DL	1.2			OL6	1						
36	.9D+1.0Wx	Yes			DL	.9			OL1	1						
37	.9D-1.0Wx	Yes			DL	.9			OL2	1						
38	.9D+1.0Wz	Yes			DL	.9			OL3	1						
39	.9D-1.0Wz	Yes			DL	.9			OL4	1						
40	.9D+1.0W...	Yes			DL	.9			OL5	1						
41	.9D-1.0W90	Yes			DL	.9			OL6	1						

### Design Strips

	Label	Rebar Angle from Pl...	No. of Design Cuts	Design Rule
1	DS1	0	50	Typical
2	DS2	90	50	Typical

### Load Categories

	Category	Point Loads	Line Loads	Area Loads
1	DL	19		
2	RLL	23		
3	OL1	36		
4	OL2	36		
5	OL3	36		
6	OL4	35		
7	OL5	34		
8	OL6	34		





**Strip Reinforcing**

	Label	UC Top	LC	Top Bars	Governing ...	UC Bot	LC	Bot B...	Gover...	UC Shear	LC	Governing ...
1	DS1	.023	26	#5@10in	DS1-X25	.043	37	#5@1...	DS1-...	.041	37	DS1-X15
2	DS2	.002	36	#5@10in	DS2-X26	.003	26	#5@1...	DS2-...	.005	26	DS2-X25

**Slab Overturning Safety Factors (By Combination)**

	LC	Slab	Angle[deg]	Mo-xx[lb-ft]	Ms-xx[lb-ft]	Mo-zz[lb-ft]	Ms-zz[lb-ft]	Ms-xx/Mo-xx	Ms-zz/Mo-zz
1	1	S1	0	0	40813.277	0	10669.394	9.999+	9.999+
2	1	S2	0	0	41695.811	0	10740.533	9.999+	9.999+
3	1	S3	0	0	41575.768	0	10744.24	9.999+	9.999+
4	1	S4	0	0	41575.695	0	10744.136	9.999+	9.999+
5	1	S5	0	0	41697.594	0	10749.35	9.999+	9.999+
6	1	S6	0	0	40802.088	0	10448.162	9.999+	9.999+
7	2	S1	0	0	46332.325	0	12604.113	9.999+	9.999+
8	2	S2	0	0	49914.059	0	12925.535	9.999+	9.999+
9	2	S3	0	0	49421.468	0	12936.418	9.999+	9.999+
10	2	S4	0	0	49421.3	0	12946.448	9.999+	9.999+
11	2	S5	0	0	49921.206	0	12953.271	9.999+	9.999+
12	2	S6	0	0	46288.295	0	11729.929	9.999+	9.999+
13	3	S1	0	15305.182	40991.057	2809.333	10669.394	2.678	3.798
14	3	S2	0	22179.661	41365.611	3141.772	10740.533	1.865	3.419
15	3	S3	0	21466.779	41491.847	3158.832	10744.24	1.933	3.401
16	3	S4	0	21473.243	41491.207	3165.772	10744.136	1.932	3.394
17	3	S5	0	22197.157	41368.062	3173.344	10749.35	1.864	3.387
18	3	S6	0	15215.201	40980.411	2254.133	10521.674	2.693	4.668
19	4	S1	0	16630.952	40991.057	2506.651	10669.394	2.465	4.256
20	4	S2	0	23252.278	41365.611	2566.413	10740.533	1.779	4.185
21	4	S3	0	22943.9	41491.847	2659.851	10744.24	1.808	4.039
22	4	S4	0	22953.288	41491.207	2665.946	10744.136	1.808	4.03
23	4	S5	0	23268.928	41368.062	2547.721	10749.35	1.778	4.219
24	4	S6	0	16535.938	40980.411	2022.268	10521.674	2.478	5.203
25	5	S1	0	0	41637.093	0	13946.95	9.999+	9.999+
26	5	S2	0	540.543	41695.811	0	14405.933	9.999+	9.999+
27	5	S3	0	0	41920.758	0	14429.543	9.999+	9.999+
28	5	S4	0	0	41910.104	0	14437.537	9.999+	9.999+
29	5	S5	0	538.523	41697.594	0	14451.585	9.999+	9.999+
30	5	S6	0	0	41623.188	0	12580.427	9.999+	9.999+
31	6	S1	0	0	44137.41	0	13345.722	9.999+	9.999+
32	6	S2	0	0	45474.998	0	13923.867	9.999+	9.999+
33	6	S3	0	0	45779.082	0	13880.983	9.999+	9.999+
34	6	S4	0	0	45773.695	0	13888.561	9.999+	9.999+
35	6	S5	0	0	45478.823	0	14000.416	9.999+	9.999+
36	6	S6	0	0	44108.651	0	12264.223	9.999+	9.999+
37	7	S1	0	0	41020.177	0	11834.326	9.999+	9.999+
38	7	S2	0	173.942	41695.811	0	11709.715	9.999+	9.999+
39	7	S3	0	0	41672.249	0	11253.083	9.999+	9.999+
40	7	S4	0	0	41618.883	0	11268.052	9.999+	9.999+
41	7	S5	0	97.441	41697.594	0	11249.887	9.999+	9.999+
42	7	S6	0	0	40930.676	0	10748.157	9.999+	9.999+
43	8	S1	0	6574.819	40991.057	1135.122	10669.394	6.235	9.399
44	8	S2	0	6186.62	41365.611	842.76	10740.533	6.686	9.999+
45	8	S3	0	3419.721	41491.847	505.482	10744.24	9.999+	9.999+
46	8	S4	0	3617.708	41491.207	525.047	10744.136	9.999+	9.999+
47	8	S5	0	3613.329	41368.062	503.311	10749.35	9.999+	9.999+
48	8	S6	0	2635.857	40980.411	407.344	10521.674	9.999+	9.999+
49	9	S1	0	11478.886	45182.041	2107	12120.433	3.936	5.752
50	9	S2	0	16634.746	46521.667	2356.329	12379.284	2.797	5.254
51	9	S3	0	16100.084	46942.299	2369.124	12388.374	2.916	5.229



**Slab Overturning Safety Factors (By Combination) (Continued)**

LC	Slab	Angle[deg]	Mo-xx[lb-ft]	Ms-xx[lb-ft]	Mo-zz[lb-ft]	Ms-zz[lb-ft]	Ms-xx/Mo-xx	Ms-zz/Mo-zz	
52	9	S4	0	16104.932	46940.295	2374.329	12395.87	2.915	5.221
53	9	S5	0	16647.868	46529.528	2380.008	12402.291	2.795	5.211
54	9	S6	0	11411.401	45148.08	1690.6	11684.018	3.956	6.911
55	10	S1	0	12473.214	45182.041	1879.988	12120.433	3.622	6.447
56	10	S2	0	17439.208	46521.667	1924.81	12379.284	2.668	6.431
57	10	S3	0	17207.925	46942.299	1994.889	12388.374	2.728	6.21
58	10	S4	0	17214.966	46940.295	1999.46	12395.87	2.727	6.2
59	10	S5	0	17451.696	46529.528	1910.791	12402.291	2.666	6.491
60	10	S6	0	12401.953	45148.08	1516.701	11684.018	3.64	7.704
61	11	S1	0	0	45570.425	0	14578.6	9.999+	9.999+
62	11	S2	0	405.407	47859.497	0	15128.334	9.999+	9.999+
63	11	S3	0	0	47718.785	0	15152.351	9.999+	9.999+
64	11	S4	0	0	47710.705	0	15165.921	9.999+	9.999+
65	11	S5	0	403.892	47865.303	0	15178.967	9.999+	9.999+
66	11	S6	0	0	45532.569	0	13008.686	9.999+	9.999+
67	12	S1	0	0	47445.663	0	14127.679	9.999+	9.999+
68	12	S2	0	0	50693.888	0	14766.785	9.999+	9.999+
69	12	S3	0	0	50612.528	0	14740.931	9.999+	9.999+
70	12	S4	0	0	50608.398	0	14754.189	9.999+	9.999+
71	12	S5	0	0	50701.225	0	14840.59	9.999+	9.999+
72	12	S6	0	0	47396.666	0	12771.533	9.999+	9.999+
73	13	S1	0	0	45107.737	0	12994.133	9.999+	9.999+
74	13	S2	0	130.456	47859.497	0	13106.171	9.999+	9.999+
75	13	S3	0	0	47532.404	0	12770.006	9.999+	9.999+
76	13	S4	0	0	47492.29	0	12788.807	9.999+	9.999+
77	13	S5	0	73.081	47865.303	0	12777.693	9.999+	9.999+
78	13	S6	0	0	45013.184	0	11634.483	9.999+	9.999+
79	14	S1	0	4931.114	45182.041	851.342	12120.433	9.163	9.999+
80	14	S2	0	4639.965	46521.667	632.07	12379.284	9.999+	9.999+
81	14	S3	0	2564.791	46942.299	379.111	12388.374	9.999+	9.999+
82	14	S4	0	2713.281	46940.295	393.786	12395.87	9.999+	9.999+
83	14	S5	0	2709.996	46529.528	377.483	12402.291	9.999+	9.999+
84	14	S6	0	1976.893	45148.08	305.508	11684.018	9.999+	9.999+
85	15	S1	0	15305.182	24594.634	2809.333	6401.636	1.607	2.279
86	15	S2	0	22179.661	24819.366	3141.772	6444.32	1.119	2.051
87	15	S3	0	21466.779	24895.108	3158.832	6446.544	1.16	2.041
88	15	S4	0	21473.243	24894.724	3165.772	6446.482	1.159	2.036
89	15	S5	0	22197.157	24820.837	3173.344	6449.61	1.118	2.032
90	15	S6	0	15215.201	24588.247	2254.133	6313.004	1.616	2.801
91	16	S1	0	16630.952	24594.634	2506.651	6401.636	1.479	2.554
92	16	S2	0	23252.278	24819.366	2566.413	6444.32	1.067	2.511
93	16	S3	0	22943.9	24895.108	2659.851	6446.544	1.085	2.424
94	16	S4	0	22953.288	24894.724	2665.946	6446.482	1.085	2.418
95	16	S5	0	23268.928	24820.837	2547.721	6449.61	1.067	2.532
96	16	S6	0	16535.938	24588.247	2022.268	6313.004	1.487	3.122
97	17	S1	0	0	25311.782	0	9679.192	9.999+	9.999+
98	17	S2	0	540.543	25017.487	0	10109.72	9.999+	9.999+
99	17	S3	0	0	25290.45	0	10131.847	9.999+	9.999+
100	17	S4	0	0	25279.826	0	10139.882	9.999+	9.999+
101	17	S5	0	538.523	25018.556	0	10151.845	9.999+	9.999+
102	17	S6	0	0	25302.353	0	8401.162	9.999+	9.999+
103	18	S1	0	0	27812.1	0	9077.964	9.999+	9.999+
104	18	S2	0	0	28796.674	0	9627.654	9.999+	9.999+
105	18	S3	0	0	29148.775	0	9583.287	9.999+	9.999+
106	18	S4	0	0	29143.417	0	9590.907	9.999+	9.999+
107	18	S5	0	0	28799.785	0	9700.676	9.999+	9.999+
108	18	S6	0	0	27787.816	0	8084.958	9.999+	9.999+

**Slab Overturning Safety Factors (By Combination) (Continued)**

	LC	Slab	Angle[deg]	Mo-xx[lb-ft]	Ms-xx[lb-ft]	Mo-zz[lb-ft]	Ms-zz[lb-ft]	Ms-xx/Mo-xx	Ms-zz/Mo-zz
109	19	S1	0	0	24694.866	0	7566.569	9.999+	9.999+
110	19	S2	0	173.942	25017.487	0	7413.502	9.999+	9.999+
111	19	S3	0	0	25041.942	0	6955.387	9.999+	9.999+
112	19	S4	0	0	24988.605	0	6970.397	9.999+	9.999+
113	19	S5	0	97.441	25018.556	0	6950.146	9.999+	9.999+
114	19	S6	0	0	24609.84	0	6568.892	9.999+	9.999+
115	20	S1	0	6574.819	24594.634	1135.122	6401.636	3.741	5.64
116	20	S2	0	6186.62	24819.366	842.76	6444.32	4.012	7.647
117	20	S3	0	3419.721	24895.108	505.482	6446.544	7.28	9.999+
118	20	S4	0	3617.708	24894.724	525.047	6446.482	6.881	9.999+
119	20	S5	0	3613.329	24820.837	503.311	6449.61	6.869	9.999+
120	20	S6	0	2635.857	24588.247	407.344	6313.004	9.328	9.999+

**Slab Sliding Safety Factors (By Combination)**

	LC	Slab	Angle[deg]	Va-xx[lb]	Vr-xx[lb]	Va-zz[lb]	Vr-zz[lb]	SR-xx	SR-zz
1	1	S1	0	48.314	2517.052	0	2517.052	9.999+	9.999+
2	1	S2	0	1.248	2555.732	0	2555.732	9.999+	9.999+
3	1	S3	0	0	2555.922	0	2555.922	9.999+	9.999+
4	1	S4	0	0	2555.9	0	2555.9	9.999+	9.999+
5	1	S5	0	2.398	2555.862	0	2555.862	9.999+	9.999+
6	1	S6	0	48.601	2516.38	0	2516.38	9.999+	9.999+
7	2	S1	0	190.928	2858.806	0	2858.806	9.999+	9.999+
8	2	S2	0	4.8	3020.131	0	3020.131	9.999+	9.999+
9	2	S3	0	1.653	3020.936	0	3020.936	9.999+	9.999+
10	2	S4	0	2.974	3020.855	0	3020.855	9.999+	9.999+
11	2	S5	0	6.442	3020.648	0	3020.648	9.999+	9.999+
12	2	S6	0	192.06	2856.167	0	2856.167	9.999+	9.999+
13	3	S1	0	166.311	2024.397	841.297	2024.397	9.999+	2.406
14	3	S2	0	4.792	1887.538	1417.526	1887.538	9.999+	1.332
15	3	S3	0	1.437	1886.309	1263.792	1886.309	9.999+	1.493
16	3	S4	0	1.816	1886.367	1264.516	1886.367	9.999+	1.492
17	3	S5	0	4.353	1887.076	1418.507	1887.076	9.999+	1.33
18	3	S6	0	167.114	2026.566	835.786	2026.566	9.999+	2.425
19	4	S1	0	164.188	2087.483	704.94	2087.483	9.999+	2.961
20	4	S2	0	6.224	2014.627	1189.38	2014.627	9.999+	1.694
21	4	S3	0	1.345	1992.019	1058.815	1992.019	9.999+	1.881
22	4	S4	0	1.548	1992.084	1059.912	1992.084	9.999+	1.879
23	4	S5	0	6.873	2014.212	1189.879	2014.212	9.999+	1.693
24	4	S6	0	164.605	2089.211	700.422	2089.211	9.999+	2.983
25	5	S1	0	298.711	3091.816	981.514	3091.816	9.999+	3.15
26	5	S2	0	8.294	3335.291	1653.781	3335.291	9.999+	2.017
27	5	S3	0	1.677	3337.138	1474.424	3337.138	9.999+	2.263
28	5	S4	0	2.118	3337.023	1475.268	3337.023	9.999+	2.262
29	5	S5	0	10.274	3336.112	1654.925	3336.112	9.999+	2.016
30	5	S6	0	300.268	3087.831	975.084	3087.831	9.999+	3.167
31	6	S1	0	235.905	2994.422	838.197	2994.422	9.999+	3.572
32	6	S2	0	15.329	3236.559	1411.012	3236.559	9.999+	2.294
33	6	S3	0	1.319	3220.802	1259.248	3220.802	9.999+	2.558
34	6	S4	0	2.229	3220.716	1259.575	3220.716	9.999+	2.557
35	6	S5	0	17.265	3237.239	1412.248	3237.239	9.999+	2.292
36	6	S6	0	237.445	2990.937	832.626	2990.937	9.999+	3.592
37	7	S1	0	120.075	2729.552	375.906	2729.552	9.999+	7.261
38	7	S2	0	17.084	2768.516	453.549	2768.516	9.999+	6.104
39	7	S3	0	2.731	2664.979	199.648	2664.979	9.999+	9.999+
40	7	S4	0	3.271	2668.406	212.484	2668.406	9.999+	9.999+
41	7	S5	0	1.503	2663.717	235.686	2663.717	9.999+	9.999+



**Slab Sliding Safety Factors (By Combination) (Continued)**

	LC	Slab	Angle[deg]	Va-xx[lb]	Vr-xx[lb]	Va-zz[lb]	Vr-zz[lb]	SR-xx	SR-zz
42	7	S6	0	94.562	2601.808	139.653	2601.808	9.999+	9.999+
43	8	S1	0	18.617	2308.564	369.999	2308.564	9.999+	6.239
44	8	S2	0	12.923	2370.513	398.123	2370.513	9.999+	5.954
45	8	S3	0	2.309	2447.779	198.101	2447.779	9.999+	9.999+
46	8	S4	0	2.918	2443.323	212.947	2443.323	9.999+	9.999+
47	8	S5	0	5.898	2447.611	235.584	2447.611	9.999+	9.999+
48	8	S6	0	3.938	2431.406	139.669	2431.406	9.999+	9.999+
49	9	S1	0	5.695	2403.877	630.973	2403.877	9.999+	3.81
50	9	S2	0	.617	2402.885	1063.145	2402.885	9.999+	2.26
51	9	S3	0	.162	2402.472	947.844	2402.472	9.999+	2.535
52	9	S4	0	.869	2402.466	948.387	2402.466	9.999+	2.533
53	9	S5	0	.367	2402.862	1063.88	2402.862	9.999+	2.259
54	9	S6	0	5.591	2403.86	626.84	2403.86	9.999+	3.835
55	10	S1	0	4.103	2451.191	528.705	2451.191	9.999+	4.636
56	10	S2	0	7.644	2498.202	892.035	2498.202	9.999+	2.801
57	10	S3	0	.231	2481.755	794.111	2481.755	9.999+	3.125
58	10	S4	0	1.07	2481.754	794.934	2481.754	9.999+	3.122
59	10	S5	0	8.787	2498.214	892.409	2498.214	9.999+	2.799
60	10	S6	0	3.709	2450.844	525.317	2450.844	9.999+	4.665
61	11	S1	0	343.072	3204.441	736.135	3204.441	9.34	4.353
62	11	S2	0	9.196	3488.701	1240.335	3488.701	9.999+	2.813
63	11	S3	0	2.497	3490.595	1105.818	3490.595	9.999+	3.157
64	11	S4	0	3.82	3490.458	1106.451	3490.458	9.999+	3.155
65	11	S5	0	11.338	3489.639	1241.193	3489.639	9.999+	2.812
66	11	S6	0	344.946	3199.808	731.313	3199.808	9.276	4.375
67	12	S1	0	295.967	3131.395	628.648	3131.395	9.999+	4.981
68	12	S2	0	14.473	3414.651	1058.259	3414.651	9.999+	3.227
69	12	S3	0	2.229	3403.342	944.436	3403.342	9.999+	3.604
70	12	S4	0	3.902	3403.228	944.681	3403.228	9.999+	3.603
71	12	S5	0	16.581	3415.484	1059.186	3415.484	9.999+	3.225
72	12	S6	0	297.828	3127.138	624.469	3127.138	9.999+	5.008
73	13	S1	0	209.095	2932.742	281.93	2932.742	9.999+	9.999+
74	13	S2	0	15.789	3063.619	340.161	3063.619	9.999+	9.006
75	13	S3	0	3.288	2986.475	149.736	2986.475	9.999+	9.999+
76	13	S4	0	.222	2988.995	159.363	2988.995	9.999+	9.999+
77	13	S5	0	2.505	2985.342	176.764	2985.342	9.999+	9.999+
78	13	S6	0	190.666	2835.291	104.74	2835.291	9.999+	9.999+
79	14	S1	0	105.076	2617.002	277.499	2617.002	9.999+	9.431
80	14	S2	0	6.716	2765.117	298.593	2765.117	9.999+	9.261
81	14	S3	0	.492	2823.575	148.576	2823.575	9.999+	9.999+
82	14	S4	0	4.42	2820.184	159.71	2820.184	9.999+	9.999+
83	14	S5	0	8.056	2823.263	176.688	2823.263	9.999+	9.999+
84	14	S6	0	122.698	2707.49	104.752	2707.49	9.999+	9.999+
85	15	S1	0	185.637	1017.576	841.297	1017.576	5.482	1.21
86	15	S2	0	5.291	865.245	1417.526	865.245	9.999+	.61
87	15	S3	0	1.437	863.94	1263.792	863.94	9.999+	.684
88	15	S4	0	1.816	864.007	1264.516	864.007	9.999+	.683
89	15	S5	0	5.312	864.732	1418.507	864.732	9.999+	.61
90	15	S6	0	186.554	1020.014	835.786	1020.014	5.468	1.22
91	16	S1	0	183.514	1080.662	704.94	1080.662	5.889	1.533
92	16	S2	0	5.725	992.334	1189.38	992.334	9.999+	.834
93	16	S3	0	1.345	969.65	1058.815	969.65	9.999+	.916
94	16	S4	0	1.548	969.724	1059.912	969.724	9.999+	.915
95	16	S5	0	5.913	991.868	1189.879	991.868	9.999+	.834
96	16	S6	0	184.045	1082.659	700.422	1082.659	5.883	1.546
97	17	S1	0	279.385	2084.995	981.514	2084.995	7.463	2.124
98	17	S2	0	7.794	2312.999	1653.781	2312.999	9.999+	1.399

**Slab Sliding Safety Factors (By Combination) (Continued)**

	LC	Slab	Angle[deg]	Va-xx[lb]	Vr-xx[lb]	Va-zz[lb]	Vr-zz[lb]	SR-xx	SR-zz
99	17	S3	0	1.677	2314.769	1474.424	2314.769	9.999+	1.57
100	17	S4	0	2.118	2314.663	1475.268	2314.663	9.999+	1.569
101	17	S5	0	9.315	2313.767	1654.925	2313.767	9.999+	1.398
102	17	S6	0	280.828	2081.279	975.084	2081.279	7.411	2.134
103	18	S1	0	216.579	1987.602	838.197	1987.602	9.177	2.371
104	18	S2	0	14.83	2214.266	1411.012	2214.266	9.999+	1.569
105	18	S3	0	1.319	2198.433	1259.248	2198.433	9.999+	1.746
106	18	S4	0	2.229	2198.356	1259.575	2198.356	9.999+	1.745
107	18	S5	0	16.306	2214.894	1412.248	2214.894	9.999+	1.568
108	18	S6	0	218.005	1984.384	832.626	1984.384	9.102	2.383
109	19	S1	0	100.749	1722.731	375.906	1722.731	9.999+	4.583
110	19	S2	0	16.585	1746.223	453.549	1746.223	9.999+	3.85
111	19	S3	0	2.731	1642.61	199.648	1642.61	9.999+	8.228
112	19	S4	0	3.271	1646.045	212.484	1646.045	9.999+	7.747
113	19	S5	0	2.462	1641.372	235.686	1641.372	9.999+	6.964
114	19	S6	0	75.122	1595.256	139.653	1595.256	9.999+	9.999+
115	20	S1	0	37.943	1301.743	369.999	1301.743	9.999+	3.518
116	20	S2	0	13.422	1348.22	398.123	1348.22	9.999+	3.386
117	20	S3	0	2.309	1425.41	198.101	1425.41	9.999+	7.195
118	20	S4	0	2.918	1420.963	212.947	1420.963	9.999+	6.673
119	20	S5	0	4.939	1425.266	235.584	1425.266	9.999+	6.05
120	20	S6	0	15.503	1424.854	139.669	1424.854	9.999+	9.999+

**Envelope Slab Soil Pressures**

	Label	UC	LC	Soil Pressure[psf]	Allowable Bearing[psf]	Point
1	S1	.405	5	607.583	1500	N1
2	S2	.482	5	722.419	1500	N16
3	S3	.476	5	714.522	1500	N20
4	S4	.476	5	714.672	1500	N24
5	S5	.482	5	722.734	1500	N28
6	S6	.404	5	605.988	1500	N34



Company:		Date:	5/14/2018
Engineer:		Page:	1/6
Project:			
Address:			
Phone:			
E-mail:			

**1. Project information**

Customer company:  
Customer contact name:  
Customer e-mail:  
Comment:

Project description:  
Location:  
Fastening description:

**2. Input Data & Anchor Parameters**

**General**

Design method: ACI 318-14  
Units: Imperial units

**Anchor Information:**

Anchor type: Bonded anchor  
Material: F1554 Grade 36  
Diameter (inch): 0.375  
Effective Embedment depth,  $h_{ef}$  (inch): 4.000  
Code report: ICC-ES ESR-4057  
Anchor category: -  
Anchor ductility: Yes  
 $h_{min}$  (inch): 5.25  
 $c_{ac}$  (inch): 7.12  
 $c_{min}$  (inch): 1.75  
 $s_{min}$  (inch): 3.00

**Base Material**

Concrete: Normal-weight  
Concrete thickness,  $h$  (inch): 24.00  
State: Cracked  
Compressive strength,  $f'_c$  (psi): 2500  
 $\Psi_{c,v}$ : 1.0  
Reinforcement condition: B tension, B shear  
Supplemental reinforcement: Not applicable  
Reinforcement provided at corners: No  
Ignore concrete breakout in tension: No  
Ignore concrete breakout in shear: No  
Hole condition: Dry concrete  
Inspection: Periodic  
Temperature range, Short/Long: 150/110°F  
Ignore 6do requirement: Not applicable  
Build-up grout pad: No

**Base Plate**

Length x Width x Thickness (inch): 4.75 x 4.75 x 0.31

**Recommended Anchor**

Anchor Name: SET-3G - SET-3G w/ 3/8"Ø F1554 Gr. 36  
Code Report: ICC-ES ESR-4057





Company:		Date:	5/14/2018
Engineer:		Page:	2/6
Project:			
Address:			
Phone:			
E-mail:			

**Load and Geometry**

Load factor source: ACI 318 Section 5.3

Load combination: not set

Seismic design: No

Anchors subjected to sustained tension: No

Apply entire shear load at front row: No

Anchors only resisting wind and/or seismic loads: No

Strength level loads:

$N_{ua}$  [lb]: 4000

$V_{uax}$  [lb]: 525

$V_{uay}$  [lb]: -2850

$M_{ux}$  [ft-lb]: 0

$M_{uy}$  [ft-lb]: 0

$M_{uz}$  [ft-lb]: 0

<Figure 1>

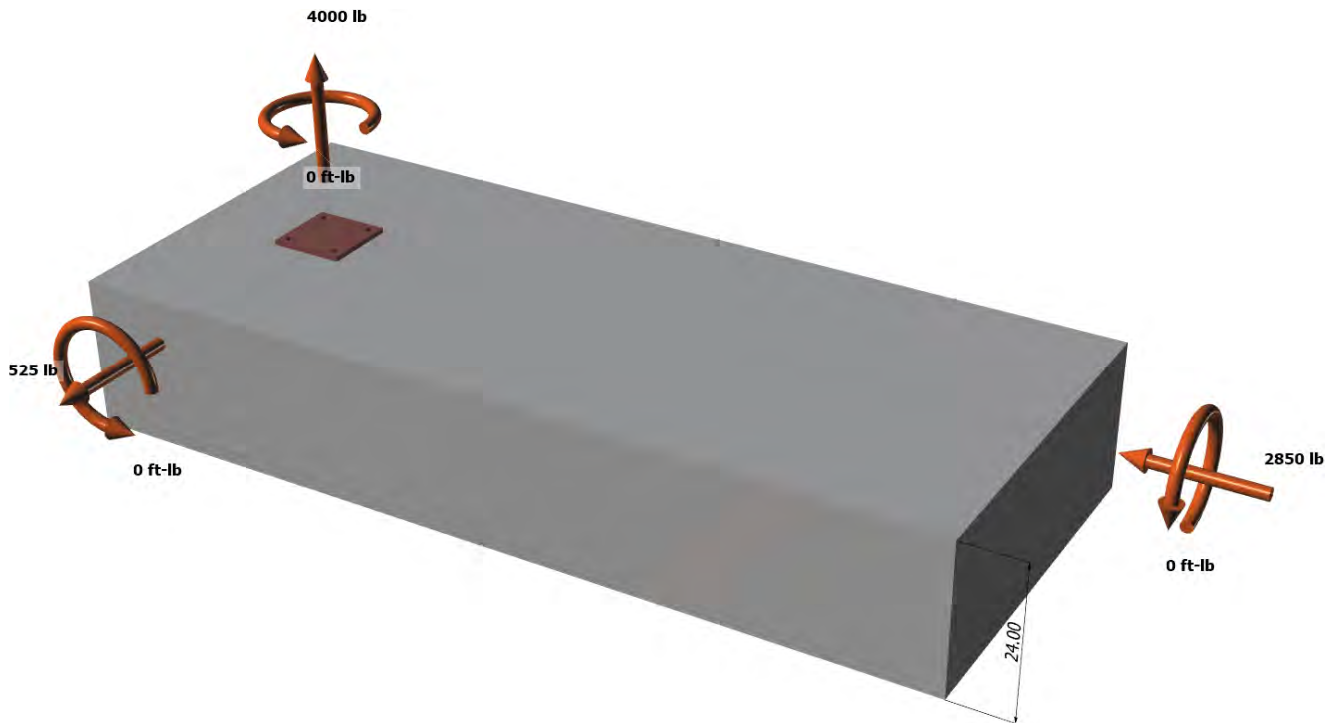



Company:		Date:	5/14/2018
Engineer:		Page:	3/6
Project:			
Address:			
Phone:			
E-mail:			

<Figure 2>

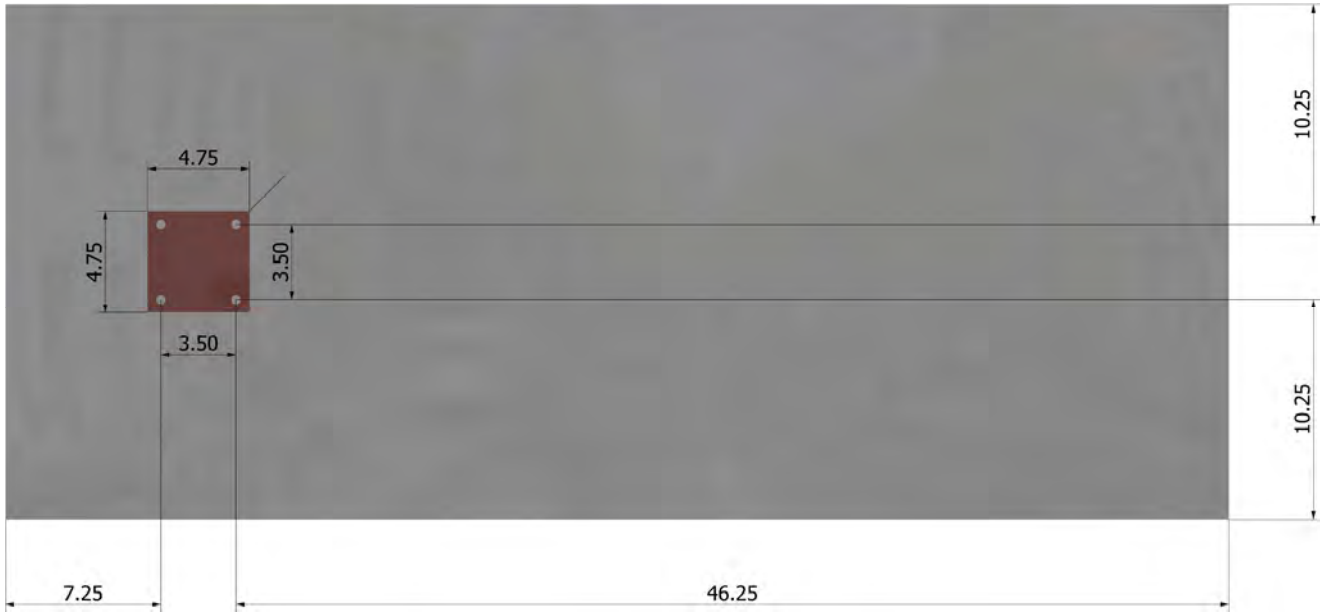





Company:		Date:	5/14/2018
Engineer:		Page:	4/6
Project:			
Address:			
Phone:			
E-mail:			

### 3. Resulting Anchor Forces

Anchor	Tension load, N <sub>ua</sub> (lb)	Shear load x, V <sub>uax</sub> (lb)	Shear load y, V <sub>uay</sub> (lb)	Shear load combined, $\sqrt{(V_{uax})^2 + (V_{uay})^2}$ (lb)
1	1000.0	131.3	-712.5	724.5
2	1000.0	131.3	-712.5	724.5
3	1000.0	131.3	-712.5	724.5
4	1000.0	131.3	-712.5	724.5
Sum	4000.0	525.0	-2850.0	2898.0

Maximum concrete compression strain (%): 0.00  
 Maximum concrete compression stress (psi): 0  
 Resultant tension force (lb): 4000  
 Resultant compression force (lb): 0  
 Eccentricity of resultant tension forces in x-axis, e'<sub>Nx</sub> (inch): 0.00  
 Eccentricity of resultant tension forces in y-axis, e'<sub>Ny</sub> (inch): 0.00  
 Eccentricity of resultant shear forces in x-axis, e'<sub>Vx</sub> (inch): 0.00  
 Eccentricity of resultant shear forces in y-axis, e'<sub>Vy</sub> (inch): 0.00

<Figure 3>

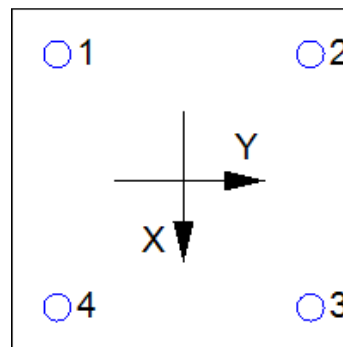

### 4. Steel Strength of Anchor in Tension (Sec. 17.4.1)

N <sub>sa</sub> (lb)	φ	φN <sub>sa</sub> (lb)
4525	0.75	3394

### 5. Concrete Breakout Strength of Anchor in Tension (Sec. 17.4.2)

$$N_b = K_c \lambda_a \sqrt{f_c} h_{ef}^{1.5} \text{ (Eq. 17.4.2.2a)}$$

K <sub>c</sub>	λ <sub>a</sub>	f <sub>c</sub> (psi)	h <sub>ef</sub> (in)	N <sub>b</sub> (lb)
17.0	1.00	2500	4.000	6800

$$\phi N_{cbg} = \phi (A_{Nc} / A_{Nco}) \psi_{ec,N} \psi_{ed,N} \psi_{c,N} \psi_{cp,N} N_b \text{ (Sec. 17.3.1 \& Eq. 17.4.2.1b)}$$

A <sub>Nc</sub> (in <sup>2</sup> )	A <sub>Nco</sub> (in <sup>2</sup> )	c <sub>a,min</sub> (in)	ψ <sub>ec,N</sub>	ψ <sub>ed,N</sub>	ψ <sub>c,N</sub>	ψ <sub>cp,N</sub>	N <sub>b</sub> (lb)	φ	φN <sub>cbg</sub> (lb)
240.25	144.00	7.25	1.000	1.000	1.00	1.000	6800	0.65	7374

### 6. Adhesive Strength of Anchor in Tension (Sec. 17.4.5)

$$\tau_{k,cr} = \tau_{k,cr,short-term} K_{sat} (f_c / 2,500)^n$$

τ <sub>k,cr</sub> (psi)	f <sub>short-term</sub>	K <sub>sat</sub>	f <sub>c</sub> (psi)	n	τ <sub>k,cr</sub> (psi)
1346	1.00	1.00	2500	0.24	1346

$$N_{ba} = \lambda_a \tau_{cr} \pi d_a h_{ef} \text{ (Eq. 17.4.5.2)}$$

λ <sub>a</sub>	τ <sub>cr</sub> (psi)	d <sub>a</sub> (in)	h <sub>ef</sub> (in)	N <sub>ba</sub> (lb)
1.00	1346	0.38	4.000	6343

$$\phi N_{ag} = \phi (A_{Na} / A_{Na0}) \psi_{ec,Na} \psi_{ed,Na} \psi_{cp,Na} N_{ba} \text{ (Sec. 17.3.1 \& Eq. 17.4.5.1b)}$$

A <sub>Na</sub> (in <sup>2</sup> )	A <sub>Na0</sub> (in <sup>2</sup> )	c <sub>Na</sub> (in)	c <sub>a,min</sub> (in)	ψ <sub>ec,Na</sub>	ψ <sub>ed,Na</sub>	ψ <sub>cp,Na</sub>	N <sub>ba</sub> (lb)	φ	φN <sub>ag</sub> (lb)
198.45	112.09	5.29	7.25	1.000	1.000	1.000	6343	0.55	6176



Company:		Date:	5/14/2018
Engineer:		Page:	5/6
Project:			
Address:			
Phone:			
E-mail:			

**8. Steel Strength of Anchor in Shear (Sec. 17.5.1)**

$V_{sa}$ (lb)	$\phi_{grout}$	$\phi$	$\phi_{grout}\phi V_{sa}$ (lb)
2715	1.0	0.65	1765

**9. Concrete Breakout Strength of Anchor in Shear (Sec. 17.5.2)**

**Shear perpendicular to edge in x-direction:**

$V_{bx} = \min|7(l_e / d_a)^{0.2} \sqrt{d_a} \lambda_a \sqrt{f_c} c_{a1}^{1.5}; 9 \lambda_a \sqrt{f_c} c_{a1}^{1.5}|$  (Eq. 17.5.2.2a & Eq. 17.5.2.2b)

$l_e$ (in)	$d_a$ (in)	$\lambda_a$	$f_c$ (psi)	$c_{a1}$ (in)	$V_{bx}$ (lb)
3.00	0.375	1.00	2500	13.75	16564

$\phi V_{cbgx} = \phi (A_{Vc} / A_{Vco}) \psi_{ec,v} \psi_{ed,v} \psi_{c,v} \psi_{h,v} V_{bx}$  (Sec. 17.3.1 & Eq. 17.5.2.1b)

$A_{Vc}$ (in <sup>2</sup> )	$A_{Vco}$ (in <sup>2</sup> )	$\psi_{ec,v}$	$\psi_{ed,v}$	$\psi_{c,v}$	$\psi_{h,v}$	$V_{bx}$ (lb)	$\phi$	$\phi V_{cbgx}$ (lb)
647.11	850.78	1.000	0.805	1.000	1.000	16564	0.70	7103

**Shear perpendicular to edge in y-direction:**

$V_{by} = \min|7(l_e / d_a)^{0.2} \sqrt{d_a} \lambda_a \sqrt{f_c} c_{a1}^{1.5}; 9 \lambda_a \sqrt{f_c} c_{a1}^{1.5}|$  (Eq. 17.5.2.2a & Eq. 17.5.2.2b)

$l_e$ (in)	$d_a$ (in)	$\lambda_a$	$f_c$ (psi)	$c_{a1}$ (in)	$V_{by}$ (lb)
3.00	0.375	1.00	2500	10.75	11450

$\phi V_{cbgy} = \phi (A_{Vc} / A_{Vco}) \psi_{ec,v} \psi_{ed,v} \psi_{c,v} \psi_{h,v} V_{by}$  (Sec. 17.3.1 & Eq. 17.5.2.1b)

$A_{Vc}$ (in <sup>2</sup> )	$A_{Vco}$ (in <sup>2</sup> )	$\psi_{ec,v}$	$\psi_{ed,v}$	$\psi_{c,v}$	$\psi_{h,v}$	$V_{by}$ (lb)	$\phi$	$\phi V_{cbgy}$ (lb)
387.00	520.03	1.000	0.891	1.000	1.000	11450	0.70	5313

**Shear parallel to edge in x-direction:**

$V_{by} = \min|7(l_e / d_a)^{0.2} \sqrt{d_a} \lambda_a \sqrt{f_c} c_{a1}^{1.5}; 9 \lambda_a \sqrt{f_c} c_{a1}^{1.5}|$  (Eq. 17.5.2.2a & Eq. 17.5.2.2b)

$l_e$ (in)	$d_a$ (in)	$\lambda_a$	$f_c$ (psi)	$c_{a1}$ (in)	$V_{by}$ (lb)
3.00	0.375	1.00	2500	7.25	6342

$\phi V_{cbgx} = \phi (2)(A_{Vc} / A_{Vco}) \psi_{ec,v} \psi_{ed,v} \psi_{c,v} \psi_{h,v} V_{by}$  (Sec. 17.3.1, 17.5.2.1(c) & Eq. 17.5.2.1b)

$A_{Vc}$ (in <sup>2</sup> )	$A_{Vco}$ (in <sup>2</sup> )	$\psi_{ec,v}$	$\psi_{ed,v}$	$\psi_{c,v}$	$\psi_{h,v}$	$V_{by}$ (lb)	$\phi$	$\phi V_{cbgx}$ (lb)
261.00	236.53	1.000	1.000	1.000	1.000	6342	0.70	9797

**Shear parallel to edge in y-direction:**

$V_{bx} = \min|7(l_e / d_a)^{0.2} \sqrt{d_a} \lambda_a \sqrt{f_c} c_{a1}^{1.5}; 9 \lambda_a \sqrt{f_c} c_{a1}^{1.5}|$  (Eq. 17.5.2.2a & Eq. 17.5.2.2b)

$l_e$ (in)	$d_a$ (in)	$\lambda_a$	$f_c$ (psi)	$c_{a1}$ (in)	$V_{bx}$ (lb)
3.00	0.375	1.00	2500	10.25	10661

$\phi V_{cbgy} = \phi (2)(A_{Vc} / A_{Vco}) \psi_{ec,v} \psi_{ed,v} \psi_{c,v} \psi_{h,v} V_{bx}$  (Sec. 17.3.1, 17.5.2.1(c) & Eq. 17.5.2.1b)

$A_{Vc}$ (in <sup>2</sup> )	$A_{Vco}$ (in <sup>2</sup> )	$\psi_{ec,v}$	$\psi_{ed,v}$	$\psi_{c,v}$	$\psi_{h,v}$	$V_{bx}$ (lb)	$\phi$	$\phi V_{cbgy}$ (lb)
401.67	472.78	1.000	1.000	1.000	1.000	10661	0.70	12680

**10. Concrete Pryout Strength of Anchor in Shear (Sec. 17.5.3)**

$\phi V_{cp} = \phi \min|k_{cp} N_{ba}; k_{cp} N_{cbg}| = \phi \min|k_{cp}(A_{Na} / A_{Na0}) \psi_{ec,Na} \psi_{ed,Na} \psi_{cp,Na} N_{ba}; k_{cp}(A_{Nc} / A_{Nco}) \psi_{ec,N} \psi_{ed,N} \psi_{c,N} \psi_{cp,N} N_b|$  (Sec. 17.3.1 & Eq. 17.5.3.1b)

$k_{cp}$	$A_{Na}$ (in <sup>2</sup> )	$A_{Na0}$ (in <sup>2</sup> )	$\psi_{ed,Na}$	$\psi_{ec,Na}$	$\psi_{cp,Na}$	$N_{ba}$ (lb)	$N_a$ (lb)
2.0	198.45	112.09	1.000	1.000	1.000	6343	11230

$A_{Nc}$ (in <sup>2</sup> )	$A_{Nco}$ (in <sup>2</sup> )	$\psi_{ec,N}$	$\psi_{ed,N}$	$\psi_{c,N}$	$\psi_{cp,N}$	$N_b$ (lb)	$N_{cb}$ (lb)	$\phi$
240.25	144.00	1.000	1.000	1.000	1.000	6800	11345	0.70

Input data and results must be checked for agreement with the existing circumstances, the standards and guidelines must be checked for plausibility.



Company:		Date:	5/14/2018
Engineer:		Page:	6/6
Project:			
Address:			
Phone:			
E-mail:			

$\phi V_{cpq}$  (lb)  
15722

## 11. Results

### Interaction of Tensile and Shear Forces (Sec. R17.6)

Tension	Factored Load, $N_{ua}$ (lb)	Design Strength, $\phi N_n$ (lb)	Ratio	Status	
Steel	1000	3394	0.29	Pass	
Concrete breakout	4000	7374	0.54	Pass	
<b>Adhesive</b>	<b>4000</b>	<b>6176</b>	<b>0.65</b>	<b>Pass (Governs)</b>	
Shear	Factored Load, $V_{ua}$ (lb)	Design Strength, $\phi V_n$ (lb)	Ratio	Status	
Steel	724	1765	0.41	Pass	
T Concrete breakout x+	525	7103	0.07	Pass	
T Concrete breakout y-	2850	5313	0.54	Pass	
Concrete breakout y-	263	9797	0.03	Pass	
Concrete breakout x-	1425	12680	0.11	Pass	
<b>Concrete breakout, combined</b>	-	-	<b>0.54</b>	<b>Pass (Governs)</b>	
Pryout	2898	15722	0.18	Pass	
Interaction check	$(N_{ua}/\phi N_{ua})^{5/3}$	$(V_{ua}/\phi V_{ua})^{5/3}$	Combined Ratio	Permissible	Status
Sec. R17.6	0.48	0.36	84.5%	1.0	Pass

**SET-3G w/ 3/8"Ø F1554 Gr. 36 with hef = 4.000 inch meets the selected design criteria.**

## 12. Warnings

- Designer must exercise own judgement to determine if this design is suitable.
- Refer to manufacturer's product literature for hole cleaning and installation instructions.



JOB NO.: U2716-094-191

DESIGNED: STB

---

# Framing Analysis

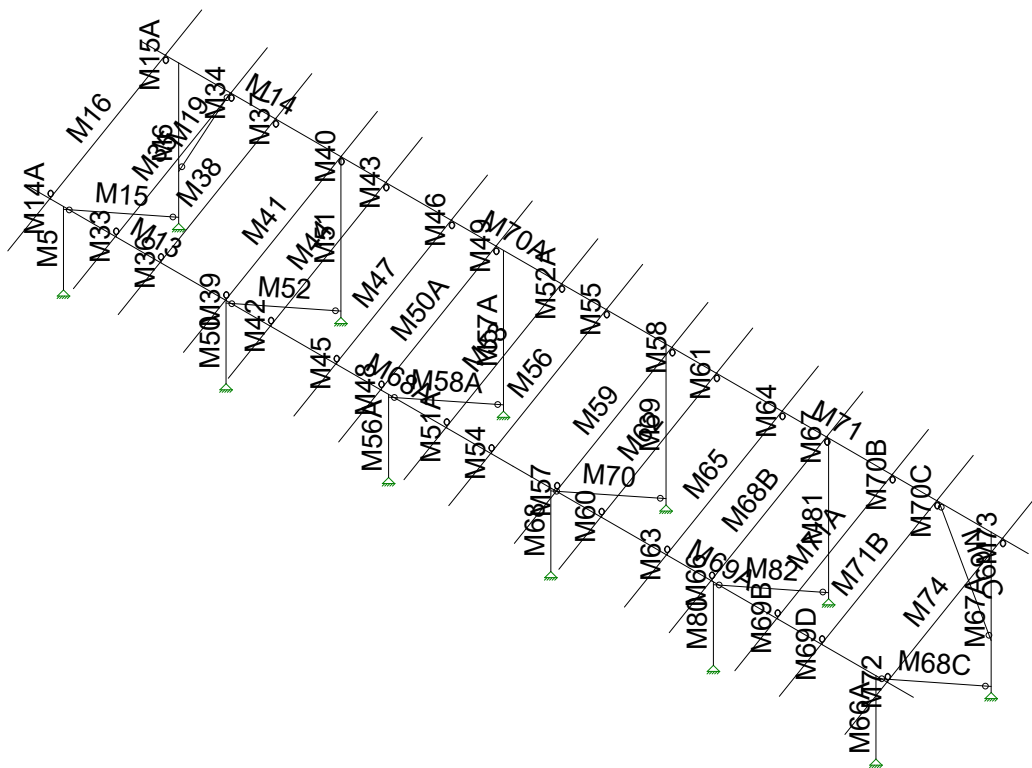

Vector Structural Engineeri...	Ground Mount	SK - 3
STB		June 7, 2019 at 3:55 PM
U2716.094.191		USA B1 GM v3.r3d

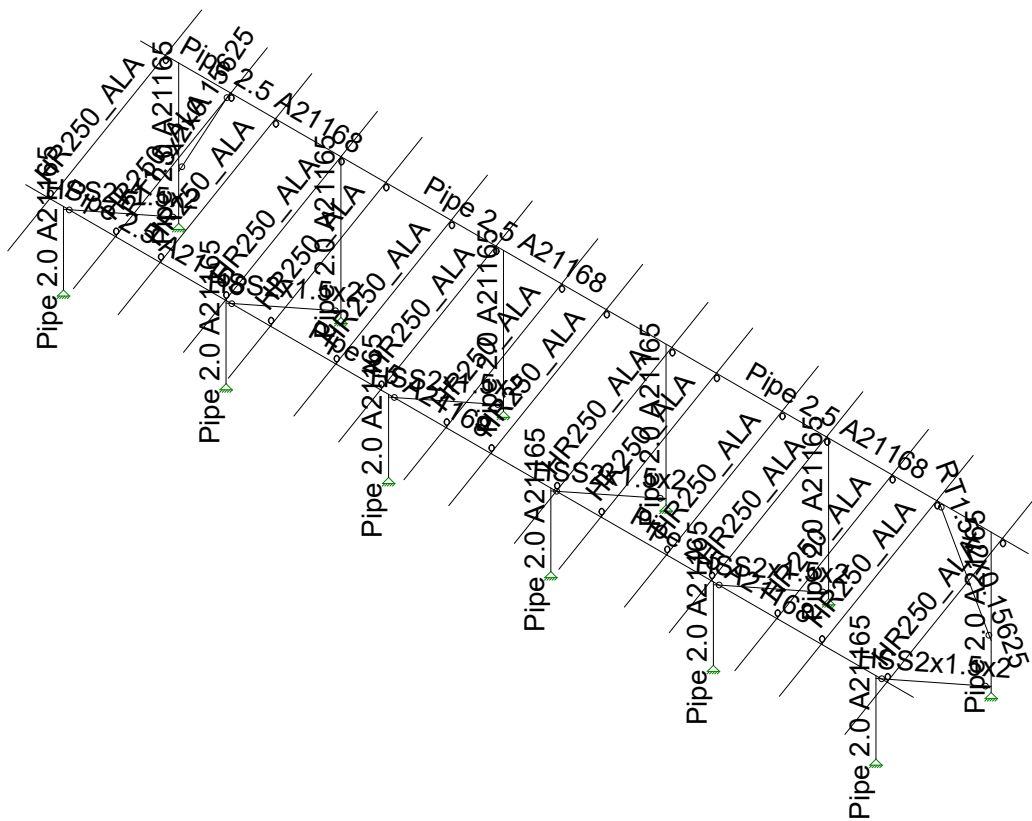

Vector Structural Engineeri...  
STB  
U2716.094.191

Ground Mount

SK - 4  
June 7, 2019 at 3:55 PM  
USA B1 GM v3.r3d

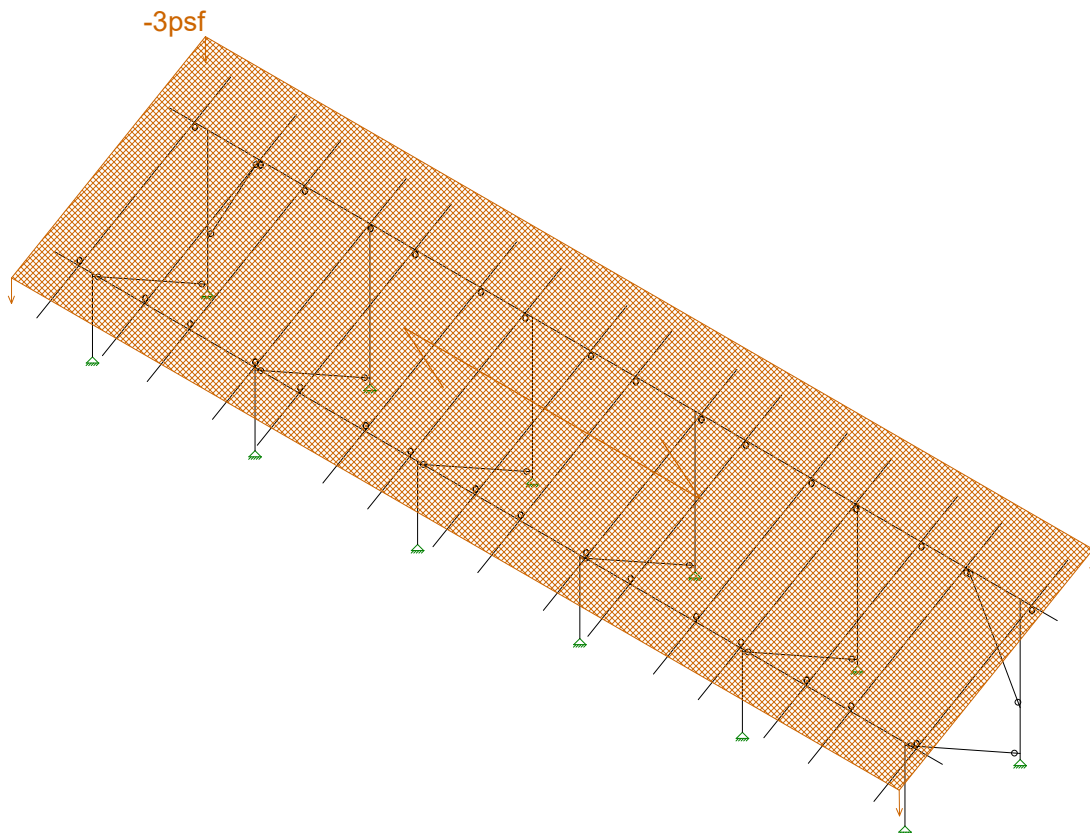

Loads: BLC 2, Solar Panel Weight

Vector Structural Engineeri..	Ground Mount	SK - 5
STB		June 7, 2019 at 3:55 PM
U2716.094.191		USA B1 GM v3.r3d

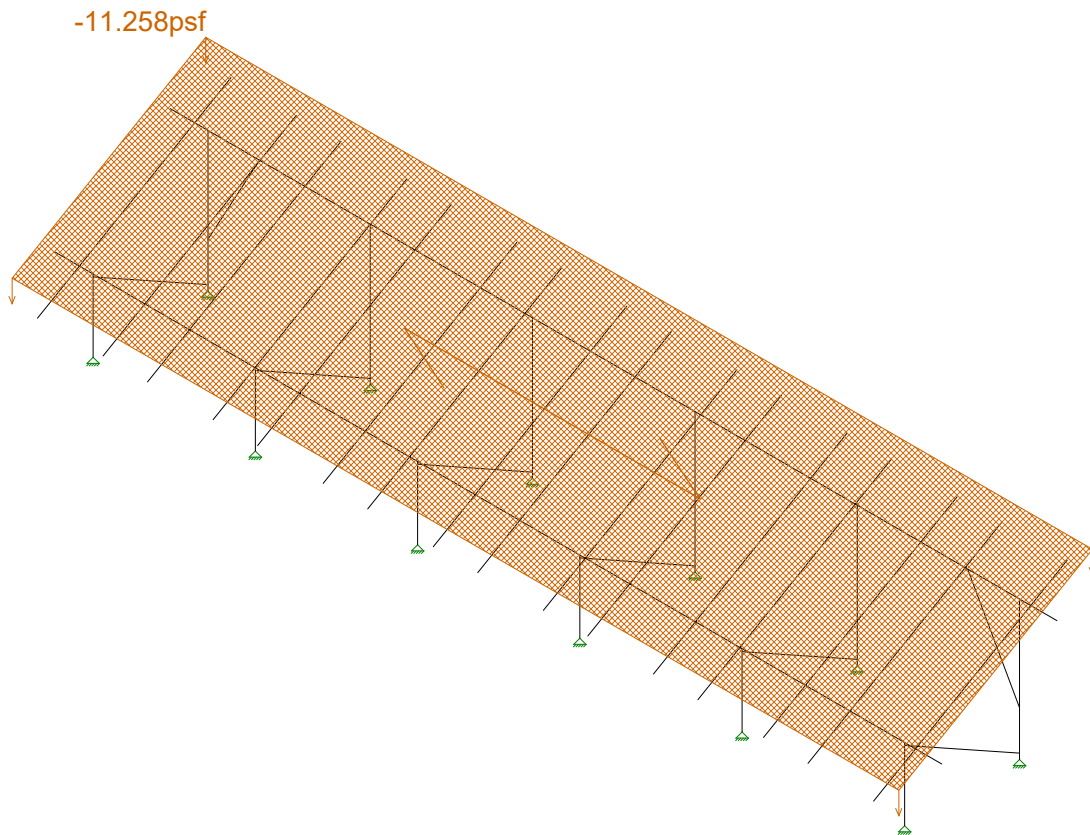

Loads: BLC 3, Roof Live/Snow

Vector Structural Engineeri..	Ground Mount	SK - 1
STB		July 25, 2019 at 4:26 PM
U2716.094.191		USA B1 GM v4.r3d



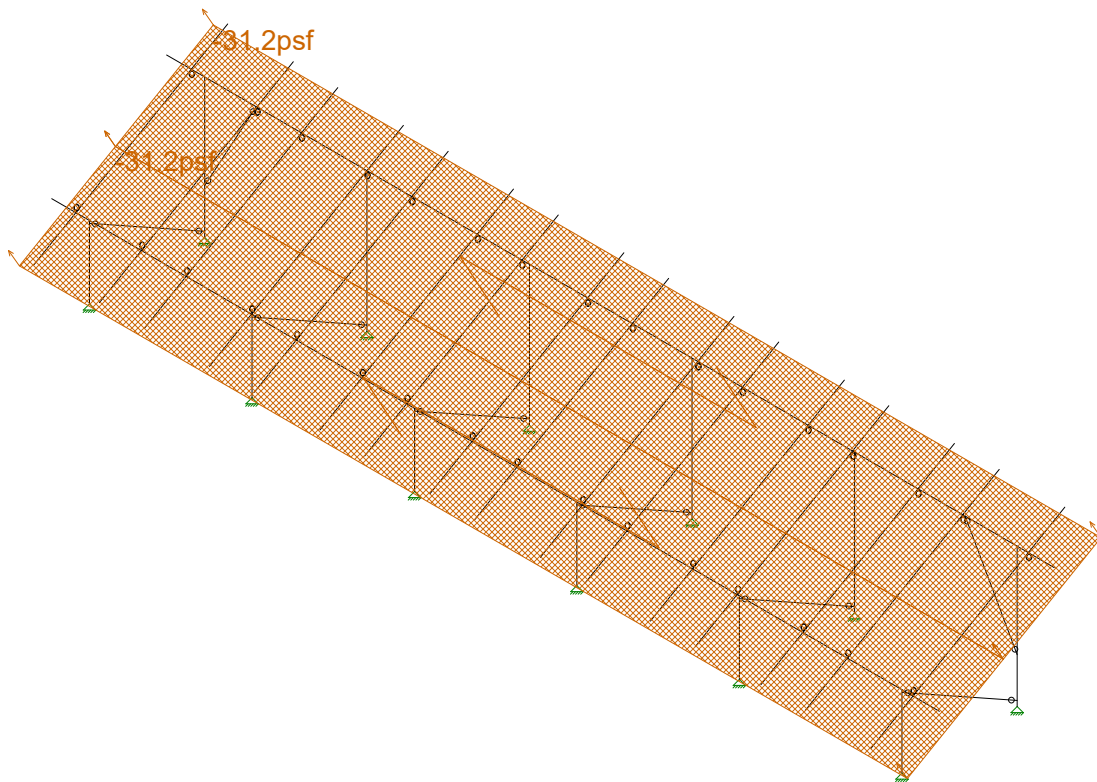

Loads: BLC 4, Wind A 0 deg

Vector Structural Engineeri..

STB

U2716.094.191

Ground Mount

SK - 7

June 7, 2019 at 3:56 PM

USA B1 GM v3.r3d

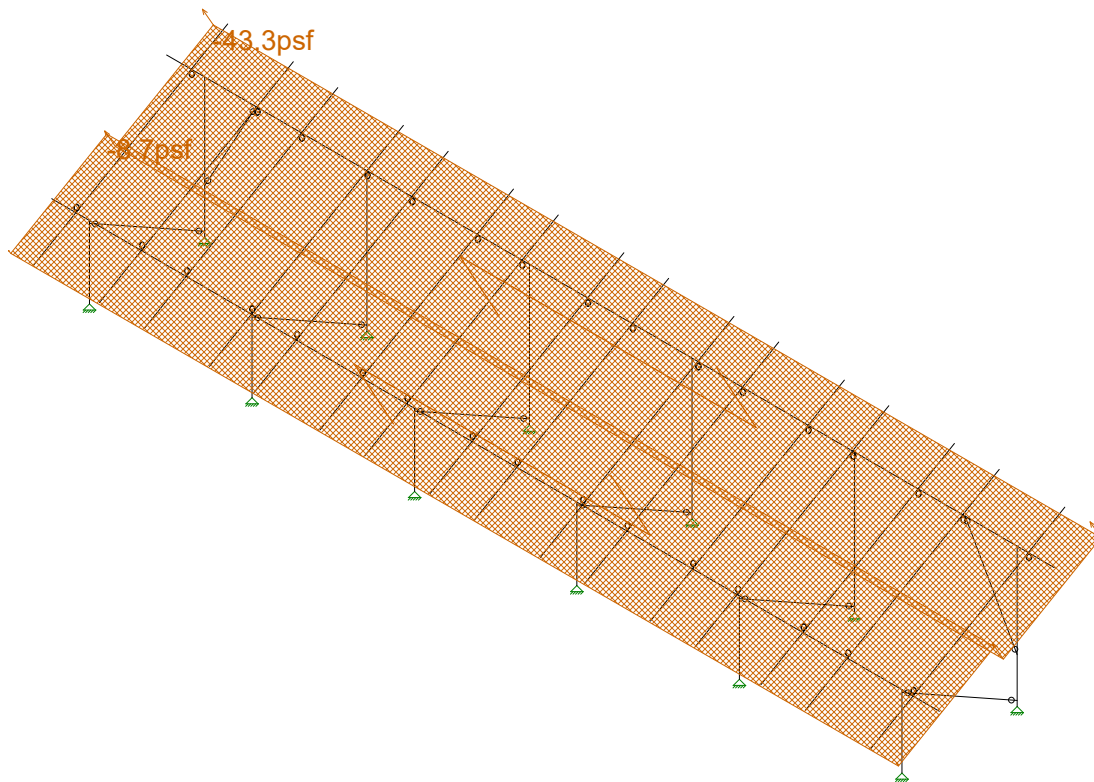

Loads: BLC 5, Wind B 0 deg

Vector Structural Engineeri..	Ground Mount	SK - 8
STB		June 7, 2019 at 3:56 PM
U2716.094.191		USA B1 GM v3.r3d

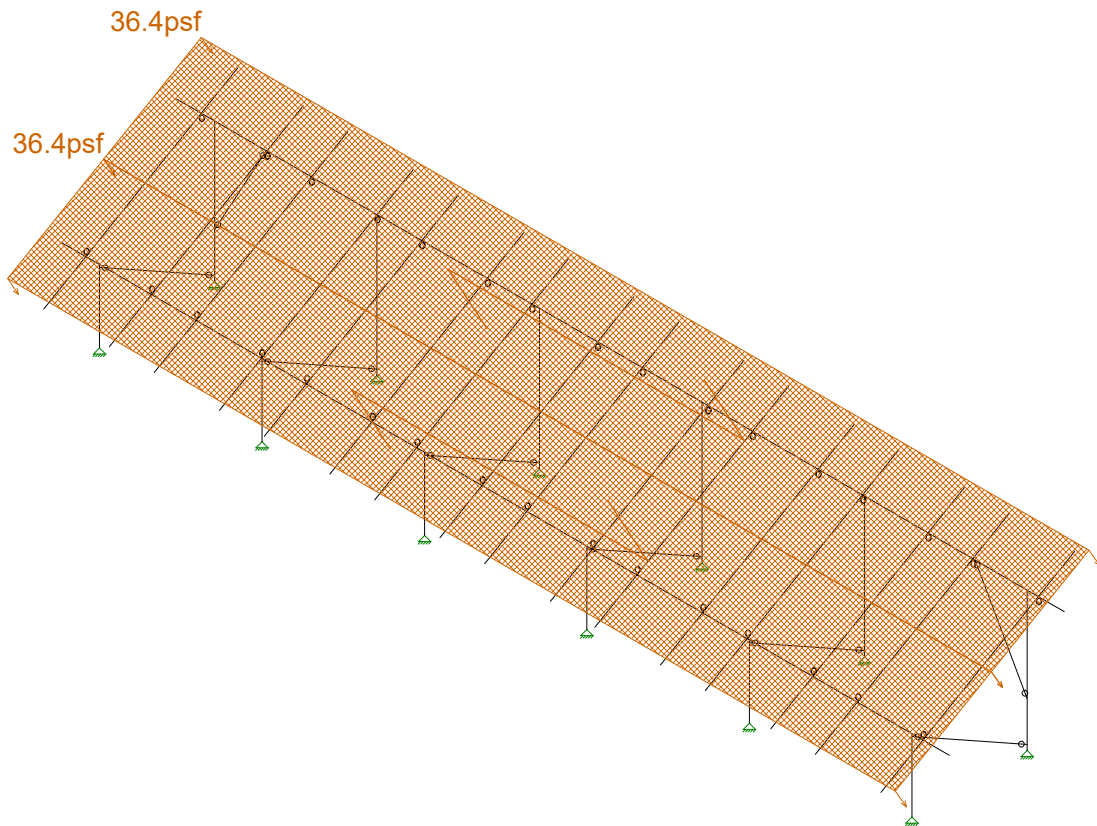

Loads: BLC 6, Wind A 180 deg

Vector Structural Engineeri..	Ground Mount	SK - 9
STB		June 7, 2019 at 3:56 PM
U2716.094.191		USA B1 GM v3.r3d

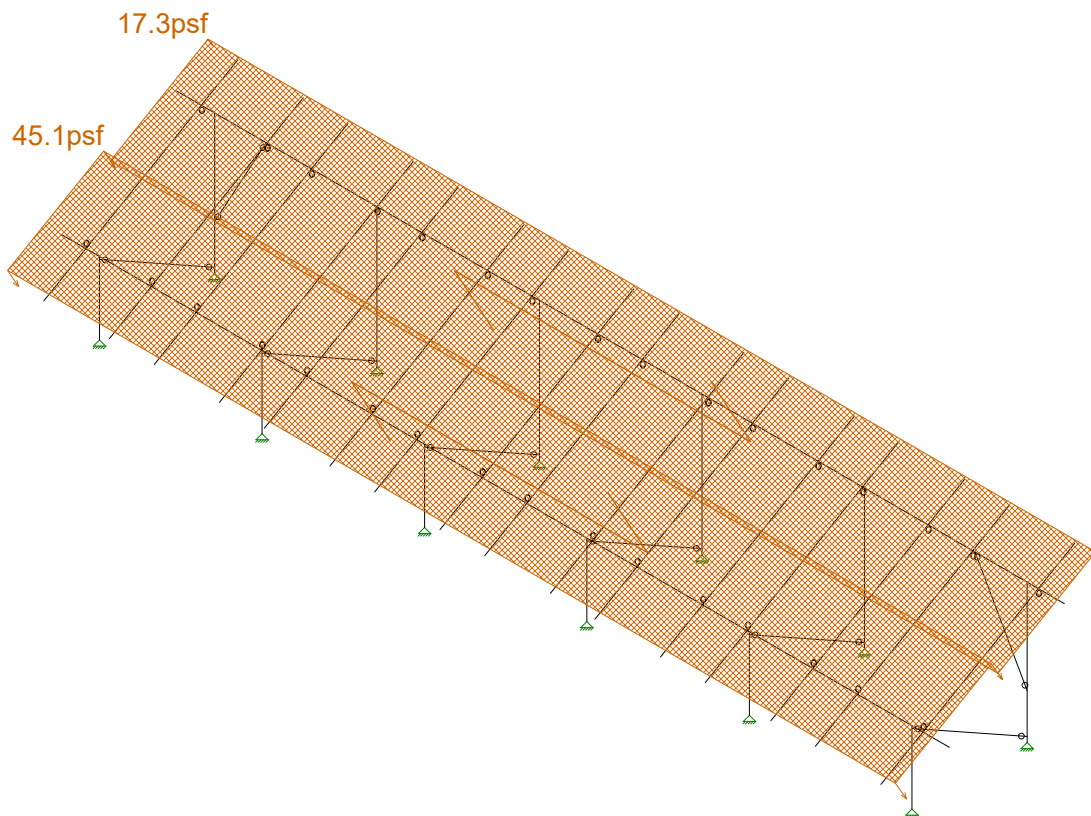

Loads: BLC 7, Wind B 180 deg

Vector Structural Engineeri..

STB

U2716.094.191

Ground Mount

SK - 10

June 7, 2019 at 3:56 PM

USA B1 GM v3.r3d

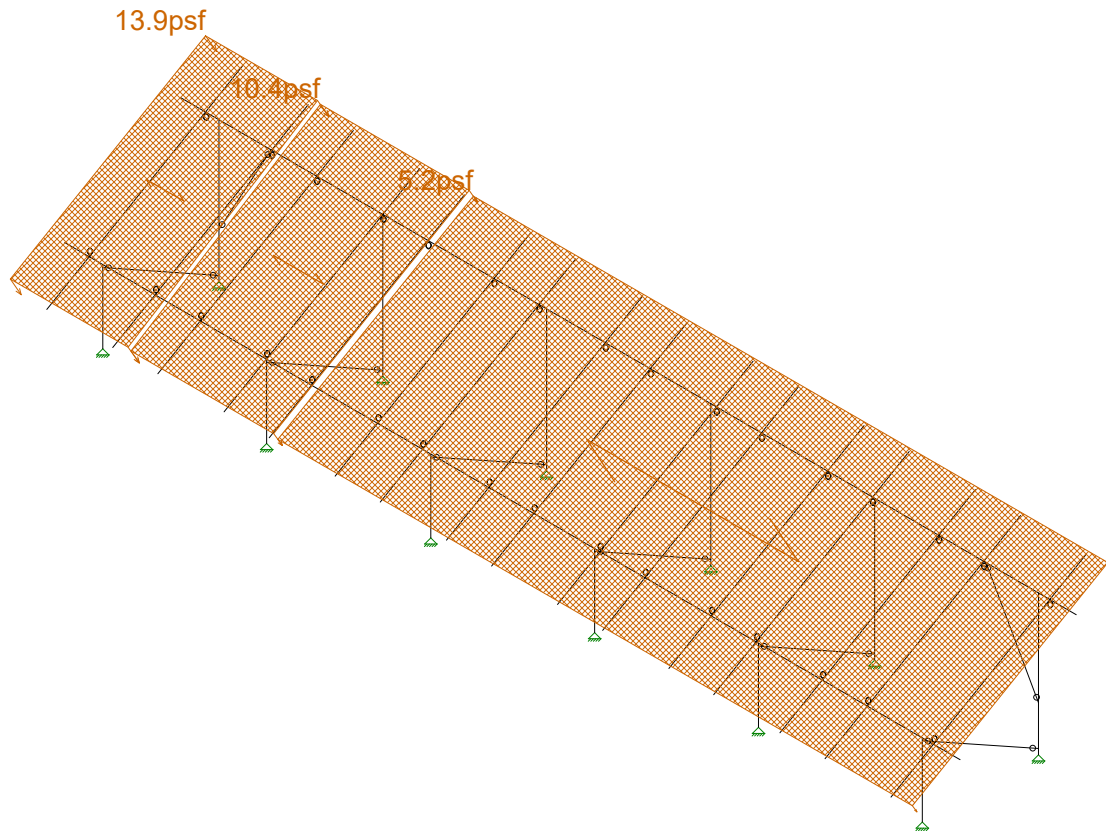

Loads: BLC 8, Wind A 90

Vector Structural Engineeri..	Ground Mount	SK - 13
STB		June 7, 2019 at 3:56 PM
U2716.094.191		USA B1 GM v3.r3d

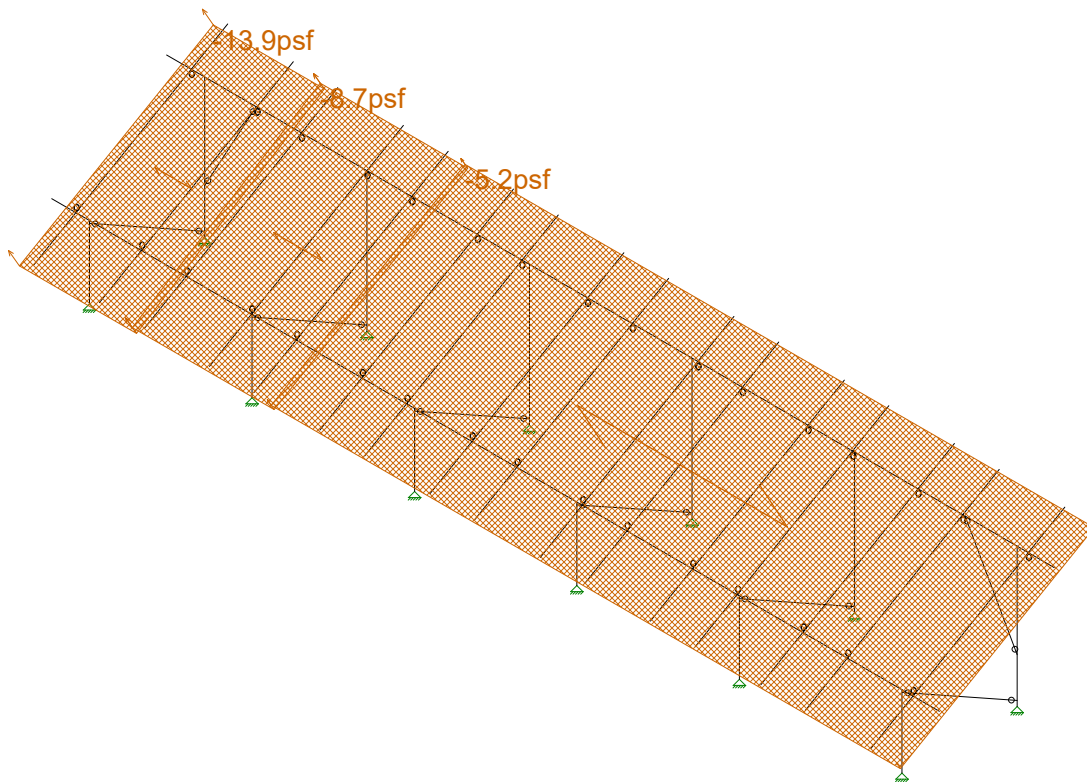

Loads: BLC 9, Wind B 90

Vector Structural Engineeri...	Ground Mount	SK - 12
STB		June 7, 2019 at 3:56 PM
U2716.094.191		USA B1 GM v3.r3d









Company : Vector Structural Engineering  
 Designer : STB  
 Job Number : U2716.094.191  
 Model Name : Ground Mount

July 25, 2019  
 4:27 PM  
 Checked By: \_\_\_\_\_

**(Global) Model Settings**

Display Sections for Member Calcs	5
Max Internal Sections for Member Calcs	97
Include Shear Deformation?	Yes
Increase Nailing Capacity for Wind?	Yes
Include Warping?	Yes
Trans Load Btwn Intersecting Wood Wall?	Yes
Area Load Mesh (in^2)	144
Merge Tolerance (in)	.12
P-Delta Analysis Tolerance	0.50%
Include P-Delta for Walls?	Yes
Automatically Iterate Stiffness for Walls?	Yes
Max Iterations for Wall Stiffness	3
Gravity Acceleration (in/sec^2)	386.4
Wall Mesh Size (in)	24
Eigensolution Convergence Tol. (1.E-)	4
Vertical Axis	Y
Global Member Orientation Plane	XZ
Static Solver	Sparse Accelerated
Dynamic Solver	Accelerated Solver

Hot Rolled Steel Code	AISC 14th(360-10): ASD
Adjust Stiffness?	Yes(Iterative)
RISAConnection Code	AISC 14th(360-10): ASD
Cold Formed Steel Code	AISI S100-16: ASD
Wood Code	AWC NDS-15: ASD
Wood Temperature	< 100F
Concrete Code	ACI 318-14
Masonry Code	ACI 530-13: ASD
Aluminum Code	AA ADM1-15: ASD - Building AISC 14th(360-10): ASD

Number of Shear Regions	4
Region Spacing Increment (in)	4
Biaxial Column Method	Exact Integration
Parme Beta Factor (PCA)	.65
Concrete Stress Block	Rectangular
Use Cracked Sections?	Yes
Use Cracked Sections Slab?	No
Bad Framing Warnings?	No
Unused Force Warnings?	Yes
Min 1 Bar Diam. Spacing?	No
Concrete Rebar Set	REBAR SET ASTMA615
Min % Steel for Column	1
Max % Steel for Column	8

**(Global) Model Settings, Continued**

Seismic Code	ASCE 7-10
Seismic Base Elevation (in)	15600
Add Base Weight?	Yes
Ct X	.02
Ct Z	.02
T X (sec)	Not Entered
T Z (sec)	Not Entered
R X	3
R Z	3
Ct Exp. X	.75
Ct Exp. Z	.75
SD1	1
SDS	1
S1	1
TL (sec)	5
Risk Cat	I or II
Drift Cat	Other
Om Z	1
Om X	1
Cd Z	4
Cd X	4
Rho Z	1
Rho X	1

**Hot Rolled Steel Properties**

	Label	E [ksi]	G [ksi]	Nu	Therm (1E5 F)	Density[lb/ft^3]	Yield[psi]	Ry	Fu[psi]	Rt
1	A992	29000	11154	.3	.65	490	50000	1.1	65000	1.1
2	A36 Gr.36	29000	11154	.3	.65	490	36000	1.5	58000	1.2
3	A572 Gr.50	29000	11154	.3	.65	490	50000	1.1	65000	1.1
4	A500 Gr.B R...	29000	11154	.3	.65	527	42000	1.4	58000	1.3
5	A500 Gr.B Re...	29000	11154	.3	.65	527	46000	1.4	58000	1.3
6	A53 Gr.B	29000	11154	.3	.65	490	35000	1.6	60000	1.2
7	A1085	29000	11154	.3	.65	490	50000	1.4	65000	1.3

**Aluminum Properties**

	Label	E [ksi]	G [ksi]	Nu	Therm (...Density[... Table B.4	kt	Ftu[psi]	Fty[psi]	Fcy[psi]	Fsu[psi]	Ct
1	3003-H14	10100	3787.5	.33	1.3 172.8 Table B.4-1	1	19000	16000	13000	12000	141
2	6061-T6	10100	3787.5	.33	1.3 172.8 Table B.4-2	1	38000	35000	35000	24000	141
3	6063-T5	10100	3787.5	.33	1.3 172.8 Table B.4-2	1	22000	16000	16000	13000	141
4	6063-T6	10100	3787.5	.33	1.3 172.8 Table B.4-2	1	30000	25000	25000	19000	141
5	5052-H34	10200	3787.5	.33	1.3 172.8 Table B.4-1	1	34000	26000	24000	20000	141
6	6061-T6 W	10100	3787.5	.33	1.3 172.8 Table B.4-1	1	24000	15000	15000	15000	141
7	6005-T5	10100	3787.5	.33	1.3 172.8 Table B.4-1	1	38000	35000	35000	24000	141

**Hot Rolled Steel Section Sets**

	Label	Shape	Type	Design List	Material	Design R...	A [in2]	Iyy [in4]	Izz [in4]	J [in4]
1	Post	Pipe 2.0 A21165	Column	Pipe	A572 Gr.50	Typical	.776	.499	.499	.998
2	Cross Beam	Pipe 2.5 A21168	Beam	Wide Flange	A572 Gr.50	Typical	.947	.907	.907	1.814
3	Diagonal Brace	1.5x1.5x0.083	Beam	Wide Flange	A36 Gr.36	Typical	.47	.158	.158	.236



Company : Vector Structural Engineering  
 Designer : STB  
 Job Number : U2716.094.191  
 Model Name : Ground Mount

July 25, 2019  
 4:27 PM  
 Checked By: \_\_\_\_\_

**Aluminum Section Sets**

	Label	Shape	Type	Design List	Material	Design R...	A [in2]	Iyy [in4]	Izz [in4]	J [in4]
1	AL Posts	2.375ODX0.188	Column	Pipe	6005-T5	Typical	1.29	.778	.778	1.54
2	AL Brace	RT1.5x2x0.15625	VBrace	Rectangular Tubes	6005-T5	Typical	.996	.327	.524	.602
3	AL Rails	HR250 ALA	Beam	Rectangular Tubes	6005-T5	Typical	.723	.095	.486	.261
4	AL Cross Beam	Cross Rail	Beam	Rectangular Tubes	6005-T5	Typical	1.909	1.97	4.366	4.017

**Member Area Loads (BLC 2 : Solar Panel Weight)**

	Joint A	Joint B	Joint C	Joint D	Direction	Distribution	Magnitude[psf]
1	N197	N200	N199	N196	Y	A-B	-3

**Member Area Loads (BLC 3 : Roof Live/Snow)**

	Joint A	Joint B	Joint C	Joint D	Direction	Distribution	Magnitude[psf]
1	N197	N200	N199	N196	PY	A-B	-13

**Member Area Loads (BLC 4 : Wind A 0 deg)**

	Joint A	Joint B	Joint C	Joint D	Direction	Distribution	Magnitude[psf]
1	N197	N200	N201	N198	Perp	A-B	-31.2
2	N198	N201	N199	N196	Perp	A-B	-31.2

**Member Area Loads (BLC 5 : Wind B 0 deg)**

	Joint A	Joint B	Joint C	Joint D	Direction	Distribution	Magnitude[psf]
1	N197	N200	N201	N198	Perp	A-B	-43.3
2	N198	N201	N199	N196	Perp	A-B	-8.7

**Member Area Loads (BLC 6 : Wind A 180 deg)**

	Joint A	Joint B	Joint C	Joint D	Direction	Distribution	Magnitude[psf]
1	N197	N200	N201	N198	Perp	A-B	36.4
2	N198	N201	N199	N196	Perp	A-B	36.4

**Member Area Loads (BLC 7 : Wind B 180 deg)**

	Joint A	Joint B	Joint C	Joint D	Direction	Distribution	Magnitude[psf]
1	N197	N200	N201	N198	Perp	A-B	17.3
2	N198	N201	N199	N196	Perp	A-B	45.1

**Member Area Loads (BLC 8 : Wind A 90)**

	Joint A	Joint B	Joint C	Joint D	Direction	Distribution	Magnitude[psf]
1	N197	N203	N202	N196	Perp	A-B	13.9
2	N203	N209	N208	N202	Perp	A-B	10.4
3	N209	N200	N199	N208	Perp	A-B	5.2

**Member Area Loads (BLC 9 : Wind B 90)**

	Joint A	Joint B	Joint C	Joint D	Direction	Distribution	Magnitude[psf]
1	N197	N203	N202	N196	Perp	A-B	-13.9
2	N203	N209	N208	N202	Perp	A-B	-8.7
3	N209	N200	N199	N208	Perp	A-B	-5.2

**Basic Load Cases**

	BLC Description	Category	X Gravity	Y Gravity	Z Gravity	Joint	Point	Distributed	Area(M...Surface...
1	Self Weight	DL		-1.05					
2	Solar Panel Weight	DL							1





Company : Vector Structural Engineering  
 Designer : STB  
 Job Number : U2716.094.191  
 Model Name : Ground Mount

July 25, 2019  
 4:27 PM  
 Checked By: \_\_\_\_\_

**Envelope Joint Reactions (Continued)**

Joint	X [lb]	LC	Y [lb]	LC	Z [lb]	LC	MX [lb-ft]	LC	MY [lb-ft]	LC	MZ [lb-ft]	LC
14	min -4.724	11	-2379.431	16	-1310....	3	0	1	0	1	0	1
15	N122 max 2.438	17	1402.928	10	46.734	3	0	1	0	1	0	1
16	min -3.166	10	146.323	15	-55.764	5	0	1	0	1	0	1
17	N133B max 4.409	11	2862.326	5	1530.8...	5	0	1	0	1	0	1
18	min -4.321	16	-2380.654	16	-1311....	3	0	1	0	1	0	1
19	N134B max 3.347	10	1403.922	10	46.761	3	0	1	0	1	0	1
20	min -1.807	19	147.379	15	-55.785	5	0	1	0	1	0	1
21	N137C max 167.486	16	2068.283	5	1017.4...	5	0	1	0	1	0	1
22	min -211.898	11	-1706.119	16	-871.046	3	0	1	0	1	0	1
23	N138B max 70.387	15	947.043	12	35.284	3	0	1	0	1	0	1
24	min -137.176	12	61.204	15	-42.154	5	0	1	0	1	0	1
25	Totals: max .028	8	20164.654	11	8215.0...	17						
26	min -.034	7	-10310.111	15	-7041....	3						

**Envelope AISC 14th(360-10): ASD Steel Code Checks**

Member	Shape	Code Check	Loc[in]	LC	Shear ...	Loc[in]	Dir	LC	Pnc/om [...]	Pnt/om [lb]	Mnyy/om...	Mnzz/om...Cb	Eqn
1	M5	Pipe 2.0 A2...	.492	53.334	12 .164	51.667		5	16814.608	23232.186	1397.505	1397.505	1... H1-1b
2	M6	Pipe 2.0 A2...	.641	32.11	11 .158	0		5	7106.531	23232.186	1397.505	1397.505	1... H1-1a
3	M13	Pipe 2.5 A2...	.852	148....	12 .182	148....		5	9469.68	28358.413	2081.747	2081.747	1... H1-1b
4	M14	Pipe 2.5 A2...	.617	148....	11 .186	148....		5	11641.036	28358.413	2081.747	2081.747	2... H1-1b
5	M15	1.5x1.5x0.083	.513	49.709	5 .124	97.388	y	11	2503.517	10141.308	449.583	449.583	1... H1-1a
6	M80	Pipe 2.0 A2...	.200	51.667	5 .251	51.667		5	16814.608	23232.186	1397.505	1397.505	1... H1-1b
7	M81	Pipe 2.0 A2...	.720	3.211	5 .261	0		5	7106.531	23232.186	1397.505	1397.505	1... H1-1a
8	M82	1.5x1.5x0.083	.843	49.709	5 .010	97.388	y	13	2503.517	10141.308	449.583	449.583	1... H1-1a
9	M50	Pipe 2.0 A2...	.199	51.667	5 .251	51.667		5	16814.608	23232.186	1397.505	1397.505	1... H1-1b
10	M51	Pipe 2.0 A2...	.719	3.211	5 .260	0		5	7106.531	23232.186	1397.505	1397.505	1... H1-1a
11	M52	1.5x1.5x0.083	.842	49.709	5 .011	0	y	14	2503.517	10141.308	449.583	449.583	1... H1-1a
12	M56A	Pipe 2.0 A2...	.191	51.667	5 .223	51.667		5	16814.608	23232.186	1397.505	1397.505	1... H1-1b
13	M57A	Pipe 2.0 A2...	.679	3.211	5 .233	0		5	7106.531	23232.186	1397.505	1397.505	1... H1-1a
14	M58A	1.5x1.5x0.083	.755	49.709	5 .008	97.388	y	13	2503.517	10141.308	449.583	449.583	1... H1-1a
15	M68	Pipe 2.0 A2...	.191	51.667	5 .223	51.667		5	16814.608	23232.186	1397.505	1397.505	1... H1-1b
16	M69	Pipe 2.0 A2...	.679	3.211	5 .233	0		5	7106.531	23232.186	1397.505	1397.505	1... H1-1a
17	M70	1.5x1.5x0.083	.756	49.709	5 .008	97.388	y	14	2503.517	10141.308	449.583	449.583	1... H1-1a
18	M68A	Pipe 2.5 A2...	.826	88.125	12 .164	86.25		12	11641.036	28358.413	2081.747	2081.747	1... H1-1b
19	M69A	Pipe 2.5 A2...	.856	147.8	12 .180	147.8		5	11641.036	28358.413	2081.747	2081.747	1... H1-1b
20	M70A	Pipe 2.5 A2...	.725	88.125	11 .178	86.25		11	11641.036	28358.413	2081.747	2081.747	1... H1-1b
21	M71	Pipe 2.5 A2...	.711	27.713	11 .185	147.8		5	11641.036	28358.413	2081.747	2081.747	1... H1-1b
22	M66A	Pipe 2.0 A2...	.496	53.334	12 .163	51.667		5	16814.608	23232.186	1397.505	1397.505	1... H1-1b
23	M67A	Pipe 2.0 A2...	.639	32.11	11 .157	0		5	7106.531	23232.186	1397.505	1397.505	1... H1-1a
24	M68C	1.5x1.5x0.083	.510	49.709	5 .124	0	y	11	2503.517	10141.308	449.583	449.583	1... H1-1a

**Envelope AA ADM1-15: ASD - Building Aluminum Code Checks**

Member	Shape	Code C...	Loc[in]	LC	Shear ...	Loc[in]	Dir	LC	Pnc/O...	Pnt/Om...	Mny/O...	Mnz/O...	Vny/O...	Vnz/O...	Cb	Eqn
1	M19	RT1.5x2x...	.289	47.124	11 .011	0	z	11	2665.885	19411....	770.742	927.083	6090.199	4101.563	1... H.1-1	
2	M16	HR250_A...	.833	36.144	12 .088	37.865	y	12	2221.164	14089....	309.506	613.954	5108.727	1672.364	1 H.1-1	
3	M35	HR250_A...	.844	87.778	11 .097	37.865	y	12	2221.164	14089....	309.506	613.954	5108.727	1672.364	1 H.1-1	
4	M38	HR250_A...	.763	36.144	12 .090	37.865	y	12	2221.164	14089....	309.506	613.954	5108.727	1672.364	1 H.1-1	
5	M41	HR250_A...	.971	89.499	16 .082	37.865	y	12	2221.164	14089....	309.506	613.954	5108.727	1672.364	1 H.1-1	
6	M44	HR250_A...	.763	36.144	12 .082	37.865	y	12	2221.164	14089....	309.506	613.954	5108.727	1672.364	1 H.1-1	
7	M47	HR250_A...	.763	36.144	12 .080	37.865	y	12	2221.164	14089....	309.506	613.954	5108.727	1672.364	1 H.1-1	
8	M50A	HR250_A...	.958	89.499	16 .077	37.865	y	12	2221.164	14089....	309.506	613.954	5108.727	1672.364	1 H.1-1	
9	M53	HR250_A...	.763	36.144	12 .083	37.865	y	12	2221.164	14089....	309.506	613.954	5108.727	1672.364	1 H.1-1	
10	M56	HR250_A...	.763	36.144	12 .083	37.865	y	12	2221.164	14089....	309.506	613.954	5108.727	1672.364	1 H.1-1	
11	M59	HR250_A...	.959	89.499	16 .077	37.865	y	12	2221.164	14089....	309.506	613.954	5108.727	1672.364	1 H.1-1	



Company : Vector Structural Engineering  
 Designer : STB  
 Job Number : U2716.094.191  
 Model Name : Ground Mount

July 25, 2019  
 4:27 PM  
 Checked By: \_\_\_\_\_

**Envelope AA ADM1-15: ASD - Building Aluminum Code Checks (Continued)**

Member	Shape	Code C...	Loc[in]	LC Shear ...	Loc[in]	Dir	LC Pnc/O...	Pnt/Om...	Mny/O...	Mnz/O...	Vny/O...	Vnz/O...	Cb	Eqn
12	M62	HR250_A...	.763	36.144	12	.081	37.865	y	12	2221.164	14089....	309.506	613.954	5108.7271672.364 1 H.1-1
13	M65	HR250_A...	.763	36.144	12	.082	37.865	y	12	2221.164	14089....	309.506	613.954	5108.7271672.364 1 H.1-1
14	M68B	HR250_A...	.974	89.499	16	.082	37.865	y	12	2221.164	14089....	309.506	613.954	5108.7271672.364 1 H.1-1
15	M71A	HR250_A...	.763	36.144	12	.090	37.865	y	12	2221.164	14089....	309.506	613.954	5108.7271672.364 1 H.1-1
16	M69C	RT1.5x2x...	.287	47.196	11	.011	0	z	12	2657.816	19411....	770.742	927.083	6090.1994101.5631... H.1-1
17	M71B	HR250_A...	.833	87.778	11	.097	37.865	y	12	2221.164	14089....	309.506	613.954	5108.7271672.364 1 H.1-1
18	M74	HR250_A...	.837	36.144	12	.088	37.865	y	12	2221.164	14089....	309.506	613.954	5108.7271672.364 1 H.1-1

NOTES: UNLESS OTHERWISE SPECIFIED  
 1. DIMENSIONS SHOWN ARE INCHES [MILLIMETERS].

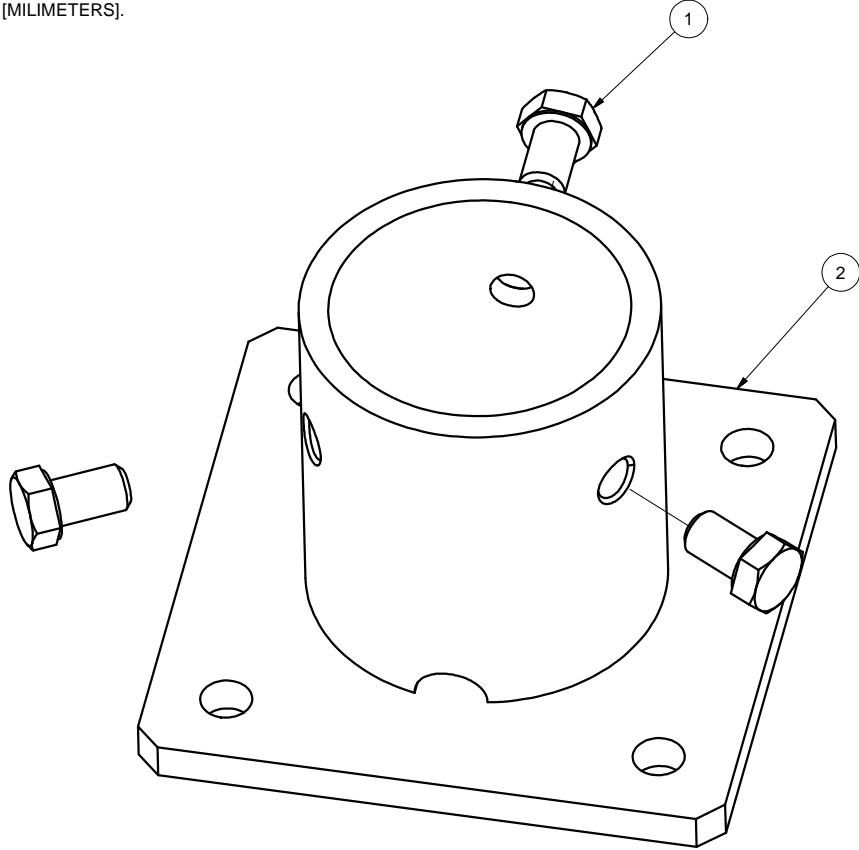

REVISIONS			
REV	DESCRIPTION	BY	DATE
A	INITIAL RELEASE	LWF	10/20/2016

2	A21120-001	2" PIPE BASE	1
1	B15018-011	HEX CAP SCREW 3/8-16 X 5/8	3
ITEM	PART NUMBER	DESCRIPTION	QTY
MATERIAL		SEE NOTES	
Third Angle Projection:			
GENERAL SPECIFICATIONS		<b>Sunmodo Corp.</b> 1905 E 5TH STREET, STE A, VANCOUVER, WA 98661	
Tolerances		TITLE	
X.XXX ±0.01 [0.25mm]		2" PIPE BASE KIT	
X.XX ±0.02 [0.50mm]		DRAWING NUMBER	
X.X ±0.039 [1.0mm]		B K10268-001	
Unless otherwise spec'd		SCALE: NONE	
DRAWN BY		SHEET 1 of 1	
LWF		DATE	
CHECKED BY		10/20/2016	
APPROVALS			

THIS DRAWING IS CONFIDENTIAL PROPERTY OF SUNMODO AND ITS CONTENTS MAY NOT BE DISCLOSED WITHOUT THE PRIOR WRITTEN CONSENT OF SUNMODO CORP.

NOTES: UNLESS OTHERWISE SPECIFIED

1. DIMENSIONS SHOWN ARE INCHES [MILIMETERS].
2. MATERAIL: ALUMINUM 6005-T5.  
FINISH: CLEAR ANODIZED 10 μm THICK.
3. THE UNSPECIFIED DIMENSIONS ARE SPECIFIED BY 2D CAD FILE.

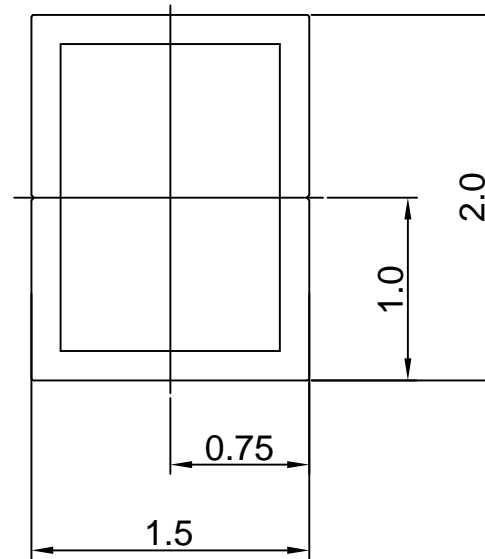

## Section properties:

Weight: 1.156 lbs/ft

Area: 0.992 in<sup>2</sup>

Perimeter: 12.601 in

Bounding Box: X: -1.000,1.000

Y: -0.750, 0.750

Centroid:(0.000,0.000)

Moments of Inertia(in<sup>4</sup>): I<sub>x</sub>=0.506,I<sub>y</sub>=0.322

Section modulus in bending(in<sup>3</sup>): W<sub>x</sub>=0.675,W<sub>y</sub>=0.322

Radii of Gyration: X: 0.714, Y: 0.570

MATERIAL		<b>SEE NOTES</b>	
Third Angle Projection:		<b>Sunmodo Corp.</b> 1905 E 5TH STREET, SUITE A, VANCOUVER, WA 98661	
GENERAL SPECIFICATIONS All Dimensions in inches [millimeters]			
Tolerances X.XXX ± 0.01 [0.25mm] X.XX ± 0.02 [0.50mm] X.X ± 0.039 [1.0mm] Unless otherwise specd		Break all sharp edges .010-.020 unless otherwise specified.	
DRAWN BY zcg	DATE 03/12/2014	TITLE 1.5X2 AL TUBE BRACE EXTRUSION	
CHECKED BY		B	DRAWING NUMBER A20164
APPROVALS		SCALE:	NONE SHEET 1 of 1



REVISIONS			
REV	DESCRIPTION	BY	DATE
A	ADDED BOTTOM CHANNEL & CHANGED ONE 3/8 CHANNEL TO 1/4	zcg	02/21/2013

NOTES: UNLESS OTHERWISE SPECIFIED

1. DIMENSIONS SHOWN ARE INCHES [MILIMETERS].
2. MATERAIL: ALUMINUM 6005-T5.  
FINISH: CLEAR ANODIZED 15  $\mu$ m THICK.
3. THE UNSPECIFIED DIMENSIONS ARE SPECIFIED BY 2D CAD FILE.

2X 1/4 BOLT SLOT

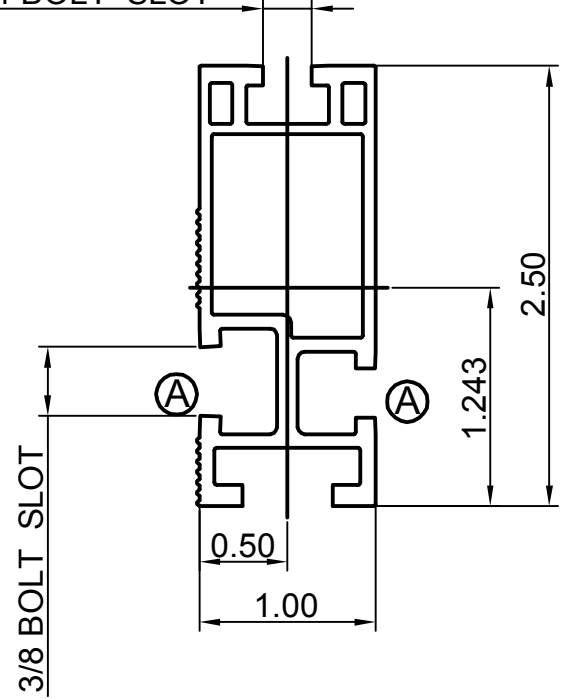

### Section properties:

Weight: 0.850 lbs/ft  
 Area: 0.723 in<sup>2</sup>  
 Perimeter: 17.325 in  
 Bounding Box: X: -0.500,0.500  
 Y: -1.243,1.257

Centroid:(0.000,0.000)  
 Moments of Incertia(in<sup>4</sup>): Ix=0.486,Iy=0.095  
 Section modulus in bending(in<sup>3</sup>): Wx=0.387,Wy=0.190  
 Radii of Gyration: X: 0.820, Y: 0.363

MATERIAL SEE NOTES		<b>Sunmodo Corp.</b>	
Third Angle Projection:			
GENERAL SPECIFICATIONS All Dimensions in inches [millimeters]		1905 E 5TH STREET, SUITE A, VANCOUVER, WA 98661	
Tolerances: X.XXX ± 0.01 [0.25mm] X.XX ± 0.02 [0.50mm] X.X ± 0.039 [1.0mm] Unless otherwise spec'd		TITLE HELIO STANDARD RAIL	
DRAWN BY zcg	DATE 02/21/2013	DRAWING NUMBER A20144	
CHECKED BY		SCALE: NONE SHEET 1 of 1	
APPROVALS			

NOTES: UNLESS OTHERWISE SPECIFIED

1. DIMENSIONS SHOWN ARE INCHES [MILIMETERS].
2. MATERIAL: 6005-T5.  
FINISH: CLEAR ANODIZED 10um THICK.
3. THE UNSPECIFIED RADII ARE .02" MAX.
4. THE UNSPECIFIED DIMENSIONS ARE SPECIFIED BY 2D CAD FILE.

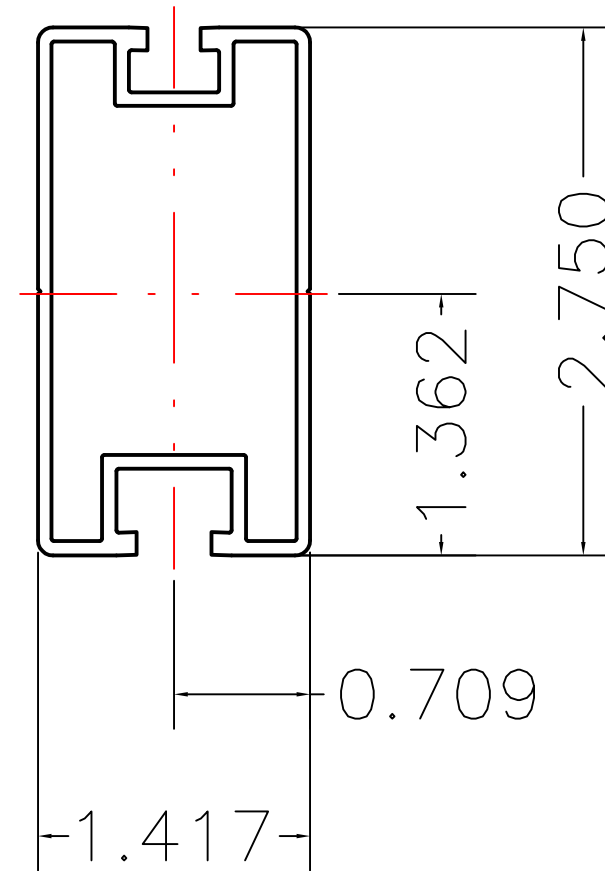

### Section properties:

Weight: 0.862 lbs/ft  
 Area: 0.736 in<sup>2</sup>  
 Perimeter: 19.824 in  
 Bounding Box: X: -0.709,0.709  
                   Y: -1.362,1.388  
 Centroid:(0.000,0.000)  
 Moments of Inertia(in<sup>4</sup>): I<sub>x</sub>=0.727,I<sub>y</sub>=0.214  
 Section modulus in bending(in<sup>3</sup>): W<sub>x</sub>=0.524,W<sub>y</sub>=0.302  
 Radii of Gyration: X: 994, Y: 0.539

THIS DRAWING IS CONFIDENTIAL PROPERTY OF SUNMODO AND ITS CONTENTS MAY NOT BE DISCLOSED WITHOUT THE PRIOR WRITTEN CONSENT OF SUNMODO CORP.

MATERIAL SEE NOTES		<b>SunModo Corp.</b> 14800 NE 65TH STREET, VANCOUVER WA 98682	
Third Angle Projection:			
GENERAL SPECIFICATIONS All Dimensions in inches [millimeters]		TITLE RAIL, HR300 (SUNRAY), EXTRUSION	
Tolerances X.XXX ±0.01 [0.25mm] X.XX ±0.02 [0.50mm] Break all sharp edges X.X ±0.039 [1.0mm] .010-.020 unless otherwise specified. Unless otherwise spec'd			
DRAWN BY KYY	DATE 01/18/2018	B	DRAWING NUMBER A20288
CHECKED BY			
APPROVALS		SCALE: NONE	SHEET 1 of 1

REV	DESCRIPTON	BY	DATE
A	0.44 WAS 0.41, 0.44 WAS 0.33	LWF	11/30/2015

NOTES: UNLESS OTHERWISE SPECIFIED

1. DIMENSIONS SHOWN ARE INCHES [MILIMETERS].
2. MATERIAL: ALUMINUM 6005-T5.  
FINISH: CLEAR ANODIZED 15  $\mu$ m THICK.
3. THE UNSPECIFIED DIMENSIONS ARE SPECIFIED BY 2D CAD FILE.

2X 1/4 BOLT SLOT

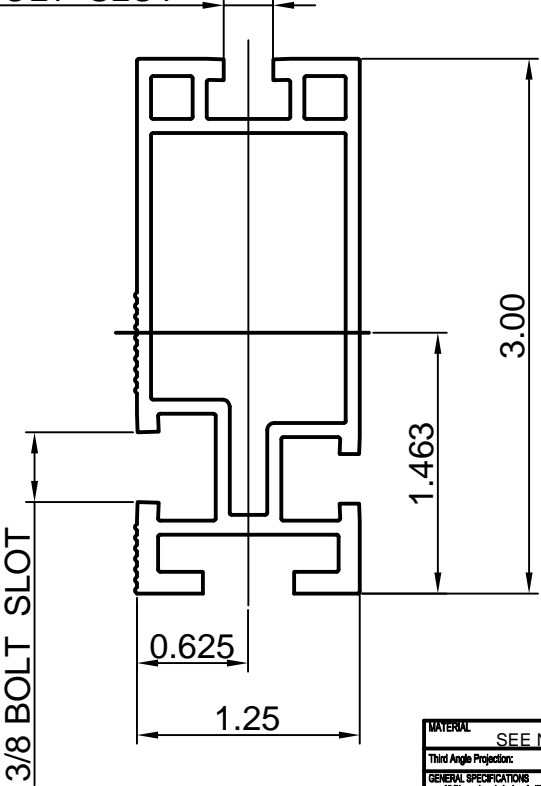

**Section properties:**

Weight: 1.151 lbs/ft  
 Area: 0.980 in<sup>2</sup>  
 Perimeter: 22.104 in  
 Bounding Box: X: -0.625,0.625  
                   Y: -1.463,1.537  
 Centroid:(0.000,0.000)  
 Moments of Inertia(in<sup>4</sup>): Ix=1.047,Iy=0.207  
 Section modulus in bending(in<sup>3</sup>): Wx=0.681,Wy=0.331  
 Radii of Gyration: X: 1.034, Y: 0.460

MATERIAL		SEE NOTES	
Third Angle Projection			
GENERAL SPECIFICATIONS			
All Dimensions in Inches (millimeters)			
Tolerances			
XXX ±0.01 (0.25mm)			
XX ±0.02 (0.50mm)			
X ±0.03 (1.0mm)			
Unless otherwise noted			
Break all sharp edges 0.10-0.25 unless otherwise specified.			
DRAWN BY		DATE	
ZCJ		02/21/2013	
CHECKED BY		B	
APPROVALS		DRAWING NUMBER	
		A20145	
SCALE:		SHEET	
NONE		1 of 1	

**Sunmodo Corp.**

1905 E 5TH STREET, SUITE A, VANCOUVER, WA 98661

TITLE  
HELIO HEAVY RAIL

B DRAWING NUMBER  
A20145

SCALE: NONE SHEET 1 of 1

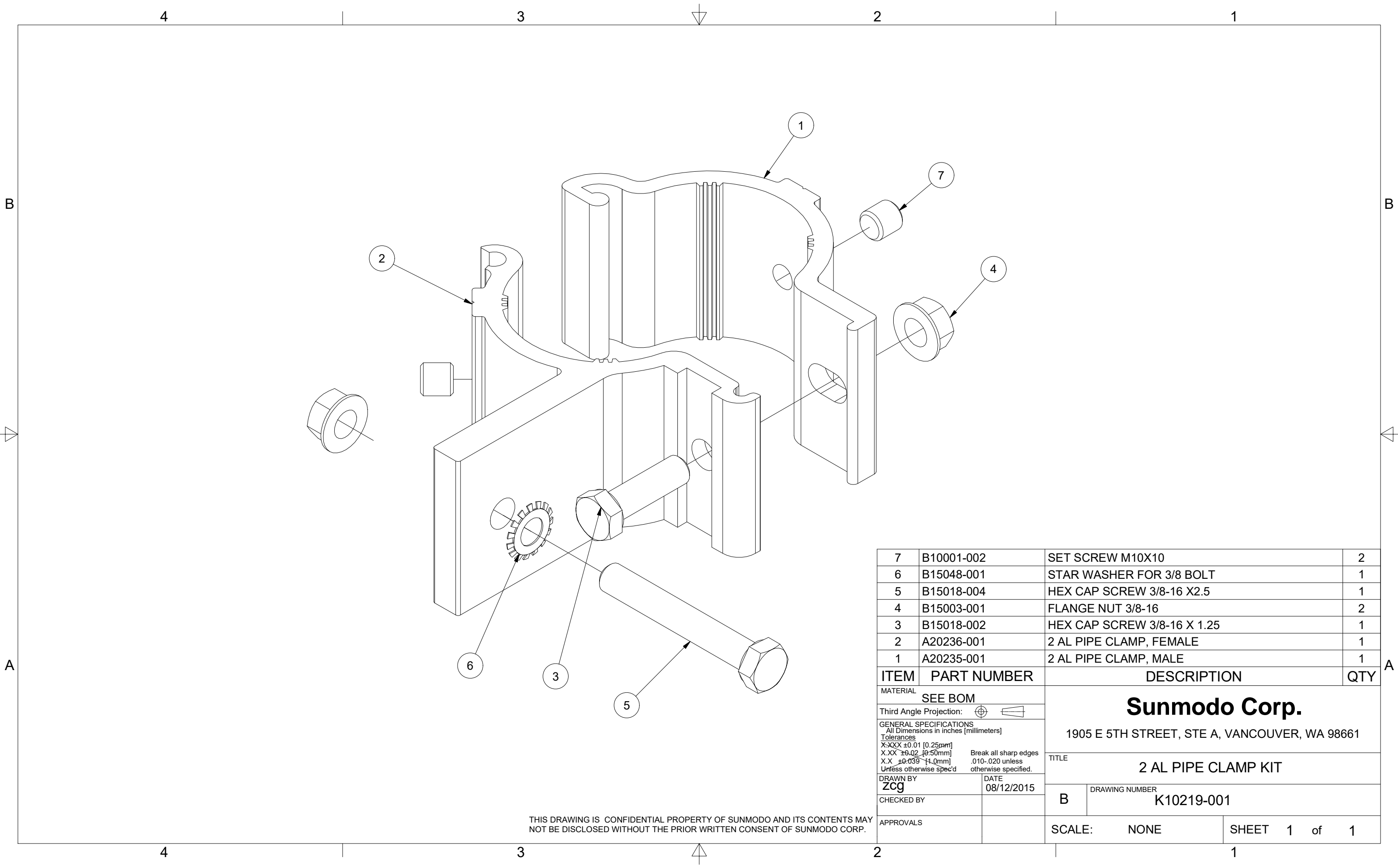

7	B10001-002	SET SCREW M10X10	2
6	B15048-001	STAR WASHER FOR 3/8 BOLT	1
5	B15018-004	HEX CAP SCREW 3/8-16 X2.5	1
4	B15003-001	FLANGE NUT 3/8-16	2
3	B15018-002	HEX CAP SCREW 3/8-16 X 1.25	1
2	A20236-001	2 AL PIPE CLAMP, FEMALE	1
1	A20235-001	2 AL PIPE CLAMP, MALE	1

ITEM	PART NUMBER	DESCRIPTION	QTY
MATERIAL		SEE BOM	
Third Angle Projection:			
GENERAL SPECIFICATIONS All Dimensions in inches (millimeters)			
Tolerances			
X.XXX ±0.01 [0.25mm]		Break all sharp edges	
X.XX ±0.02 [0.50mm]		.010-.020 unless	
X.X ±0.039 [1.0mm]		otherwise specified.	
DRAWN BY		DATE	
zcg		08/12/2015	
CHECKED BY		TITLE	
		2 AL PIPE CLAMP KIT	
APPROVALS		DRAWING NUMBER	
		B K10219-001	
SCALE:		NONE	SHEET 1 of 1

THIS DRAWING IS CONFIDENTIAL PROPERTY OF SUNMODO AND ITS CONTENTS MAY NOT BE DISCLOSED WITHOUT THE PRIOR WRITTEN CONSENT OF SUNMODO CORP.

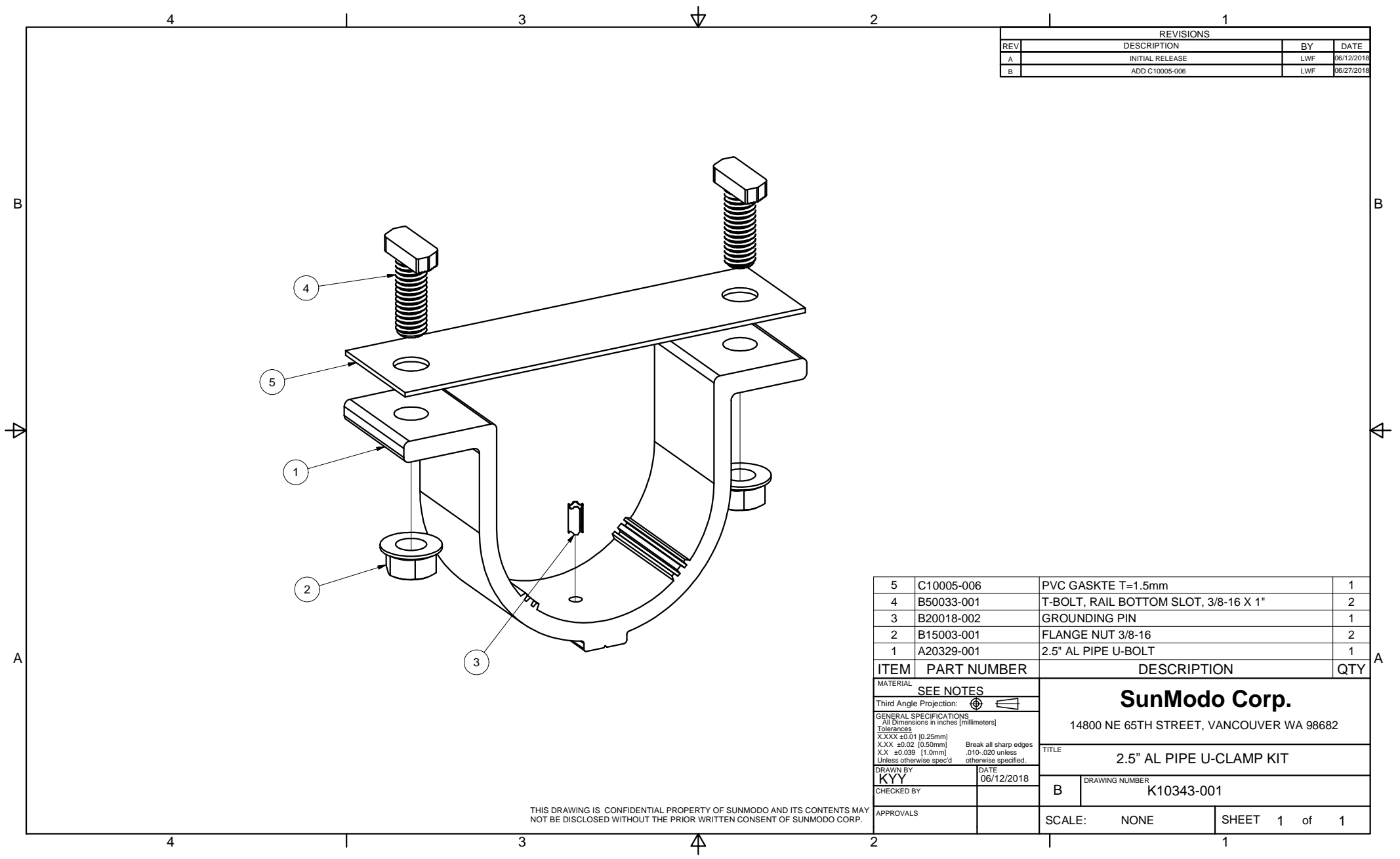

REVISIONS			
REV	DESCRIPTION	BY	DATE
A	INITIAL RELEASE	LWF	06/12/2018
B	ADD C10005-006	LWF	06/27/2018

ITEM	PART NUMBER	DESCRIPTION	QTY
5	C10005-006	PVC GASKTE T=1.5mm	1
4	B50033-001	T-BOLT, RAIL BOTTOM SLOT, 3/8-16 X 1"	2
3	B20018-002	GROUNDING PIN	1
2	B15003-001	FLANGE NUT 3/8-16	2
1	A20329-001	2.5" AL PIPE U-BOLT	1

MATERIAL		<b>SEE NOTES</b>	
Third Angle Projection:			
GENERAL SPECIFICATIONS		<b>SunModo Corp.</b> 14800 NE 65TH STREET, VANCOUVER WA 98682	
Tolerances		TITLE	
X.XXX ±0.01 [0.25mm] X.XX ±0.02 [0.50mm] X.X ±0.039 [1.0mm] Unless otherwise spec'd		2.5" AL PIPE U-CLAMP KIT	
DRAWN BY	DATE	DRAWING NUMBER	
KYY	06/12/2018	B K10343-001	
CHECKED BY		SCALE: NONE SHEET 1 of 1	
APPROVALS			

THIS DRAWING IS CONFIDENTIAL PROPERTY OF SUNMODO AND ITS CONTENTS MAY NOT BE DISCLOSED WITHOUT THE PRIOR WRITTEN CONSENT OF SUNMODO CORP.

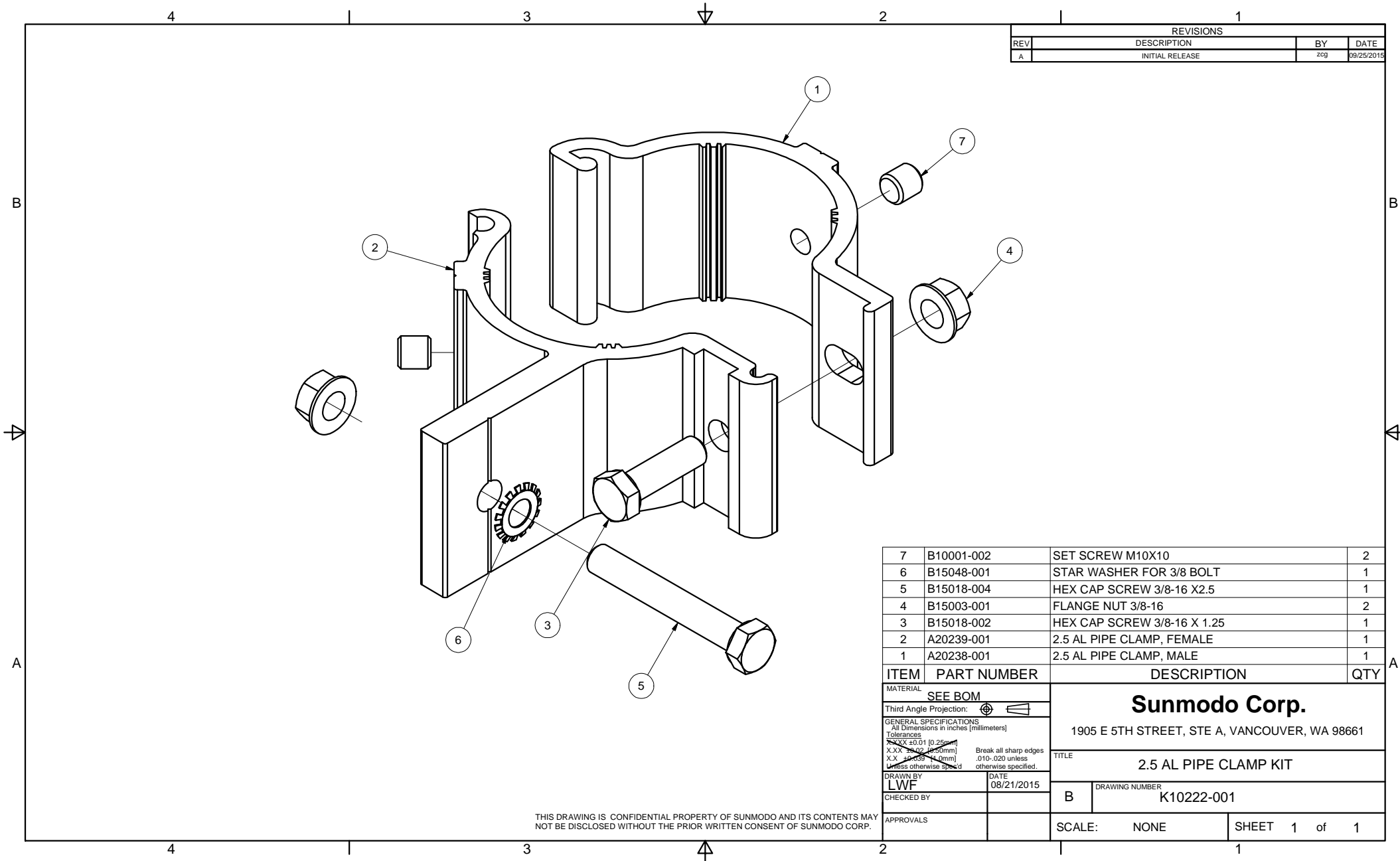

REVISIONS			
REV	DESCRIPTION	BY	DATE
A	INITIAL RELEASE	zcg	09/25/2015

ITEM	PART NUMBER	DESCRIPTION	QTY
7	B10001-002	SET SCREW M10X10	2
6	B15048-001	STAR WASHER FOR 3/8 BOLT	1
5	B15018-004	HEX CAP SCREW 3/8-16 X2.5	1
4	B15003-001	FLANGE NUT 3/8-16	2
3	B15018-002	HEX CAP SCREW 3/8-16 X 1.25	1
2	A20239-001	2.5 AL PIPE CLAMP, FEMALE	1
1	A20238-001	2.5 AL PIPE CLAMP, MALE	1

MATERIAL		SEE BOM	
Third Angle Projection:			
<b>GENERAL SPECIFICATIONS</b> All Dimensions in inches [millimeters] <b>Tolerances</b> X.XX ±0.01 [0.25mm] X.XX ±0.02 [0.50mm] X.X ±0.03 [0.75mm] Unless otherwise specified.			
DRAWN BY		DATE	
LWF		08/21/2015	
CHECKED BY		B	
APPROVALS		SCALE: NONE	
		SHEET 1 of 1	

**Sunmodo Corp.**  
 1905 E 5TH STREET, STE A, VANCOUVER, WA 98661

TITLE  
**2.5 AL PIPE CLAMP KIT**

DRAWING NUMBER  
**K10222-001**

THIS DRAWING IS CONFIDENTIAL PROPERTY OF SUNMODO AND ITS CONTENTS MAY NOT BE DISCLOSED WITHOUT THE PRIOR WRITTEN CONSENT OF SUNMODO CORP.

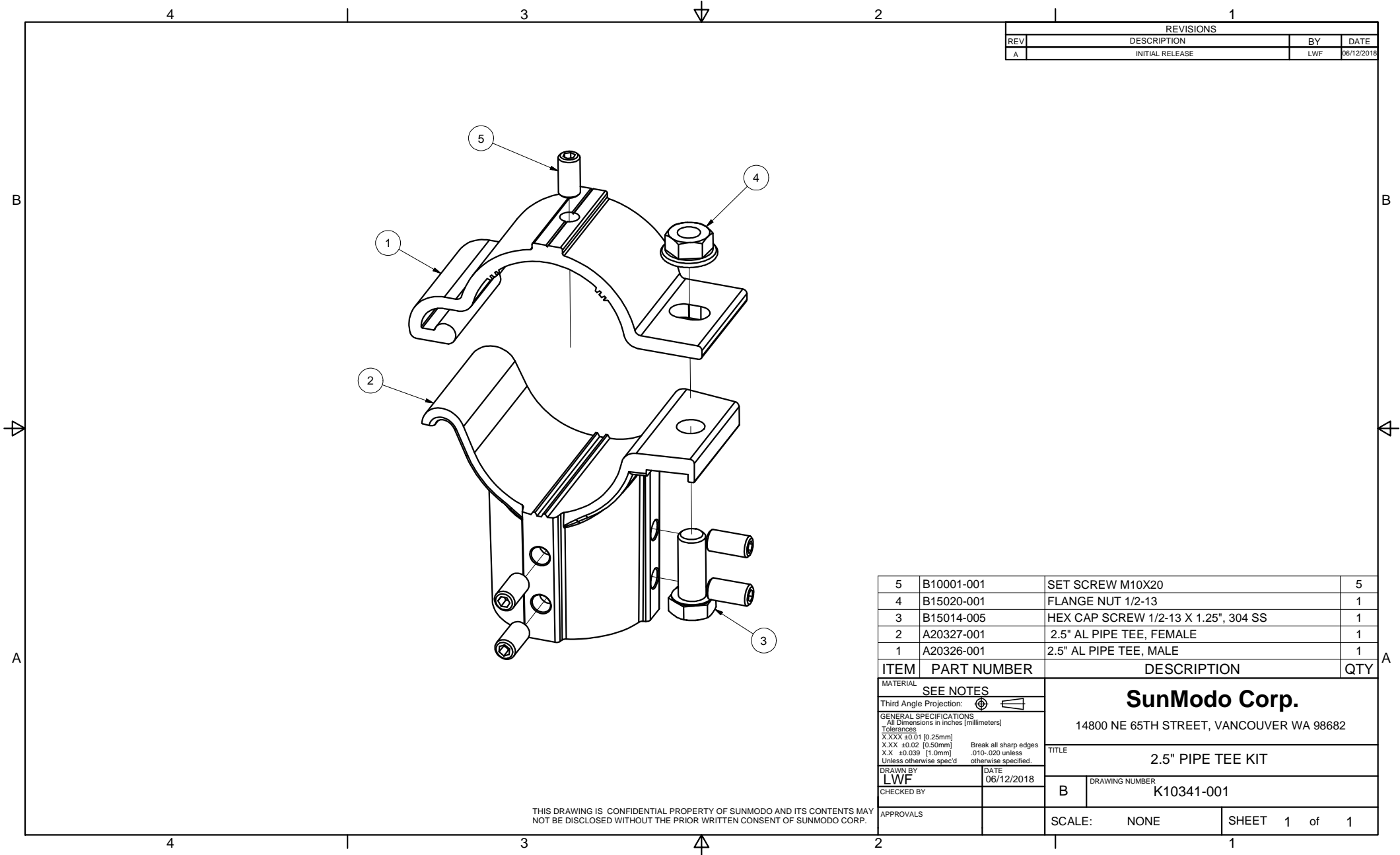

REVISIONS			
REV	DESCRIPTION	BY	DATE
A	INITIAL RELEASE	LWF	06/12/2018

ITEM	PART NUMBER	DESCRIPTION	QTY
5	B10001-001	SET SCREW M10X20	5
4	B15020-001	FLANGE NUT 1/2-13	1
3	B15014-005	HEX CAP SCREW 1/2-13 X 1.25", 304 SS	1
2	A20327-001	2.5" AL PIPE TEE, FEMALE	1
1	A20326-001	2.5" AL PIPE TEE, MALE	1

MATERIAL		SEE NOTES	
Third Angle Projection:			
GENERAL SPECIFICATIONS		<b>SunModo Corp.</b> 14800 NE 65TH STREET, VANCOUVER WA 98682	
Tolerances		TITLE	
X.XXX ±0.01 [0.25mm] X.XX ±0.02 [0.50mm] X.X ±0.039 [1.0mm] Unless otherwise spec'd		2.5" PIPE TEE KIT	
DRAWN BY		DATE	
LWF		06/12/2018	
CHECKED BY		DRAWING NUMBER	
		B K10341-001	
APPROVALS		SCALE: NONE SHEET 1 of 1	

THIS DRAWING IS CONFIDENTIAL PROPERTY OF SUNMODO AND ITS CONTENTS MAY NOT BE DISCLOSED WITHOUT THE PRIOR WRITTEN CONSENT OF SUNMODO CORP.

REVISIONS			
REV	DESCRIPTION	BY	DATE
A	INITIAL RELEASE	LWF	06/12/2018

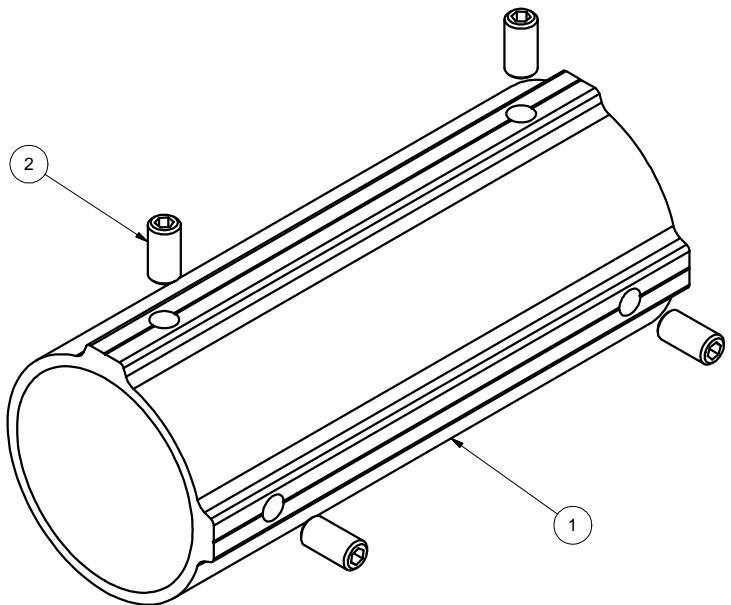

2	B10001-001	SET SCREW M10X20	4
1	A20328-001	2.5" PIPE SPLICE	1
ITEM	PART NUMBER	DESCRIPTION	QTY
MATERIAL		SEE NOTES	
Third Angle Projection:			
GENERAL SPECIFICATIONS		<b>SunModo Corp.</b> 14800 NE 65TH STREET, VANCOUVER WA 98682	
All Dimensions in inches [millimeters] Tolerances X.XXX ±0.01 [0.25mm] X.XX ±0.02 [0.50mm] X.X ±0.039 [1.0mm] Unless otherwise spec'd		Break all sharp edges .010-.020 unless otherwise specified.	
DRAWN BY		TITLE	
LWF		2.5" PIPE SPLICE KIT	
CHECKED BY		DRAWING NUMBER	
		B K10342-001	
APPROVALS		SCALE: NONE SHEET 1 of 1	

THIS DRAWING IS CONFIDENTIAL PROPERTY OF SUNMODO AND ITS CONTENTS MAY NOT BE DISCLOSED WITHOUT THE PRIOR WRITTEN CONSENT OF SUNMODO CORP.



NOTES: UNLESS OTHERWISE SPECIFIED

1. DIMENSIONS SHOWN ARE INCHES [MILIMETERS].
2. MATERIAL:HIGH STRENGTH STEEL PIPE OR TUBE.
3. FINISH: HOT DIP GALVANIZE PER ASTM A123 / A123M - 02.

MINIMUM 50 KSI YIELD STRESS.

4. BREAK ALL BURRS AND SHARP EDGES.

5. ALL WELDING MUST BE IN COMPLIANCE WITH AWS CODE D1;1.

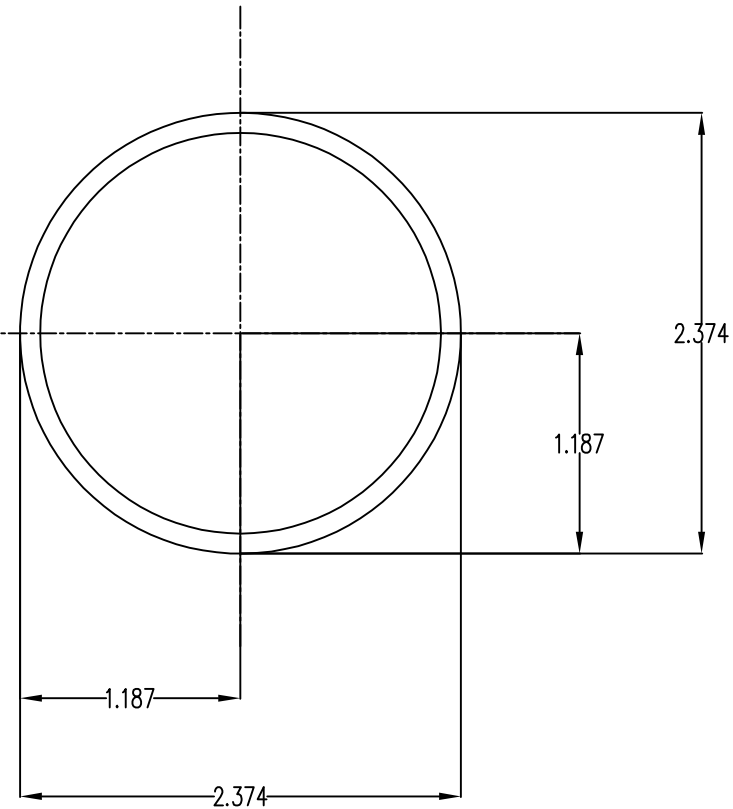

## Section properties:

Weight: 2.641 lbs/ft

Area: 0.776 in<sup>2</sup>

Perimeter: 14.238 in

Bounding Box: X: -1.187,1.187

Y: -1.187,1.187

Centroid:(0.000,0.000)

Moments of Inertia(in<sup>4</sup>): Ix=0.499,Iy=0.499

Section modulus in bending(in<sup>3</sup>): Wx=0.420,Wy=0.420

Radii of Gyration: X: 0.802, Y: 0.802

MATERIAL		SEE NOTES		<b>Sunmodo Corp.</b> 14800 NE 85TH STREET, VANCOUVER WA 98682	
Third Angle Projection:					
GENERAL SPECIFICATIONS				TITLE	
All Dimensions in Inches (millimeters)				PIPE, HSS, 2.375" OD X 12 GAUGE,L=XXX	
Tolerances				Break all sharp edges .010-.020 unless otherwise specified.	
XXX ±0.01 (0.25mm)					
XX ±0.02 (0.50mm)					
X ±0.050 (1.2mm)					
Unless otherwise specified					
DRAWN BY	DATE	B		DRAWING NUMBER	
LWF	04/03/2019			A21165	
CHECKED BY					
APPROVALS				SCALE: NONE SHEET 1 of 1	

NOTES: UNLESS OTHERWISE SPECIFIED

1. DIMENSIONS SHOWN ARE INCHES [MILIMETERS].
2. MATERAIL:HIGH STRENGTH STEEL PIPE OR TUBE.
3. FINISH: HOT DIP GALVANIZE PER ASTM A123 / A123M - 02.

MINIMUM 50 KSI YIELD STRESS.

4. BREAK ALL BURRS AND SHARP EDGES.
5. ALL WELDING MUST BE IN COMPLIANCE WITH AWS CODE D1;1.

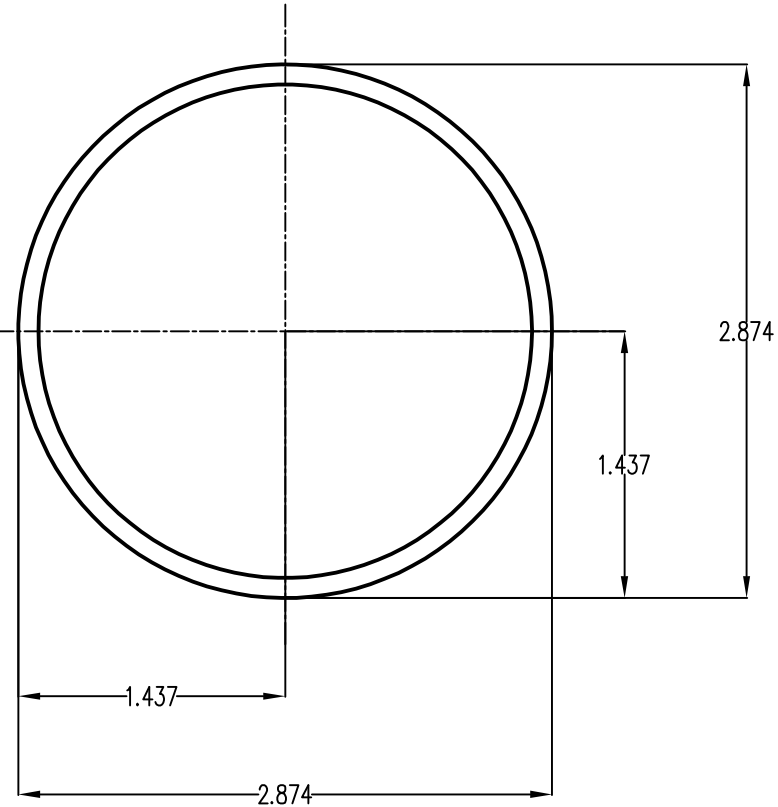

### Section properties:

Weight: 3.201 lbs/ft

Area: 0.941 in<sup>2</sup>

Perimeter: 17.378 in

Bounding Box: X: -1.437,1.437

Y: -1.437,1.437

Centroid:(0.000,0.000)

Moments of Inertia(in<sup>4</sup>): Ix=0.901,Iy=0.901

Section modulus in bending(in<sup>3</sup>): Wx=0.627,Wy=0.627

Radii of Gyration: X: 0.979, Y: 0.979

MATERIAL		SEE NOTES		<b>Sunmodo Corp.</b> 14800 NE 85TH STREET, VANCOUVER WA 98682	
Third Angle Projection:					
GENERAL SPECIFICATIONS All Dimensions in Inches (millimeters)				TITLE	
Tolerances XXX ±0.01 (0.25mm) XX ±0.02 (0.50mm) X ±0.030 (1.0mm) Unless otherwise specified				PIPE, HSS, 2.875" OD X 12 GAUGE,L=XXX	
DRAWN BY LWF		DATE 04/03/2019		DRAWING NUMBER A21168	
CHECKED BY				B	
APPROVALS				SCALE: NONE SHEET 1 of 1	