



Project Number: U2716-099-191

July 31, 2019

Sunmodo  
14800 NE 65<sup>th</sup> Street  
Vancouver, WA 98682

**REFERENCE: Sunmodo Sunturf Ground Mount C3  
Ground Mount PV Array Installation**

To Whom It May Concern:

Per request of Sunmodo, we have been asked to prepare the structural design of a ground-mounted PV solar array system with several foundation options as shown in the attached calculations. The adopted building code in this jurisdiction is the 2019 California Building Code (2018 IBC). Vector Structural Engineering requires that we review each site specific install, and we are not liable for installs at site specific locations we have not reviewed. The following design parameters are used in our analysis:

- Minimum Design Loads for Buildings and Other Structures (ASCE 7-16)
- Design wind speed for risk category I structures: 100 mph
- Wind exposure: C
- Ground snow load: 0 psf
- The ground screws and helical piers must be tested to 1.5 times uplift and 2.0 times lateral reactions found in the table below. A minimum of one ground screw or helical pier must be tested.

Load (ASD)	Value (lbs)	Factor of Safety	Test Value (lbs)
UPLIFT	2360	1.5	3540
LATERAL	1580	2	3160

Foundation concrete shall have a minimum compressive strength of 2500 psi at 28 days. Cement for all concrete shall be Type I or II with a water/cement ratio of 0.50. Maximum aggregate size shall be 3/4". No special inspection of concrete strength is required.

Footings are designed based on an allowable soil bearing pressure of 1500 psf an allowable skin friction of 250 psf, an allowable lateral bearing pressure of 150 pcf, and a coefficient of friction of 0.3. Vector Structural Engineering strongly recommends independent soils testing be performed by a licensed geotechnical engineer to verify the assumed soil parameters.

All ground mounts are to be installed per manufacturer’s recommendations. The use of solar panel support span tables provided by the manufacturer is allowed only where the site conditions and solar panel configuration match the description of the span tables. Electrical engineering is beyond our scope. All work performed must be in accordance with accepted industry-wide methods and applicable safety standards. Vector Structural Engineering assumes no responsibility for improper installation of the solar panels.

Very truly yours,

VECTOR STRUCTURAL ENGINEERING, LLC

\_\_\_\_\_  
Russell Emery, P.E.  
License: C73566 - Expires: 12/31/2020  
Project Engineer



Enclosures

RNE/stb

07/31/2019



JOB NO. U2716-099-191  
 PROJECT SUNMODO SUNTURF GROUND MOUNTS C3  
 SUBJECT ALL OPTIONS

651 W GALENA PARK BLVD. #101 (801) 990-1775  
 DRAPER, UTAH 84020 (801) 990-1776 FAX

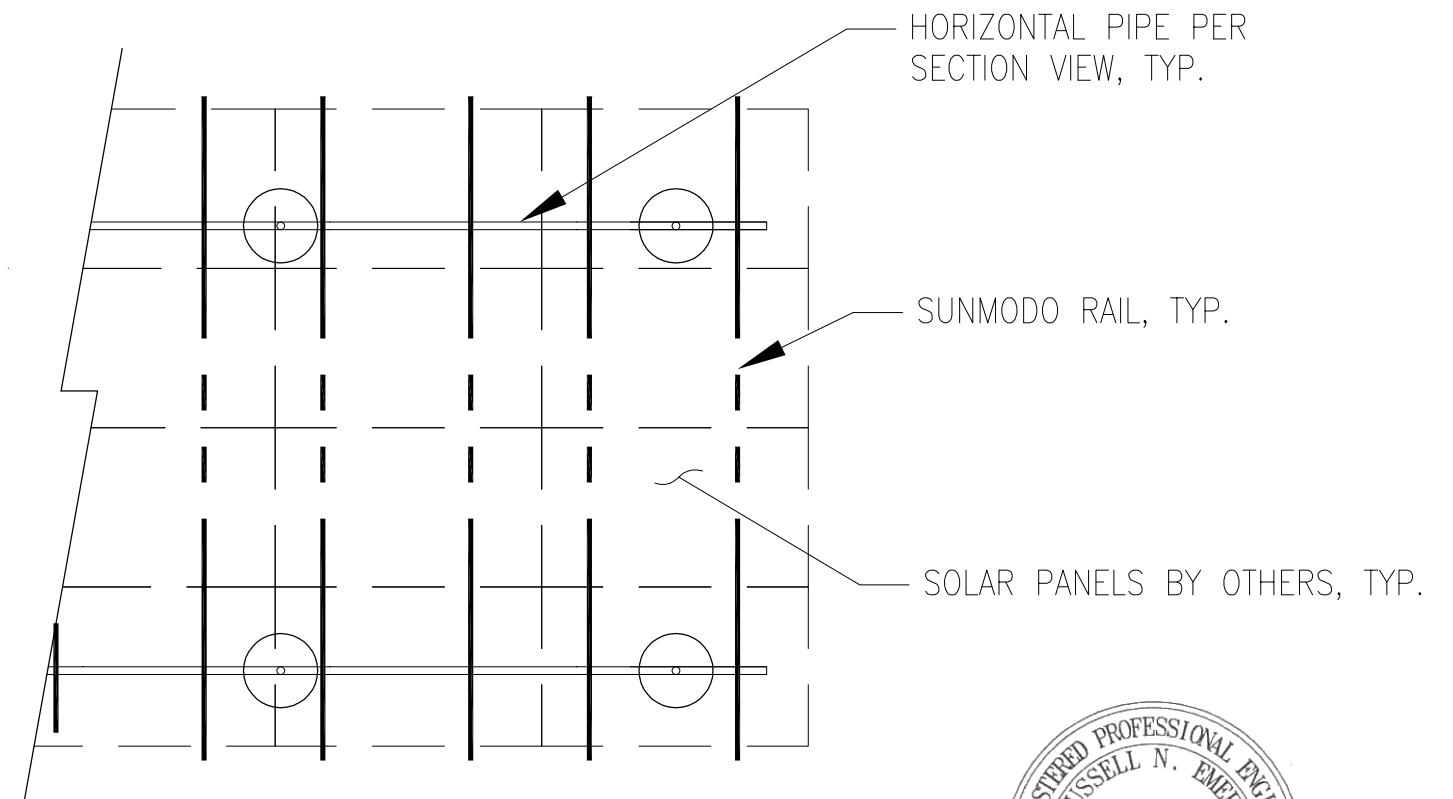
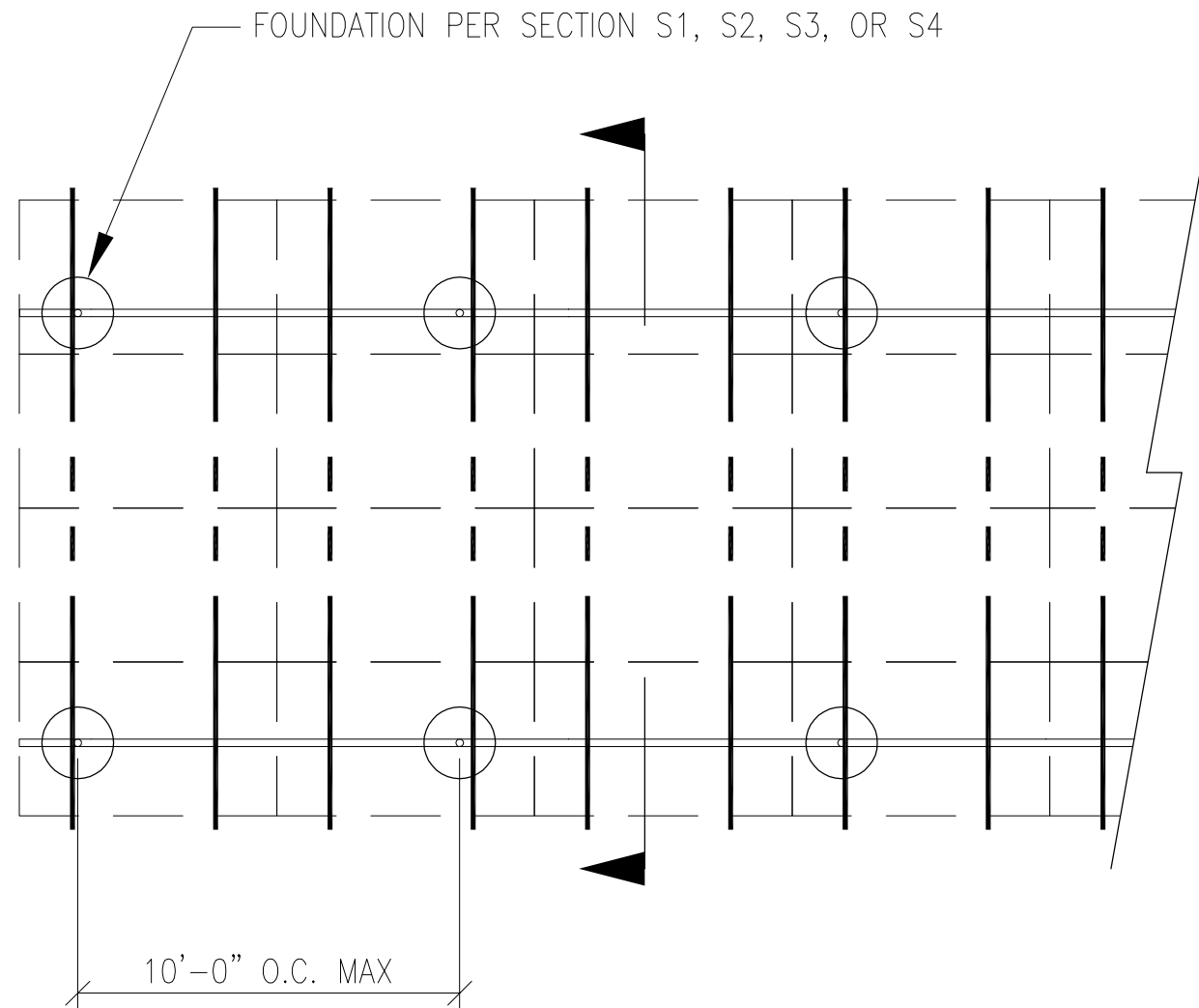

07/29/2019

**PV ARRAY PLAN**

N.T.S.

**P1**

Vector Engineers requires that we review each site specific install and is not liable for installs at site specific locations we have not reviewed.

PROJECT SUNMODO SUNTURF GROUND MOUNTS C3

SUBJECT DRILLED PIER OPTION

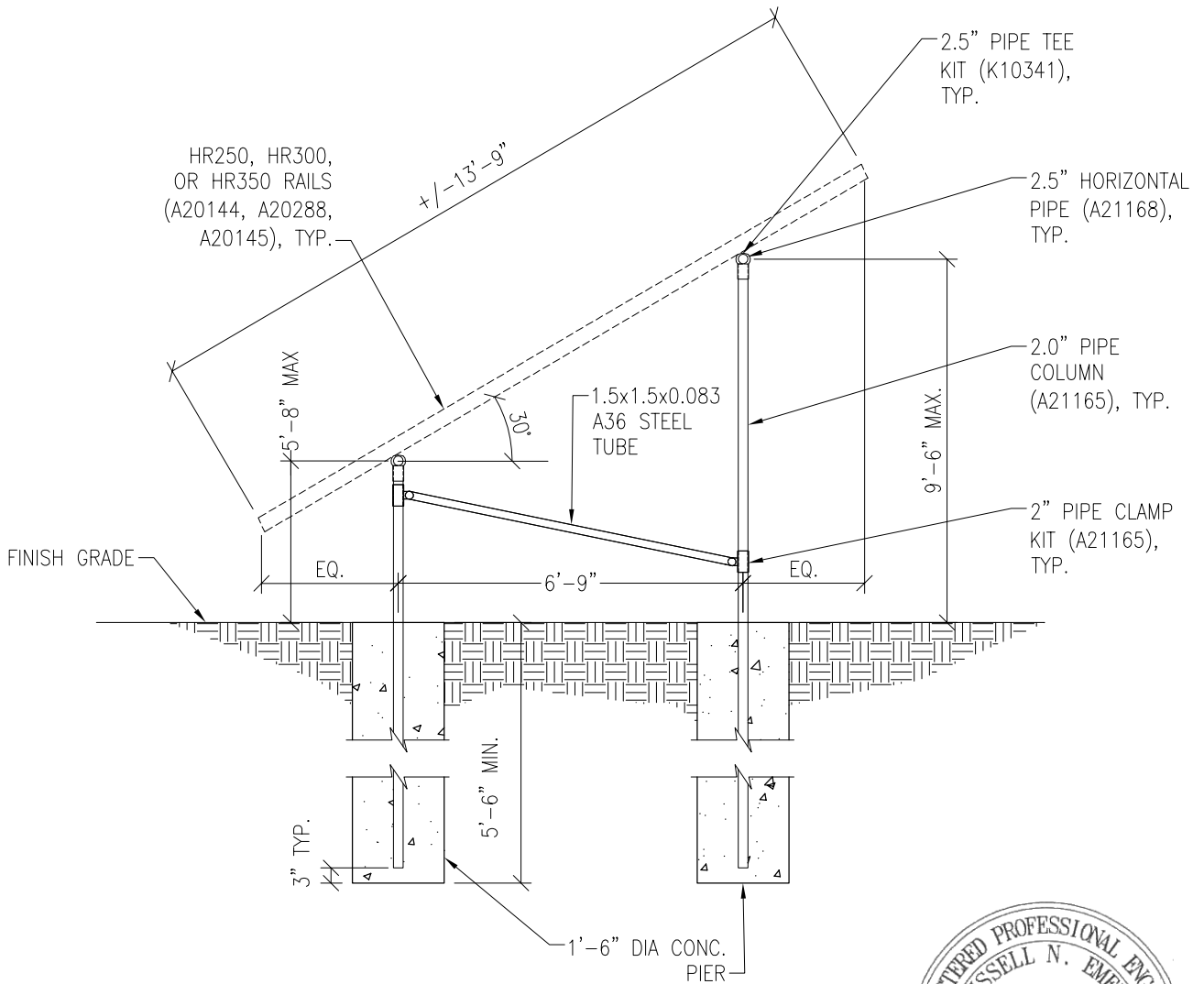

Vector Engineers requires that we review each site specific install and is not liable for installs at site specific locations we have not reviewed.

**PV ARRAY SECTION**

**07/29/2019**

**S1**

N.T.S.

PROJECT SUNMODO SUNTURF GROUND MOUNTS C3

SUBJECT HELICAL PIER OPTION

**NOTES:**

1. For ground mount components see Section S1.
2. A minimum of (1) helical pier must be load-tested as follows:
  - 2.1. Safety factor for uplift = 1.5,
  - 2.2. Safety factor for lateral loads = 2.0
  - 2.3. Upward deflection limit = 1/2"
  - 2.4. Lateral deflection limit = 1"
  - 2.5. The load tests must be performed by an approved contractor.

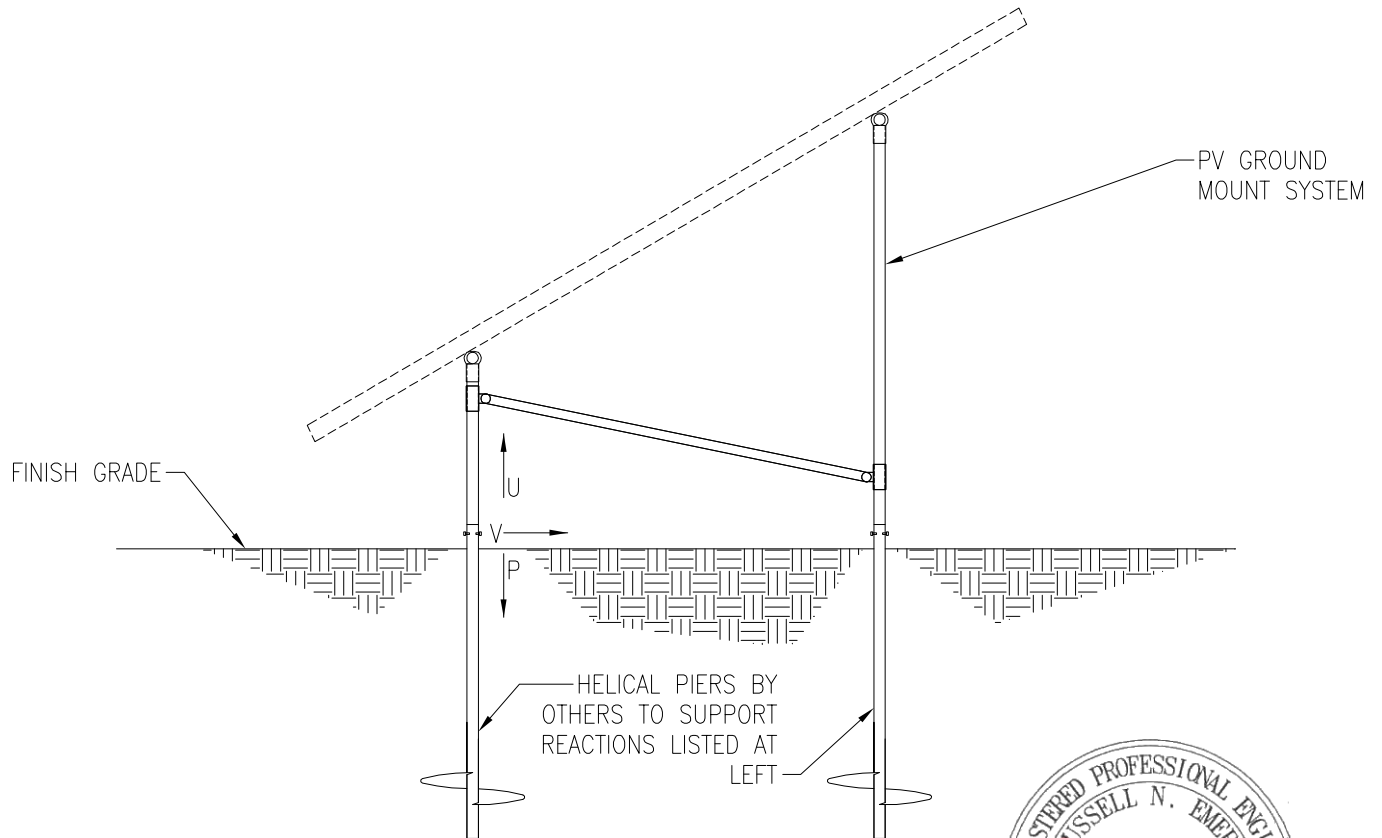

<b>MAXIMUM REACTIONS:</b>	
U	= 2,360 LBS
P	= 2,930 LBS
V	= 1,580 LBS



03/26/2020

**PV ARRAY SECTION**

N.T.S.

**S2**

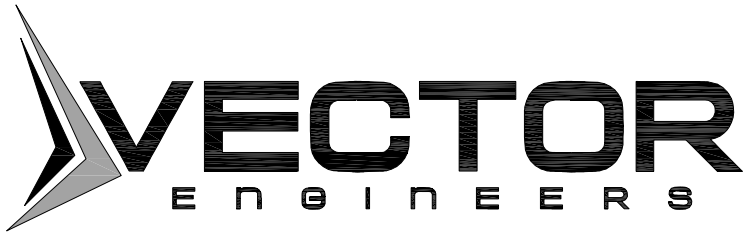

JOB NO. U2716-099-191

PROJECT SUNMODO SUNTURF GROUND MOUNTS C3

SUBJECT GROUND SCREW OPTION

NOTES:

- 1. For ground mount components see Section S1.
- 2. A minimum of (1) ground screw must be load-tested as follows:
  - 2.1. Safety factor for uplift = 1.5,
  - 2.2. Safety factor for lateral loads = 2.0
  - 2.3. Upward deflection limit = 1/2"
  - 2.4. Lateral deflection limit = 1"
  - 2.5. The load tests must be performed by an approved contractor.

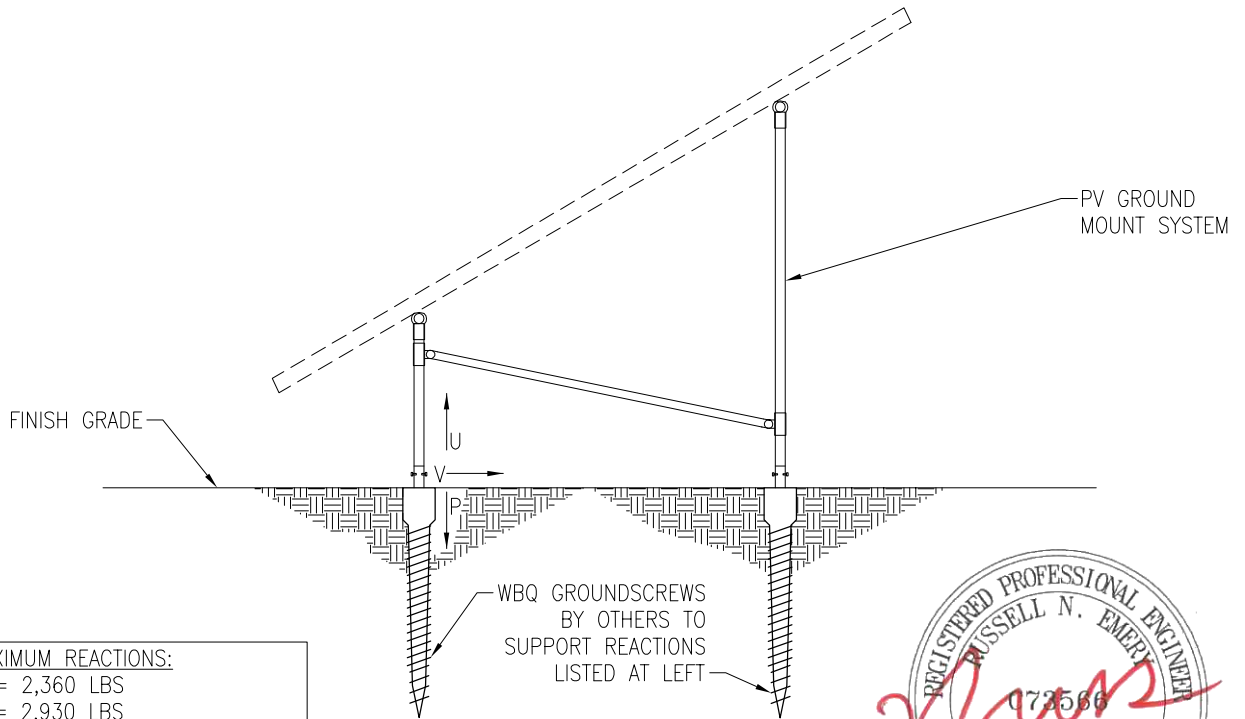

MAXIMUM REACTIONS:  
 U = 2,360 LBS  
 P = 2,930 LBS  
 V = 1,580 LBS



PV ARRAY SECTION

03/26/2020

N.T.S.

S3

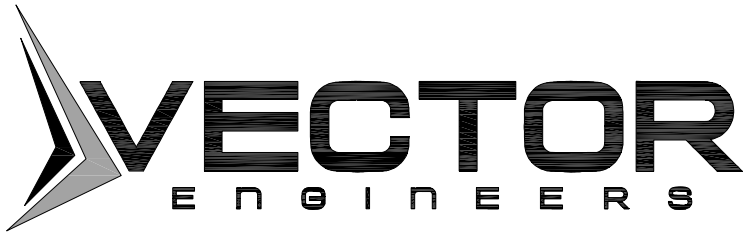

JOB NO. U2716-099-191

PROJECT SUNMODO SUNTURF GROUND MOUNTS C3

SUBJECT BALLASTED BLOCK OPTION

NOTES:

1. For ground mount components see Section S1.

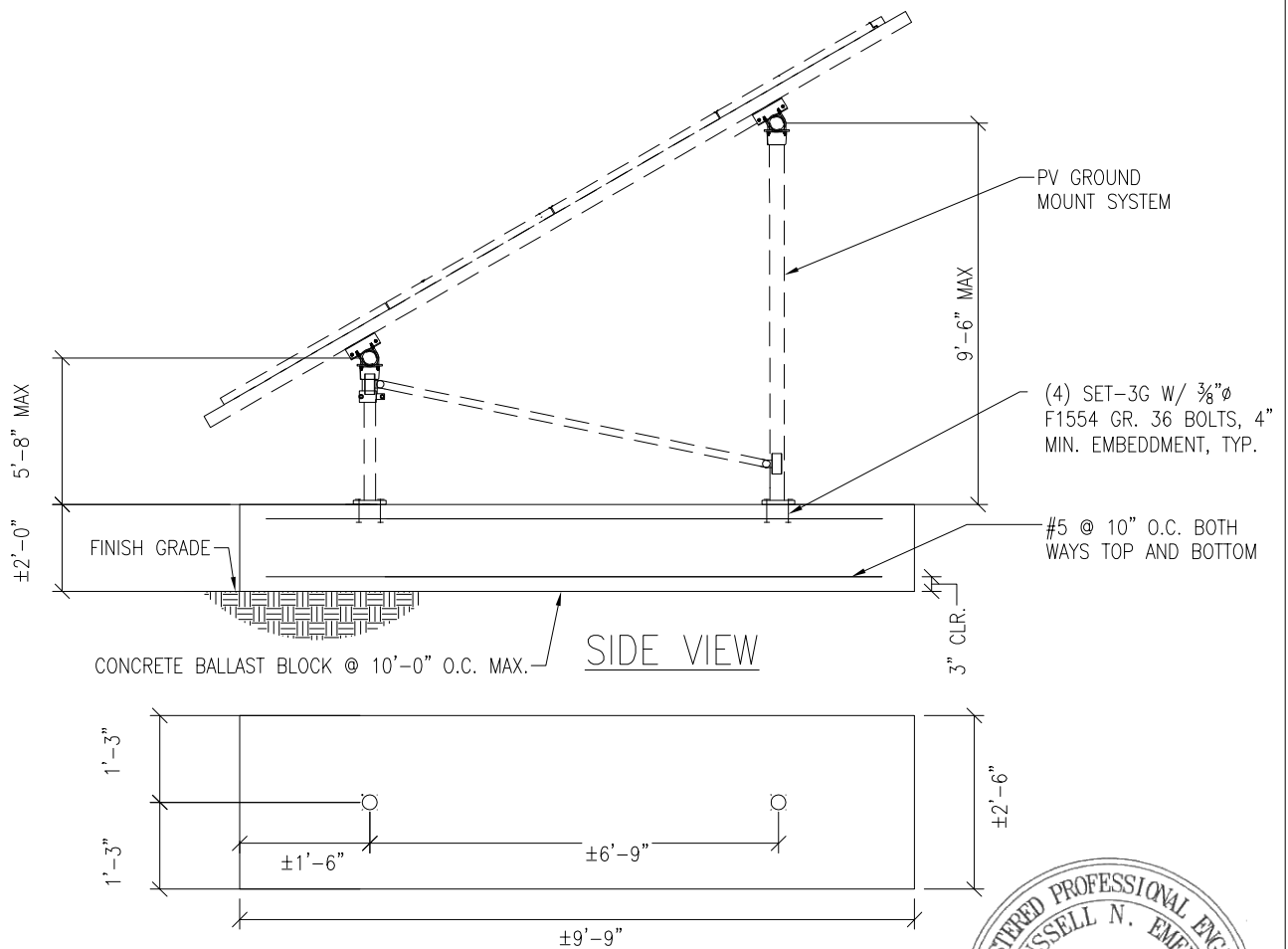

Vector Engineers requires that we review each site specific install and is not liable for installs at site specific locations we have not reviewed.

**PV ARRAY SECTION**

**07/29/2019**

**S4**

N.T.S.

651 W GALENA PARK BLVD. #101  
 DRAPER, UTAH 84020

(801) 990-1775  
 (801) 990-1776 FAX

WWW.VECTORSE.COM

PROJECT: C3 – Sunmodo Sunturf GM

SUBJECT: Dead Load

**Design Weight:**

Individual Panel Weight [lb]:	50.7
Panel Transverse Length (T5) [in]:	41.2
Panel Transverse Length (T5) [ft]:	3.4
Panel Longitudinal Length (L2) [in]:	81.4
Panel Longitudinal Length (L2) [ft]:	6.8
Individual Panel Area [ft <sup>2</sup> ]:	23.3
Individual Panel Weight [psf]:	2.2
# of Panels in Transverse Direction:	4
Approximate Transverse Length (T4) [ft]:	13.7
# of Panels in Longitudinal Direction:	12
Approximate Longitudinal Length (L1) [ft]:	81.4
Transverse Column Spacing (T1) [ft]:	6.8
Longitudinal Column Spacing (L3) [ft]:	10.0
# of Columns in Longitudinal Direction:	9
# of Columns in Transverse Direction:	2
Total Number of Columns:	18
Panel Slope from Horizontal (a) [°]:	30.0
Short Column Height (H1) [ft]:	5.7
Approximate Tall Column Height (H2) [ft]:	9.6
Transverse Brace between Columns :	Yes
Approximate Brace Length (B1) [ft]:	9.0
Weight of Columns [plf]:	3.7
Weight of Cross Pipe [plf]:	3.7
Weight of Brace [plf]:	3.7
Tributary Transverse Length per Column [ft]:	6.9
Tributary Longitudinal Length per Column [ft]:	10.0
Tributary Area per Column [ft <sup>2</sup> ]:	68.7
Rail Weight [plf]:	1.0
Transverse Rail Weight per Column [lb]:	27.5
Longitudinal Rail Weight per Column [lb]:	36.5
Tall Column Weight [lb]:	35.1
Panel Weight per Column [lb]:	149.5
Rail Weight per Column [lb]:	27.5
Cross Pipe Weight per Column [lb]:	36.5
Brace Weight per Column [lb]:	16.4
<b>Total Weight per Column (1.0 D) [lb]:</b>	<b>265.0</b>

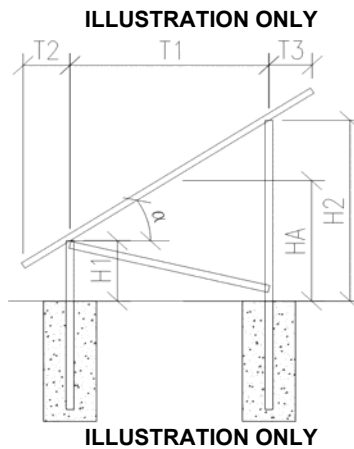
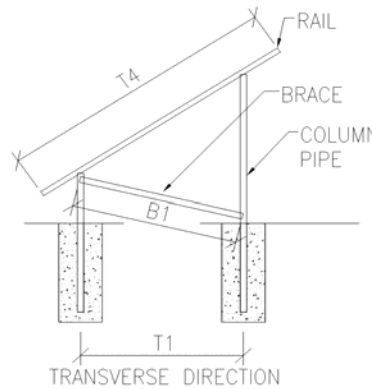
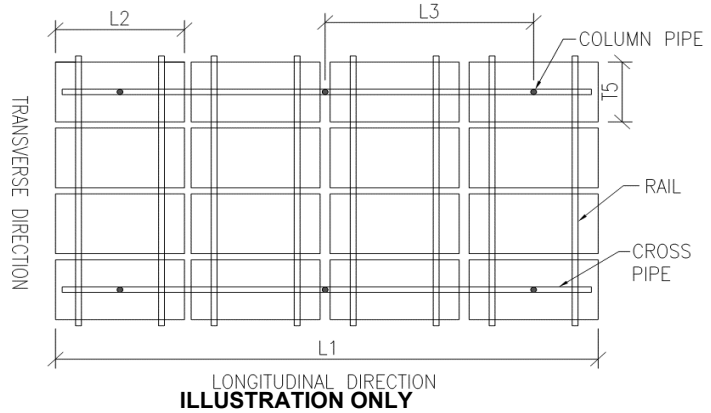

**Assumptions:**

- T2 = T3



JOB NO.: U2716-099-191

DESIGNED: STB

DATE: 07/29/19

PROJECT: C3 – Sunmodo Sunturf GM

SUBJECT: Snow Load

**SNOW LOAD (S):**

ASCE 7 Standard:	16	
Panel Slope from Horizontal [°]:	30.0	
Snow Ground Load, $p_g$ [psf]:	0.0	(Section 7.2)
Terrain Category:	C	(Table 7-2)
Exposure of Roof:	Fully Exposed	(Table 7-2)
Exposure Factor, $C_e$ :	0.9	(Table 7-2)
Thermal Factor, $C_t$ :	1.2	(Table 7-3)
Risk Category:	I	(Table 1.5-1)
Importance Factor, $I_s$ :	0.8	(Table 1.5-2)
Flat Roof Snow Load, $p_f$ [psf]:	0	(Equation 7.3-1)
Minimum Roof Snow Load, $p_m$ [psf]:	0	(Section 7.3.4)
Unobstructed Slippery Surface?	Yes	(Section 7.4)
Slope Factor Figure:	Figure 7-2c	(Section 7.4)
Roof Slope Factor, $C_s$ :	0.727	(Figure 7-2)
Sloped Roof Snow Load, $p_s$ [psf]:	0	(Equation 7.4-1)
Design Snow Load, $S$ [psf]:	0	
Tributary Transverse Length [ft]:	5.9	
Tributary Longitudinal Length [ft]:	10	
Tributary Area per Column [ft <sup>2</sup> ]:	59.5	
<b>Snow Load per Column (1.0 S) [lb]:</b>	<b>0.0</b>	





PROJECT: C3 – Sunmodo Sunturf GM

SUBJECT: Wind Pressure

**Design Wind Load:**

ASCE 7 Standard:	16	
Basic Wind Speed, V [mph]:	100	
Risk Category:	I	
Exposure Category	C	(Section 26.7.3)
Velocity Pressure Exposure Coefficient, $K_h$ :	0.85	(Table 26.10-1)
Topographic Factor, $K_{ht}$ :	1.0	(Section 26.8.2)
Wind Directionality Factor, $K_d$ :	0.85	(Table 26.6-1)
Internal Pressure Coefficient, $GC_{pi}$ :	0.00	(Table 26.13-1)
Velocity Pressure, $q_h$ [psf]:	18.5	(Equation 26.10-1)
Gust Effect Factor, G:	0.85	(Section 26.11.1)
Panel Slope [degrees]:	30.0	

Net Pressure Coefficients ( $C_N$ ) per: (Figure 27.3-4)

Clear Wind Flow	$C_{NW}$	$C_{NL}$
Case 1 ( $\gamma = 0^\circ$ , Load Case A)	-1.80	-1.80
Case 2 ( $\gamma = 0^\circ$ , Load Case B)	-2.50	-0.50
Case 3 ( $\gamma = 180^\circ$ , Load Case A)	2.10	2.10
Case 4 ( $\gamma = 180^\circ$ , Load Case B)	2.60	1.00

Design Wind Pressures (p) [psf] per: (Equation 27.3-2)

Clear Wind Flow	$q_h GC_{NW}$	$q_h GC_{NL}$
Case 1 ( $\gamma = 0^\circ$ , Load Case A)	-28.3	-28.3
Case 2 ( $\gamma = 0^\circ$ , Load Case B)	-39.3	-7.9
Case 3 ( $\gamma = 180^\circ$ , Load Case A)	33.0	33.0
Case 4 ( $\gamma = 180^\circ$ , Load Case B)	40.9	15.7

Wind Pressure on Each Side of Panels [psf]

Clear Wind Flow	Short Col. Pressure	Long Col. Pressure
Case 1 ( $\gamma = 0^\circ$ , Load Case A)	-28.3	-28.3
Case 2 ( $\gamma = 0^\circ$ , Load Case B)	-7.9	-39.3
Case 3 ( $\gamma = 180^\circ$ , Load Case A)	33.0	33.0
Case 4 ( $\gamma = 180^\circ$ , Load Case B)	40.9	15.7



JOB NO.: U2716-099-191

PROJECT: C3 – Sunmodo Sunturf GM

SUBJECT: Open Building Wind Loads

### Design Wind Load Per ASCE 7-16

$$p = q_h G C_n$$

Velocity Pressure Exposure Coefficient, $K_z$ :	0.85	(Table 26.10-1)
Topographic Factor, $K_{zt}$ :	1.0	(Section 26.8.2)
Wind Directionality Factor, $K_d$ :	0.85	(Table 26.6-1)
Ultimate Wind Speed, $V$ [mph]:	100	

Velocity Pressure, $q_h$ [psf]:	18.5	(Equation 26.10-1)
Gust Effect Factor, $G$ :	0.85	(Section 26.11.1)

$\gamma = 90^\circ$  or  $270^\circ$

Force Coefficient,  $C_N$ :

Horizontal Distance from Winward Edge	Roof angle		
	Load Case	Obstructed Wind Flow	
		CN	
$\leq h$	30	A	-0.8
		B	0.8
$> h, \leq 2h$	30	A	-0.6
		B	0.5
$> 2h$	30	A	-0.3
		B	0.3

Design Wind Pressure,  $p$  [psf]:

	Roof angle		
	Load Case	Obstructed Wind Flow	
$\leq h$	30	A	-12.6
		B	12.6
$> h, \leq 2h$	30	A	-9.4
		B	7.9
$> 2h$	30	A	-4.7
		B	4.7



JOB NO.: U2716-098-191

DESIGNED: STB

---

# Foundation Option 1: Drilled Concrete Pier



JOB NO.: U2716-099-191  
DATE: 07/29/19

DESIGNED: STB

PROJECT: C3 – Sunmodo Sunturf GM

**Drilled Pier Design**

**Design Loads:**

Max. Shear, V [k]:	1.6	Max. Down, P <sub>d</sub> [k]:	2.9
Max. Moment, M [k-ft]:	0.0	Max. Uplift, P <sub>u</sub> [k]:	2.4

**Pier Properties:**

Pier Diameter, b [ft]:	1.5	Volume of Concrete [ft <sup>3</sup> ]:	10
Min. Pier Diameter, b <sub>min</sub> (opt'l) [ft]:		Volume of Concrete [yd <sup>3</sup> ]:	0.4
Top of Pier Elevation [ft]:	0.00	Weight of Concrete [k]:	1.5
Pier Depth, d [ft]:	5.5		
Min. Pier Depth, d <sub>min</sub> (opt'l) [ft]:			
Max. Pier Depth, d <sub>max</sub> (opt'l) [ft]:			

**Soil Properties:**

Allow. Bearing Pressure [psf]:	1,500	<u>Optional Parameters for Uplift:</u>	
1/3 increase for short term loads?	No	Skin Friction [psf]:	250 (IBC 1810.3.3.1.4)
Lateral Bearing, S [pcf]:	150	Top Length to Ignore [ft]:	0.0
Max. Lateral Bearing (opt'l) [psf]:		1/3 increase for short term loads?	No
Top Depth to Ignore [ft]:	0.0	Combine w/ Bearing:	No
1/3 increase for short term loads?	No		
1/2" deflection at t/o pier allowed:	Yes		

**Check Bearing:**

Bearing Capacity [k]: 6.5      **Bearing capacity OK.**

**Check Uplift:**

Uplift Capacity [k]: 7.8      **Uplift capacity OK.**

**Check Lateral Bearing:**

Applied Lateral Force, P [lb]:	1,580	
Point of Application, h [ft]:	0.0	
S <sub>1_max</sub> [psf]:		
S <sub>1</sub> [psf]:	550	
A = 2.34*P/(S <sub>1</sub> b):	4.48	
Required Pier Depth, d <sub>reqd</sub> [ft]:	4.5	<b>Lateral bearing capacity OK.</b>

# Foundation Option 2: Helical Pier

The ground screws and helical piers must be tested to 1.5 times uplift and 2.0 times lateral reactions found in the table below.

Load (ASD)	Value (lbs)	Factor of Safety	Test Value (lbs)
UPLIFT	2360	1.5	3540
LATERAL	1580	2	3160

# Foundation Option 3: Ground Screw

The ground screws and helical piers must be tested to 1.5 times uplift and 2.0 times lateral reactions found in the table below.

Load (ASD)	Value (lbs)	Factor of Safety	Test Value (lbs)
UPLIFT	2360	1.5	3540
LATERAL	1580	2	3160



JOB NO.: U2716-099-191

DESIGNED: STB

---

# Foundation Option 4: Ballasted Block

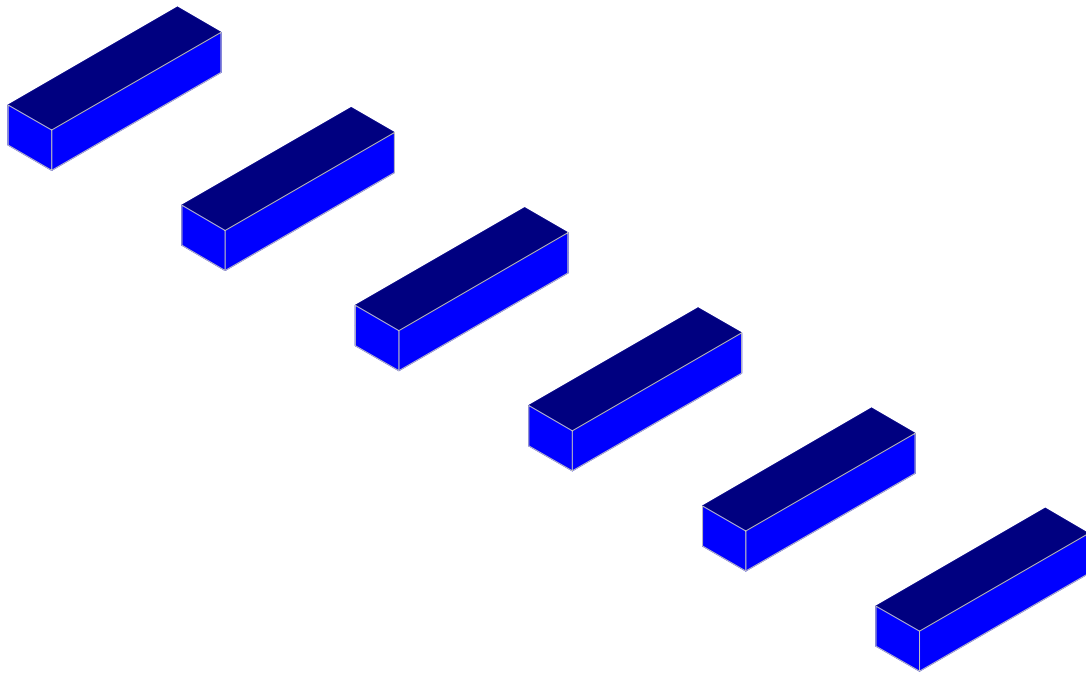

Results for LC 1, 1.0 D

Vector Structural Engineeri..	Ground Mount	SK - 13
STB		May 8, 2019 at 2:57 PM
U2716.098.191		California C1 GM - 81 in panels.r3d



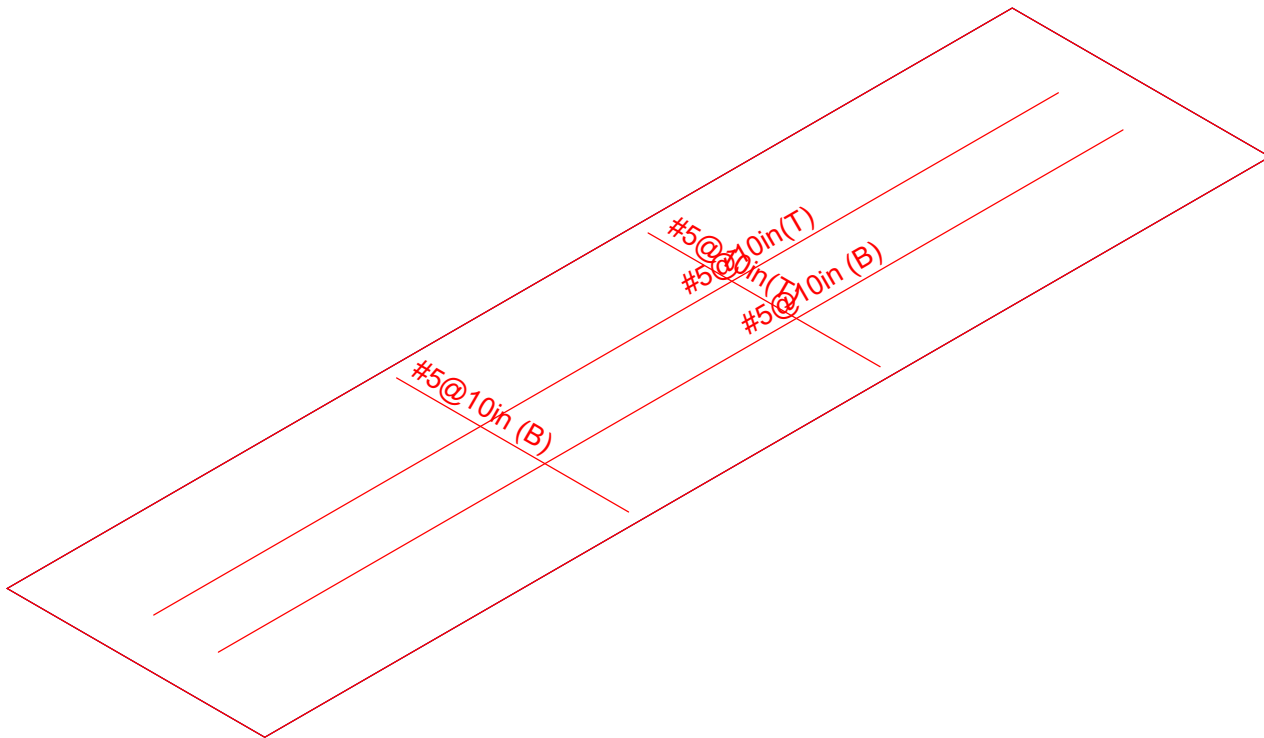

Results for LC 1, 1.0 D

Vector Structural Engineeri..	Ground Mount	SK - 12
STB		May 8, 2019 at 2:56 PM
U2716.098.191		California C1 GM - 81 in panels.r3d



**(Global) Model Settings**

Display Sections for Member Calcs	5
Max Internal Sections for Member Calcs	100
Mesh Size (in)	12
Max Iterations	10
Merge Tolerance (in)	.12
Solver	Sparse Accelerated
Coefficient of Friction	.3
No. of Shear Regions	4
Shear Region Spacing Increment (in)	4
Min 1 Bar Dia Spacing for Beams?	No
Optimize footings for OTM / Sliding?	Yes
Parame Beta Factor	.65
Pile Safety Factor	3
Concrete Stress Block	Rectangular
Concrete Rebar Set	ASTM A615
Concrete Code	ACI 318-14
HR Steel Pile Code	AISC 14th(360-10): ASD
Wood Pile Code	AWC NDS-15: ASD

**Concrete Properties**

	Label	E [ksi]	G [ksi]	Nu	Therm (\...	Density[lb/ft^3]	fc[psi]	Lambda	Flex Stee...	Shear St...
1	Conc3000NW	3156	1372	.15	.6	145	3000	1	60000	60000
2	Conc3500NW	3409	1482	.15	.6	145	3500	1	60000	60000
3	Conc4000NW	3644	1584	.15	.6	145	4000	1	60000	60000
4	Conc3000LW	2085	907	.15	.6	109.999	3000	.75	60000	60000
5	Conc3500LW	2252	979	.15	.6	109.999	3500	.75	60000	60000
6	Conc4000LW	2408	1047	.15	.6	109.999	4000	.75	60000	60000
7	Conc2500NW	3156	1372	.15	.6	145	2500	1	60000	60000

**General Design Parameters**

	Label	Max Bending Chk	Max Shear Chk	Top Cover[in]	Bottom Cover[in]
1	Typical	1	1	3	3

**Slab Rebar Parameters**

	Label	Top Bar	Bottom Bar	Max Top Bar Sp...	Min Top Bar Sp...	Max Bot Bar Sp...	Min Bot Bar Sp...	Spacing Incr...	Rebar Options
1	Typical	#5	#5	10	10	10	10	1	Optimize

**Soil Definitions**

	Label	Subgrade Modulus[lb/ft^3]	Allowable Bearing[psf]	Depth Properties	Default?
1	Default	1e+5	1500	None	Yes

**Point Loads and Moments (Cat 1 : DL)**

	Label	Direction	Magnitude[lb,lb-ft]
1	R3D_N1_1	X	-21.745
2	R3D_N1_1	Y	220.42
3	R3D_N2_1	X	-11.676
4	R3D_N2_1	Y	219.355
5	R3D_N132_1	Y	258.254
6	R3D_N133_1	X	-1.762
7	R3D_N133_1	Y	323.067
8	R3D_N109_1	Y	258.537
9	R3D_N110A_1	X	1.903



**Point Loads and Moments (Cat 17 : OL2) (Continued)**

	Label	Direction	Magnitude[lb.lb-ft]
6	R3D_N2_1	Z	-74.999
7	R3D_N132_1	X	-4.549
8	R3D_N132_1	Y	-4194.048
9	R3D_N132_1	Z	1851.828
10	R3D_N133_1	X	1.901
11	R3D_N133_1	Y	1461.161
12	R3D_N133_1	Z	-98.875
13	R3D_N109_1	X	4.241
14	R3D_N109_1	Y	-4200.66
15	R3D_N109_1	Z	1854.24
16	R3D_N110A_1	X	-2.264
17	R3D_N110A_1	Y	1463.146
18	R3D_N110A_1	Z	-98.793
19	R3D_N121_1	X	-4.318
20	R3D_N121_1	Y	-4064.994
21	R3D_N121_1	Z	1670.061
22	R3D_N122_1	X	2.673
23	R3D_N122_1	Y	1289.409
24	R3D_N122_1	Z	-97.738
25	R3D_N133B_1	X	4.218
26	R3D_N133B_1	Y	-4064.785
27	R3D_N133B_1	Z	1669.48
28	R3D_N134B_1	X	-2.797
29	R3D_N134B_1	Y	1288.424
30	R3D_N134B_1	Z	-97.725
31	R3D_N155_1	X	-195.322
32	R3D_N155_1	Y	-3004.366
33	R3D_N155_1	Z	1153.961
34	R3D_N156_1	X	-29.612
35	R3D_N156_1	Y	886.833
36	R3D_N156_1	Z	-75.712

**Point Loads and Moments (Cat 18 : OL3)**

	Label	Direction	Magnitude[lb.lb-ft]
1	R3D_N1_1	X	-163.848
2	R3D_N1_1	Y	3027.164
3	R3D_N1_1	Z	-1617.926
4	R3D_N2_1	X	-96.241
5	R3D_N2_1	Y	-155.737
6	R3D_N2_1	Z	106.452
7	R3D_N132_1	X	4.183
8	R3D_N132_1	Y	4394.305
9	R3D_N132_1	Z	-2615.948
10	R3D_N133_1	X	-13.542
11	R3D_N133_1	Y	-416.726
12	R3D_N133_1	Z	139.9
13	R3D_N109_1	X	-3.949
14	R3D_N109_1	Y	4401.498
15	R3D_N109_1	Z	-2619.854
16	R3D_N110A_1	X	14.645
17	R3D_N110A_1	Y	-417.822
18	R3D_N110A_1	Z	139.802
19	R3D_N121_1	X	3.88
20	R3D_N121_1	Y	4204.328
21	R3D_N121_1	Z	-2368.412
22	R3D_N122_1	X	-1.619



**Point Loads and Moments (Cat 18 : OL3) (Continued)**

	Label	Direction	Magnitude[lb,lb-ft]
23	R3D_N122_1	Y	-284.916
24	R3D_N122_1	Z	138.535
25	R3D_N133B_1	X	-3.811
26	R3D_N133B_1	Y	4204.49
27	R3D_N133B_1	Z	-2368.375
28	R3D_N134B_1	X	2.161
29	R3D_N134B_1	Y	-284.103
30	R3D_N134B_1	Z	138.541
31	R3D_N155_1	X	163.548
32	R3D_N155_1	Y	3069.564
33	R3D_N155_1	Z	-1641.408
34	R3D_N156_1	X	94.598
35	R3D_N156_1	Y	-159.654
36	R3D_N156_1	Z	107.471

**Point Loads and Moments (Cat 19 : OL4)**

	Label	Direction	Magnitude[lb,lb-ft]
1	R3D_N1_1	X	-77.472
2	R3D_N1_1	Y	1955.16
3	R3D_N1_1	Z	-1403.198
4	R3D_N2_1	X	-113.615
5	R3D_N2_1	Y	477.896
6	R3D_N2_1	Z	92.197
7	R3D_N132_1	X	2.337
8	R3D_N132_1	Y	2924.607
9	R3D_N132_1	Z	-2258.599
10	R3D_N133_1	X	-17.861
11	R3D_N133_1	Y	576.101
12	R3D_N133_1	Z	120.918
13	R3D_N109_1	X	-2.249
14	R3D_N109_1	Y	2929.598
15	R3D_N109_1	Z	-2262.254
16	R3D_N110A_1	X	19.148
17	R3D_N110A_1	Y	576.125
18	R3D_N110A_1	Z	120.843
19	R3D_N121_1	X	2.09
20	R3D_N121_1	Y	2756.224
21	R3D_N121_1	Z	-2050.123
22	R3D_N122_1	Y	626.949
23	R3D_N122_1	Z	119.876
24	R3D_N133B_1	X	-2.071
25	R3D_N133B_1	Y	2756.624
26	R3D_N133B_1	Z	-2050.537
27	R3D_N134B_1	Y	627.322
28	R3D_N134B_1	Z	119.894
29	R3D_N155_1	X	77.367
30	R3D_N155_1	Y	1982.992
31	R3D_N155_1	Z	-1423.598
32	R3D_N156_1	X	111.654
33	R3D_N156_1	Y	483.178
34	R3D_N156_1	Z	93.084

**Point Loads and Moments (Cat 20 : OL5)**

	Label	Direction	Magnitude[lb,lb-ft]
1	R3D_N1_1	X	-45.503
2	R3D_N1_1	Y	1123.812



---

**Point Loads and Moments (Cat 20 : OL5) (Continued)**

---

	Label	Direction	Magnitude[lb,lb-ft]
3	R3D_N1_1	Z	-610.817
4	R3D_N2_1	X	-30.953
5	R3D_N2_1	Y	-60.735
6	R3D_N2_1	Z	36.061
7	R3D_N132_1	X	3.876
8	R3D_N132_1	Y	613.58
9	R3D_N132_1	Z	-372.601
10	R3D_N133_1	Y	-59.323
11	R3D_N133_1	Z	20.103
12	R3D_N109_1	X	3.78
13	R3D_N109_1	Y	1238.86
14	R3D_N109_1	Z	-735.694
15	R3D_N110A_1	X	12.567
16	R3D_N110A_1	Y	-117.366
17	R3D_N110A_1	Z	37.266
18	R3D_N121_1	X	3.219
19	R3D_N121_1	Y	585.782
20	R3D_N121_1	Z	-330.173
21	R3D_N122_1	X	1.197
22	R3D_N122_1	Y	-37.789
23	R3D_N122_1	Z	23.362
24	R3D_N133B_1	X	1.86
25	R3D_N133B_1	Y	601.464
26	R3D_N133B_1	Z	-338.515
27	R3D_N134B_1	X	2.316
28	R3D_N134B_1	Y	-40.41
29	R3D_N134B_1	Z	20.549
30	R3D_N155_1	X	32.816
31	R3D_N155_1	Y	447.381
32	R3D_N155_1	Z	-233.869
33	R3D_N156_1	X	14.676
34	R3D_N156_1	Y	-19.117
35	R3D_N156_1	Z	15.359

---

**Point Loads and Moments (Cat 21 : OL6)**

---

	Label	Direction	Magnitude[lb,lb-ft]
1	R3D_N1_1	X	43.45
2	R3D_N1_1	Y	-1108.722
3	R3D_N1_1	Z	602.673
4	R3D_N2_1	X	29.167
5	R3D_N2_1	Y	60.023
6	R3D_N2_1	Z	-34.806
7	R3D_N132_1	X	-3.569
8	R3D_N132_1	Y	-614.196
9	R3D_N132_1	Z	372.261
10	R3D_N133_1	Y	59.094
11	R3D_N133_1	Z	-20.056
12	R3D_N109_1	X	-3.552
13	R3D_N109_1	Y	-1087.12
14	R3D_N109_1	Z	649.584
15	R3D_N110A_1	X	-12.012
16	R3D_N110A_1	Y	106.511
17	R3D_N110A_1	Z	-33.915
18	R3D_N121_1	X	-2.737
19	R3D_N121_1	Y	-576.144
20	R3D_N121_1	Z	324.045

---



**Point Loads and Moments (Cat 21 : OL6) (Continued)**

	Label	Direction	Magnitude[lb.-ft]
21	R3D N122 1	Y	35.925
22	R3D N122 1	Z	-22.402
23	R3D N133B 1	X	-1.689
24	R3D N133B 1	Y	-603.401
25	R3D N133B 1	Z	339.72
26	R3D N134B 1	X	-2.24
27	R3D N134B 1	Y	41.184
28	R3D N134B 1	Z	-20.38
29	R3D N155 1	X	-31.947
30	R3D N155 1	Y	-446.33
31	R3D N155 1	Z	233.904
32	R3D N156 1	X	-14.567
33	R3D N156 1	Y	19.299
34	R3D N156 1	Z	-15.348

**Slabs**

	Label	Thickness [in]	Material	Local Axis Angle [deg]	Analysis Offset [in]
1	S1	24	Conc2500NW	0	0
2	S2	24	Conc2500NW	0	0
3	S3	24	Conc2500NW	0	0
4	S4	24	Conc2500NW	0	0
5	S5	24	Conc2500NW	0	0
6	S6	24	Conc2500NW	0	0

**Load Combinations**

Label	Solve	Service A	SF	Cat..Fa...	Cat..Fa...	Cat..Fa...	Cat..Fa...	Cat..Fa...	Cat..Fa...	Cat..Fa...	Cat..Fa...	Cat..Fa...	Cat..Fa...	C...	F...	C...	F...
1	1.0 D	Yes	Yes	1.5	DL	1											
2	1.0 D + 1....	Yes	Yes	1.5	DL	1	RLL	1									
3	1.0 D + 0....	Yes	Yes	1.5	DL	1	RLL		OL1	.6							
4	1.0 D + 0....	Yes	Yes	1.5	DL	1	RLL		OL2	.6							
5	1.0 D + 0....	Yes	Yes	1.5	DL	1	RLL		OL3	.6							
6	1.0 D + 0....	Yes	Yes	1.5	DL	1	RLL		OL4	.6							
7	1.0 D + 0....	Yes	Yes	1.5	DL	1	RLL		OL5	.6							
8	1.0 D + 0....	Yes	Yes	1.5	DL	1	RLL		OL6	.6							
9	1.0 D + 0....	Yes	Yes	1.5	DL	1	RLL	.75	OL1	.45							
10	1.0 D + 0....	Yes	Yes	1.5	DL	1	RLL	.75	OL2	.45							
11	1.0 D + 0....	Yes	Yes	1.5	DL	1	RLL	.75	OL3	.45							
12	1.0 D + 0....	Yes	Yes	1.5	DL	1	RLL	.75	OL4	.45							
13	1.0 D + 0....	Yes	Yes	1.5	DL	1	RLL	.75	OL5	.45							
14	1.0 D + 0....	Yes	Yes	1.5	DL	1	RLL	.75	OL6	.45							
15	0.6 D + 0....	Yes	Yes		DL	.6	RLL		OL1	.6							
16	0.6 D + 0....	Yes	Yes		DL	.6	RLL		OL2	.6							
17	0.6 D + 0....	Yes	Yes		DL	.6	RLL		OL3	.6							
18	0.6 D + 0....	Yes	Yes		DL	.6	RLL		OL4	.6							
19	0.6 D + 0....	Yes	Yes		DL	.6	RLL		OL5	.6							
20	0.6 D + 0....	Yes	Yes		DL	.6	RLL		OL6	.6							
21																	
22	1.4D	Yes			DL	1.4											
23	1.2D+1.6SL	Yes			DL	1.2	RLL	1.6									
24	1.2D+1.6S...	Yes			DL	1.2	RLL	1.6	OL1	.5							
25	1.2D+1.6S...	Yes			DL	1.2	RLL	1.6	OL2	.5							
26	1.2D+1.6S...	Yes			DL	1.2	RLL	1.6	OL3	.5							
27	1.2D+1.6S...	Yes			DL	1.2	RLL	1.6	OL4	.5							
28	1.2D+1.6S...	Yes			DL	1.2	RLL	1.6	OL5	.5							
29	1.2D+1.6S...	Yes			DL	1.2	RLL	1.6	OL6	.5							
30	1.2D+1.0...	Yes			DL	1.2			OL1	1							



**Load Combinations (Continued)**

Label	Solve	Service	A..SF	Cat..Fa...	Cat..Fa...	Cat..Fa...	Cat..Fa...	Cat..Fa...	Cat..Fa...	Cat..Fa...	Cat..Fa...	Cat..Fa...	C...	F...	C...	F...
31	1.2D-1.0Wx	Yes		DL	1.2			OL2	1							
32	1.2D+1.0...	Yes		DL	1.2			OL3	1							
33	1.2D-1.0Wz	Yes		DL	1.2			OL4	1							
34	1.2D+1.0...	Yes		DL	1.2			OL5	1							
35	1.2D-1.0...	Yes		DL	1.2			OL6	1							
36	.9D+1.0Wx	Yes		DL	.9			OL1	1							
37	.9D-1.0Wx	Yes		DL	.9			OL2	1							
38	.9D+1.0Wz	Yes		DL	.9			OL3	1							
39	.9D-1.0Wz	Yes		DL	.9			OL4	1							
40	.9D+1.0W...	Yes		DL	.9			OL5	1							
41	.9D-1.0W90	Yes		DL	.9			OL6	1							

**Design Strips**

Label	Rebar Angle from Pl...	No. of Design Cuts	Design Rule	
1	DS1	0	50	Typical
2	DS2	90	50	Typical

**Load Categories**

Category	Point Loads	Line Loads	Area Loads
1	DL	18	
2	OL1	36	
3	OL2	36	
4	OL3	36	
5	OL4	34	
6	OL5	35	
7	OL6	34	

**Strip Reinforcing**

Label	UC Top	LC	Top Bars	Governing ...	UC Bot	LC	Bot B...	Gover...	UC Shear	LC	Governing ...
1	DS1	.019	32	#5@10in	DS1-X25	.049	37	#5@1...DS1-...	.052	37	DS1-X45
2	DS2	.003	36	#5@10in	DS2-X26	.004	32	#5@1...DS2-...	.006	32	DS2-X50

**Slab Overturning Safety Factors**

LC	Slab	Angle[deg]	Mo-xx[lb-ft]	Ms-xx[lb-ft]	Mo-zz[lb-ft]	Ms-zz[lb-ft]	Ms-xx/Mo-xx	Ms-zz/Mo-zz
1	1	S1	0	0	36600.577	0	9452.513	9.999+
2	1	S2	0	0	37516.562	0	9559.633	9.999+
3	1	S3	0	0	37375.075	0	9550.709	9.999+
4	1	S4	0	0	37375.5	0	9550.845	9.999+
5	1	S5	0	0	37512.952	0	9566.127	9.999+
6	1	S6	0	0	36629.453	0	9325.368	9.999+
7	2	S1	0	0	36600.577	0	9452.513	9.999+
8	2	S2	0	0	37516.562	0	9559.633	9.999+
9	2	S3	0	0	37375.075	0	9550.709	9.999+
10	2	S4	0	0	37375.5	0	9550.845	9.999+
11	2	S5	0	0	37512.952	0	9566.127	9.999+
12	2	S6	0	0	36629.453	0	9325.368	9.999+
13	3	S1	0	14285.584	36607.778	2114.504	9452.513	2.563
14	3	S2	0	20914.118	37078.394	2573.236	9567.246	1.773
15	3	S3	0	19922.258	37120.585	2523.221	9550.709	1.863
16	3	S4	0	19923.53	37121.218	2523.22	9550.845	1.863
17	3	S5	0	20880.308	37075.479	2567.938	9566.127	1.776
18	3	S6	0	14485.669	36625.579	2137.257	9457.942	2.528
19	4	S1	0	15157.987	36607.778	1838.602	9452.513	2.415
20	4	S2	0	21583.006	37078.394	2055.508	9559.633	1.718
21	4	S3	0	20848.074	37120.585	2083.663	9550.709	1.781





Company : Vector Structural Engineering  
 Designer : STB  
 Job Number : U2716.099.191  
 Model Name : Ground Mount

July 29, 2019  
 5:09 PM  
 Checked By: JSP

**Slab Overturning Safety Factors (Continued)**

	LC	Slab	Angle[deg]	Mo-xx[lb-ft]	Ms-xx[lb-ft]	Mo-zz[lb-ft]	Ms-zz[lb-ft]	Ms-xx/Mo-xx	Ms-zz/Mo-zz
22	4	S4	0	20847.244	37121.218	2083.976	9550.845	1.781	4.583
23	4	S5	0	21549.068	37075.479	2052.843	9559.079	1.721	4.657
24	4	S6	0	15367.39	36625.579	1858.07	9457.942	2.383	5.09
25	5	S1	0	0	36740.349	0	11918.19	9.999+	9.999+
26	5	S2	0	1082.943	37516.562	0	12534.554	9.999+	9.999+
27	5	S3	0	302.303	37375.075	0	12487.555	9.999+	9.999+
28	5	S4	0	298.083	37375.5	0	12493.116	9.999+	9.999+
29	5	S5	0	1079.186	37512.952	0	12560.542	9.999+	9.999+
30	5	S6	0	0	36761.041	0	11198.026	9.999+	9.999+
31	6	S1	0	0	39152.601	0	11506.61	9.999+	9.999+
32	6	S2	0	0	40435.315	0	12168.646	9.999+	9.999+
33	6	S3	0	0	40642.77	0	12085.582	9.999+	9.999+
34	6	S4	0	0	40644.925	0	12091.29	9.999+	9.999+
35	6	S5	0	0	40431.571	0	12210.286	9.999+	9.999+
36	6	S6	0	0	39209.252	0	10948.171	9.999+	9.999+
37	7	S1	0	0	36621.658	0	10341.568	9.999+	9.999+
38	7	S2	0	304.105	37516.562	0	10381.138	9.999+	9.999+
39	7	S3	0	28.025	37375.075	0	9956.405	9.999+	9.999+
40	7	S4	0	40.273	37375.5	0	9966.624	9.999+	9.999+
41	7	S5	0	164.426	37512.952	0	9977.169	9.999+	9.999+
42	7	S6	0	0	36675.254	0	9589.575	9.999+	9.999+
43	8	S1	0	6115.608	36607.778	873.666	9452.513	5.986	9.999+
44	8	S2	0	6024.197	37078.394	754.133	9567.246	6.155	9.999+
45	8	S3	0	3181.557	37120.585	408.448	9550.709	9.999+	9.999+
46	8	S4	0	3332.987	37121.218	426.378	9550.845	9.999+	9.999+
47	8	S5	0	3409.739	37075.479	420.609	9559.079	9.999+	9.999+
48	8	S6	0	2454.236	36625.579	376.089	9457.942	9.999+	9.999+
49	9	S1	0	10714.188	36607.778	1585.878	9452.513	3.417	5.96
50	9	S2	0	15685.589	37078.394	1929.927	9567.246	2.364	4.957
51	9	S3	0	14941.693	37120.585	1892.416	9550.709	2.484	5.047
52	9	S4	0	14942.648	37121.218	1892.415	9550.845	2.484	5.047
53	9	S5	0	15660.231	37075.479	1925.953	9566.127	2.367	4.967
54	9	S6	0	10864.252	36625.579	1602.942	9457.942	3.371	5.9
55	10	S1	0	11368.49	36607.778	1378.952	9452.513	3.22	6.855
56	10	S2	0	16187.255	37078.394	1541.631	9559.633	2.291	6.201
57	10	S3	0	15636.056	37120.585	1562.747	9550.709	2.374	6.111
58	10	S4	0	15635.433	37121.218	1562.982	9550.845	2.374	6.111
59	10	S5	0	16161.801	37075.479	1539.633	9559.079	2.294	6.209
60	10	S6	0	11525.543	36625.579	1393.553	9457.942	3.178	6.787
61	11	S1	0	0	36705.406	0	11301.771	9.999+	9.999+
62	11	S2	0	812.207	37516.562	0	11790.824	9.999+	9.999+
63	11	S3	0	226.727	37375.075	0	11753.344	9.999+	9.999+
64	11	S4	0	223.562	37375.5	0	11757.548	9.999+	9.999+
65	11	S5	0	809.389	37512.952	0	11811.938	9.999+	9.999+
66	11	S6	0	0	36728.144	0	10729.861	9.999+	9.999+
67	12	S1	0	0	38514.595	0	10993.086	9.999+	9.999+
68	12	S2	0	0	39705.626	0	11516.393	9.999+	9.999+
69	12	S3	0	0	39825.847	0	11451.864	9.999+	9.999+
70	12	S4	0	0	39827.569	0	11456.179	9.999+	9.999+
71	12	S5	0	0	39701.916	0	11549.246	9.999+	9.999+
72	12	S6	0	0	38564.302	0	10542.47	9.999+	9.999+
73	13	S1	0	0	36616.388	0	10119.304	9.999+	9.999+
74	13	S2	0	228.078	37516.562	0	10175.761	9.999+	9.999+
75	13	S3	0	21.018	37375.075	0	9854.981	9.999+	9.999+
76	13	S4	0	30.205	37375.5	0	9862.679	9.999+	9.999+
77	13	S5	0	123.319	37512.952	0	9874.408	9.999+	9.999+
78	13	S6	0	0	36663.803	0	9523.523	9.999+	9.999+



Company : Vector Structural Engineering  
 Designer : STB  
 Job Number : U2716.099.191  
 Model Name : Ground Mount

July 29, 2019  
 5:09 PM  
 Checked By: JSP

**Slab Overturning Safety Factors (Continued)**

LC	Slab	Angle[deg]	Mo-xx[lb-ft]	Ms-xx[lb-ft]	Mo-zz[lb-ft]	Ms-zz[lb-ft]	Ms-xx/Mo-xx	Ms-zz/Mo-zz	
79	14	S1	0	4586.706	36607.778	655.249	9452.513	7.981	9.999+
80	14	S2	0	4518.148	37078.394	565.6	9567.246	8.207	9.999+
81	14	S3	0	2386.168	37120.585	306.336	9550.709	9.999+	9.999+
82	14	S4	0	2499.74	37121.218	319.783	9550.845	9.999+	9.999+
83	14	S5	0	2557.305	37075.479	315.457	9559.079	9.999+	9.999+
84	14	S6	0	1840.677	36625.579	282.067	9457.942	9.999+	9.999+
85	15	S1	0	14285.584	21964.667	2114.504	5671.508	1.538	2.682
86	15	S2	0	20914.118	22247.036	2573.236	5740.348	1.064	2.231
87	15	S3	0	19922.258	22272.351	2523.221	5730.426	1.118	2.271
88	15	S4	0	19923.53	22272.731	2523.22	5730.507	1.118	2.271
89	15	S5	0	20880.308	22245.287	2567.938	5739.676	1.065	2.235
90	15	S6	0	14485.669	21975.347	2137.257	5674.765	1.517	2.655
91	16	S1	0	15157.987	21964.667	1838.602	5671.508	1.449	3.085
92	16	S2	0	21583.006	22247.036	2055.508	5735.78	1.031	2.79
93	16	S3	0	20848.074	22272.351	2083.663	5730.426	1.068	2.75
94	16	S4	0	20847.244	22272.731	2083.976	5730.507	1.068	2.75
95	16	S5	0	21549.068	22245.287	2052.843	5735.448	1.032	2.794
96	16	S6	0	15367.39	21975.347	1858.07	5674.765	1.43	3.054
97	17	S1	0	0	22100.118	0	8137.184	9.999+	9.999+
98	17	S2	0	1082.943	22509.937	0	8710.701	9.999+	9.999+
99	17	S3	0	302.303	22425.045	0	8667.271	9.999+	9.999+
100	17	S4	0	298.083	22425.3	0	8672.778	9.999+	9.999+
101	17	S5	0	1079.186	22507.771	0	8734.091	9.999+	9.999+
102	17	S6	0	0	22109.259	0	7467.879	9.999+	9.999+
103	18	S1	0	0	24512.37	0	7725.605	9.999+	9.999+
104	18	S2	0	0	25428.69	0	8344.793	9.999+	9.999+
105	18	S3	0	0	25692.74	0	8265.298	9.999+	9.999+
106	18	S4	0	0	25694.725	0	8270.952	9.999+	9.999+
107	18	S5	0	0	25426.39	0	8383.835	9.999+	9.999+
108	18	S6	0	0	24557.471	0	7218.023	9.999+	9.999+
109	19	S1	0	0	21981.427	0	6560.563	9.999+	9.999+
110	19	S2	0	304.105	22509.937	0	6557.285	9.999+	9.999+
111	19	S3	0	28.025	22425.045	0	6136.122	9.999+	9.999+
112	19	S4	0	40.273	22425.3	0	6146.286	9.999+	9.999+
113	19	S5	0	164.426	22507.771	0	6150.718	9.999+	9.999+
114	19	S6	0	0	22023.473	0	5859.428	9.999+	9.999+
115	20	S1	0	6115.608	21964.667	873.666	5671.508	3.592	6.492
116	20	S2	0	6024.197	22247.036	754.133	5740.348	3.693	7.612
117	20	S3	0	3181.557	22272.351	408.448	5730.426	7	9.999+
118	20	S4	0	3332.987	22272.731	426.378	5730.507	6.683	9.999+
119	20	S5	0	3409.739	22245.287	420.609	5735.448	6.524	9.999+
120	20	S6	0	2454.236	21975.347	376.089	5674.765	8.954	9.999+

**Slab Sliding Safety Factors**

LC	Slab	Angle[deg]	Va-xx[lb]	Vr-xx[lb]	Va-zz[lb]	Vr-zz[lb]	SR-xx	SR-zz	
1	1	S1	0	33.421	2252.561	0	2252.561	9.999+	9.999+
2	1	S2	0	1.903	2295.225	0	2295.225	9.999+	9.999+
3	1	S3	0	0	2292.17	0	2292.17	9.999+	9.999+
4	1	S4	0	0	2292.203	0	2292.203	9.999+	9.999+
5	1	S5	0	1.762	2295.025	0	2295.025	9.999+	9.999+
6	1	S6	0	33.143	2253.997	0	2253.997	9.999+	9.999+
7	2	S1	0	33.421	2252.561	0	2252.561	9.999+	9.999+
8	2	S2	0	1.903	2295.225	0	2295.225	9.999+	9.999+
9	2	S3	0	0	2292.17	0	2292.17	9.999+	9.999+
10	2	S4	0	0	2292.203	0	2292.203	9.999+	9.999+
11	2	S5	0	1.762	2295.025	0	2295.025	9.999+	9.999+



Company : Vector Structural Engineering  
 Designer : STB  
 Job Number : U2716.099.191  
 Model Name : Ground Mount

July 29, 2019  
 5:09 PM  
 Checked By: JSP

**Slab Sliding Safety Factors (Continued)**

	LC	Slab	Angle[deg]	Va-xx[lb]	Vr-xx[lb]	Va-zz[lb]	Vr-zz[lb]	SR-xx	SR-zz
12	2	S6	0	33.143	2253.997	0	2253.997	9.999+	9.999+
13	3	S1	0	100.406	1809.317	777.722	1809.317	9.999+	2.326
14	3	S2	0	3.601	1680.291	1276.1	1680.291	9.999+	1.317
15	3	S3	0	1.163	1687.156	1147.373	1687.156	9.999+	1.47
16	3	S4	0	.849	1687.038	1147.351	1687.038	9.999+	1.47
17	3	S5	0	3.054	1681.031	1274.039	1681.031	9.999+	1.319
18	3	S6	0	99.684	1804.813	789.281	1804.813	9.999+	2.287
19	4	S1	0	102.073	1876.334	637.497	1876.334	9.999+	2.943
20	4	S2	0	3.09	1802.473	1053.268	1802.473	9.999+	1.711
21	4	S3	0	.987	1792.565	943.394	1792.565	9.999+	1.9
22	4	S4	0	.853	1792.458	943.053	1792.458	9.999+	1.901
23	4	S5	0	3.351	1803.105	1051.772	1803.105	9.999+	1.714
24	4	S6	0	101.817	1872.841	646.95	1872.841	9.999+	2.895
25	5	S1	0	189.475	2769.418	906.885	2769.418	9.999+	3.054
26	5	S2	0	8.321	3012.287	1488.031	3012.287	9.999+	2.024
27	5	S3	0	1.357	2997.664	1337.926	2997.664	9.999+	2.241
28	5	S4	0	.99	2997.872	1337.901	2997.872	9.999+	2.241
29	5	S5	0	7.377	3010.989	1485.629	3010.989	9.999+	2.027
30	5	S6	0	188.031	2777.781	920.362	2777.781	9.999+	3.018
31	6	S1	0	148.074	2690.511	786.6	2690.511	9.999+	3.42
32	6	S2	0	12.043	2926.256	1284.847	2926.256	9.999+	2.278
33	6	S3	0	1.254	2901.141	1158.148	2901.141	9.999+	2.505
34	6	S4	0	1.243	2901.313	1158.386	2901.313	9.999+	2.505
35	6	S5	0	11.076	2925.152	1282.609	2925.152	9.999+	2.281
36	6	S6	0	146.556	2697.908	798.308	2697.908	9.999+	3.38
37	7	S1	0	79.295	2443.915	344.854	2443.915	9.999+	7.087
38	7	S2	0	11.711	2497.094	419.057	2497.094	9.999+	5.959
39	7	S3	0	2.65	2390.809	184.087	2390.809	9.999+	9.999+
40	7	S4	0	2.506	2393.193	190.779	2393.193	9.999+	9.999+
41	7	S5	0	.563	2394.791	211.499	2394.791	9.999+	9.999+
42	7	S6	0	61.639	2331.085	131.106	2331.085	9.999+	9.999+
43	8	S1	0	10.149	2063.795	340.721	2063.795	9.999+	6.057
44	8	S2	0	7.435	2118.716	369.401	2118.716	9.999+	5.736
45	8	S3	0	1.642	2194.931	180.986	2194.931	9.999+	9.999+
46	8	S4	0	2.357	2191.004	191.604	2191.004	9.999+	9.999+
47	8	S5	0	3.903	2195.106	211.323	2195.106	9.999+	9.999+
48	8	S6	0	5.235	2177.132	131.134	2177.132	9.999+	9.999+
49	9	S1	0	66.949	1920.128	583.292	1920.128	9.999+	3.292
50	9	S2	0	2.225	1834.024	957.075	1834.024	9.999+	1.916
51	9	S3	0	.873	1838.409	860.53	1838.409	9.999+	2.136
52	9	S4	0	.637	1838.329	860.514	1838.329	9.999+	2.136
53	9	S5	0	1.85	1834.53	955.53	1834.53	9.999+	1.92
54	9	S6	0	66.477	1917.109	591.96	1917.109	9.999+	3.239
55	10	S1	0	68.2	1970.391	478.123	1970.391	9.999+	4.121
56	10	S2	0	2.793	1925.661	789.951	1925.661	9.999+	2.438
57	10	S3	0	.74	1917.466	707.545	1917.466	9.999+	2.71
58	10	S4	0	.64	1917.394	707.29	1917.394	9.999+	2.711
59	10	S5	0	2.954	1926.085	788.829	1926.085	9.999+	2.442
60	10	S6	0	68.077	1968.13	485.212	1968.13	9.999+	4.056
61	11	S1	0	150.461	2640.203	680.163	2640.203	9.999+	3.882
62	11	S2	0	6.717	2833.022	1116.024	2833.022	9.999+	2.538
63	11	S3	0	1.017	2821.291	1003.445	2821.291	9.999+	2.812
64	11	S4	0	.743	2821.455	1003.426	2821.455	9.999+	2.812
65	11	S5	0	5.974	2831.998	1114.222	2831.998	9.999+	2.542
66	11	S6	0	149.309	2646.835	690.272	2646.835	9.999+	3.834
67	12	S1	0	119.411	2581.024	589.95	2581.024	9.999+	4.375
68	12	S2	0	9.508	2768.498	963.635	2768.498	9.999+	2.873



Company : Vector Structural Engineering  
 Designer : STB  
 Job Number : U2716.099.191  
 Model Name : Ground Mount

July 29, 2019  
 5:09 PM  
 Checked By: JSP

**Slab Sliding Safety Factors (Continued)**

	LC	Slab	Angle[deg]	Va-xx[lb]	Vr-xx[lb]	Va-zz[lb]	Vr-zz[lb]	SR-xx	SR-zz
69	12	S3	0	.94	2748.899	868.611	2748.899	9.999+	3.165
70	12	S4	0	.932	2749.035	868.789	2749.035	9.999+	3.164
71	12	S5	0	8.748	2767.62	961.957	2767.62	9.999+	2.877
72	12	S6	0	118.203	2586.93	598.731	2586.93	9.999+	4.321
73	13	S1	0	67.827	2396.076	258.64	2396.076	9.999+	9.264
74	13	S2	0	9.259	2446.627	314.293	2446.627	9.999+	7.785
75	13	S3	0	1.987	2366.149	138.065	2366.149	9.999+	9.999+
76	13	S4	0	1.879	2367.945	143.084	2367.945	9.999+	9.999+
77	13	S5	0	.018	2369.849	158.624	2369.849	9.999+	9.999+
78	13	S6	0	54.515	2311.813	98.33	2311.813	9.999+	9.999+
79	14	S1	0	.743	2110.987	255.54	2110.987	9.999+	8.261
80	14	S2	0	5.1	2162.843	277.051	2162.843	9.999+	7.807
81	14	S3	0	1.232	2219.241	135.739	2219.241	9.999+	9.999+
82	14	S4	0	1.768	2216.303	143.703	2216.303	9.999+	9.999+
83	14	S5	0	3.368	2220.086	158.493	2220.086	9.999+	9.999+
84	14	S6	0	12.212	2196.348	98.35	2196.348	9.999+	9.999+
85	15	S1	0	113.775	908.293	777.722	908.293	7.983	1.168
86	15	S2	0	4.362	762.201	1276.1	762.201	9.999+	.597
87	15	S3	0	1.163	770.287	1147.373	770.287	9.999+	.671
88	15	S4	0	.849	770.156	1147.351	770.156	9.999+	.671
89	15	S5	0	3.759	763.021	1274.039	763.021	9.999+	.599
90	15	S6	0	112.942	903.214	789.281	903.214	7.997	1.144
91	16	S1	0	115.442	975.31	637.497	975.31	8.448	1.53
92	16	S2	0	2.328	884.383	1053.268	884.383	9.999+	.84
93	16	S3	0	.987	875.697	943.394	875.697	9.999+	.928
94	16	S4	0	.853	875.577	943.053	875.577	9.999+	.928
95	16	S5	0	2.646	885.095	1051.772	885.095	9.999+	.842
96	16	S6	0	115.074	971.242	646.95	971.242	8.44	1.501
97	17	S1	0	176.106	1868.393	906.885	1868.393	9.999+	2.06
98	17	S2	0	7.56	2094.197	1488.031	2094.197	9.999+	1.407
99	17	S3	0	1.357	2080.796	1337.926	2080.796	9.999+	1.555
100	17	S4	0	.99	2080.991	1337.901	2080.991	9.999+	1.555
101	17	S5	0	6.673	2092.979	1485.629	2092.979	9.999+	1.409
102	17	S6	0	174.773	1876.182	920.362	1876.182	9.999+	2.039
103	18	S1	0	134.705	1789.487	786.6	1789.487	9.999+	2.275
104	18	S2	0	11.281	2008.165	1284.847	2008.165	9.999+	1.563
105	18	S3	0	1.254	1984.273	1158.148	1984.273	9.999+	1.713
106	18	S4	0	1.243	1984.432	1158.386	1984.432	9.999+	1.713
107	18	S5	0	10.371	2007.142	1282.609	2007.142	9.999+	1.565
108	18	S6	0	133.298	1796.309	798.308	1796.309	9.999+	2.25
109	19	S1	0	65.926	1542.89	344.854	1542.89	9.999+	4.474
110	19	S2	0	10.95	1579.004	419.057	1579.004	9.999+	3.768
111	19	S3	0	2.65	1473.941	184.087	1473.941	9.999+	8.007
112	19	S4	0	2.506	1476.311	190.779	1476.311	9.999+	7.738
113	19	S5	0	1.268	1476.781	211.499	1476.781	9.999+	6.982
114	19	S6	0	48.382	1429.486	131.106	1429.486	9.999+	9.999+
115	20	S1	0	23.518	1162.771	340.721	1162.771	9.999+	3.413
116	20	S2	0	8.196	1200.626	369.401	1200.626	9.999+	3.25
117	20	S3	0	1.642	1278.063	180.986	1278.063	9.999+	7.062
118	20	S4	0	2.357	1274.122	191.604	1274.122	9.999+	6.65
119	20	S5	0	3.199	1277.097	211.323	1277.097	9.999+	6.043
120	20	S6	0	8.022	1275.533	131.134	1275.533	9.999+	9.727



Company : Vector Structural Engineering  
Designer : STB  
Job Number : U2716.099.191  
Model Name : Ground Mount

July 29, 2019  
5:09 PM  
Checked By: JSP

---

### ***Envelope Slab Soil Pressures***

---

	Label	UC	LC	Soil Pressure[psf]	Allowable Bearing[psf]	Point
1	S1	.359	5	538.928	1500	N170
2	S2	.51	16	764.288	1500	N18
3	S3	.431	16	646.55	1500	N22
4	S4	.431	16	646.27	1500	N23
5	S5	.506	16	759.668	1500	N27
6	S6	.362	5	542.263	1500	N205



Company:		Date:	5/14/2018
Engineer:		Page:	1/6
Project:			
Address:			
Phone:			
E-mail:			

### 1. Project information

Customer company:  
Customer contact name:  
Customer e-mail:  
Comment:

Project description:  
Location:  
Fastening description:

### 2. Input Data & Anchor Parameters

#### General

Design method: ACI 318-14  
Units: Imperial units

#### Anchor Information:

Anchor type: Bonded anchor  
Material: F1554 Grade 36  
Diameter (inch): 0.375  
Effective Embedment depth,  $h_{ef}$  (inch): 4.000  
Code report: ICC-ES ESR-4057  
Anchor category: -  
Anchor ductility: Yes  
 $h_{min}$  (inch): 5.25  
 $c_{ac}$  (inch): 7.12  
 $c_{min}$  (inch): 1.75  
 $s_{min}$  (inch): 3.00

#### Base Material

Concrete: Normal-weight  
Concrete thickness,  $h$  (inch): 24.00  
State: Cracked  
Compressive strength,  $f'_c$  (psi): 2500  
 $\Psi_{c,v}$ : 1.0  
Reinforcement condition: B tension, B shear  
Supplemental reinforcement: Not applicable  
Reinforcement provided at corners: No  
Ignore concrete breakout in tension: No  
Ignore concrete breakout in shear: No  
Hole condition: Dry concrete  
Inspection: Periodic  
Temperature range, Short/Long: 150/110°F  
Ignore 6do requirement: Not applicable  
Build-up grout pad: No

#### Base Plate

Length x Width x Thickness (inch): 4.75 x 4.75 x 0.31

#### Recommended Anchor

Anchor Name: SET-3G - SET-3G w/ 3/8"Ø F1554 Gr. 36  
Code Report: ICC-ES ESR-4057





Company:		Date:	5/14/2018
Engineer:		Page:	2/6
Project:			
Address:			
Phone:			
E-mail:			

**Load and Geometry**

Load factor source: ACI 318 Section 5.3

Load combination: not set

Seismic design: No

Anchors subjected to sustained tension: No

Apply entire shear load at front row: No

Anchors only resisting wind and/or seismic loads: No

Strength level loads:

$N_{ua}$  [lb]: 3940

$V_{uax}$  [lb]: 570

$V_{uay}$  [lb]: -2640

$M_{ux}$  [ft-lb]: 0

$M_{uy}$  [ft-lb]: 0

$M_{uz}$  [ft-lb]: 0

<Figure 1>

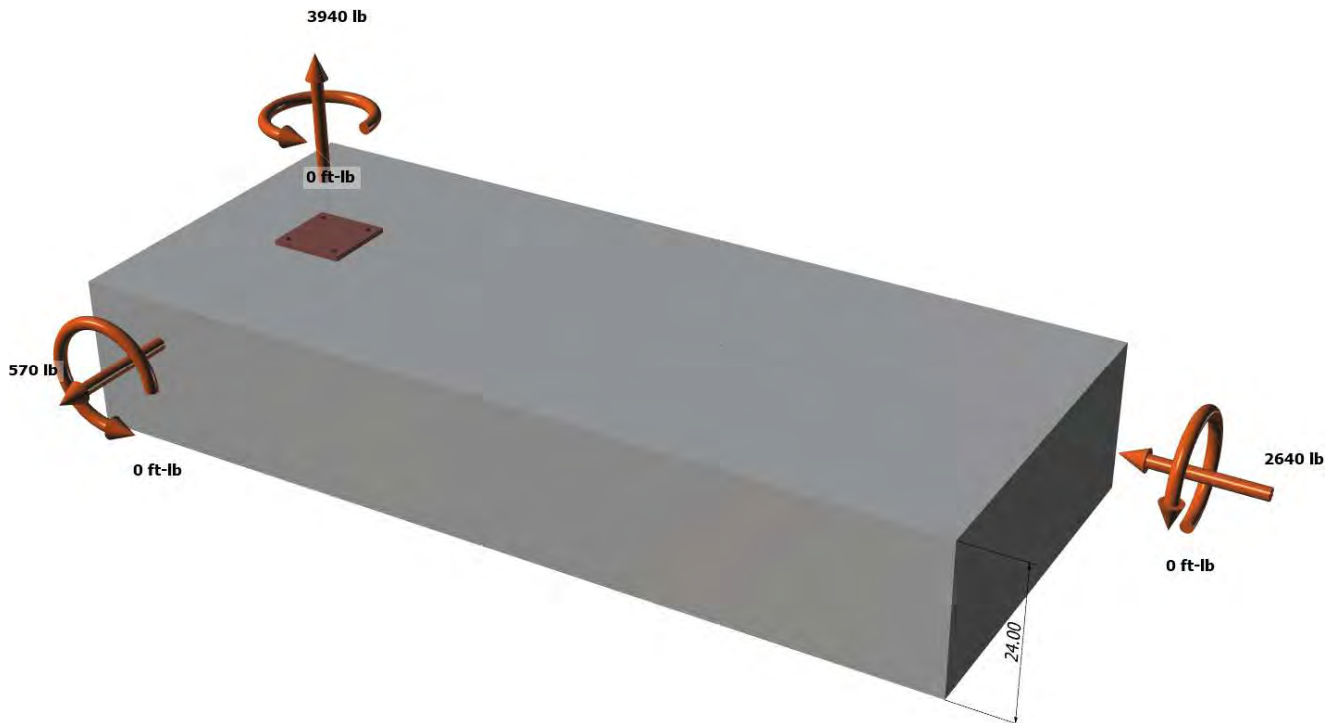



Company:		Date:	5/14/2018
Engineer:		Page:	3/6
Project:			
Address:			
Phone:			
E-mail:			

<Figure 2>

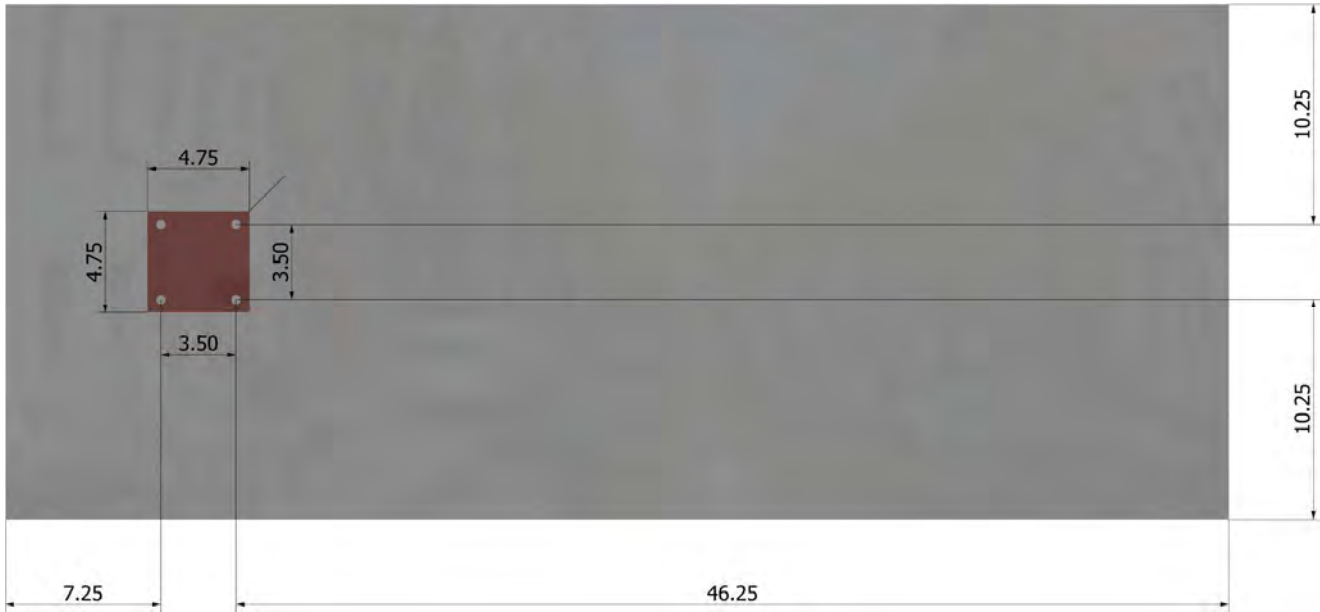





Company:		Date:	5/14/2018
Engineer:		Page:	4/6
Project:			
Address:			
Phone:			
E-mail:			

### 3. Resulting Anchor Forces

Anchor	Tension load, N <sub>ua</sub> (lb)	Shear load x, V <sub>uax</sub> (lb)	Shear load y, V <sub>uay</sub> (lb)	Shear load combined, $\sqrt{(V_{uax})^2 + (V_{uay})^2}$ (lb)
1	985.0	142.5	-660.0	675.2
2	985.0	142.5	-660.0	675.2
3	985.0	142.5	-660.0	675.2
4	985.0	142.5	-660.0	675.2
Sum	3940.0	570.0	-2640.0	2700.8

Maximum concrete compression strain (%): 0.00  
 Maximum concrete compression stress (psi): 0  
 Resultant tension force (lb): 3940  
 Resultant compression force (lb): 0  
 Eccentricity of resultant tension forces in x-axis, e'<sub>Nx</sub> (inch): 0.00  
 Eccentricity of resultant tension forces in y-axis, e'<sub>Ny</sub> (inch): 0.00  
 Eccentricity of resultant shear forces in x-axis, e'<sub>Vx</sub> (inch): 0.00  
 Eccentricity of resultant shear forces in y-axis, e'<sub>Vy</sub> (inch): 0.00

<Figure 3>

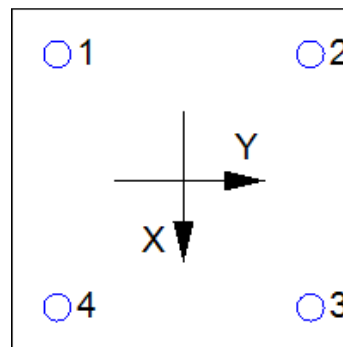

### 4. Steel Strength of Anchor in Tension (Sec. 17.4.1)

N <sub>sa</sub> (lb)	φ	φN <sub>sa</sub> (lb)
4525	0.75	3394

### 5. Concrete Breakout Strength of Anchor in Tension (Sec. 17.4.2)

$$N_b = K_c \lambda_a \sqrt{f_c} c_{hef}^{1.5} \text{ (Eq. 17.4.2.2a)}$$

K <sub>c</sub>	λ <sub>a</sub>	f <sub>c</sub> (psi)	h <sub>ef</sub> (in)	N <sub>b</sub> (lb)
17.0	1.00	2500	4.000	6800

$$\phi N_{cbg} = \phi (A_{Nc} / A_{Nco}) \psi_{ec,N} \psi_{ed,N} \psi_{c,N} \psi_{cp,N} N_b \text{ (Sec. 17.3.1 \& Eq. 17.4.2.1b)}$$

A <sub>Nc</sub> (in <sup>2</sup> )	A <sub>Nco</sub> (in <sup>2</sup> )	c <sub>a,min</sub> (in)	ψ <sub>ec,N</sub>	ψ <sub>ed,N</sub>	ψ <sub>c,N</sub>	ψ <sub>cp,N</sub>	N <sub>b</sub> (lb)	φ	φN <sub>cbg</sub> (lb)
240.25	144.00	7.25	1.000	1.000	1.00	1.000	6800	0.65	7374

### 6. Adhesive Strength of Anchor in Tension (Sec. 17.4.5)

$$\tau_{k,cr} = \tau_{k,cr,short-term} K_{sat} (f_c / 2,500)^n$$

τ <sub>k,cr</sub> (psi)	f <sub>short-term</sub>	K <sub>sat</sub>	f <sub>c</sub> (psi)	n	τ <sub>k,cr</sub> (psi)
1346	1.00	1.00	2500	0.24	1346

$$N_{ba} = \lambda_a \tau_{cr} \pi d_a h_{ef} \text{ (Eq. 17.4.5.2)}$$

λ <sub>a</sub>	τ <sub>cr</sub> (psi)	d <sub>a</sub> (in)	h <sub>ef</sub> (in)	N <sub>ba</sub> (lb)
1.00	1346	0.38	4.000	6343

$$\phi N_{ag} = \phi (A_{Na} / A_{Na0}) \psi_{ec,Na} \psi_{ed,Na} \psi_{cp,Na} N_{ba} \text{ (Sec. 17.3.1 \& Eq. 17.4.5.1b)}$$

A <sub>Na</sub> (in <sup>2</sup> )	A <sub>Na0</sub> (in <sup>2</sup> )	c <sub>Na</sub> (in)	c <sub>a,min</sub> (in)	ψ <sub>ec,Na</sub>	ψ <sub>ed,Na</sub>	ψ <sub>cp,Na</sub>	N <sub>ba</sub> (lb)	φ	φN <sub>ag</sub> (lb)
198.45	112.09	5.29	7.25	1.000	1.000	1.000	6343	0.55	6176



Company:		Date:	5/14/2018
Engineer:		Page:	5/6
Project:			
Address:			
Phone:			
E-mail:			

**8. Steel Strength of Anchor in Shear (Sec. 17.5.1)**

$V_{sa}$ (lb)	$\phi_{grout}$	$\phi$	$\phi_{grout}\phi V_{sa}$ (lb)
2715	1.0	0.65	1765

**9. Concrete Breakout Strength of Anchor in Shear (Sec. 17.5.2)**

**Shear perpendicular to edge in x-direction:**

$V_{bx} = \min|7(l_e / d_a)^{0.2} \sqrt{d_a} \lambda_a \sqrt{f_c} c_{a1}^{1.5}; 9 \lambda_a \sqrt{f_c} c_{a1}^{1.5}|$  (Eq. 17.5.2.2a & Eq. 17.5.2.2b)

$l_e$ (in)	$d_a$ (in)	$\lambda_a$	$f_c$ (psi)	$c_{a1}$ (in)	$V_{bx}$ (lb)
3.00	0.375	1.00	2500	13.75	16564

$\phi V_{cbgx} = \phi (A_{Vc} / A_{Vco}) \psi_{ec,v} \psi_{ed,v} \psi_{c,v} \psi_{h,v} V_{bx}$  (Sec. 17.3.1 & Eq. 17.5.2.1b)

$A_{Vc}$ (in <sup>2</sup> )	$A_{Vco}$ (in <sup>2</sup> )	$\psi_{ec,v}$	$\psi_{ed,v}$	$\psi_{c,v}$	$\psi_{h,v}$	$V_{bx}$ (lb)	$\phi$	$\phi V_{cbgx}$ (lb)
647.11	850.78	1.000	0.805	1.000	1.000	16564	0.70	7103

**Shear perpendicular to edge in y-direction:**

$V_{by} = \min|7(l_e / d_a)^{0.2} \sqrt{d_a} \lambda_a \sqrt{f_c} c_{a1}^{1.5}; 9 \lambda_a \sqrt{f_c} c_{a1}^{1.5}|$  (Eq. 17.5.2.2a & Eq. 17.5.2.2b)

$l_e$ (in)	$d_a$ (in)	$\lambda_a$	$f_c$ (psi)	$c_{a1}$ (in)	$V_{by}$ (lb)
3.00	0.375	1.00	2500	10.75	11450

$\phi V_{cbgy} = \phi (A_{Vc} / A_{Vco}) \psi_{ec,v} \psi_{ed,v} \psi_{c,v} \psi_{h,v} V_{by}$  (Sec. 17.3.1 & Eq. 17.5.2.1b)

$A_{Vc}$ (in <sup>2</sup> )	$A_{Vco}$ (in <sup>2</sup> )	$\psi_{ec,v}$	$\psi_{ed,v}$	$\psi_{c,v}$	$\psi_{h,v}$	$V_{by}$ (lb)	$\phi$	$\phi V_{cbgy}$ (lb)
387.00	520.03	1.000	0.891	1.000	1.000	11450	0.70	5313

**Shear parallel to edge in x-direction:**

$V_{by} = \min|7(l_e / d_a)^{0.2} \sqrt{d_a} \lambda_a \sqrt{f_c} c_{a1}^{1.5}; 9 \lambda_a \sqrt{f_c} c_{a1}^{1.5}|$  (Eq. 17.5.2.2a & Eq. 17.5.2.2b)

$l_e$ (in)	$d_a$ (in)	$\lambda_a$	$f_c$ (psi)	$c_{a1}$ (in)	$V_{by}$ (lb)
3.00	0.375	1.00	2500	7.25	6342

$\phi V_{cbgx} = \phi (2)(A_{Vc} / A_{Vco}) \psi_{ec,v} \psi_{ed,v} \psi_{c,v} \psi_{h,v} V_{by}$  (Sec. 17.3.1, 17.5.2.1(c) & Eq. 17.5.2.1b)

$A_{Vc}$ (in <sup>2</sup> )	$A_{Vco}$ (in <sup>2</sup> )	$\psi_{ec,v}$	$\psi_{ed,v}$	$\psi_{c,v}$	$\psi_{h,v}$	$V_{by}$ (lb)	$\phi$	$\phi V_{cbgx}$ (lb)
261.00	236.53	1.000	1.000	1.000	1.000	6342	0.70	9797

**Shear parallel to edge in y-direction:**

$V_{bx} = \min|7(l_e / d_a)^{0.2} \sqrt{d_a} \lambda_a \sqrt{f_c} c_{a1}^{1.5}; 9 \lambda_a \sqrt{f_c} c_{a1}^{1.5}|$  (Eq. 17.5.2.2a & Eq. 17.5.2.2b)

$l_e$ (in)	$d_a$ (in)	$\lambda_a$	$f_c$ (psi)	$c_{a1}$ (in)	$V_{bx}$ (lb)
3.00	0.375	1.00	2500	10.25	10661

$\phi V_{cbgy} = \phi (2)(A_{Vc} / A_{Vco}) \psi_{ec,v} \psi_{ed,v} \psi_{c,v} \psi_{h,v} V_{bx}$  (Sec. 17.3.1, 17.5.2.1(c) & Eq. 17.5.2.1b)

$A_{Vc}$ (in <sup>2</sup> )	$A_{Vco}$ (in <sup>2</sup> )	$\psi_{ec,v}$	$\psi_{ed,v}$	$\psi_{c,v}$	$\psi_{h,v}$	$V_{bx}$ (lb)	$\phi$	$\phi V_{cbgy}$ (lb)
401.67	472.78	1.000	1.000	1.000	1.000	10661	0.70	12680

**10. Concrete Pryout Strength of Anchor in Shear (Sec. 17.5.3)**

$\phi V_{cp} = \phi \min|k_{cp} N_{ba}; k_{cp} N_{cbg}| = \phi \min|k_{cp} (A_{Na} / A_{Na0}) \psi_{ec,Na} \psi_{ed,Na} \psi_{cp,Na} N_{ba}; k_{cp} (A_{Nc} / A_{Nco}) \psi_{ec,N} \psi_{ed,N} \psi_{c,N} \psi_{cp,N} N_b|$  (Sec. 17.3.1 & Eq. 17.5.3.1b)

$k_{cp}$	$A_{Na}$ (in <sup>2</sup> )	$A_{Na0}$ (in <sup>2</sup> )	$\psi_{ed,Na}$	$\psi_{ec,Na}$	$\psi_{cp,Na}$	$N_{ba}$ (lb)	$N_a$ (lb)
2.0	198.45	112.09	1.000	1.000	1.000	6343	11230

$A_{Nc}$ (in <sup>2</sup> )	$A_{Nco}$ (in <sup>2</sup> )	$\psi_{ec,N}$	$\psi_{ed,N}$	$\psi_{c,N}$	$\psi_{cp,N}$	$N_b$ (lb)	$N_{cb}$ (lb)	$\phi$
240.25	144.00	1.000	1.000	1.000	1.000	6800	11345	0.70

Input data and results must be checked for agreement with the existing circumstances, the standards and guidelines must be checked for plausibility.



Company:		Date:	5/14/2018
Engineer:		Page:	6/6
Project:			
Address:			
Phone:			
E-mail:			

$\phi V_{cpq}$  (lb)  
15722

## 11. Results

### Interaction of Tensile and Shear Forces (Sec. R17.6)

Tension	Factored Load, $N_{ua}$ (lb)	Design Strength, $\phi N_n$ (lb)	Ratio	Status	
Steel	985	3394	0.29	Pass	
Concrete breakout	3940	7374	0.53	Pass	
<b>Adhesive</b>	<b>3940</b>	<b>6176</b>	<b>0.64</b>	<b>Pass (Governs)</b>	
Shear	Factored Load, $V_{ua}$ (lb)	Design Strength, $\phi V_n$ (lb)	Ratio	Status	
Steel	675	1765	0.38	Pass	
T Concrete breakout x+	570	7103	0.08	Pass	
T Concrete breakout y-	2640	5313	0.50	Pass	
Concrete breakout y-	285	9797	0.03	Pass	
Concrete breakout x-	1320	12680	0.10	Pass	
<b>Concrete breakout, combined</b>	<b>-</b>	<b>-</b>	<b>0.50</b>	<b>Pass (Governs)</b>	
Pryout	2701	15722	0.17	Pass	
Interaction check	$(N_{ua}/\phi N_{ua})^{5/3}$	$(V_{ua}/\phi V_{ua})^{5/3}$	Combined Ratio	Permissible	Status
Sec. R17.6	0.47	0.32	79.1%	1.0	Pass

**SET-3G w/ 3/8"Ø F1554 Gr. 36 with hef = 4.000 inch meets the selected design criteria.**

## 12. Warnings

- Designer must exercise own judgement to determine if this design is suitable.
- Refer to manufacturer's product literature for hole cleaning and installation instructions.



JOB NO.: U2716-098-191

DESIGNED: STB

---

# Framing Analysis

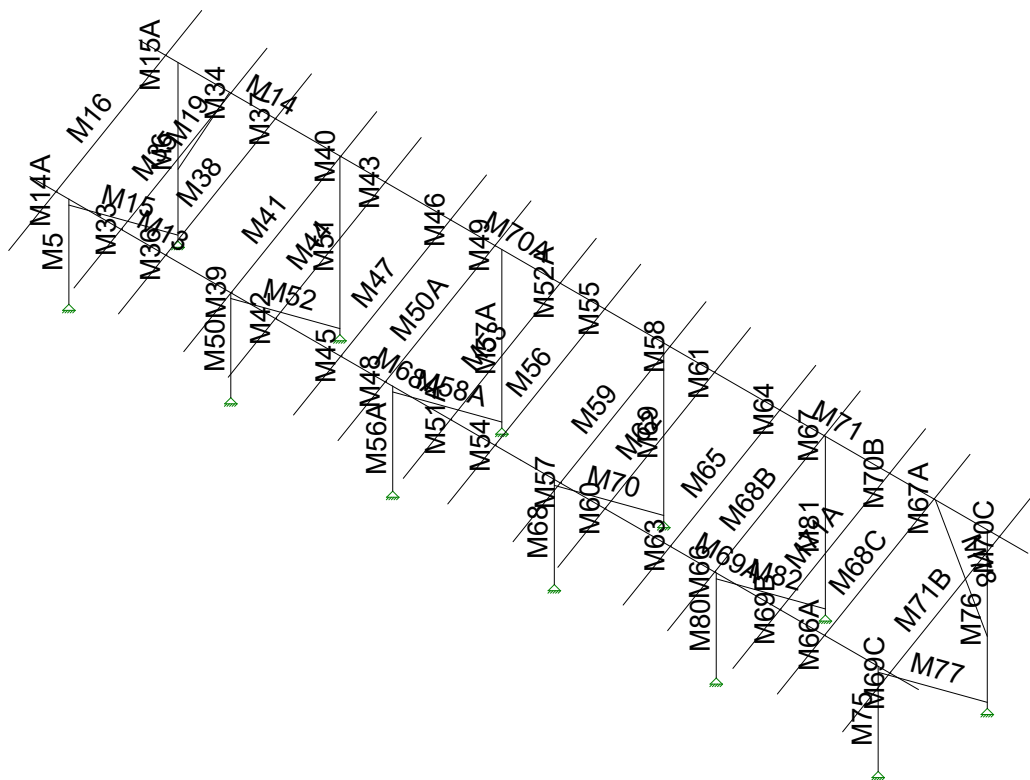

Vector Structural Engineeri...

STB

U2716.098.191

Ground Mount

SK - 3

July 29, 2019 at 12:26 PM

California C1 GM v4.r3d

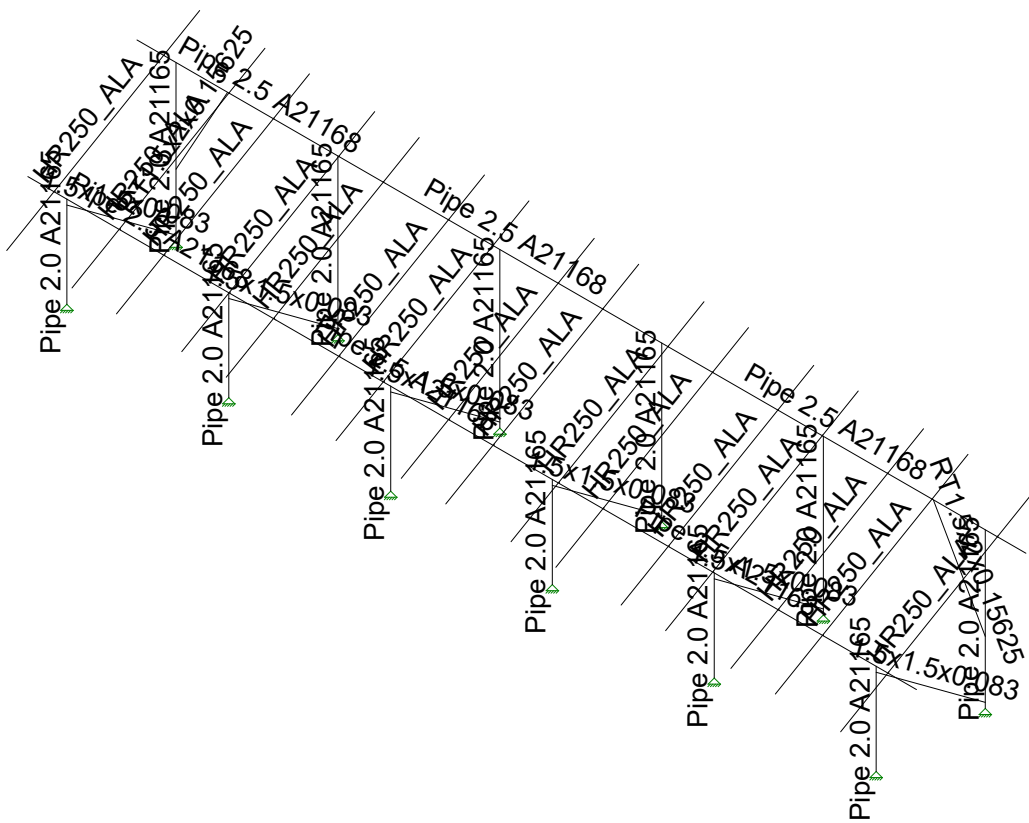

Vector Structural Engineeri...  
STB  
U2716.098.191

Ground Mount

SK - 4  
July 29, 2019 at 12:26 PM  
California C1 GM v4.r3d

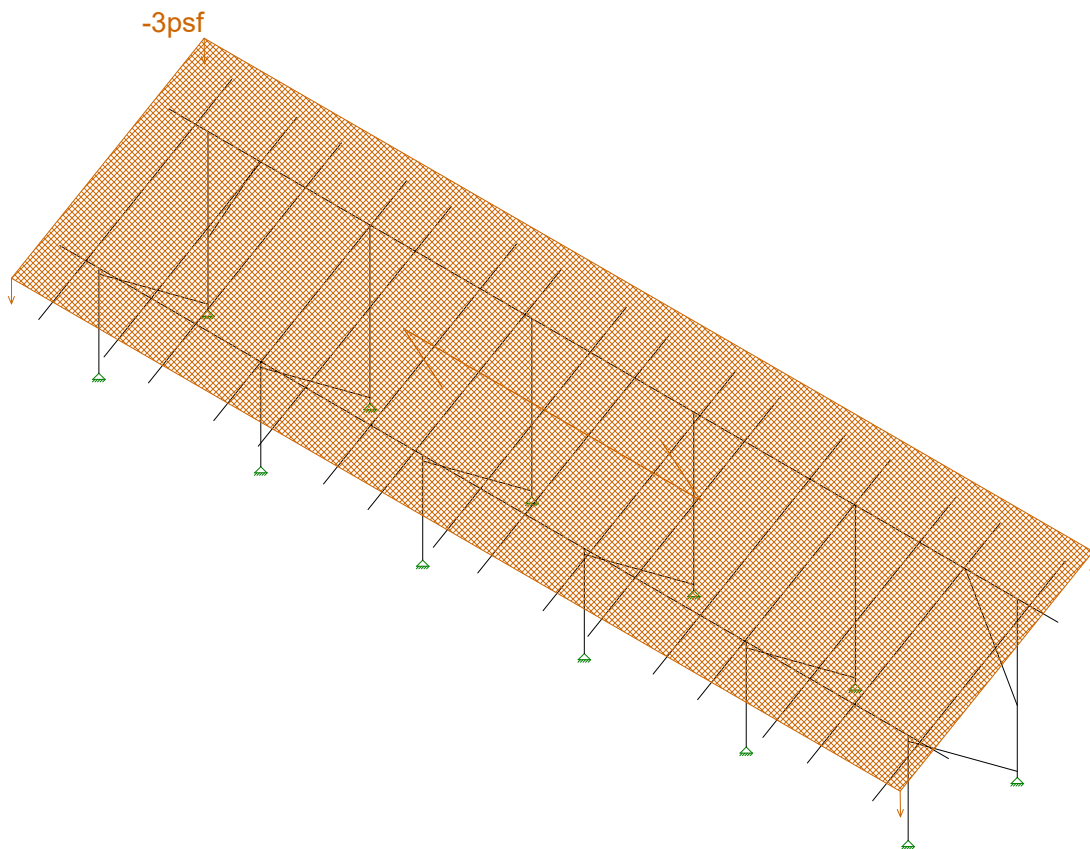

Loads: BLC 2, Solar Panel Weight

Vector Structural Engineeri..	Ground Mount	SK - 5
STB		July 29, 2019 at 12:26 PM
U2716.098.191		California C1 GM v4.r3d

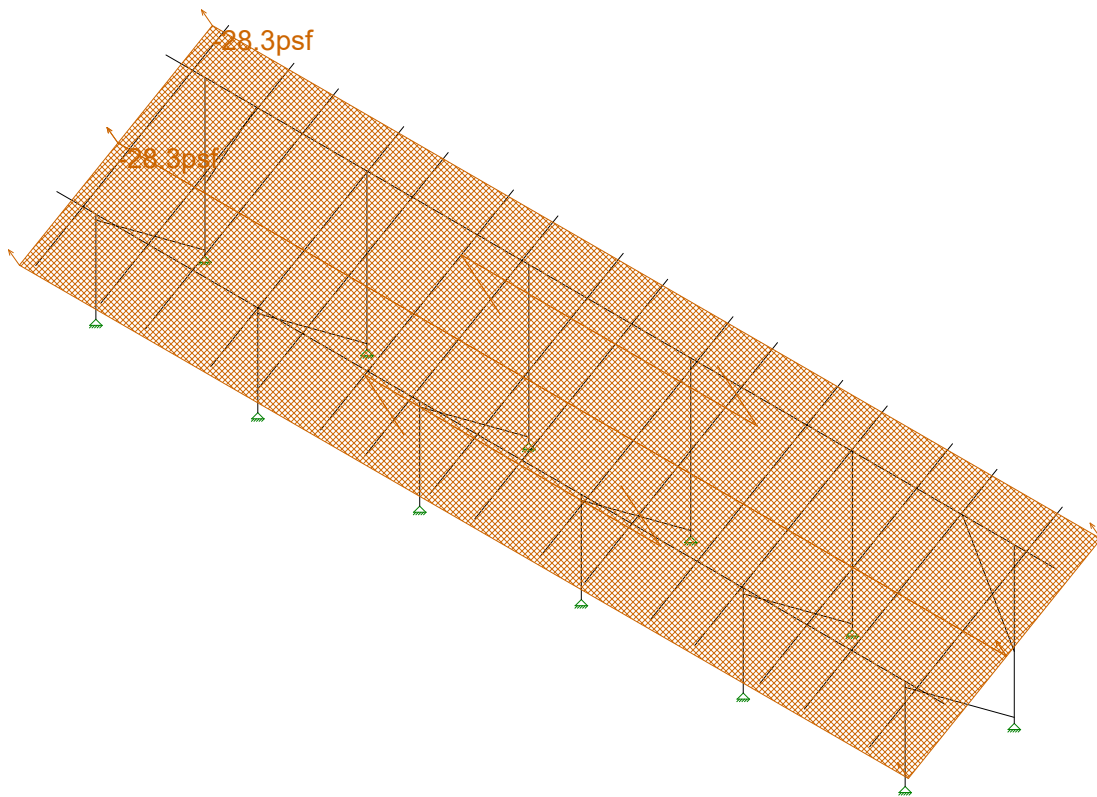

Loads: BLC 4, Wind A 0 deg

Vector Structural Engineeri..

STB

U2716.098.191

Ground Mount

SK - 6

July 29, 2019 at 12:26 PM

California C1 GM v4.r3d



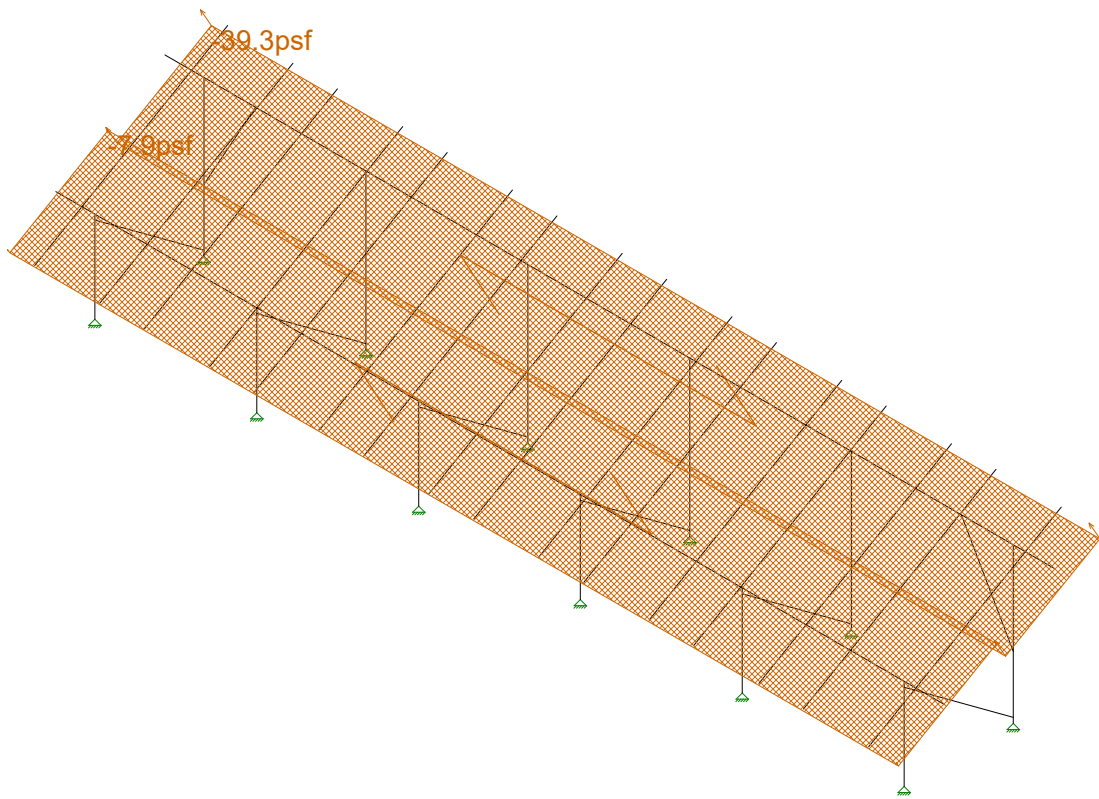

Loads: BLC 5, Wind B 0 deg

Vector Structural Engineeri..

STB

U2716.098.191

Ground Mount

SK - 7

July 29, 2019 at 12:26 PM

California C1 GM v4.r3d

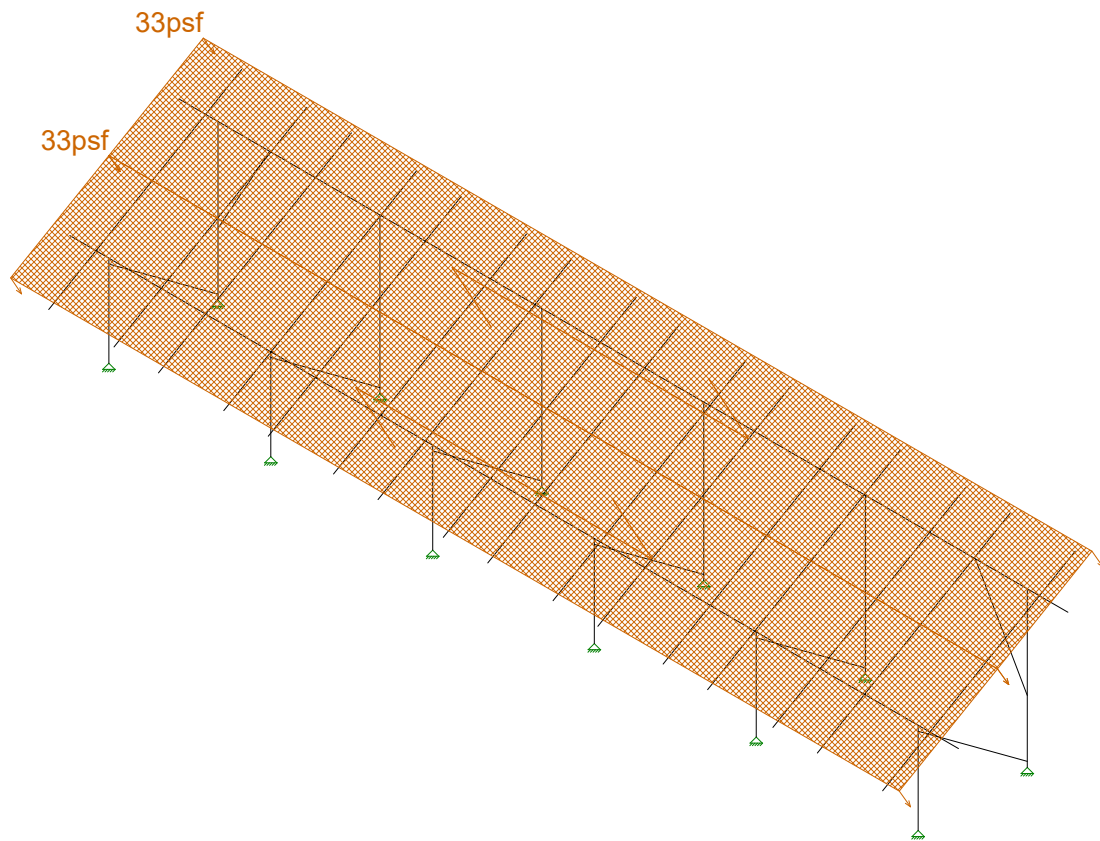

Loads: BLC 6, Wind A 180 deg

Vector Structural Engineeri..

STB

U2716.098.191

Ground Mount

SK - 8

July 29, 2019 at 12:26 PM

California C1 GM v4.r3d

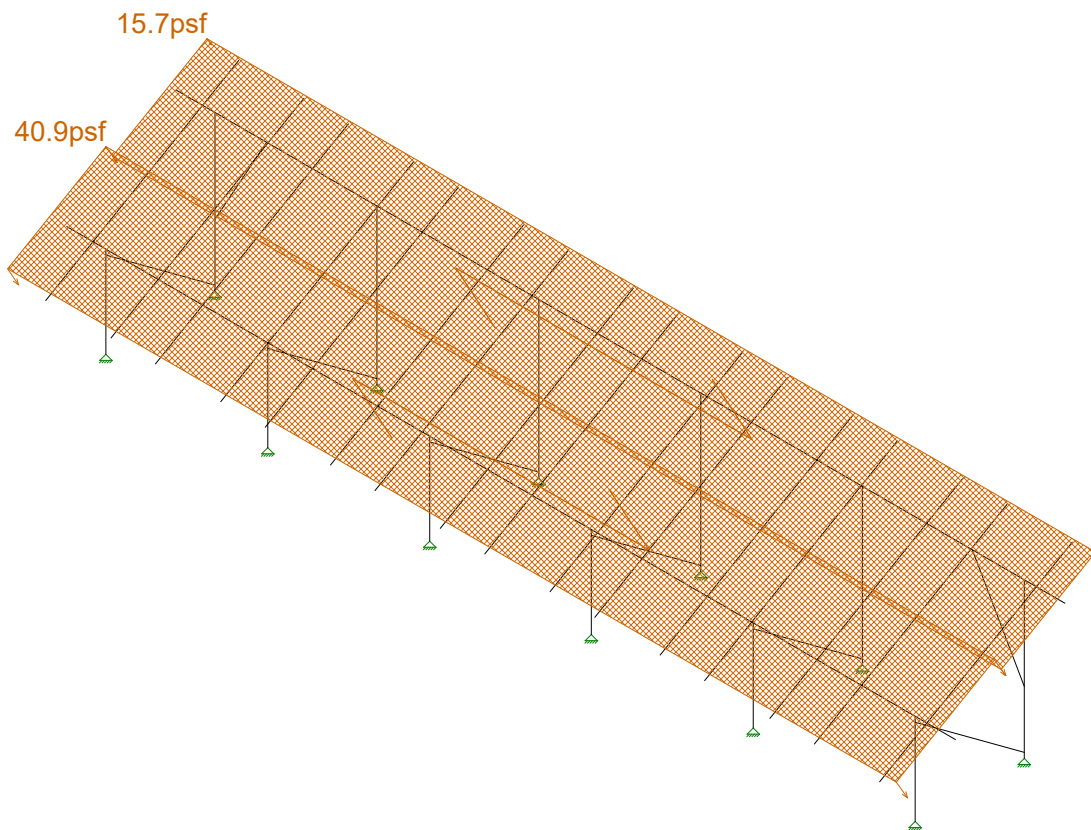

Loads: BLC 7, Wind B 180 deg

Vector Structural Engineeri..

STB

U2716.098.191

Ground Mount

SK - 9

July 29, 2019 at 12:26 PM

California C1 GM v4.r3d

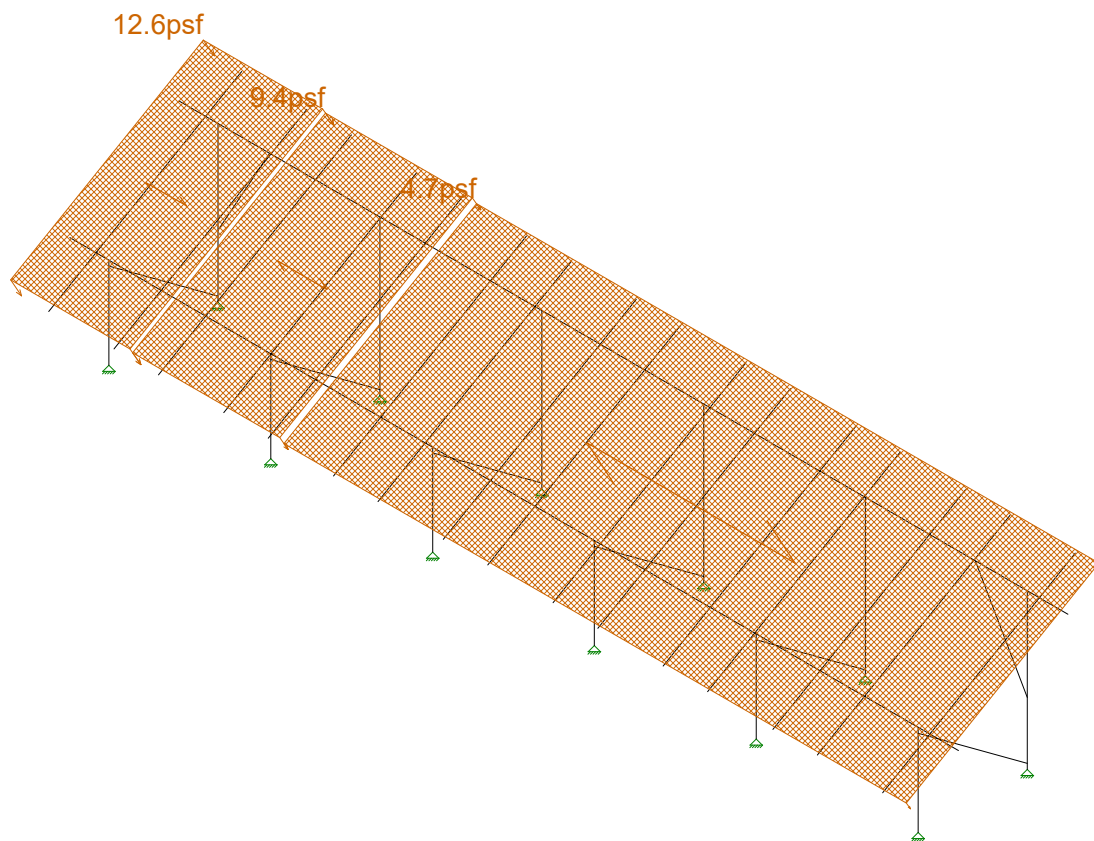

Loads: BLC 8, Wind A 90

Vector Structural Engineeri..	Ground Mount	SK - 10
STB		July 29, 2019 at 12:27 PM
U2716.098.191		California C1 GM v4.r3d

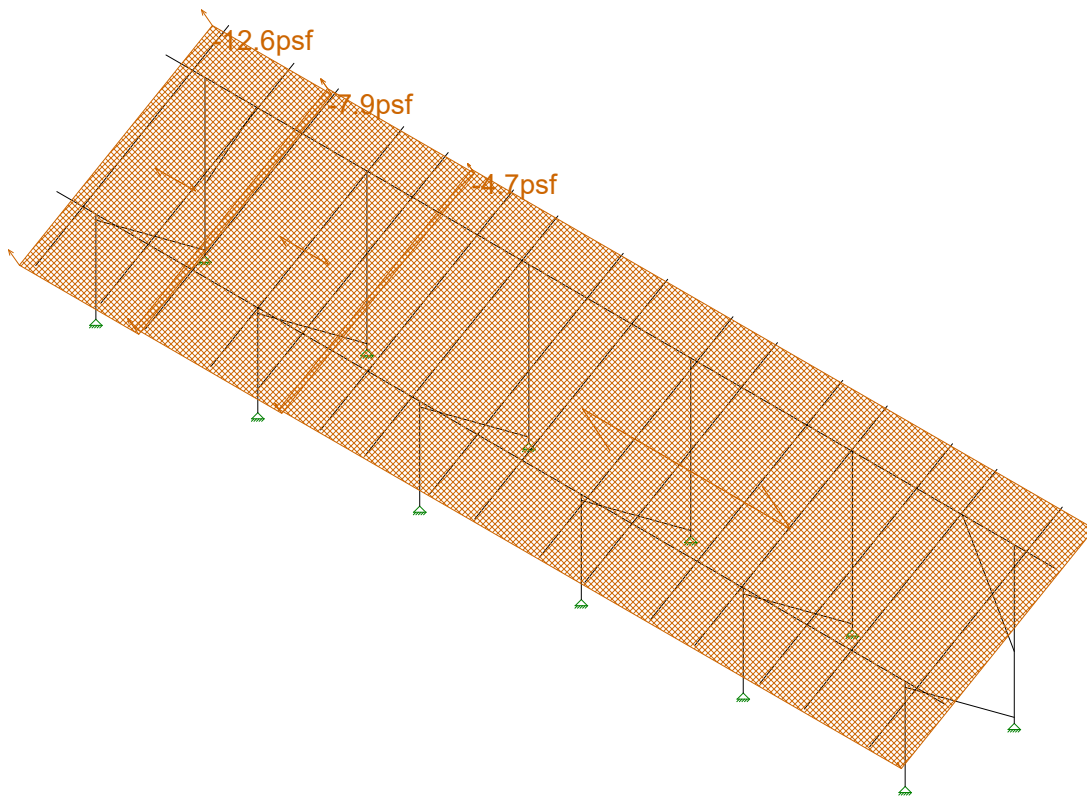

Loads: BLC 9, Wind B 90

Vector Structural Engineeri..	Ground Mount	SK - 11
STB		July 29, 2019 at 12:27 PM
U2716.098.191		California C1 GM v4.r3d



Code Check (Enr)
No Calc
> 1.0
40-1.0
75-90
50-75
0-.50

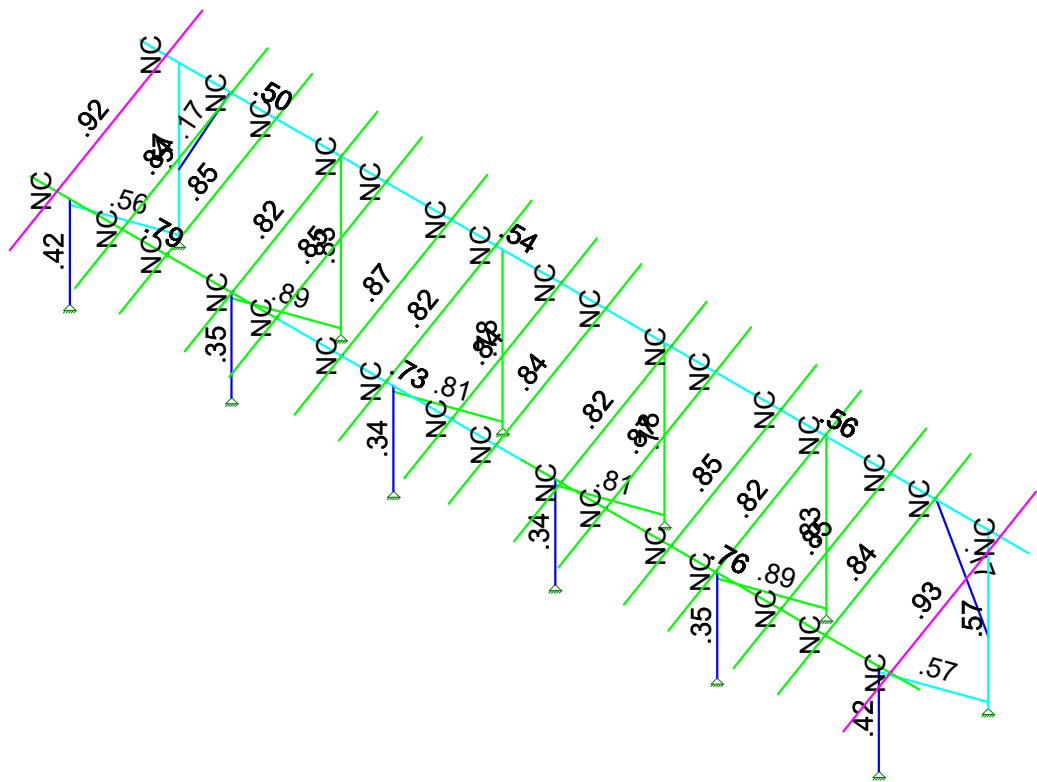

Member Code Checks Displayed (Enveloped)  
Envelope Only Solution

Vector Structural Engineeri...	Ground Mount	SK - 1
STB		July 29, 2019 at 12:25 PM
U2716.098.191		California C1 GM v4.r3d

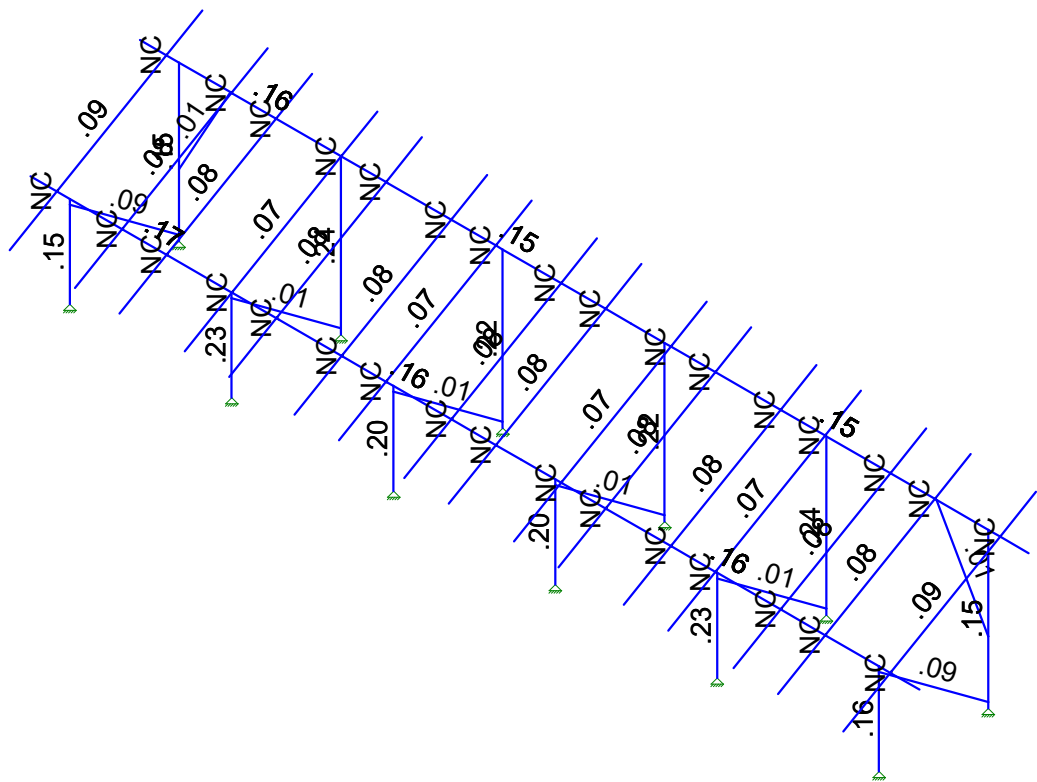

Member Shear Checks Displayed (Enveloped)  
Envelope Only Solution

Vector Structural Engineeri...	Ground Mount	SK - 2
STB		July 29, 2019 at 12:25 PM
U2716.098.191		California C1 GM v4.r3d



Company : Vector Structural Engineering  
 Designer : STB  
 Job Number : U2716.099.191  
 Model Name : Ground Mount

July 29, 2019  
 5:11 PM  
 Checked By: \_\_\_\_\_

**(Global) Model Settings**

Display Sections for Member Calcs	5
Max Internal Sections for Member Calcs	97
Include Shear Deformation?	Yes
Increase Nailing Capacity for Wind?	Yes
Include Warping?	Yes
Trans Load Btwn Intersecting Wood Wall?	Yes
Area Load Mesh (in^2)	144
Merge Tolerance (in)	.12
P-Delta Analysis Tolerance	0.50%
Include P-Delta for Walls?	Yes
Automatically Iterate Stiffness for Walls?	Yes
Max Iterations for Wall Stiffness	3
Gravity Acceleration (in/sec^2)	386.4
Wall Mesh Size (in)	24
Eigensolution Convergence Tol. (1.E-)	4
Vertical Axis	Y
Global Member Orientation Plane	XZ
Static Solver	Sparse Accelerated
Dynamic Solver	Accelerated Solver

Hot Rolled Steel Code	AISC 14th(360-10): ASD
Adjust Stiffness?	Yes(Iterative)
RISACONNECTION CODE	AISC 14th(360-10): ASD
Cold Formed Steel Code	AISI S100-16: ASD
Wood Code	AWC NDS-15: ASD
Wood Temperature	< 100F
Concrete Code	ACI 318-14
Masonry Code	ACI 530-13: ASD
Aluminum Code	AA ADM1-15: ASD - Building AISC 14th(360-10): ASD

Number of Shear Regions	4
Region Spacing Increment (in)	4
Biaxial Column Method	Exact Integration
Parme Beta Factor (PCA)	.65
Concrete Stress Block	Rectangular
Use Cracked Sections?	Yes
Use Cracked Sections Slab?	No
Bad Framing Warnings?	No
Unused Force Warnings?	Yes
Min 1 Bar Diam. Spacing?	No
Concrete Rebar Set	REBAR SET ASTMA615
Min % Steel for Column	1
Max % Steel for Column	8





Company : Vector Structural Engineering  
 Designer : STB  
 Job Number : U2716.099.191  
 Model Name : Ground Mount

July 29, 2019  
 5:11 PM  
 Checked By: \_\_\_\_\_

**(Global) Model Settings, Continued**

Seismic Code	ASCE 7-10
Seismic Base Elevation (in)	15600
Add Base Weight?	Yes
Ct X	.02
Ct Z	.02
T X (sec)	Not Entered
T Z (sec)	Not Entered
R X	3
R Z	3
Ct Exp. X	.75
Ct Exp. Z	.75
SD1	1
SDS	1
S1	1
TL (sec)	5
Risk Cat	I or II
Drift Cat	Other
Om Z	1
Om X	1
Cd Z	4
Cd X	4
Rho Z	1
Rho X	1

**Hot Rolled Steel Properties**

	Label	E [ksi]	G [ksi]	Nu	Therm (1E5 F)	Density[lb/ft^3]	Yield[psi]	Ry	Fu[psi]	Rt
1	A992	29000	11154	.3	.65	490	50000	1.1	65000	1.1
2	A36 Gr.36	29000	11154	.3	.65	490	36000	1.5	58000	1.2
3	A572 Gr.50	29000	11154	.3	.65	490	50000	1.1	65000	1.1
4	A500 Gr.B R...	29000	11154	.3	.65	527	42000	1.4	58000	1.3
5	A500 Gr.B Re...	29000	11154	.3	.65	527	46000	1.4	58000	1.3
6	A53 Gr.B	29000	11154	.3	.65	490	35000	1.6	60000	1.2
7	A1085	29000	11154	.3	.65	490	50000	1.4	65000	1.3

**Aluminum Properties**

	Label	E [ksi]	G [ksi]	Nu	Therm (...Density[... Table B.4	kt	Ftu[psi]	Fty[psi]	Fcy[psi]	Fsu[psi]	Ct
1	3003-H14	10100	3787.5	.33	1.3 172.8 Table B.4-1	1	19000	16000	13000	12000	141
2	6061-T6	10100	3787.5	.33	1.3 172.8 Table B.4-2	1	38000	35000	35000	24000	141
3	6063-T5	10100	3787.5	.33	1.3 172.8 Table B.4-2	1	22000	16000	16000	13000	141
4	6063-T6	10100	3787.5	.33	1.3 172.8 Table B.4-2	1	30000	25000	25000	19000	141
5	5052-H34	10200	3787.5	.33	1.3 172.8 Table B.4-1	1	34000	26000	24000	20000	141
6	6061-T6 W	10100	3787.5	.33	1.3 172.8 Table B.4-1	1	24000	15000	15000	15000	141
7	6005-T5	10100	3787.5	.33	1.3 172.8 Table B.4-1	1	38000	35000	35000	24000	141

**Hot Rolled Steel Section Sets**

	Label	Shape	Type	Design List	Material	Design R...	A [in <sup>2</sup> ]	Iyy [in <sup>4</sup> ]	Izz [in <sup>4</sup> ]	J [in <sup>4</sup> ]
1	Post	Pipe 2.0 A21165	Column	Pipe	A572 Gr.50	Typical	.776	.499	.499	.998
2	Cross Beam	Pipe 2.5 A21168	Beam	Wide Flange	A572 Gr.50	Typical	.947	.907	.907	1.814
3	Diagonal Brace	1.5x1.5x0.083	HBrace	SquareTube	A36 Gr.36	Typical	.47	.158	.158	.236



Company : Vector Structural Engineering  
 Designer : STB  
 Job Number : U2716.099.191  
 Model Name : Ground Mount

July 29, 2019  
 5:11 PM  
 Checked By: \_\_\_\_\_

**Aluminum Section Sets**

	Label	Shape	Type	Design List	Material	Design R...	A [in2]	Iyy [in4]	Izz [in4]	J [in4]
1	AL Posts	2.375ODX0.188	Column	Pipe	6005-T5	Typical	1.29	.778	.778	1.54
2	AL Brace	RT1.5x2x0.15625	VBrace	Rectangular Tubes	6005-T5	Typical	.996	.327	.524	.602
3	AL Rails	HR250 ALA	Beam	Rectangular Tubes	6005-T5	Typical	.723	.095	.486	.261
4	AL Cross Beam	Cross Rail	Beam	Rectangular Tubes	6005-T5	Typical	1.909	1.97	4.366	4.017

**Member Area Loads (BLC 2 : Solar Panel Weight)**

	Joint A	Joint B	Joint C	Joint D	Direction	Distribution	Magnitude[psf]
1	N197	N200	N199	N196	Y	A-B	-3

**Member Area Loads (BLC 3 : Roof Live/Snow)**

	Joint A	Joint B	Joint C	Joint D	Direction	Distribution	Magnitude[psf]
1	N197	N200	N199	N196	PY	A-B	0

**Member Area Loads (BLC 4 : Wind A 0 deg)**

	Joint A	Joint B	Joint C	Joint D	Direction	Distribution	Magnitude[psf]
1	N197	N200	N201	N198	Perp	A-B	-28.3
2	N198	N201	N199	N196	Perp	A-B	-28.3

**Member Area Loads (BLC 5 : Wind B 0 deg)**

	Joint A	Joint B	Joint C	Joint D	Direction	Distribution	Magnitude[psf]
1	N197	N200	N201	N198	Perp	A-B	-39.3
2	N198	N201	N199	N196	Perp	A-B	-7.9

**Member Area Loads (BLC 6 : Wind A 180 deg)**

	Joint A	Joint B	Joint C	Joint D	Direction	Distribution	Magnitude[psf]
1	N197	N200	N201	N198	Perp	A-B	33
2	N198	N201	N199	N196	Perp	A-B	33

**Member Area Loads (BLC 7 : Wind B 180 deg)**

	Joint A	Joint B	Joint C	Joint D	Direction	Distribution	Magnitude[psf]
1	N197	N200	N201	N198	Perp	A-B	15.7
2	N198	N201	N199	N196	Perp	A-B	40.9

**Member Area Loads (BLC 8 : Wind A 90)**

	Joint A	Joint B	Joint C	Joint D	Direction	Distribution	Magnitude[psf]
1	N197	N203	N202	N196	Perp	A-B	12.6
2	N203	N209	N208	N202	Perp	A-B	9.4
3	N209	N200	N199	N208	Perp	A-B	4.7

**Member Area Loads (BLC 9 : Wind B 90)**

	Joint A	Joint B	Joint C	Joint D	Direction	Distribution	Magnitude[psf]
1	N197	N203	N202	N196	Perp	A-B	-12.6
2	N203	N209	N208	N202	Perp	A-B	-7.9
3	N209	N200	N199	N208	Perp	A-B	-4.7

**Basic Load Cases**

	BLC Description	Category	X Gravity	Y Gravity	Z Gravity	Joint	Point	Distributed	Area(M...Surface...
1	Self Weight	DL		-1.05					
2	Solar Panel Weight	DL							1



Company : Vector Structural Engineering  
 Designer : STB  
 Job Number : U2716.099.191  
 Model Name : Ground Mount

July 29, 2019  
 5:11 PM  
 Checked By: \_\_\_\_\_

**Basic Load Cases (Continued)**

	BLC Description	Category	X Gravity	Y Gravity	Z Gravity	Joint	Point	Distributed	Area(M... Surface...
3	Roof Live/Snow	RLL							1
4	Wind A 0 deg	OL1							2
5	Wind B 0 deg	OL2							2
6	Wind A 180 deg	OL3							2
7	Wind B 180 deg	OL4							2
8	Wind A 90	OL5							3
9	Wind B 90	OL6							3
10	BLC 2 Transient Area ...	None						36	
11	BLC 3 Transient Area ...	None							
12	BLC 4 Transient Area ...	None						96	
13	BLC 5 Transient Area ...	None						96	
14	BLC 6 Transient Area ...	None						96	
15	BLC 7 Transient Area ...	None						96	
16	BLC 8 Transient Area ...	None						84	
17	BLC 9 Transient Area ...	None						84	

**Load Combinations**

	Description	S...	PD...	SRSS	BLC Fa...	BLC Fa...	BLC Fa...	B...	B...	B...	B...	B...	B...	B...	B...	B...	B...	B...	B...
1	1.0 D	Yes	Y		DL 1														
2	1.0 D + 1.0 S	Yes	Y		DL 1	RLL 1													
3	1.0 D + 0.6 W1	Yes	Y		DL 1	RLL	OL1	.6											
4	1.0 D + 0.6 W2	Yes	Y		DL 1	RLL	OL2	.6											
5	1.0 D + 0.6 W3	Yes	Y		DL 1	RLL	OL3	.6											
6	1.0 D + 0.6 W4	Yes	Y		DL 1	RLL	OL4	.6											
7	1.0 D + 0.6 W5	Yes	Y		DL 1	RLL	OL5	.6											
8	1.0 D + 0.6 W6	Yes	Y		DL 1	RLL	OL6	.6											
9	1.0 D + 0.45 W1 + 0....	Yes	Y		DL 1	RLL	.75 OL1	.45											
10	1.0 D + 0.45 W2 + 0....	Yes	Y		DL 1	RLL	.75 OL2	.45											
11	1.0 D + 0.45 W3 + 0....	Yes	Y		DL 1	RLL	.75 OL3	.45											
12	1.0 D + 0.45 W4 + 0....	Yes	Y		DL 1	RLL	.75 OL4	.45											
13	1.0 D + 0.45 W5 + 0....	Yes	Y		DL 1	RLL	.75 OL5	.45											
14	1.0 D + 0.45 W6 + 0....	Yes	Y		DL 1	RLL	.75 OL6	.45											
15	0.6 D + 0.6 W1	Yes	Y		DL .6	RLL	OL1	.6											
16	0.6 D + 0.6 W2	Yes	Y		DL .6	RLL	OL2	.6											
17	0.6 D + 0.6 W3	Yes	Y		DL .6	RLL	OL3	.6											
18	0.6 D + 0.6 W4	Yes	Y		DL .6	RLL	OL4	.6											
19	0.6 D + 0.6 W5	Yes	Y		DL .6	RLL	OL5	.6											
20	0.6 D + 0.6 W6	Yes	Y		DL .6	RLL	OL6	.6											

**Envelope Joint Reactions**

	Joint	X [lb]	LC	Y [lb]	LC	Z [lb]	LC	MX [lb-ft]	LC	MY [lb-ft]	LC	MZ [lb-ft]	LC
1	N2	max 80.325	6	739	4	54.727	3	0	1	0	1	0	1
2		min -42.141	15	28.97	17	-65.303	5	0	1	0	1	0	1
3	N1	max 111.171	5	2035.281	5	972.8	5	0	1	0	1	0	1
4		min -109.778	16	-1648.177	16	-832.255	3	0	1	0	1	0	1
5	N132	max 3.015	16	2917.075	5	1570.8...	5	0	1	0	1	0	1
6		min -2.264	7	-2349.285	16	-1346....	3	0	1	0	1	0	1
7	N133	max 12.617	6	1196.339	4	72.554	3	0	1	0	1	0	1
8		min -5.808	15	-64.661	17	-85.871	5	0	1	0	1	0	1
9	N109	max 2.73	8	2922.211	5	1573.2...	5	0	1	0	1	0	1
10		min -2.797	16	-2353.09	16	-1348....	3	0	1	0	1	0	1
11	N110A	max 6.223	15	1197.931	4	72.509	3	0	1	0	1	0	1
12		min -13.784	6	-65.11	17	-85.805	5	0	1	0	1	0	1
13	N121	max 2.554	16	2797.219	5	1423.1...	5	0	1	0	1	0	1



**Envelope Joint Reactions (Continued)**

Joint	X [lb]	LC	Y [lb]	LC	Z [lb]	LC	MX [lb-ft]	LC	MY [lb-ft]	LC	MZ [lb-ft]	LC
14	min -2.216	5	-2276.254	16	-1218....	3	0	1	0	1	0	1
15	N122 max .833	17	1074.972	4	71.547	3	0	1	0	1	0	1
16	min -1.729	4	2.901	17	-85.234	5	0	1	0	1	0	1
17	N133B max 2.554	5	2797.487	5	1423.1...	5	0	1	0	1	0	1
18	min -2.44	16	-2276.111	16	-1218....	3	0	1	0	1	0	1
19	N134B max 1.659	4	1074.421	4	71.548	3	0	1	0	1	0	1
20	min -1.575	19	3.385	17	-85.242	5	0	1	0	1	0	1
21	N155 max 109.64	16	2063.055	5	986.934	5	0	1	0	1	0	1
22	min -110.948	5	-1671.738	16	-844.336	3	0	1	0	1	0	1
23	N156 max 41.395	15	750.403	4	55.26	3	0	1	0	1	0	1
24	min -79.089	6	28.506	17	-65.936	5	0	1	0	1	0	1
25	Totals: max .027	8	16140.801	5	7476.7...	17						
26	min -.033	7	-9190.301	15	-6411.87	3						

**Envelope AISC 14th(360-10): ASD Steel Code Checks**

Member	Shape	Code Check	Loc[in]	LC	Shear ...	Loc[in]	Dir	LC	Pnc/om [...]	Pnt/om [lb]	Mnyy/om...	Mnzz/om...Cb	Eqn
1	M5	Pipe 2.0 A2...	.418	64.064	6	.153	64.064	5	13824.088	23232.186	1397.505	1397.505	1...H1-1b
2	M6	Pipe 2.0 A2...	.569	45.403	5	.149	0	5	5702.924	23232.186	1397.505	1397.505	1...H1-1a
3	M13	Pipe 2.5 A2...	.794	147....	6	.170	149.5	6	11641.036	28358.413	2081.747	2081.747	1...H1-1b
4	M14	Pipe 2.5 A2...	.504	149.5	5	.161	149.5	5	11641.036	28358.413	2081.747	2081.747	1...H1-1b
5	M15	1.5x1.5x0.083	.560	52.434	5	.093	0	y 5	2342.799	10141.308	449.583	449.583	1...H1-1a
6	M80	Pipe 2.0 A2...	.347	64.064	5	.226	64.064	5	13824.088	23232.186	1397.505	1397.505	1...H1-1b
7	M81	Pipe 2.0 A2...	.830	3.584	5	.241	0	5	5702.924	23232.186	1397.505	1397.505	1...H1-1a
8	M82	1.5x1.5x0.083	.891	52.434	5	.007	100....	y 7	2342.799	10141.308	449.583	449.583	1...H1-1a
9	M50	Pipe 2.0 A2...	.348	64.064	5	.227	64.064	5	13824.088	23232.186	1397.505	1397.505	1...H1-1b
10	M51	Pipe 2.0 A2...	.832	3.584	5	.241	0	5	5702.924	23232.186	1397.505	1397.505	1...H1-1a
11	M52	1.5x1.5x0.083	.893	52.434	5	.009	100....	y 7	2342.799	10141.308	449.583	449.583	1...H1-1a
12	M56A	Pipe 2.0 A2...	.343	64.064	5	.204	64.064	5	13824.088	23232.186	1397.505	1397.505	1...H1-1b
13	M57A	Pipe 2.0 A2...	.779	3.584	5	.218	0	5	5702.924	23232.186	1397.505	1397.505	1...H1-1a
14	M58A	1.5x1.5x0.083	.809	52.434	5	.006	0	y 7	2342.799	10141.308	449.583	449.583	1...H1-1a
15	M68	Pipe 2.0 A2...	.343	64.064	5	.204	64.064	5	13824.088	23232.186	1397.505	1397.505	1...H1-1b
16	M69	Pipe 2.0 A2...	.779	3.584	5	.218	0	5	5702.924	23232.186	1397.505	1397.505	1...H1-1a
17	M70	1.5x1.5x0.083	.809	52.434	5	.006	100....	y 4	2342.799	10141.308	449.583	449.583	1...H1-1a
18	M68A	Pipe 2.5 A2...	.726	84.375	6	.157	84.375	6	11641.036	28358.413	2081.747	2081.747	1...H1-1b
19	M69A	Pipe 2.5 A2...	.764	144....	6	.156	27.656	6	11641.036	28358.413	2081.747	2081.747	1...H1-1b
20	M70A	Pipe 2.5 A2...	.542	84.375	5	.152	84.375	5	11641.036	28358.413	2081.747	2081.747	1...H1-1b
21	M71	Pipe 2.5 A2...	.555	24.583	5	.151	27.656	5	11641.036	28358.413	2081.747	2081.747	1...H1-1b
22	M75	Pipe 2.0 A2...	.416	64.064	6	.155	64.064	5	13824.088	23232.186	1397.505	1397.505	1...H1-1b
23	M76	Pipe 2.0 A2...	.575	45.403	5	.151	0	5	5702.924	23232.186	1397.505	1397.505	1...H1-1a
24	M77	1.5x1.5x0.083	.568	52.434	5	.093	100....	y 5	2342.799	10141.308	449.583	449.583	1...H1-1a

**Envelope AA ADM1-15: ASD - Building Aluminum Code Checks**

Member	Shape	Code C...	Loc[in]	LC	Shear ...	Loc[in]	Dir	LC	Pnc/O...	Pnt/Om...	Mny/O...	Mnz/O...	Vny/O...	Vnz/O...	Cb	Eqn
1	M19	RT1.5x2x...	.174	46.527	5	.009	0	z 6	2734.821	19411....	770.742	927.083	6090.199	4101.563	1...	H.1-1
2	M16	HR250_A...	.921	41.257	6	.086	41.257	y 6	2221.164	14089....	309.506	613.954	5108.727	1672.364	1	H.1-1
3	M35	HR250_A...	.839	41.257	6	.083	41.257	y 6	2221.164	14089....	309.506	613.954	5108.727	1672.364	1	H.1-1
4	M38	HR250_A...	.850	41.257	6	.082	41.257	y 6	2221.164	14089....	309.506	613.954	5108.727	1672.364	1	H.1-1
5	M41	HR250_A...	.824	41.257	6	.072	41.257	y 6	2221.164	14089....	309.506	613.954	5108.727	1672.364	1	H.1-1
6	M44	HR250_A...	.846	41.257	6	.077	41.257	y 6	2221.164	14089....	309.506	613.954	5108.727	1672.364	1	H.1-1
7	M47	HR250_A...	.870	41.257	6	.075	41.257	y 6	2221.164	14089....	309.506	613.954	5108.727	1672.364	1	H.1-1
8	M50A	HR250_A...	.824	41.257	6	.070	41.257	y 6	2221.164	14089....	309.506	613.954	5108.727	1672.364	1	H.1-1
9	M53	HR250_A...	.845	41.257	6	.077	41.257	y 6	2221.164	14089....	309.506	613.954	5108.727	1672.364	1	H.1-1
10	M56	HR250_A...	.844	41.257	6	.077	41.257	y 6	2221.164	14089....	309.506	613.954	5108.727	1672.364	1	H.1-1
11	M59	HR250_A...	.824	41.257	6	.071	41.257	y 6	2221.164	14089....	309.506	613.954	5108.727	1672.364	1	H.1-1



Company : Vector Structural Engineering  
 Designer : STB  
 Job Number : U2716.099.191  
 Model Name : Ground Mount

July 29, 2019  
 5:11 PM  
 Checked By: \_\_\_\_\_

**Envelope AA ADM1-15: ASD - Building Aluminum Code Checks (Continued)**

Member	Shape	Code C...	Loc[fin]	LC	Shear ...	Loc[fin]	Dir	LC	Pnc/O...	Pnt/Om...	Mny/O...	Mnz/O...	Vny/O...	Vnz/O...	Cb	Eqn
12	M62	HR250_A...	.871	41.257	6	.075	41.257	y	6	2221.164	14089....	309.506	613.954	5108.727	1672.364	1 H.1-1
13	M65	HR250_A...	.846	41.257	6	.077	41.257	y	6	2221.164	14089....	309.506	613.954	5108.727	1672.364	1 H.1-1
14	M68B	HR250_A...	.824	41.257	6	.072	41.257	y	6	2221.164	14089....	309.506	613.954	5108.727	1672.364	1 H.1-1
15	M71A	HR250_A...	.850	41.257	6	.082	41.257	y	6	2221.164	14089....	309.506	613.954	5108.727	1672.364	1 H.1-1
16	M68C	HR250_A...	.838	41.257	6	.083	41.257	y	6	2221.164	14089....	309.506	613.954	5108.727	1672.364	1 H.1-1
17	M71B	HR250_A...	.934	41.257	6	.087	41.257	y	6	2221.164	14089....	309.506	613.954	5108.727	1672.364	1 H.1-1
18	M78	RT1.5x2x...	.175	46.599	5	.010	0	z	5	2726.33	19411....	770.742	927.083	6090.199	4101.563	1... H.1-1

NOTES: UNLESS OTHERWISE SPECIFIED  
 1. DIMENSIONS SHOWN ARE INCHES [MILIMETERS].

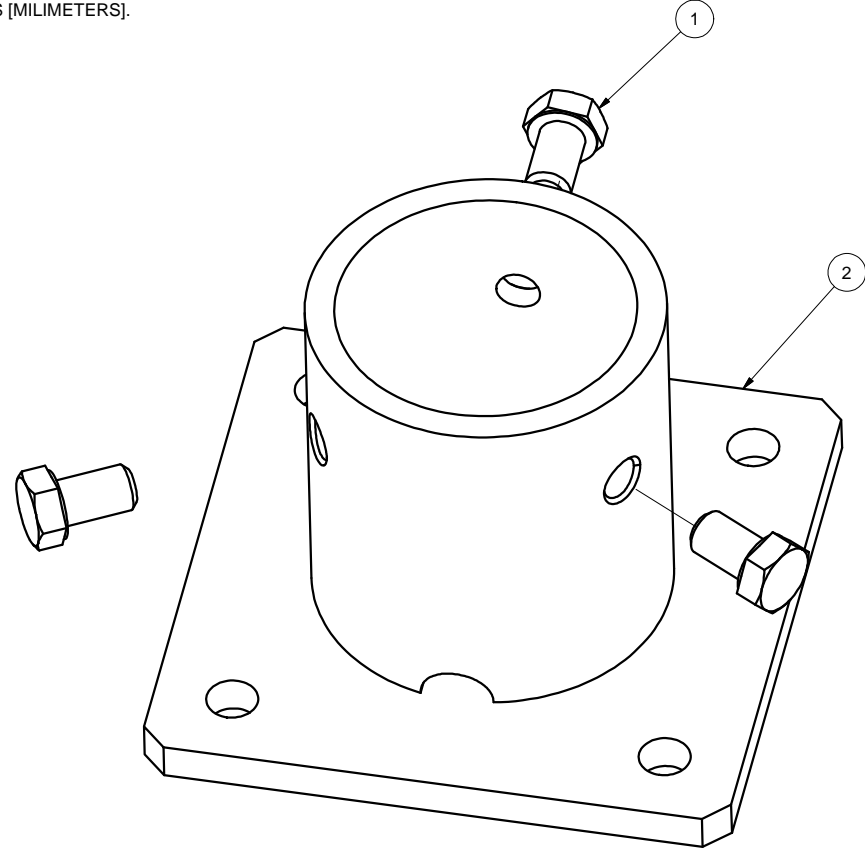

REVISIONS			
REV	DESCRIPTION	BY	DATE
A	INITIAL RELEASE	LWF	10/20/2016

2	A21120-001	2" PIPE BASE	1
1	B15018-011	HEX CAP SCREW 3/8-16 X 5/8	3
ITEM	PART NUMBER	DESCRIPTION	QTY
MATERIAL SEE NOTES			
Third Angle Projection:			
GENERAL SPECIFICATIONS		<b>Sunmodo Corp.</b> 1905 E 5TH STREET, STE A, VANCOUVER, WA 98661 TITLE 2" PIPE BASE KIT DRAWING NUMBER B K10268-001	
All Dimensions in inches [millimeters]			
Tolerances			
X.XXX ±0.01 [0.25mm] X.XX ±0.02 [0.50mm] X.X ±0.039 [1.0mm] Unless otherwise spec'd			
Break all sharp edges .010-.020 unless otherwise specified.			
DRAWN BY	DATE		
LWF	10/20/2016		
CHECKED BY			
APPROVALS		SCALE: NONE	SHEET 1 of 1

THIS DRAWING IS CONFIDENTIAL PROPERTY OF SUNMODO AND ITS CONTENTS MAY NOT BE DISCLOSED WITHOUT THE PRIOR WRITTEN CONSENT OF SUNMODO CORP.

NOTES: UNLESS OTHERWISE SPECIFIED

1. DIMENSIONS SHOWN ARE INCHES [MILIMETERS].
2. MATERAIL: ALUMINUM 6005-T5.  
FINISH: CLEAR ANODIZED 10  $\mu$ m THICK.
3. THE UNSPECIFIED DIMENSIONS ARE SPECIFIED BY 2D CAD FILE.

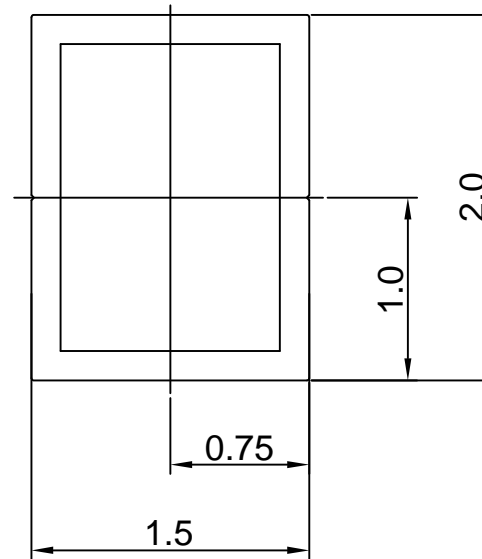

## Section properties:

Weight: 1.156 lbs/ft

Area: 0.992 in<sup>2</sup>

Perimeter: 12.601 in

Bounding Box: X: -1.000,1.000

Y: -0.750, 0.750

Centroid:(0.000,0.000)

Moments of Inertia(in<sup>4</sup>): I<sub>x</sub>=0.506,I<sub>y</sub>=0.322

Section modulus in bending(in<sup>3</sup>): W<sub>x</sub>=0.675,W<sub>y</sub>=0.322

Radii of Gyration: X: 0.714, Y: 0.570

MATERIAL		SEE NOTES	
Third Angle Projection:			
GENERAL SPECIFICATIONS			
All Dimensions in inches [millimeters]			
Tolerances			
X.XXX ± 0.01 [0.25mm]	Break all sharp edges		
X.XX ± 0.02 [0.50mm]	.010-.020 unless		
X.X ± 0.039 [1.0mm]	otherwise specified.		
DRAWN BY		DATE	
zcg		03/12/2014	
CHECKED BY		B	
APPROVALS		DRAWING NUMBER	
		A20164	
SCALE:		NONE	
SHEET		1 of 1	

**Sunmodo Corp.**

1905 E 5TH STREET, SUITE A, VANCOUVER, WA 98661

TITLE  
1.5X2 AL TUBE BRACE EXTRUSION

REVISIONS			
REV	DESCRIPTION	BY	DATE
A	ADDED BOTTOM CHANNEL & CHANGED ONE 3/8 CHANNEL TO 1/4	zcg	02/21/2013

NOTES: UNLESS OTHERWISE SPECIFIED

1. DIMENSIONS SHOWN ARE INCHES [MILIMETERS].
2. MATERAIL: ALUMINUM 6005-T5.  
FINISH: CLEAR ANODIZED 15  $\mu$ m THICK.
3. THE UNSPECIFIED DIMENSIONS ARE SPECIFIED BY 2D CAD FILE.

2X 1/4 BOLT SLOT

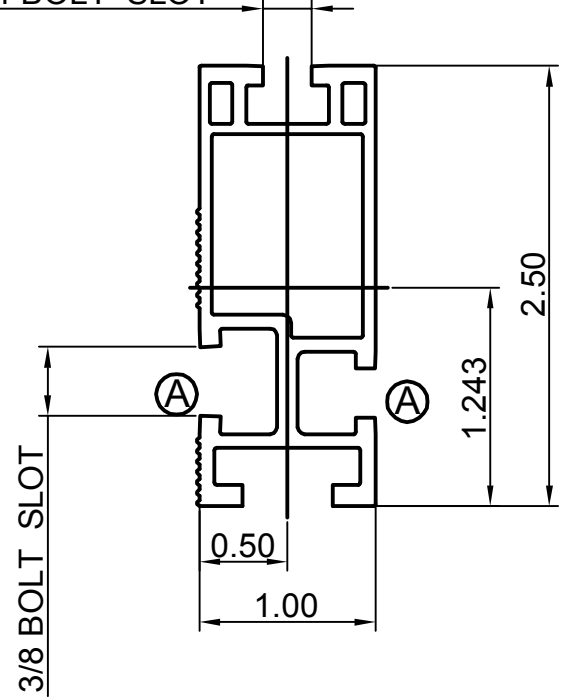

### Section properties:

Weight: 0.850 lbs/ft  
 Area: 0.723 in<sup>2</sup>  
 Perimeter: 17.325 in  
 Bounding Box: X: -0.500,0.500  
 Y: -1.243,1.257

Centroid:(0.000,0.000)  
 Moments of Incertia(in<sup>4</sup>): Ix=0.486,Iy=0.095  
 Section modulus in bending(in<sup>3</sup>): Wx=0.387,Wy=0.190  
 Radii of Gyration: X: 0.820, Y: 0.363

MATERIAL <b>SEE NOTES</b>		<b>Sunmodo Corp.</b>	
Third Angle Projection:			
GENERAL SPECIFICATIONS All Dimensions in inches [millimeters]		1905 E 5TH STREET, SUITE A, VANCOUVER, WA 98661	
Tolerances: X.XXX ± 0.01 [0.25mm] X.XX ± 0.02 [0.50mm] X.X ± 0.039 [1.0mm] Unless otherwise spec'd		TITLE HELIO STANDARD RAIL	
DRAWN BY zcg	DATE 02/21/2013	DRAWING NUMBER A20144	
CHECKED BY		SCALE: NONE SHEET 1 of 1	
APPROVALS			



NOTES: UNLESS OTHERWISE SPECIFIED

1. DIMENSIONS SHOWN ARE INCHES [MILIMETERS].
2. MATERIAL: 6005-T5.  
FINISH: CLEAR ANODIZED 10um THICK.
3. THE UNSPECIFIED RADII ARE .02" MAX.
4. THE UNSPECIFIED DIMENSIONS ARE SPECIFIED BY 2D CAD FILE.

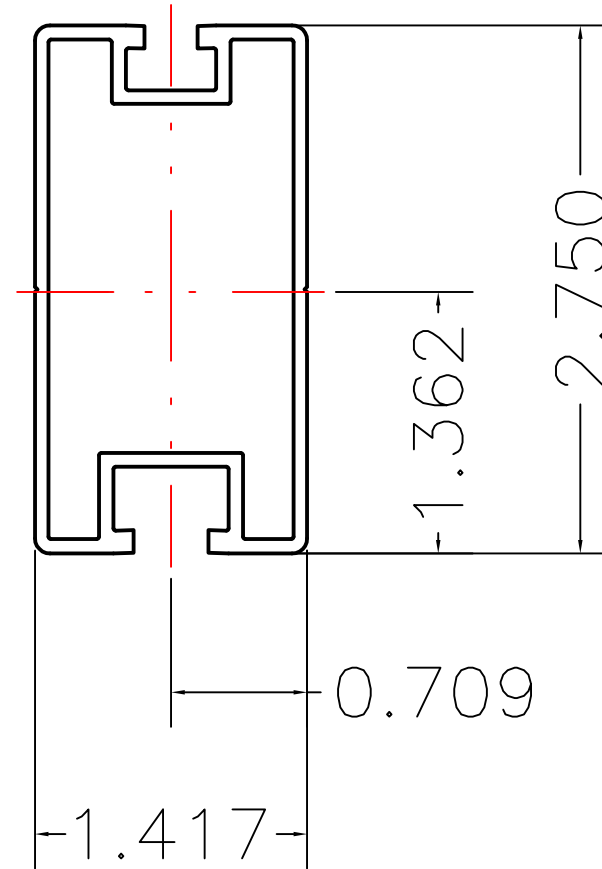

### Section properties:

Weight: 0.862 lbs/ft  
 Area: 0.736 in<sup>2</sup>  
 Perimeter: 19.824 in  
 Bounding Box: X: -0.709,0.709  
                   Y: -1.362,1.388  
 Centroid:(0.000,0.000)  
 Moments of Inertia(in<sup>4</sup>): I<sub>x</sub>=0.727,I<sub>y</sub>=0.214  
 Section modulus in bending(in<sup>3</sup>): W<sub>x</sub>=0.524,W<sub>y</sub>=0.302  
 Radii of Gyration: X: 994, Y: 0.539

THIS DRAWING IS CONFIDENTIAL PROPERTY OF SUNMODO AND ITS CONTENTS MAY NOT BE DISCLOSED WITHOUT THE PRIOR WRITTEN CONSENT OF SUNMODO CORP.

MATERIAL SEE NOTES	
Third Angle Projection:	
GENERAL SPECIFICATIONS All Dimensions in inches [millimeters]	
Tolerances	
X.XXX ±0.01 [0.25mm]	Break all sharp edges .010-.020 unless otherwise specified.
X.XX ±0.02 [0.50mm]	
X.X ±0.039 [1.0mm]	
Unless otherwise spec'd	
DRAWN BY KYY	DATE 01/18/2018
CHECKED BY	
APPROVALS	

<b>SunModo Corp.</b>	
14800 NE 65TH STREET, VANCOUVER WA 98682	
TITLE RAIL, HR300 (SUNRAY), EXTRUSION	
B	DRAWING NUMBER A20288
SCALE: NONE	SHEET 1 of 1

REV	DESCRIPTON	BY	DATE
A	0.44 WAS 0.41, 0.44 WAS 0.33	LWF	11/30/2015

NOTES: UNLESS OTHERWISE SPECIFIED

- 1. DIMENSIONS SHOWN ARE INCHES [MILIMETERS].
- 2. MATERIAL: ALUMINUM 6005-T5.  
FINISH: CLEAR ANODIZED 15  $\mu$ m THICK.
- 3. THE UNSPECIFIED DIMENSIONS ARE SPECIFIED BY 2D CAD FILE.

2X 1/4 BOLT SLOT

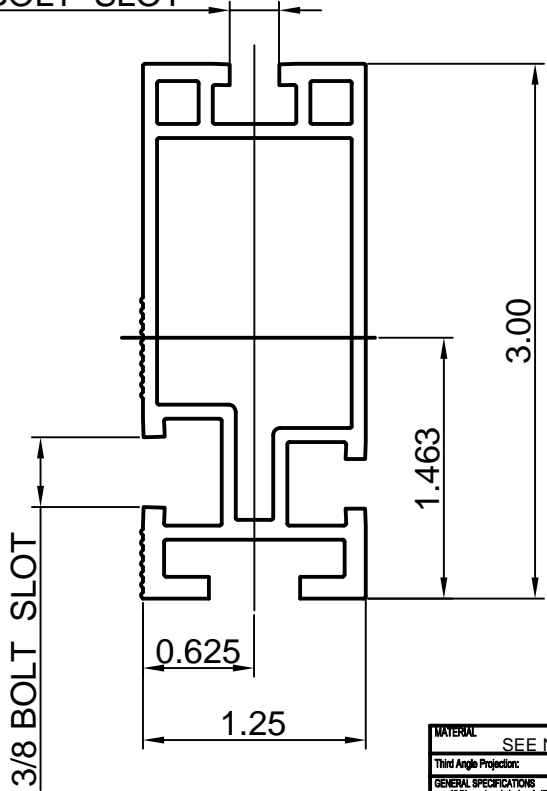

**Section properties:**

Weight: 1.151 lbs/ft  
 Area: 0.980 in<sup>2</sup>  
 Perimeter: 22.104 in  
 Bounding Box: X: -0.625,0.625  
                   Y: -1.463,1.537  
 Centroid:(0.000,0.000)  
 Moments of Inertia(in<sup>4</sup>): Ix=1.047,Iy=0.207  
 Section modulus in bending(in<sup>3</sup>): Wx=0.681,Wy=0.331  
 Radii of Gyration: X: 1.034, Y: 0.460

MATERIAL		SEE NOTES	
Third Angle Projection			
GENERAL SPECIFICATIONS			
All Dimensions in Inches [millimeters]			
Tolerances			
XXX ±0.01 (0.25mm)			
XX ±0.02 (0.50mm)			
X ±0.03 (1.0mm)			
Unless otherwise specified.			
Break all sharp edges 0.10-0.25 unless otherwise specified.			
DRAWN BY		DATE	
ZCJ		02/21/2015	
CHECKED BY		DATE	
APPROVALS		DATE	
		TITLE	
		HELIO HEAVY RAIL	
		DRAWING NUMBER	
		A20145	
		SCALE: NONE	
		SHEET 1 of 1	

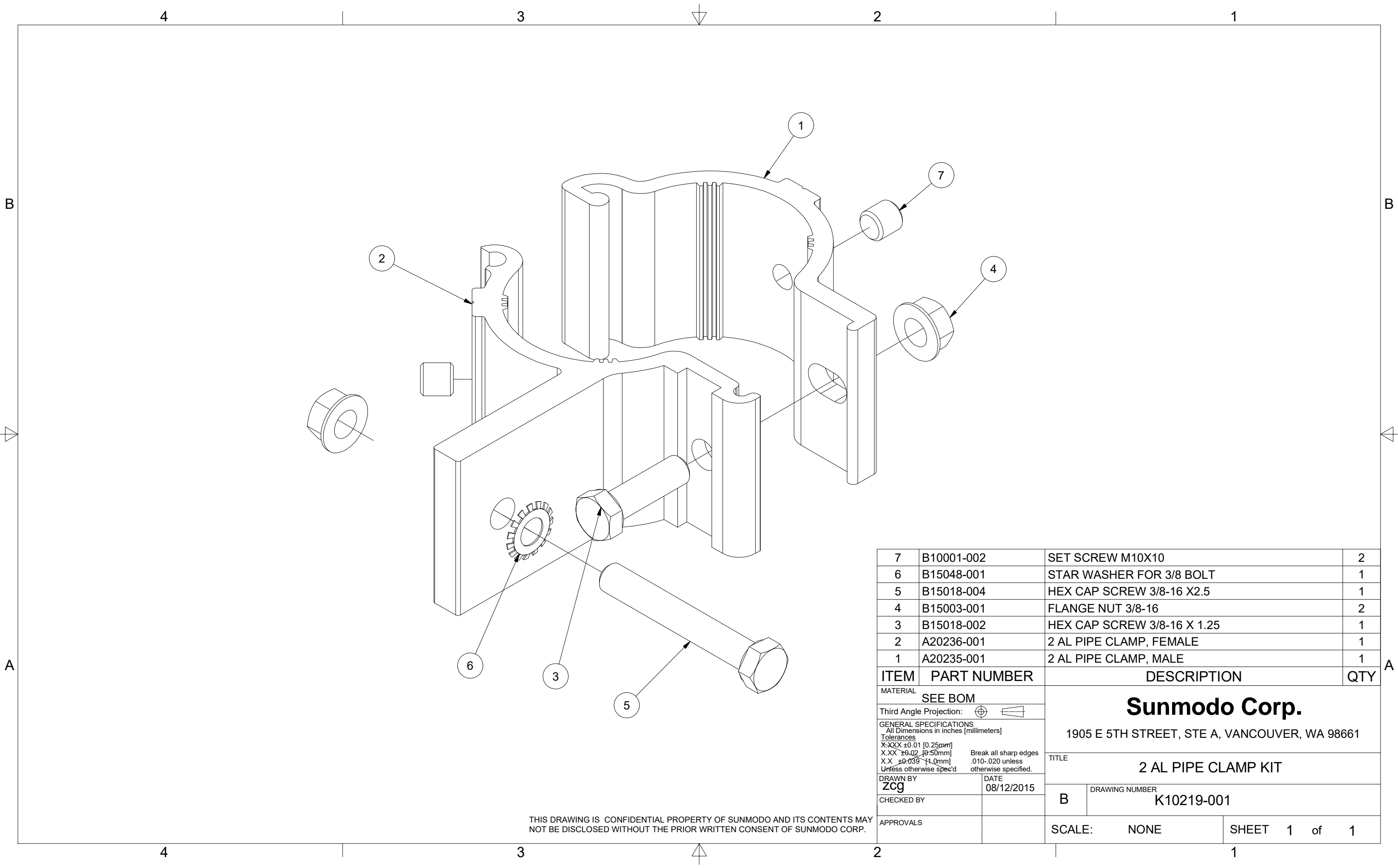

7	B10001-002	SET SCREW M10X10	2
6	B15048-001	STAR WASHER FOR 3/8 BOLT	1
5	B15018-004	HEX CAP SCREW 3/8-16 X2.5	1
4	B15003-001	FLANGE NUT 3/8-16	2
3	B15018-002	HEX CAP SCREW 3/8-16 X 1.25	1
2	A20236-001	2 AL PIPE CLAMP, FEMALE	1
1	A20235-001	2 AL PIPE CLAMP, MALE	1

ITEM	PART NUMBER	DESCRIPTION	QTY
MATERIAL		SEE BOM	
Third Angle Projection:			
GENERAL SPECIFICATIONS		All Dimensions in inches (millimeters)	
Tolerances		X-XXX ±0.01 [0.25mm]	
		X.XX ±0.02 [0.50mm]	
		X.X ±0.039 [1.0mm]	
		Unless otherwise spec'd	
DRAWN BY		DATE	
zcg		08/12/2015	
CHECKED BY			
APPROVALS			
TITLE		2 AL PIPE CLAMP KIT	
DRAWING NUMBER		K10219-001	
SCALE:		NONE	SHEET 1 of 1

THIS DRAWING IS CONFIDENTIAL PROPERTY OF SUNMODO AND ITS CONTENTS MAY NOT BE DISCLOSED WITHOUT THE PRIOR WRITTEN CONSENT OF SUNMODO CORP.

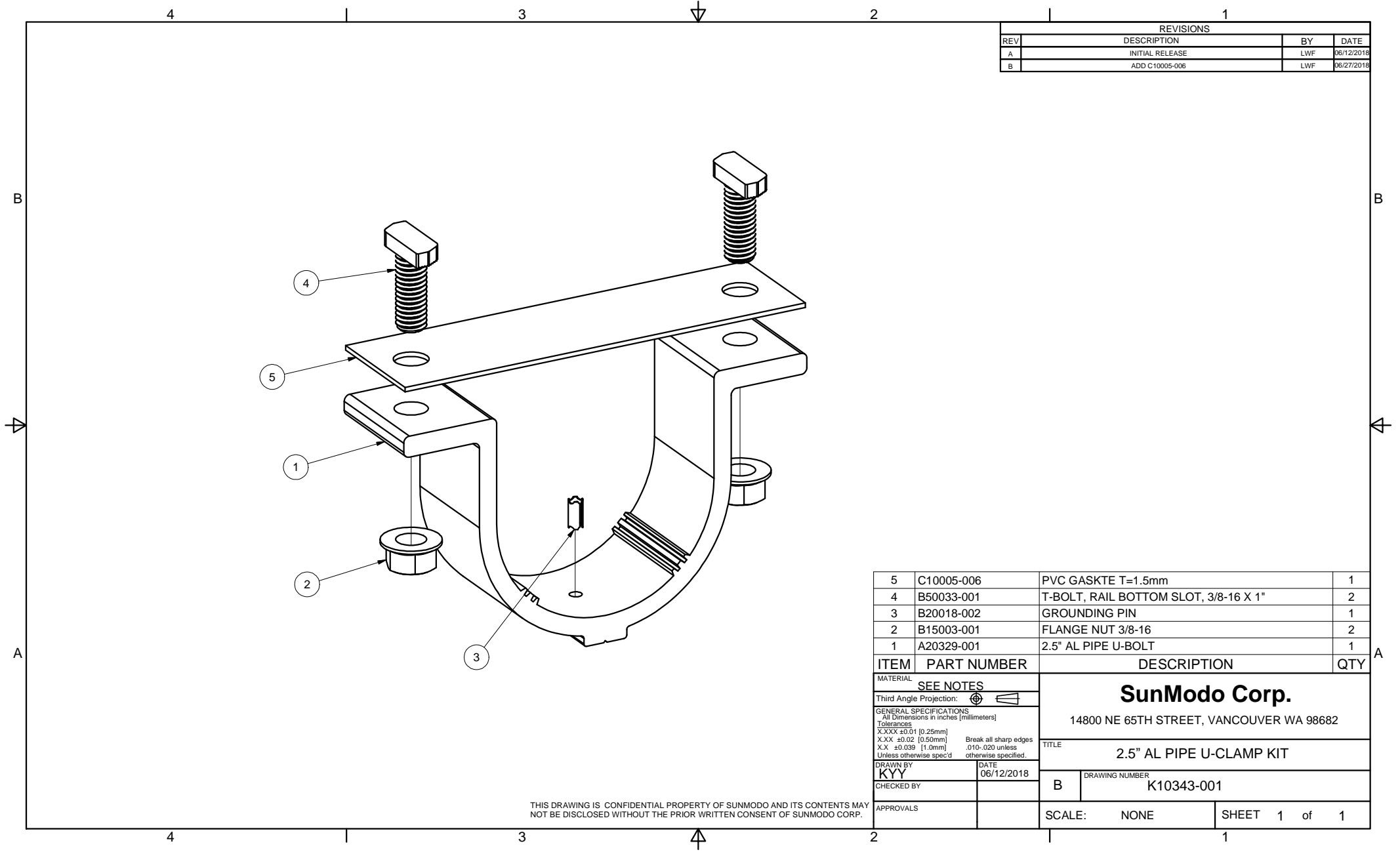

REVISIONS			
REV	DESCRIPTION	BY	DATE
A	INITIAL RELEASE	LWF	06/12/2018
B	ADD C10005-006	LWF	06/27/2018

ITEM	PART NUMBER	DESCRIPTION	QTY
5	C10005-006	PVC GASKTE T=1.5mm	1
4	B50033-001	T-BOLT, RAIL BOTTOM SLOT, 3/8-16 X 1"	2
3	B20018-002	GROUNDING PIN	1
2	B15003-001	FLANGE NUT 3/8-16	2
1	A20329-001	2.5" AL PIPE U-BOLT	1

MATERIAL		<b>SEE NOTES</b>	
Third Angle Projection:			
GENERAL SPECIFICATIONS		<p><b>SunModo Corp.</b> 14800 NE 65TH STREET, VANCOUVER WA 98682</p>	
<small>All Dimensions in inches [millimeters]</small> <small>Tolerances</small> X.XXX ±0.01 [0.25mm] X.XX ±0.02 [0.50mm] X.X ±0.039 [1.0mm] Unless otherwise spec'd			
TITLE		2.5" AL PIPE U-CLAMP KIT	
DRAWN BY	DATE	DRAWING NUMBER	
KYY	06/12/2018	B K10343-001	
CHECKED BY		SCALE: NONE SHEET 1 of 1	
APPROVALS			

THIS DRAWING IS CONFIDENTIAL PROPERTY OF SUNMODO AND ITS CONTENTS MAY NOT BE DISCLOSED WITHOUT THE PRIOR WRITTEN CONSENT OF SUNMODO CORP.

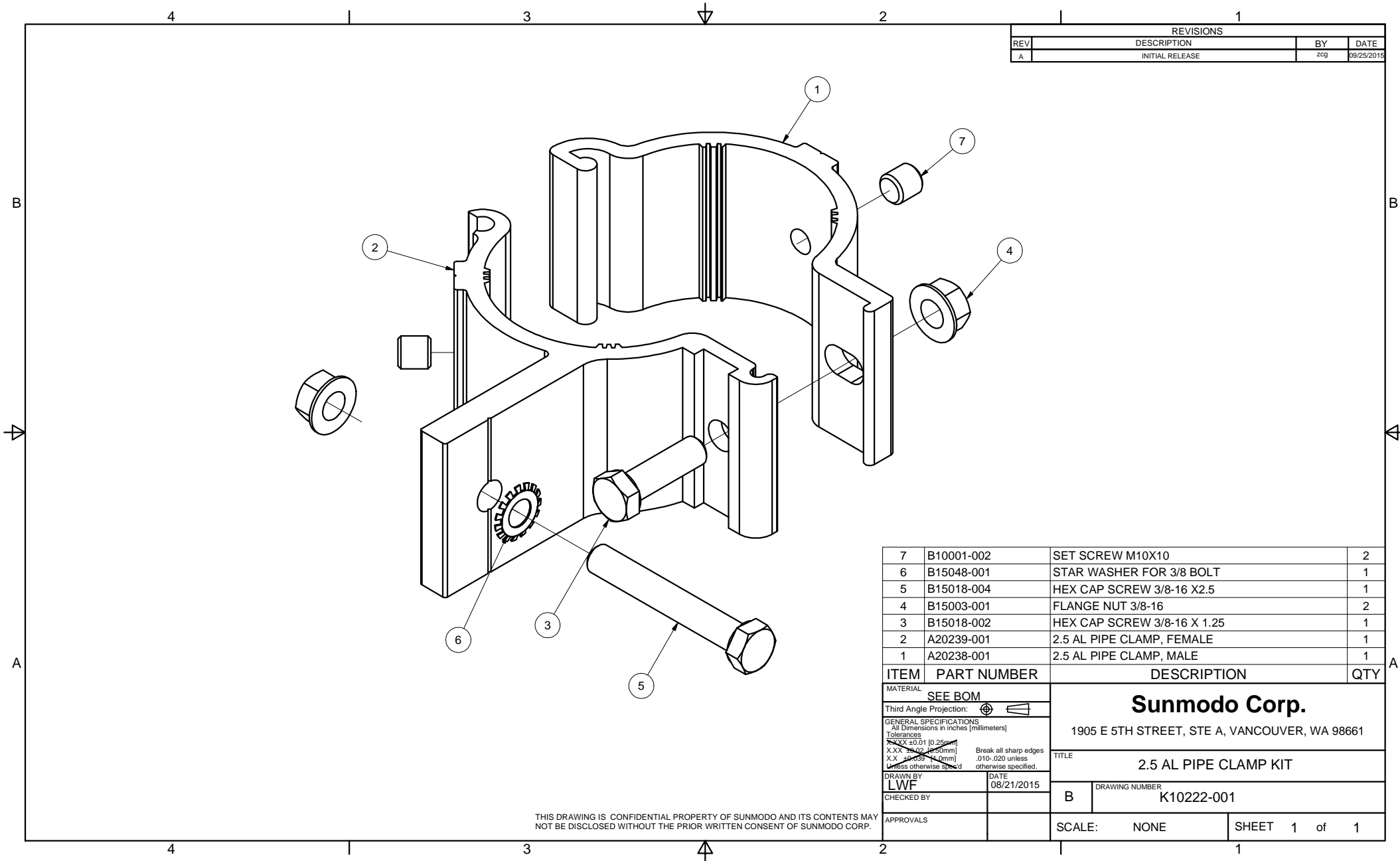

REVISIONS			
REV	DESCRIPTION	BY	DATE
A	INITIAL RELEASE	zcg	09/25/2015

ITEM	PART NUMBER	DESCRIPTION	QTY
7	B10001-002	SET SCREW M10X10	2
6	B15048-001	STAR WASHER FOR 3/8 BOLT	1
5	B15018-004	HEX CAP SCREW 3/8-16 X2.5	1
4	B15003-001	FLANGE NUT 3/8-16	2
3	B15018-002	HEX CAP SCREW 3/8-16 X 1.25	1
2	A20239-001	2.5 AL PIPE CLAMP, FEMALE	1
1	A20238-001	2.5 AL PIPE CLAMP, MALE	1

MATERIAL		<b>SEE BOM</b>	
Third Angle Projection:			
<b>GENERAL SPECIFICATIONS</b> All Dimensions in inches [millimeters] <b>Tolerances</b> X.XX ±0.01 [0.25mm] X.XX ±0.02 [0.50mm] X.X ±0.03 [0.75mm] Unless otherwise specified.			
DRAWN BY		DATE	
LWF		08/21/2015	
CHECKED BY		B	
APPROVALS		SCALE: NONE	
		SHEET 1 of 1	

**Sunmodo Corp.**  
 1905 E 5TH STREET, STE A, VANCOUVER, WA 98661

TITLE  
**2.5 AL PIPE CLAMP KIT**

DRAWING NUMBER  
**K10222-001**

THIS DRAWING IS CONFIDENTIAL PROPERTY OF SUNMODO AND ITS CONTENTS MAY NOT BE DISCLOSED WITHOUT THE PRIOR WRITTEN CONSENT OF SUNMODO CORP.

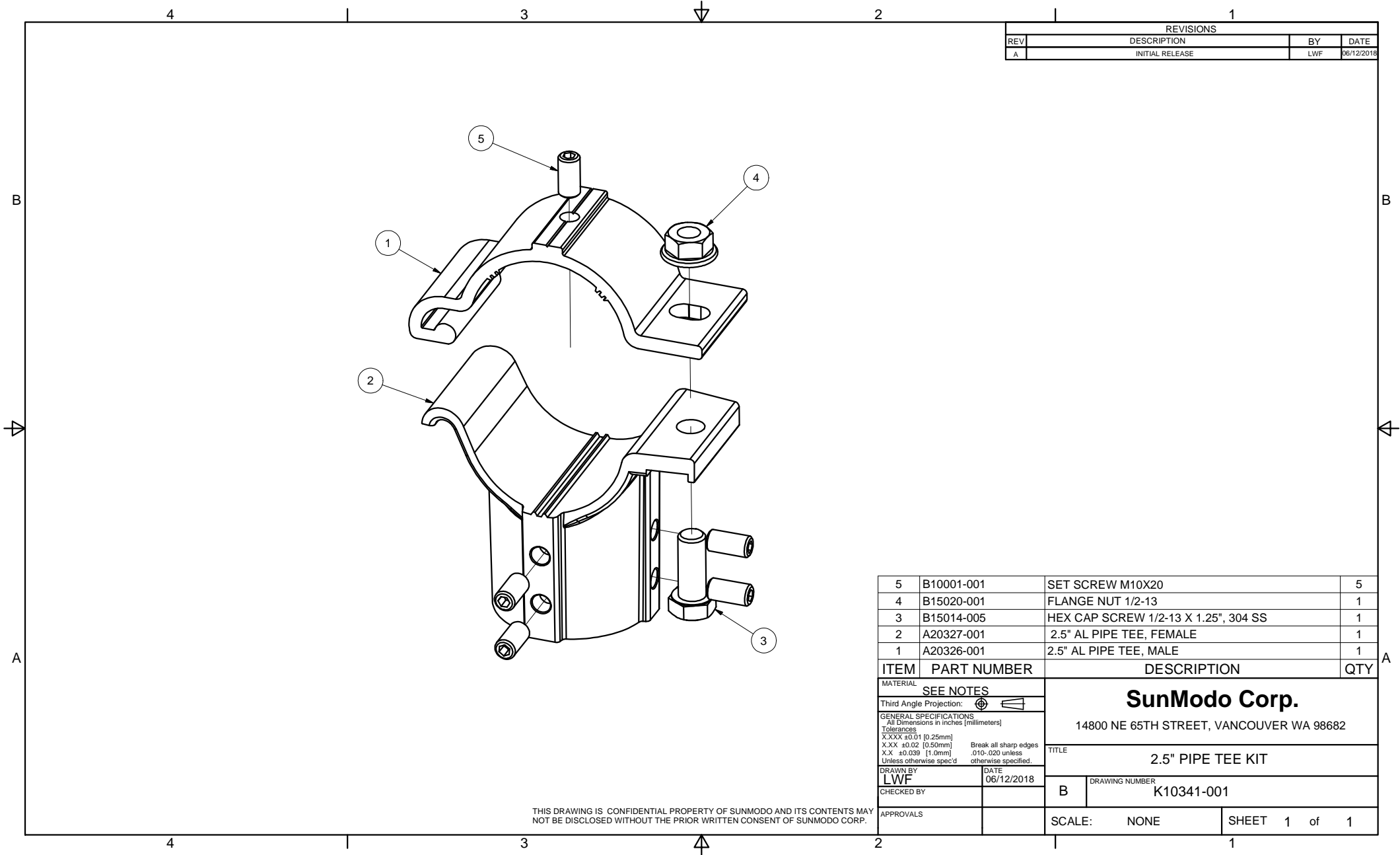

REVISIONS			
REV	DESCRIPTION	BY	DATE
A	INITIAL RELEASE	LWF	06/12/2018

ITEM	PART NUMBER	DESCRIPTION	QTY
5	B10001-001	SET SCREW M10X20	5
4	B15020-001	FLANGE NUT 1/2-13	1
3	B15014-005	HEX CAP SCREW 1/2-13 X 1.25", 304 SS	1
2	A20327-001	2.5" AL PIPE TEE, FEMALE	1
1	A20326-001	2.5" AL PIPE TEE, MALE	1

MATERIAL		SEE NOTES	
Third Angle Projection:			
GENERAL SPECIFICATIONS		<b>SunModo Corp.</b> 14800 NE 65TH STREET, VANCOUVER WA 98682	
Tolerances		TITLE	
X.XXX ±0.01 [0.25mm] X.XX ±0.02 [0.50mm] X.X ±0.039 [1.0mm] Unless otherwise spec'd		2.5" PIPE TEE KIT	
DRAWN BY		DATE	
LWF		06/12/2018	
CHECKED BY		DRAWING NUMBER	
		B K10341-001	
APPROVALS		SCALE: NONE SHEET 1 of 1	

THIS DRAWING IS CONFIDENTIAL PROPERTY OF SUNMODO AND ITS CONTENTS MAY NOT BE DISCLOSED WITHOUT THE PRIOR WRITTEN CONSENT OF SUNMODO CORP.

REVISIONS			
REV	DESCRIPTION	BY	DATE
A	INITIAL RELEASE	LWF	06/12/2018

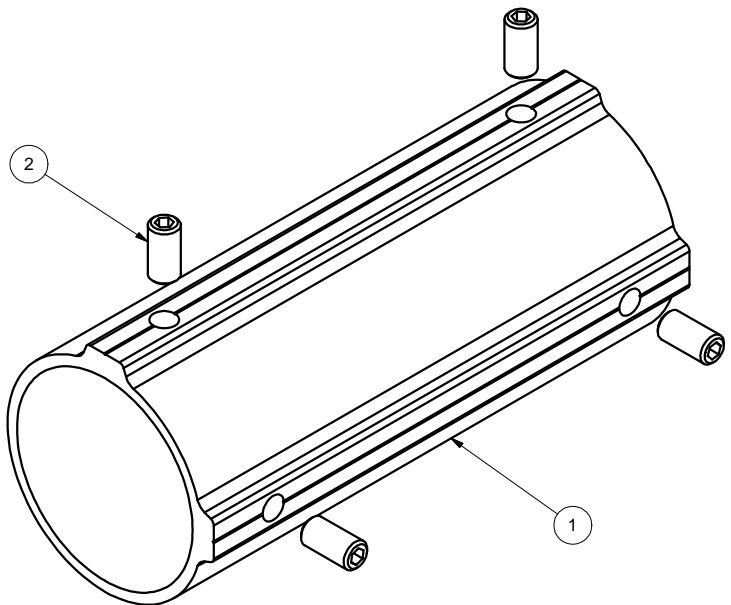

2	B10001-001	SET SCREW M10X20	4
1	A20328-001	2.5" PIPE SPLICE	1
ITEM	PART NUMBER	DESCRIPTION	QTY
MATERIAL		SEE NOTES	
Third Angle Projection:			
GENERAL SPECIFICATIONS		<b>SunModo Corp.</b> 14800 NE 65TH STREET, VANCOUVER WA 98682	
All Dimensions in inches [millimeters] Tolerances X.XXX ±0.01 [0.25mm] X.XX ±0.02 [0.50mm] X.X ±0.039 [1.0mm] Unless otherwise spec'd		TITLE <b>2.5" PIPE SPLICE KIT</b>	
DRAWN BY	DATE	DRAWING NUMBER	
LWF	06/12/2018	B K10342-001	
CHECKED BY			
APPROVALS		SCALE: NONE	SHEET 1 of 1

THIS DRAWING IS CONFIDENTIAL PROPERTY OF SUNMODO AND ITS CONTENTS MAY NOT BE DISCLOSED WITHOUT THE PRIOR WRITTEN CONSENT OF SUNMODO CORP.

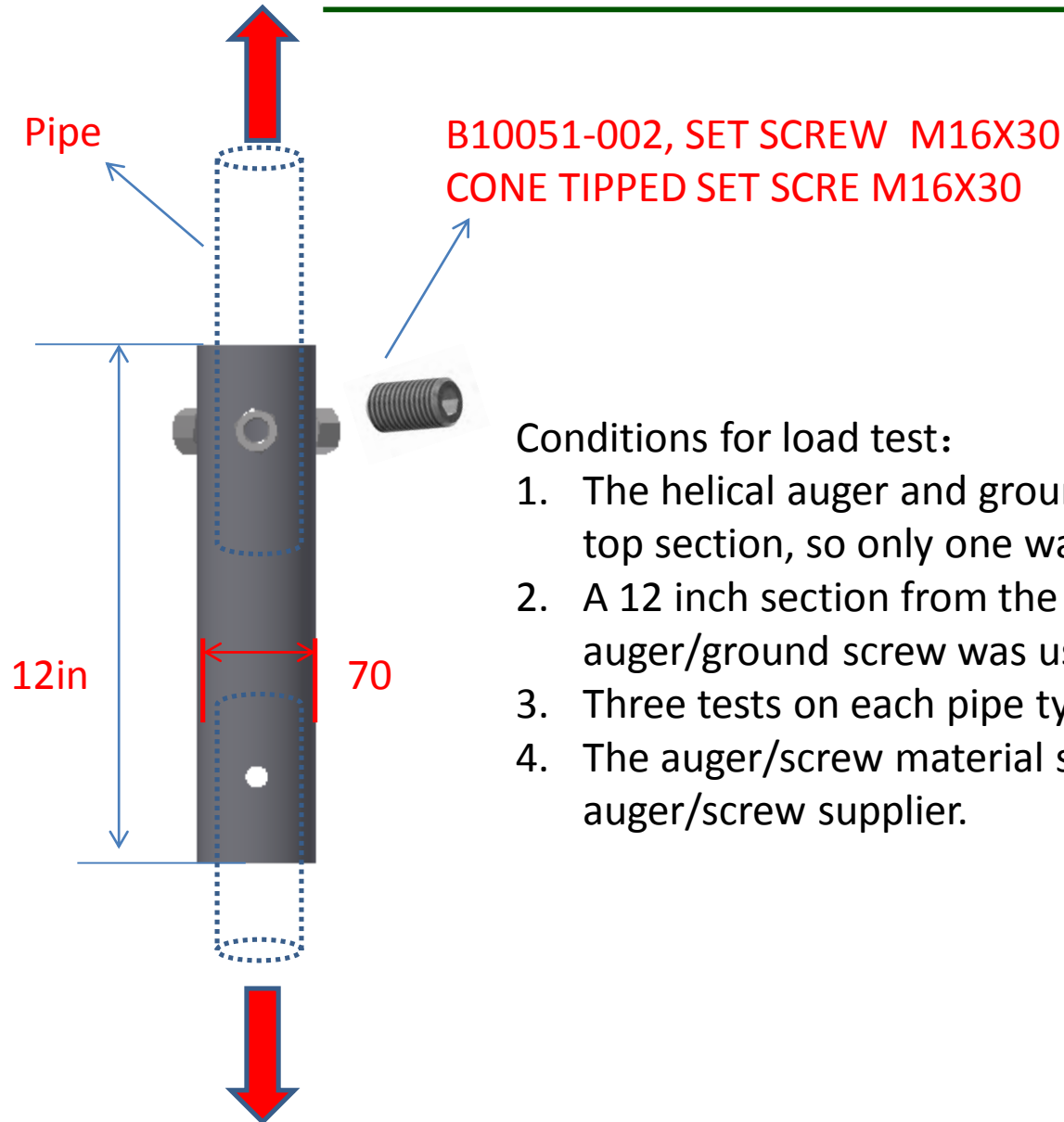

### Conditions for load test:

1. The helical auger and ground screw use the same top section, so only one was used for testing
2. A 12 inch section from the top of the auger/ground screw was used
3. Three tests on each pipe type was used
4. The auger/screw material supplied by the auger/screw supplier.