

NOTES: UNLESS OTHERWISE SPECIFIED

1. THIS DRAWING IS NOT FOR CONSTRUCTION UNTIL ENGINEERING HAS REVIEWED AND STAMPED THIS DOCUMENT.
2. DIMENSIONS SHOWN ARE INCHES[MM].
3. 304 STAINLESS STEEL HARDWARE. ALL OTHER PARTS ARE 6005-T5 AL WITH ANODIZING. PIPE MATERIAL FOR THE TYPE OF PROJECT: GROUND MOUNT = STEEL SB = ALUMINUM
4. 2PXN-40DEG-GSM-Alberta.
5. 1 OF 1 ARRAY TYPE.
6. 1 ARRAY TOTAL.
7. THE MAXIMUM PERMISSIBLE LENGTH OF ANY STRUCTURE SHALL BE 200 FT. FOR SYSTEMS USING A SHARED RAIL CONFIGURATION, A THERMAL BREAK IS REQUIRED IN THE RAIL EVERY 40 FT. PER THE DRAWING DETAILS.
8. APPROVED RAIL PROFILES
A20144-HR250
A20288-HR300
A20145-HR350

DESIGN CRITERIA:
Alberta Building Code 2014
Minimum Design Loads for Buildings and Other Structures (ASCE 7-10)
Ground snow load: 39.7 psf (1.9 kPa)
Wind speed for risk category I structures: 105 mph
Wind Exposure: C

For part drawings and ground screw and helical pier demands see letter dated: February 12, 2019

The HR250 rails may be replaced with either HR300 or HR350 rails. The part drawings for these rails can be found in the structural letter dated 02/12/2019

VECTOR PROJECT #: U2716-071-181
ALBERTA FIRM LICENSE: 14521

STRUCTURAL
ONLY

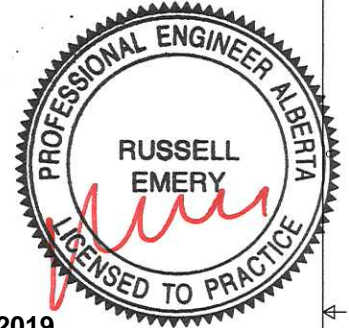

02/15/2019

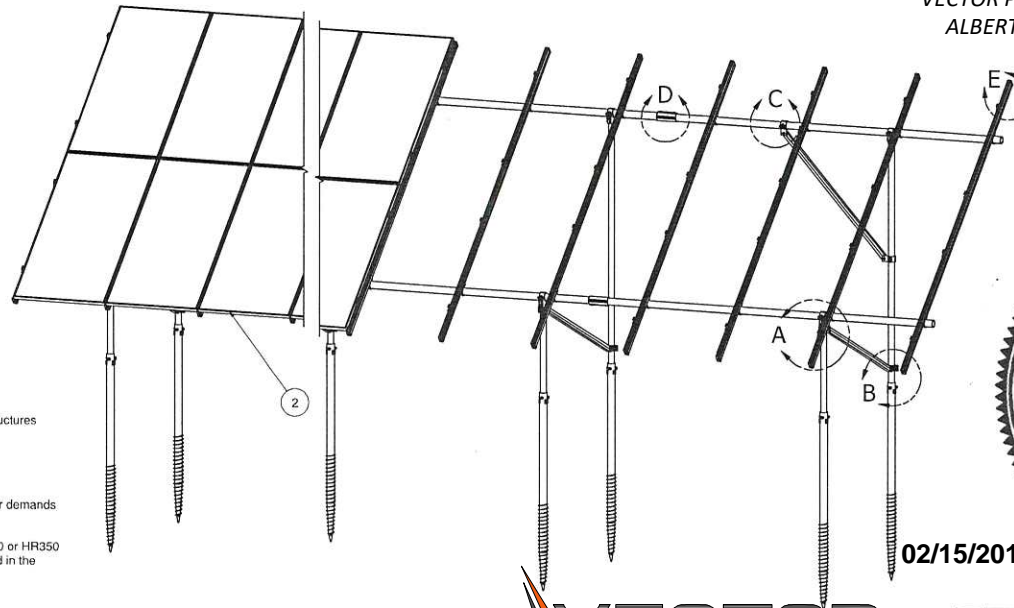

DETAIL E

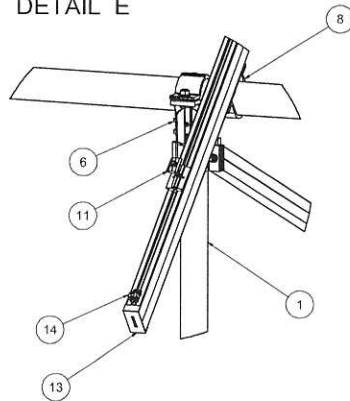

DETAIL A

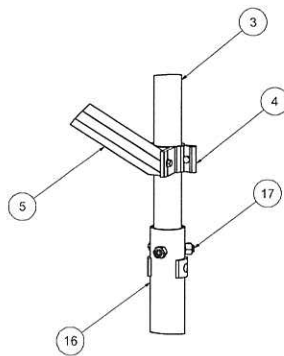

DETAIL B

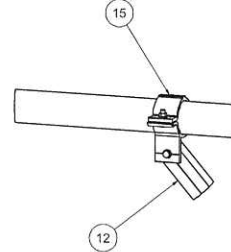

DETAIL C

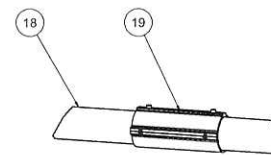

DETAIL D



651 W. GALENA PARK BLVD. STE. 101 DRAPER, UTAH 84020
PHONE (801) 990-1775 WWW.VECTORSE.COM

ITEM	PART NUMBER	DESCRIPTION	QTY
19	K10342-001	2.5" PIPE SPLICE KIT	
18	A21023-147	2.5" STEEL PIPE, L=147	
17	B10055-001	CONE-POINT SET SCREW M16X25	
16	A21147-080	ANCHOR, SCREW AUGER, L=80	
15	K10222-001	2.5 PIPE CLAMP KIT	
14	K10179-001	SELF-GROUNDING LUG KIT	
13	A20284-001	END CAP HR250 GRAY	
12	A20164-066	1.5X2 AL TUBE BRACE, L=66	
11	K10182-001	LANDSCAPE GROUNDING MID CLAMP KIT	
10	K10224-140	END CLAMP KIT WITH COLLAR	
9	K10176-001	LANDSCAPE GROUNDING ADAPTOR	
8	K10343-001	2.5" AL PIPE U-CLAMP KIT	
7	A20144-154	RAIL, HR250(HELIO STANDARD), L=154	
6	K10341-001	2.5" PIPE TEE KIT	
5	A20164-076	1.5X2 AL TUBE BRACE, L=76	
4	K10219-001	2" PIPE CLAMP KIT	
3	A21022-112	2" STEEL PIPE, L=112	
2		PANEL: 1956X992X40mm	
1	AZ1022-049	2" STEEL PIPE, L=49	
ITEM	PART NUMBER	DESCRIPTION	QTY
REVISION: SEE BOM			
14800 NE 65TH STREET, VANCOUVER WA 98662			
ALBERTA / BRITISH COLUMBIA / ONTARIO - 2P			
SCALE: 1/23 SHEET 1 of 3			

THIS DRAWING IS CONSIDERED THE PROPERTY OF VECTOR ENGINEERS. IT IS TO BE USED ONLY FOR THE PROJECT AND NOT BE REPRODUCED OR TRANSMITTED IN ANY FORM OR BY ANY MEANS WITHOUT THE WRITTEN PERMISSION OF VECTOR ENGINEERS.

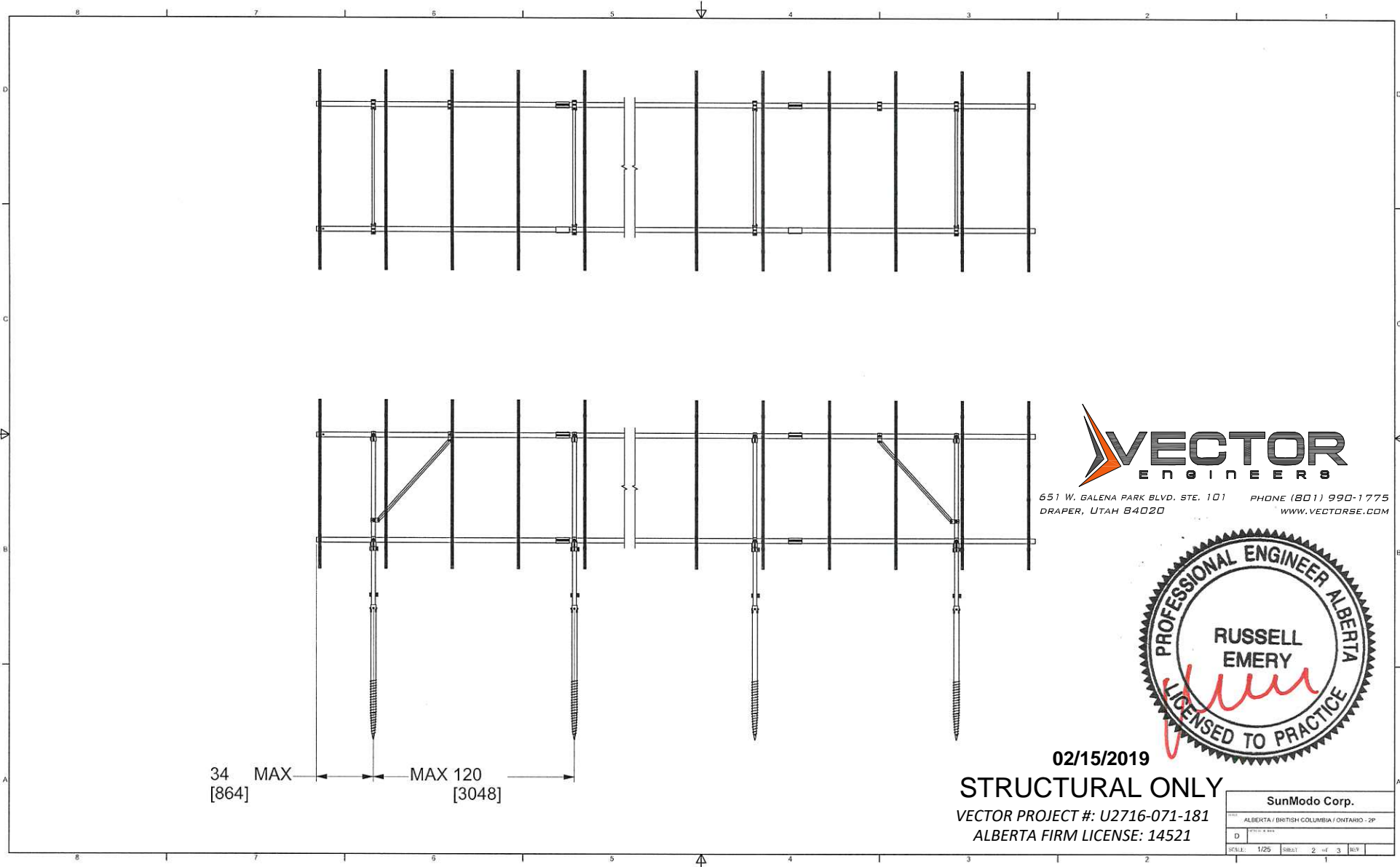

651 W. GALENA PARK BLVD. STE. 101 PHONE (801) 990-1775
 DRAPER, UTAH 84020 WWW.VECTORSE.COM

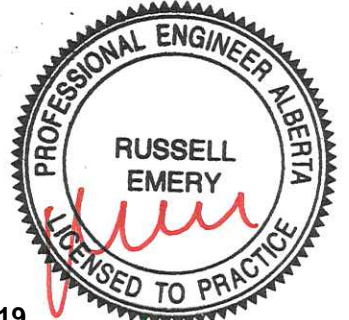

02/15/2019

STRUCTURAL ONLY

VECTOR PROJECT #: U2716-071-181
 ALBERTA FIRM LICENSE: 14521

SunModo Corp.			
ALBERTA / BRITISH COLUMBIA / ONTARIO - 2P			
D			
SCALE: 1/25	REVISION: 2	REV: 3	REV:

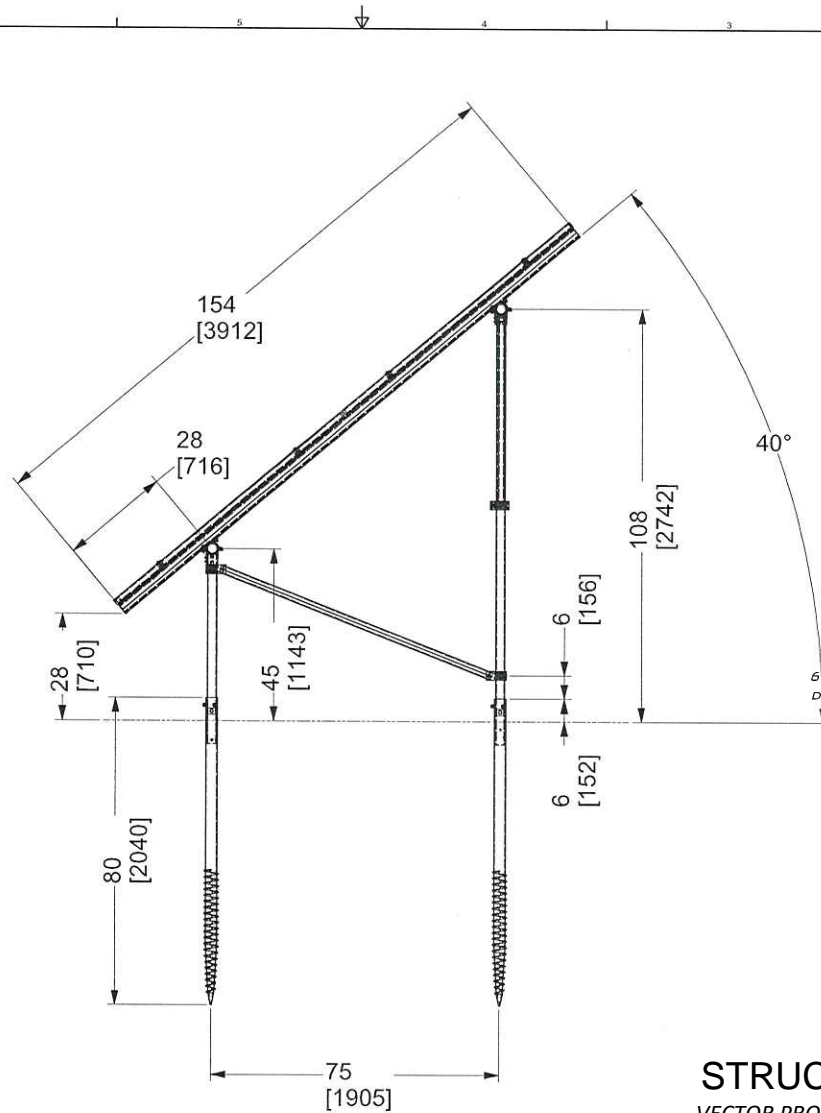

651 W. GALENA PARK BLVD. STE. 101 PHONE (801) 990-1775
 DRAPER, UTAH 84020 WWW.VECTORSE.COM

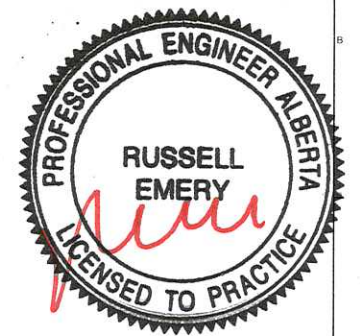

02/15/2019
STRUCTURAL ONLY
 VECTOR PROJECT #: U2716-071-181
 ALBERTA FIRM LICENSE: 14521

SunModo Corp.	
ALBERTA / BRITISH COLUMBIA / ONTARIO - 2P	
D	
SCALE: 1/15	SHEET 3 of 3 REV